

# FEAL

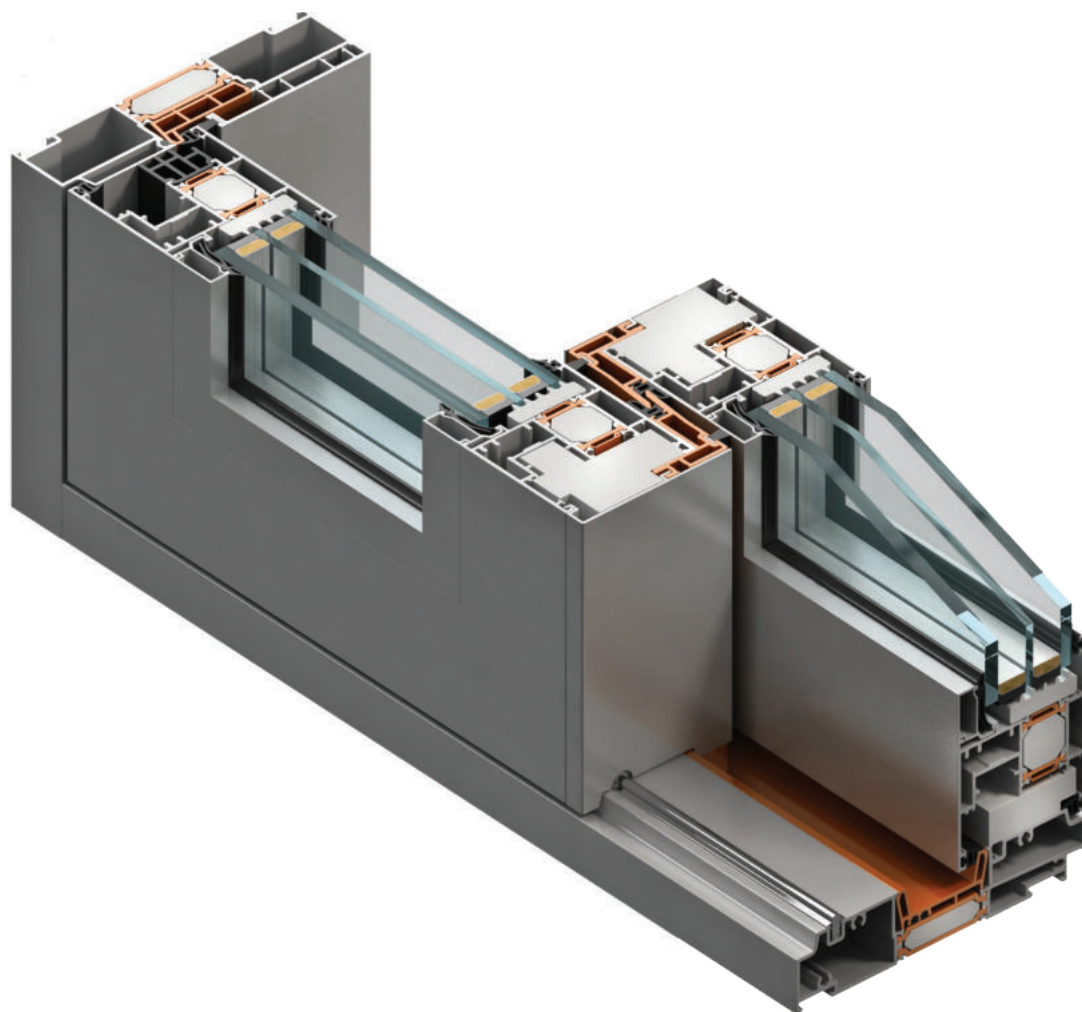

## TERMO 150

PODIZNO-KLIZNA VRATA  
*LIFT & SLIDE DOORS*

Knjiga B / *Book B*



## SADRŽAJ - CONTENT

06	VEZNI ELEMENTI	406.06.000
06	CONNECTION ELEMENTS	406.06.000
07	PVC ELEMENTI	406.07.000
07	PVC ELEMENTS	406.07.000
08	MEHANIZMI	406.08.000
08	MECHANISMS	406.08.000
09	BRTVILA	406.09.000
09	GASKETS	406.09.000
10	DODACI	406.10.000
10	ACCESSORIES	406.10.000
11	OBRADA I MONTAŽA TERMO 150	406.11.000
11	PROCESSING AND MONTAGE TERMO 150	406.11.000
11	OBRADA I MONTAŽA TERMO 150 plus	406.11.100
11	PROCESSING AND MONTAGE TERMO 150 plus	406.11.100
12	REZNE LISTE	406.12.000
12	CUTTING LISTS	406.12.000



# Vezni elementi

## Connection elements

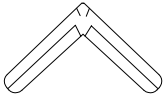
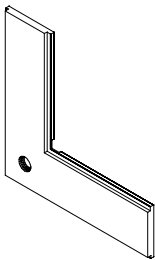
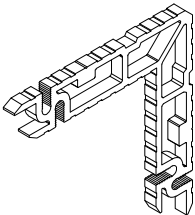
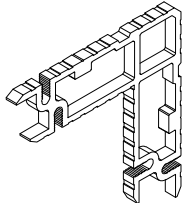
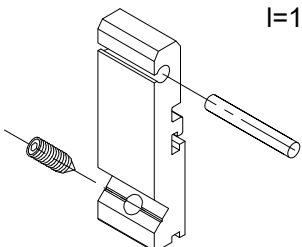
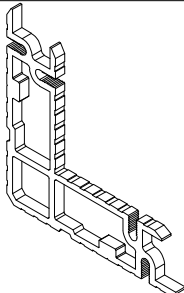

Oznaka Code	Izgled-presjek View- cross section	Opis Description	Materijal Material	Napomena Remark
730.002		<ul style="list-style-type: none"> <li>- Kutna spojnica za komoru 4.8x2</li> <li>- (Stara oznaka: G112/A)</li> <li>- Corner bracket for chamber 4.8x2</li> <li>- (Former code: G112/A)</li> </ul>	Inox	
730.017		<ul style="list-style-type: none"> <li>- Pomoćni kutnik 18.7</li> <li>- Auxiliary corners 18.7</li> </ul>	Zamak	
710.188	 l=7.5 mm	<ul style="list-style-type: none"> <li>- Kutna spojnica 24.6, L=7.5</li> <li>- Koristi se za profil krila FT-1020</li> <li>- Corner bracket 24.6, L=7.5</li> <li>- Used for sash profile FT-1020</li> </ul>	Al.	
710.189	 l=7.5 mm	<ul style="list-style-type: none"> <li>- Kutna spojnica 34.6, L=7.5</li> <li>- Koristi se za profil krila FT-1022</li> <li>- Corner bracket 34.6, L=7.5</li> <li>- Used for sash profile FT-1022</li> </ul>	Al.	
710.212	 l=12.8mm	<ul style="list-style-type: none"> <li>-Dodatni veznik L=12.8 (Termo 150 Plus)</li> <li>-Extra connector L=12.8 (Termo 150 Plus)</li> </ul>	Al	
710.401		<ul style="list-style-type: none"> <li>- Kutna spojnica 34.6, L=6.6</li> <li>- Corner bracket for chamber 7.1x35.1</li> </ul>	Al	

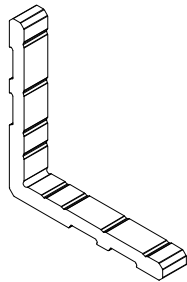
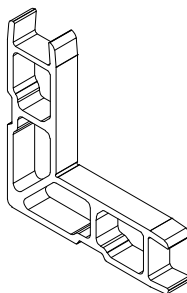
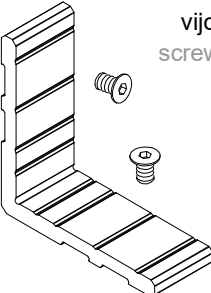
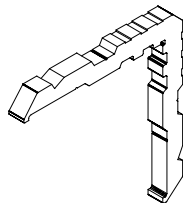
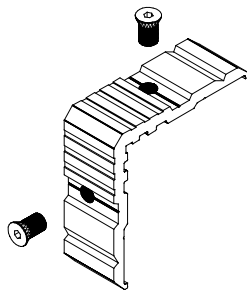
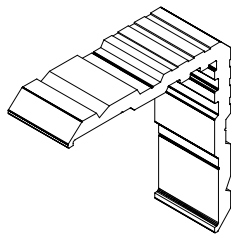
Oznaka Code	Izgled-presjek View-cross section	Opis Description	Materijal Material	Napomena Remark
710.402		- Kutna spojnica 6, L=9.4 - Corner bracket 6, L=9.4	Al	
710.403		- Kutna spojnica 21.1, L=9.4 - Corner bracket 21.1, L=9.4	Al	
710.404	 vijci 431.265 screw 431.265 M8x10	- Kutna spojnica 6, L=23.4 - Corner bracket 6, L=23.4	Al	
710.489	 l=7.5 mm	- Kutna spojnica 10, L=7.5 - Koristi se za profil krila FT-1021 - Corner bracket 10, L=7.5 - Used for sash profile FT-1021	Al.	
710.490	 l=29.4 mm M8x10	- Kutna spojnica 8, L=29.4 (s vijcima) - Koristi se za profile krila FT-1020, FT-1021 i FT-1022 - Corner bracket 8, L=29.4 (s vijcima) - Used for sash profile FT-1020, FT-1021 i FT-1022	Al.	
710.497	 l=29.4 mm	- Kutna spojnica 8, L=29.4 - Koristi se za profile krila FT-1020, FT-1021 i FT-1022 - Corner bracket 8, L=29.4 - Used for sash profile FT-1020, FT-1021 i FT-1022	Al.	

Oznaka Code	Izgled-presjek View-cross section	Opis Description	Materijal Material	Napomena Remark
710.523		- Kutna spojnica 29.4, L=11.6 (s vijcima)  M8x13	Al	
710.524		- Kutna spojnica 12.5, L=15.7 (s vijcima)  M8x10	Al	
710.538	 l=13.8mm M8x10 M6x10	- Veznik prečke (L=13.8mm) - Radi se iz profila F-45052/A (Termo 150 Plus) -Connector of the mullion(L=13.8mm) -Made out of profile F-45052/A (Termo 150 Plus)	Al	
710.543	 l=14.8mm 3.5x13 DIN 7982	- Dodatni veznik 14.8 (s vijcima) (Termo 150 Plus) - Extra connector14.8(with screws) (Termo 150 Plus)	Al	
731.010		- Kutna spojnica za komoru 19.1x1.6 - Stara oznaka 2019/500 - Corner bracket for chamber 19.1x1.6 - Former code 2019/500	Zamak	

Oznaka Code	Izgled-presjek View-cross section	Opis Description	Materijal Material	Napomena Remark
710.609	 <p>M 6x16 DIN 913</p>	<ul style="list-style-type: none"> <li>-Kutna spojnica 45, L=14 (s vijcima)</li> <li>-Koristi se za profil FT-1101 spoj pod 90°</li> <li>-(Termo 150 plus)</li> <li>-Corner bracket 45, L=14 (with screws)</li> <li>-Used for profiles FT-1101 join under 90°</li> <li>-(Termo 150 plus)</li> </ul>	Al	
710.610	 <p>I=14mm</p> <p>M8x13</p>	<ul style="list-style-type: none"> <li>- Kutna spojnica 24.6, L=14 (s vijcima)</li> <li>- Koristi se za profil FT-1101 spoj pod 90°</li> <li>-(Termo 150 plus)</li> <li>- Corner bracket 24.6, L=14 (with screws)</li> <li>- Used for profiles FT-1101 join under 90°</li> <li>-(Termo 150 plus)</li> </ul>	Al	
710.611	 <p>I=16mm</p> <p>M8x13</p>	<ul style="list-style-type: none"> <li>- Kutna spojnica 16, L=16 (s vijcima)</li> <li>- Koristi se za profil FT-1101 spoj rama pod 90°</li> <li>-(Termo 150 plus)</li> <li>- Corner bracket 16, L=16 (with screws)</li> <li>- Used for profiles FT-1101 join under 90°</li> <li>-(Termo 150 plus)</li> </ul>	Al	
710.612	 <p>I=15mm</p>	<ul style="list-style-type: none"> <li>- Kutna spojnica 2, L=15</li> <li>- Koristi se za profil FT-1101 spoj rama pod 90°</li> <li>-(Termo 150 plus)</li> <li>- Corner bracket 2, L=15 (with screws)</li> <li>- Used for profiles FT-1101 join under 90°</li> <li>-(Termo 150 plus)</li> </ul>	Al	
710.431	 <p>M6x16</p>	<ul style="list-style-type: none"> <li>- Kutna spojnica 11.5 L=34.6 (s vijcima)</li> <li>- Koristi se za profil FT-1101 spoj rama pod 90°</li> <li>-(Termo 150 plus)</li> <li>- Corner bracket 11.5, L=34.6 (with screws)</li> <li>- Used for profiles FT-1101 join under 90°</li> <li>-(Termo 150 plus)</li> </ul>	Al	

**PVC elementi**  
PVC elements

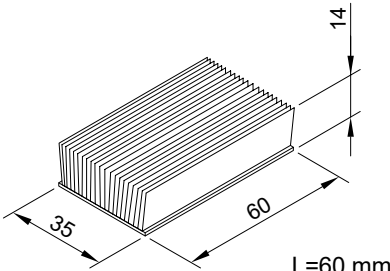
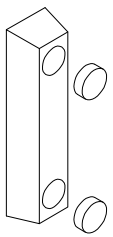
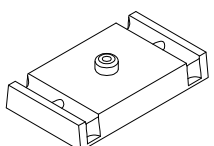
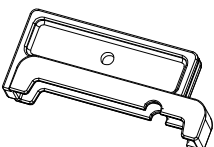
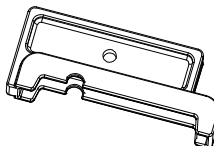
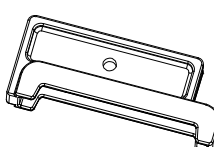

Oznaka Code	Izgled-presjek View - cross section	Opis Description	Materijal Material	Napomena Remark
340.082		<ul style="list-style-type: none"> <li>- Četkasta brtva 35x14mm(samoljepiva)</li> <li>- Duljina rezanja L=60 mm</li> <li>- Brush gasket 35x14- self-adhesive</li> <li>- Cut lenght L=60 mm</li> </ul>		
345.010		<ul style="list-style-type: none"> <li>- Ublaživač udara krila</li> <li>- Stara oznaka: OK-120-03/04</li> <li>- Sash bumper</li> <li>- Former code:OK-120-03/04</li> </ul>	Tvrda guma Hard rubber	
360.003		<ul style="list-style-type: none"> <li>- Umetak u ramu (donji), na spoju krila</li> <li>- Za lijeva i desna vrata</li> <li>- Stara oznaka K109</li> <li>- Insert in frame, on sash joint - lower</li> <li>- For right and left door</li> <li>- Former code K109</li> </ul>	Guma Rubber	
360.004		<ul style="list-style-type: none"> <li>- Umetak za profil F-1433 - donji (za vanjsko krilo)</li> <li>- Za lijeva i desna vrata (oba krila otvarajuća)</li> <li>- Stara oznaka K110</li> <li>- Insert for profile F-1433 - lower (for exterior sash)</li> <li>- For left and right door (both sash fitting)</li> <li>- Former code K110</li> </ul>	Guma Guma	
360.005		<ul style="list-style-type: none"> <li>- Umetak za profil F-1433 - donji (otvarajuće krilo)</li> <li>- Za lijeva i desna vrata s fiksnim dijelom</li> <li>- Stara oznaka K111</li> <li>- Insert for profile F-1433 - lower (opening sash)</li> <li>- For left and right door with fixed part</li> <li>- Former code K111</li> </ul>	Guma Rubber	
360.006		<ul style="list-style-type: none"> <li>- Umetak za profil F-1433-gornji i donji (fiksno krilo)</li> <li>- Za desna i lijeva vrata</li> <li>- Stara oznaka K112</li> <li>- Insert for profile F-1433 - upper and lower (fixed sash)</li> <li>- For right and left door</li> <li>- Former code K112</li> </ul>	Guma Rubber	

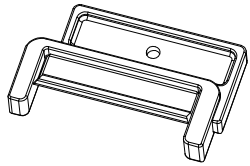
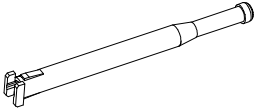
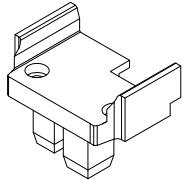
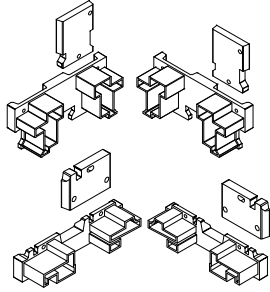
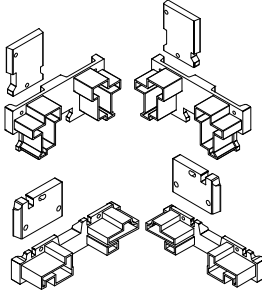
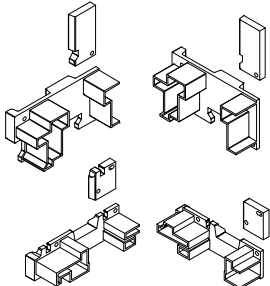
Oznaka Code	Izgled-presjek View - cross section	Opis Description	Materijal Material	Napomena Remark
360.007		<ul style="list-style-type: none"> <li>- Umetak za profil F-1433 - gornji (otvarajuće krilo)</li> <li>- Za desna i lijeva vrata</li> <li>- Stara oznaka K113</li> <li>- Insert for profile F-1433 - upper (opening sash)</li> <li>- For right and left door</li> <li>- Former code K113</li> </ul>	Guma Rubber	
360.009		<ul style="list-style-type: none"> <li>- Sustav odvodnje kapljevina Monodrain (Monodrain art.:302006)</li> <li>- Drainage system Monodrain</li> <li>- Manufacturer code:302006</li> </ul>		
363.030		<ul style="list-style-type: none"> <li>- Umetak za profil FT-1030F</li> <li>- Insert for profile FT-1030F</li> </ul>	Tvrda guma Hard rubber	
363.043		<ul style="list-style-type: none"> <li>Set umetaka za lijeva dvokrilna vrata</li> <li>Set of inserts for left double sash door</li> </ul>	Tvrda guma Hard rubber	
363.044		<ul style="list-style-type: none"> <li>Set umetaka za desna dvokrilna vrata</li> <li>Set of inserts for right double sash door</li> </ul>	Tvrda guma Hard rubber	
363.045		<ul style="list-style-type: none"> <li>Set umetaka za lijeva trokrilna vrata</li> <li>Set of inserts for left triple sash door</li> </ul>	Tvrda guma Hard rubber	

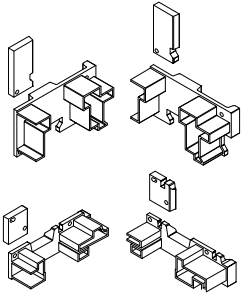
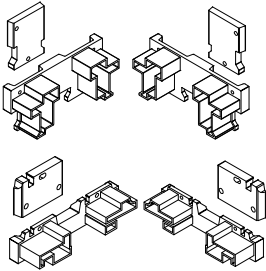
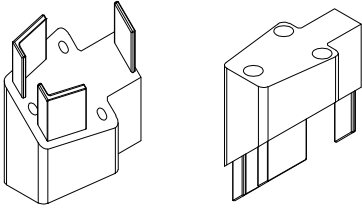
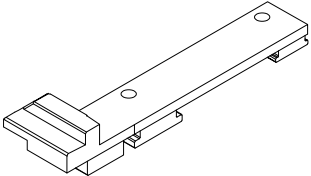
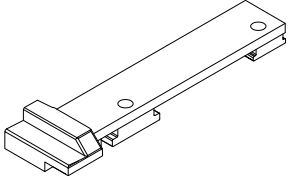
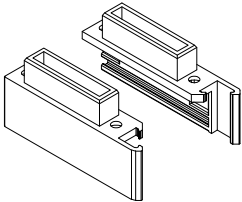
Oznaka Code	Izgled-presjek View - cross section	Opis Description	Materijal Material	Napomena Remark
363.046		Set umetaka za desna trokrilna vrata Set of inserts for right triple sash door	Tvrda guma Hard rubber	
363.047		Set umetaka za četverokrilna vrata Set of inserts for four sash door	Tvrda guma Hard rubber	
363.052		- Čep na krilu FT-1121 na sredini - Cap on middle sash FT-1121	Tvrda guma Hard rubber	
363.053		- Čep na prečki FT-1130F u pragu (lijevi) - Cap on mullion FT-1130F in treshold (left)	Tvrda guma Hard rubber	
363.054		- Čep na prečki FT-1130F u pragu (desni) - Cap on mullion FT-1130F in treshold (right)	Tvrda guma Hard rubber	
363.055		- Čep na spoju dva krila pod 90° - Cap for two sash joint under 90°	Tvrda guma Hard rubber	

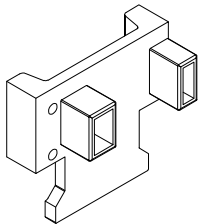
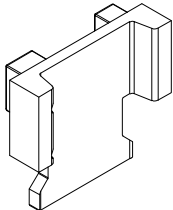
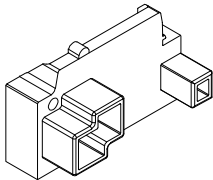
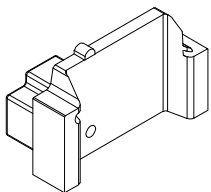
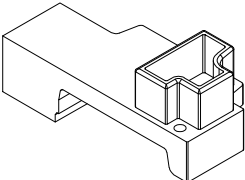
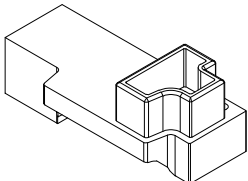
Oznaka Code	Izgled-presjek View - cross section	Opis Description	Materijal Material	Napomena Remark
363.056		- Čep za gornji spoj rama (lijevi) - Cap for upper frame joint (left)	Tvrda guma Hard rubber	
363.057		- Čep za gornji spoj rama (desni) - Cap for upper frame joint (right)	Tvrda guma Hard rubber	
363.058		- Čep za donji spoj rama (lijevi) - Cap for lower frame joint (left)	Tvrda guma Hard rubber	
363.059		- Čep za donji spoj rama (desni) - Cap for lower frame joint (right)	Tvrda guma Hard rubber	
363.060		- Čep za donji spoj prečke u ramu (lijevi) - Cap for lower joint mullion in frame (left)	Tvrda guma Hard rubber	
363.061		- Čep za donji spoj prečke u ramu (desni) - Cap for lower joint mullion in frame (right)	Tvrda guma Hard rubber	

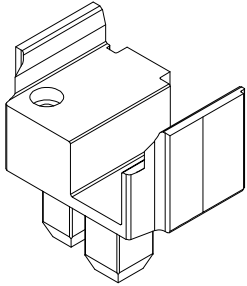
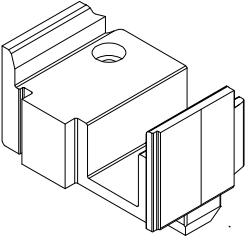
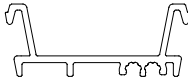
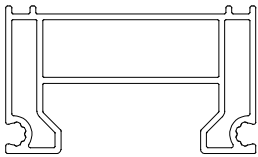
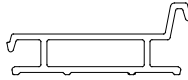
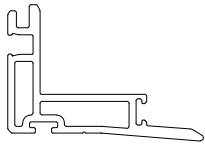
Oznaka Code	Izgled-presjek View - cross section	Opis Description	Materijal Material	Napomena Remark
363.075		<ul style="list-style-type: none"> <li>- Čep za spojni profi FT-1030 (lijevi) (za ugradnju usporivača krila HS COMFORT CLOSE)</li> <li>- Cap for sash joint profile (left) (for sash retarder HS COMFORT CLOSE)</li> </ul>	Tvrda guma Hard rubber	
363.076		<ul style="list-style-type: none"> <li>- Čep za spojni profi FT-1030 (desni) (za ugradnju usporivača krila HS COMFORT CLOSE)</li> <li>- Cap for sash joint profile (right) (for sash retarder HS COMFORT CLOSE)</li> </ul>	Tvrda guma Hard rubber	
378.002		<ul style="list-style-type: none"> <li>- Pvc umetak u donjem pojasu rama FT-1001; FT-1004 (Termo 150)</li> <li>- Pvc insert in lower position of frame FT-1001; FT-1004 (Termo 150)</li> </ul>	PA66G25 (STANDARD)	
378.003		<ul style="list-style-type: none"> <li>- Pvc umetak u gornjem vodoravnom pojasu rama FT-1000F (Termo 150)</li> <li>- Pvc insert in upper horizontal position of frame FT-1000F (Termo 150)</li> </ul>	PA66G25 (STANDARD)	
378.004		<ul style="list-style-type: none"> <li>- Pvc umetak u okomitom pojasu rama FT-1002F</li> <li>- Pvc insert in vertical position of frame FT-1002F</li> </ul>	PA66G25 (STANDARD)	
372.004		<ul style="list-style-type: none"> <li>- Pvc umetak na spoju krila (FT-1020)</li> <li>- Pvc insert on sash joint (FT-1020)</li> </ul>	ABS	

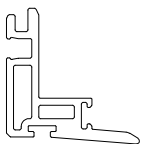
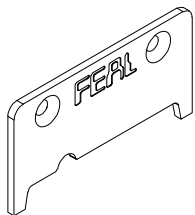
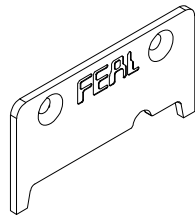
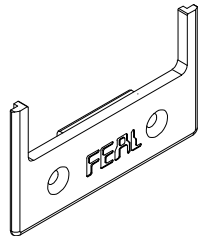
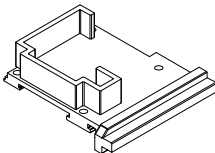
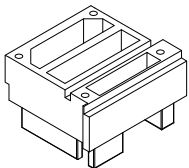
Oznaka Code	Izgled-presjek View - cross section	Opis Description	Materijal Material	Napomena Remark
372.005		- Pvc umetak na spoju krila (FT-1021) - Pvc insert on sash joint (FT-1021)	ABS	
373.051		- Čep maske krila u donjem pojasu (lijevi) - Sash mask cap in lower position (left)	PVC	
373.052		- Čep maske krila u donjem pojasu (desni) - Sash mask cap in lower position (right)	PVC	
373.053		- Čep maske krila u gornjem pojasu - Sash mask cap in upper position	PVC	
373.067		Donji umetak za prečku FT-1131F (Termo 150 Plus) Umetak 373.067 koristiti za podizno-klizna vrata s integriranim desnim fiksnim poljem (gledajući iznutra) Lower insert for mullion FT-1131F (Termo 150 Plus) Insert 373.067 use for lifting-sliding doors with integrated right fixed field (inside looking)	Tvrda guma	
373.068		Gornji umetak za prečku FT-1131F (Termo 150 Plus) Umetak 373.068 koristiti za podizno-klizna vrata s integriranim desnim fiksnim poljem (gledajući iznutra) Upper insert for mullion FT-1131F (Termo 150 Plus) Insert 373.068 use for lifting-sliding doors with integrated right fixed field (inside looking)	Tvrda guma	

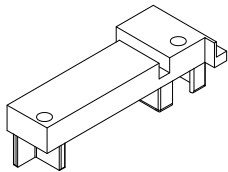
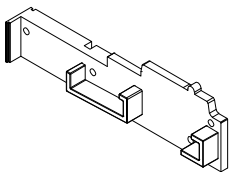
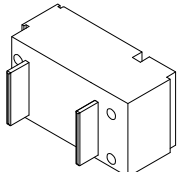
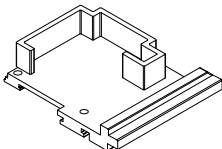
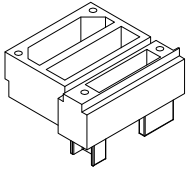
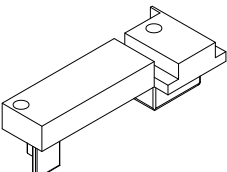
Oznaka Code	Izgled-presjek View - cross section	Opis Description	Materijal Material	Napomena Remark
373.069		Gornji umetak za malu prečku FT-1130F (Termo 150 Plus) Umetak 373.069 koristiti za podizno-klizna vrata s integriranim desnim fiksnim poljem (gledajući iznutra) Upper insert for mullion FT-1130F (Termo 150 Plus) Insert 373.069 use for lifting-sliding doors with integrated right fixed field (inside looking)	Tvrda guma	
373.070		Donji bočni umetak na spoju profila FT-1102F i FT-1103F (Termo 150 Plus) Umetak 373.070 koristiti za podizno-klizna vrata s integriranim desnim fiksnim poljem (gledajući iznutra) Lower side insert at profile joint FT-1102F and FT-1103F (Termo 150 Plus) Insert 373.070 use for lifting-sliding doors with integrated right fixed field (inside looking)	Tvrda guma	
373.071		Gornji bočni umetak na spoju profila FT-1101F i FT-1103F (Termo 150 Plus) Umetak 373.071 koristiti za podizno-klizna vrata s integriranim desnim fiksnim poljem (gledajući iznutra) Upper side insert at profile joint FT-1101F i FT-1103F (Termo 150 Plus) Insert 373.071 use for lifting-sliding doors with integrated right fixed field (inside looking)	Tvrda guma	
373.072		Donji umetak za prečku FT-1131F (Termo 150 Plus) Umetak 373.072 koristiti za podizno-klizna vrata s integriranim lijevim fiksnim poljem (gledajući iznutra) Lower insert for mullion FT-1131F (Termo 150 Plus) Insert 373.072 use for lifting-sliding doors with integrated left fixed field (inside looking)	Tvrda guma	
373.073		Gornji umetak za prečku FT-1131F (Termo 150 Plus) Umetak 373.073 koristiti za podizno-klizna vrata s integriranim lijevim fiksnim poljem (gledajući iznutra) Upper insert for mullion FT-1131F (Termo 150 Plus) Insert 373.073 use for lifting-sliding doors with integrated left fixed field (inside looking)	Tvrda guma	
373.074		Gornji umetak za malu prečku FT-1130F (Termo 150 Plus) Umetak 373.074 koristiti za podizno-klizna vrata s integriranim lijevim fiksnim poljem (gledajući iznutra) Upper insert for mullion FT-1130F (Termo 150 Plus) Insert 373.074 use for lifting-sliding doors with integrated left fixed field (inside looking)	Tvrda guma	

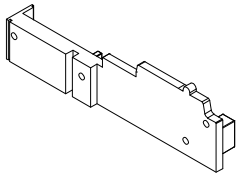
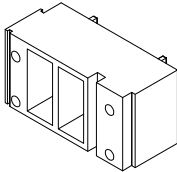
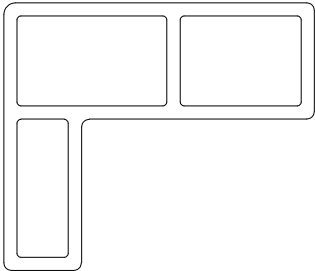
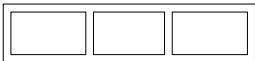
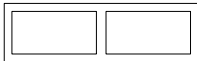
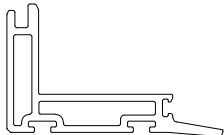
Oznaka Code	Izgled-presjek View - cross section	Opis Description	Materijal Material	Napomena Remark
373.075		Donji bočni umetak na spoju profila FT-1102F i FT-1103F (Termo 150 Plus) Umetak 373.075 koristiti za podizno-klizna vrata s integriranim lijevim fiksnim poljem (gledajući iznutra) Lower side insert at profile joint FT-1102F and FT-1103F (Termo 150 Plus) Insert 373.075 use for lifting-sliding doors with integrated left fixed field (inside looking)	Tvrda guma	
373.076		Gornji bočni umetak na spoju profila FT-1101F i FT-1103F (Termo 150 Plus) Umetak 373.076 koristiti za podizno-klizna vrata s integriranim lijevim fiksnim poljem (gledajući iznutra) Upper side insert at profile joint FT-1101F i FT-1103F (Termo 150 Plus) Insert 373.076 use for lifting-sliding doors with integrated left fixed field (inside looking)	Tvrda guma	
374.037		- PVC profil za ugradnju - Stara oznaka PI-110 - PVC profile for installation - Former code: PI-110	PVC	
374.069	 M1:2	- PVC profil za ugradnju (65x15) - PVC profile for installation (65x15)	PVC	
374.070	 M1:2	- PVC profil za ugradnju (50x15) - PVC profile for installation (50x15)	PVC	
374.078		- Pvc umetak na spoju krila (FT-1022) - Pvc insert on sash joint (FT-1022)	PVC	

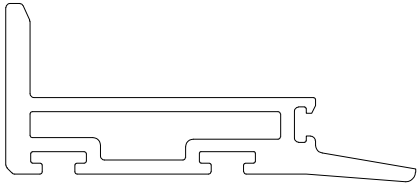
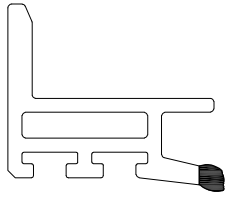
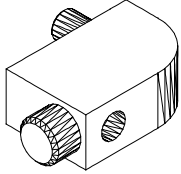
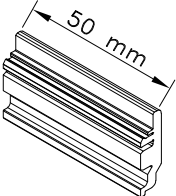
Oznaka Code	Izgled-presjek View - cross section	Opis Description	Materijal Material	Napomena Remark
374.083		PVC profil na spoju krila i prečke (FT-1120 FT-1131) T150 plus - PVC profile on two sash joint (large sash)	PVC	
374.120		- PVC profil na spoju krila i prečke (malo krilo F T-1121 i FT-1122) - PVC profile on two sash joint (small sash) FT-1121 i Ft-1122	PVC	
375.020		- Ublaživač udara krila - Stara oznaka OK-120-01 - Sash bumper(buffer) - Former code OK-120-01	PVC i EPDM	
375.048		- Kopča za profil F-1298 - Oznaka proizvođača: K116 - Clamp for profile F-1298 - Former code :K116	PVC	
373.078		-Usmjerivač krila -Minimalno četiri po krilu -Sash guide -Minimum of four per sash	PVC	
364.021		-Dilatacijski čep za prag FT-1001 i FT-1004 -Dilatation cap of the treshold FT-1001 & Ft-1004	ABS	

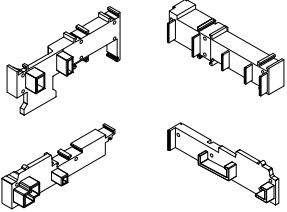
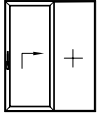
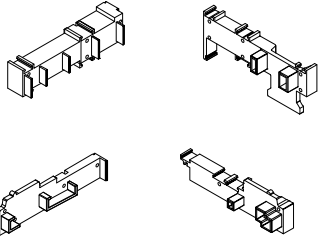
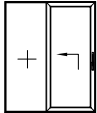
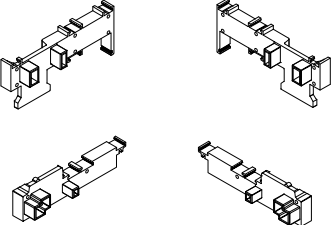
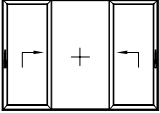
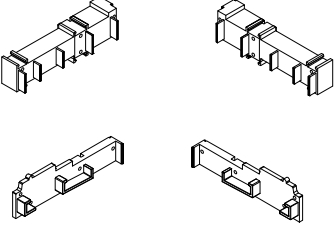
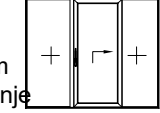
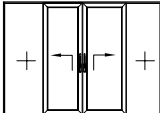
Oznaka Code	Izgled-presjek View - cross section	Opis Description	Materijal Material	Napomena Remark
374.122		- Pvc umetak pod kotače koristi se za malo krilo FT-1020F (Termo 150) - PVC profile under rollers used for small sash FT1020 (Termo 150)	PVC	
373.086		-Set umetaka za spoj okvira -Za lijeva dvokrilna vrata (Termo 150plus)-ravno pilanje rama  -Set of inserts for frame connection -For left double doors (Termo 150plus)-straight sawing of the frame	Tvrda guma	90±5 ShA
373.087		-Set umetaka za spoj okvira -Za desna dvokrilna vrata (Termo 150plus)-ravno pilanje rama  -Set of inserts for frame connection -For the right double door (Termo 150plus) - straight sawing of the frame	Tvrda guma	90±5 ShA
373.088		-Set umetaka za spoj okvira -Za dvokrilna vrata sa srednjim fiksnim poljem i kliznim bočnim krilima (Termo 150plus)-ravno pilanje rama  -Set of inserts for frame connection -For the right double door with middle fixed field (Termo 150plus) - straight sawing of the frame	Tvrda guma	90±5 ShA
373.089		-Set umetaka za spoj okvira -Za četverokrilna vrata sa dva srednja klizna krila i bočnim fiksnim poljem (Termo 150plus)-ravno pilanje rama  -Set of inserts for frame connection -For the right double sash door with middle sliding sash and lateral fixed field (Termo 150plus) - straight sawing of the frame 	Tvrda guma	90±5 ShA

# Mehanizmi Mechanisms



- Popis elemenata s kodovima Hautau Atrium HS 200 i Feal  
- Item description with codes of Hautau Atrium HS 200 and Feal

D	H	F	Naziv dijela i pozicija Part Name and position	Šifra dijela Hautau Item code (Hautau)	Šifra dijela Feal Item code (Feal)	
2	3	4	Set kotača HS 200 Bogie, handle side (1) (2) (42) (42a)	193720	149.054	
2	3	4	Dodaci Alu-HS 200 Accessories Alu-HS 200 (10) (11) (12) (13)	189490	149.047	
2	3	4	Set ručke (HAUTAU DESIGN) Carton handle set (HAUTAU-DESIGN) (4) (30)	str. 406.08.011 page 406.08.011	str. 406.08.011 page 406.08.011	
2	3	4	Brava HS 200 (3) Espag HS 200	Gr. 180 1200-1800 210 1801-2100 240 2101-2400 270 2401-2700	Fh. 1200-1800 1801-2100 2101-2400 2401-2700	195419 149.007 195425 149.008 195431 149.009 195437 149.010
2	3	4	Spojnicica kotača (5) Connection rod	Gr. 150 650-1360 200 1361-1860 250 1861-2360	Fh. 650-1360 1361-1860 1861-2360	184578 149.011 184581 149.012 184584 149.013
2	3	4	Podloške (9) Packers	196448		
2	4	4	Dodaci za odbojnik krila (18) Accessories Sash buffer, top	Bijela Crna Siva White Black Grey 187480 187477 239855	149.024	
4	4	8	Zapinjač na ramu (6) Locking bolt	184809	149.025	
2	2	4	*Zapinjač na ramu, noćna ventilacija (7) *Locking bolt (night vent)	184749	149.026	
2	3	4	Dodatni vijci (14) Accessories screws	198105	149.027	

\*Opcija  
\*Option

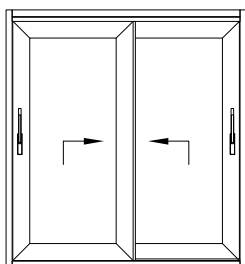

Shema D  
Schema D

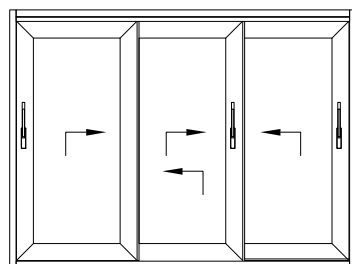

Shema H  
Schema H

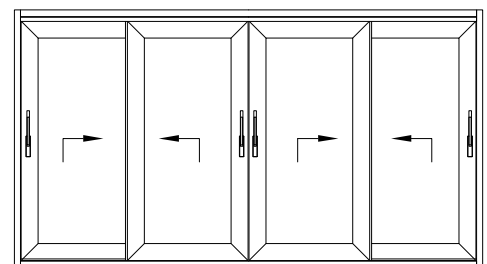

Shema F  
Schema F

### HAUTAU ATRIUM ALU-HS 200 HAUTAU ATRIUM ALU-HS 200

Poz.Pos.	Naziv dijela Part Name	Poz.Pos.	Naziv dijela Part Name
1	Kotači, na strani ručke Bogie handle side	12	Čep Cap
2	Kotači Bogie	13	Pričvrstne matice za točkice Growed pin
3	Brava Espag	14	Vijci Screws
4	LM ručka s vijcima LM handle incl.screws	18	Odbojnik krila, gore Sash buffer, top (optional)
5	Spojnica kotača Connection rod	30	Vanjski rukohvatnik External finger grip
6	Zapinjač na ramu Locking bolt	42	Podmetač za točkice 22mm žlijeb Spacer for bogie HS 200 (22mm groove)
7	Zapinjač na ramu za noćnu ventilaciju Locking bolt,night vent	42a	Podmetač za točkice 18mm žlijeb Spacer for bogie HS 200 (18mm groove)
9	PVC podloška pod bravu PVC packer under to lock		
10	Odbojnik krila Sash buffer		
11	Samopričvrstni spojni vijci Connecting screw self trapping		

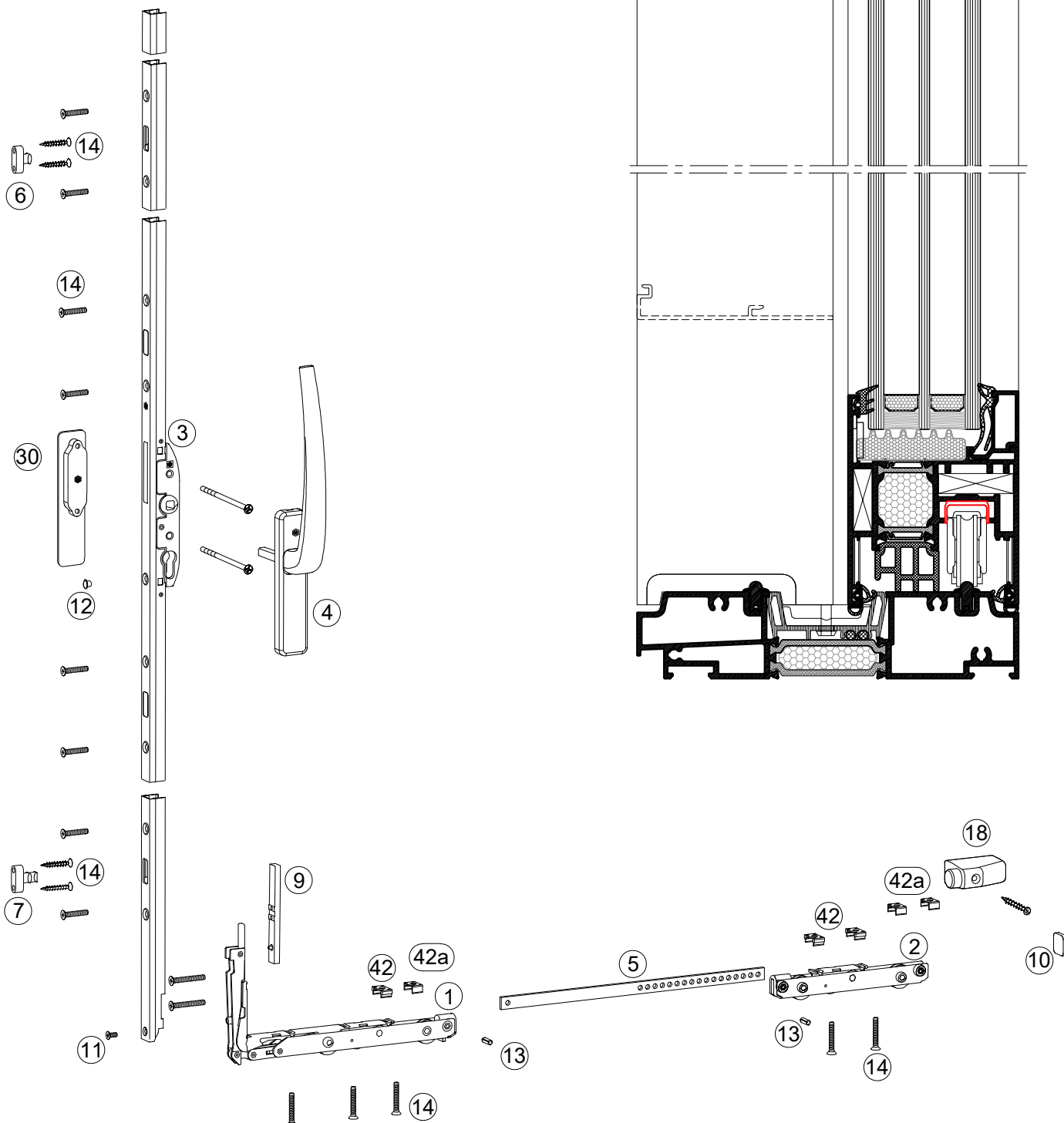
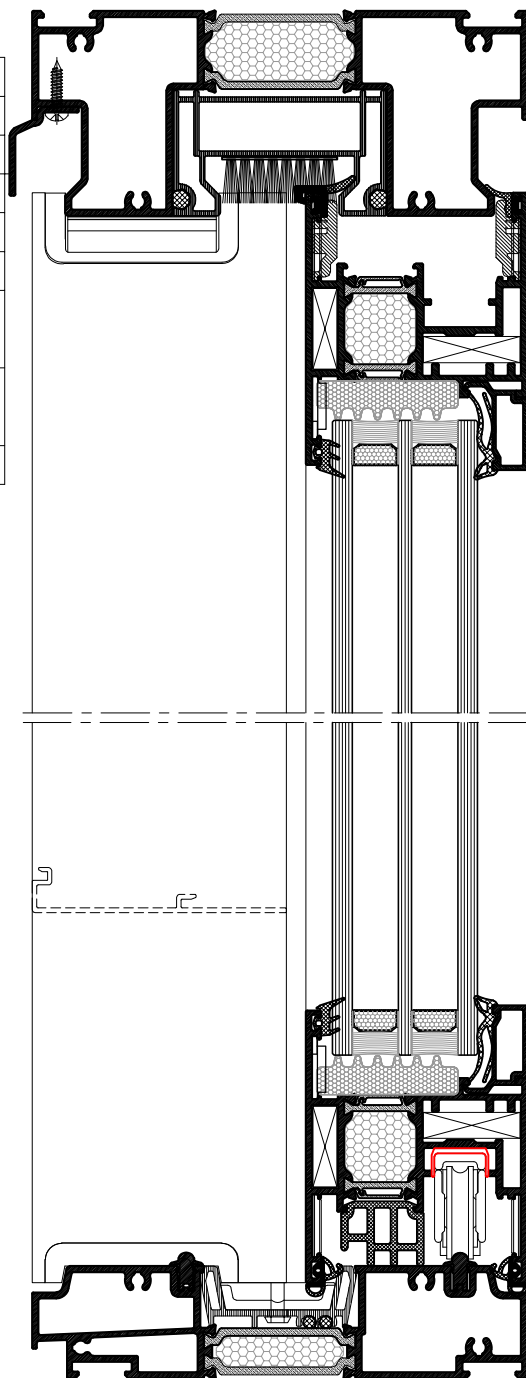

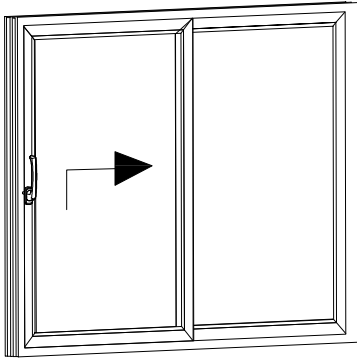

- Osnovni set za podizno klizna vrata (**HAUTAU**).....**149.054**
- Basic set for lift and slide door (**HAUTAU**).....**149.054**

### PODIZNO-KLIZNI MEHANIZAM ATRIUM Alu-HS 200 (HS 200)-(HAUTAU)

-za krilo FT-1020F

-težina krila max. 200 kg

-mjere krila Fb x Fh = (650-2360) x (1200-2700)

-položaj ručke

-vrata (Fh 1801-2700)..... 1004 mm

LIFT-SLIDE MECHANISM ATRIUM Alu-HS (HS 200)-(HAUTAU)

-for sash FT-1020F

-sash weight max. 200 kg

-sash measurements Fb x Fh = (650-2360) x (1200-2700)

-hande position

-door (Fh 1801-2700)..... 1004 mm

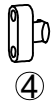

Poz.Pos.	Naziv dijela Part Name	Oznaka proizvođača Manufacturer code	Kom.Num.
1	Kotači za Atrium Alu-HS 200 Bogies Atrium Alu-HS 200	193720	1
2	Pričvrzne matice za meh. i kotačiće Grooved pin	188636	1
3	PVC podloška pod bravu PVC packer under to lock	196448	1
4	Zatvarači Locking bolt	184809	2

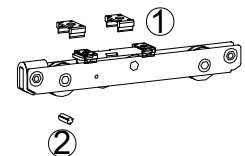
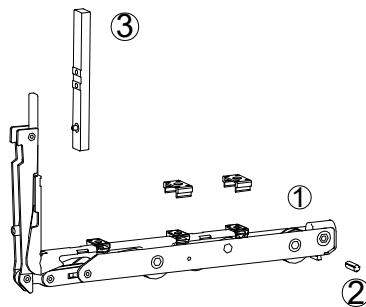

### Montažne mjere za podizno-klizni mehanizam ATRIUM ALU-HS 200

Mounting measurements for lift and slide mechanism ATRIUM ALU-HS 200

Montaža prihvatnika na ramu  
Mounting acceptor on frame



	A	B	C
Gr.180	-	600	1000
Gr.210	750	1200	1600
Gr.240	750	1200	1900
Gr.270	750	1200	2200

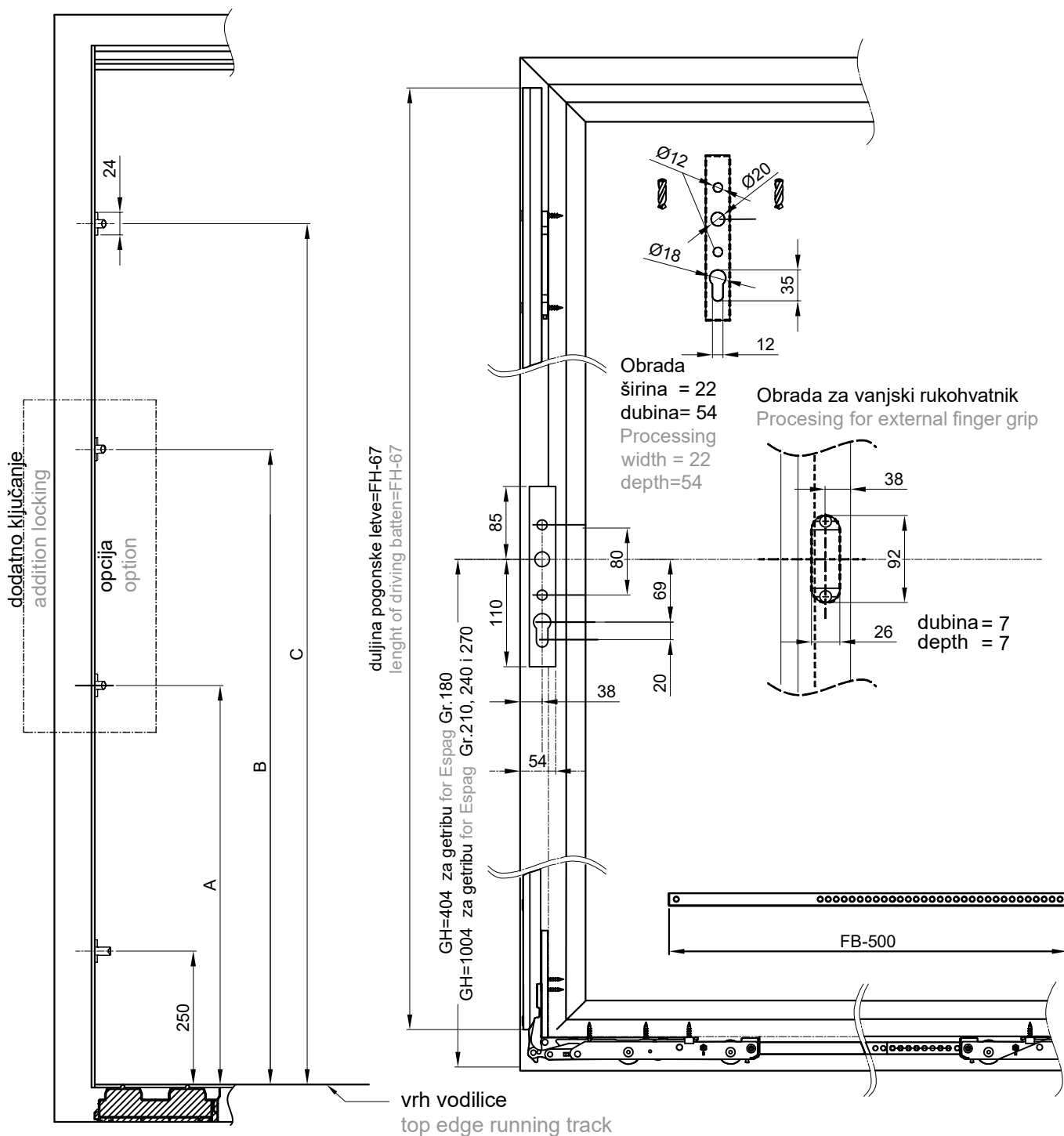
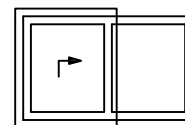

### - Popis elemenata s kodovima Hautau Atrium HS 330 i Feal

### - Item description with codes of Hautau Atrium HS 330 and Feal

A	D	C	F	G	H	Naziv dijela i pozicija Part Name and position	Šifra dijela Hautau Item code (Hautau)	Šifra dijela Feal Item code (Feal)	
1	2	2	4	1	3	Set kotača HS 330 Bogle, handle side ①②⑥⑦⑧⑨⑩⑪⑫⑬⑭⑮	303126	149.035	
1	2	2	4	1	3	Set ručke (HAUTAU DESIGN) Carton handle set (HAUTAU-DESIGN) with accessories ④ ③⑩	str. 406.08.011 page 406.08.011	str. 406.08.011 page 406.08.011	
1	2	2	4	1	3	Brava HS 330 D 37,5 ③ Espag HS 330 D 37,5	Gr. 180 1200-1800 210 1801-2100 240 2101-2400 270 2401-2700	184307 184313 184319 184325	149.019 149.020 149.021 149.022
1	2	2	4	1	3	Spojnica kotača ⑤ Connection rod	Gr. 150 720-1500 200 1501-2000 250 2001-2500 323 2501-3235	184578 184581 184584 184587	149.011 149.012 149.013 149.014
2	2	4	4	2	3	Dodaci za odbojnik krila ⑮ Accessories Sash buffer, top	Bijela Crna Siva White Black Grey 187480 187477 239855	149.024	
2	4	8	2	2	3	Zapinjač na ramu ⑥ Locking bolt	184809	149.025	
1	2	4	2	1	4	*Zapinjač na ramu, noćna ventilacija ⑦ *Locking bolt (night vent)	184749	149.026	
1	2	2	2	1	3	Dodatni vijci ⑭ Accessories screws	198105	149.027	

\*Opcija  
\*Option

### Termo 150

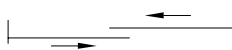
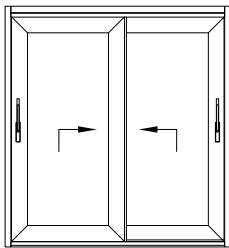

Schema D  
Schema D

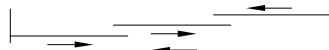
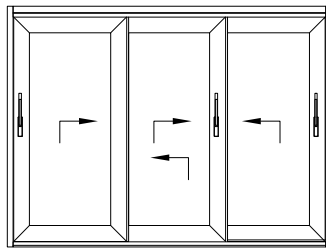

Schema H  
Schema H

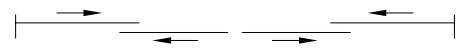
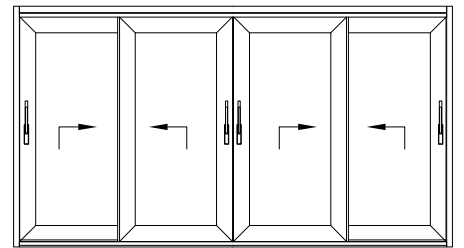

Schema F  
Schema F

### Termo 150 plus

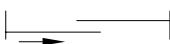
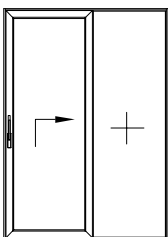

Schema A  
Schema A

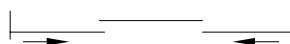
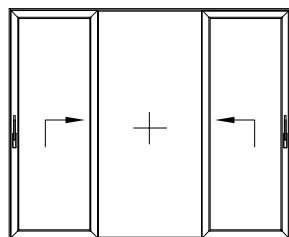

Schema D  
Schema D

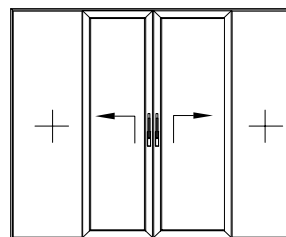

Schema C  
Schema C

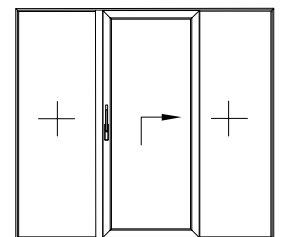

Schema G  
Schema G

### HAUTAU ATRIUM ALU-HS 330

Poz.Pos.	Naziv dijela Part Name	Poz.Pos.	Naziv dijela Part Name
1	Kotači, na strani ručke Bogie handle side	11	Samopričvrсни spojni vijci Connecting screw self trapping
2	Kotači Bogie	12	Čep Cap
3	Brava Espag	13	Pričvršne matice za točkice Growed pin
4	LM ručka s vijcima LM handle incl.screws	14	Vijci Screws
5	Spojnica kotača Connection rod	18	Odbojnik krila, gore Sash buffer, top (optional)
6	Zapinjač na ramu Locking bolt	300a	Set ručke s rukohvatom Carton handle set
7	Zapinjač na ramu za noćnu ventilaciju Locking bolt,night vent		
8	Podmetači pod bravu Packer espag.		
9	PVC podloškatočkice PVC packer under to bogie		
10	Odbojnik krila Sash buffer		

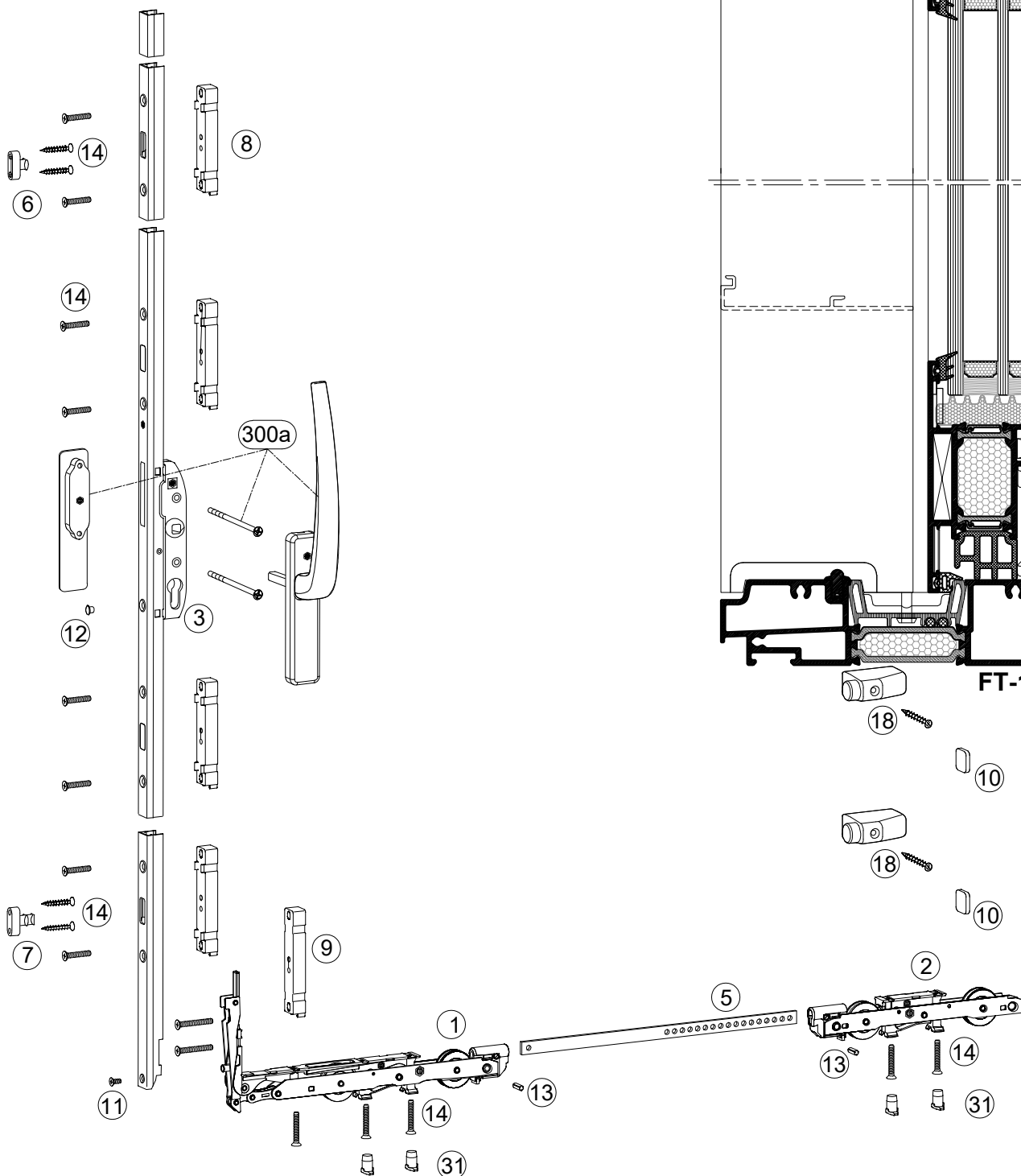
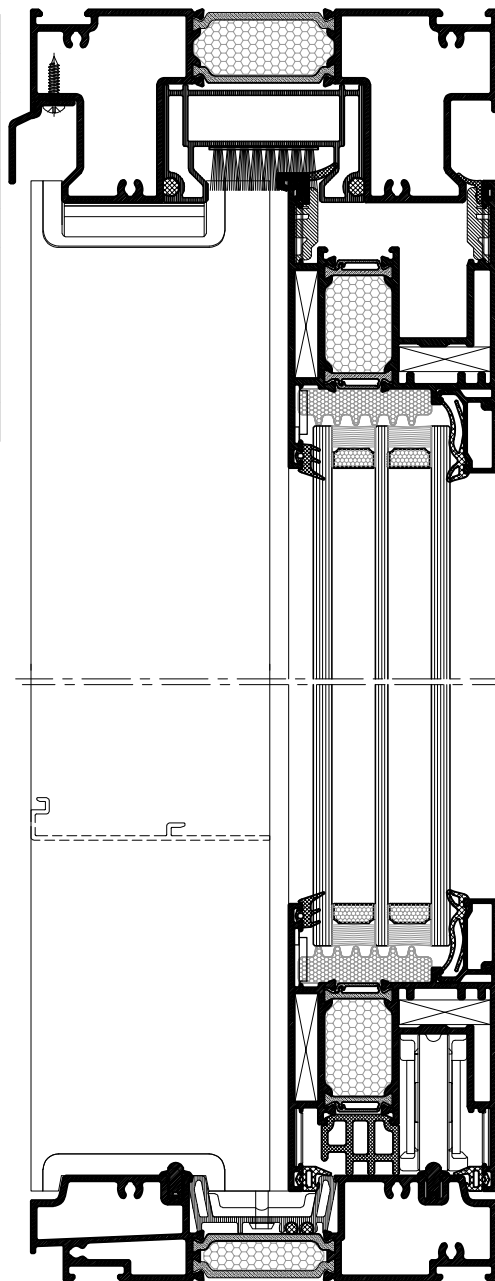

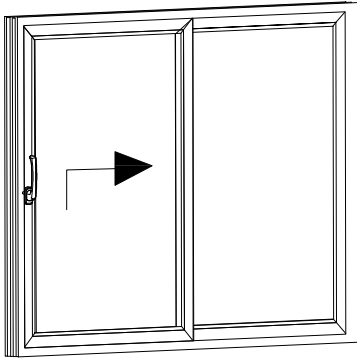

- Osnovni set za podizno klizna vrata (**HAUTAU**).....**149.035**
- Basic set for lift and slide door (**HAUTAU**).....**149.035**

### PODIZNO-KLIZNI MEHANIZAM ATRIUM Alu-HS 300 (HS 200)-(HAUTAU) -za krilo FT-1120F i FT-1022F

- težina krila max. 330 kg
- mjere krila Fb x Fh = (720-3235) x (1200-2700 (3300\*))
- položaj ručke
- vrata (Fh 1801-2700)..... 1004 mm

### LIFT-SLIDE MECHANISM ATRIUM Alu-HS 300 (HS 200)-(HAUTAU)

- for sash FT-1120F and FT-1022F
- sash weight max. 330 kg
- sash measurements Fb x Fh = (720-3235) x (1200-2700 (3300\*))
- hande position
- door (Fh 1801-2700)..... 1004 mm

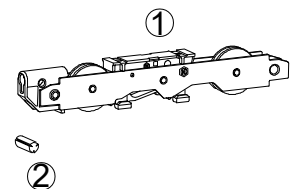
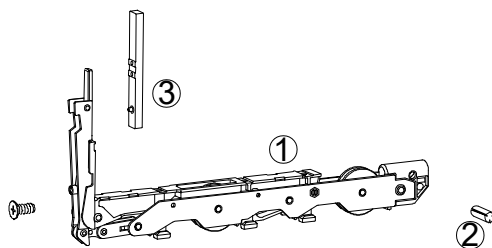
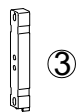
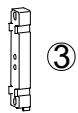
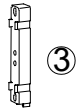
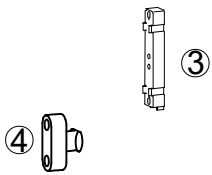

Poz.Pos.	Naziv dijela Part Name	Oznaka proizvođača Manufacturer code	Kom.Num.
1	Kotači za Atrium Alu-HS 330 Bogies Atrium Alu-HS 330	302311	1
2	Pričvrzne matice za meh. i kotačice Grooved pin	188636	1
3	PVC podloške pod bravu PVC packer under to lock	189038	1
4	Zatvarači Locking bolt	184809	2

### Montažne mjere za podizno-klizni mehanizam ATRIUM ALU-HS 330

### Mounting measurements for lift and slide mechanism ATRIUM ALU-HS 330

Montaža prihvatnika na ramu u seriji T 150  
Mounting acceptor on frame in system T150

	A	B	C
Gr.180	-	600	1000
Gr.210	750	1200	1600
Gr.240	750	1200	1900
Gr.270	750	1200	2200



\*Montaža prihvatnika u seriji T150 plus  
Mounting acceptor on frame in system T150



*	A	B	C
Gr.180	-	604	1004
Gr.210	754	1204	1604
Gr.240	754	1204	1904
Gr.270	754	1204	2204

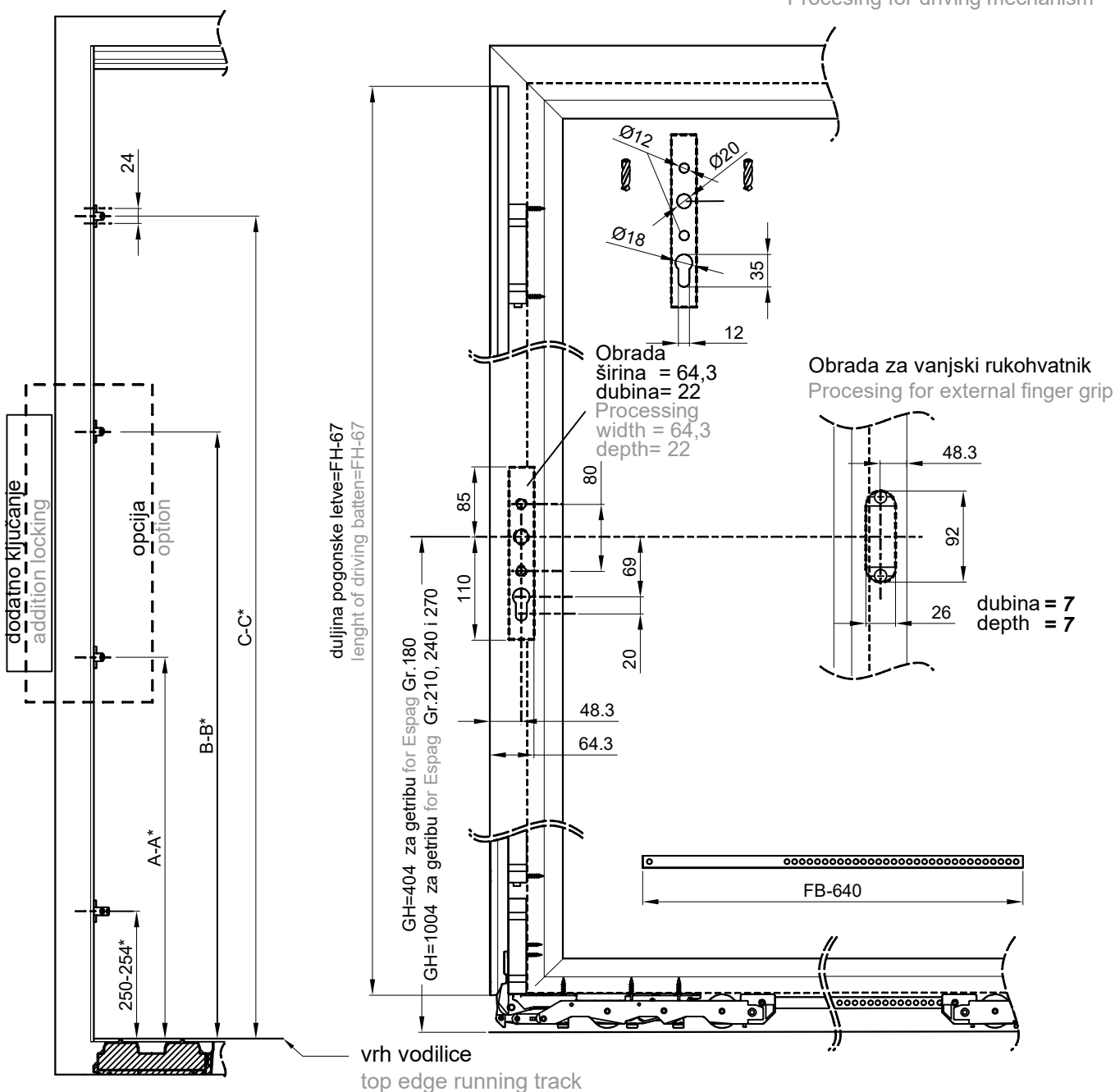



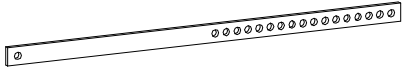

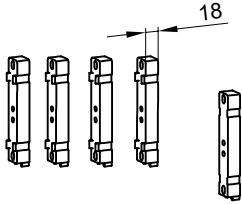
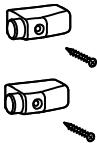
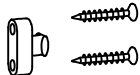
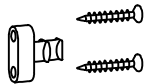
Obrada za pogonski mehanizam  
Processing for driving mechanism



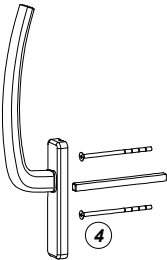
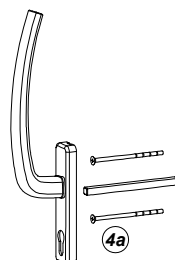

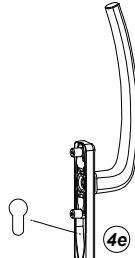
Oznaka Code	Izgled-presjek View- cross section	Opis Description	Materijal Material	Napomena Remark
149.007		- Brava za ključanje HS 200 vel. 180 - Oznaka proizvođača 195419 (Fh 1200-1800) - Espagnolette HS 200 size 180 - Manufacturer code 195419 (Fh 1200-1800)		
149.008		- Brava za ključanje HS 200 vel. 210 - Oznaka proizvođača 195425 (Fh 1801-2100) - Espagnolette HS 200 size 210 - Manufacturer code 195425 (Fh 1801-2100)		
149.009		- Brava za ključanje HS 200 vel. 240 - Oznaka proizvođača 195431 (Fh 2101-2400) - Espagnolette HS 200 size 240 - Manufacturer code 195431 (Fh 2101-2400)		
149.010		- Brava za ključanje HS 200 vel. 270 - Oznaka proizvođača 195437 (Fh 2401-2700) - Espagnolette HS 200 size 270 - Manufacturer code 195437 (Fh 2401-2700)		
149.019		- Brava za ključanje HS 300 vel. 180 - Oznaka proizvođača 184307 (Fh 1200-1800) - Espagnolette HS 300 size 180 - Manufacturer code 184307 (Fh 1200-1800)		
149.020		- Brava za ključanje HS 300 vel. 210 - Oznaka proizvođača 184313 (Fh 1801-2100) - Espagnolette HS 300 size 210 - Manufacturer code 184313 (Fh 1801-2100)		
149.021		- Brava za ključanje HS 300 vel. 240 - Oznaka proizvođača 184319 (Fh 2101-2400) - Espagnolette HS 300 size 240 - Manufacturer code 184319 (Fh 2101-2400)		
149.022		- Brava za ključanje HS 300 vel. 270 - Oznaka proizvođača 184325 (Fh 2401-2700) - Espagnolette HS 200 size 270 - Manufacturer code 195437 (Fh 2401-2700)		
149.011		- Spojnica kotačića vel. 150 (HAUTAU) - Oznaka proizvođača 184578 (Fb 720-1500) - Connection rod size 150 (HAUTAU) - Manufacturer code 184578 (Fb 720-1500)		
149.012		- Spojnica kotačića vel. 200 - Oznaka proizvođača 184581 (Fb 1501-2000) - Connection rod size 200 - Manufacturer code 184581 (Fb 1501-2000)		
149.013		- Spojnica kotačića vel. 250 - Oznaka proizvođača 184584 (Fb 2001-2500) - Connection rod size 250 - Manufacturer code 184584 (Fb 2001-2500)		
149.014		- Spojnica kotačića vel. 323 - Oznaka proizvođača 184587 (Fb 2501-3235) - Connection rod size 323 - Manufacturer code 184587 (Fb 2501-3235)		

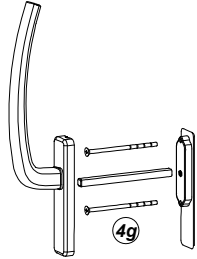
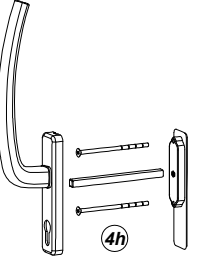
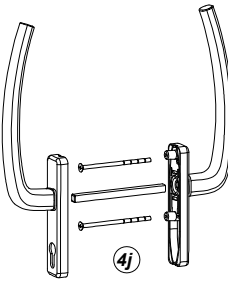
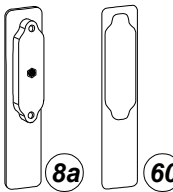
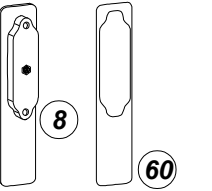
Oznaka Code	Izgled-presjek View- cross section	Opis Description	Materijal Material	Napomena Remark
149.023		<ul style="list-style-type: none"> <li>- Umetci za bravu i kotačiće</li> <li>- Oznaka proizvođača 189038</li> <li>-Za Termo 150</li> </ul>	Hautau	Termo 150
149.024		<ul style="list-style-type: none"> <li>- Zaustavljač krila set</li> <li>- Oznaka proizvođača..... 187480-bijeli 187477-crni 239855-sivi</li> <li>-Za Termo 150</li> </ul>	Hautau	Termo 150
149.025		<ul style="list-style-type: none"> <li>- Zapinjač na ramu</li> <li>- Oznaka proizvođača 184809</li> <li>- Locking bolt</li> <li>- Manufacturer code 184809</li> </ul>	Hautau	
149.026		<ul style="list-style-type: none"> <li>- Zapinjač na ramu (noćna ventilacija)</li> <li>- Oznaka proizvođača 184749</li> <li>- Locking bolt (night vent)</li> <li>- Manufacturer code 184749</li> </ul>	Hautau	
149.017		<ul style="list-style-type: none"> <li>- Donje ključanje-prag (HAUTAU)</li> <li>- Oznaka proizvođača:186934</li> <li>- Locking, bottom (HAUTAU)</li> <li>- Manufacturer code:186934</li> </ul>		

Oznaka Code	Izgled-presjek View- cross section	Opis Description	Materijal Material	Napomena Remark
108.001.01 03 04		<ul style="list-style-type: none"> <li>- Unutarnja ručka (bez vanjskog prihvatnika)</li> <li>- Oznaka proizvođača   na upit       (RAL 9016)                                   196859       (crna)                                   na upit       (natural)</li> <li>- Interior handle (without external grip)</li> <li>- Manufacturer code    on req.       (RAL 9016)                                   196859       (black)                                   on req.       (natural)</li> </ul>	Hautau	
108.002.01 03 04		<ul style="list-style-type: none"> <li>- Unutarnja ručka sa cilindrom za ključanje (bez vanjskog prihvatnika)</li> <li>- Oznaka proizvođača   na upit       (RAL 9016)                                   196871       (crna)                                   na upit       (natural)</li> <li>- Interior handle with cylinder for locking (without external grip)</li> <li>- Manufacturer code    on req.       (RAL 9016)                                   196871       (black)                                   on req.       (natural)</li> </ul>	Hautau	
108.003.01 03 04		<ul style="list-style-type: none"> <li>- Unutarnja ručka (bez vanjskog prihvatnika i osovine)</li> <li>- Oznaka proizvođača   246212       (RAL 9016)                                   246272       (crna)                                   246182       (natural)</li> <li>Interior handle (without external grip and axel)</li> <li>- Manufacturer code    246212       (RAL 9016)                                   246272       (black)                                   246182       (natural)</li> </ul>	Hautau	
108.004.01 03 04		<ul style="list-style-type: none"> <li>- Unutarnja ručka sa cilindrom za ključanje (bez vanjskog prihvatnika i osovine)</li> <li>- Oznaka proizvođača   246215       (RAL 9016)                                   246275       (crna)                                   246185       (natural)</li> <li>- Interior handle with locking cylinder (without external grip and axel)</li> <li>- Manufacturer code    246215       (RAL 9016)                                   246275       (black)                                   246185       (natural)</li> </ul>	Hautau	
108.005.01 03 04		<ul style="list-style-type: none"> <li>- Vanjska ručka sa cilindrom za ključanje (bez osovine)</li> <li>- Oznaka proizvođača   246218       (RAL 9016)                                   246278       (crna)                                   246188       (natural)</li> <li>- External handle with locking cylinder (without axle)</li> <li>- Manufacturer code    246218       (RAL 9016)                                   246278       (black)                                   246188       (natural)</li> </ul>	Hautau	

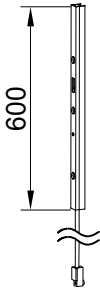
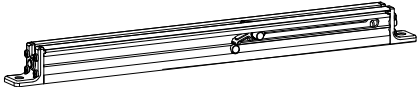
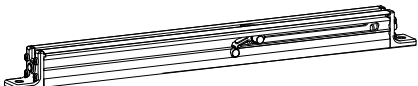
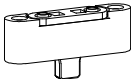
Oznaka Code	Izgled-presjek View- cross section	Opis Description	Materijal Material	Napomena Remark
108.006.01 03 04		<ul style="list-style-type: none"> <li>- Unutarnja ručka -set</li> <li>- Oznaka proizvođača 191554 (RAL 9016)</li> <li>193615 (crna)</li> <li>204553 (natural)</li> <li>- Interior handle-set</li> <li>- Manufacturer code 191554 (RAL 9016)</li> <li>193615 (black)</li> <li>204553 (natural)</li> </ul>	Hautau	
108.007.01 03 04		<ul style="list-style-type: none"> <li>- Unutarnja ručka-set (sa cilindrom za ključanje)</li> <li>- Oznaka proizvođača 191557 (RAL 9016)</li> <li>193618 (crna)</li> <li>204556 (natural)</li> <li>- Interior handle (with locking cylinder)</li> <li>- Manufacturer code 191557 (RAL 9016)</li> <li>193618 (black)</li> <li>204556 (natural)</li> </ul>		
108.008.01 03 04		<ul style="list-style-type: none"> <li>- Pogonske ručke-set (sa cilindrom za ključanje)</li> <li>- Oznaka proizvođača 191563 (RAL 9016)</li> <li>193621 (crna)</li> <li>206863 (natural)</li> <li>- Driving handles - set (with locking cylinder)</li> <li>- Manufacturer code 191563 (RAL 9016)</li> <li>193621 (black)</li> <li>206863 (natural)</li> </ul>	Hautau	
108.013.01 03 04 06		<ul style="list-style-type: none"> <li>-Ravni vanjski rukohvatnik 6.5 mm</li> <li>-Oznaka proizvođača 217695 (RAL 9016)</li> <li>217704 (crna)</li> <li>217692 (natural)</li> <li>224262 (srebrena)</li> <li>-Brtva za vanjski rukohvatnik</li> <li>-Flat external finger grip 6.5 mm</li> <li>-Manufacturer code 217695 (RAL 9016)</li> <li>217704 (black)</li> <li>217692 (natural)</li> <li>224262 (silver)</li> <li>-Gasket for external finger grip</li> </ul>	Hautau	
108.009.01 03 04 06		<ul style="list-style-type: none"> <li>-Standardni vanjski rukohvatnik 9.5 mm</li> <li>- Oznaka proizvođača 185161 (RAL 9016)</li> <li>193600 (crna)</li> <li>185158 (natural)</li> <li>224259 (srebrena)</li> <li>-Brtva za vanjski rukohvatnik</li> <li>-Standard external finger grip</li> <li>-Manufacturer code 185161 (RAL 9016)</li> <li>193600 (black)</li> <li>185158 (natural)</li> <li>224259 (silver)</li> <li>-Gasket for external finger grip</li> </ul>		
108.014		<ul style="list-style-type: none"> <li>- vijci i osovinica</li> <li>- screws and axel</li> </ul>		

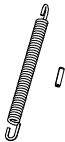
Oznaka Code	Izgled-presjek View- cross section	Opis Description	Materijal Material	Napomena Remark
149.045		<ul style="list-style-type: none"> <li>- Produžetak za bravu (za krila veća od 2700 mm)</li> <li>- Kompatibilan sa bravama AtriumHS 200/300</li> <li>Za krila visine 2700-3300 mm</li> <li>- Espag extension (for sash bigger 2700mm)</li> <li>-Compatible with espag Atrium HS 200/300</li> <li>-Sash height 2700-3000mm</li> </ul>		
149.030		<ul style="list-style-type: none"> <li>- Usporivač krila za težine krila ≤ 200 kg</li> <li>- Oznaka proizvođača:300359 (Atrium comfort close -HAUTAU)</li> <li>- Sash retarder for sash weight ≤ 200 kg</li> <li>- Manufacturer code:300359 (Atrium comfort close -HAUTAU)</li> </ul>		
149.031		<ul style="list-style-type: none"> <li>- Usporivač krila za težine krila &gt; 200....300 kg</li> <li>- Oznaka proizvođača:300360 (Atrium comfort close -HAUTAU)</li> <li>- Sash retarder for sash weight &gt; 200....300 kg</li> <li>- Manufacturer code:300360 (Atrium comfort close -HAUTAU)</li> </ul>		
149.032		<ul style="list-style-type: none"> <li>- Usporivač krila-dodatak na ramu</li> <li>- Oznaka proizvođača:300380 (Atrium comfort close -HAUTAU)</li> <li>- Sash retarder - addition on frame</li> <li>- Manufacturer code:300380 (Atrium comfort close -HAUTAU)</li> </ul>		
149.043		<ul style="list-style-type: none"> <li>- Opruga za bravu podizno kliznog mehanizma (lakše otvaranje ručke) za krilo težine &lt; 200 kg</li> <li>- Oznaka proizvođača:239654 (Atrium HS -Soft Lift-HAUTAU)</li> <li>- Spring assist system within the espag for sash weight &lt; 200 kg</li> <li>- Manufacturer code:239654 (Atrium HS -Soft Lift-HAUTAU)</li> </ul>		
149.044		<ul style="list-style-type: none"> <li>- Opruga za bravu podizno kliznog mehanizma (lakše otvaranje ručke) za krilo težine &gt; 200 kg</li> <li>- Oznaka proizvođača:239657 (Atrium HS -Soft Lift-HAUTAU)</li> <li>- Spring assist system within the espag for sash weight &gt; 200 kg</li> <li>- Manufacturer code:239657 (Atrium HS -Soft Lift-HAUTAU)</li> </ul>		

### Prikaz komponenti za motorni pogon

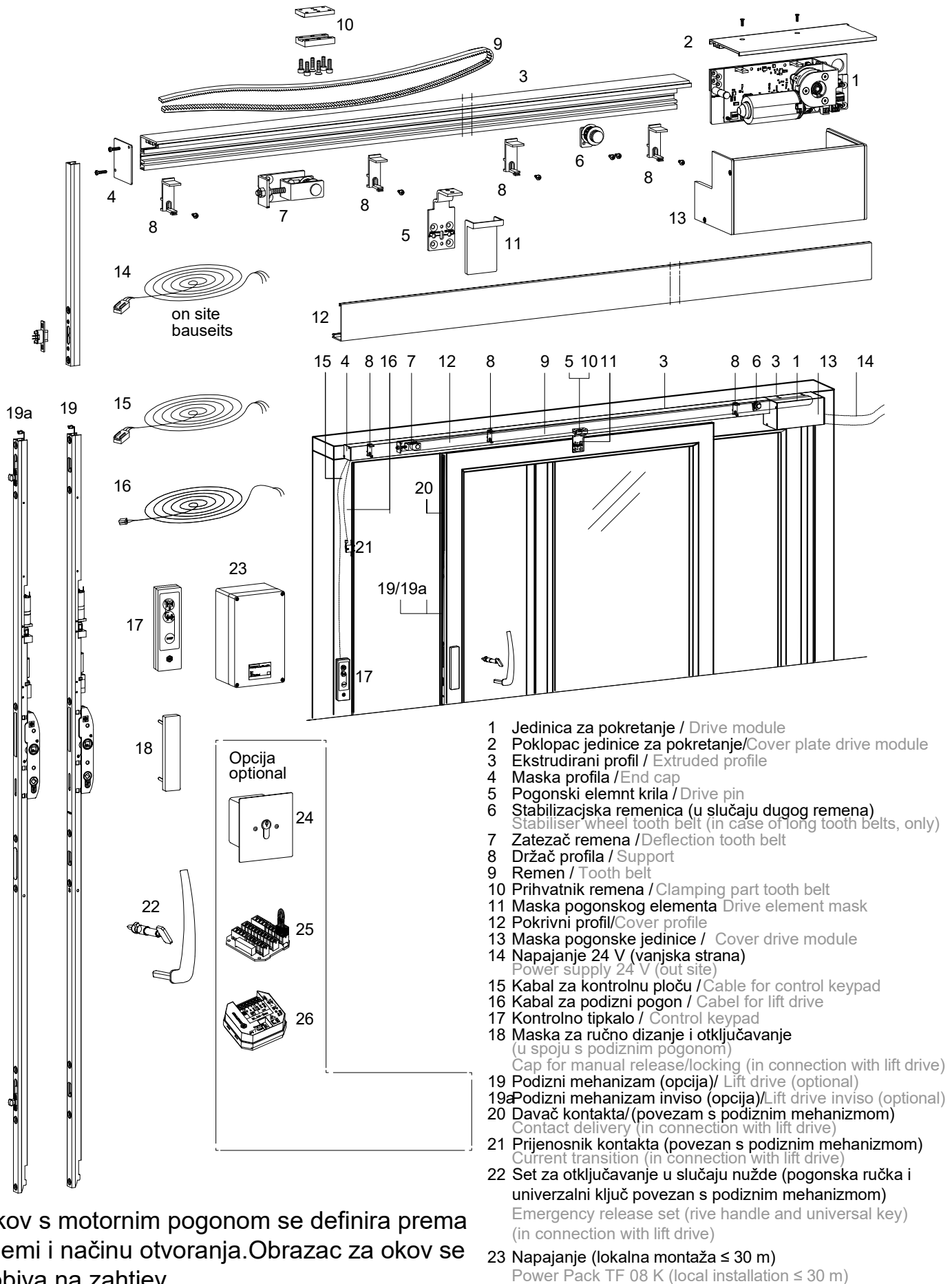

- 1 Jedinica za pokretanje / Drive module
- 2 Poklopac jedinice za pokretanje/Cover plate drive module
- 3 Ekstrudirani profil / Extruded profile
- 4 Maska profila /End cap
- 5 Pogonski elemnt krila / Drive pin
- 6 Stabilizacijska remenica (u slučaju dugog remena)  
Stabiliser wheel tooth belt (in case of long tooth belts, only)
- 7 Zatežać remena /Deflection tooth belt
- 8 Držać profila / Support
- 9 Remen / Tooth belt
- 10 Prihvatnik remena / Clamping part tooth belt
- 11 Maska pogonskog elementa Drive element mask
- 12 Pokrivni profil/Cover profile
- 13 Maska pogonske jedinice / Cover drive module
- 14 Napajanje 24 V (vanjska strana)  
Power supply 24 V (out site)
- 15 Kabal za kontrolnu ploču / Cable for control keypad
- 16 Kabal za podizni pogon / Cabel for lift drive
- 17 Kontrolno tipkalo / Control keypad
- 18 Maska za ručno dizanje i otključavanje  
(u spoju s podiznim pogonom)  
Cap for manual release/locking (in connection with lift drive)
- 19 Podizni mehanizam (opcija)/ Lift drive (optional)
- 19a Podizni mehanizam invisio (opcija)/Lift drive invisio (optional)
- 20 Davač kontakta/(povezam s podiznim mehanizmom)  
Contact delivery (in connection with lift drive)
- 21 Prijenosnik kontakta (povezan s podiznim mehanizmom)  
Current transition (in connection with lift drive)
- 22 Set za otključavanje u slučaju nužde (pogonska ručka i univerzalni ključ povezan s podiznim mehanizmom)  
Emergency release set (rive handle and universal key) (in connection with lift drive)
- 23 Napajanje (lokalna montaža ≤ 30 m)  
Power Pack TF 08 K (local installation ≤ 30 m)

Okov s motornim pogonom se definira prema shemi i načinu otvaranja. Obrazac za okov se dobiva na zahtjev.

# Brtila Gaskets



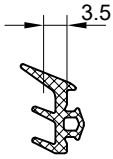
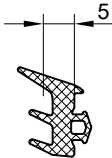
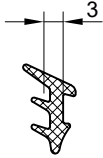
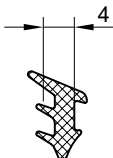
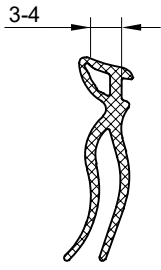
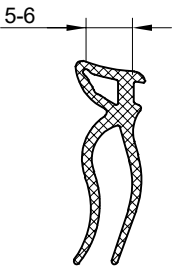

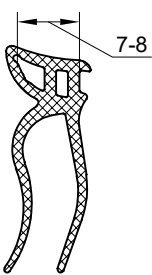
Oznaka Code	Izgled-presjek View- cross section	Opis Description	Materijal Material	Napomena Remark
328.002		<ul style="list-style-type: none"> <li>- Brtva prema staklu /vanjska/</li> <li>- Stara oznaka 210.001.140 (Z111)</li> <li>- Gasket to the glass /exterior/</li> <li>- Former code 210.001.140 (Z111)</li> </ul>	EPDM	
328.003		<ul style="list-style-type: none"> <li>- Brtva prema staklu /vanjska/</li> <li>- Stara oznaka 210.001.142 (Z113)</li> <li>- Gasket to the glass /exterior/</li> <li>- Former code 210.001.142 (Z113)</li> </ul>	EPDM	
318.001		<ul style="list-style-type: none"> <li>- Brtva prema staklu /unutarnja/</li> <li>- Stara oznaka 210.001.125 (921)</li> <li>- Gasket to the glass /interior/</li> <li>- Former code 210.001.125 (921)</li> </ul>	EPDM	
318.002		<ul style="list-style-type: none"> <li>-Brtva prema staklu /unutarnja/</li> <li>- Stara oznaka 210.001.123 (918)</li> <li>-Gasket to the glass /interior/</li> <li>- Former code 210.001.123 (918)</li> </ul>	EPDM	
311.003		<ul style="list-style-type: none"> <li>- Brtva prema staklu /unutarnja,nosi 3-4 mm/</li> <li>- Gasket to the glass /interior, carries 3-4 mm/</li> </ul>	EPDM	
311.004		<ul style="list-style-type: none"> <li>- Brtva prema staklu /unutarnja,nosi 5-6 mm/</li> <li>- Gasket to the glass /interior,carries 5-6 mm/</li> </ul>	EPDM	

Oznaka Code	Izgled-presjek View- cross section	Opis Description	Materijal Material	Napomena Remark
311.005		<p>- Brtva prema staklu /unutarnja,nosi 7-8 mm/ - Gasket to the glass /interior,carries 7-8 mm/</p>	EPDM	

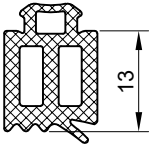
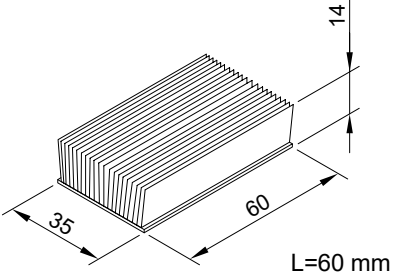
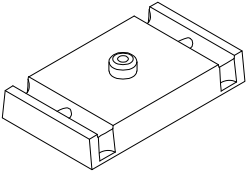
Oznaka Code	Izgled-presjek View- cross section	Opis Description	Materijal Material	Napomena Remark
348.008		- Brtva kliznog krila prema ramu - Sliding sash gasket towards frame	EPDM	
341.007		- Brtva u okomitom pojasu, na spoju dva krila - Gasket in vertical field, two sash joint	EPDM	
340.028		- Okrugla brtva Ø6 za dodatno fiksiranje pvc profila rama - Round gasket Ø6 for additional fixture pvc frame profile	EPDM	
340.029		- Okrugla brtva Ø4 za dodatno fiksiranje pvc profila rama - Round gasket Ø4 for additional fixture pvc frame profile	EPDM	
344.075		- Brtva na spoju dva krila pod 90° - Gasket on two sash joint under 90°	TPE	
344.082		- Brtva na spoju dva krila pod 90° - Gasket on two sash joint under 90°	TPE	

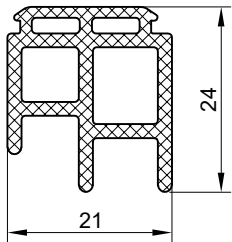
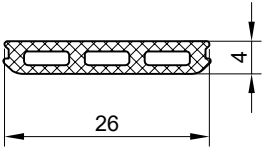
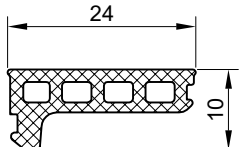
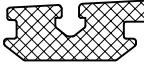
Oznaka Code	Izgled-presjek View- cross section	Opis Description	Materijal Material	Napomena Remark
358.017		- Brtva (13 mm) - Gasket (13 mm)	EPDM	
340.082		- Četkasta brtva 35x14-samoljepiva (Termo 150) - Duljina rezanja L=60 mm		
360.003		- Umetak na spoju krila (Termo 150) - Stara oznaka K-109 - Gasket on two sash joint (Termo 150) - Former code K-109		

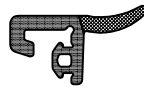
Oznaka Code	Izgled-presjek View- cross section	Opis Description	Materijal Material	Napomena Remark
348.079		- Brtva u donjem pojasu krila - Gasket in lower sash zone	EPDM	
348.061		- Brtva u pragu ispod krila - Gasket in treshold under sash	EPDM	
348.081		- Brtva u pragu na fiksnom dijelu - Treshold gasket on the fixed part	EPDM	
344.080		- Brtva ispod maske u pragu - Gasket under treshold mask	TPE	
348.067		- Brtva gornjeg vodoravnog pojasa krila - Upper horizontal sash zone gasket	EPDM Coex	
348.109		- Brtva u krilu FT-1120 - Gasket in the sash FT-1120		

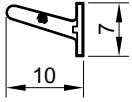
Oznaka Code	Izgled-presjek View- cross section	Opis Description	Materijal Material	Napomena Remark
327.003		- Brtva u profilu krila FT-1120, FT-1022 i FT-1020 - Gasket in the sash FT-1120, FT-1022 i FT-1020	EPDM Coex	
344.073		- Brtva na spoju krila - Sash joint gasket	TPE	
347.011		- Brtva 7x7, (crna) (Stara oznaka: QL 6970) - Oznaka proizvođača Schlegel: 2Q693223 - Seal 7x7, (black) (Former code: QL 6970) - Manufacturer code Schlegel: 2Q693223		
347.012		- Brtva 7x10, (crna) (Stara oznaka: QL 69100) - Oznaka proizvođača Schlegel: 2Q694223 - Seal 7x10, (black) (Former code: QL 69100) - Manufacturer code Schlegel: 2Q694223  * Opcija korištenja brtve * Using a gasket (options)		
347.003		- Četkasta brtva 7x9, (crna) - Oznaka proizvođača Schlegel: 2A773288016CJ - Brush seal 7x9, (black) - Manufacturer code Schlegel: 2A773288016CJ  * Opcija korištenja brtve * Using a gasket (options)		

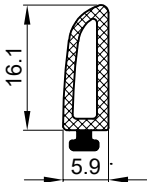
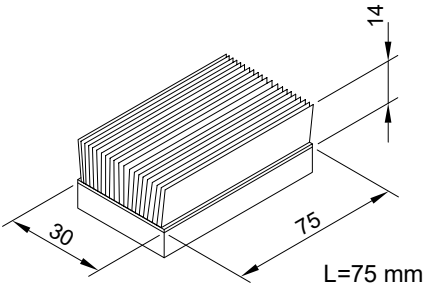
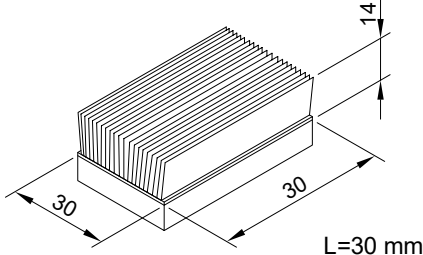
Oznaka Code	Izgled-presjek View- cross section	Opis Description	Materijal Material	Napomena Remark
344.113		-Brtva na spoju krila s krilom te krila s prečkom -Sash jonit gasket	TPE	
340.136		- Četkasta brtva 30x14-samoljepiva (Termo 150 plus) - Duljina rezanja L=75 mm - Brush gasket 30x14 - Self-adhesive (Termo 150 plus) - Cut lenght L=75 mm		
340.137		- Četkasta brtva 30x14-samoljepiva (Termo 150 plus) - Duljina rezanja L=30 mm - Brush gasket 30x14 - Self-adhesive (Termo 150 plus) - Cut lenght L=30 mm		



# Dodaci Accessories



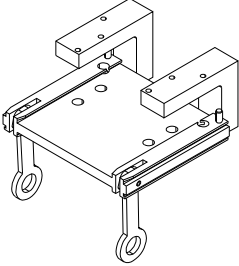
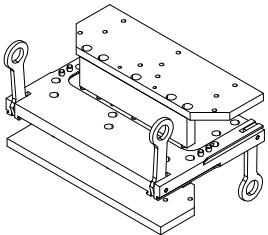
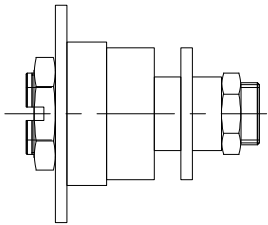
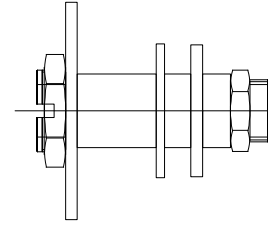
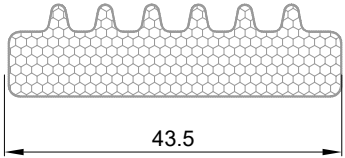
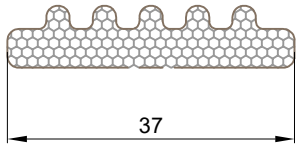

Oznaka Code	Izgled-presjek View- cross section	Opis Description	Materijal Material	Napomena Remark
433.002		Vijak 3.5x9.5 DIN 7981 Screw 3.5x9.5 DIN 7981		
433.003		Vijak 3.5x13 DIN 7981 Screw 3.5x13 DIN 7981		
433.004		Vijak 3.5x16 DIN 7981 Screw 3.5x16 DIN 7981		
433.005		Vijak 3.5x19 DIN 7981 Screw 3.5x19 DIN 7981		
433.006		Vijak 3.5x22 DIN 7981 Screw 3.5x22 DIN 7981		
433.009		Vijak 3.5x38 DIN 7981 Screw 3.5x38 DIN 7981		
433.010		Vijak 3.5x45 DIN 7981 Screw 3.5x45 DIN 7981		
433.016		Vijak 3.9x13 DIN 7981 Screw 3.9x13 DIN 7981		
433.020		Vijak 3.9x25 DIN 7981 Screw 3.9x25 DIN 7981		
433.021		Vijak 3.9x32 DIN 7981 Screw 3.9x32 DIN 7981		
433.025		Vijak 3.9x60 DIN 7981 Screw 3.9x60 DIN 7981		
433.031		Vijak 4.2x22 DIN 7981 Screw 4.2x22 DIN 7981		
433.032		Vijak 4.2x25 DIN 7981 Screw 4.2x25 DIN 7981		
433.033		Vijak 4.2x32 DIN 7981 Screw 4.2x32 DIN 7981		
433.035		Vijak 4.2x38 DIN 7981 Screw 4.2x38 DIN 7981		
433.037		Vijak 4.2x50 DIN 7981 Screw 4.2x50 DIN 7981		
433.039		Vijak 4.2x70 DIN 7981 Screw 4.2x70 DIN 7981		
433.046		Vijak 4.8x32 DIN 7981 Screw 4.8x32 DIN 7981		
433.047		Vijak 4.8x38 DIN 7981 Screw 4.8x38 DIN 7981		
433.048		Vijak 4.8x45 DIN 7981 Screw 4.8x45 DIN 7981		
433.049		Vijak 4.8x50 DIN 7981 Screw 4.8x50 DIN 7981		
433.050		Vijak 4.8x60 DIN 7981 Screw 4.8x60 DIN 7981		

Oznaka Code	Izgled-presjek View- cross section	Opis Description	Materijal Material	Napomena Remark	
433.090		Vijak 3.5x9.5 DIN 7982 Screw 4.8x50 DIN 7981			
433.091		Vijak 3.5x13 DIN 7982 Screw 3.5x13 DIN 7982			
433.093		Vijak 3.5x19 DIN 7982 Screw 3.5x19 DIN 7982			
433.103		Vijak 3.9x9.5 DIN 7982 Screw 3.9x9.5 DIN 7982			
433.104		Vijak 3.9x13 DIN 7982 Screw 3.9x13 DIN 7982			
433.105		Vijak 3.9x16 DIN 7982 Screw 3.9x16 DIN 7982			
433.106		Vijak 3.9x19 DIN 7982 Screw 3.9x19 DIN 7982			
433.109		Vijak 3.9x32 DIN 7982 Screw 3.9x32 DIN 7982			
433.110		Vijak 3.9x38 DIN 7982 Screw 3.9x38 DIN 7982			
433.111		Vijak 3.9x45 DIN 7982 Screw 3.9x45 DIN 7982			
433.133		Vijak 4.8x32 DIN 7982 Screw 4.8x32 DIN 7982			
433.134		Vijak 4.8x38 DIN 7982 Screw 4.8x38 DIN 7982			
433.135		Vijak 4.8x45 DIN 7982 Screw 4.8x45 DIN 7982			
433.136		Vijak 4.8x50 DIN 7982 Screw 4.8x50 DIN 7982			
433.204			Vijak za klipsanje, 4.2X18 Screw for clipping, 4.2X18		

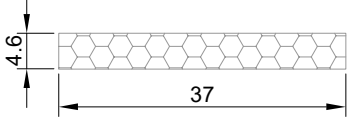
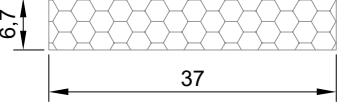
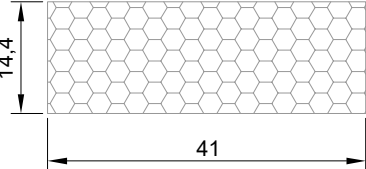
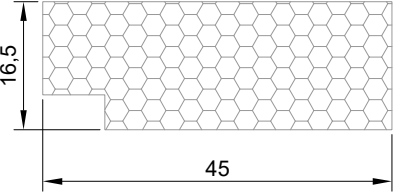
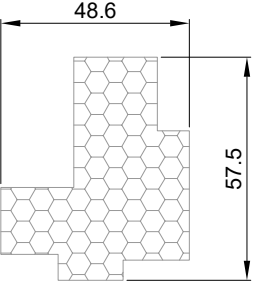
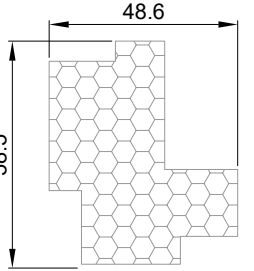
Oznaka Code	Izgled-presjek View- cross section	Opis Description	Materijal Material	Napomena Remark
230.007		-Šablon za bušenje rupa za spajanje vijcima okvira za dvostazni ram (Termo 150) -Template for drill the hole on frame for screw connection (Termo 150)	Čelik	
230.016		-Šablon za bušenje rupa za spajanje vijcima okvira za trostazni ram (Termo 150) -Template for drill the hole on frame for screw connection (Termo 150)	Čelik	
220.031		- Snop glodala za obradu profila prečke FT-1136F prema profilu FT-1102F (Termo 150 Plus) - Snop glodala za obradu profila prečke FT-1136F prema profilu FT-1102F (Termo 150 Plus)	Čelik	
220.032		- Snop glodala za obradu profila prečke FT-1136F prema profilu FT-1101F (Termo 150 Plus) - Snop glodala za obradu profila prečke FT-1136F prema profilu FT-1101F (Termo 150 Plus)	Čelik	
340.013		-Ispuna po opsegu stakla -Izoterm plamaframe -Filling around the glass -Izoterm plamaframe	PPE	
348.002		-Ispuna po opsegu stakla -Izoterm plamaframe -Filling around the glass -Izoterm plamaframe	PPE	

Oznaka Code	Izgled-presjek View- cross section	Opis Description	Materijal Material	Napomena Remark
340.020		<ul style="list-style-type: none"> <li>- Umetak u gornjem vodoravnom pojasu fiksnog krila FT-1021 prema ramu</li> <li>- Termoblok 37x4.6 za Termo 150</li> <li>- Insert in upper horizontal zone of fixed sash FT-1021 towards frame</li> <li>- Thermoblock 37x4.6 for Termo 150</li> </ul>	XPS	
340.021		<ul style="list-style-type: none"> <li>- Umetak u okomitom pojasu fiksnog krila FT-1021 prema ramu</li> <li>- Termoblok 37x6.7 za Termo 150</li> <li>- Insert in vertical zone of fixed sash FT-1021 towards frame</li> <li>- Thermoblock 37x6.7 for Termo 150</li> </ul>	XPS	
340.022		<ul style="list-style-type: none"> <li>- Umetak u gornjem vodoravnom pojasu fiksnog krila FT-1020 i FT-1022 prema ramu</li> <li>- Termoblok 41x14.4 za Termo 150</li> <li>- Insert in upper horizontal zone of fixed sash FT-1020 and FT-1022 towards frame</li> <li>- Thermoblock 41x14.4 for Termo 150</li> </ul>	XPS	
340.023		<ul style="list-style-type: none"> <li>- Umetak u donjem vodoravnom i okomitom pojasu fiksnog krila FT-1020 i FT-1022 prema ramu</li> <li>- Termoblok 45x16.5 za Termo 150</li> <li>- Insert in lower horizontal and vertical zone of fixed sash FT-1020 i FT-1022 towards frame</li> <li>- Thermoblock 45x16.5 for Termo 150</li> </ul>	XPS	
340.024	<b>M1:2</b> 	<ul style="list-style-type: none"> <li>- Umetak u okomitom pojasu krila FT-1020 na spoju dva krila-unutarnji</li> <li>- Termoblok 57.5x48.6 za Termo 150</li> <li>- Insert in vertical zone of fixed sash FT-1020 on two sash joint - inside insert</li> <li>- Thermoblock 57.5x48.6 for Termo 150</li> </ul>	XPS	
340.025	<b>M1:2</b> 	<ul style="list-style-type: none"> <li>- Umetak u okomitom pojasu krila FT-1020 na spoju dva krila-vanjski</li> <li>- Termoblok 57.5x48.6 za Termo 150</li> <li>- Insert in vertical zone of fixed sash FT-1020 on two sash joint - outside insert</li> <li>- Thermoblock 57.5x48.6 for Termo 150</li> </ul>	XPS	

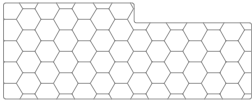
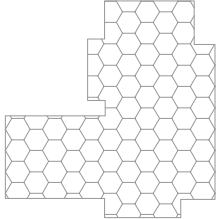
Oznaka Code	Izgled-presjek View- cross section	Opis Description	Materijal Material	Napomena Remark
340.026	<p><b>M1:2</b></p>	<ul style="list-style-type: none"> <li>- Umetak u okomitom pojasu krila FT-1021 na spoju dva krila</li> <li>- Termoblok 52.3x20 (vanjski) za Termo 150</li> <li>- Insert in vertical zone of sash FT-1021 on two sash joint</li> <li>- Thermoblock 52.3x20 (outer) for Termo 150</li> </ul>	XPS	
340.027		<ul style="list-style-type: none"> <li>- Umetak u donjem i gornjem vodoravnom i okomitom pojasu krila FT-1020</li> <li>- Termoblok 17.4x19.3 za Termo 150</li> <li>- Insert in lower and upper horizontal and vertical zone od sash FT-1020</li> <li>- Thermoblock 17.4x19.3 for Termo 150</li> </ul>	XPS	
340.050		<ul style="list-style-type: none"> <li>- Umetak u donjem i gornjem vodoravnom i okomitom pojasu krila FT-1022</li> <li>- Termoblok 21x29 za Termo 150</li> <li>- Insert in lower and upper horizontal and vertical zone od sash FT-1022</li> <li>- Thermoblock 21x29 for Termo 150</li> </ul>	XPS	
340.051	<p><b>M1:2</b></p>	<ul style="list-style-type: none"> <li>- Umetak u okomitom pojasu krila FT-1022 na spoju dva krila-vanjski</li> <li>- Termoblok 57.5x58.6 za Termo 150</li> <li>- Insert in vertical zone of sash FT-1022 on two sash joint - outer</li> <li>- Thermoblock 57.5x58.6 for Termo 150</li> </ul>	XPS	
340.052	<p><b>M1:2</b></p>	<ul style="list-style-type: none"> <li>- Umetak u okomitom pojasu krila FT-1022 na spoju dva krila-unutarnji</li> <li>- Termoblok 57.5x58.6 za Termo 150</li> <li>- Insert in vertical zone of sash FT-1022 on two sash joint - inner</li> <li>- Thermoblock 57.5x58.6 for Termo 150</li> </ul>	XPS	
340.075		<ul style="list-style-type: none"> <li>- Umetak u okomitom pojasu krila FT-1020 prema FT-1030</li> <li>- Termoblok 12.7x30 za Termo 150</li> <li>- Insert in vertical zone of sash FT-1020 towards FT-1030</li> <li>- Thermoblock 12.7x30 for Termo 150</li> </ul>	XPS	

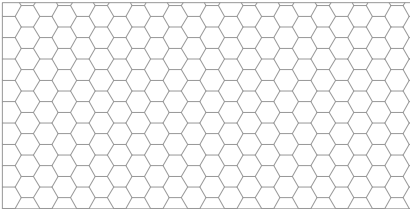
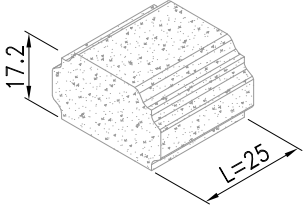
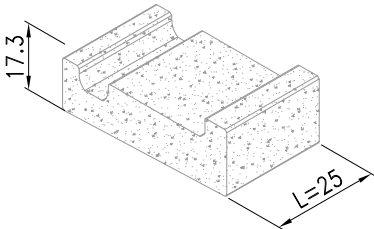
Oznaka Code	Izgled-presjek View- cross section	Opis Description	Materijal Material	Napomena Remark
340.129		- Izolacijski umetak u fiksnom dijelu - Insulation insert in the fixed part	XPS	
340.130		- Izolacijski umetak ispod maske na velikom krilu - Insulation insert under mask on the big sash	XPS	
340.131	M1:2 	- Izolacijski umetak ispod maske na malom krilu - Insulation insert under mask on the small sash	XPS	
340.132		- Izolacijski umetak ispod maske F-1539 - Insulation insert under mask F-1539	XPS	
340.454		- XPS barijera za profil FT-1102F - XPS barrier for profile FT-1102F	XPS	
340.455		- XPS barijera za profil FT-1102F - XPS barrier for profile FT-1102F	XPS	

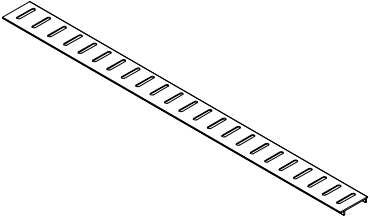
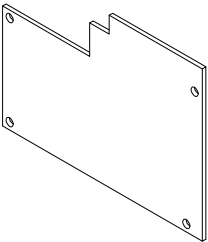
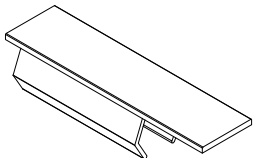
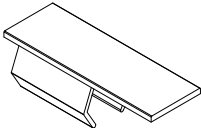
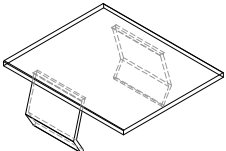
Oznaka Code	Izgled-presjek View- cross section	Opis Description	Materijal Material	Napomena Remark
521.546		- Predobrađena maska za drenažnu kadu - Prefabricated mask drainage	Al	
521.209		- Bočni čep za kadice - Side drainage profile	AL	
521.287		- Umetak za profile ojačanja (NP-4183 i NP-4184) - Reinforcement cap (NP-4183 i NP-4184)		
521.288		- Umetak za profile ojačanja (F-1634 i NP-4184) - Reinforcement cap (F-1634 i NP-4184)		
521.491		- Umetak za profile ojačanja (al.profil 50x40) - Reinforcement cap (al.profil 50x40)		

Oznaka Code	Izgled-presjek View- cross section	Opis Description	Materijal Material	Napomena Remark

**Obrada i montaža (Termo 150)**  
Processing and montage (Termo 150)



### OBRADA I SPAJANJE OKVIRA LIJEVIH VRATA PROCESSING AND CONNECTION OF LEFT DOOR FRAME

obrada rupa na profilu FT-1002F  
se radi šablonima tipa Feal  
processing holes on profile FT-1002F  
are made by Feal type templates

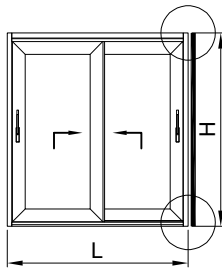

set umetaka  
za lijeva vrata  
363.043  
set of inserts  
for left door  
363.043

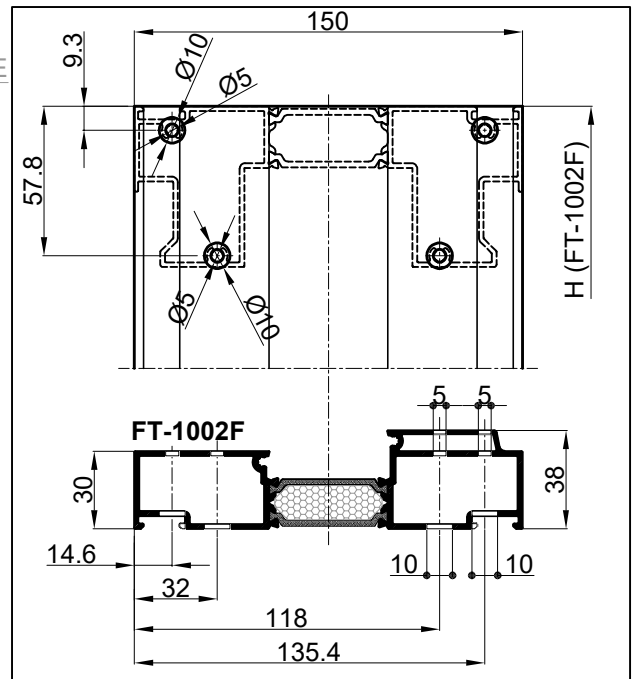
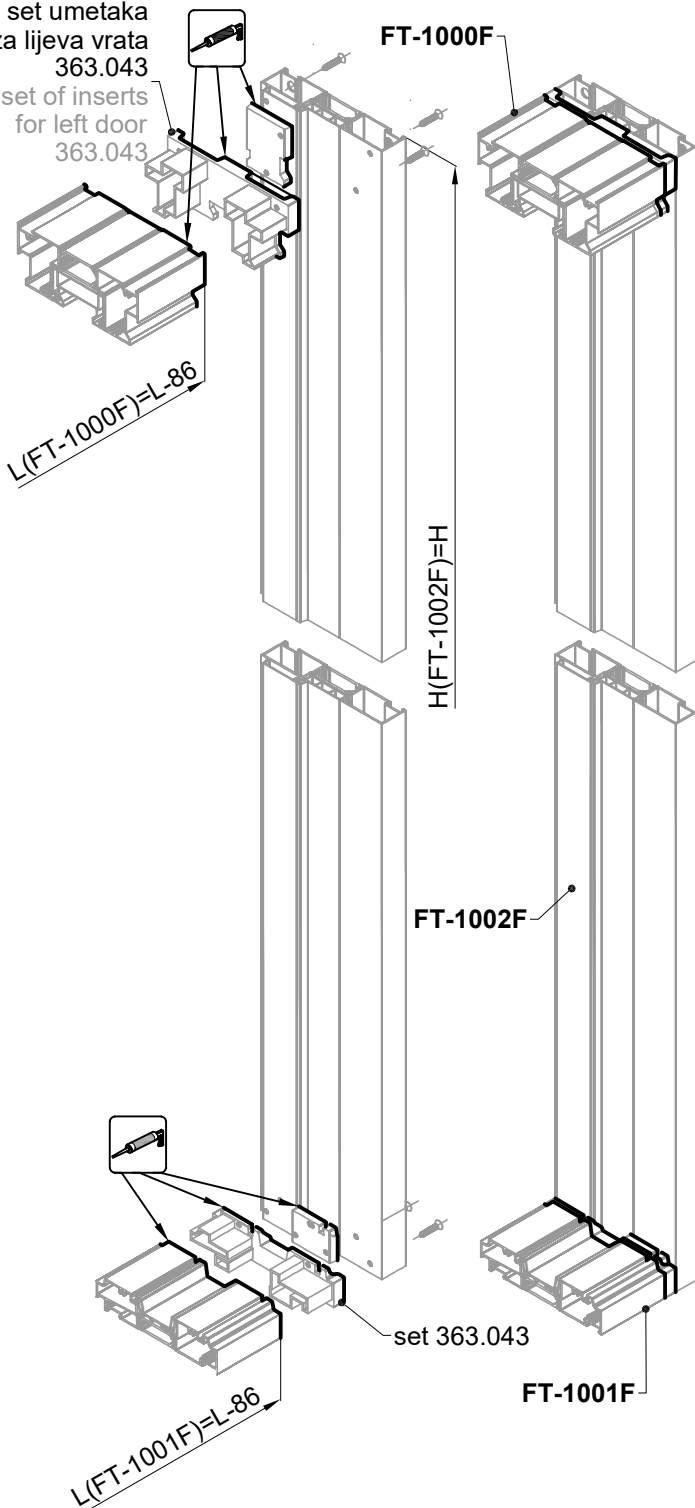

Obrada profila FT-1002F  
Processing profile FT-1002F

- profili okomice i vodoravnice okvira rama se spajaju pod 90°, vijcima 4.8x32 (DIN 7981)
- mjera pilanja vodoravnog profila  $L(FT-1000F)=L-86$
- $L(FT-1001F)=L-86$
- mjera pilanja okomitog profila  $H(FT-1002F)=H$
- profili okvira se spajaju preko pvc umetaka
- the vert. frame profile and horizontal frame profile are connected under 90° with screws 4.8x32 (DIN 7981)
- Cutting length of horizontal profile  $L(FT-1000F)=L-86$
- $L(FT-1001F)=L-86$
- Cutting length of vertical profile  $H(FT-1002F)=H$
- frame profiles are connected with pvc inserts

Obrada profila FT-1002F  
Processing profile FT-1002F

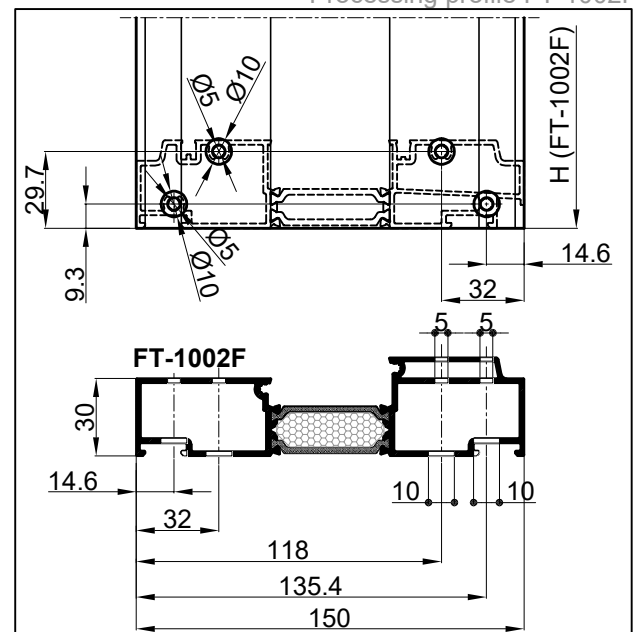

### OBRADA I SPAJANJE OKVIRA LIJEVIH VRATA PROCESSING AND CONNECTION OF LEFT DOOR FRAME

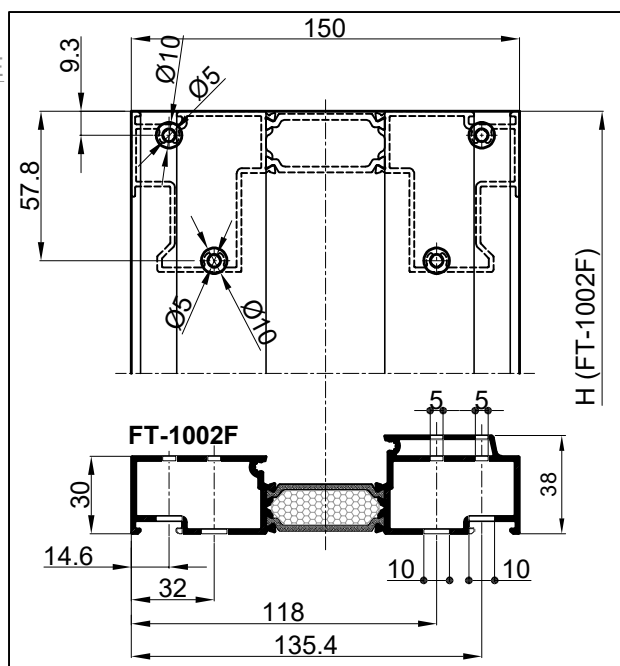
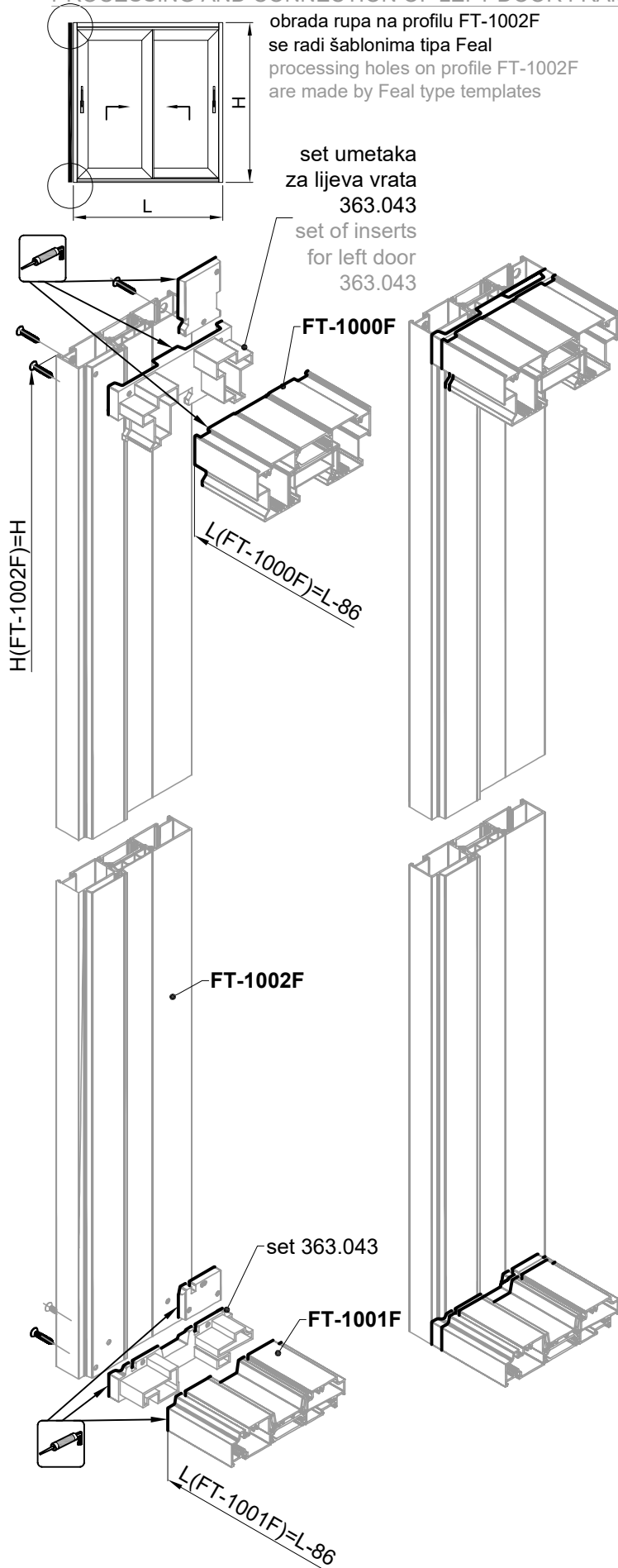

Obrada profila FT-1002F  
Processing profile FT-1002F

- profili okomice i vodoravice okvira rama se spajaju pod 90°, vijcima 4.8x32 (DIN 7981)
- mjera pilanja vodoravnog profila  
 $L(FT-1000F)=L-86$   
 $L(FT-1001F)=L-86$
- mjera pilanja okomiog profila  $H(FT-1002F)=H$
- profili okvira se spajaju preko pvc umetaka
- the vert. frame profile and the horizontal frame profile are connected under 90° with screws 4.8x32 (DIN 7981)
- Cutting length of horizontal profile  
 $L(FT-1000F)=L-86$   
 $L(FT-1001F)=L-86$
- Cutting length of vertical profile  $H(FT-1002F)=H$
- frame profiles are connected with pvc inserts

Obrada profila FT-1002F  
Processing profile FT-1002F

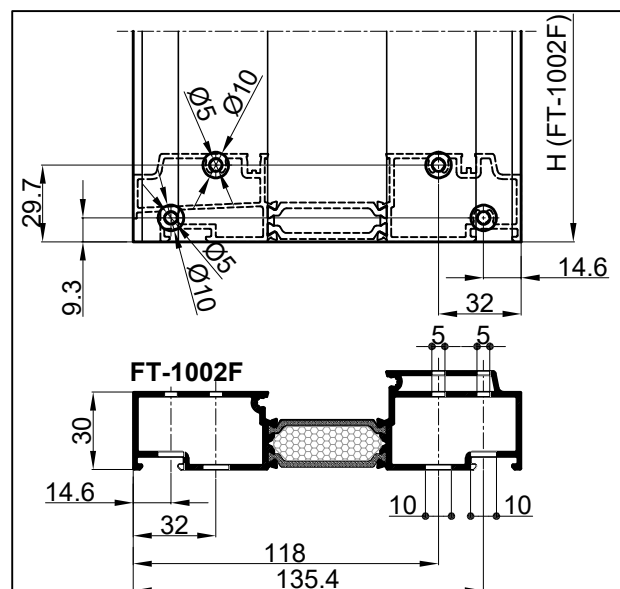

### OBRADA I SPAJANJE OKVIRA DESNIH VRATA PROCESSING AND CONNECTION OF RIGHT DOOR FRAME

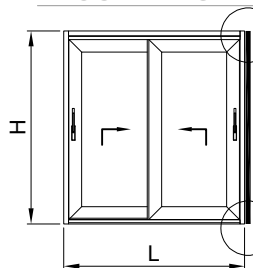

obrada rupa na profilu FT-1002F se radi šablonima tipa Feal  
processing holes on profile FT-1002F are made by Feal type templates

set umetaka za desna vrata  
set of inserts for right door

363.044

set of inserts for right door  
363.044

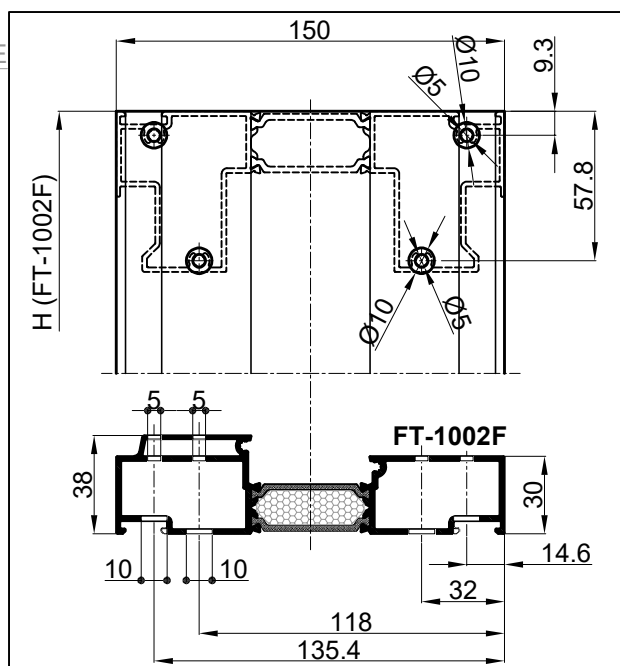
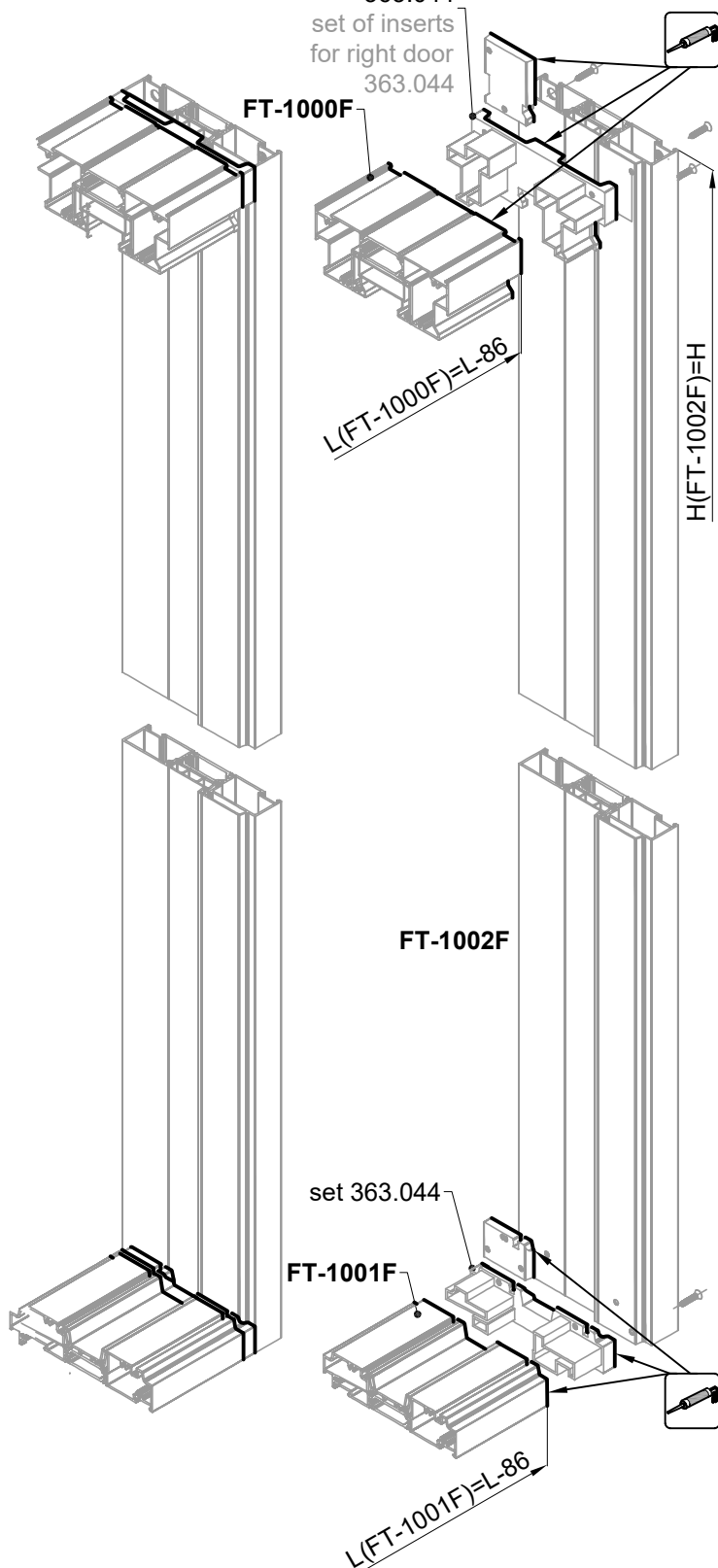

Obrada profila FT-1002F  
Processing profile FT-1002F

- profili okomice i vodoravice okvira rama se spajaju pod 90°, vijcima 4.8x32 (DIN 7981)
- mjera pilanja vodoravnog profila L (FT-1000F)=L-86
- L (FT-1001F)=L-86
- mjera pilanja okomiog profila H (FT-1002F)=H
- profili okvira se spajaju preko pvc umetaka
- the vert. frame profile and the horizontal frame profile are connected under 90° with screws 4.8x32 (DIN 7981)
- Cutting length of horizontal profile L (FT-1000F)=L-86
- L (FT-1001F)=L-86
- Cutting length of vertical profile H (FT-1002F)=H
- frame profiles are connected with pvc inserts

Obrada profila FT-1002F  
Processing profile FT-1002F

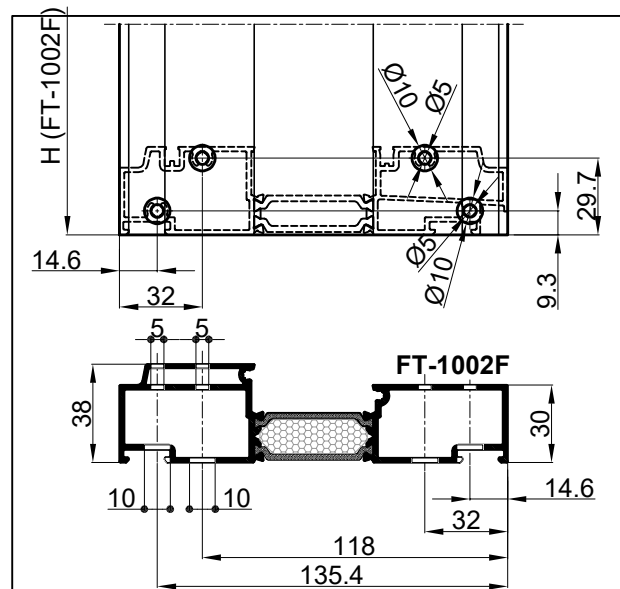

### OBRADA I SPAJANJE OKVIRA DESNIH VRATA PROCESSING AND CONNECTION OF RIGHT DOOR FRAME

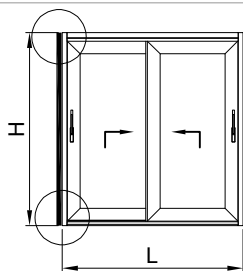

obrada rupa na profilu FT-1002F  
se radi šablonima tipa Feal  
processing holes on profile FT-1002F  
are made by feal type templates

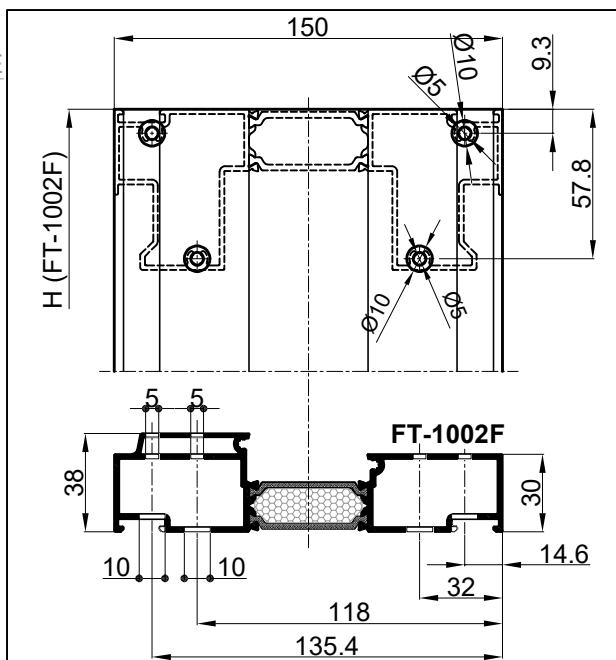

Obrada profila FT-1002F  
Processing profile FT-1002F

- profili okomice i vodoravice okvira rama se spajaju pod 90°, vijcima 4.8x32 (DIN 7981)
- mjera pilanja vodoravnog profila L (FT-1000F)=L-86
- L (FT-1001F)=L-86
- mjera pilanja okomiog profila H (FT-1002F)=H
- profili okvira se spajaju preko pvc umetaka
- the vertical frame profile and the horizontal frame profile are connected under 90° with screws 4.8x32 (DIN 7981)
- Cutting length of horizontal profile L (FT-1000F)=L-86
- L (FT-1001F)=L-86
- Cutting length of vertical profile H (FT-1002F)=H
- frame profiles are connected with pvc inserts

Obrada profila FT-1002F  
Processing profile FT-1002F

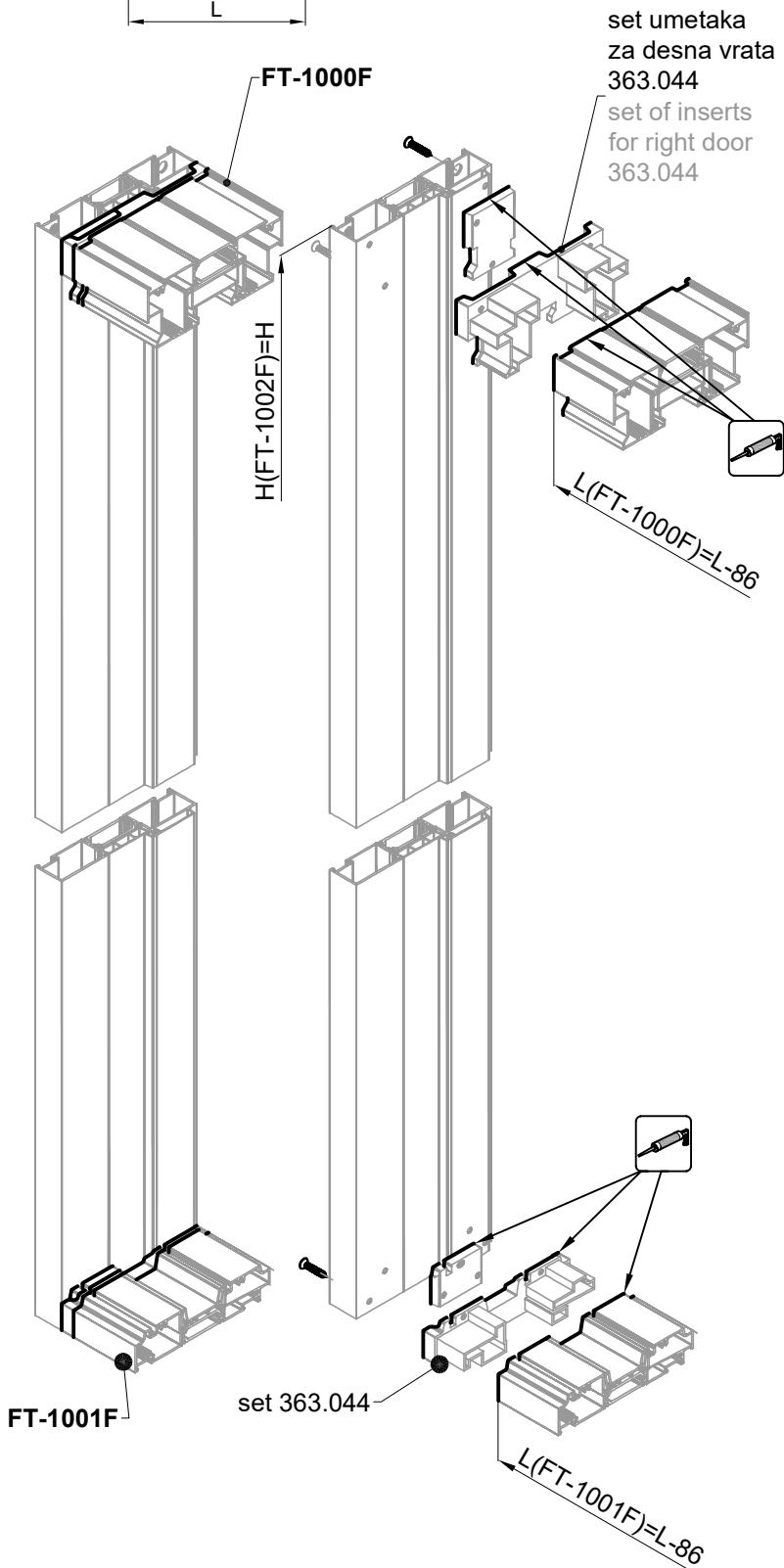
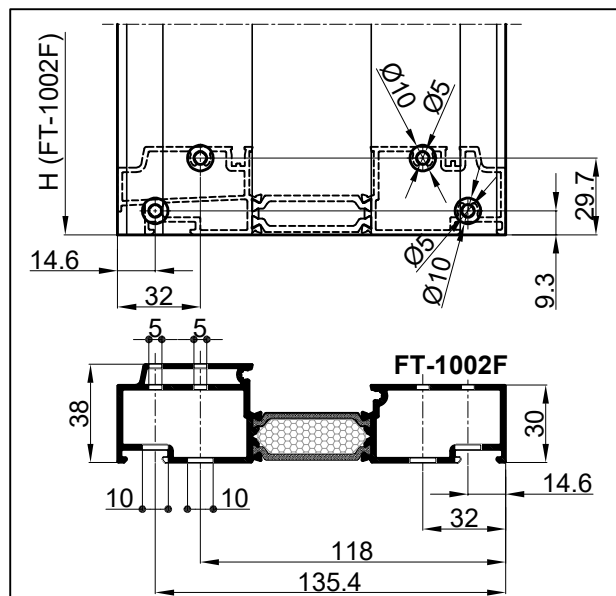

### OBRADA I SPAJANJE OKVIRA LIJEVIH VRATA PROCESSING AND CONNECTION OF LEFT DOOR FRAME

-obrada rupa na profilu FT-1005F se radi šablonima tipa Feal  
-processing holes on profile FT-1005F are made by Feal type templates

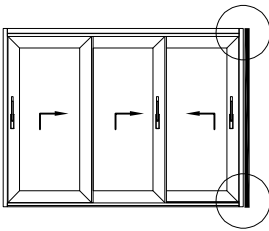

set umetaka za lijeva vrata 363.045  
set of inserts for left door 363.045

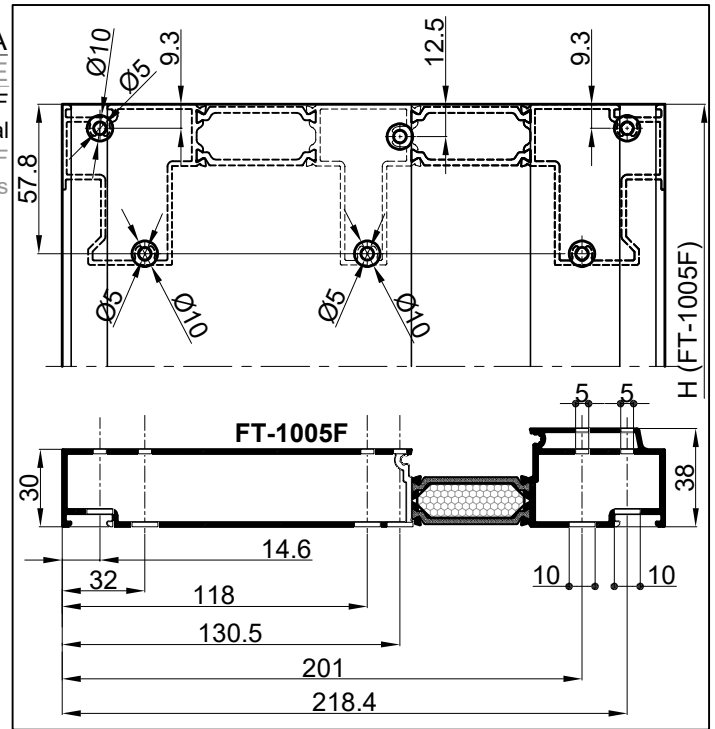
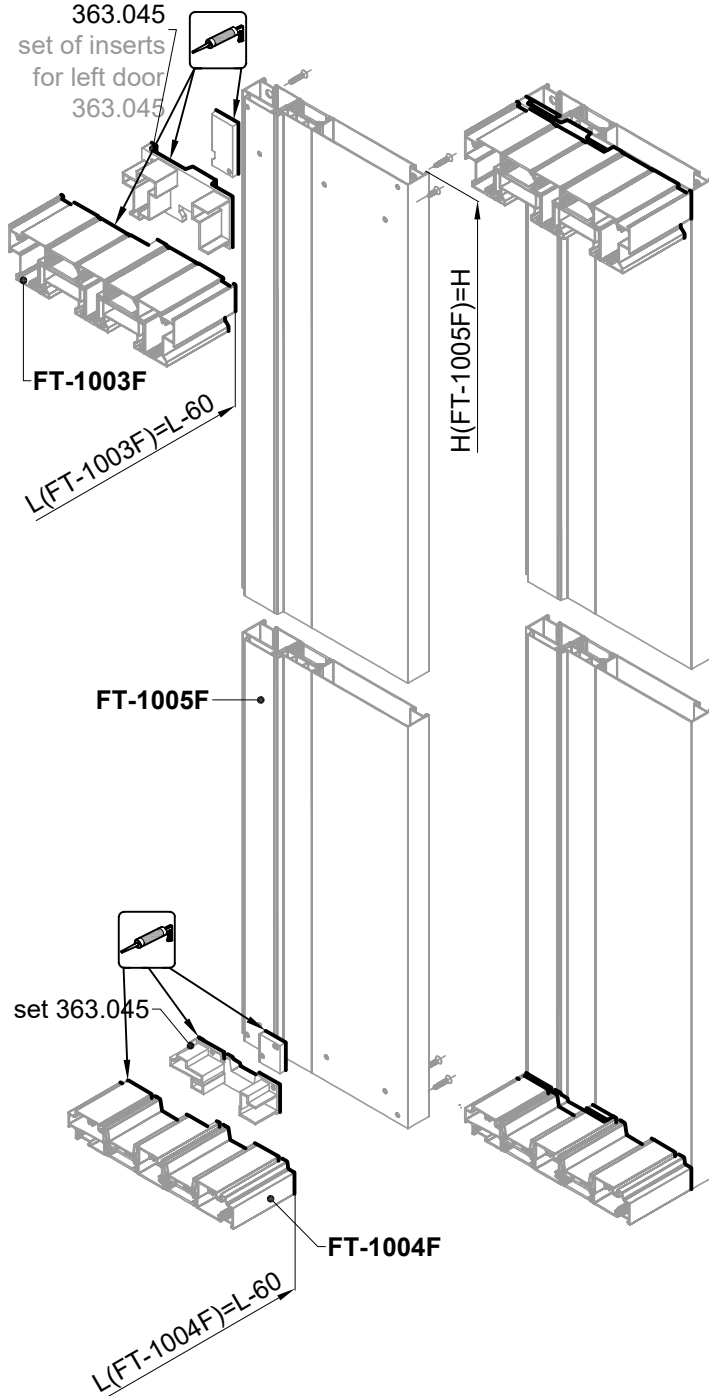

Obrada profila FT-1005F  
Processing profile FT-1005F

-profili okomice i vodoravice okvira rama se spajaju pod 90°, vijcima 4.8x32 (DIN 7981)  
-mjera pilanja vodoravnog profila  
L (FT-1003F)=L-60  
L (FT-1004F)=L-60  
-mjera pilanja okomiog profila H (FT-1005F)=H  
-profili okvira se spajaju preko pvc umetaka  
-the vert. frame profile and the horizontal frame profile are connected under 90° with screws 4.8x32 (DIN 7981)  
-Cutting length of horizontal profile  
L (FT-1003F)=L-60  
L (FT-1004F)=L-60  
-Cutting length of vertical profile H (FT-1005F)=H  
-frame profiles are connected with pvc inserts

Obrada profila FT-1005F  
Processing profile FT-1005F

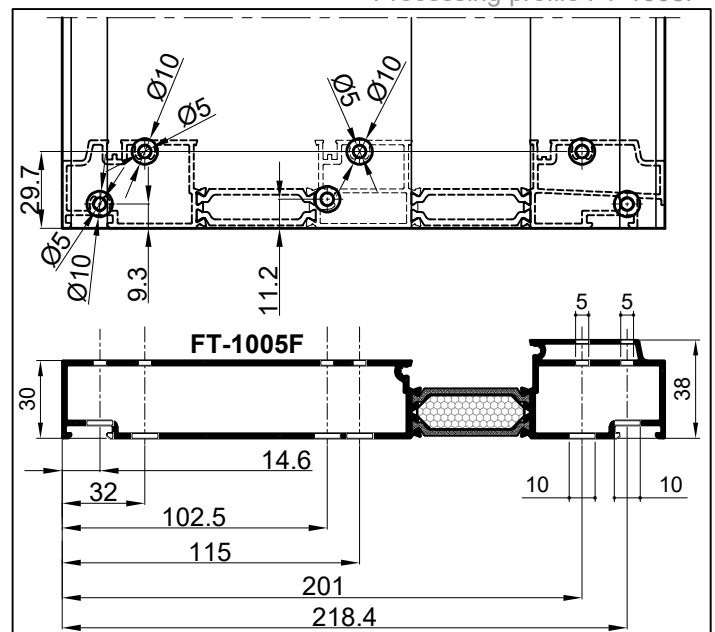

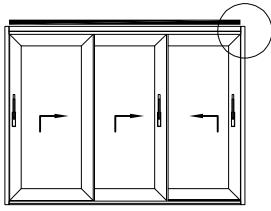

**OBRADA GORNJE VODORAVNICE OKVIRA FT-1003F I UMETKA PREMA PROFILU OKOMICE OKVIRA FT-1005F - ZA LIJEVA VRATA**  
**PROCESSING OF UPPER TRANSOM FOR FRAME FT-1003F AND INSERTS BY THE VERTICAL PROFILE OF FRAME FT-1005F - FOR LEFT DOOR**

1. Obrada profila FT-1003F  
-obrada glodanjem
1. Processing profile FT-1003F  
-milling

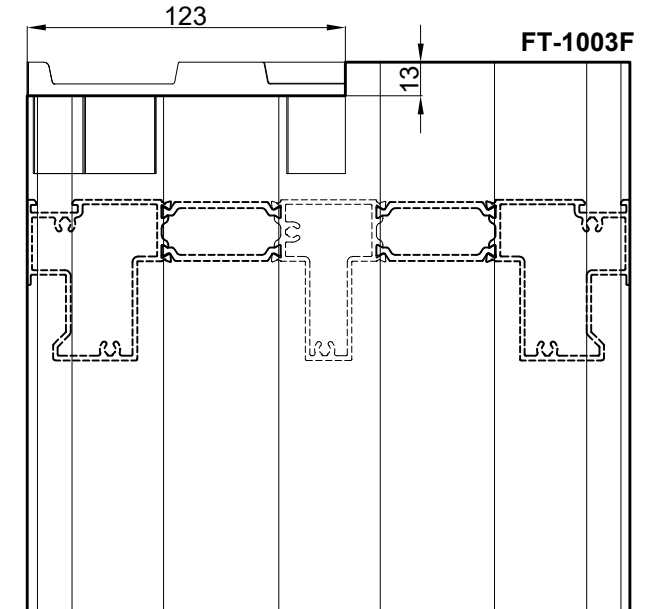
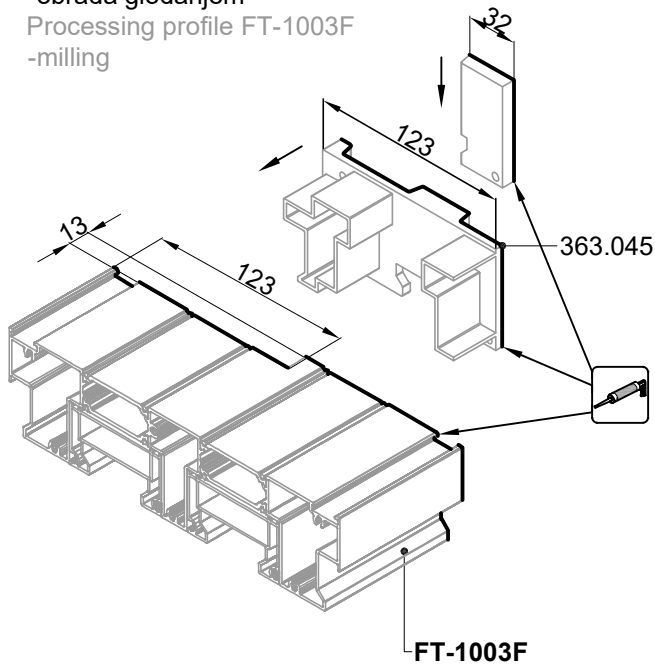

**OBRADA DONJE VODORAVNICE OKVIRA FT-1004F I UMETKA PREMA PROFILU OKOMICE OKVIRA FT-1005F - ZA LIJEVA VRATA**  
**PROCESSING OF LOWER TRANSOM FOR FRAME FT-1004F AND INSERTS BY THE VERTICAL PROFILE OF FRAME FT-1005F - FOR LEFT DOOR**

1. Obrada profila FT-1004F  
-obrada glodanjem
1. Processing profile FT-1004F  
-milling

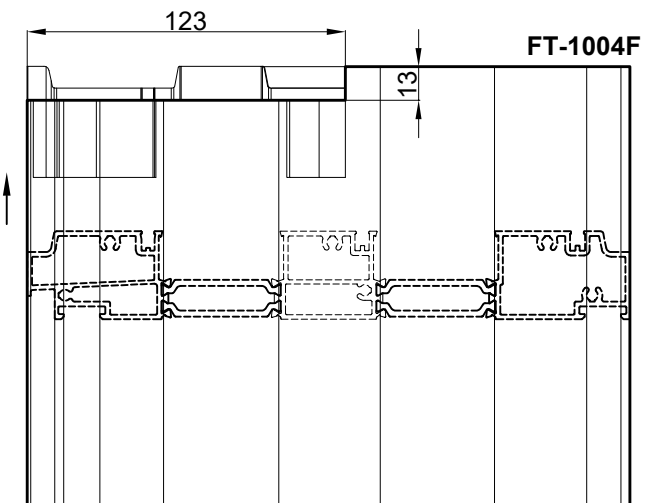
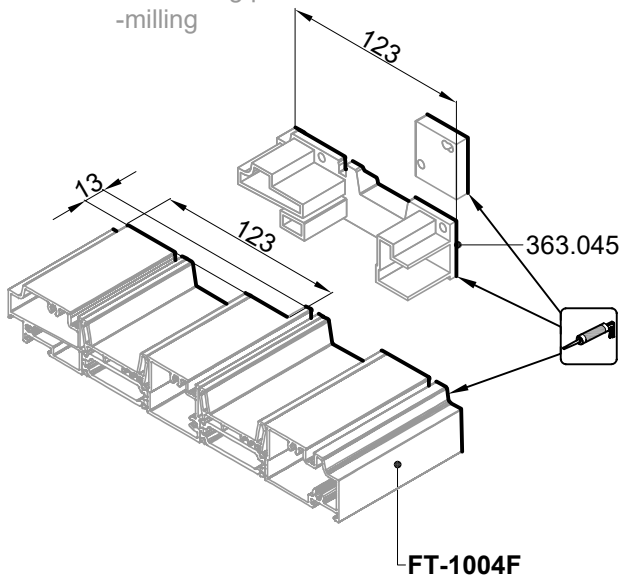
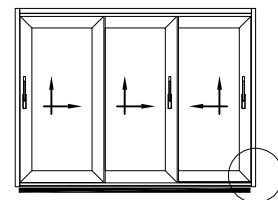

### OBRADA I SPAJANJE OKVIRA LIJEVIH VRATA PROCESSING AND CONNECTION LEFT DOOR FRAME

- obrada rupa na profilu FT-1005F se radi šablonima tipa Feal
- processing holes on profile FT-1005F are made by Feal type templates

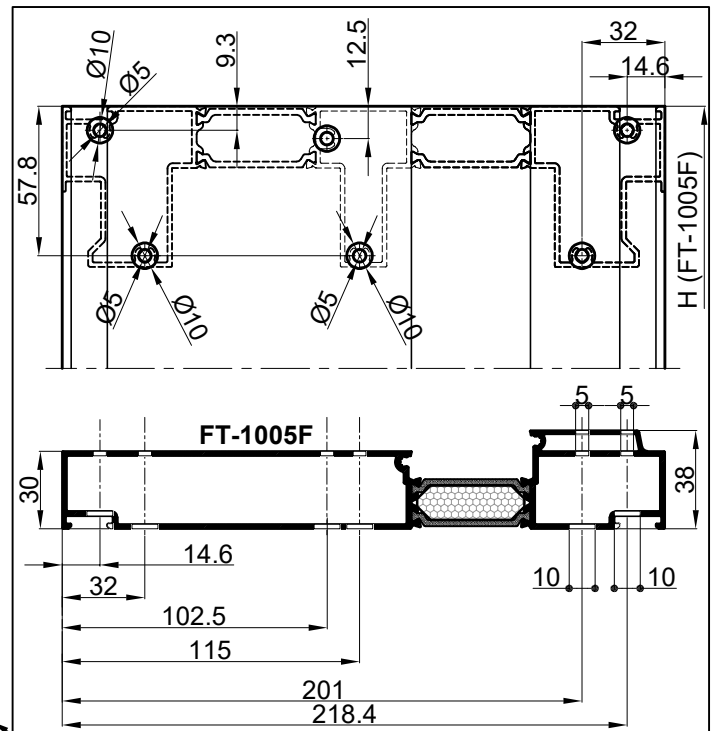
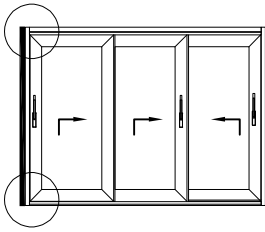

Obrada profila FT-1005F  
Processing profile FT-1005F

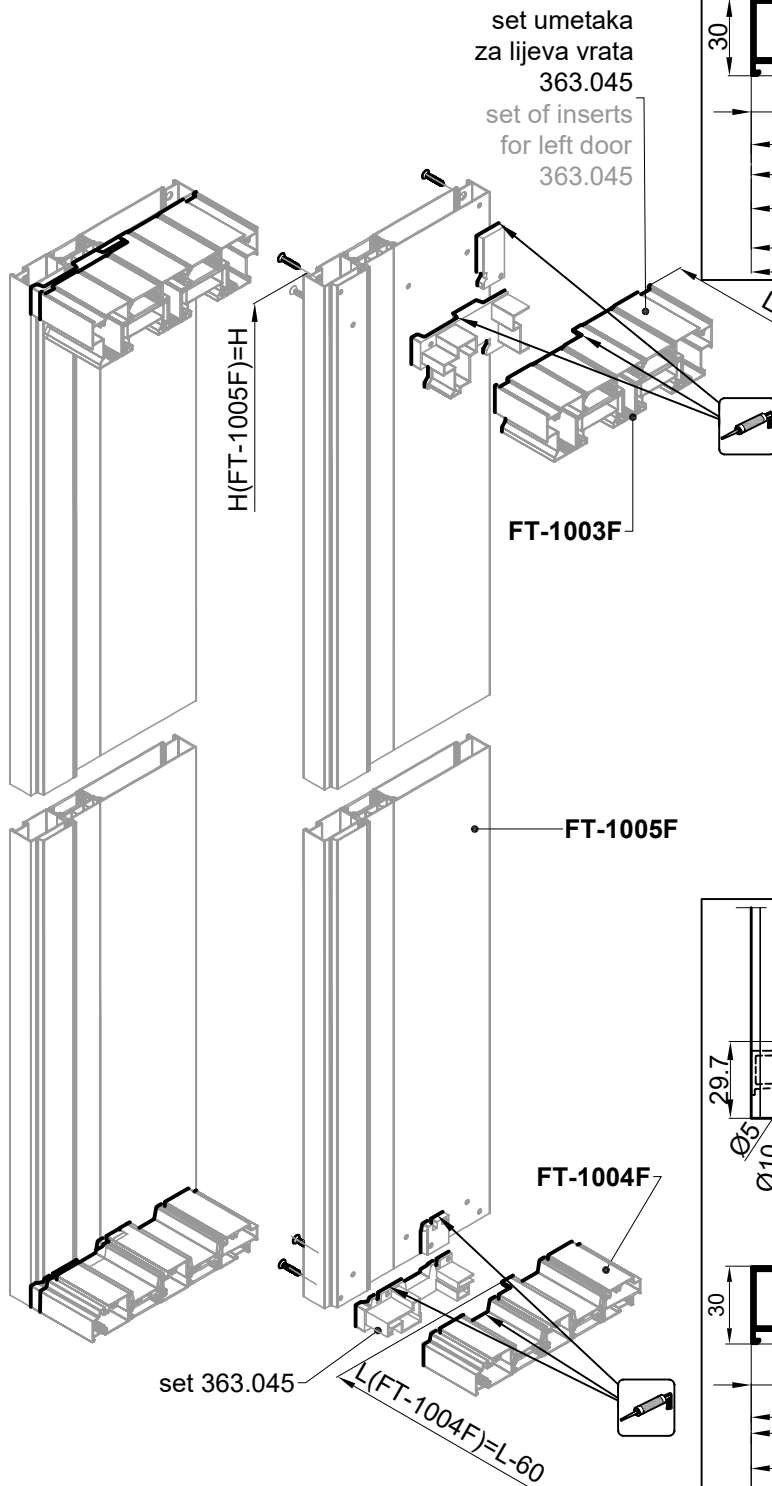

- profili okomice i vodoravnice okvira rama se spajaju pod 90°, vijcima 4.8x32 (DIN 7981)
- mjera pilanja vodoravnog profila L (FT-1003F)=L-60
- mjera pilanja okomiog profila H (FT-1005F)=H
- profili okvira se spajaju preko pvc umetaka
- the vert- frame profile and the horizontal frame profile are connected under 90° with screws 4.8x32 (DIN 7981)
- Cutting length of horizontal profile L (FT-1003F)=L-60
- Cutting length of vertical profile H (FT-1005F)=H
- frame profiles are connected with pvc inserts

Obrada profila FT-1005F  
Processing profile FT-1005F

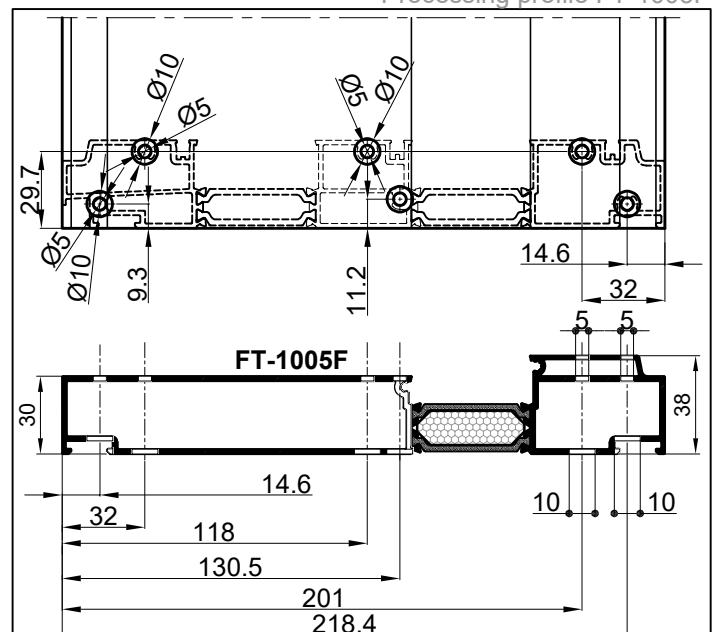

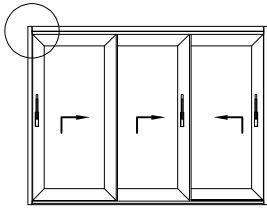

OBRADA GORNJE VODORAVNICE OKVIRA **FT-1003F** I UMETKA  
PREMA PROFILU OKOMICE OKVIRA FT-1005F - ZA LIJEVA VRATA  
PROCESSING OF UPPER TRANSOM FOR FRAME FT-1003F AND  
INSERTS BY THE VERTICAL PROFILE OF FRAME FT-1005F - FOR  
LEFT DOOR

1. Obrada profila FT-1003F  
-obrada glodanjem
1. -Processing profile FT-1003F  
-milling

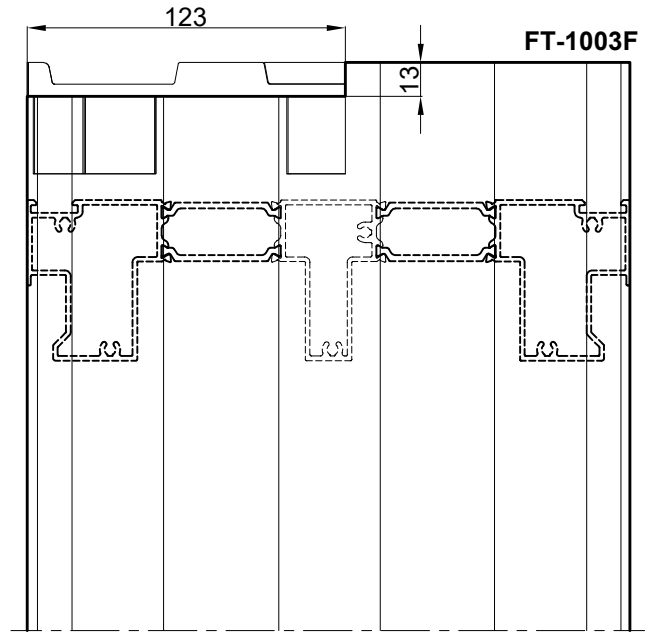
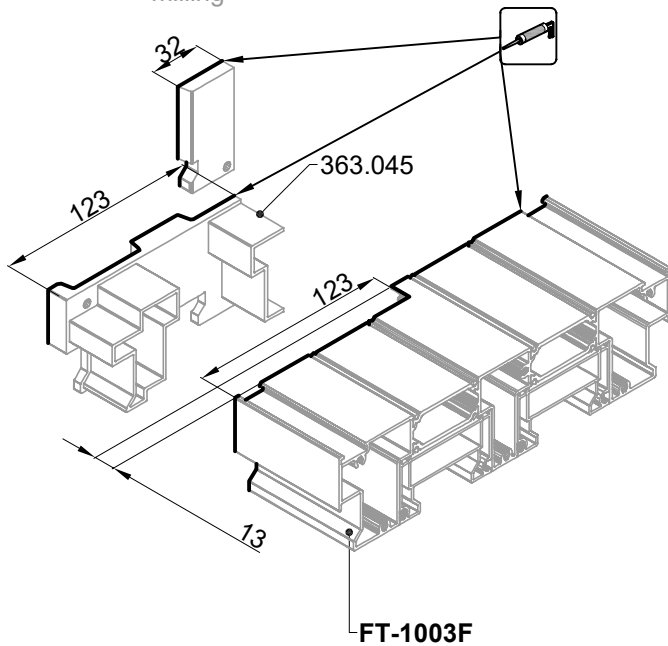

OBRADA DONJE VODORAVNICE OKVIRA **FT-1004F** I UMETKA  
PREMA PROFILU OKOMICE OKVIRA FT-1005F - ZA LIJEVA VRATA  
PROCESSING OF LOWER TRANSOM FOR FRAME FT-1004F AND  
INSERTS BY THE VERTICAL PROFILE OF FRAME FT-1005F - FOR  
LEFT DOOR

1. Obrada profila FT-1004F  
-obrada glodanjem
1. Processing profile FT-1004F  
-milling

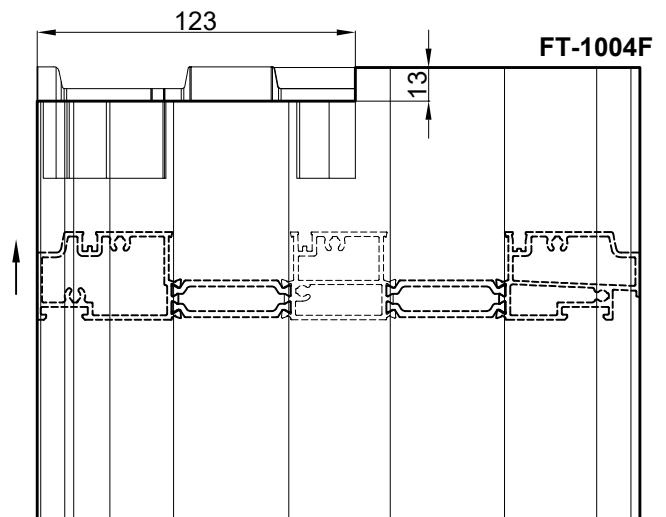
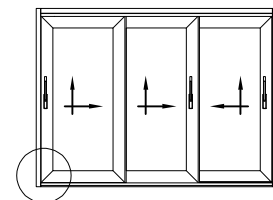
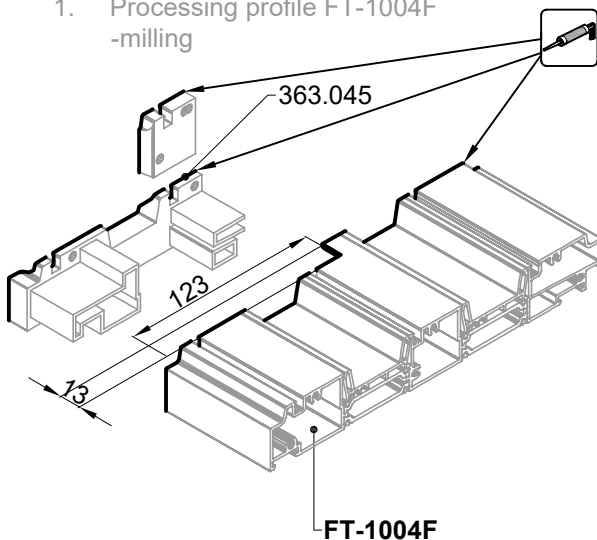

### OBRADA I SPAJANJE OKVIRA DESNIH VRATA PROCESSING AND CONNECTION OF RIGHT DOOR FRAME

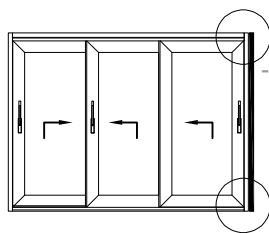

- obrada rupa na profilu FT-1005F  
se radi šablonima tipa Feal  
- processing holes on profile FT-1005F are  
made by Feal type templates

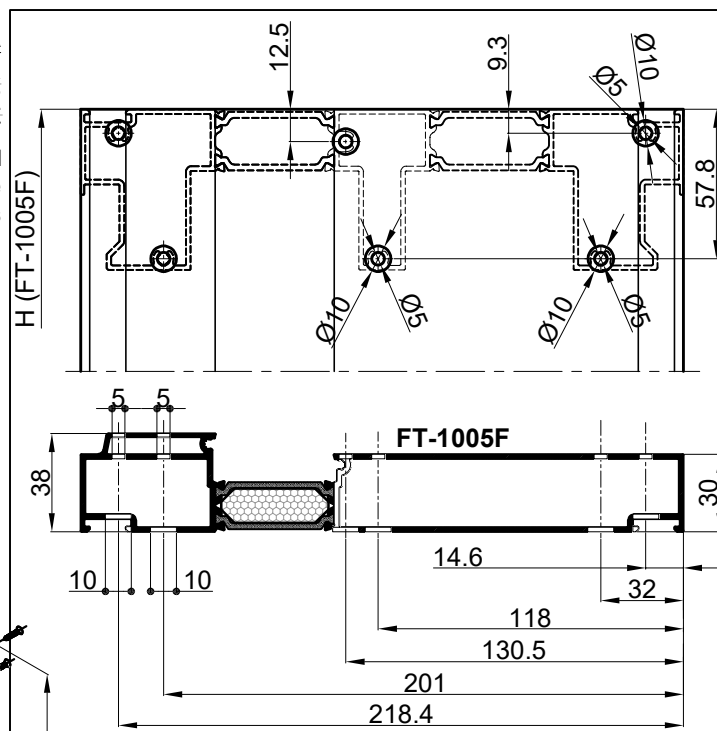
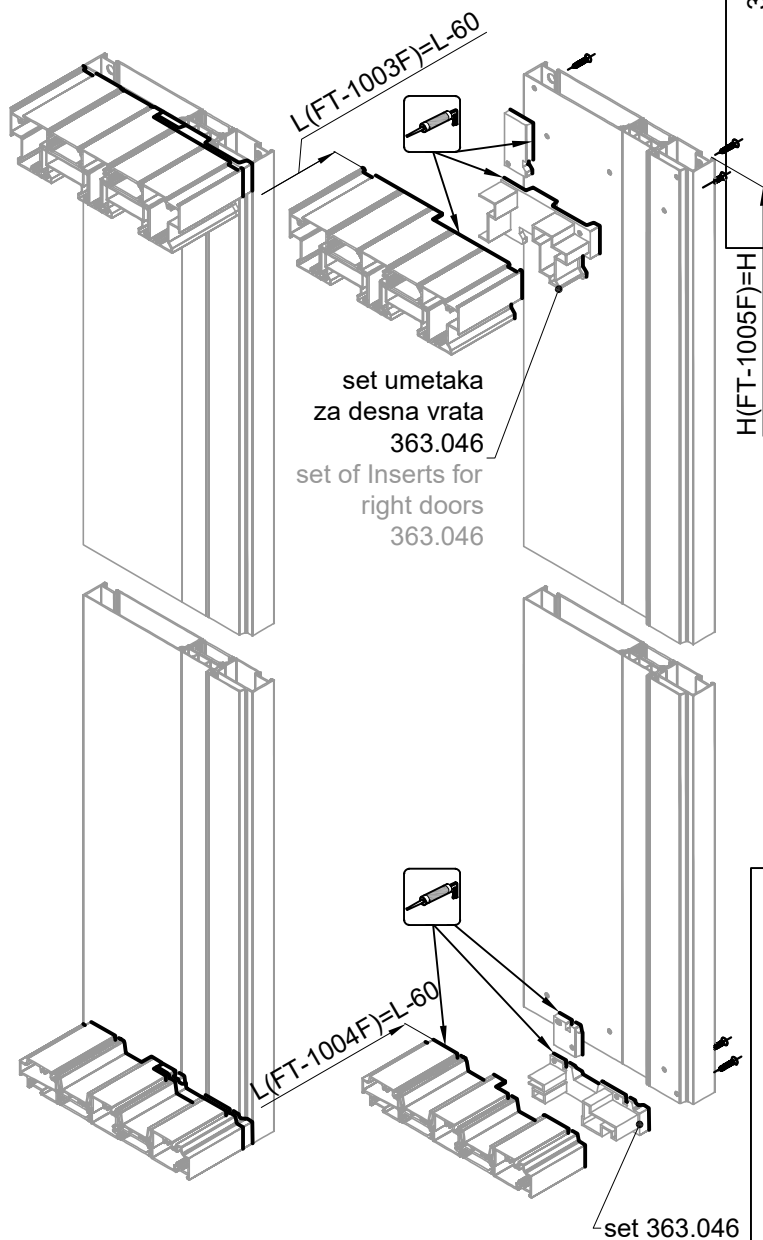

Obrada profila FT-1005F  
Processing profile FT-1005F

- profili okomice i vodoravnice okvira rama se spajaju pod 90°, vijcima 4.8x32 (DIN 7981)
- mjera pilanja vodoravnog profila  
L (FT-1003F)=L-60  
L (FT-1004F)=L-60
- mjera pilanja okomiog profila H (FT-1005F)=H
- profili okvira se spajaju preko pvc umetaka
- the vert. frame profile and horizontal frame profile are connected under 90° with screws 4.8x32 (DIN 7981)
- Cutting length of horizontal profile  
L (FT-1003F)=L-60  
L (FT-1004F)=L-60
- cutting length of vertical profile H (FT-1005F)=H
- frame profiles are connected with pvc inserts

Obrada profila FT-1005F  
Processing profile FT-1005F

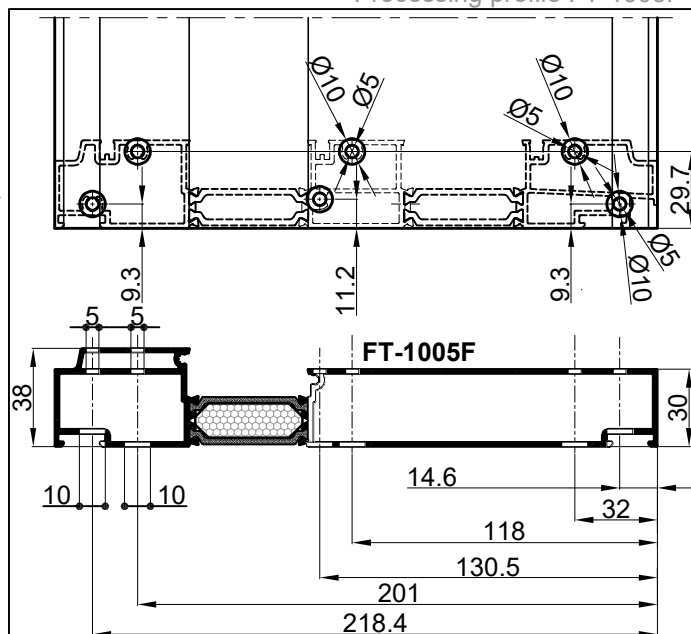

**OBRADA GORNJE VODORAVNICE OKVIRA FT-1003F I UMETKA  
PREMA PROFILU OKOMICE OKVIRA FT-1005F - ZA DESNA VRATA**  
PROCESSING OF UPPER TRANSOM OF FRAME FT-1003F AND  
INSERTS BY THE VERTICAL FRAME ON PROFILE FT-1005F - FOR  
RIGHT DOOR

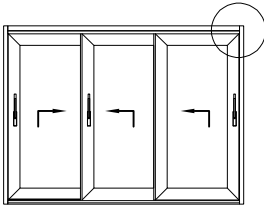

1. Obrada profila FT-1003F  
-obrada glodanjem
1. Processing profile FT-1003F  
-milling

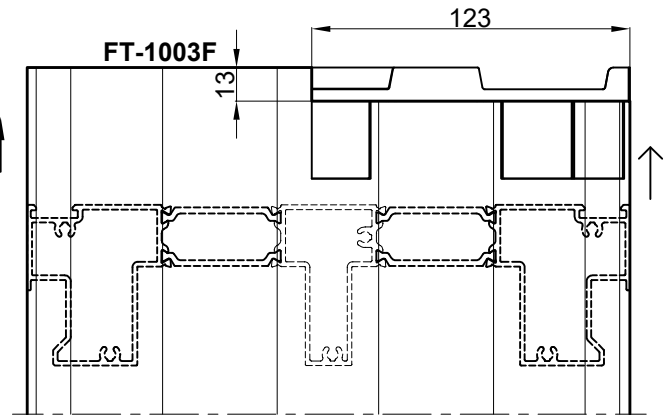
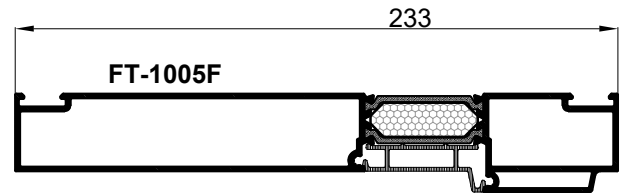
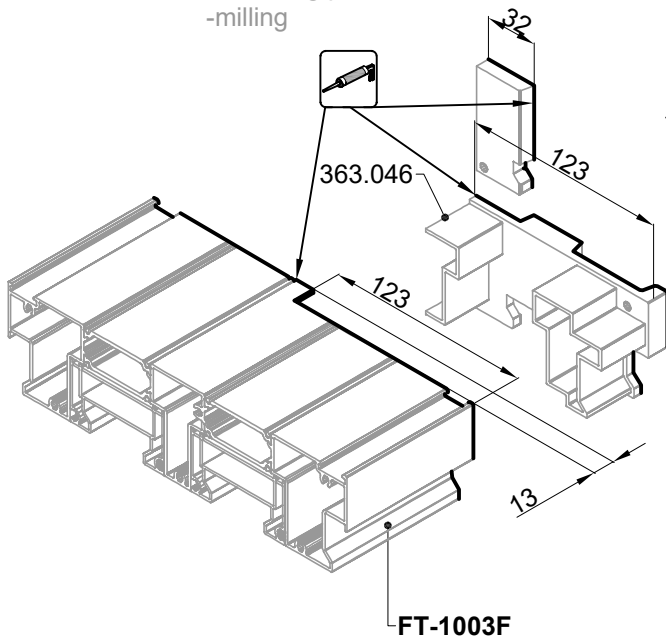

**OBRADA DONJE VODORAVNICE OKVIRA FT-1004F I UMETKA  
PREMA PROFILU OKOMICE OKVIRA FT-1005F - ZA DESNA VRATA**  
PROCESSING OF LOWER TRANSOM OF FRAME FT-1004F AND  
INSERTS BY THE VERTICAL PROFILE ON FRAME FT-1105F - FOR  
RIGHT DOOR

1. Obrada profila FT-1004F  
-obrada glodanjem
2. Processing profile FT-1004F  
-milling

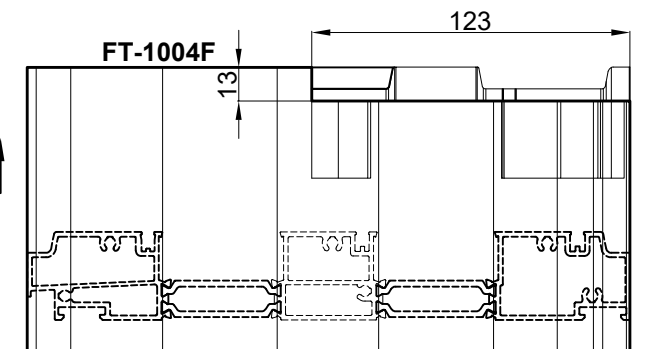
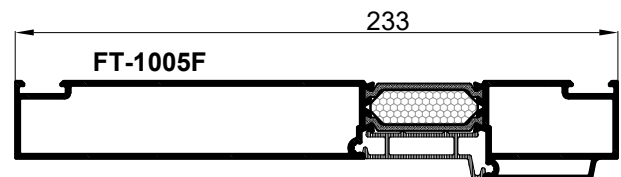
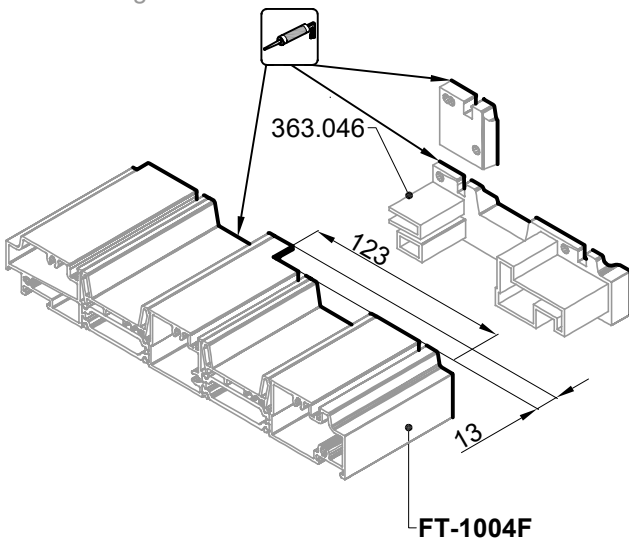
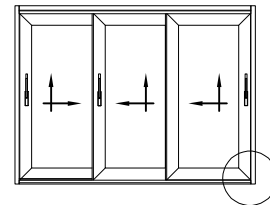

### OBRADA I SPAJANJE OKVIRA DESNIH VRATA PROCESSING AND CONNECTION OF RIGHT DOOR FRAME

-obrada rupa na profilu FT-1005F  
se radi šablonima tipa Feal  
-processing holes on profile FT-1005F  
are  
made by Feal type templates

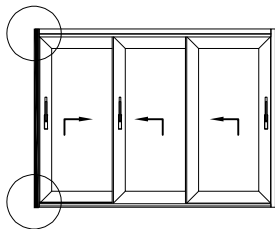

set umetaka  
za desna vrata  
363.046  
set of inserts  
for right door  
363.046

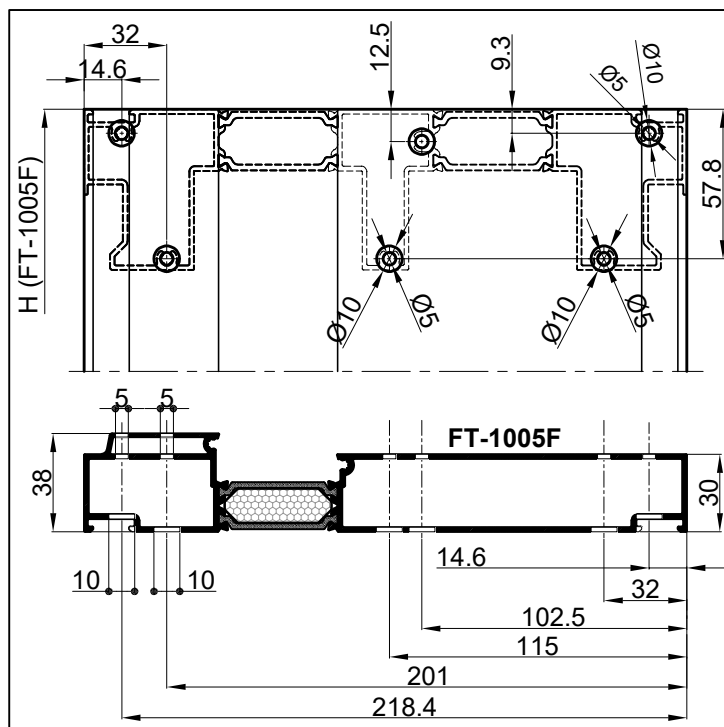
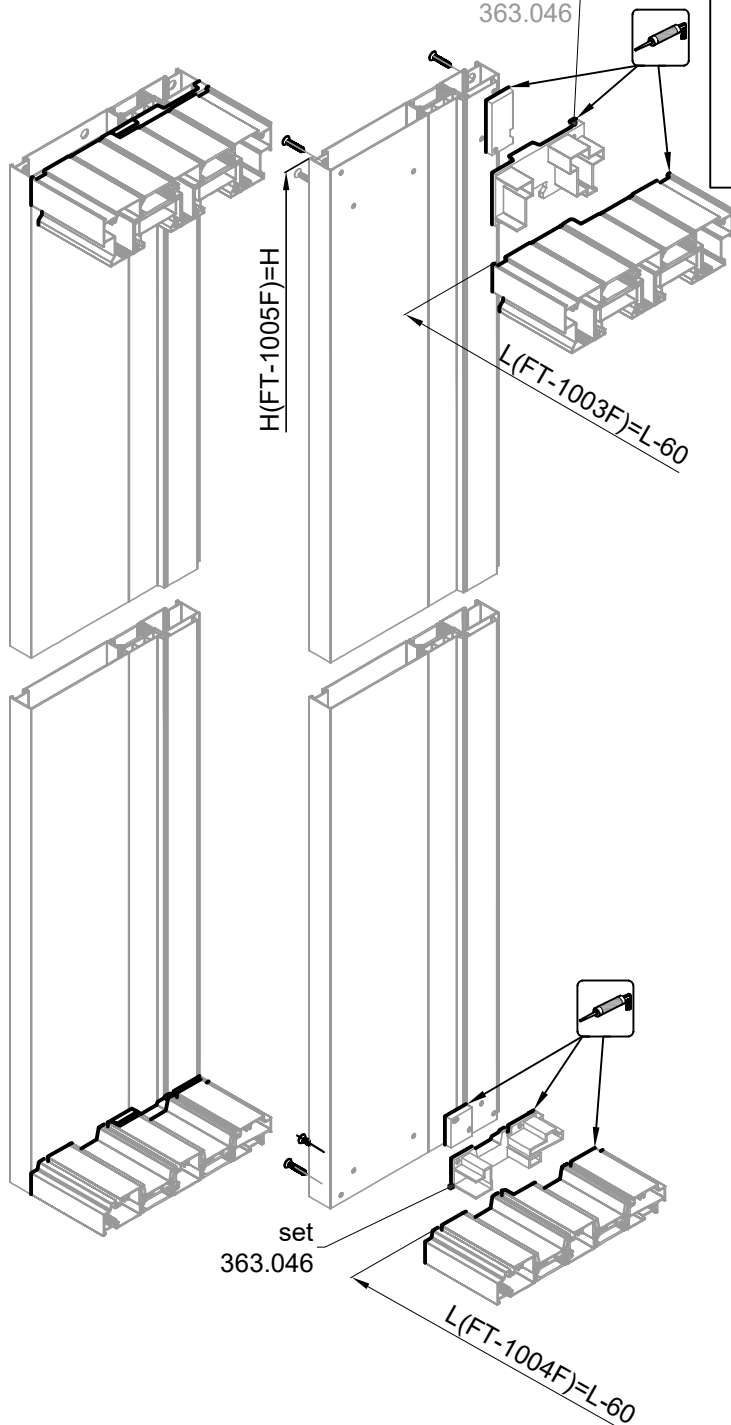

Obrada profila FT-1005F  
Processing profile FT-1005F

- profili okomice i vodoravnice okvira rama se spajaju pod 90°, vijcima 4.8x32 (DIN 7981)
- mjera pilanja vodoravnog profila  
L (FT-1003F)=L-60  
L (FT-1004F)=L-60
- mjera pilanja okomiog profila H (FT-1005F)=H
- profili okvira se spajaju preko pvc umetaka
- the vert.frame profile and horizontal frame profile are connected under 90° with screws 4.8x32 (DIN 7981)
- Cutting length of horizontal profile  
L (FT-1003F)=L-60  
L (FT-1004F)=L-60
- Cutting length of vertical profile H (FT-1005F)=H
- frame profiles are connected with pvc inserts

Obrada profila FT-1005F  
Processing profile FT-1005F

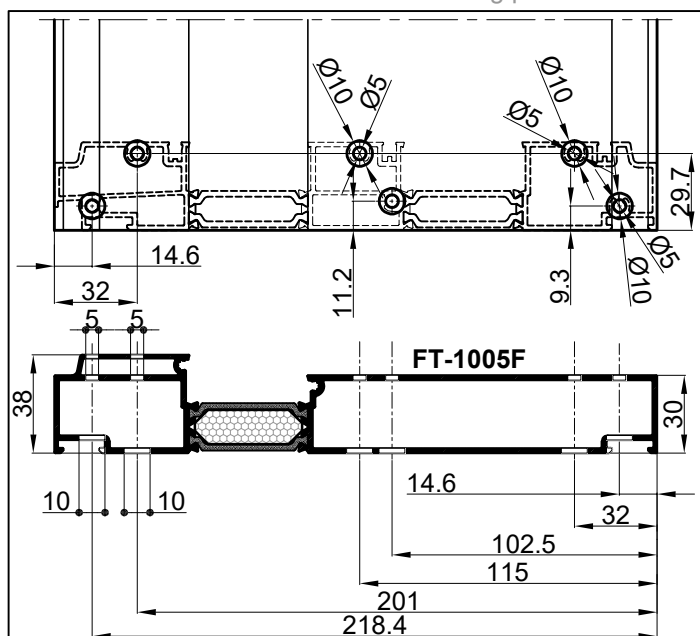

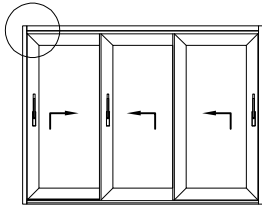

**OBRADA GORNJE VODORAVNICE OKVIRA FT-1003F I UMETKA  
PREMA PROFILU OKOMICE OKVIRA FT-1005F - ZA DESNA VRATA**  
PROCESSING OF UPPER TRANSOM OF FRAME FT-1003F AND  
INSERTS BY THE VERTICAL FRAME PROFILE FT-1005F - FOR RIGHT  
DOOR

1. Obrada profila FT-1003F  
-obrada glodanjem
2. Processing profile FT-1003F  
-milling

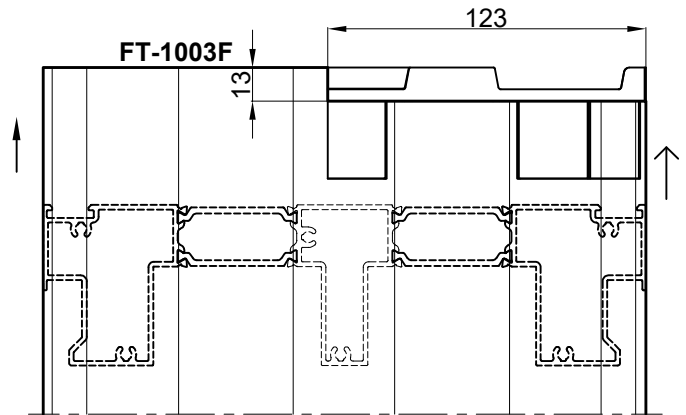
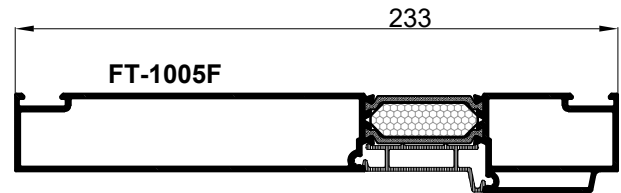
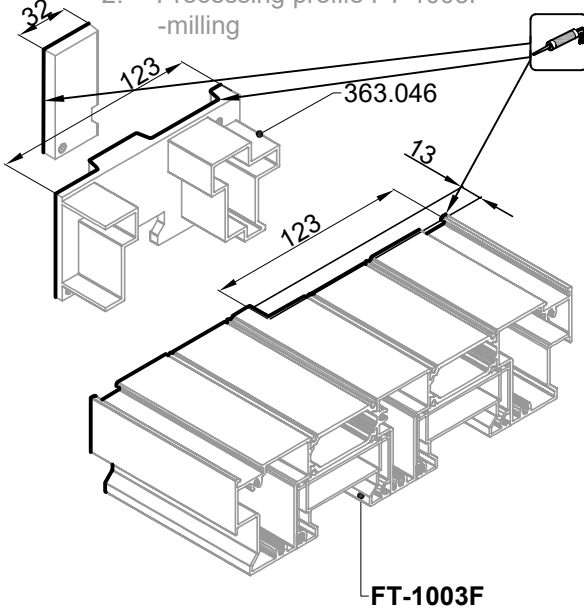

**OBRADA DONJE VODORAVNICE OKVIRA FT-1004F I UMETKA PREMA  
PROFILU OKOMICE OKVIRA FT-1005F - ZA DESNA VRATA**  
PROCESSING OF LOWER TRANSOM OF FRAME FT-1004F AND  
INSERTS BY THE VERTICAL PROFILE ON FRAME FT-1005F - FOR  
RIGHT DOOR

1. Obrada profila FT-1003F  
-obrada glodanjem
1. Processing profile FT-1003F  
-milling

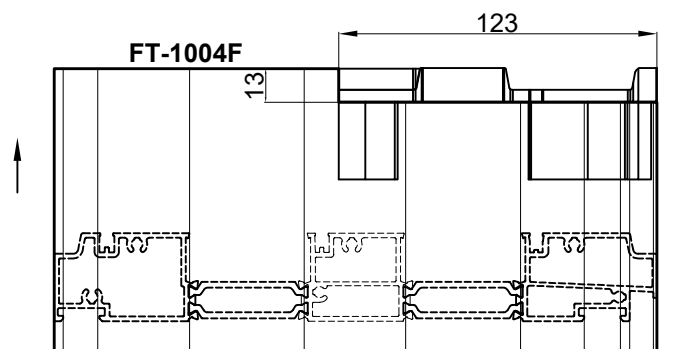
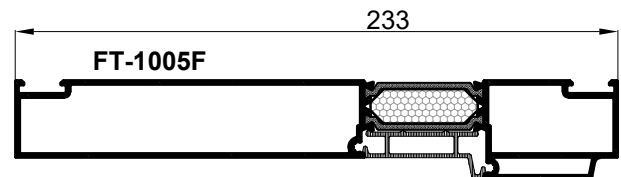
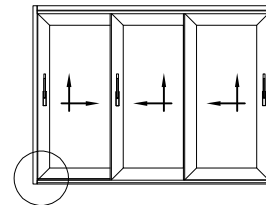
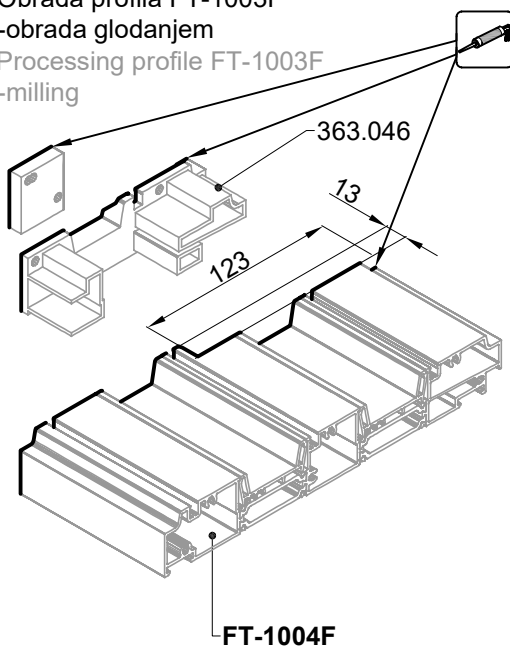

### PRESJEK C-C CROSS SECTION C-C

FT-1021F

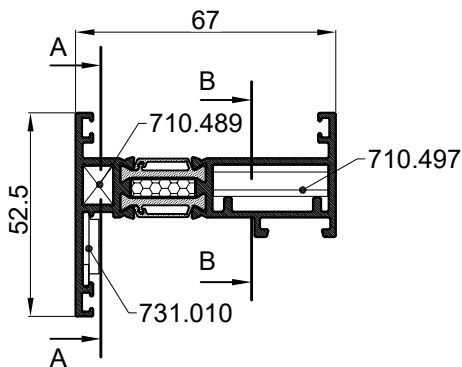

### SPAJANJE PROFILA FT-1021F KUTNICIMA CONNECTION OF PROFILE FT-1021F WITH CORNER BRACKETS

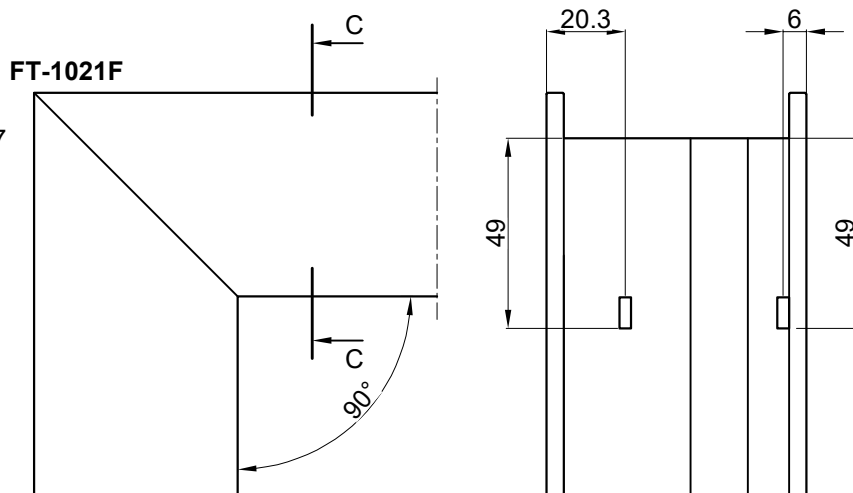

- Spajanje kutnikom **710.489** uprešavanjem stijenke profila u kutnik
- Uprešavanje izvesti kliještima art.240.001 ili strojno
- Corner bracket connection **710.489** aluminium profile corner crimping
- Corner crimping perform with pliers art.240.001 or with machine

- Spajanje kutnikom **710.497** uprešavanjem stijenke profila u kutnik
- Uprešavanje izvesti kliještima art.240.001 ili strojno
- Corner bracket connection **710.497** aluminium profile corner crimping
- Corner crimping perform with pliers art.240.001 or with machine

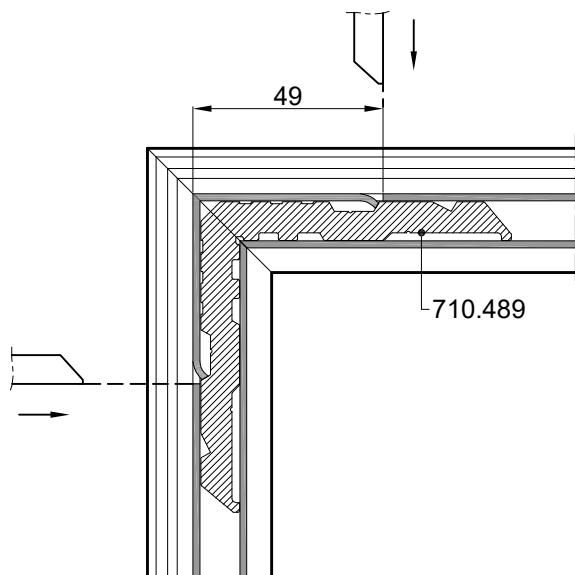

**PRESJEK A-A**  
CROSS SECTION A-A

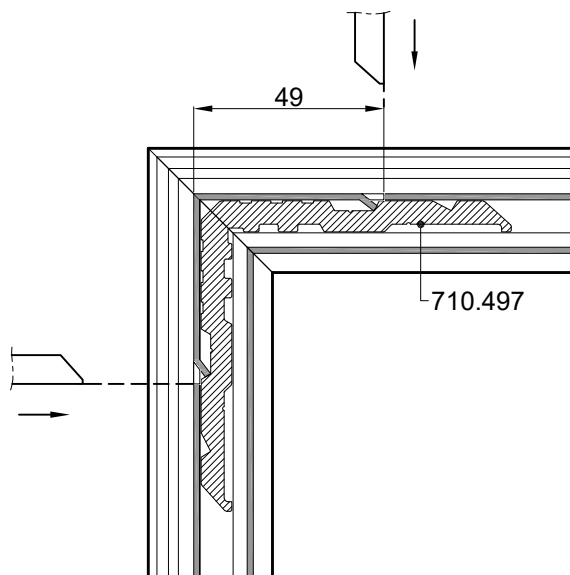

**PRESJEK B-B**  
CROSS SECTION B-B

### PRESJEK C-C CROSS SECTION C-C

FT-1021F

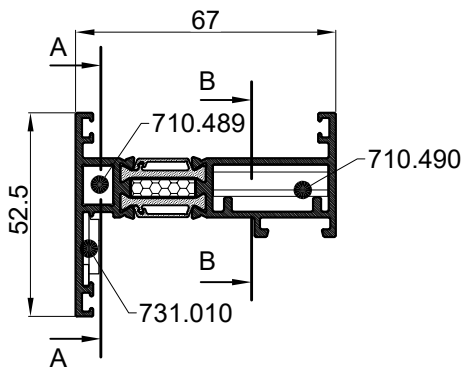

### SPAJANJE PROFILA FT-1021F KUTNICIMA CONNECTION OF PROFILE FT-1021F WITH CORNER BRACKETS

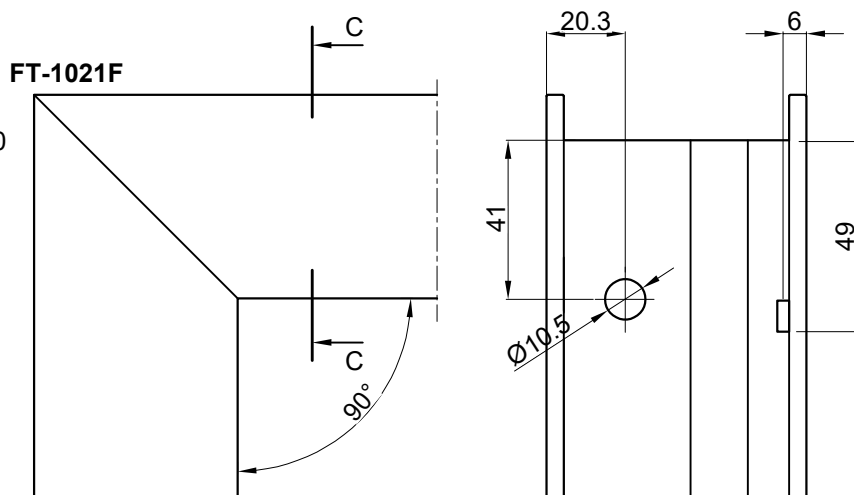

- Spajanje kutnikom **710.489** uprešavanjem stijenke profila u kutnik
- Uprešavanje izvesti kliještima art.240.001 ili strojno
- Corner bracket connection **710.489** aluminum profile corner crimping
- Corner crimping perform with pliers art.240.001 or with machine

- Spajanje kutnikom **710.490** vijcima M8x13 -*tip Feal* (431.266)
- Obrada rupe na glodalici (bušilici) vretenastim glodalom (svrdlom) Ø10.5
- Corner bracket connection **710.490** with screws M8x13 - *typ Feal* (431.266)
- Hole processing with Ø10.5 end mill

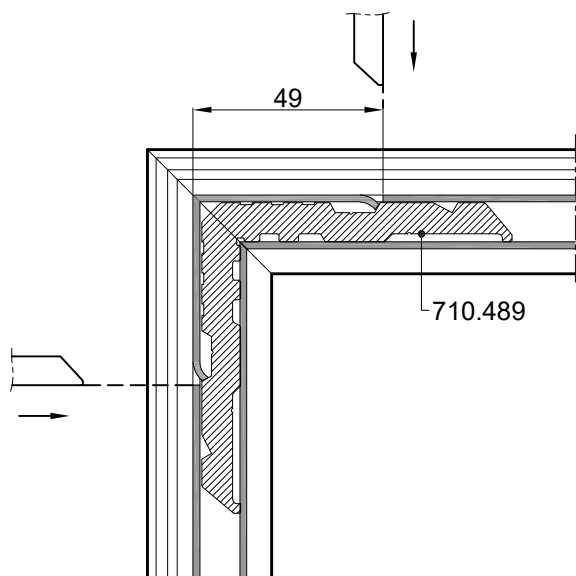

PRESJEK A-A  
CROSS SECTION A-A

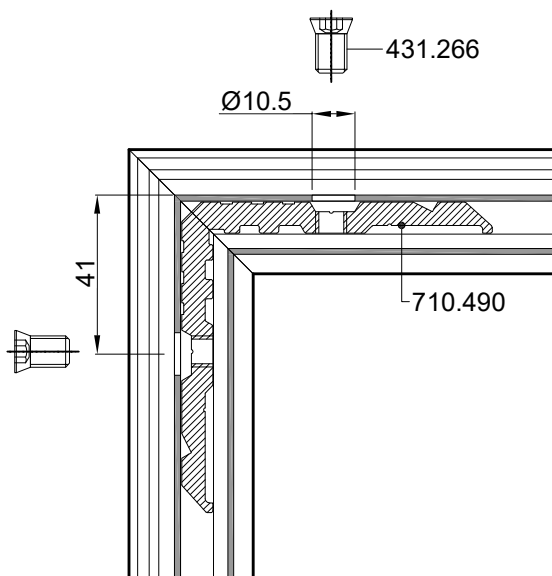

PRESJEK B-B  
CROSS SECTION B-B

### PRESJEK C-C CROSS SECTION C-C

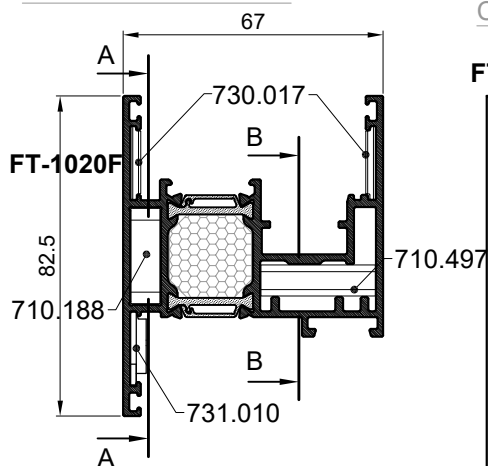

- Spajanje kutnikom **710.188** uprešavanjem stijenke profila u kutnik
- Uprešavanje izvesti kliještima art.240.001 ili strojno
- Corner bracket connection **710.188** aluminium profile corner crimping
- Corner crimping perform with pliers art.240.001 or with machine

### SPAJANJE PROFILA FT-1020F KUTNICIMA CONNECTION OF PROFILE FT-1020F WITH CORNER BRACKETS

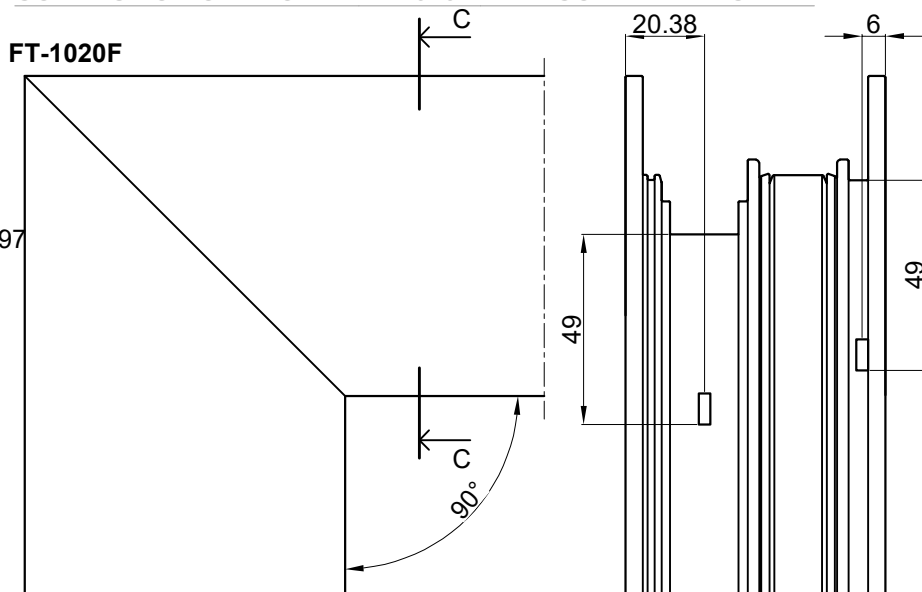

- Spajanje kutnikom **710.497** uprešavanjem stijenke profila u kutnik
- Uprešavanje izvesti kliještima art.240.001 ili strojno
- Corner bracket connection **710.497** aluminium profile corner crimping
- Corner crimping perform with pliers art.240.001 or with machine

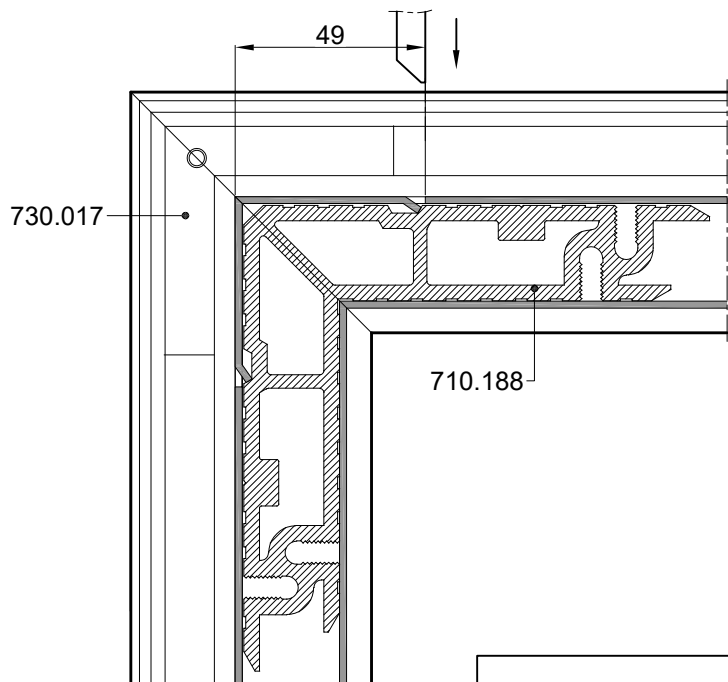

PRESJEK A-A  
CROSS SECTION A-A

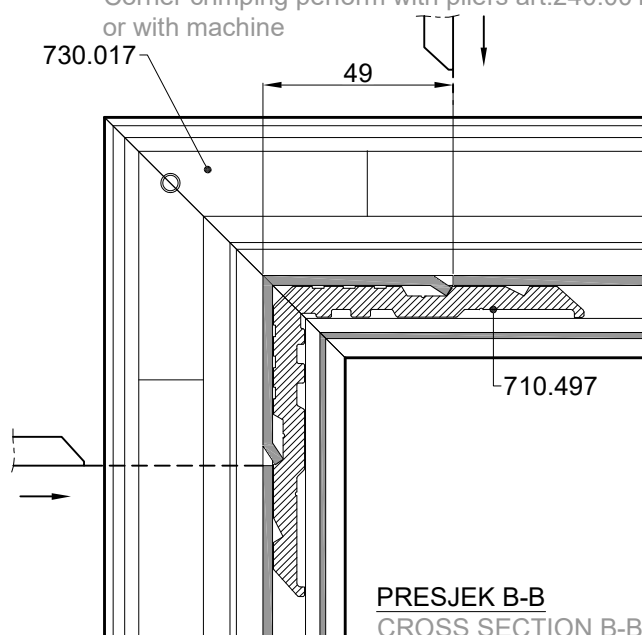

PRESJEK B-B  
CROSS SECTION B-B

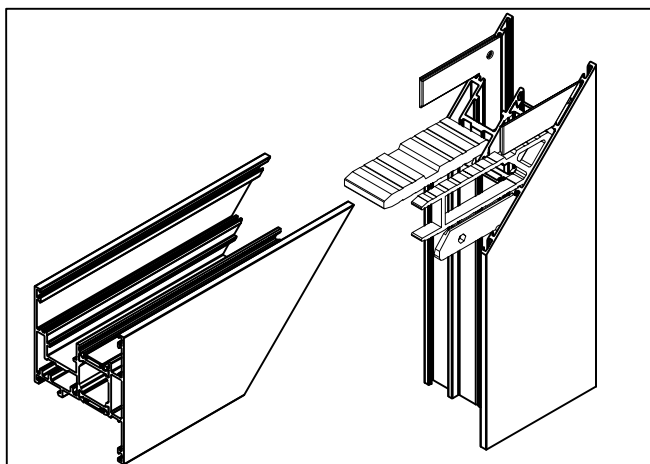

### PRESJEK C-C CROSS SECTION C-C

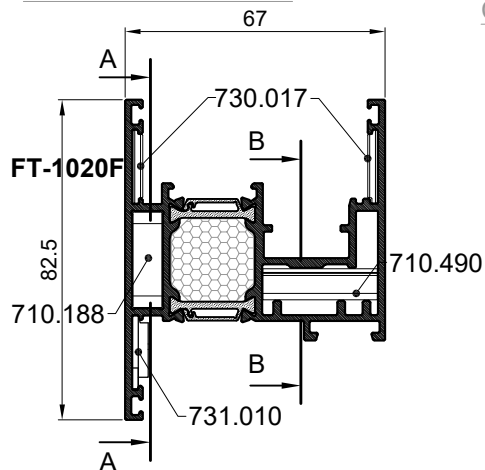

### SPAJANJE PROFILA FT-1020F KUTNICIMA CONNECTION OF PROFILE FT-1020F WITH CORNER BRACKETS

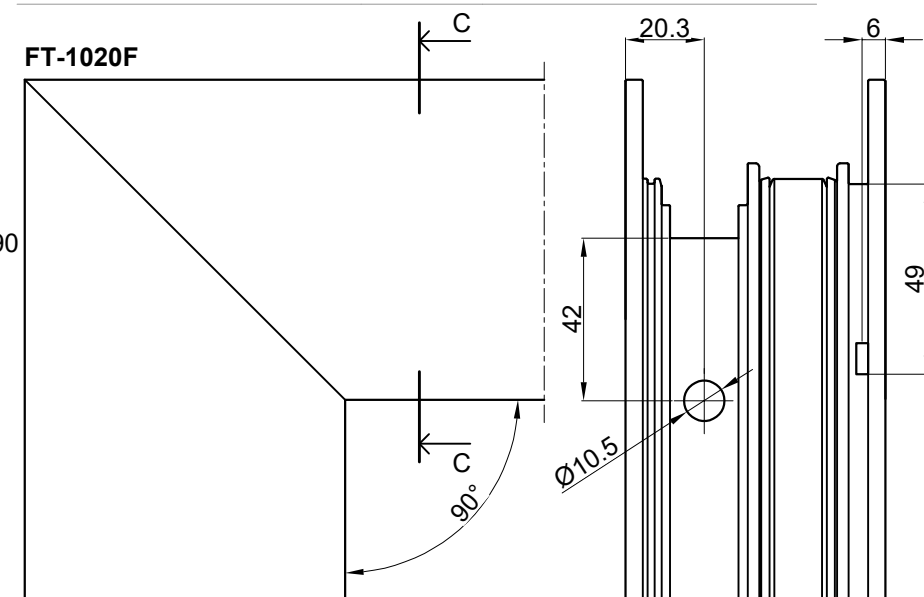

- Spajanje kutnikom **710.188** uprešavanjem stijenke profila u kutnik
- Uprešavanje izvesti kliještima art.240.001 ili strojno
- Corner bracket connection **710.188** aluminium profile corner crimping
- Corner crimping perform with pliers art.240.001 or with machine

- Spajanje kutnikom **710.490** vijcima M8x13 -tip Feal (431.266)
- Obrada rupe na glodalici (bušilici) vretenastim glodalom (svrdlom) Ø10.5
- Corner bracket connection **710.490** with screws M8x13 - tip Feal (431.266)
- Hole processing with Ø10.5 end mill

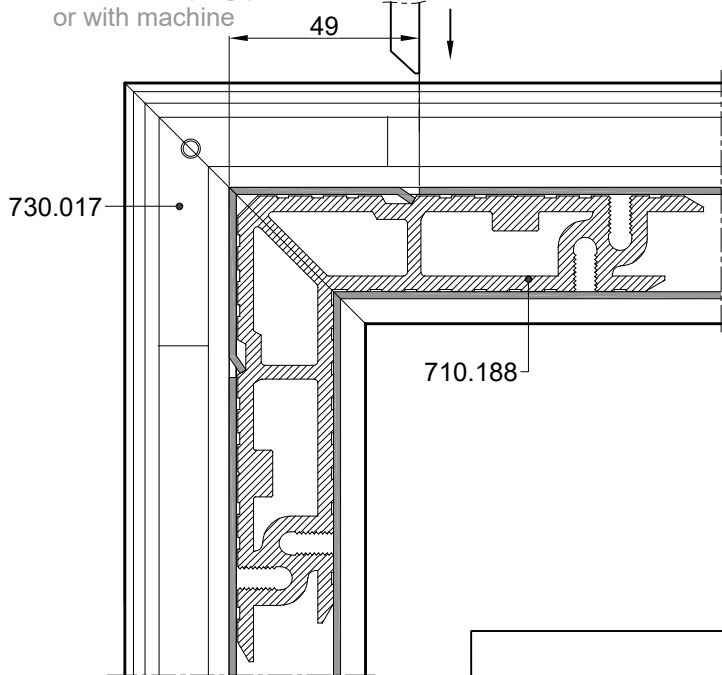

PRESJEK A-A  
CROSS SECTION A-A

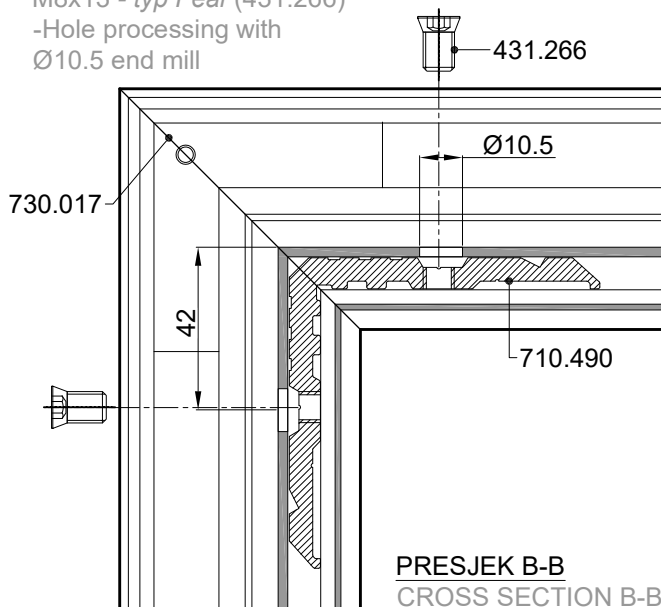

PRESJEK B-B  
CROSS SECTION B-B

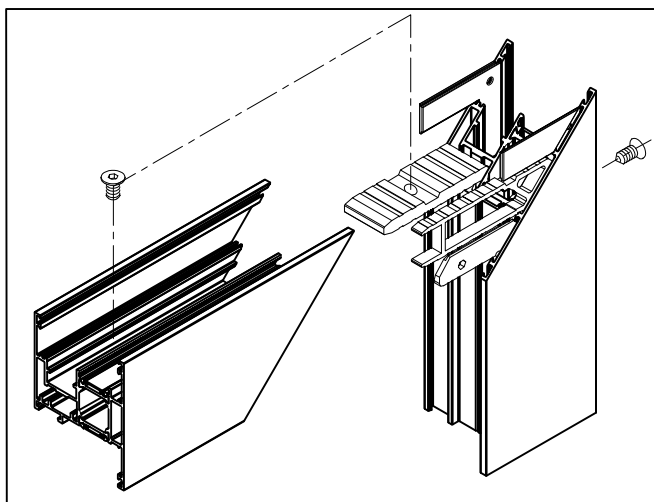

### PRESJEK C-C CROSS SECTION C-C

### SPAJANJE PROFILA FT-1022F KUTNICIMA CONNECTION OF PROFILE FT-1022F WITH CORNER BRACKETS

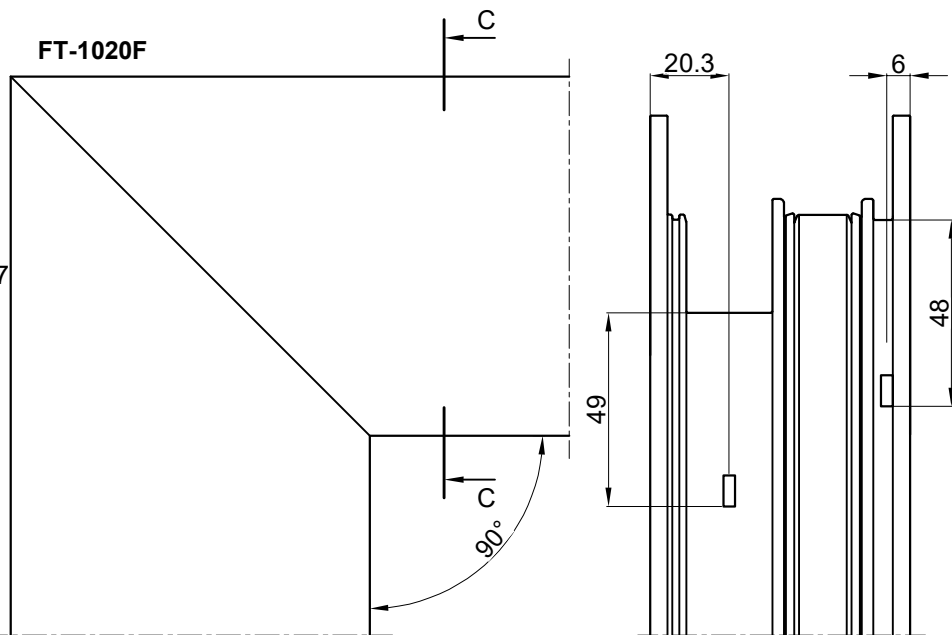
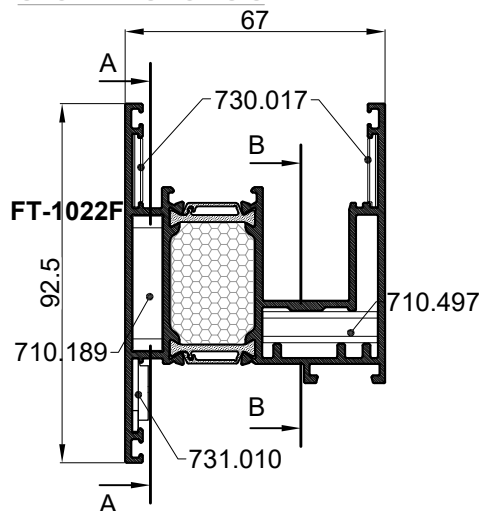

- Spajanje kutnikom **710.189** uprešavanjem stijenke profila u kutnik
- Uprešavanje izvesti kliještima art.240.001 ili strojno
- Corner bracket connection **710.189** aluminium profile corner crimping
- Corner crimping perform with pliers art.240.001 or with machine

- Spajanje kutnikom **710.497** uprešavanjem stijenke profila u kutnik
- Uprešavanje izvesti kliještima art.240.001 ili strojno
- Corner bracket connection **710.497** aluminium profile corner crimping
- Corner crimping perform with pliers art.240.001 or with machine

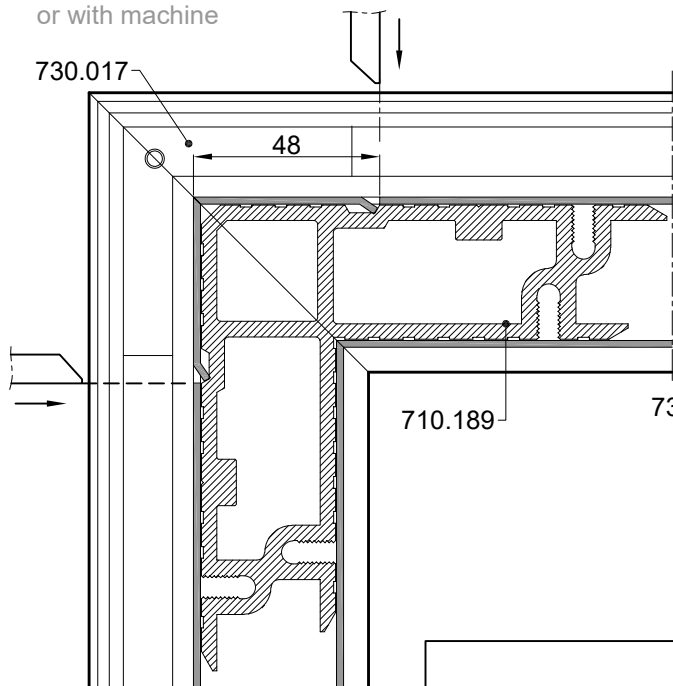

**PRESJEK A-A**  
CROSS SECTION A-A

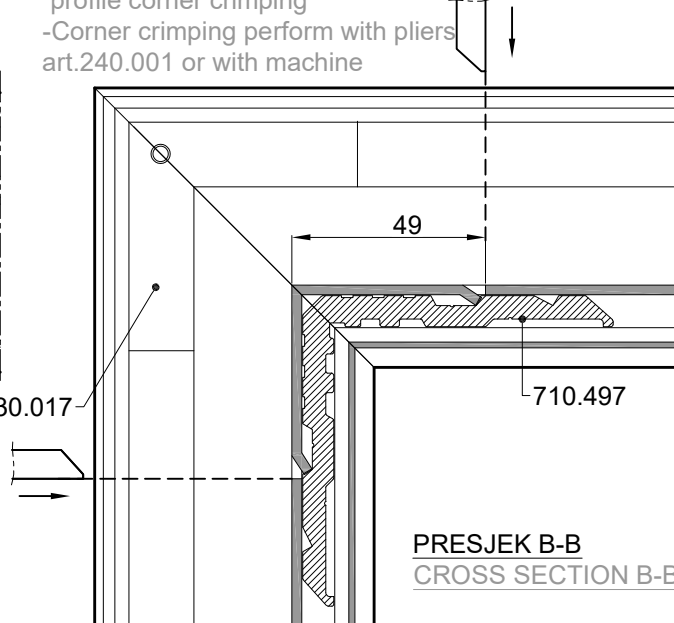

**PRESJEK B-B**  
CROSS SECTION B-B

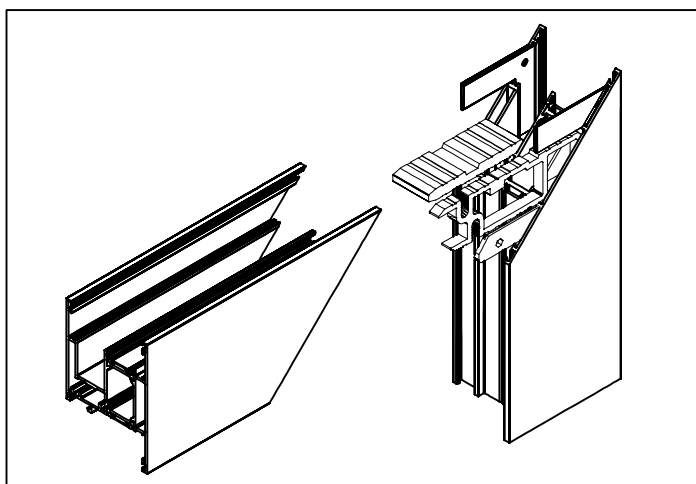

### PRESJEK C-C CROSS SECTION C-C

### SPAJANJE PROFILA FT-1022F KUTNICIMA CONNECTION OF PROFILE FT-1022F WITH CORNER BRACKETS

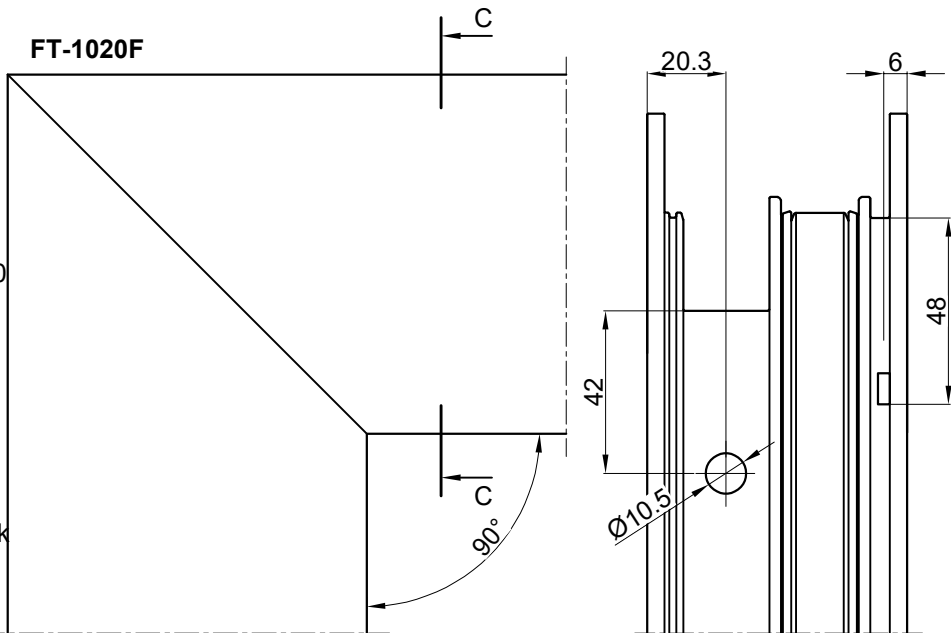
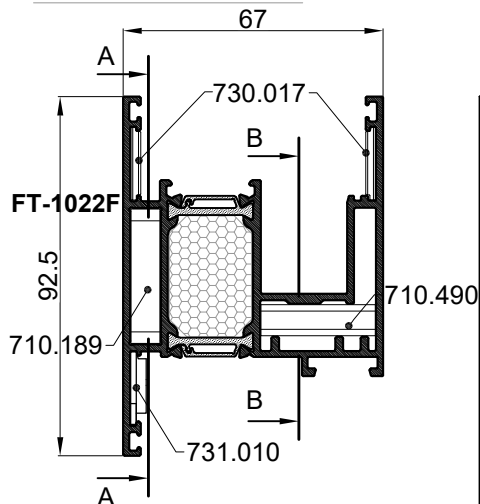

- Spajanje kutnikom **710.189** uprešavanjem stijenke profila u kutnik
- Uprešavanje izvesti kliještima art.240.001 ili strojno
- Corner bracket connection **710.189** aluminium profile corner crimping
- Corner crimping perform with pliers art.240.001 or with machine

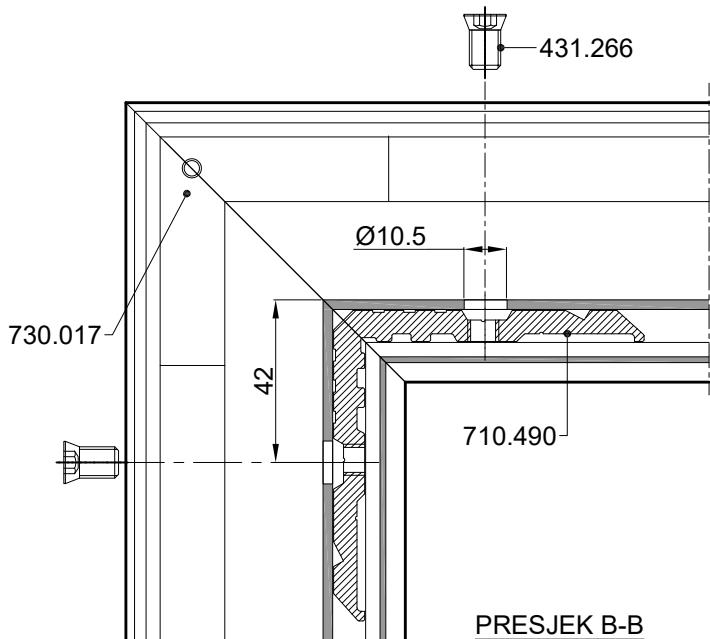
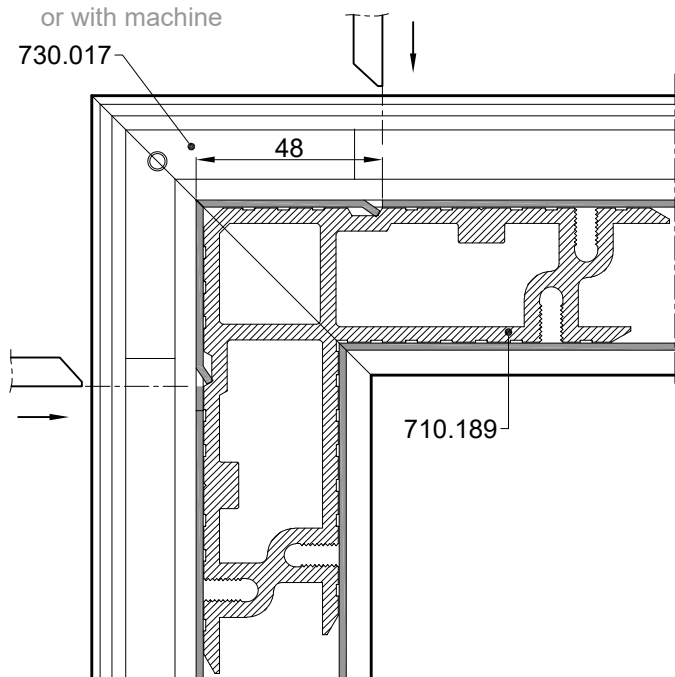

PRESJEK A-A  
CROSS SECTION A-A

PRESJEK B-B  
CROSS SECTION B-B

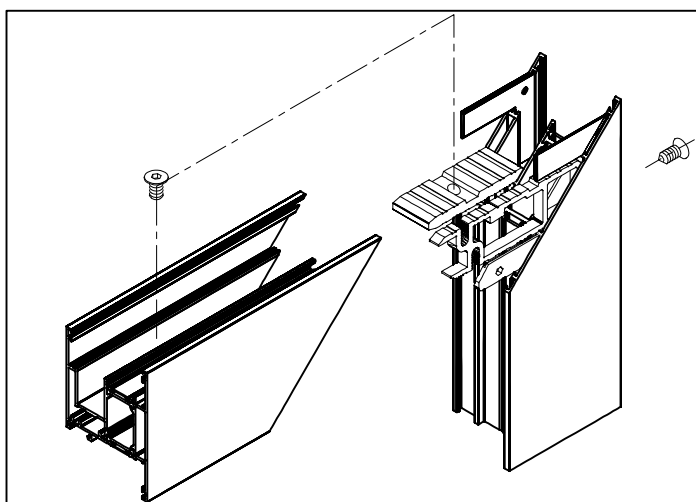

SPAJANJE PROFILA KUTNICIMA POD KUTEM OD 90°  
CONNECTION OF PROFILES WITH CORNER BRACKETS UNDER 90°

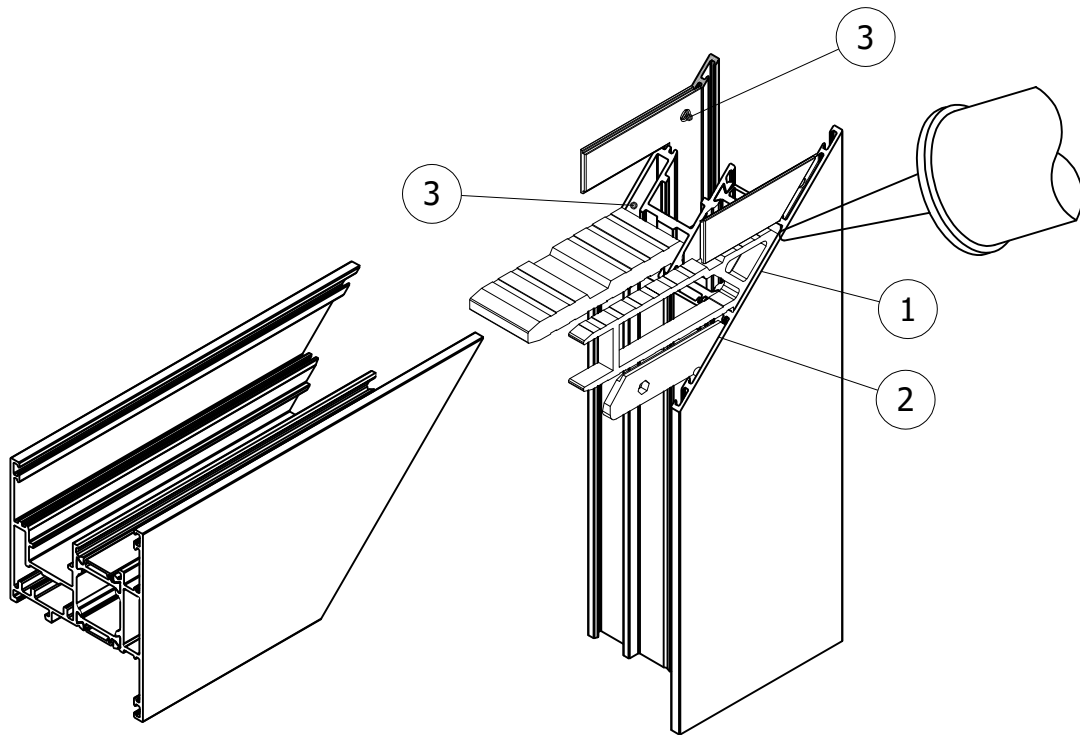

POSTUPAK SPAJANJA PROFILA:

1. Površine koje se spajaju-rezove očistiti i odmastiti prikladnim sredstvom /npr. Sika Remover 208; Wurth-kat.br.:892 130 30/.
2. Premazati površine koje se spajaju ljepilom za metal /npr. Sika Force 7851; Wurth-kat.br.:892 130 010/.
3. Ljepilo za metal ušpricati u komore za kutnik (po opsegu komore)
4. Profile s kutnicima izravnati i spojiti
5. Dio ljepila koji iscure između rezova očistiti sredstvom za čišćenje i odmašćivanje /npr. Sika Remover 208; Wurth-kat.br.:892 130 30/.

NAPOMENA:

Ovaj postupak spajanja profila primjenjiv je za sve Feal-ove kutnike i njima odgovarajuće komore. Lijepljenjem rezova i kutnika ljepilima za metal osigurava se potrebna zrako- i vodonepropusnosti spoja kao i dodatna mehanička čvrstoća spoja.

PROFILE CONNECTION PROCEDURE:

1. Surfaces that are connecting - clean and degreased the cut with suitable products /e.g. Sika Remover 208; Wurth-kat. no.:892 130 30/.
2. Smear surfaces that are connecting with metal glue /e.g. Sika Force 7851; Wurth-kat.no.:892 130 010/.
3. Spurt metal glue into chambers for the corner bracket (on chamber circumference)
4. Level profiles with corner brackets and connect
5. Leaking glue that comes from the joints remove with cleaning and degrease product /e.g. Sika Remover 208; Wurth-kat.no.:892 130 30/.

REMARK:

This profile connection procedure is applicable for all Feal corner brackets and their appropriate chambers. Gluing cuts and corners with metal glues provides necessary air and water tightness of the joint and additional mechanical properties.

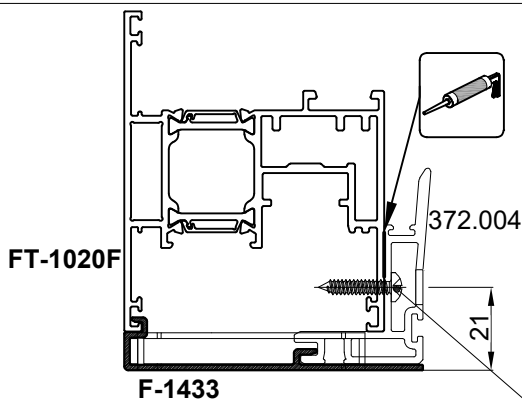

Obrada al. profila **F-1433** i pvc profila **372.004**  
(za profil krila FT-1020F) - OTVARAJUĆE KRILLO

- mjera pilanja  $H(F-1433)=H_{krila}$
- obradu profila F-1433 i 372.004 raditi na glodalici vretenastim glodalom umetci (od gume) na krajevima profila

Processing al. profile **F-1433** and pvc profile **372.004**  
(for sash profile FT-1020F) - OPENING SASH

- cut lenght  $H(F-1433)=H_{sash}$
- proces profile F-1433 i 372.004 on milling machine with end mill inserts (of rubber) on the profile end

spajanje vijkom 3.9x19 (DIN 7981)

-svakih max.400 mm

screw connection 3.9x19 (DIN 7981)

-every max.400 mm

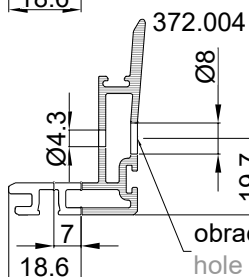
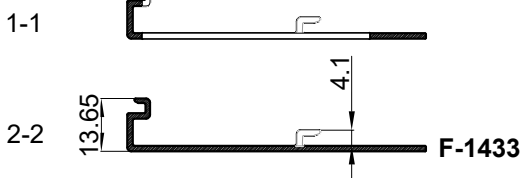
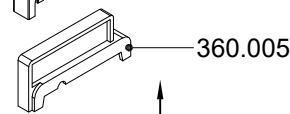
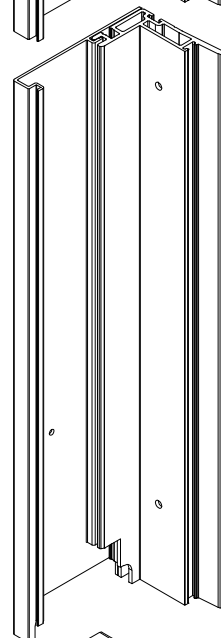
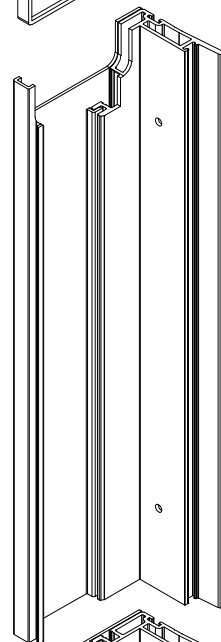
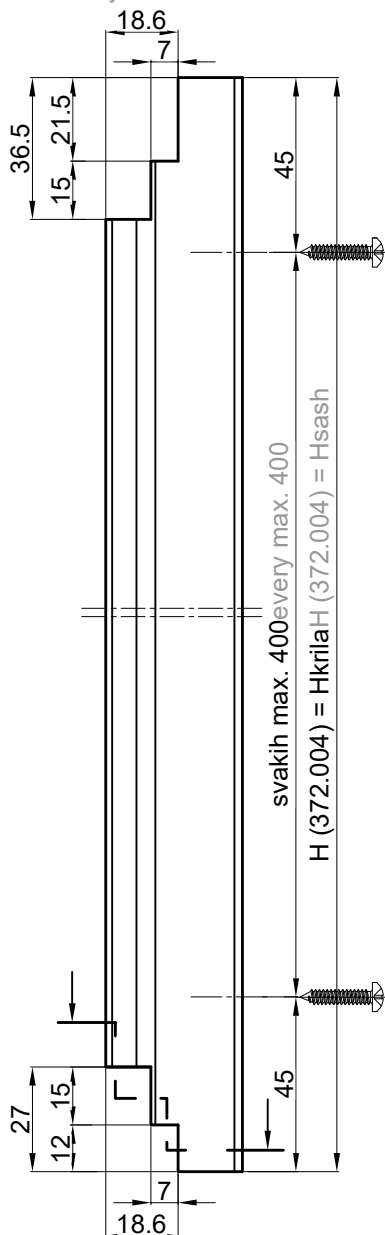
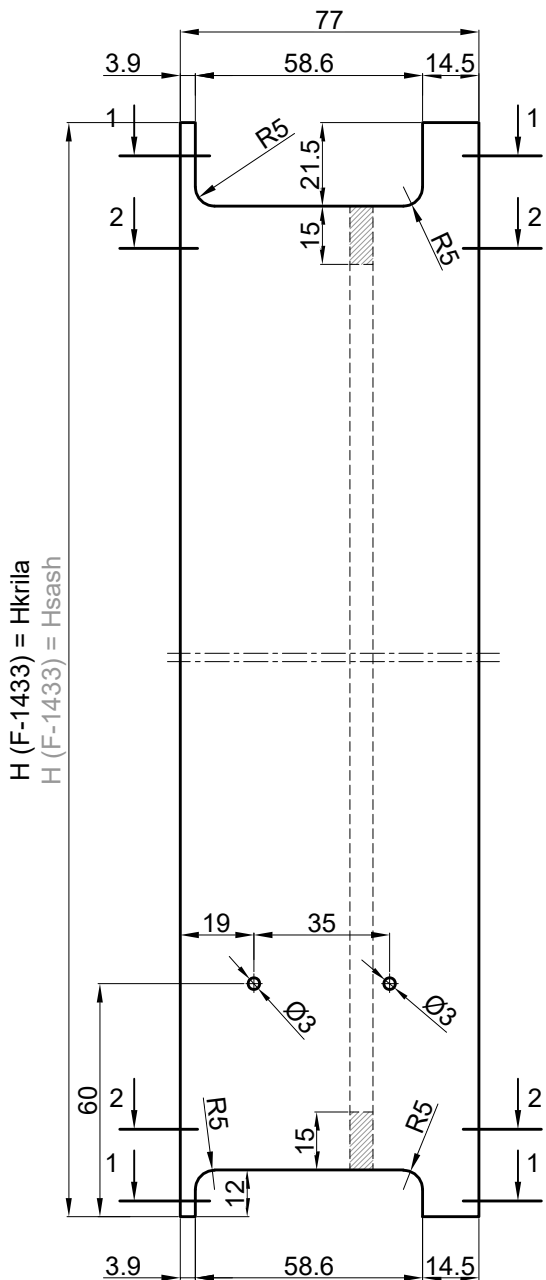
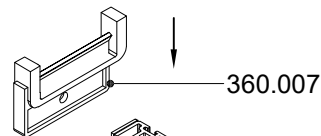
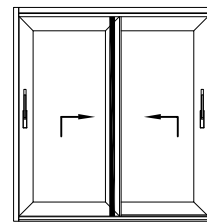

vijak 3.9x19 (DIN 7981)  
srew 3.9x19 (DIN 7981)

obrada rupa - stupnjevanim glodalom (DIN8374)  
hole processing - sublant (DIN8374)

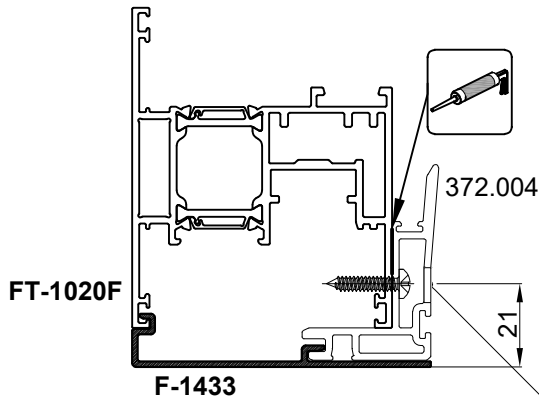

Obrada al. profila **F-1433** i pvc profila **372.004**  
(za profil krila FT-1020F) - OTVARAJUĆE KRILO

- mjera pilanja  $H(F-1433)=H_{krila}$
- obradu profila F-1433 i 372.004 raditi na glodalici vretenastim glodalom

Processing al. profile **F-1433** and pvc profile **372.004**

(for sash profile FT-1020F) - OPENING SASH

- cut lenght  $H(F-1433)=H_{sash}$
- proces profile F-1433 i 372.004 on milling machine with end mill

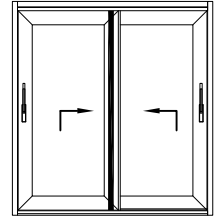

spajanje vijkom 3.9x19 (DIN7981)

-svakih max.400 mm

screw connection 3.9x19 (DIN7981)

-every max.400 mm

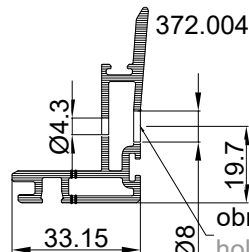
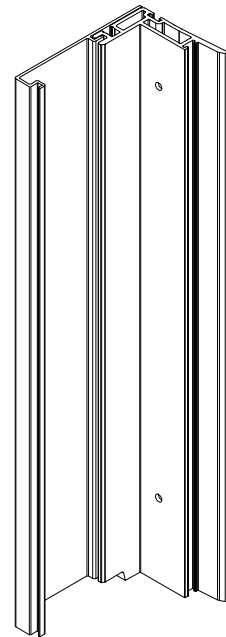
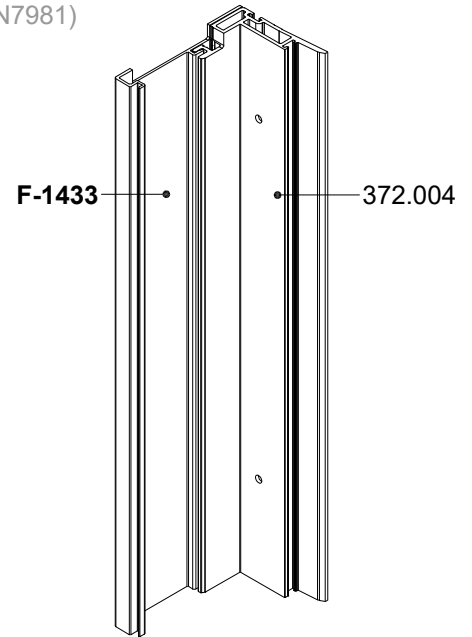
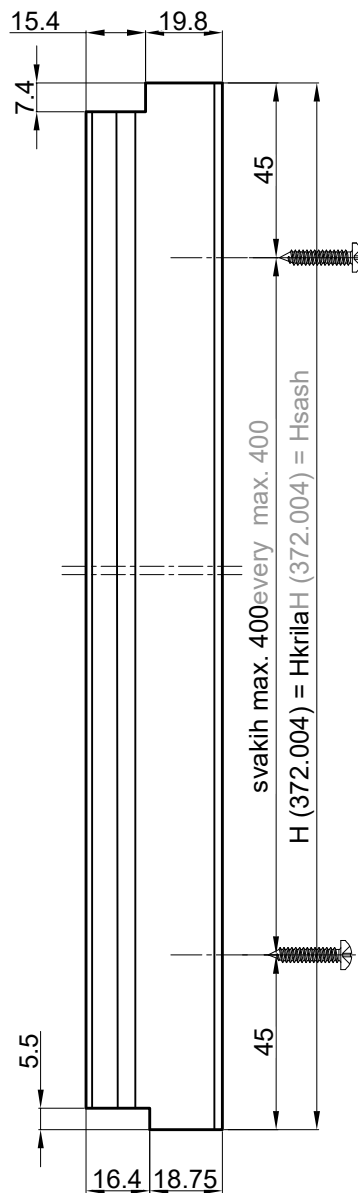
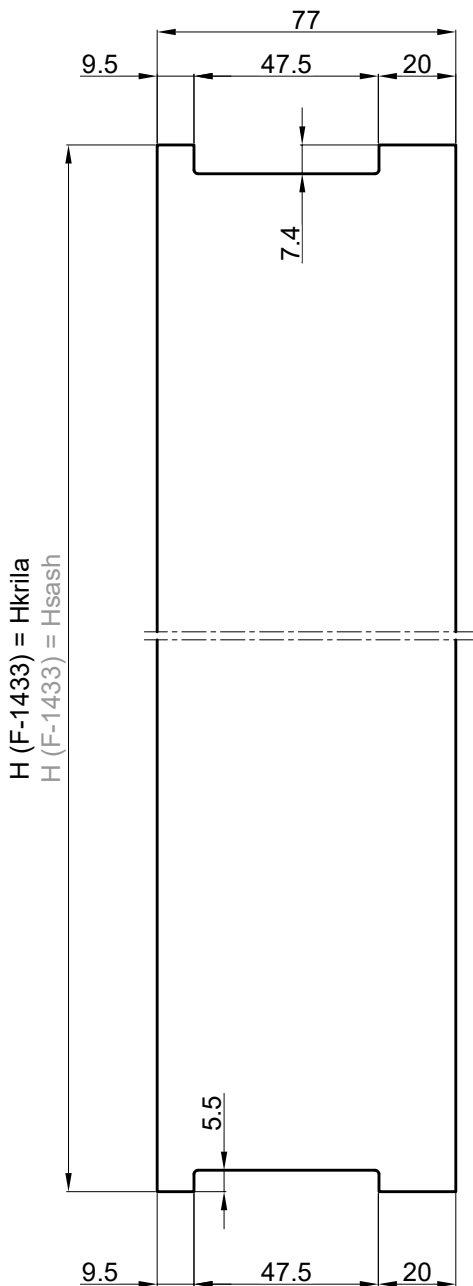

vijak 3.9x19 (DIN 7981)  
srew 3.9x19 (DIN 7981)

obrada rupa - stupnjevanim glodalom (DIN8374)  
hole processing - sublant drill (DIN8374)

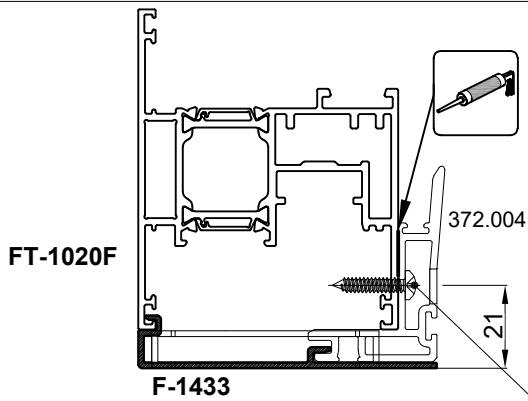

Obrada al. profila **F-1433** i pvc profila **372.004**

(za profil krila FT-1020F) - **FIKSNO KRILLO**

- mjera pilanja  $H(F-1433)=H_{krila}$
- obradu profila F-1433
- raditi na glodalici vretenastim glodalom
- umetci (od gume) na krajevima profila

Processing al. profile **F-1433** and pvc profile **372.004**

(for sash profile FT-1020F) - **FIXED SASH**

- cut lenght  $H(F-1433)=H_{sash}$
- proces profile F-1433 i 372.004 on milling machine with end mill
- inserts (of rubber) on the profile end

spajanje vijkom 3.9x19 (DIN7981)

-svakih max.400 mm

screw connection 3.9x19 (DIN7981)

-every max.400 mm

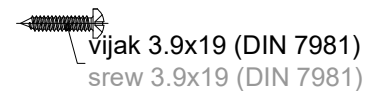
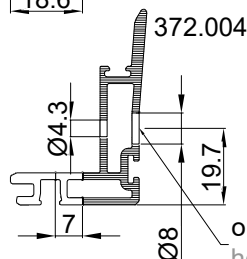
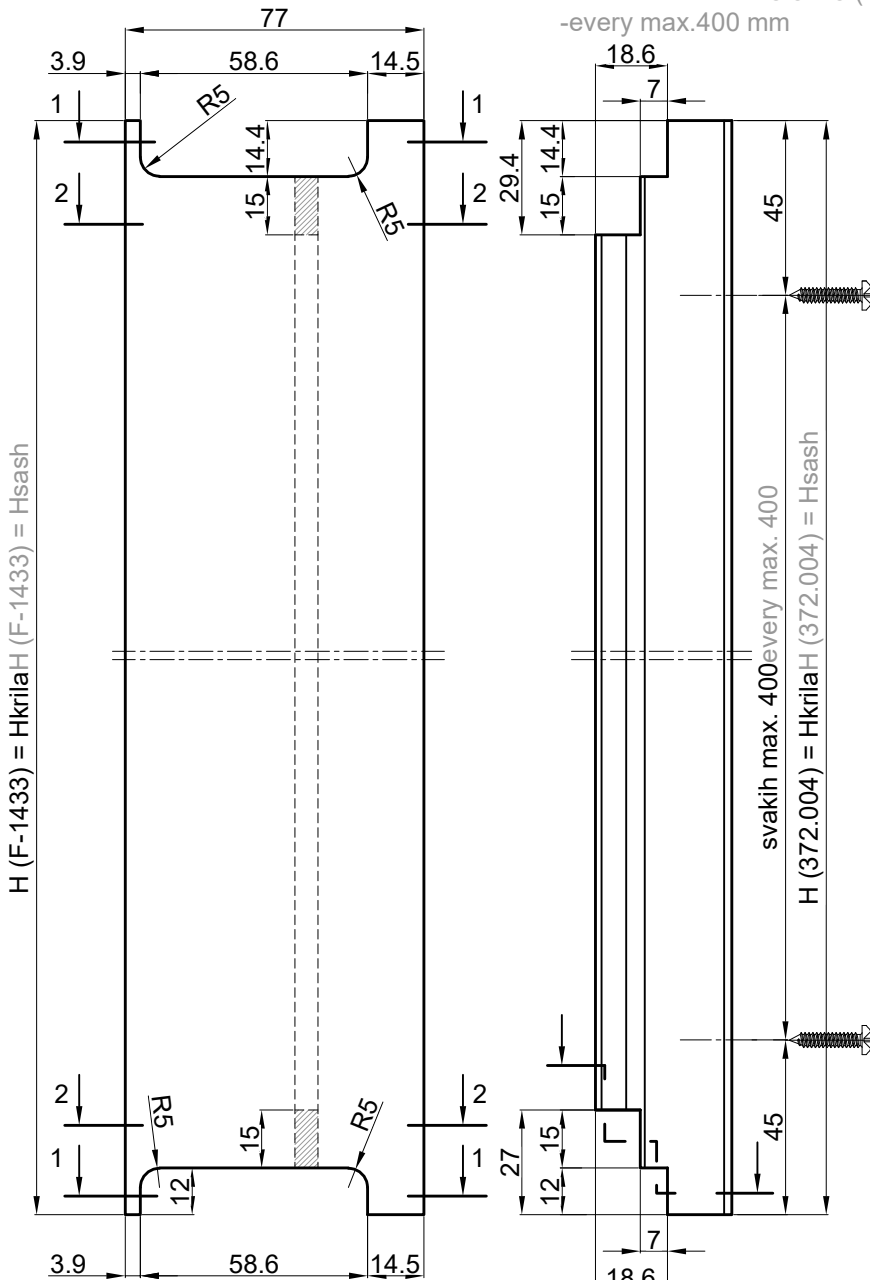
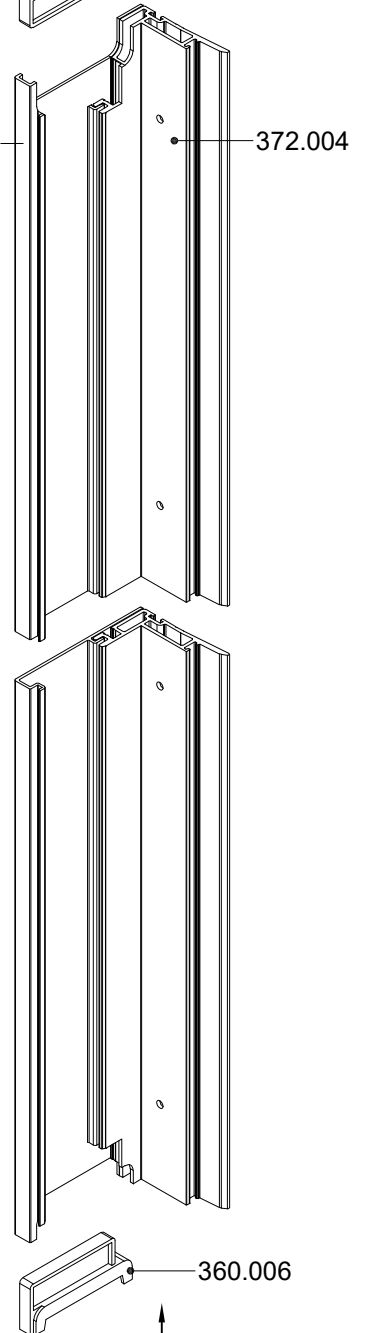
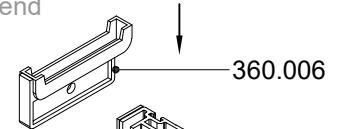
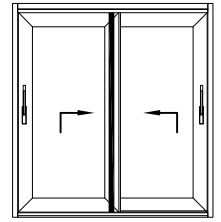

obrada rupa - stupnjevanim glodalom (DIN8374)  
hole processing - sublant drill (DIN8374)

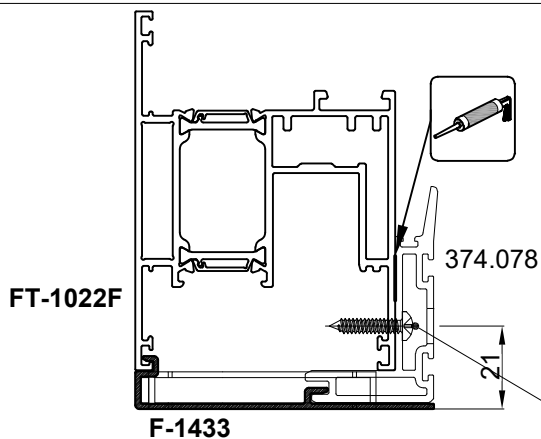

Obrada al. profila **F-1433** i pvc profila **374.078**  
(za profil krila FT-1022F) - OTVARAJUĆE KRILO

- mjera pilanja  $H(F-1433)=H_{krila}$
- obradu profila F-1433 i 374.078 raditi na glodalici vretenastim glodalom
- umetci (od gume) na krajevima profila

Processing al. profile **F-1433** and pvc profile **374.078**  
(for sash profile FT-1020F) - OPENING SASH

- cut lenght  $H(F-1433)=H_{sash}$
  - proces profile F-1433 i 372.004 on milling machine with end mill
  - inserts (of rubber) on the profile end
- spajanje vijkom 3.9x19 (DIN7981)  
-svakih max.400 mm  
screw connection 3.9x19 (DIN7981)  
-every max.400 mm

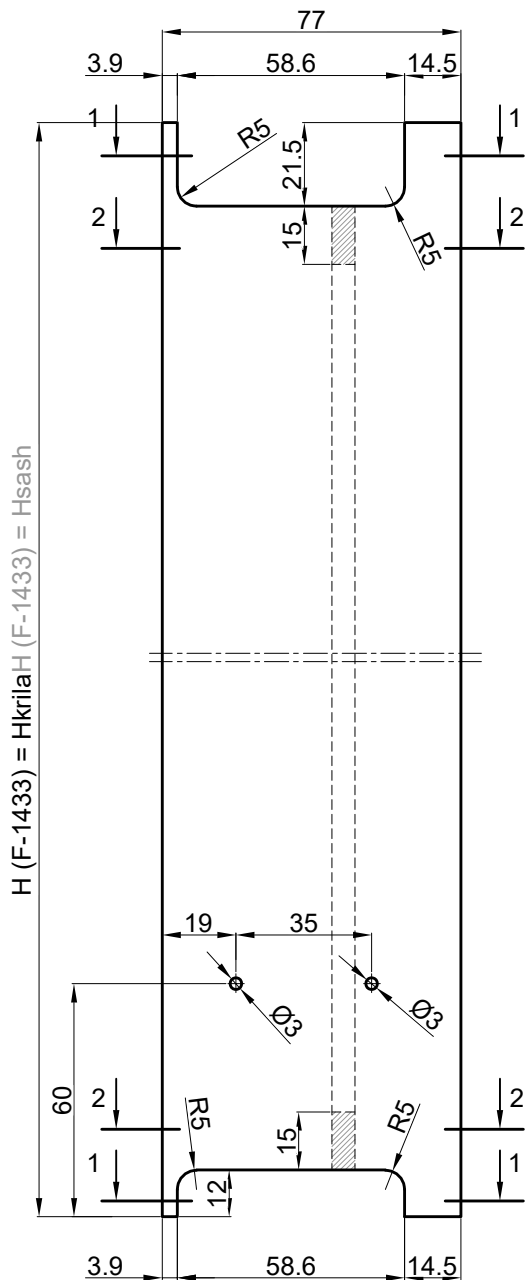
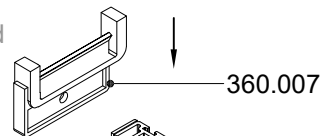
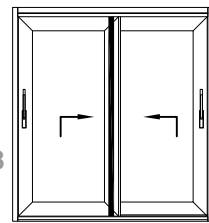

$H(F-1433) = H_{krila}H(F-1433) = H_{sash}$

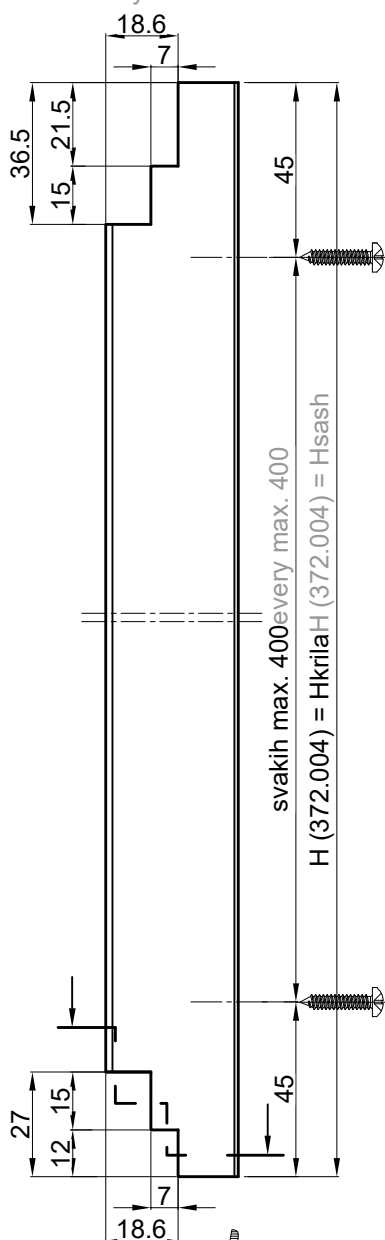

svakih max. 400 every max. 400

$H(372.004) = H_{krila}H(372.004) = H_{sash}$

F-1433

374.078

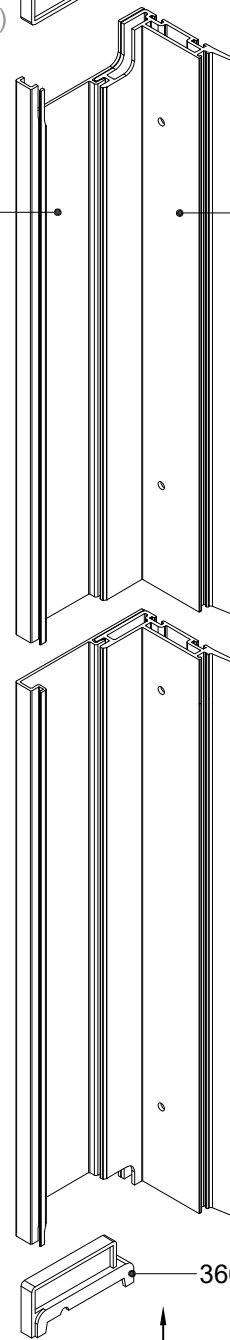

1-1

2-2



F-1433

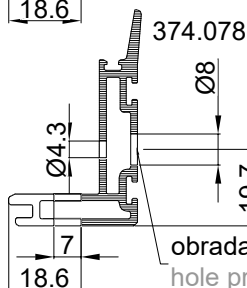

374.078

Ø4.3

Ø8

19.7

7

18.6

obrada rupa - stupnjevanim glodalom (DIN8374)  
hole processing - sublant drill (DIN8374)

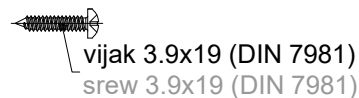

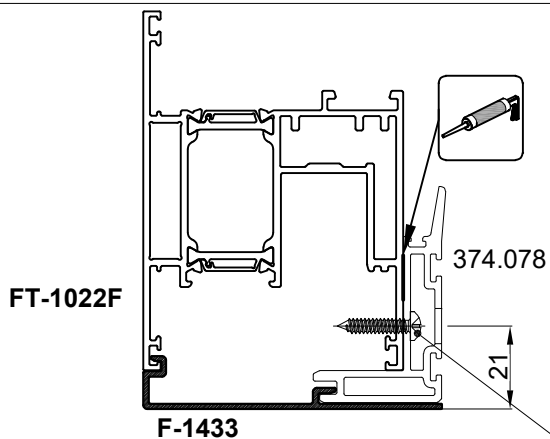

Obrada al. profila **F-1433** i pvc profila **374.078**  
(za profil krila FT-1022F) - FIKSNO KRILO

- mjera pilanja  $H(F-1433)=H_{krila}$
- obradu profila F-1433 i 374.078 raditi na glodalici vretenastim glodalom

Processing al. profile **F-1433** and pvc profile **374.078**  
(for profile FT-1022F) - FIXED SASH

- cutting lenght  $H(F-1433)=H_{sash}$
- proces profile F-1433 i 372.004 on milling machine with end mill

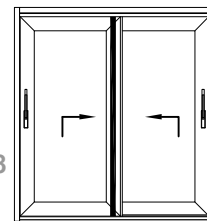

spajanje vijkom 3.9x19 (DIN7981)  
-svakih max.400 mm  
screw connection 3.9x19 (DIN7981)  
-every max.400 mm

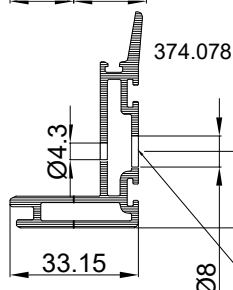
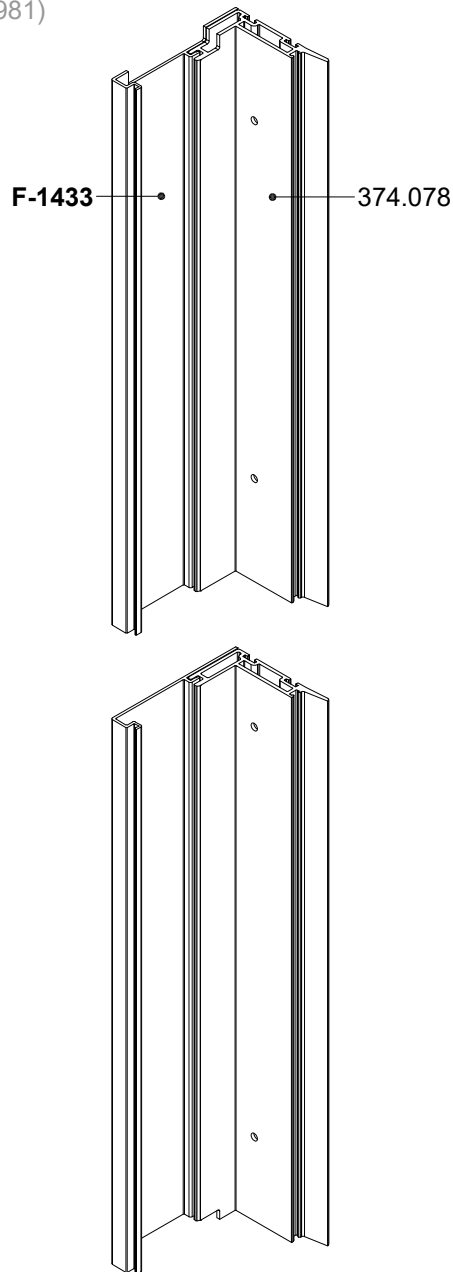
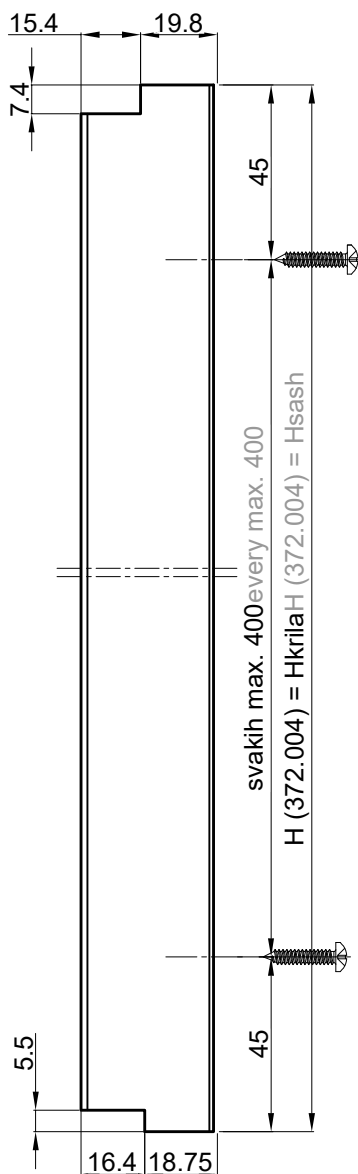
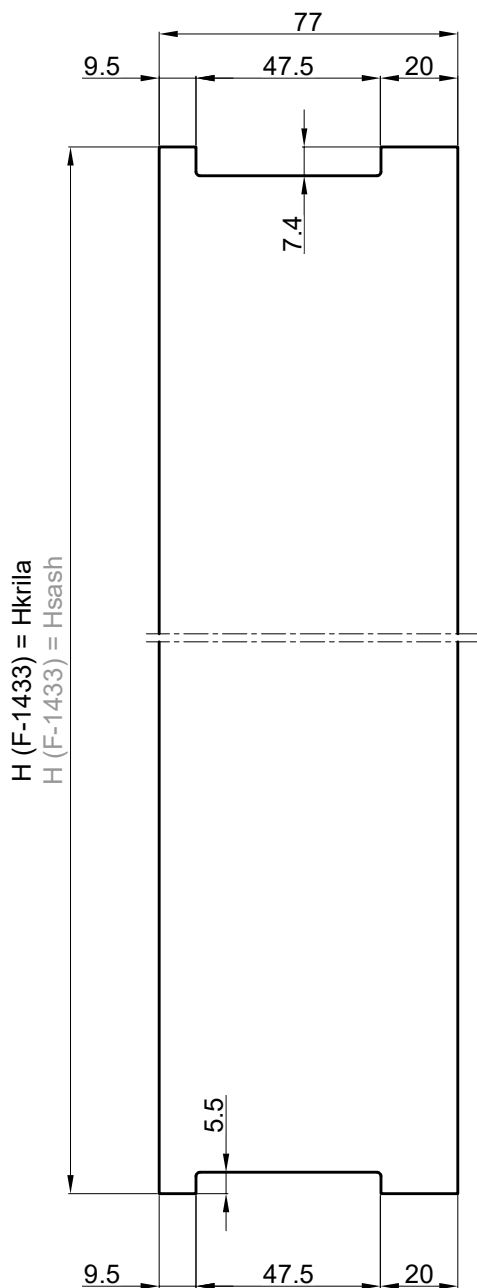

vijak 3.9x19 (DIN 7981)  
srew 3.9x19 (DIN 7981)

obrada rupa - stupnjevanim glodalom (DIN8374)  
hole processing - sublant drill (DIN8374)

**UMETCI NA SPOJEVIMA KRILA**  
**INSERTS ON SASH JOINTS**

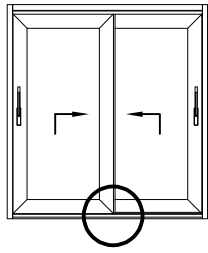

FT-1020F

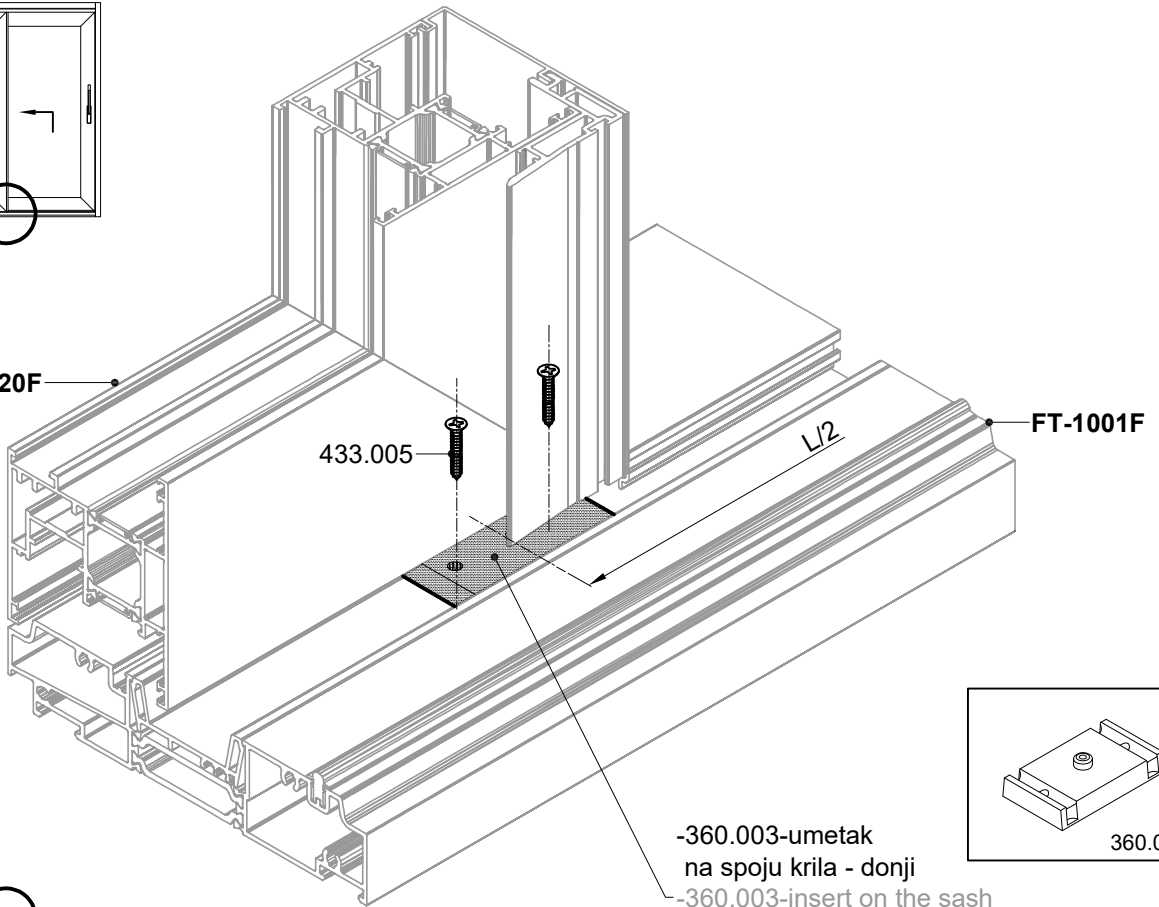

433.005

L/2

FT-1001F

-360.003-umetak  
na spoju krila - donji  
-360.003-insert on the sash  
joint - lower

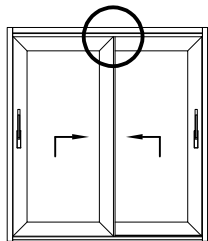
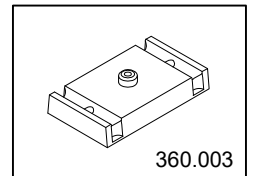

FT-1020F

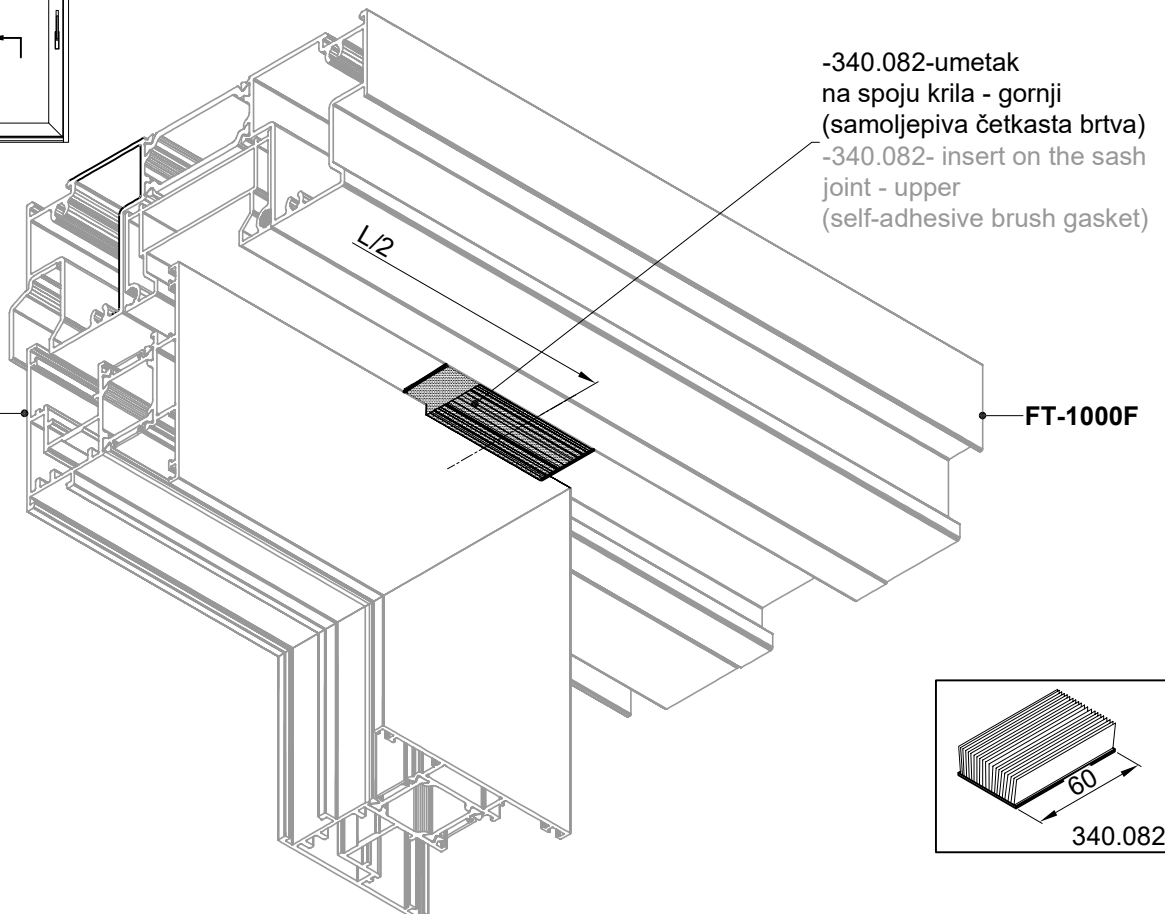

L/2

FT-1000F

-340.082-umetak  
na spoju krila - gornji  
(samoljepiva četkasta brtva)  
-340.082- insert on the sash  
joint - upper  
(self-adhesive brush gasket)

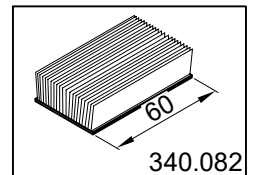

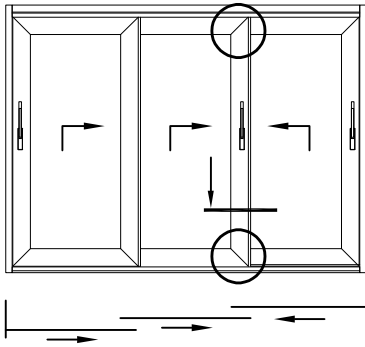

Obrada na profilu krila  
Obrada na profilu krila

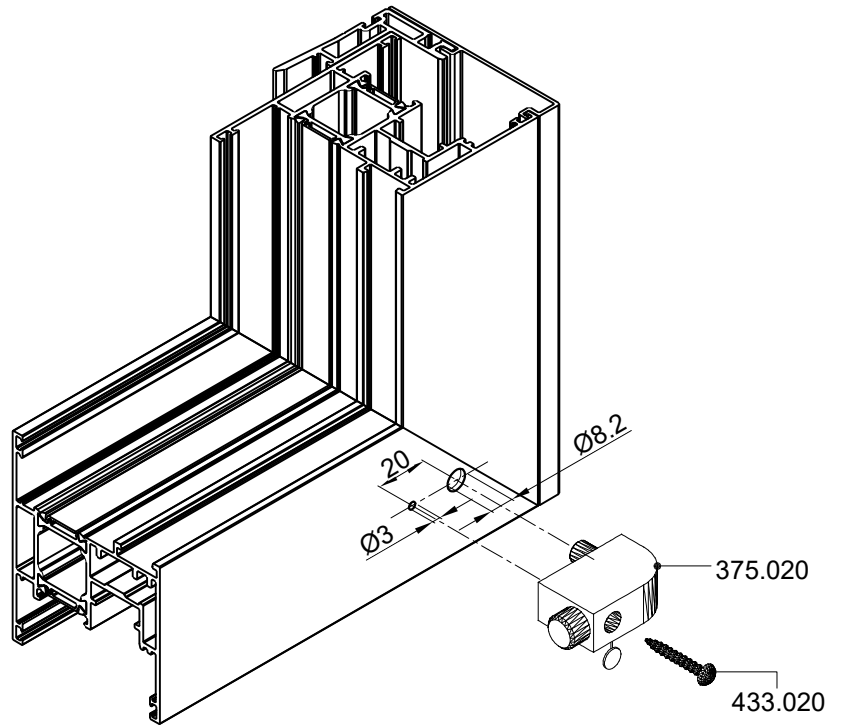

**UGRADNJA UBLAŽIVAČA UDARA KRILA - 375.020**

-koristi se kod dvokrilnog, trokrilnog i četverokrilnog podizno-kliznog, te trokrilnog podizno-kliznog s fiksnim dijelom (za srednje krilo kao zaštita od udara krila u ručku)

-ugrađuje se simetrično na krilo, gore i dolje  
**SASH BUMPER MONTAGE - 375.020**

-is used at double sash, triple sash on four-sash lift and slide system, as well as at triple lift and slide sash with fixed part (in the middle sash for protection from sash hitting the handle)

-it is mounted symmetrical to the sash, up and down

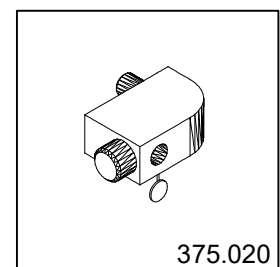
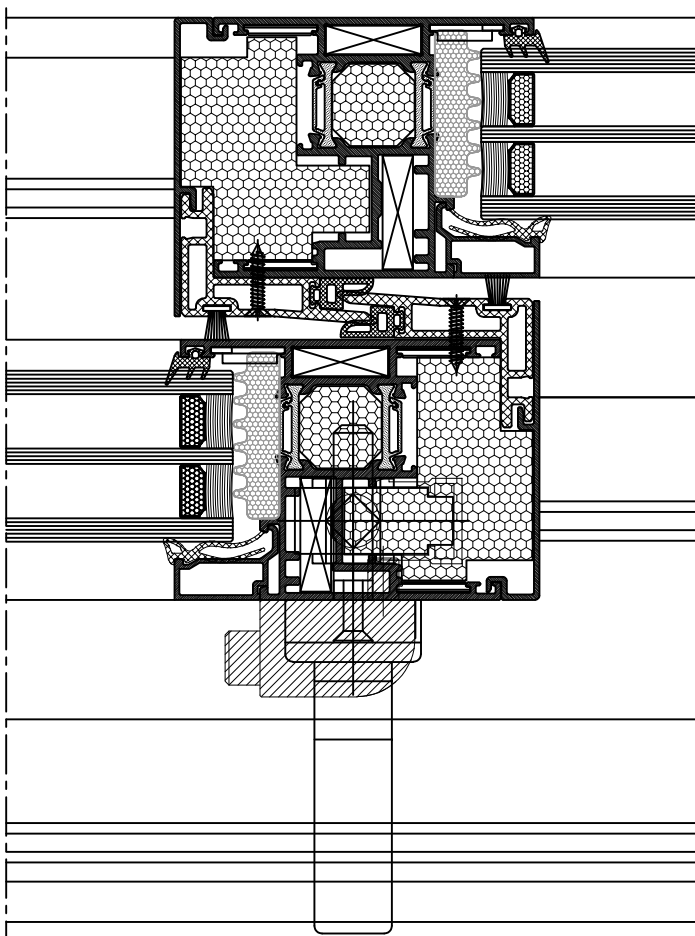

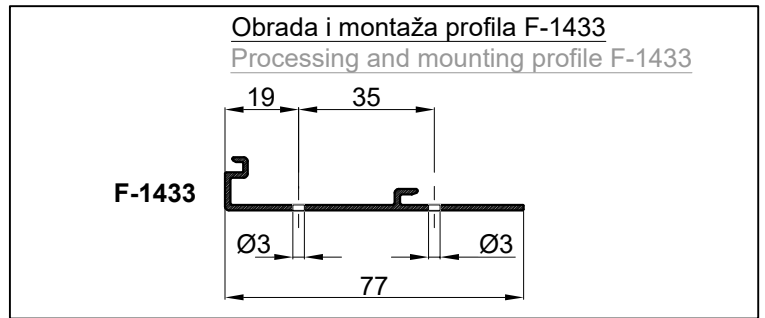
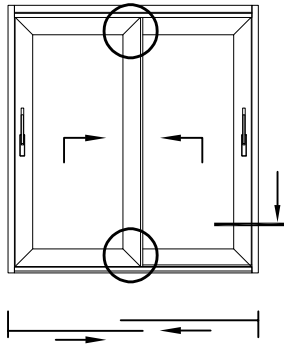

### UGRADNJA UBLAŽIVAČA UDARA KRILA 345.010

- koristi se kod dvokrilnog i četverokrilnog podizno-kliznog s fiksnim dijelom
  - ugrađuje se na krilo, simetrično gore i dolje
- SASH BUMPER MONTAGE 345.010
- is used at double and four lift and slide sash with fixed part
  - it is mounted on the sash, symmetrical up and down

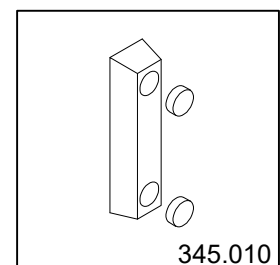
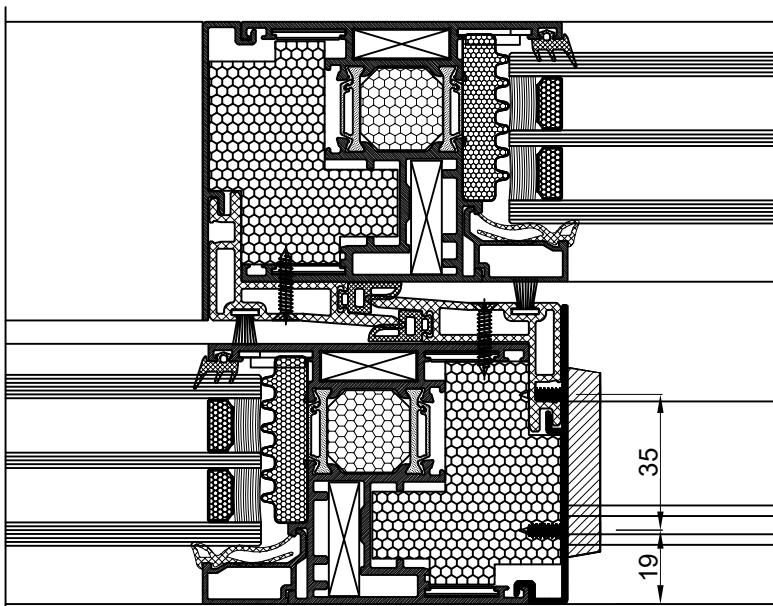
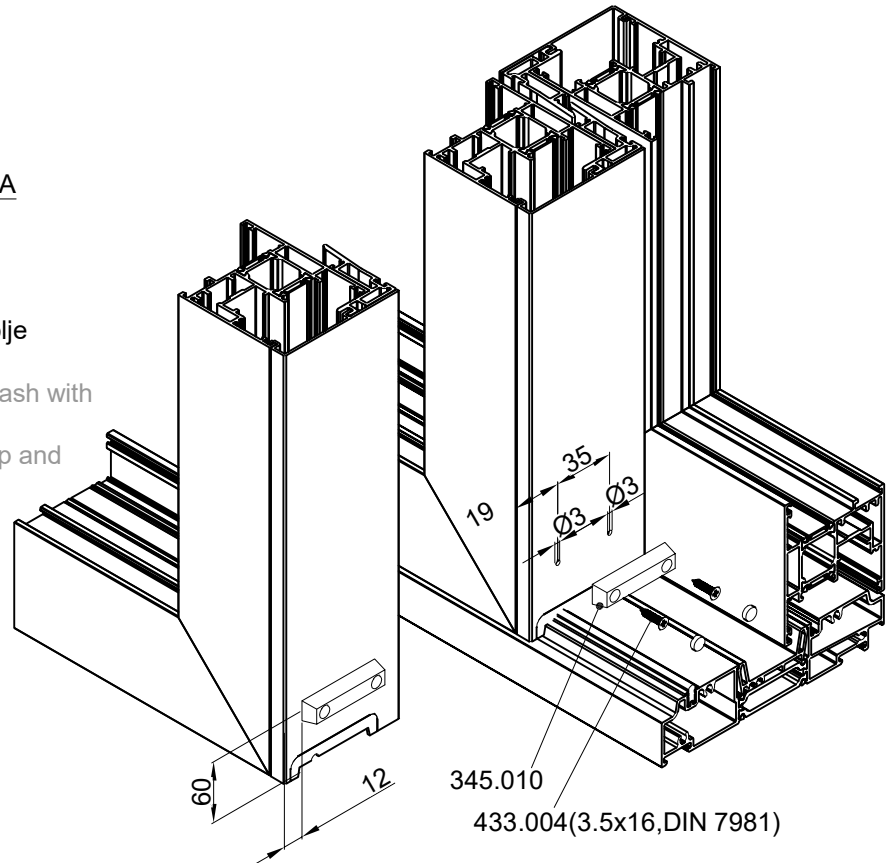

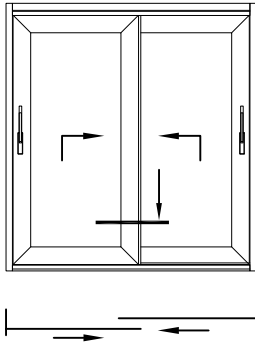

**UGRADNJA KOPČE 375.048 ZA PROFIL F-1298**

-koristi se kod podizno-kliznog s fiksnim dijelom,  
za fiksiranje profila F-1298 za profil rama  
FT-1001F u  
donjem pojasu na vanjskoj stazi  
-ugrađuje se svakih max.350 mm  
**CLAMP MOUNTING 375.048 FOR PROFILE  
F-1298**

-is used by lift and slide sash with fixed part,  
for fixing profile F-1298 on the frame profile  
FT-1001F in lower zone on the exterior side  
-it is mounted every max.350 mm

POGLED S VANA  
OUTSIDE VIEW

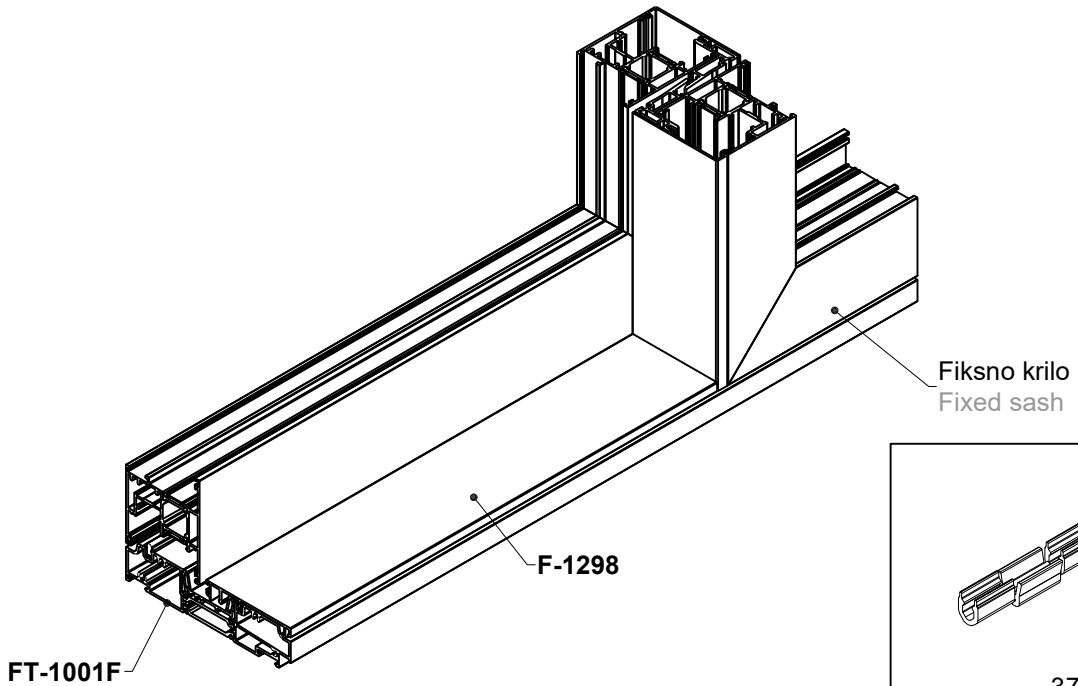
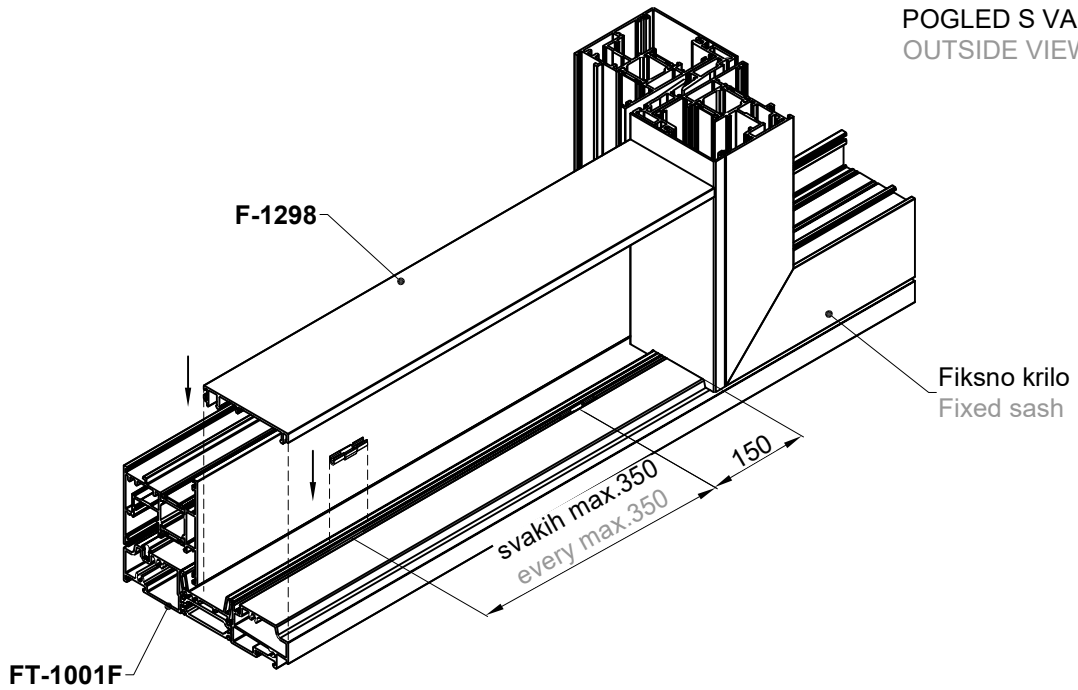

Rezanje pvc profila donje vodoravnice okvira rama  
Cutting of lower profile pvc frame transom  
L (378.002) = L-86 kom.1

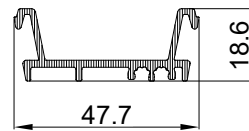
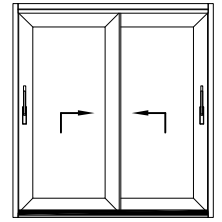
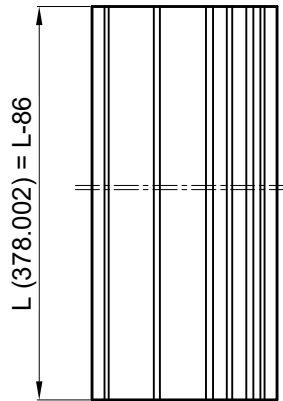
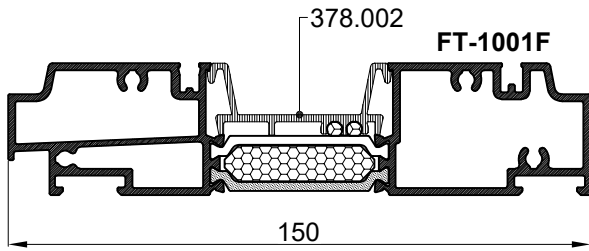

Rezanje pvc profila gornje vodoravnice okvira rama  
Cutting of upper profile pvc frame transom  
L (378.003) = L-86 kom.1

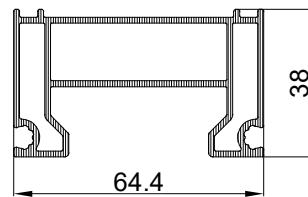
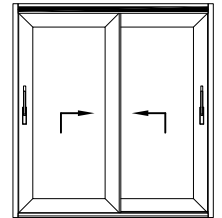
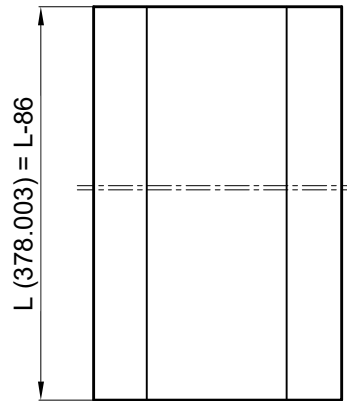
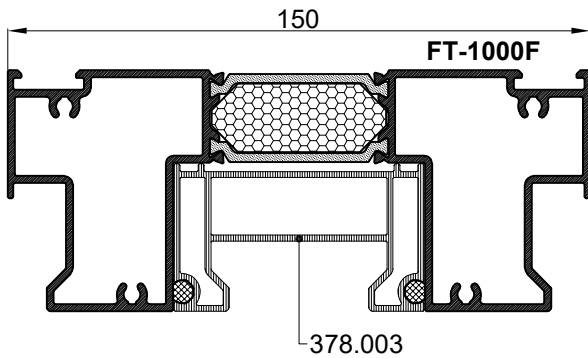

Rezanje pvc profila okomice okvira rama  
Cutting of profile pvc on vertical frame profile  
H (378.004) = H kom.1

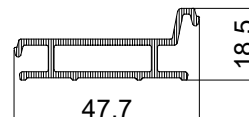
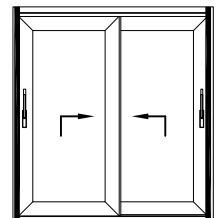
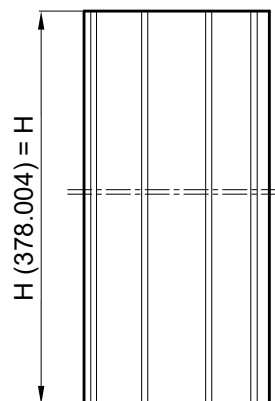
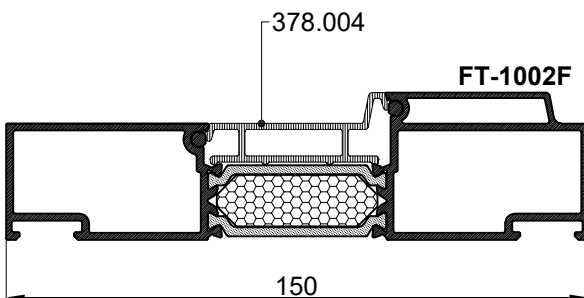

Rezanje pvc profila donje vodoravnice okvira rama kod trostranog profila

L (378.002) = L-86 (prema pvc umetku) kom.1

L (378.002) = L-60 (prema al profilu) kom.1

Cutting of lower profile pvc frame transom by tri-way profile

L (378.002) = L-86 (towards pvc insert) no.1

L (372.002) = L-60 (towards al profile) no.1

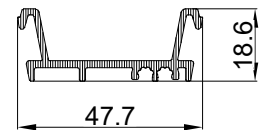
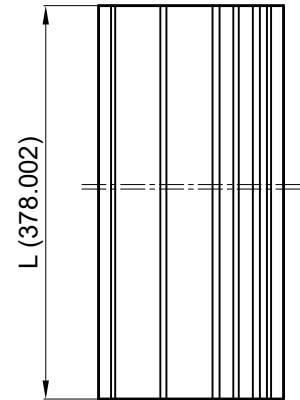
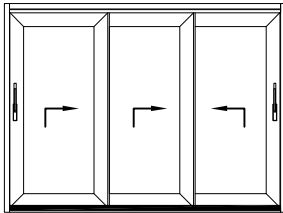
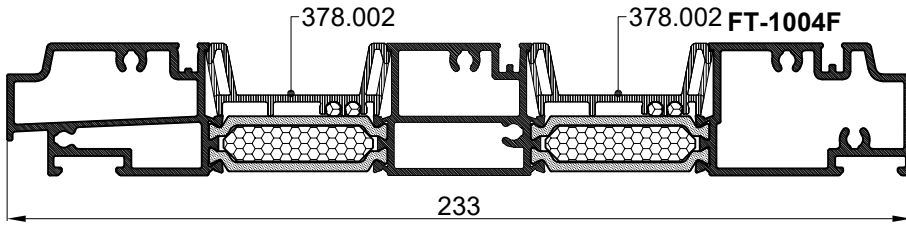

Rezanje pvc profila gornje vodoravnice okvira rama kod trostranog profila

L (378.003) = L-86 (prema pvc umetku) kom.1

L (378.003) = L-60 (prema al profilu) kom.1

Cutting of upper profile pvc frame transom by tri-way profile

L (378.003) = L-86 (towards pvc insert) no.1

L (378.003) = L-60 (towards al profile) no.1

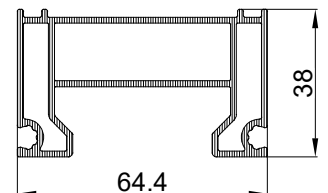
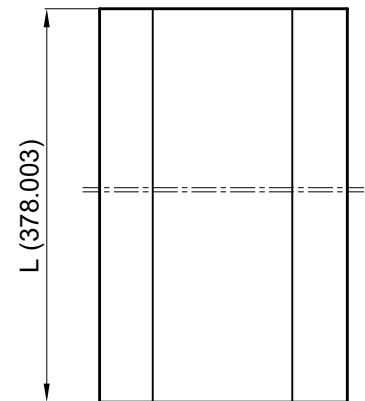
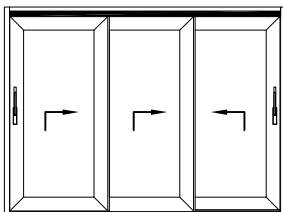
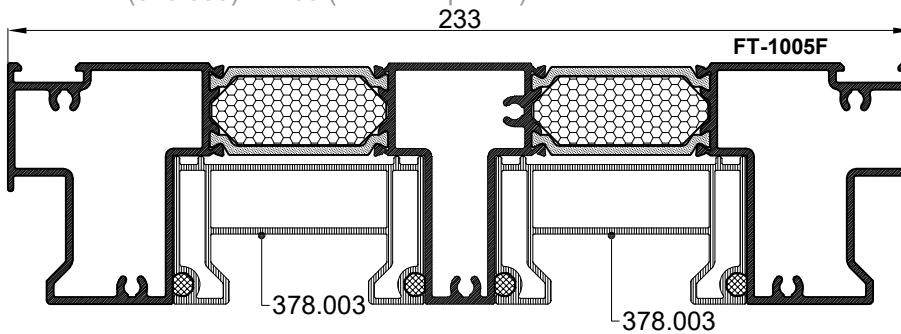

Rezanje pvc profila okomice okvira rama kod trostranog profila

Cutting of pvc profile frame mullion by tri-way profile

H (378.004) = H kom.1

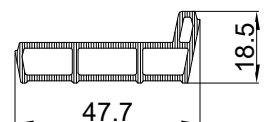
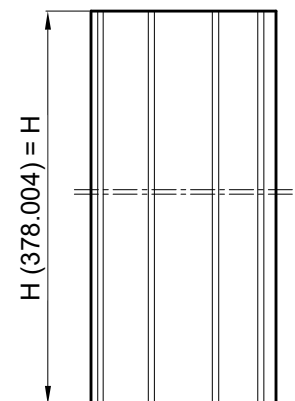
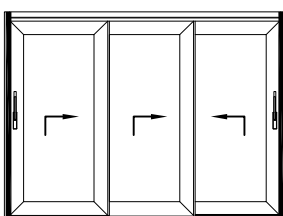
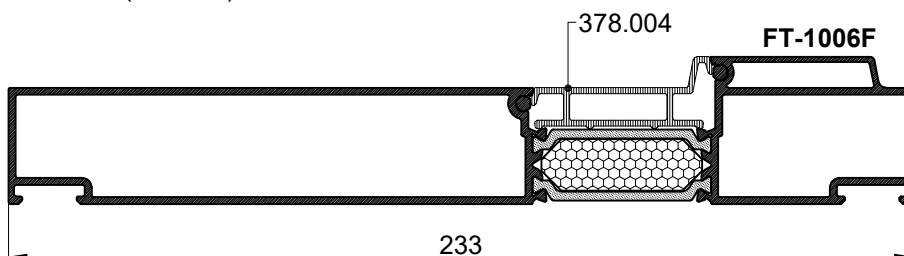

Obrada na pvc profilu za vijak 4.2x22 (DIN 7981),  
art.433.031 (dvostazno i trostazno)  
Processing on pvc profile for screw 4.2x22 (DIN 7981),  
art.433.031 (two-way and tri-way)

Obrada na pvc profilu za vijak 4.2x22 (DIN 7981),  
art.433.031 (trostazno)  
Processing on pvc profile for screw 4.2x22 (DIN 7981),  
art.433.031 (tri-way)

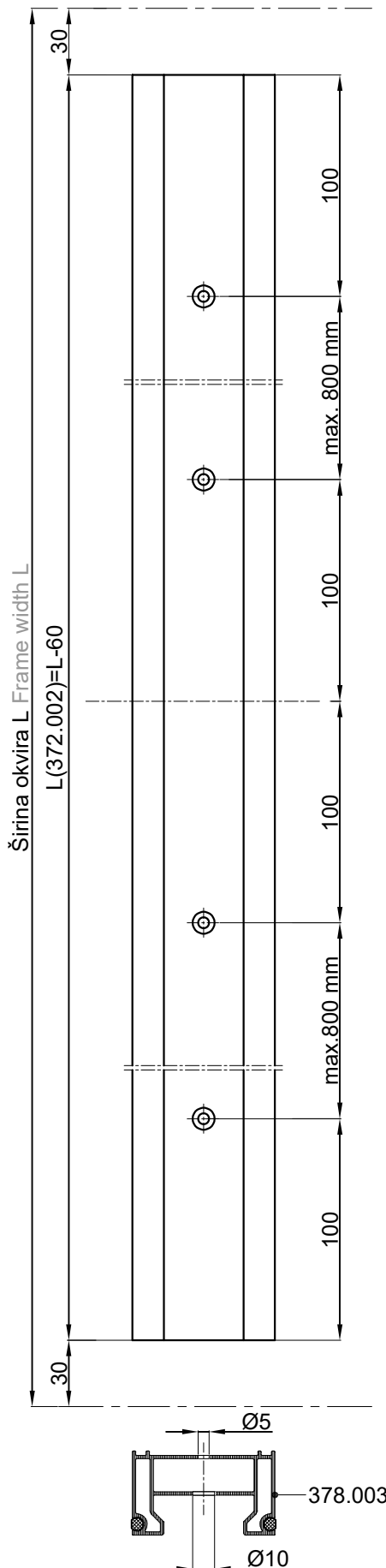
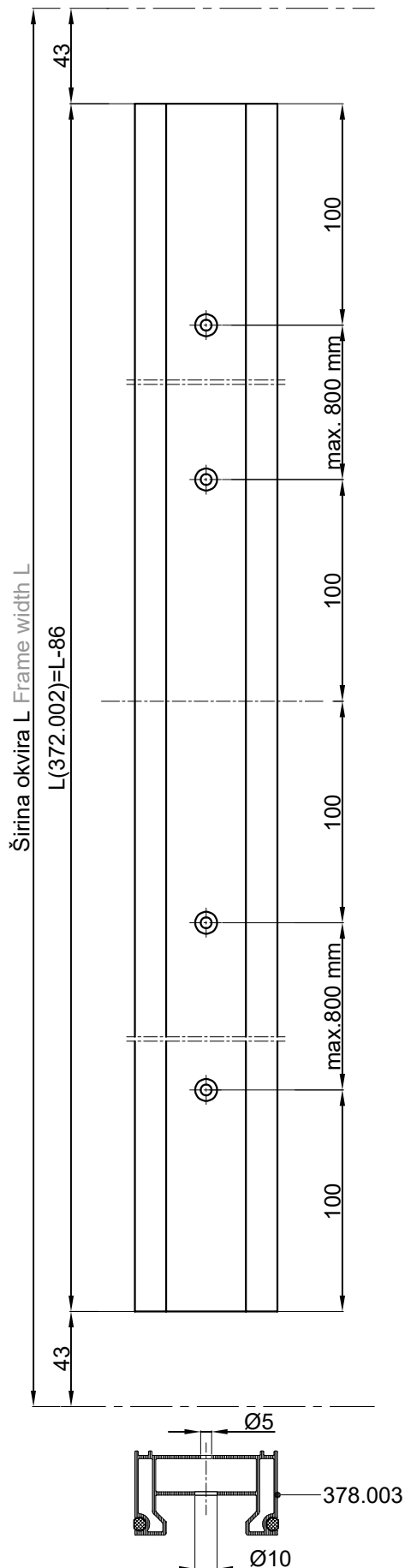

### Obrada profila krila za skriveni odvod kapljevina

- izvod kapljevina iz krila pomoću monodrain cjevčice 360.009
- obradu profila raditi glodalom ili svdlom  $\varnothing 10$  svakih 600 mm (250 mm od krajeva profila)

### Processing of sash profile for hidden drainage

- drainage from sash by monodrain tubule 360.009
- process profile with mill or bore  $\varnothing 10$  every 600 mm (250 mm from the end of profile)

### Obrada profila krila FT-1020F i FT-1022F Processing sash profile FT-1020F i FT-1022F

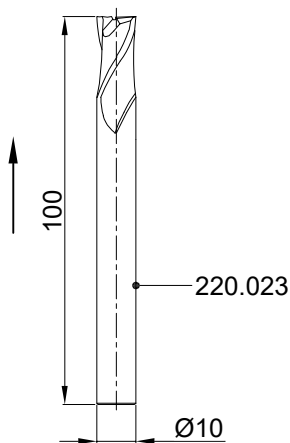
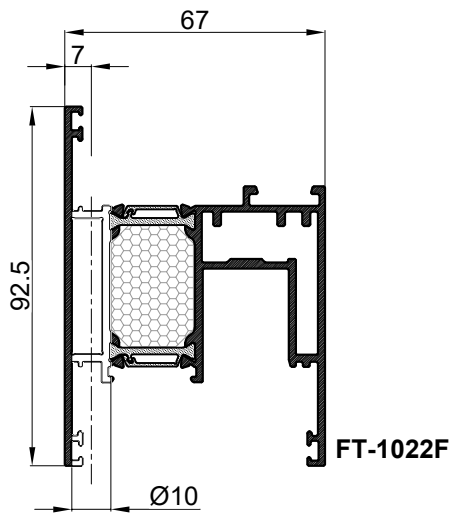
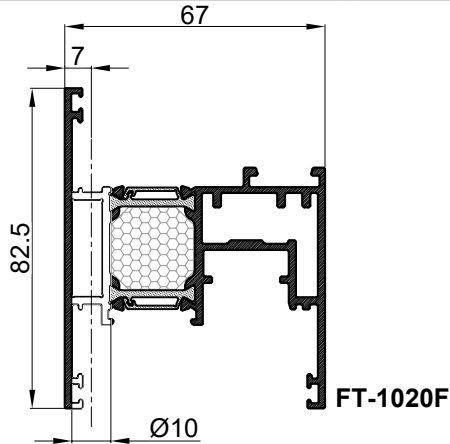

### Ugradnja monodrain cjevčice 360.009 Montage of monodrain tubule 360.009

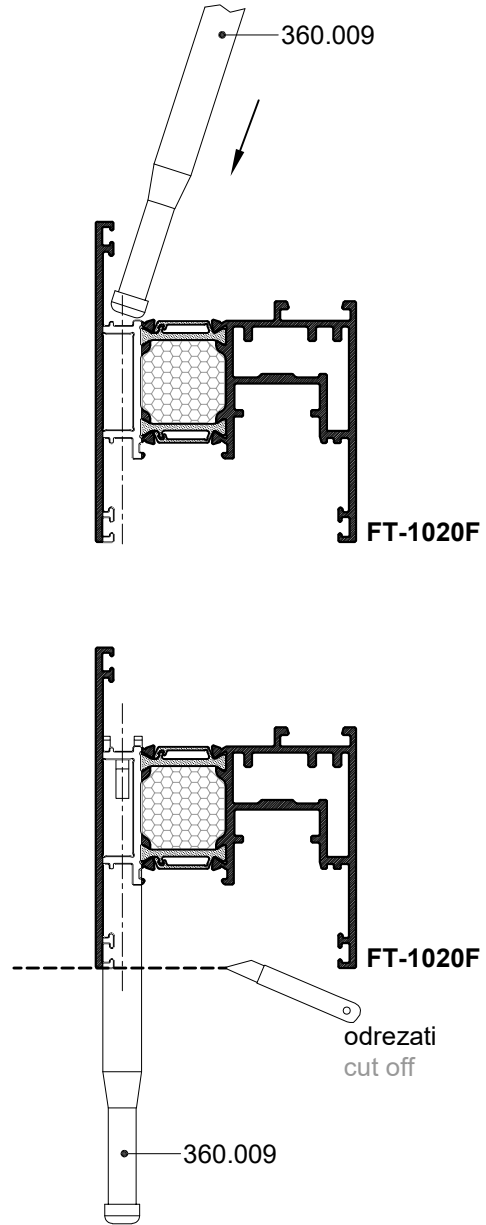

### Monodrain u sklopu Monodrain in the assembly

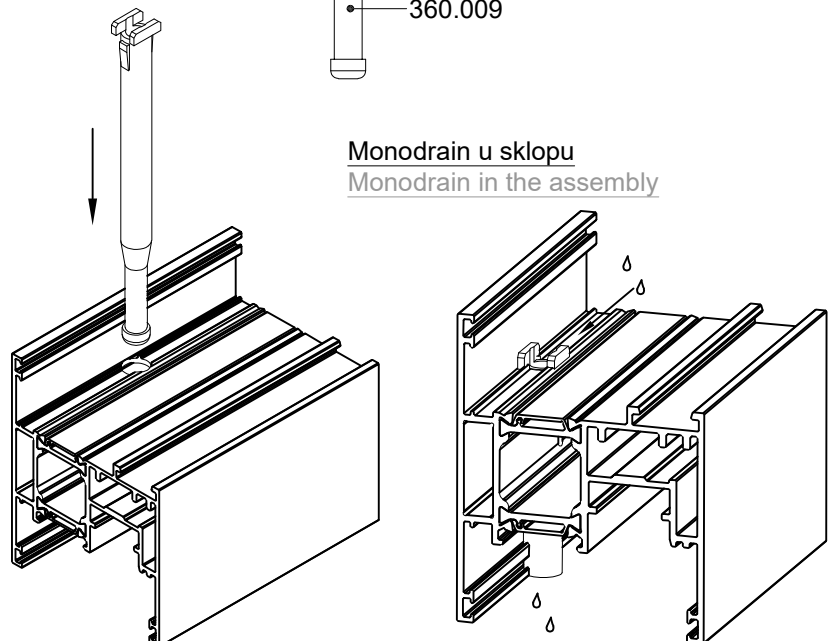

ODVOD KAPLJEVINA IZ PROFILA KRILA **FT-1020F** (pokretno krilo) I RAMA **FT-1001F**  
DRAINAGE FROM SASH PROFILE **FT-1020F** (moving sash) AND FRAME **FT-1001F**

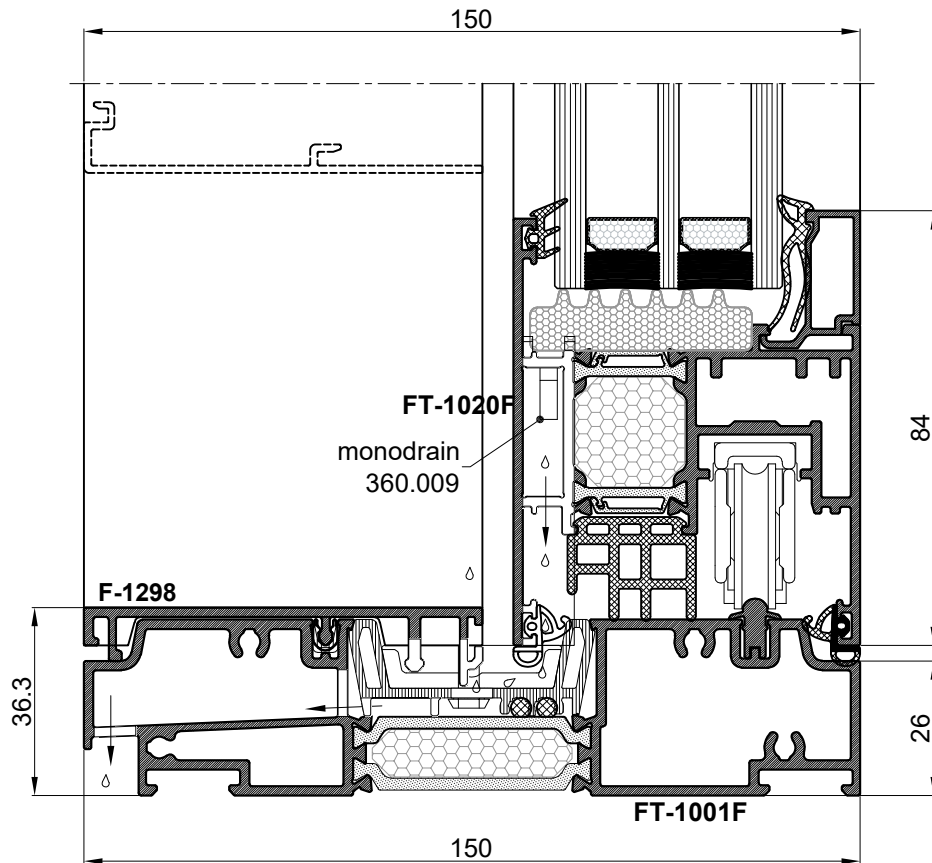

ODVOD KAPLJEVINA IZ PROFILA KRILA **FT-1020F** (fiksno krilo) I RAMA **FT-1001F**  
DRAINAGE FROM SASH PROFILE **FT-1020F** (fixed sash) AND FRAME **FT-1001F**

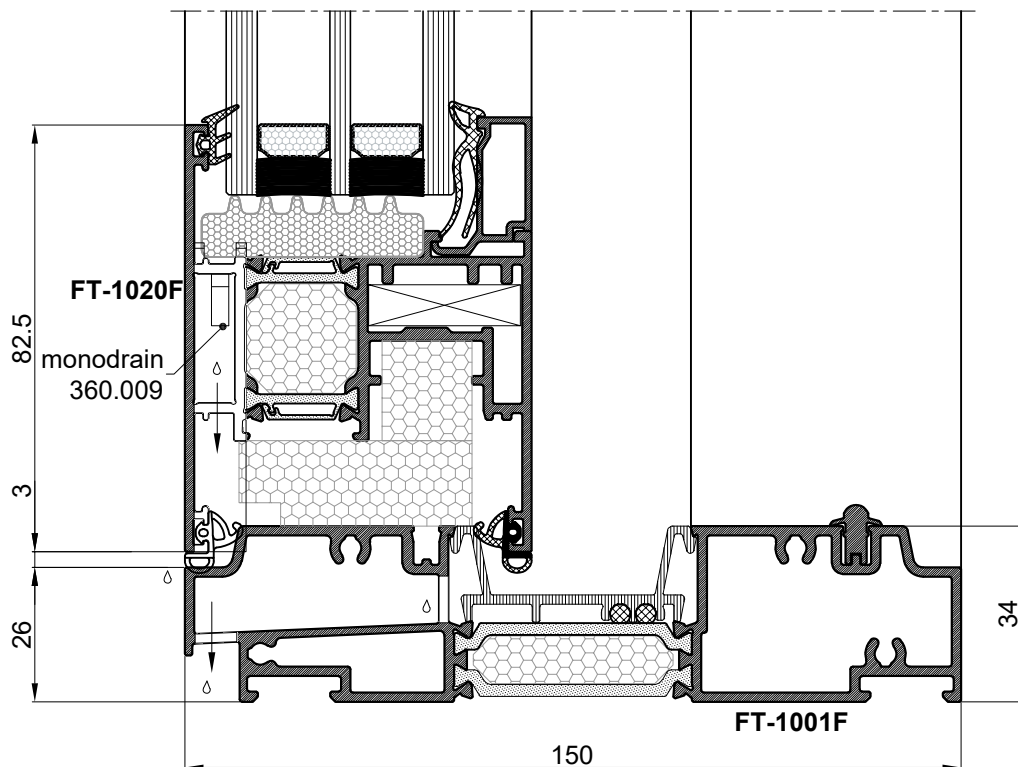



ODVOD KAPLJEVINA IZ PROFILA KRILA **FT-1020F** (pokretna krila) I RAMA **FT-1004F**  
DRAINAGE FOR SASH PROFILE **FT-1020F** (moving sash) AND FRAME **FT-1004F**

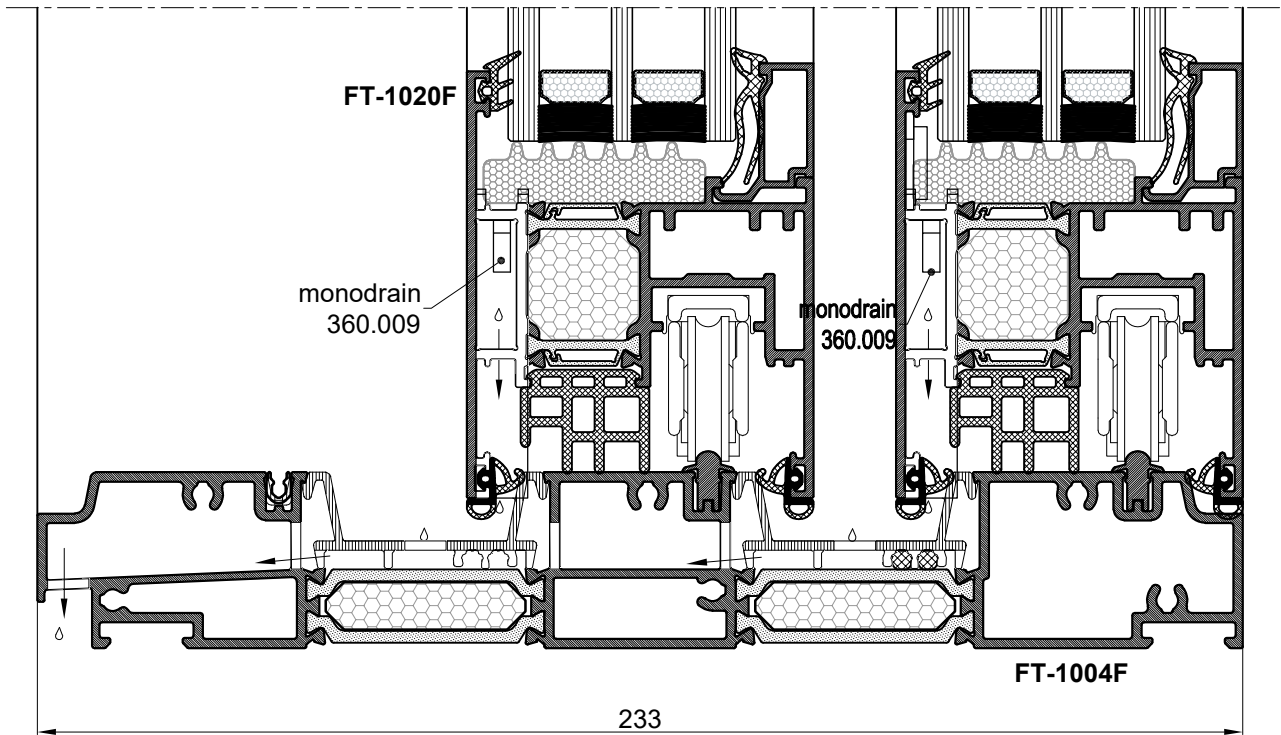

ODVOD KAPLJEVINA IZ PROFILA KRILA **FT-1020F** (fiksno krilo) I RAMA **FT-1004F**  
DRAINAGE FROM SASH PROFILE **FT-1020F** (fixed sash) AND FRAME **FT-1004F**

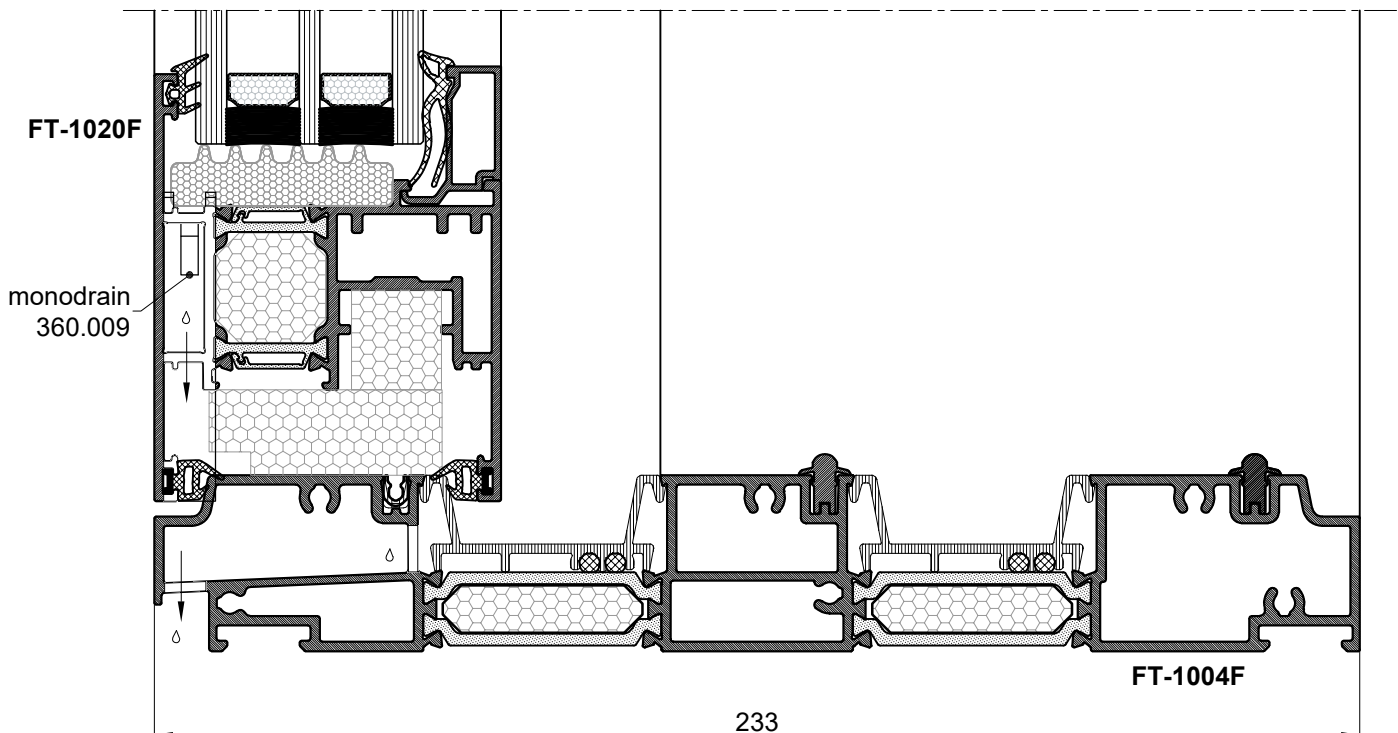

OBRADA PROFILA FT-1004F I PVC PROFILA 378.002 ZA ODVOD KAPLJEVINA  
 - obrada na glodalici vretenastim glodalom i glodalom za T žljebove  
 PROCESSING PROFILE FT-1004F I AND PVC PROFILE 378.002 FOR DRAINAGE  
 - processing on mill with end mill and T-slot milling cutter

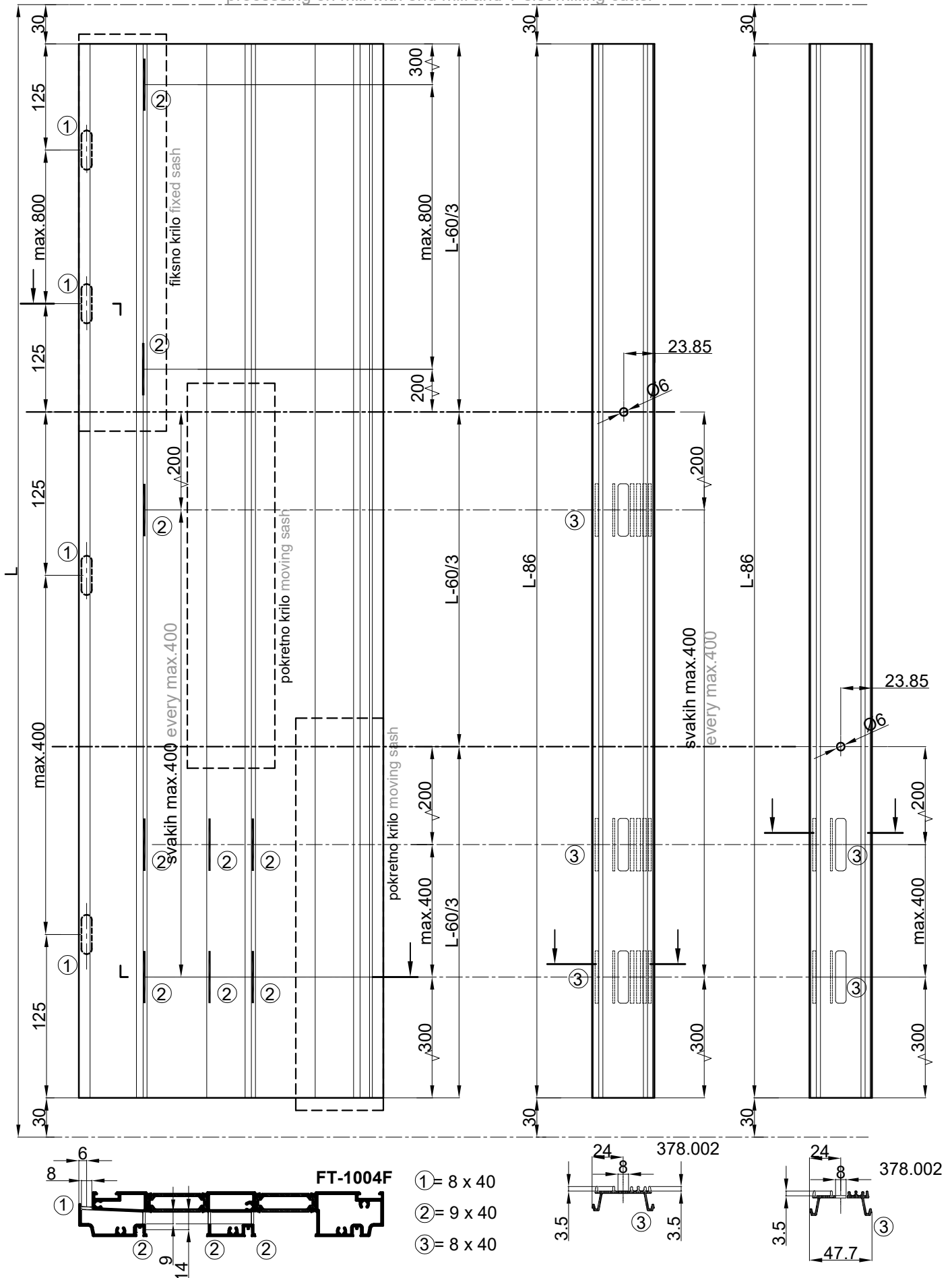

- Montaža dilatacijskih elemenata u pragu.
- Montage of the dilatation elements

- Dvostazna klizna stijena-PVC profil 372.001 fiksirati na sredini a na krajeve montirati elemente za dilataciju
- Trostazna klizna stijena krajeve-PVC profile 372.001 fiksirati na krajevima a dilatacijski element montirati na sredini
- Two-way sliding wall-PVC profile 372.001 fix in the middle and mount dilatation elements at the ends
- Three-way sliding wall, fix the ends of the PVC profile 372.001 at the ends and mount the expansion element in the middle

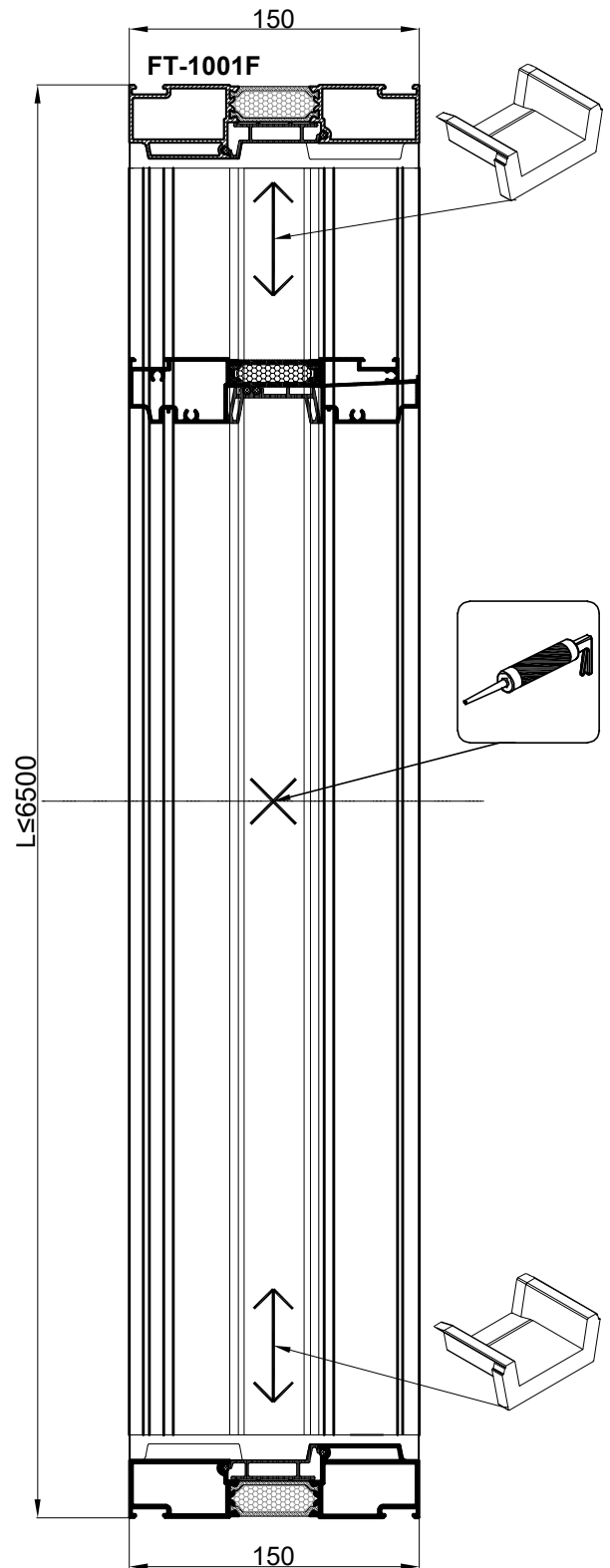
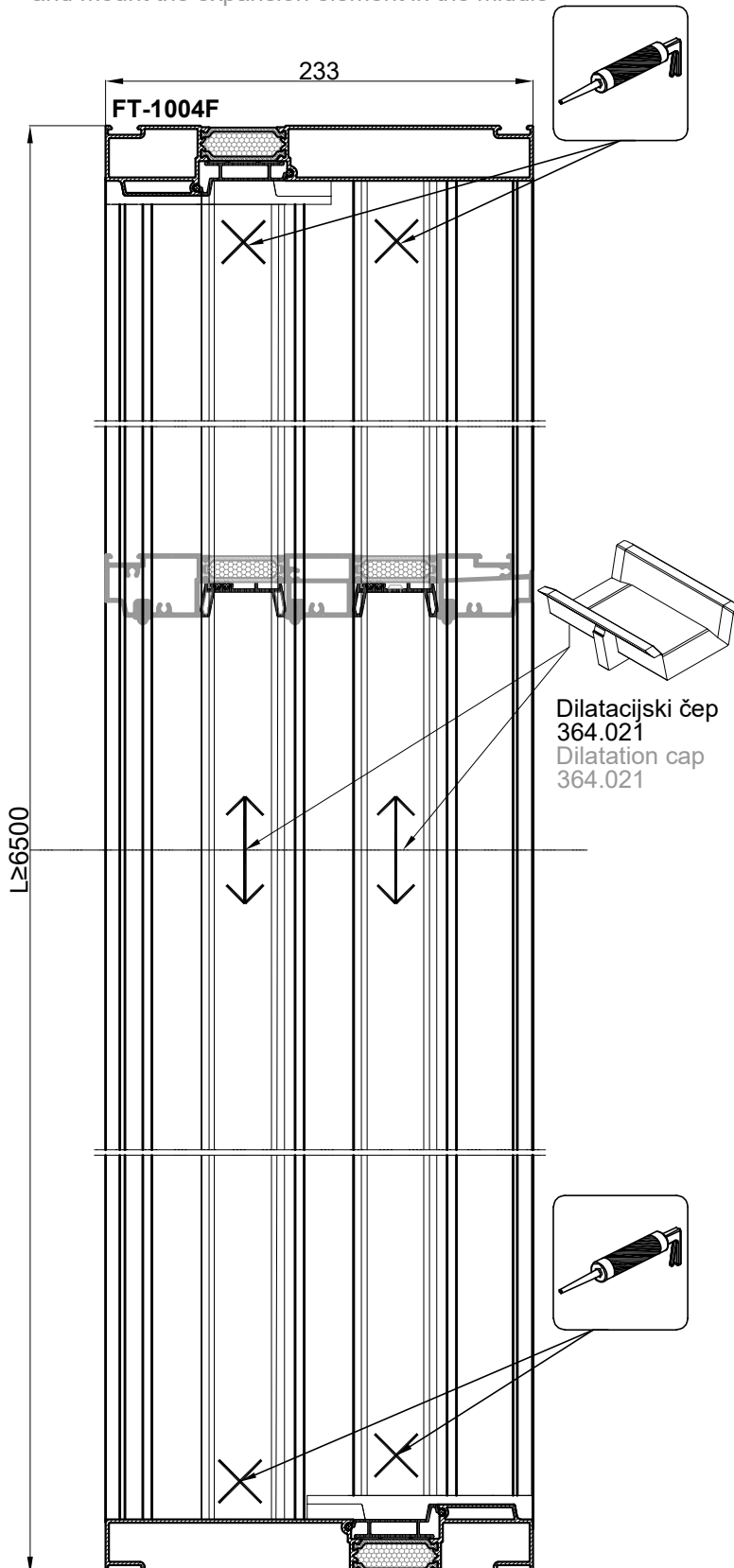
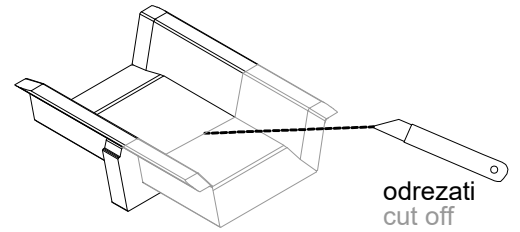

UGRADNJA I OBRADA AL.PROFILA FT-1030F S ČEPOM  
MONTAGE AND PROCESSING AL.PROFILE FT-1030F WITH CAP

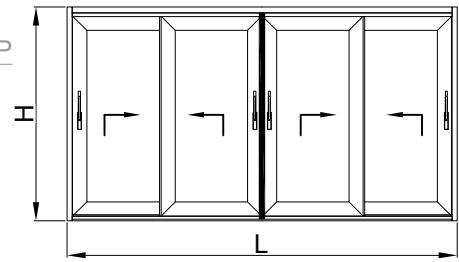

Obrada profila FT-1030F  
za ugradnju umetka 363.030  
-simetrična obrada  
Processing profile FT-1030F  
for mounting inserts 363.030  
-symmetrical processing

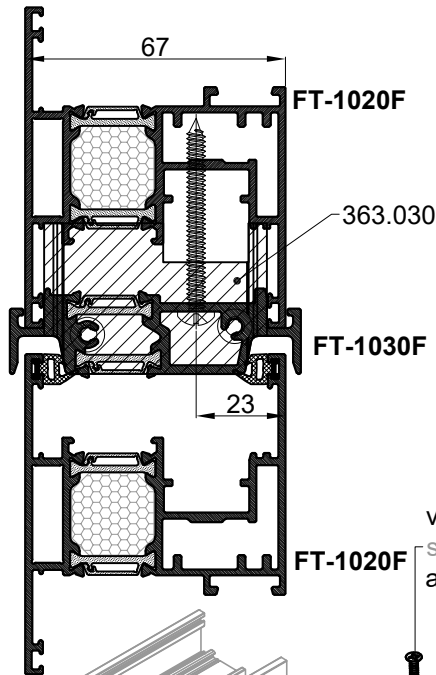

vijak 4.2x32 (DIN 7981)  
screw 4.2x32 (DIN 7981)  
art.433.033  
umetak 363.030  
insert 363.030  
usmjerivač krila  
sash guide  
373.078

-vijak 4.8x50  
screw 4.8x50  
(DIN 7981)  
art.433.049

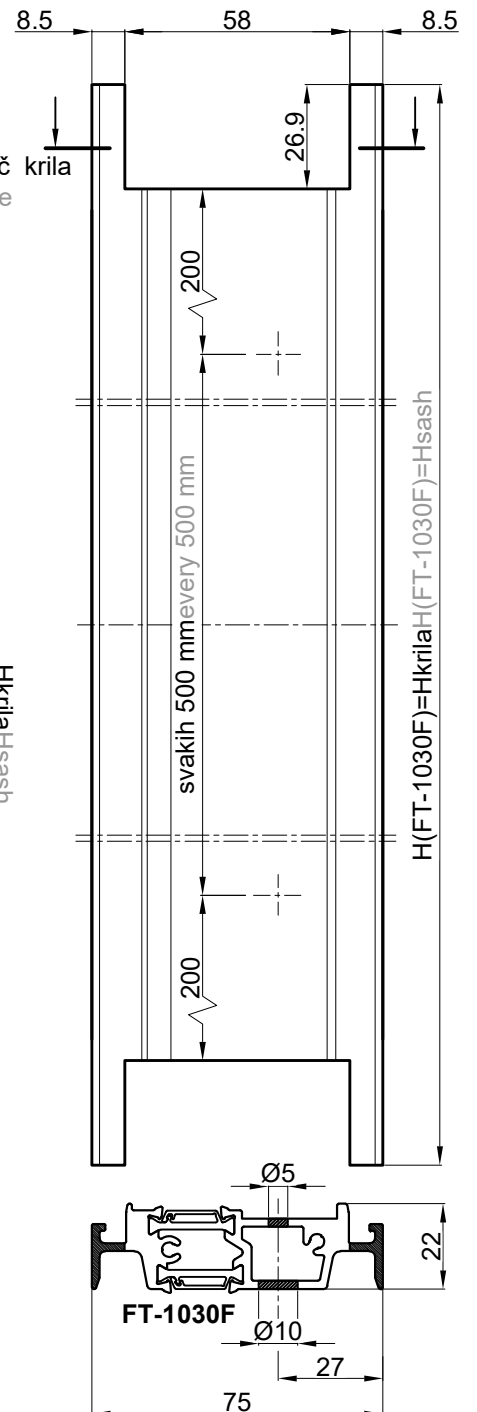
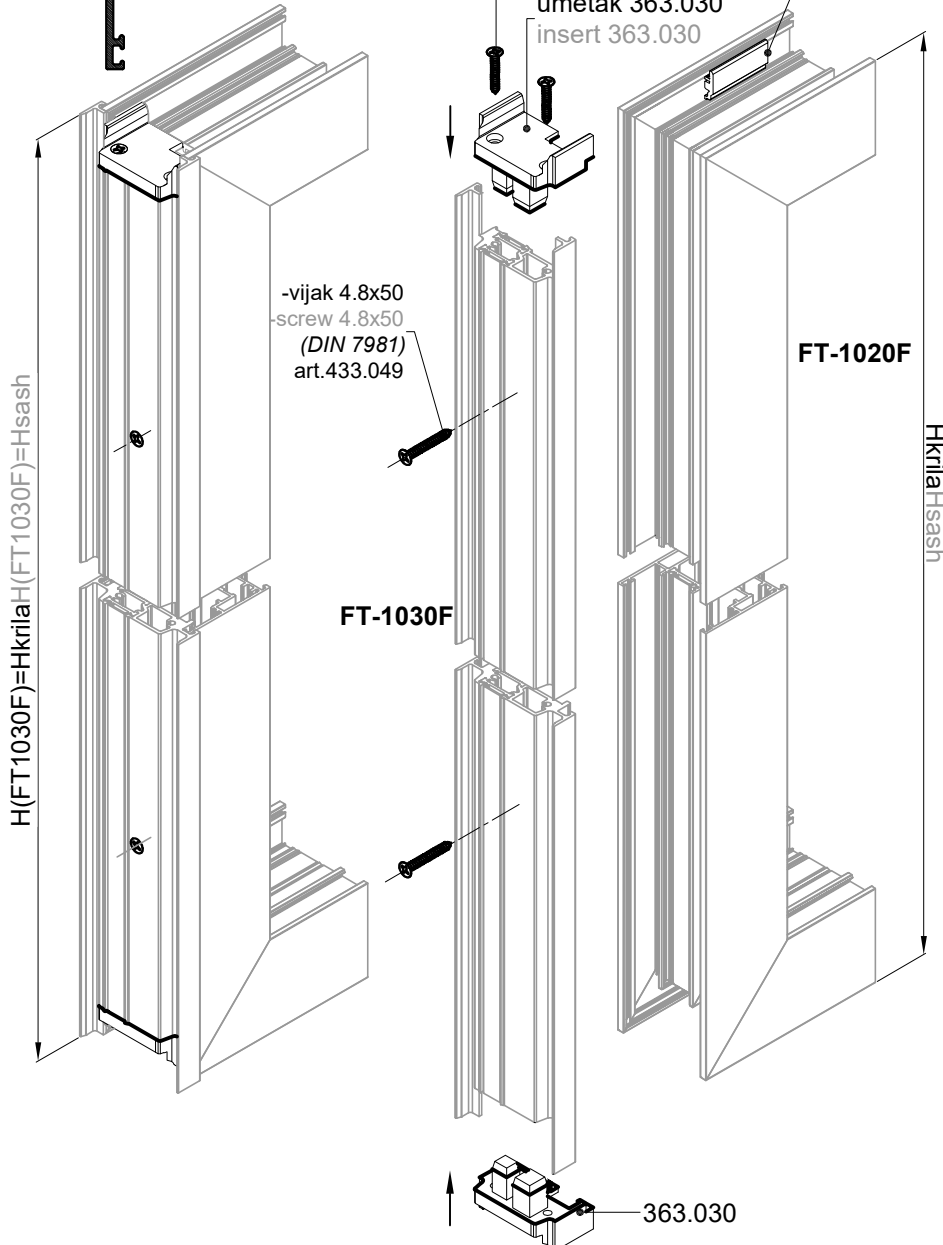

## MJERE REZANJA PROFILA ZA MASKIRANJE

1. F-1298 - profil vodoravni - dolje  
 $L(F-1298)=L/2-77$
2. F-1432 - profil vodoravni - gore  
 $L(F-1432)=L/2-77$
3. F-1433 - profil okomiti na sastavu krila  
 $H(F-1433)=H-84$
4. F-1434 - profil okomiti prema ramu  
 $H(F-1434)=H-100$

## CUTTING LENGTHS OF MASKING PROFILE

1. F-1298 - horizontal profile - down  
 $L(F-1298)=L/2-77$
2. F-1432 - horizontal profile - up  
 $L(F-1432)=L/2-77$
3. F-1433 - vertical profile on the sash joint  
 $H(F-1433)=H-84$
4. F-1434 - vertical profile towards frame  
 $H(F-1434)=H-100$

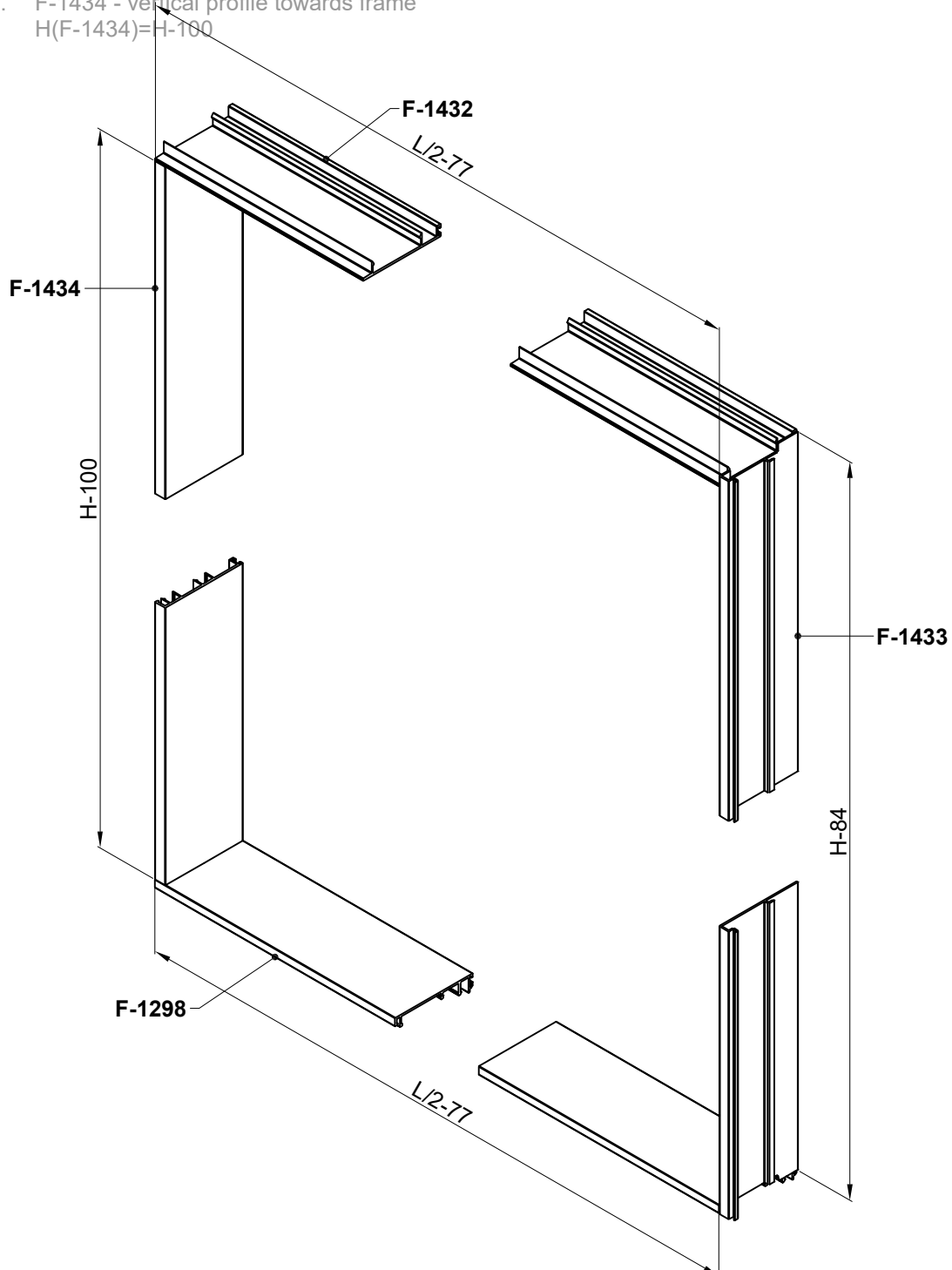
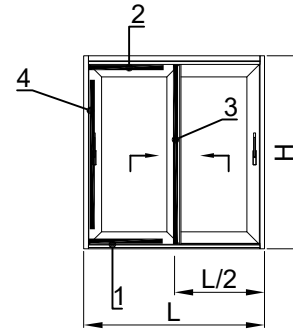

### UGRADNJA PROFILA F-1434 NA PROFIL FT-1002F (KLIPSANJEM) MOUNTING PROFILE F-1434 ON PROFILE FT-1002F (CLIPPING)

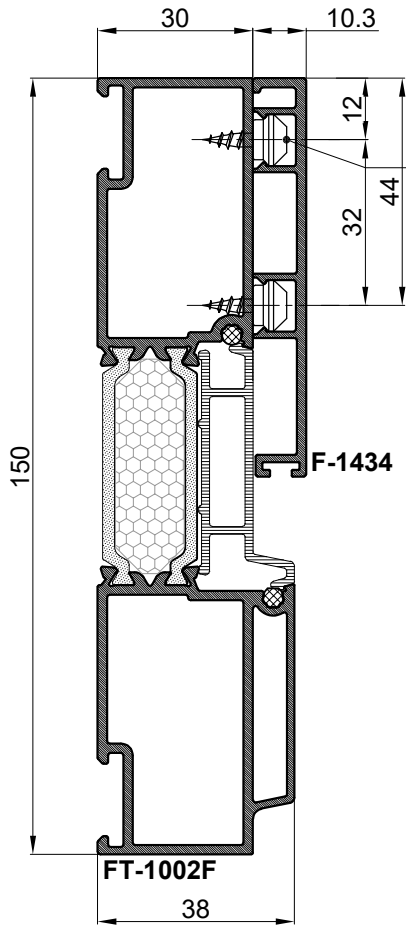

433.204-  
vijak za klipsanje  
screw for clipping

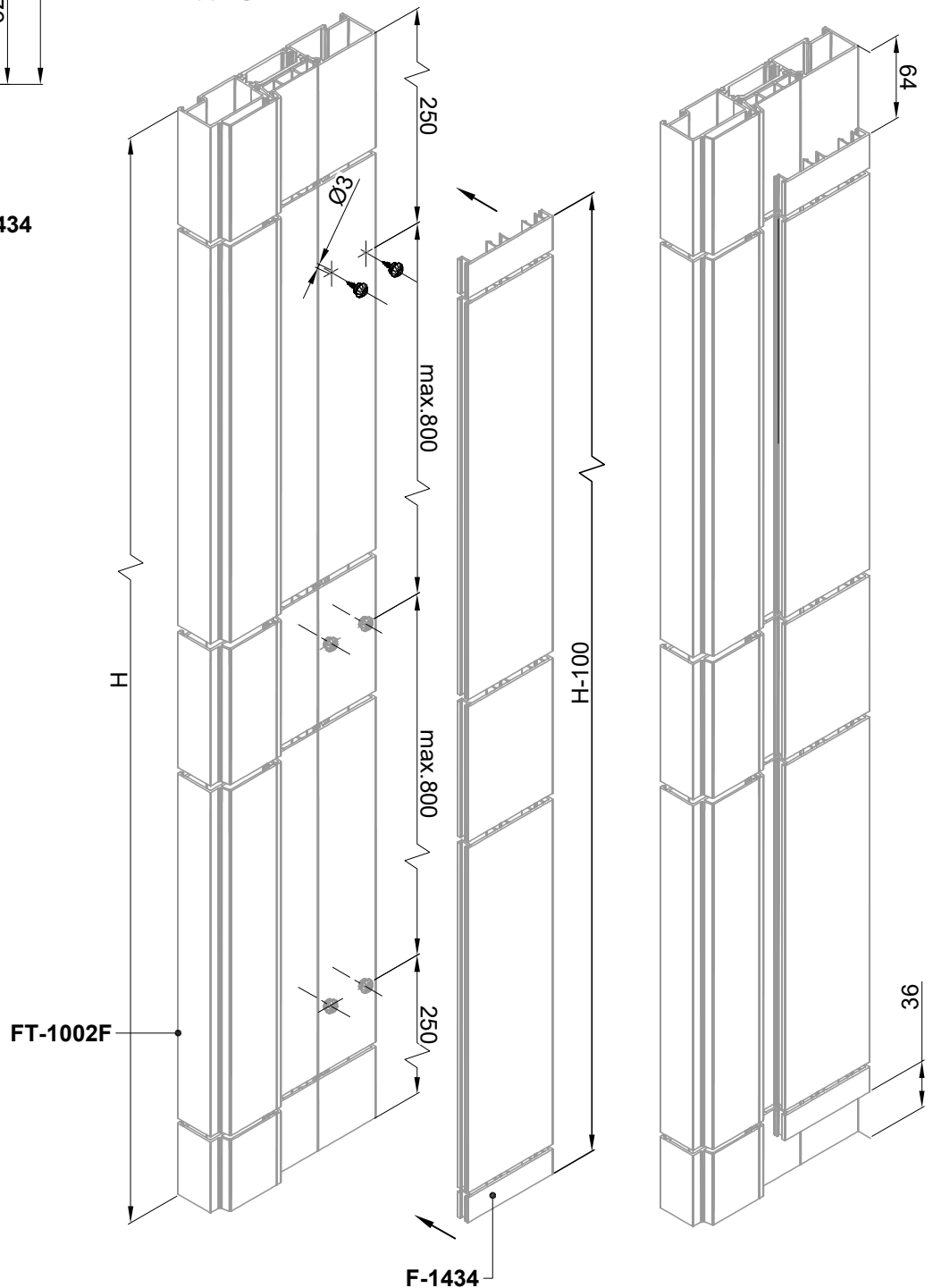
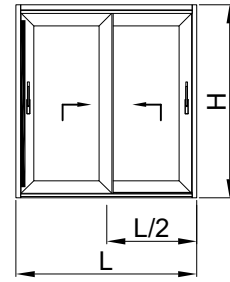

OBRADA ZA BRAVU Atrium Alu-HS 200 (Hautau)

-obrada na glodalici vretenastim glodalom

-za krilo FT-1022F

PROCESSING FOR ESPAGNOLETTE Atrium Alu-HS 200 (Hautau)

-processing on mill with end mill

-for sash FT-1022F

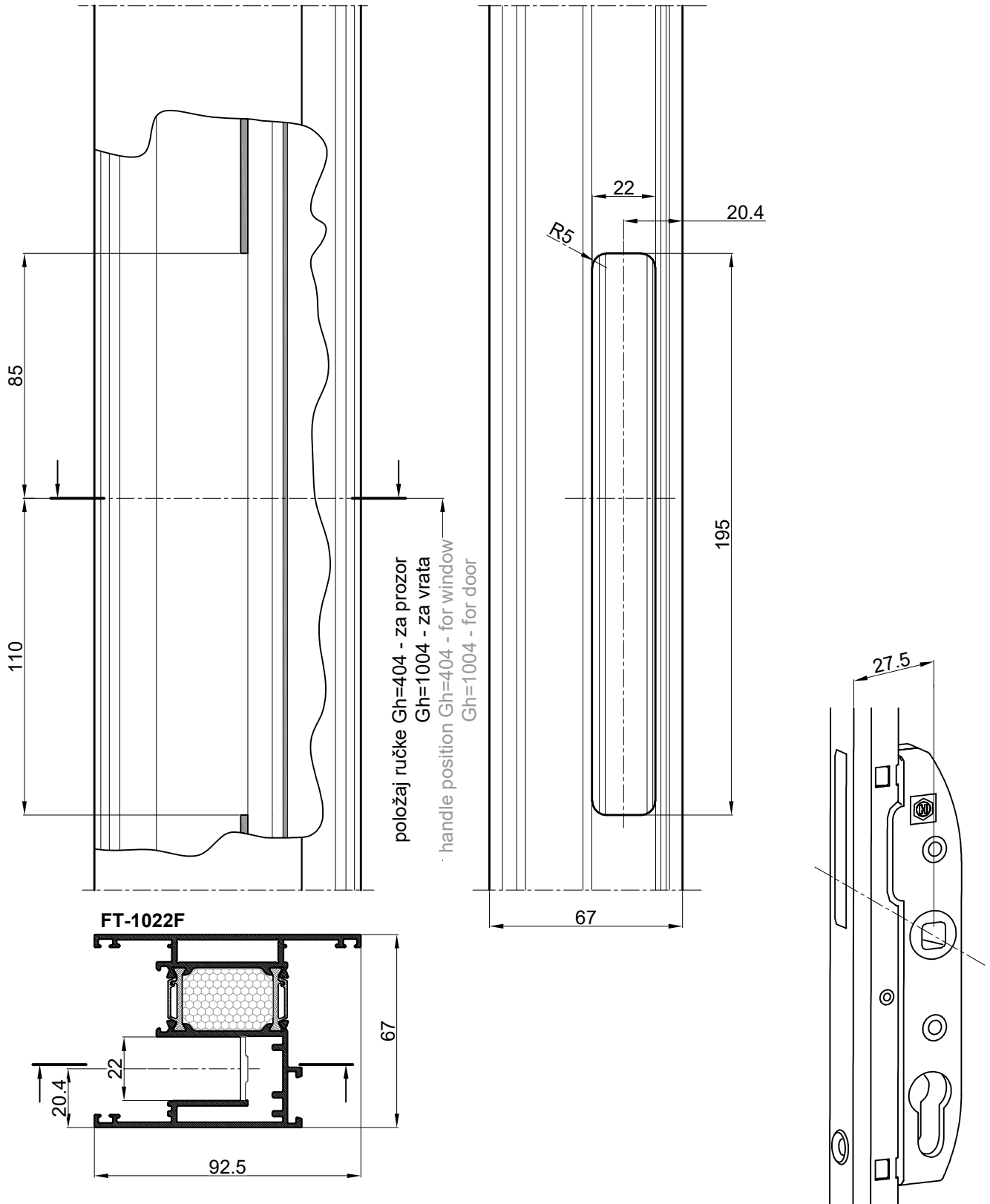

- za bravu Atrium Alu-HS 200 (Hautau)  
- for espag. Atrium Alu-HS 200 (Hautau)

OBRADA PROFILA FT-1022F ZA RUČKU 108.007, Hautau, za HS 200  
PROCESSING PROFILE FT-1022F FOR HANDLE 108.007, Hautau, za HS 200

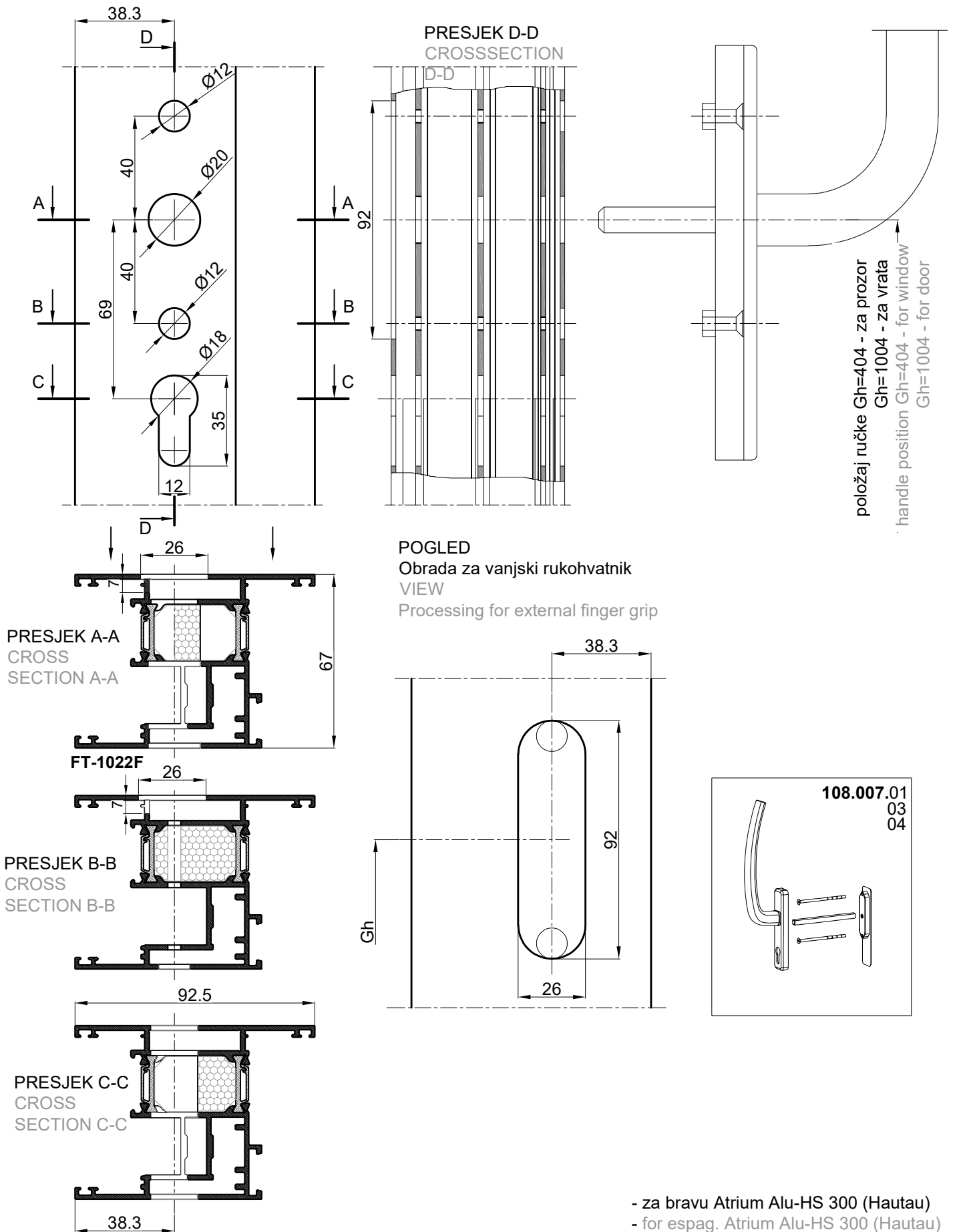

OBRADA PROFILA FT-1020F ZA RUČKU 108.006, Hautau  
PROCESSING PROFILE FT-1022F FOR HANDLE 108.006, Hautau

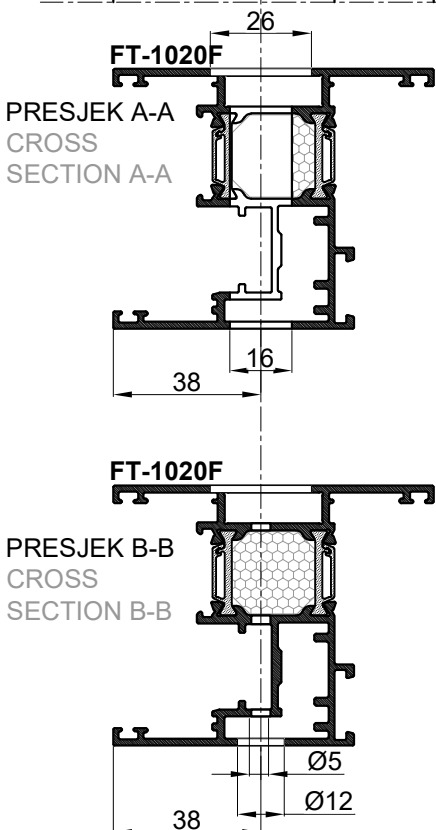
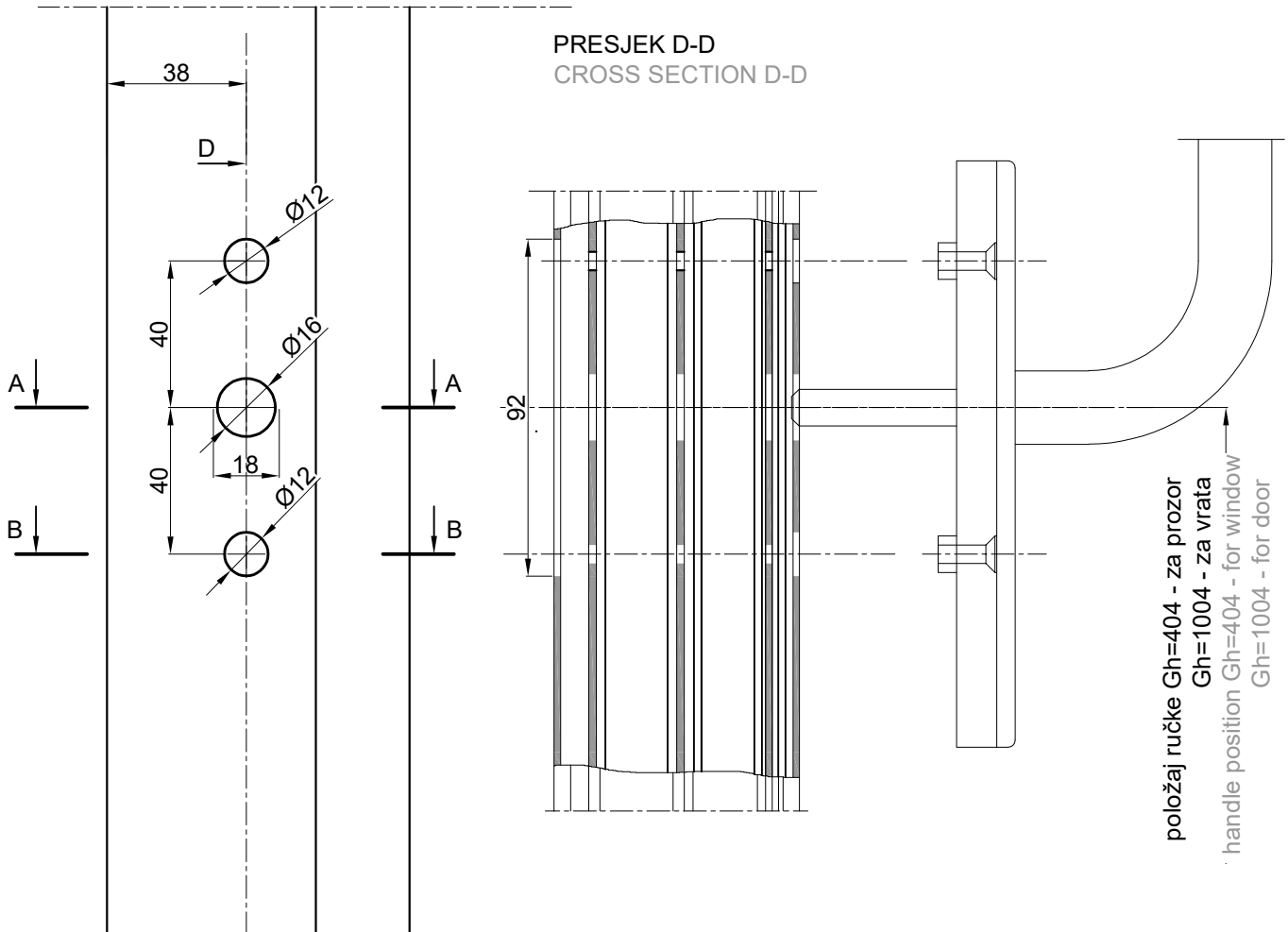

POGLED  
Obrada za vanjski rukohvatnik  
VIEW  
Processing for external finger grip

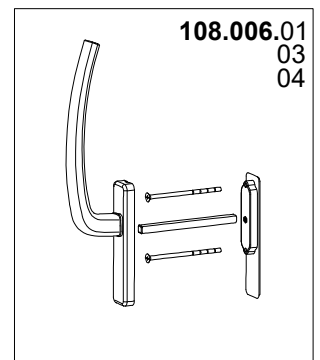
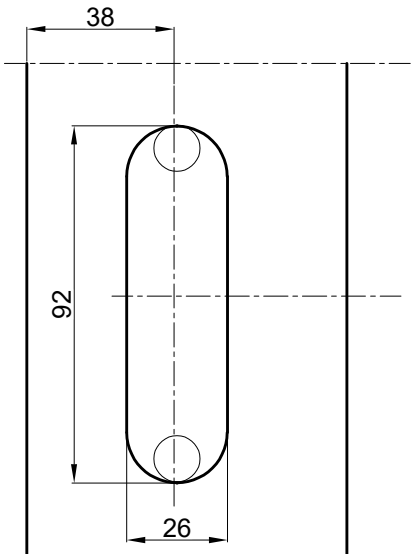

- za bravu Atrium Alu-HS 200 (Hautau)  
- for espag. Atrium Alu-HS 200 (Hautau)

OBRADA ZA BRAVU Atrium Alu-HS 200 (Hautau)

-obrada na glodalici vretenastim glodalom

-za krilo FT-1020F

PROCESSING FOR ESPAGNOLETTE Atrium Alu-HS 200 (Hautau)

-processing on mill with end mill

-for sash FT-1020F

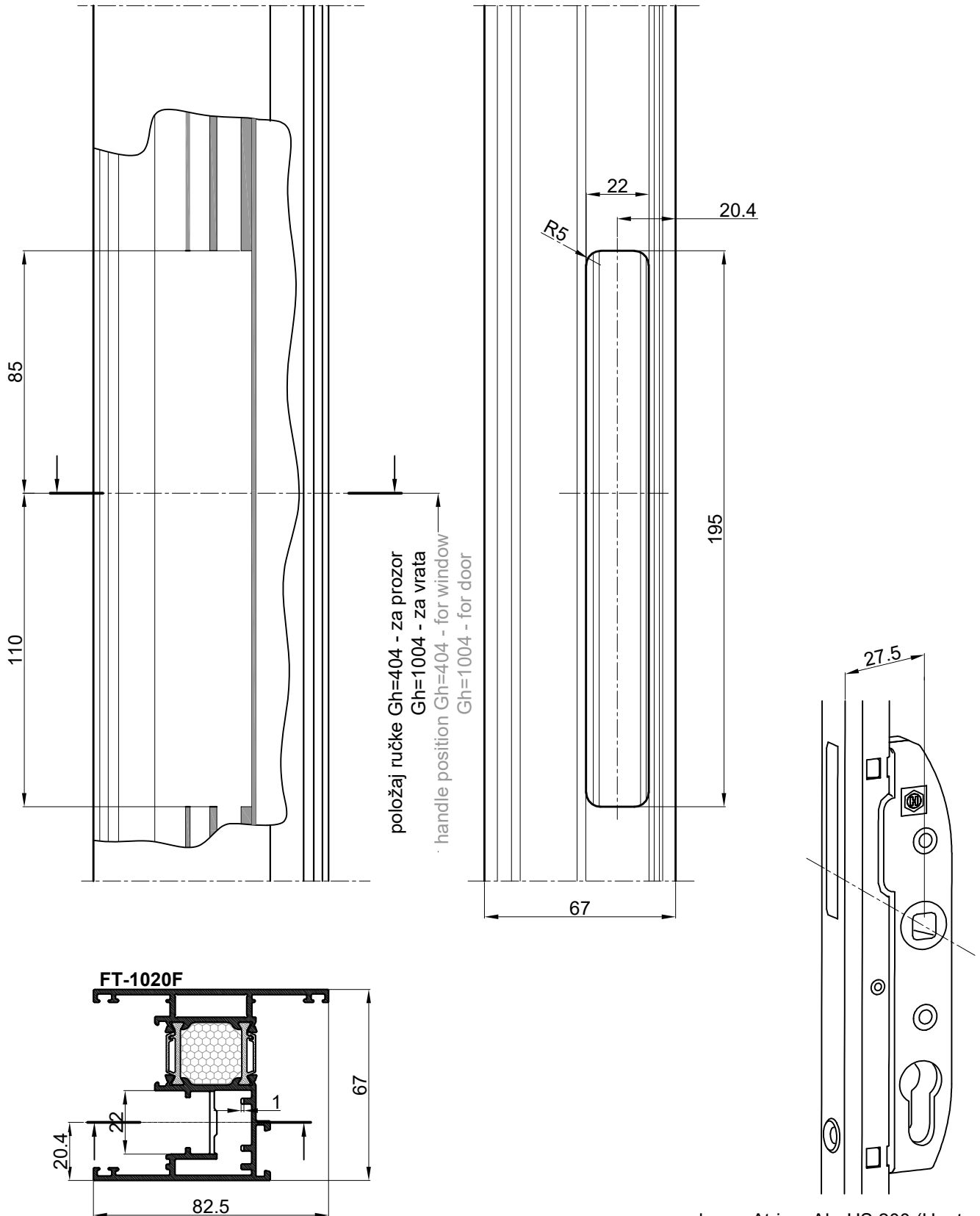

- za bravu Atrium Alu-HS 200 (Hautau)  
- for espag. Atrium Alu-HS 200 (Hautau)

OBRADA ZA BRAVU Atrium Alu-HS 330 (Hautau)

- obrada na glodalici vretenastim glodalom za krilo FT-1022F

PROCESSING FOR ESPAGNOLETTE Atrium Alu-HS 330 (Hautau)

- processing on mill with end mill for sash FT-1022F

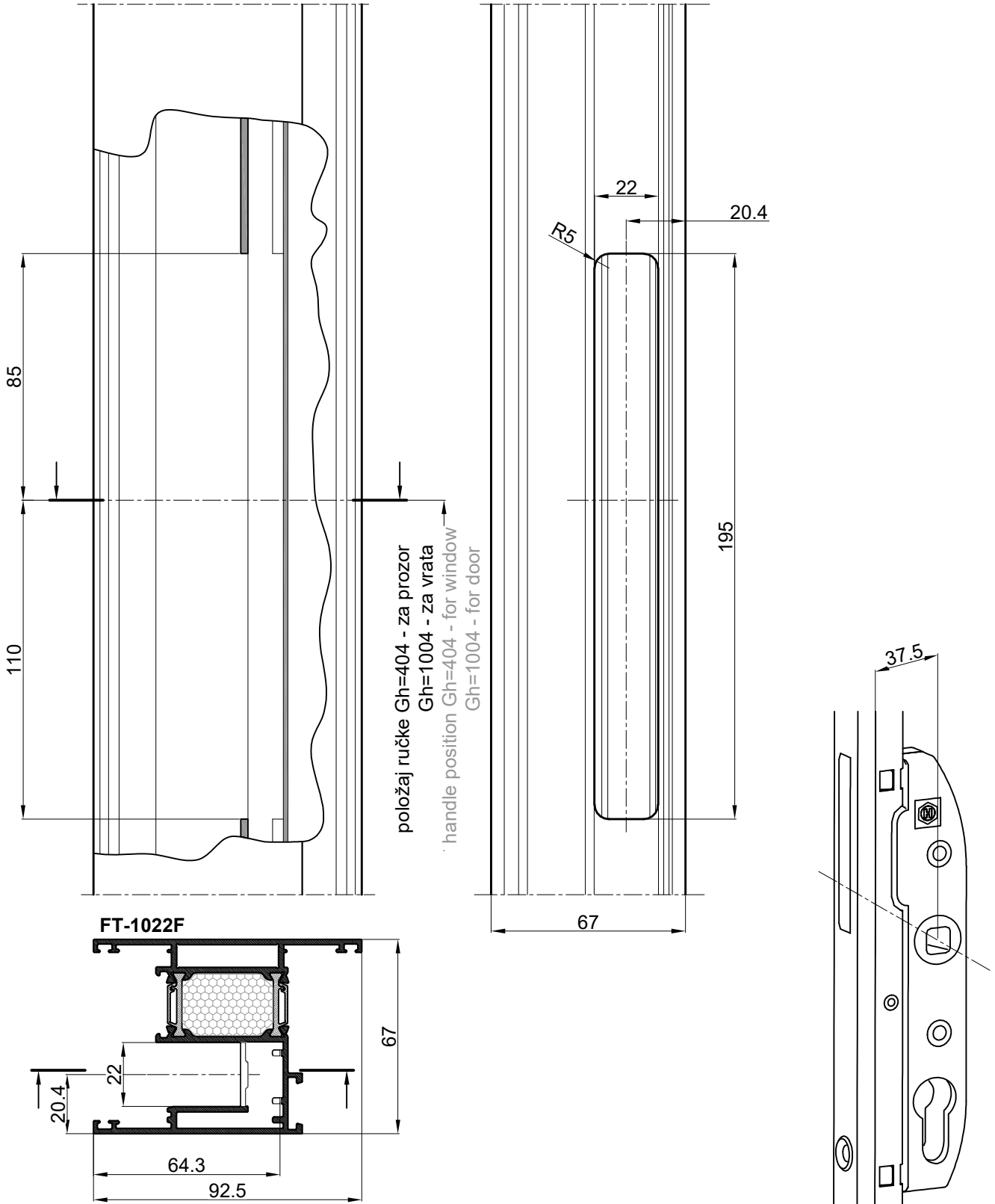

brava Atrium Alu-HS 330  
espag. Atrium Alu-HS 330

OBRADA PROFILA FT-1022F ZA RUČKU 108.008, Hautau  
PROCESSING PROFILE FT-1022F FOR HANDLE 108.008, Hautau

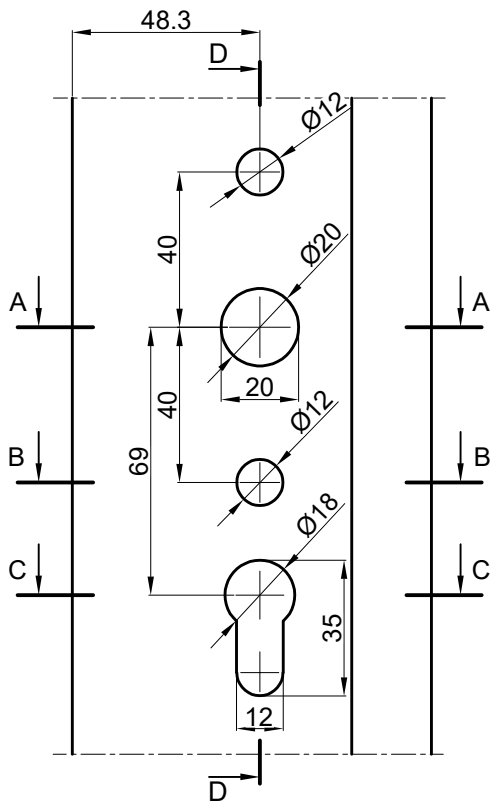

PRESJEK D-D  
CROSS SECTION D-D

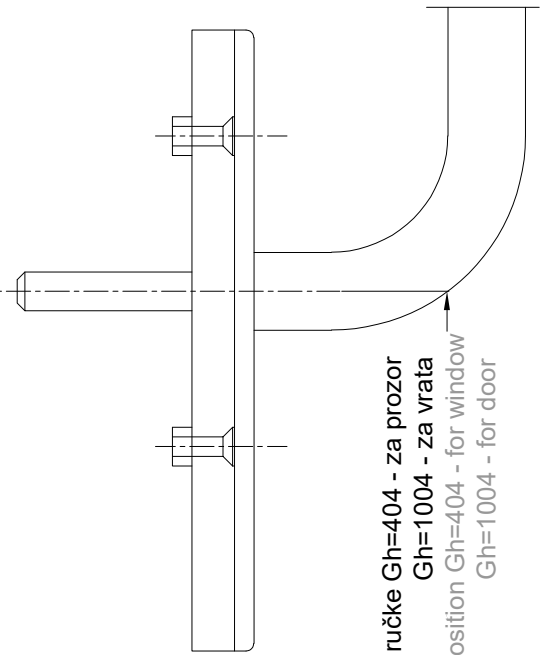
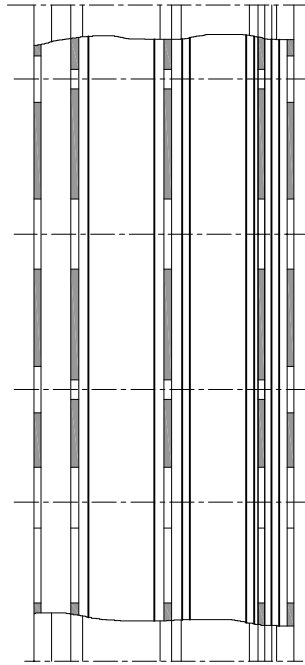

PRESJEK A-A  
CROSS SECTION A-A

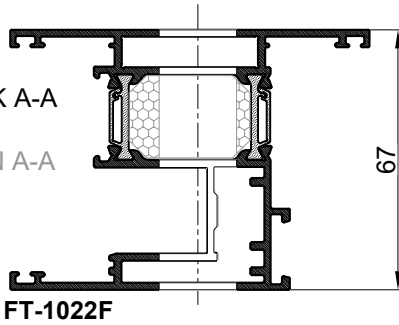

PRESJEK B-B  
CROSS SECTION B-B

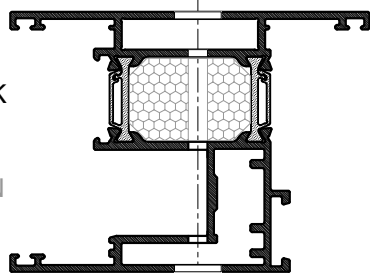

PRESJEK C-C  
CROSS SECTION C-C

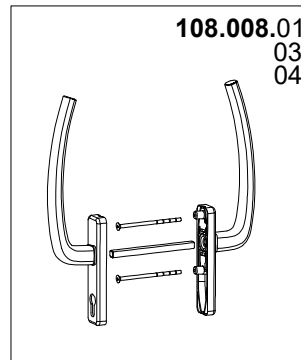
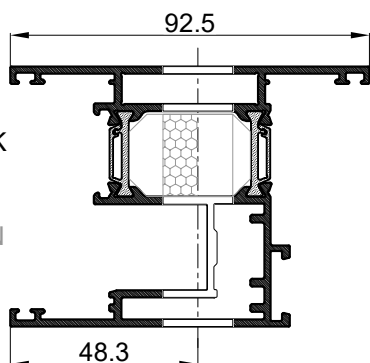

- za bravu Atrium Alu-HS 330 (Hautau)  
- for espag. Atrium Alu-HS 330 (Hautau)

OBRADA PROFILA FT-1022F ZA RUČKU 108.001, Hautau  
PROCESSING PROFILE FT-1022F FOR HANDLE 108.001, Hautau

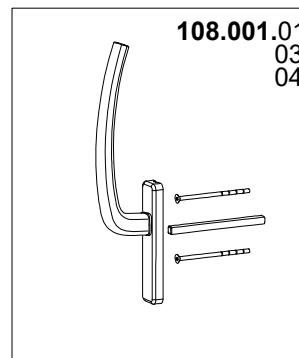
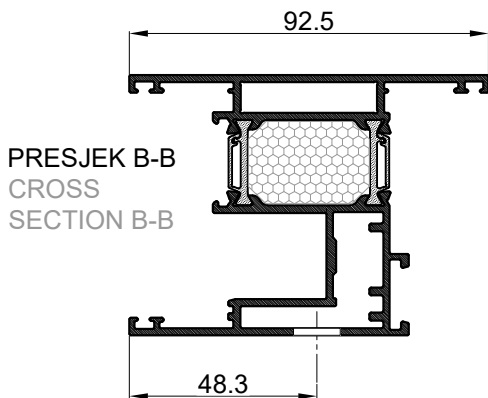
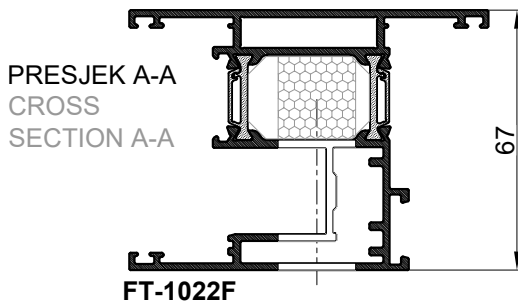
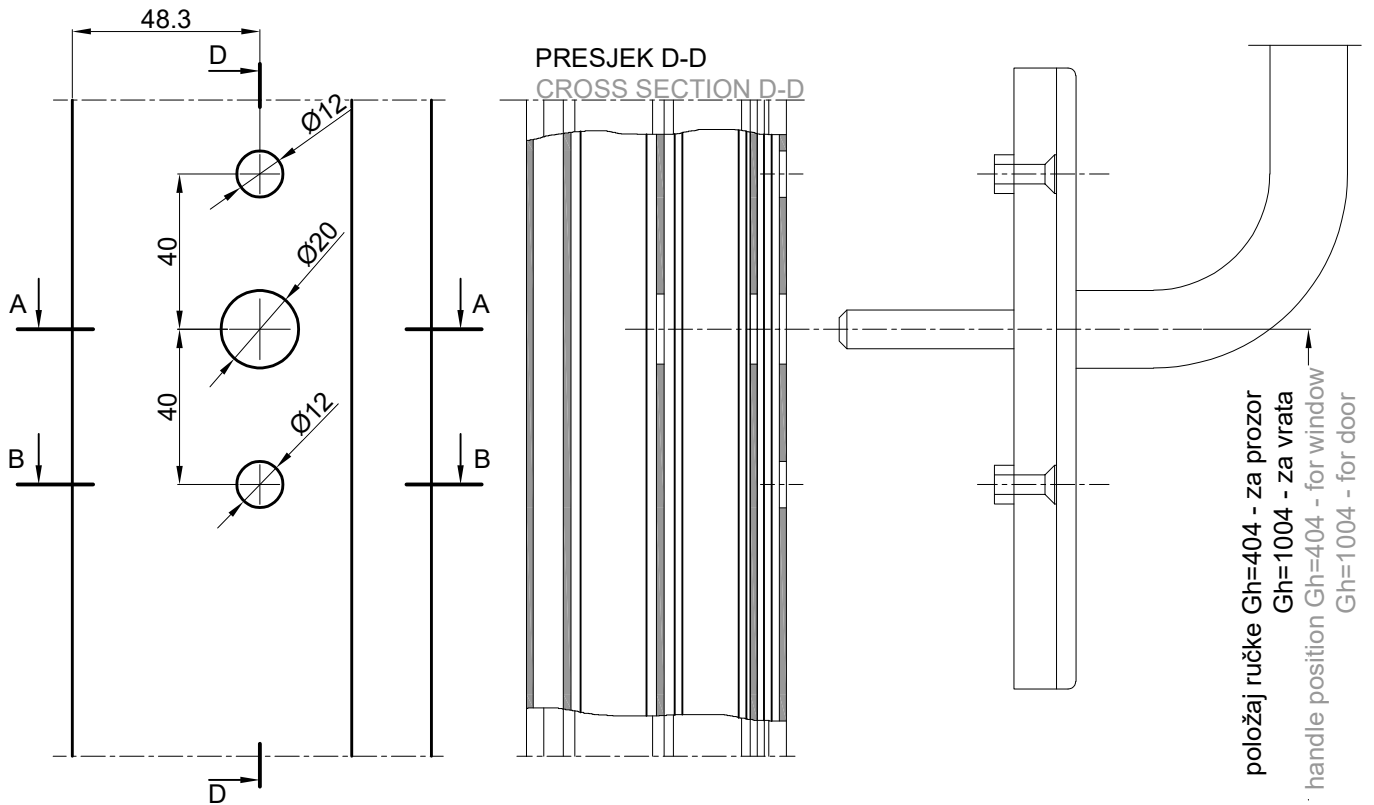

- za bravu Atrium Alu-HS 330 (Hautau)  
- for espag. Atrium Alu-HS 330 (Hautau)

OBRADA PROFILA FT-1022F ZA RUČKU 108.007, Hautau  
PROCESSING PROFILE FT-1022F FOR HANDLE 108.007, Hautau

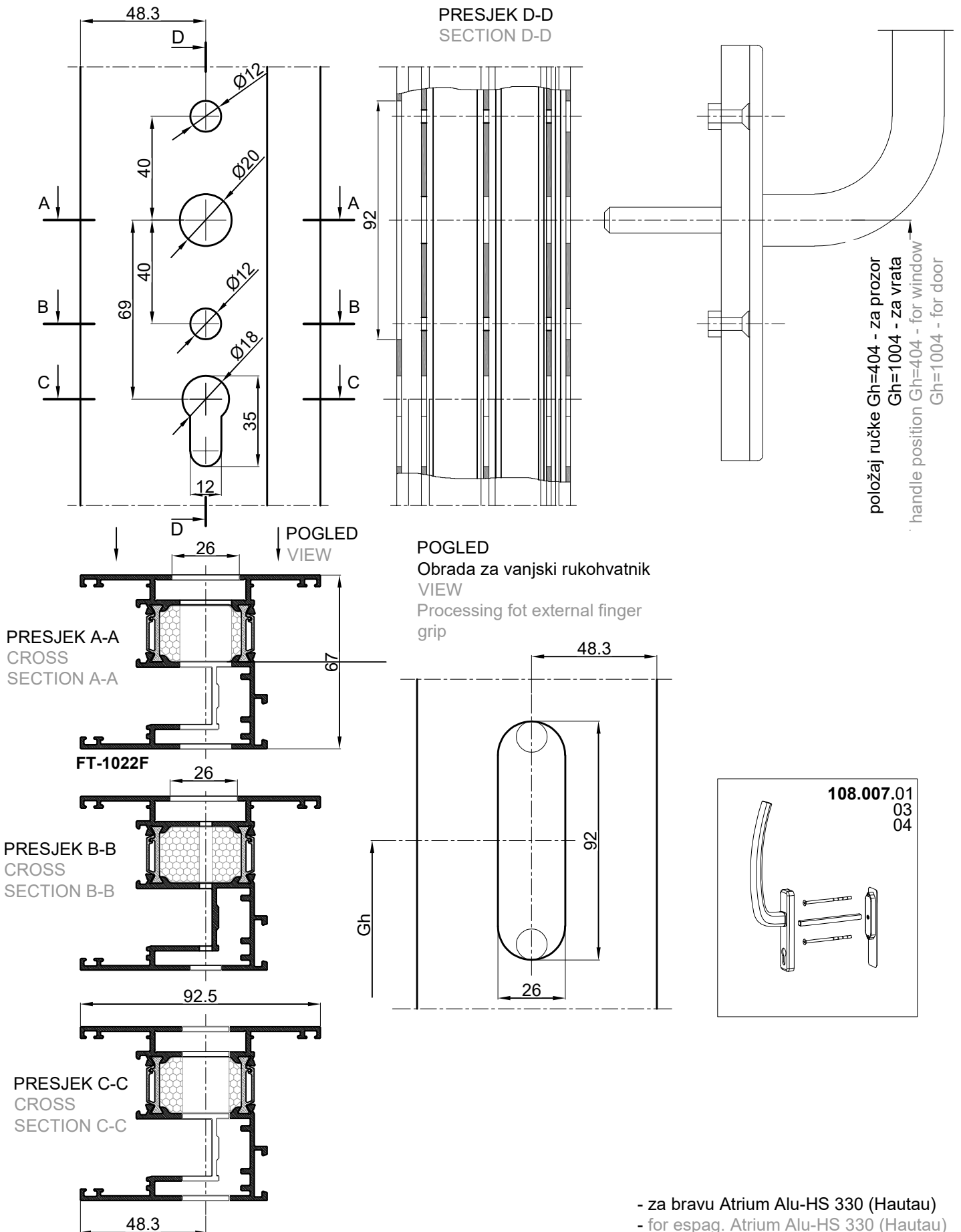

OBRADA PROFILA FT-1022F ZA RUČKU 108.006, Hautau  
PROCESSING PROFILE FT-1022F FOR HANDLE 108.006, Hautau

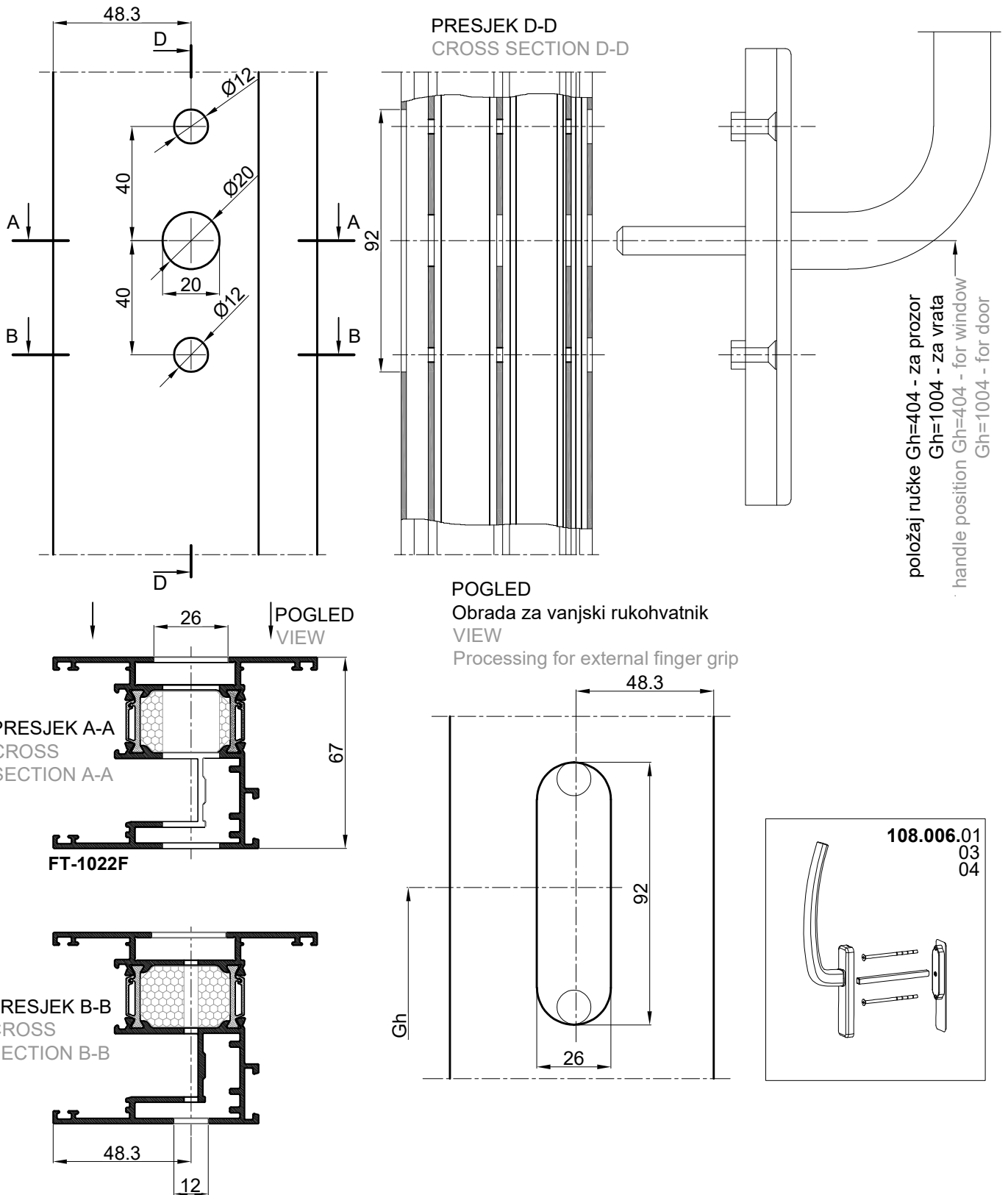

- za bravu Atrium Alu-HS 330 (Hautau)  
- for espag. Atrium Alu-HS 330 (Hautau)

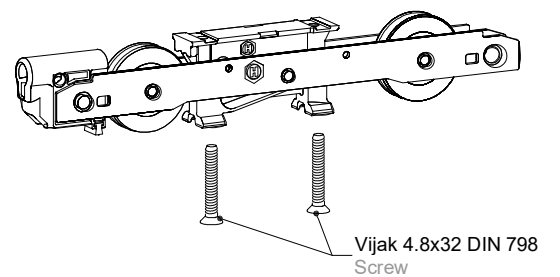
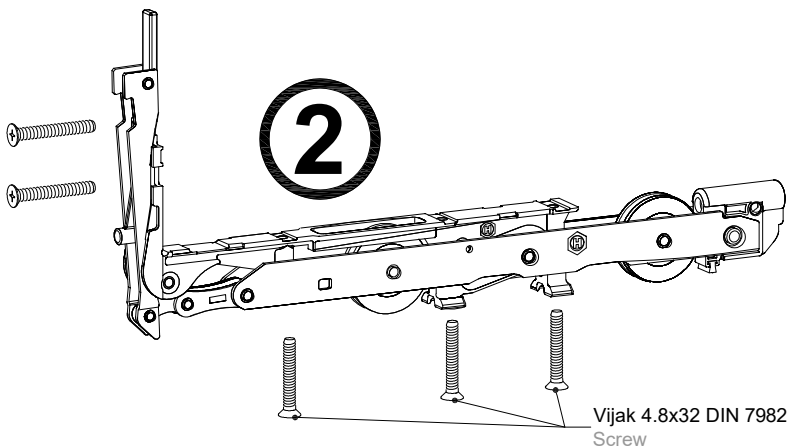
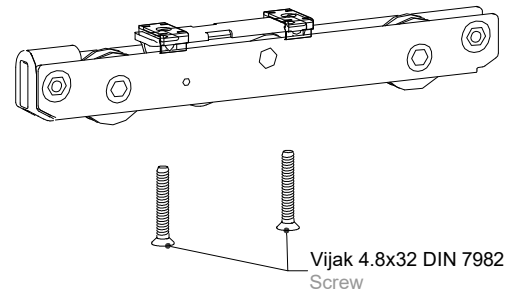
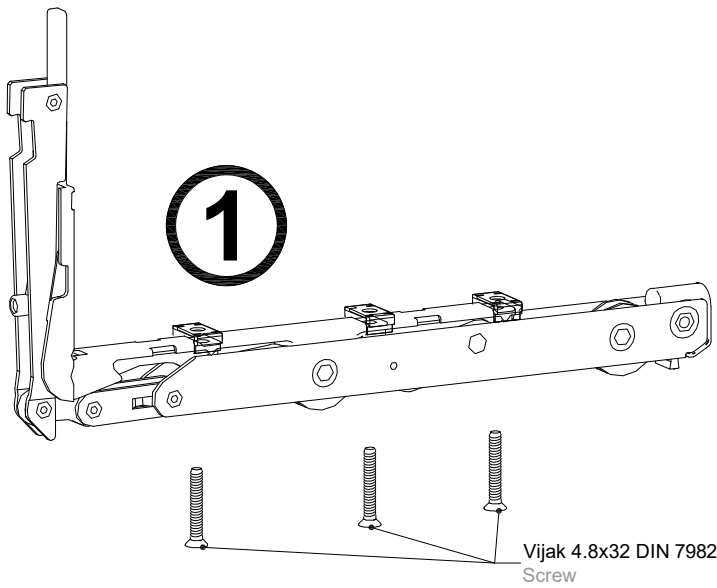
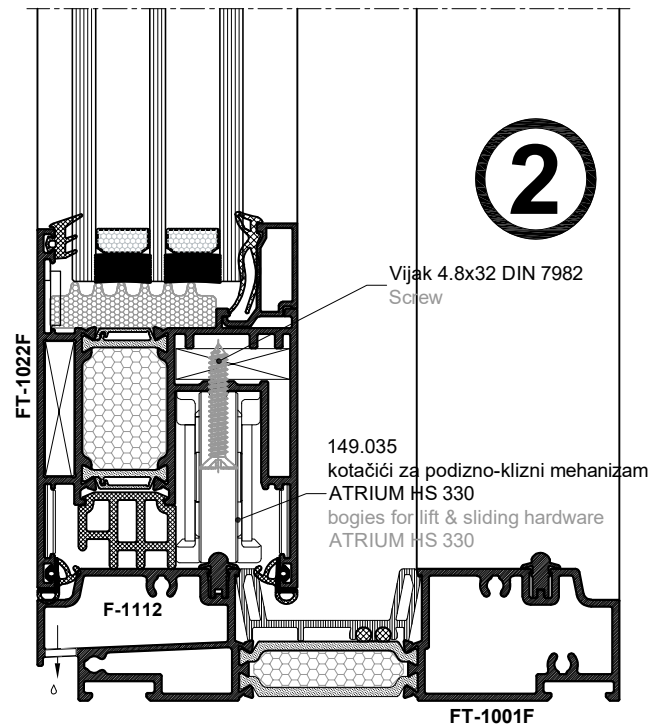
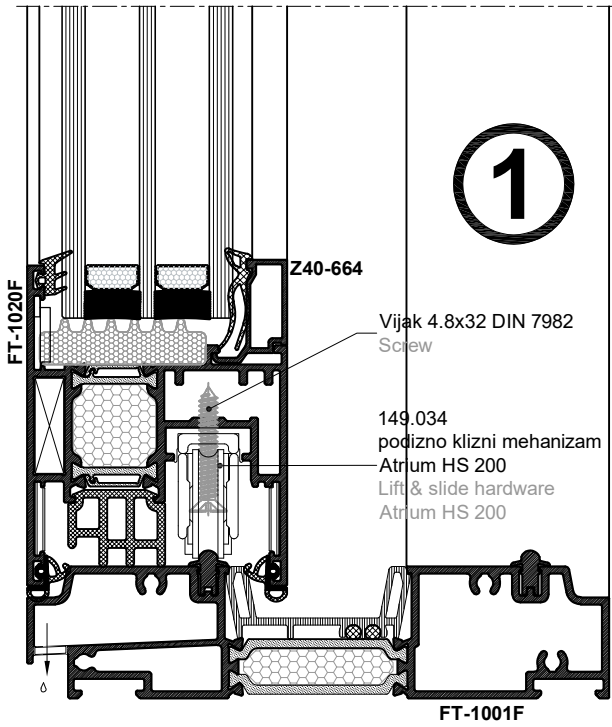

# Obrada i montaža (Termo 150 plus)

## Processing and montage (Termo 150 plus)



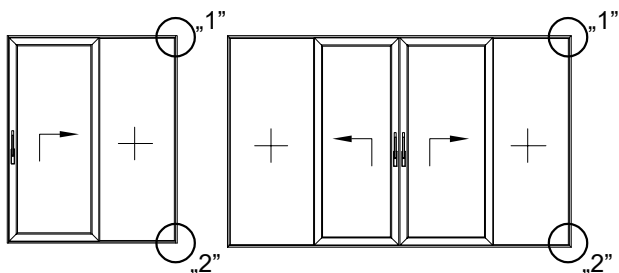

### OBRADA I SPAJANJE OKVIRA VRATA PROCESSING AND MOUNTING DOOR FRAME

433.036  
vijci 4.2x45 DIN 7981  
screws 4.2x45 DIN 7981

-obrada rupa na profilu FT-1103F  
-processing holes on profile FT-1103F

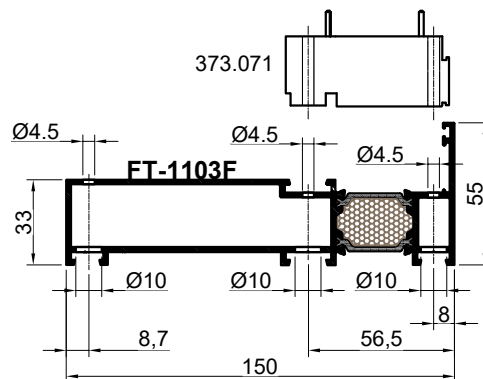
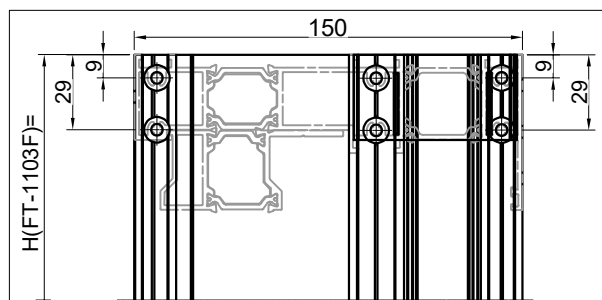
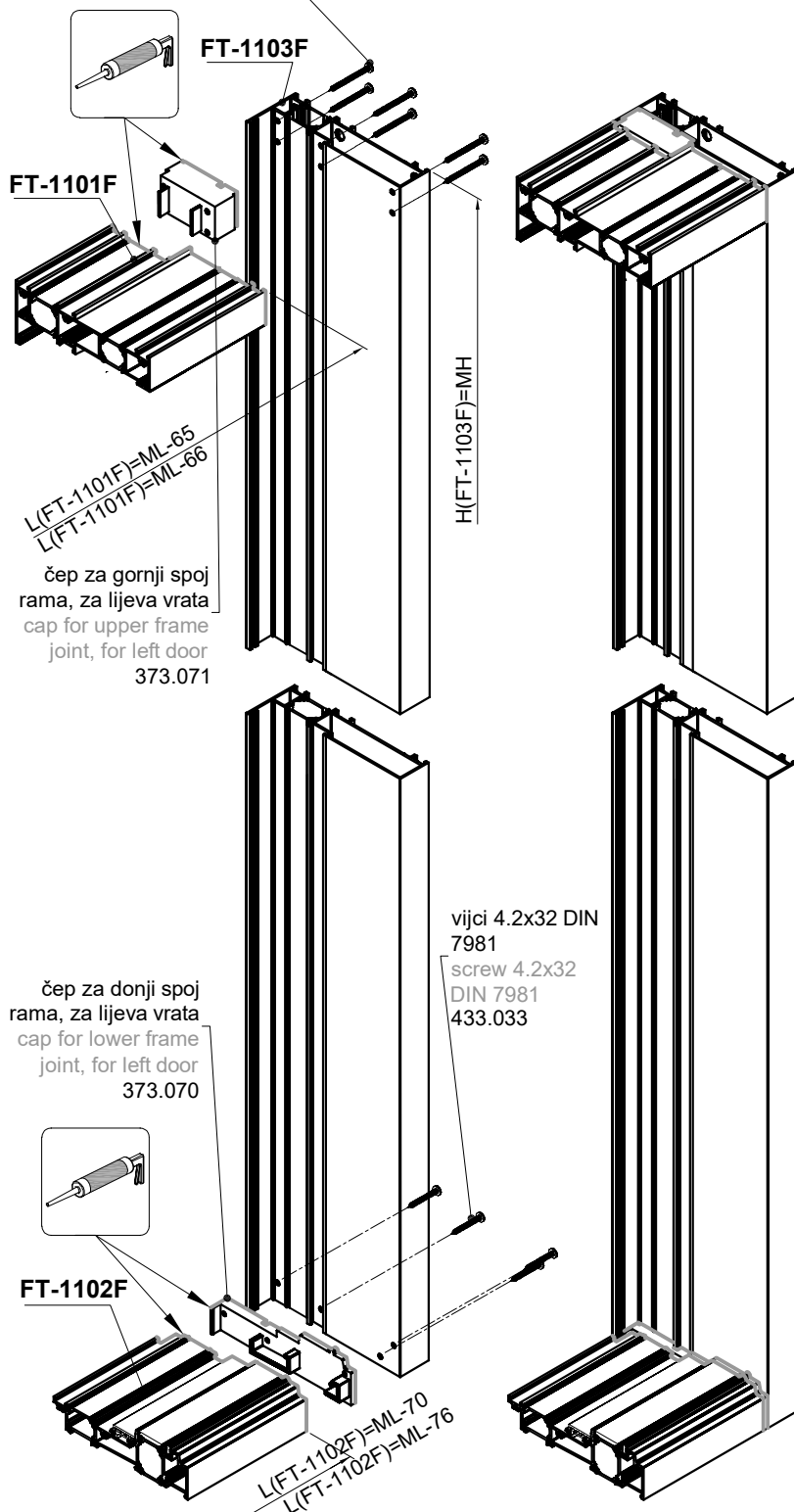

### Obrada profila FT-1103F Processing profile FT-1103F

-profili okomice i vodoravnice okvira rama se spajaju pod 90°, vijcima 4.2x45 (DIN 7981)  
-mjera pilanja vodoravnog profila

$L(FT-1101F)=ML-65$   
 $L(FT-1102F)=ML-70$



$L(FT-1101F)=ML-66$   
 $L(FT-1102F)=ML-76$

-mjera pilanja okomitog profila  $H(FT-1103F)=MH$   
-the vert.frame profile and the horiz frame profile are connected under 90°, with screws 4.2x32 (DIN 7981) with screws 4.2x45 (DIN 7981)

-mjera pilanja okomitog profila  $H(FT-1103F)=MH$   
-cutting profile lenght  
 $L(FT-1101F)=ML-65$   
 $L(FT-1102F)=ML-70$

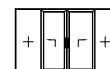

$L(FT-1101F)=ML-66$   
 $L(FT-1102F)=ML-76$

-cutting lenght of vert. frame profile  $H(FT-1103F)=MH$

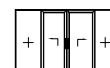

### Obrada profila FT-1103F Profile processing FT-1103F

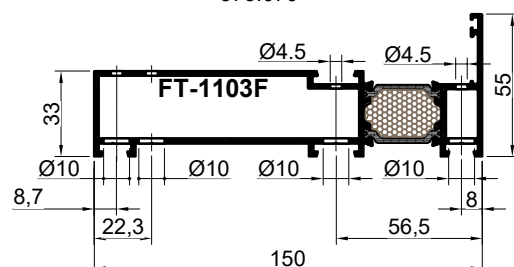
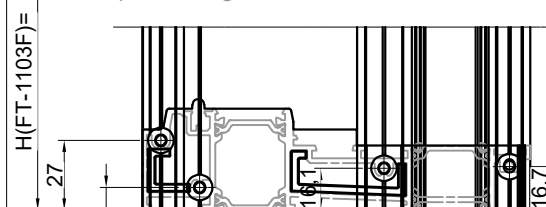

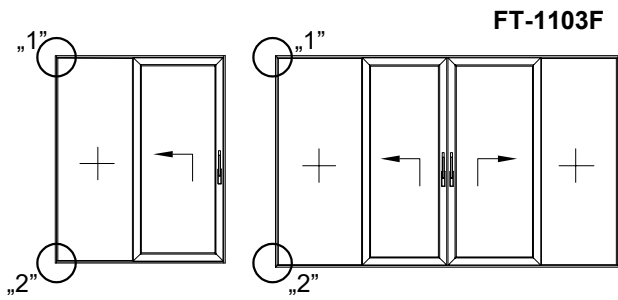

### OBRADA I SPAJANJE OKVIRA VRATA PROCESSING AND MOUNTING DOOR FRAME

-obrada rupa na profilu FT-1103F  
-processing holes on profile FT-1103F

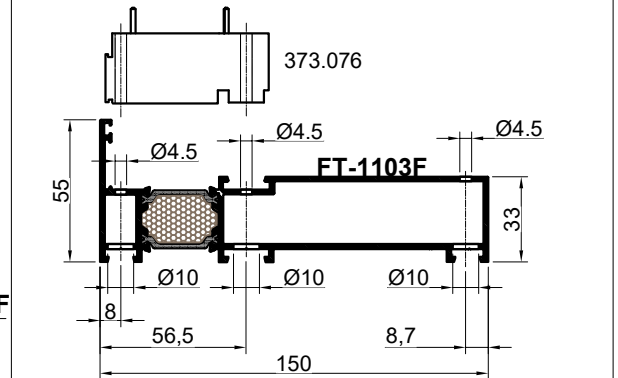
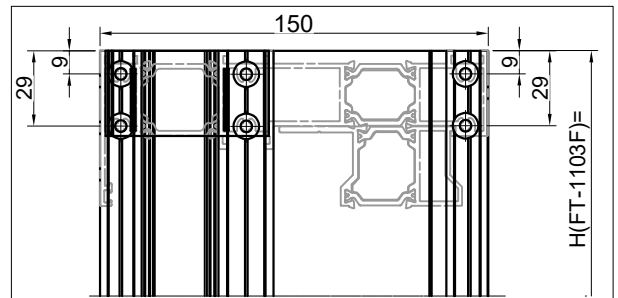

Detalj „1“  
Obrada profila FT-1103F  
Profile processing FT-1103F

-profili okomice i vodoravnice okvira rama se spajaju pod 90°, vijcima 4.2x45 (DIN 7981)  
-the vert.frame profile and the horiz frame profile are connected under 90°, with screws 4.2x45 (DIN 7981)

-mjera pilanja vodoravnog profila  
L (FT-1101F)=ML-65  
L (FT-1102F)=ML-70

L (FT-1101F)=ML-66  
L (FT-1102F)=ML-76

-mjera pilanja okomitog profila H (FT-1103F)=MH  
-the vert.frame profile and the horiz frame profile are connected under 90°, with screws 4.2x32 (DIN 7981) with screws 4.2x45 (DIN 7981)

-cutting profile lenght  
L (FT-1101F)=ML-65  
L (FT-1102F)=ML-70

L (FT-1101F)=ML-66  
L (FT-1102F)=ML-76

-cutting lenght of vert. frame profile H(FT-1103F)=MH

Detalj „2“  
Obrada profila FT-1103F  
Profile processing FT-1103F

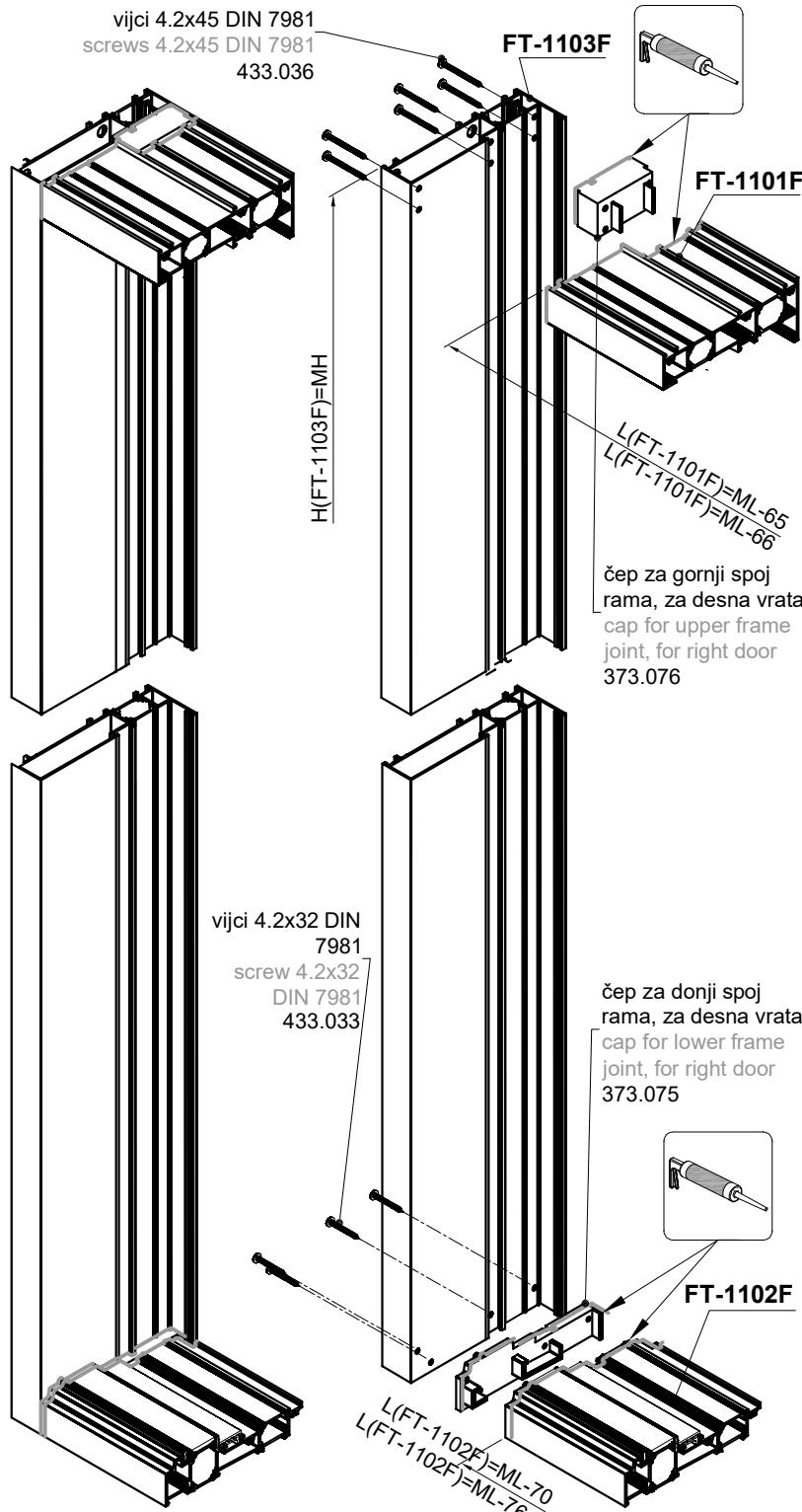
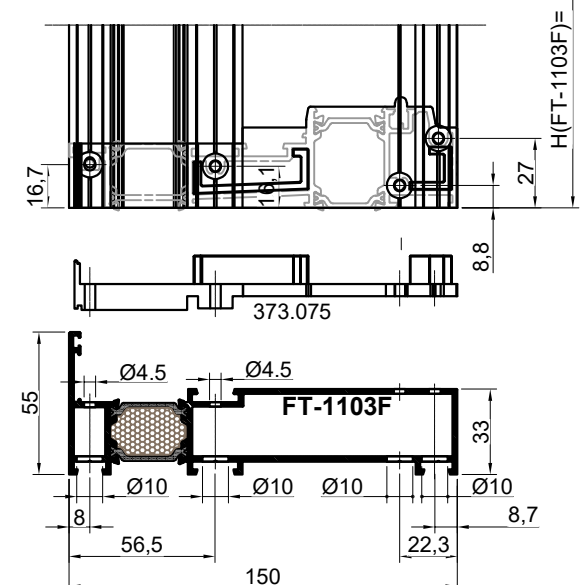

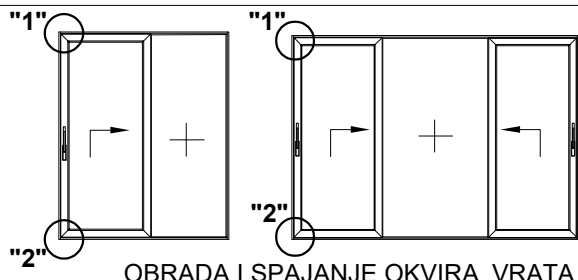

### OBRADA I SPAJANJE OKVIRA VRATA

-obrada rupa na profilu FT-1100F se radi šablonima tipa Feal

### PROCESSING AND MOUNTING DOOR FRAME

-processing holes on profile FT-1000F are made by Feal type templates

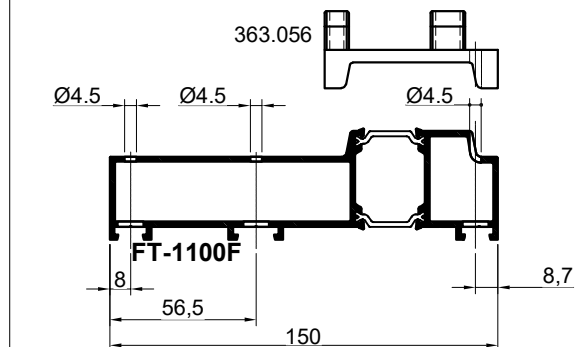
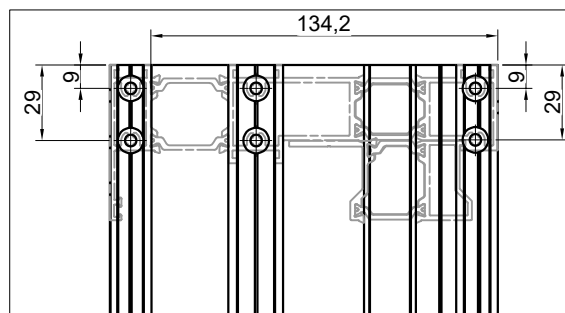
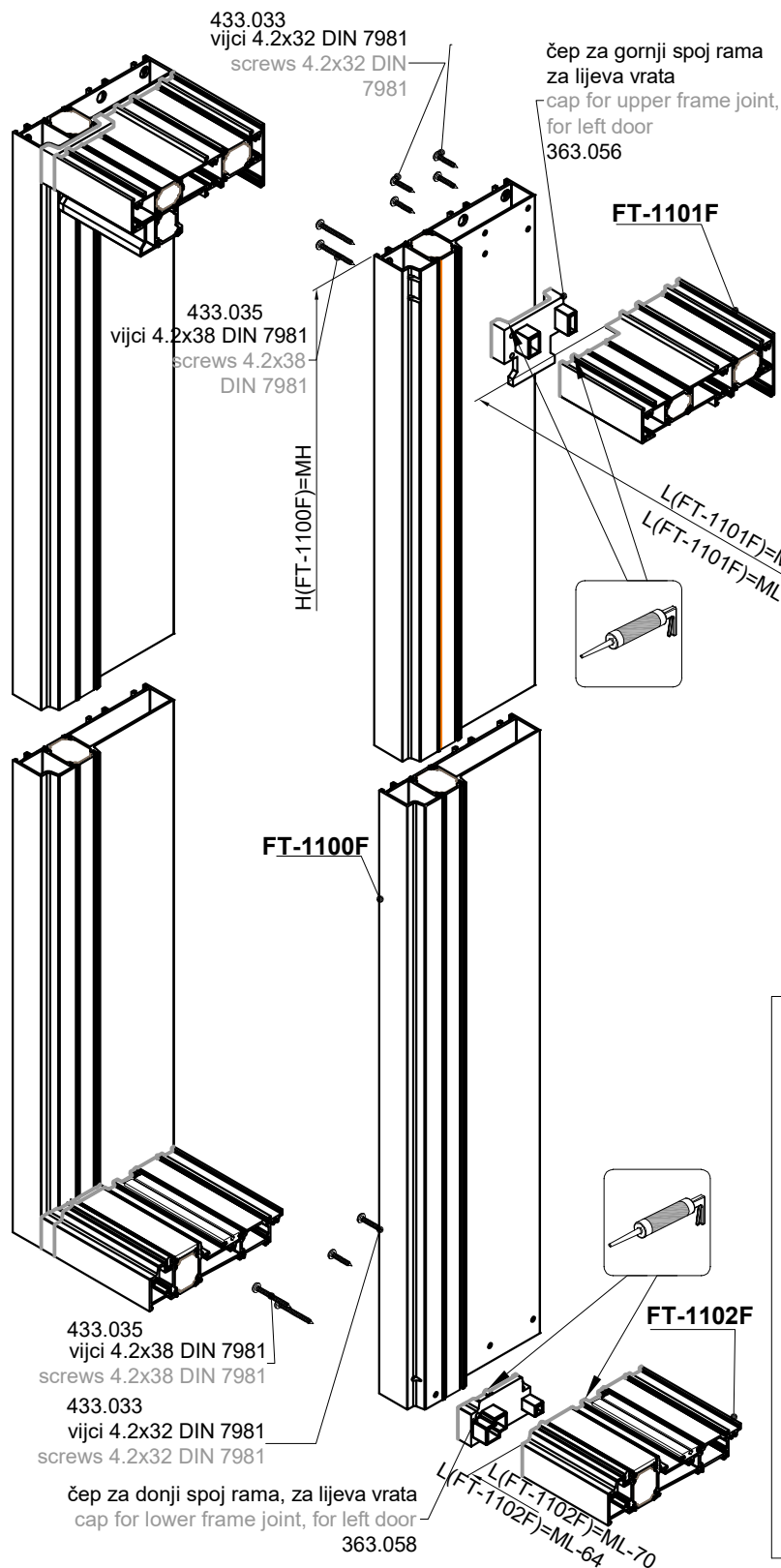

Obrada profila FT-1100F  
Processing profile FT-1100F

Detalj "1"

-profili okomice i vodoravnice okvira rama se spajaju pod 90°, vijcima 4.2x32 (DIN 7981)

-mjera pilanja vodoravnog profila

L (FT-1101F)=ML-65  
L (FT-1102F)=ML-70

L (FT-1101F)=ML-64  
L (FT-1102F)=ML-64

-mjera pilanja okomiog profila H (FT-1100F)=MH  
-the vert. frame profile and the horizontal frame profile are connected under 90°, with screws 4.2x32 (DIN 7981)

-cutting profile length

L (FT-1101F)=ML-65  
L (FT-1102F)=ML-70

L (FT-1101F)=ML-64  
L (FT-1102F)=ML-64

-cutting length of vert frame profile H (FT-1100F)=MH

Detalj "2"

Obrada profila FT-1100F  
Processing profile FT-1100F

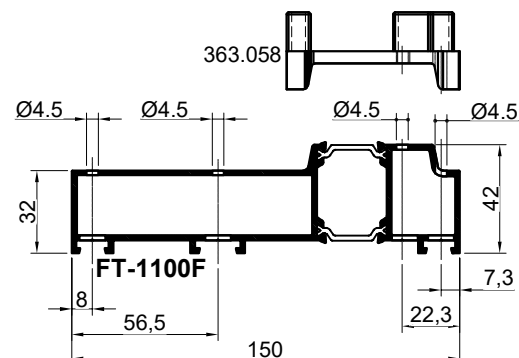
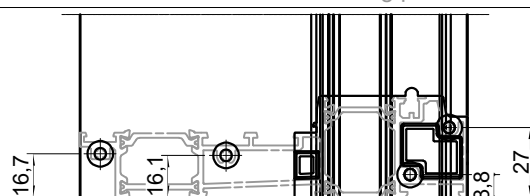

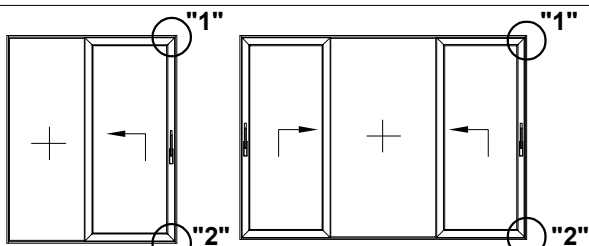

### OBRADA I SPAJANJE OKVIRA VRATA

-obrada rupa na profilu FT-1100F se radi šablonima tipa Feal

### PROCESSING AND MOUNTING DOOR FRAME

-processing holes on profile FT-1000F are made by Feal type templates

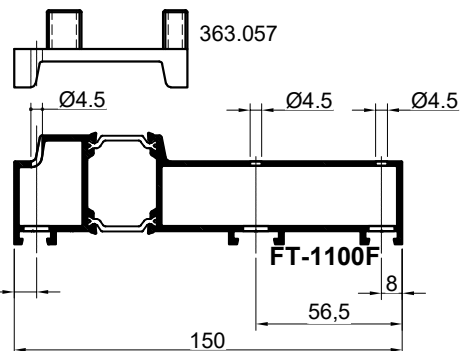
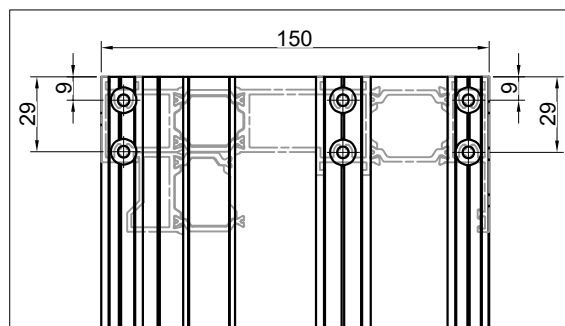
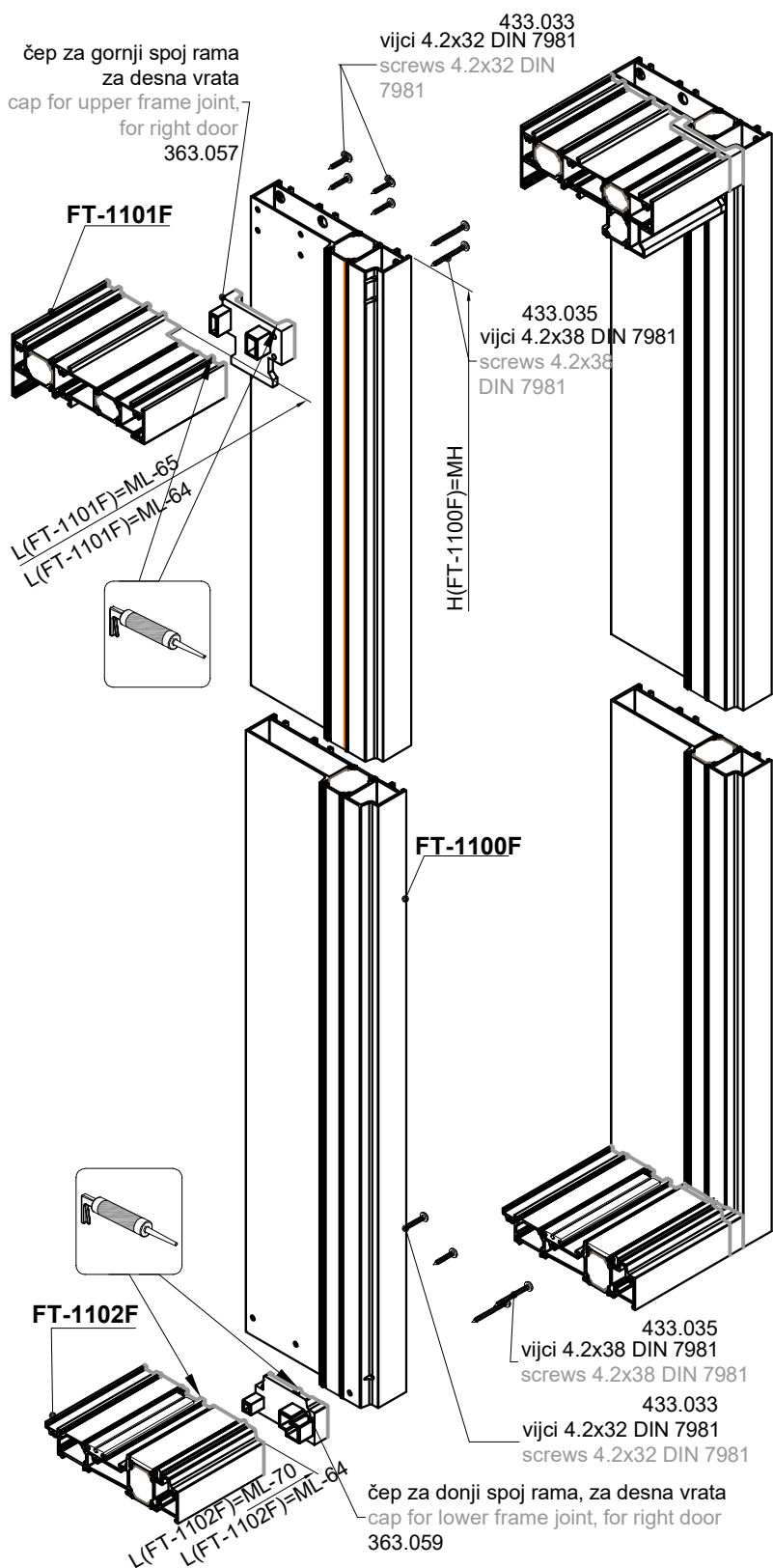

Detalj "1"

Obrada profila FT-1100F  
Processing profile FT-1100F

-profili okomice i vodoravnice okvira rama se spajaju pod 90°, vijcima 4.2x32 (DIN 7981)

-mjera pilanja vodoravnog profila

L (FT-1101F)=ML-65

L (FT-1102F)=ML-70

L (FT-1101F)=ML-64

L (FT-1102F)=ML-64

-mjera pilanja okomiog profila H (FT-1100F)=MH  
-the vert. frame profile and the horizontal frame profile are connected under 90°, with screws 4.2x32 (DIN 7981)

-cutting profile length

L (FT-1101F)=ML-65

L (FT-1102F)=ML-70

L (FT-1101F)=ML-64

L (FT-1102F)=ML-64

-cutting length of vert frame profile H (FT-1100F)=MH

Detalj "2"

Obrada profila FT-1100F  
Processing profile FT-1100F

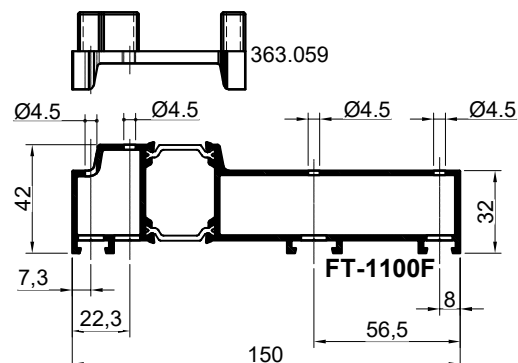
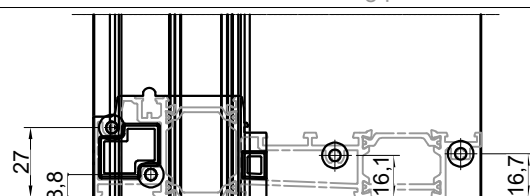

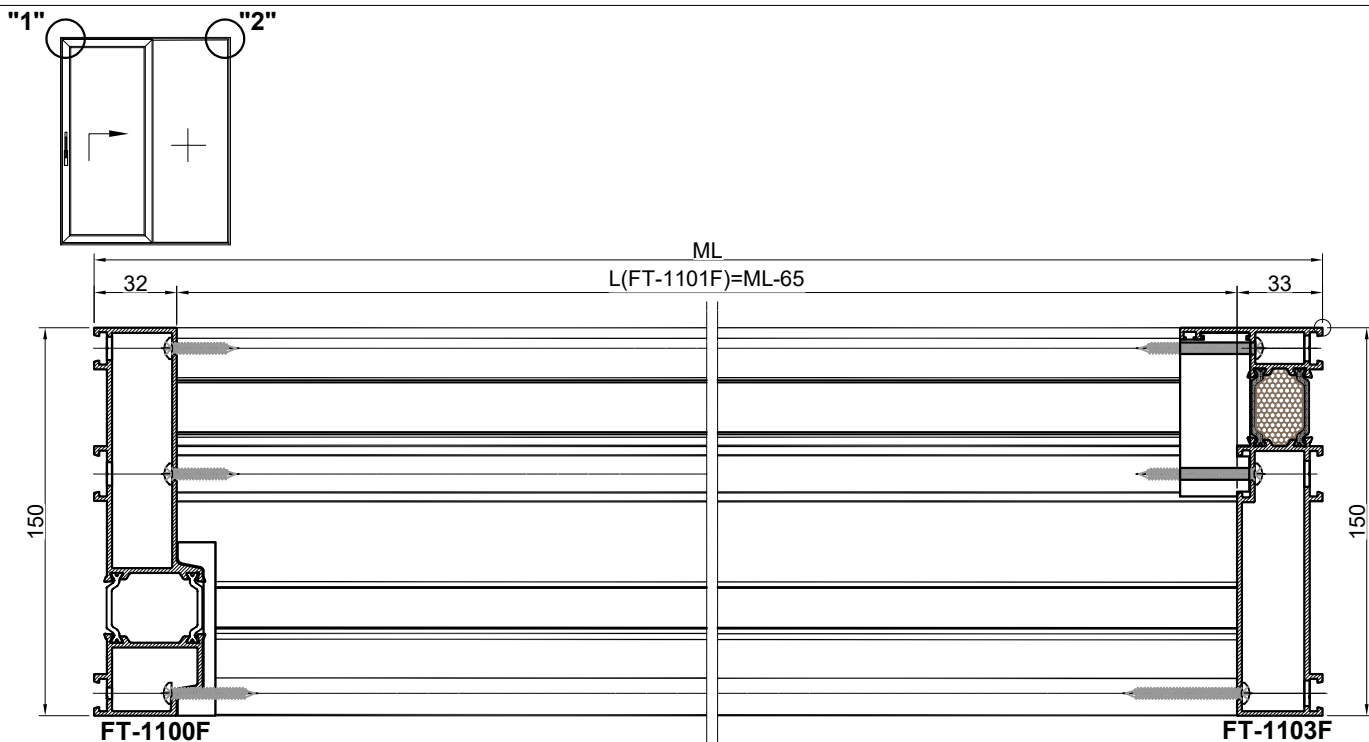

Obrada profila FT-1101F  
prema vertikalnom profilu rama FT-1100F  
Processing profile FT-1101F towards vert.  
frame profile FT-1100F

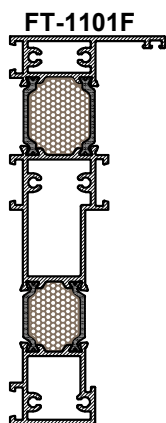
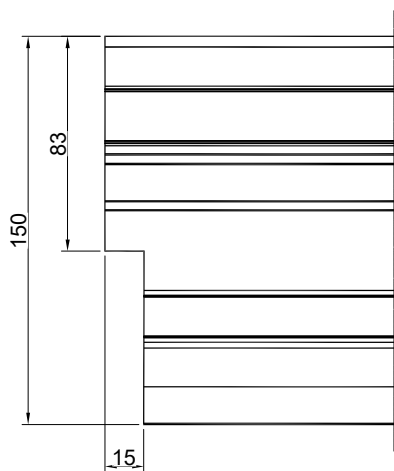

433.033  
(vijci 4.2x32 DIN 7981)  
(screws 4.2x32 DIN 7981)

433.035  
(vijci 4.2x38 DIN 7981)  
(screws 4.2x38 DIN 7981)

FT-1100F

Detalj "1"

čep za gornji spoj rama  
za lijeva vrata  
363.056  
cap for upper frame joint,  
for left door  
363.056

FT-1101F

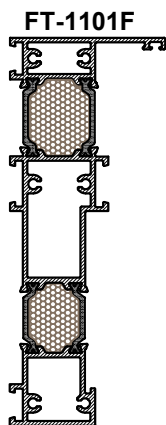
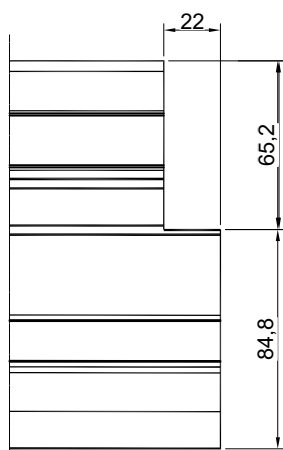
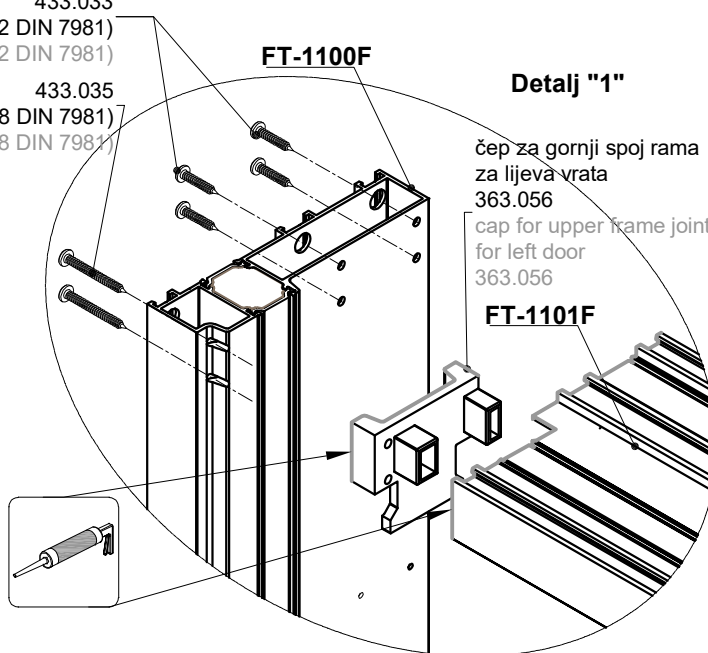

FT-1101F

433.036  
vijci 4.2x45 DIN 7981  
screws 4.2x45 DIN 7981

FT-1103F

čep za gornji spoj rama  
za lijeva vrata  
373.071  
cap for upper frame joint,  
for left door  
373.071

Detalj "2"

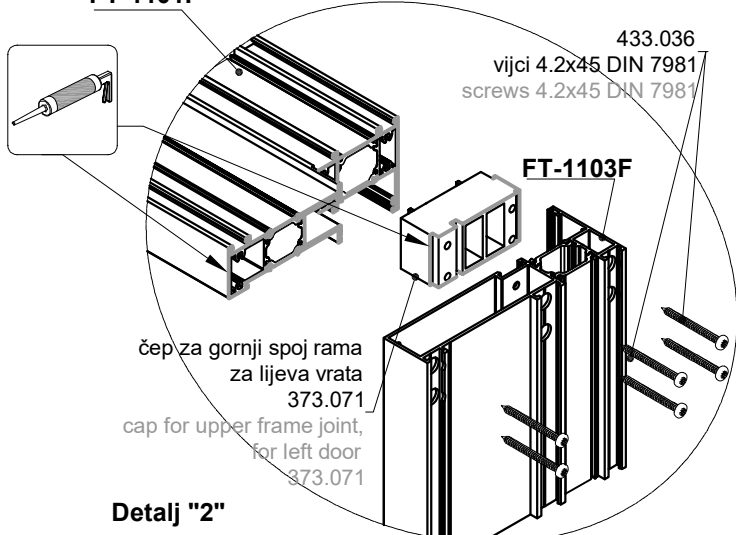

Obrada profila FT-1101F  
prema vertikalnom profilu rama FT-1103F  
Processing profile FT-1101F  
towards vert. frame profile FT-1103F

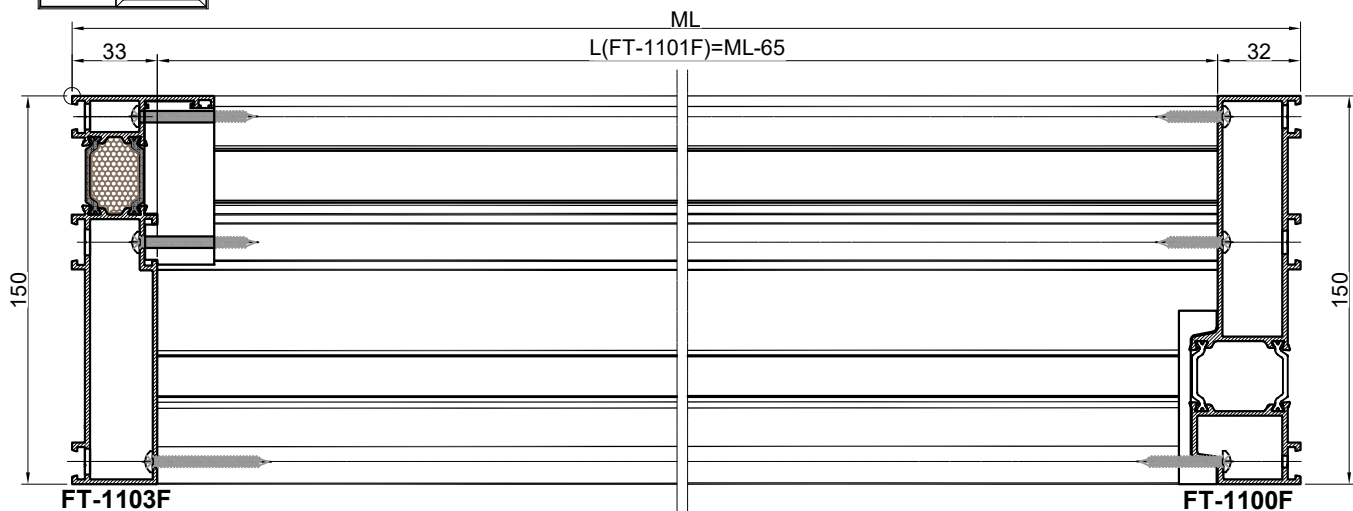
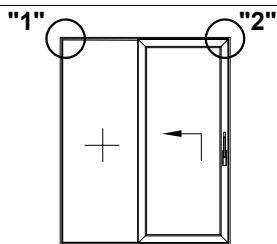

Obrada profila FT-1101F  
prema vertikalnom profilu rama FT-1100F  
Processing profile FT-1101F towards vert.  
frame profile FT-1100F

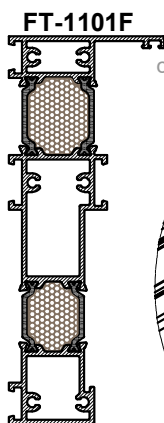
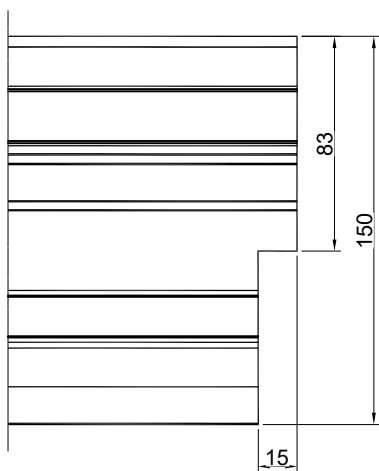

### Detalj "2"

čep za gornji spoj rama  
za desna vrata  
363.057  
cap for upper frame joint,  
for right door  
363.057

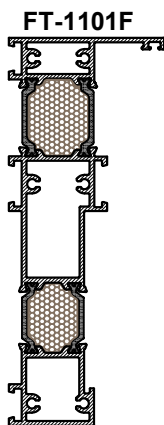
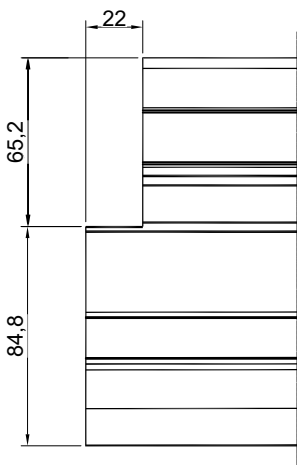
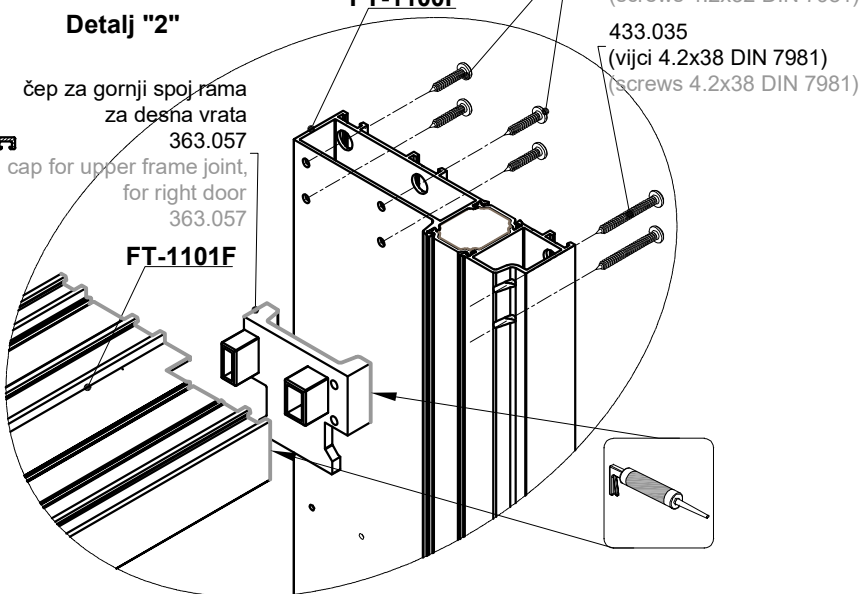

433.036  
vijci 4.2x45 DIN 7981  
screws 4.2x45 DIN 7981

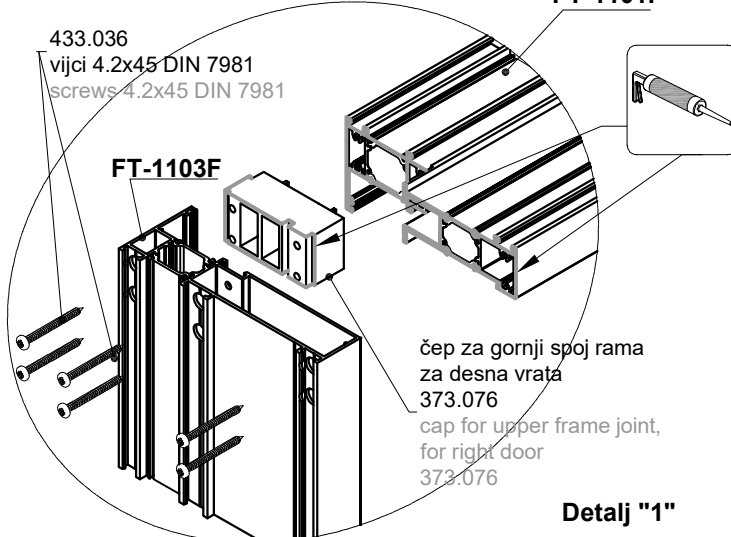

čep za gornji spoj rama  
za desna vrata  
373.076  
cap for upper frame joint,  
for right door  
373.076

### Detalj "1"

Obrada profila FT-1101F  
prema vertikalnom profilu rama FT-1103F  
Processing profile FT-1101F  
towards vert. frame profile FT-1103F

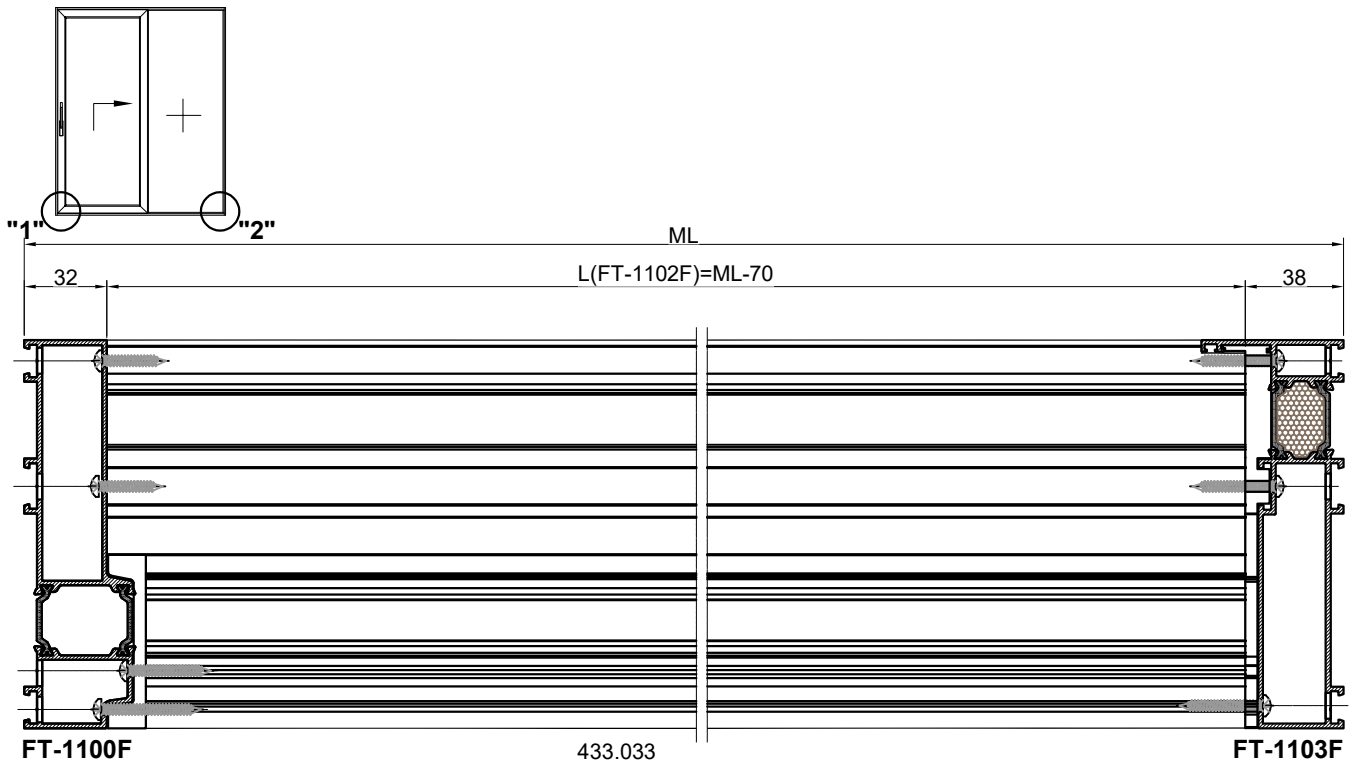

Obrada profila FT-1102F  
prema vertikalnom profilu rama FT-1100F  
Processing profile FT-1102F  
towards vert. frame profile FT-1100F

433.033  
(vijci 4.2x32 DIN 7981)  
(screws 4.2x32 DIN 7981)  
433.035  
(vijci 4.2x38 DIN 7981)  
(screws 4.2x38 DIN 7981)

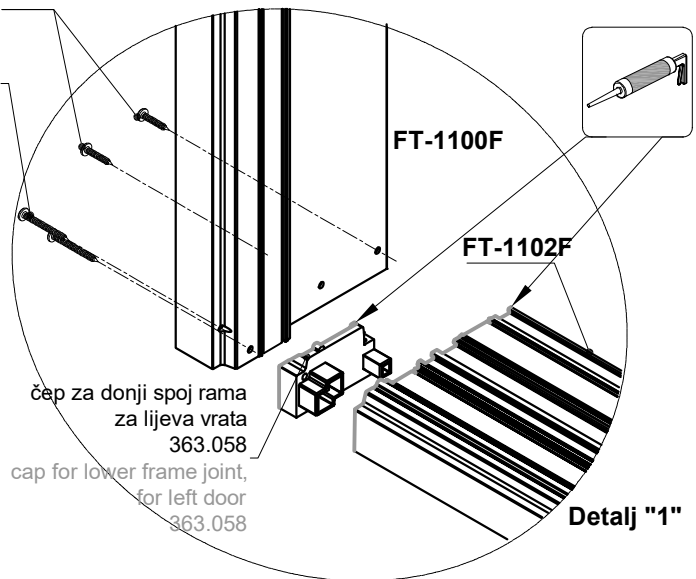
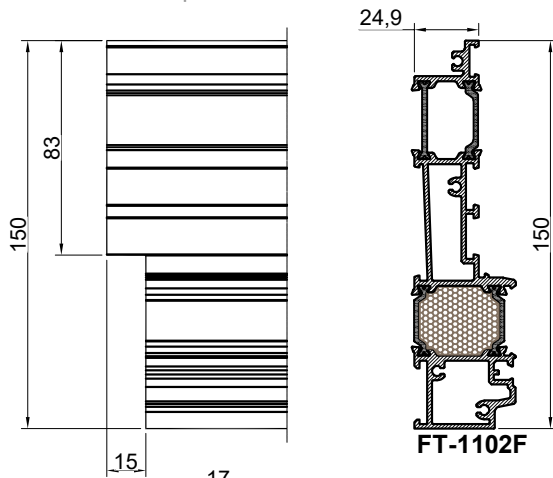

Obrada profila FT-1102F  
prema vertikalnom profilu rama FT-1103F  
Processing profile FT-1102F  
towards vert. frame profile FT-1103F

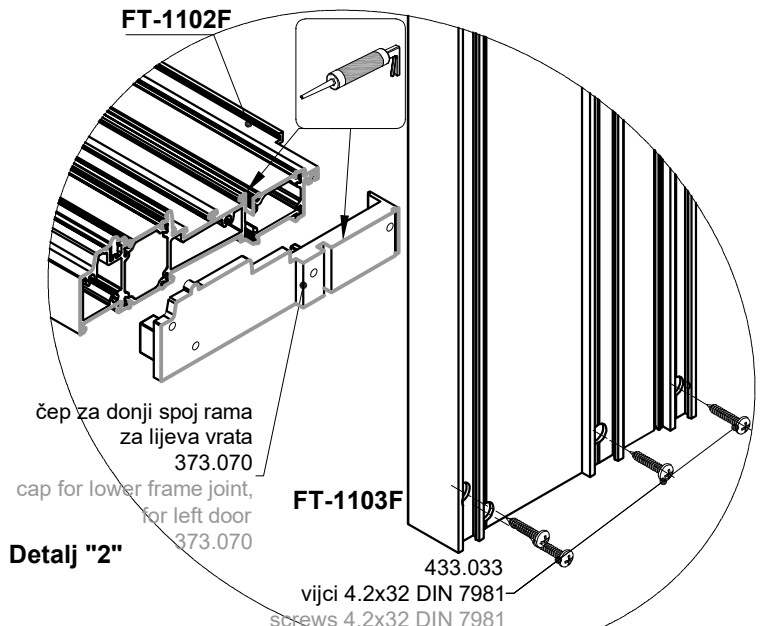
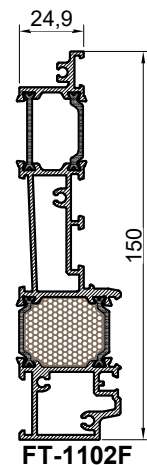

433.033  
vijci 4.2x32 DIN 7981  
screws 4.2x32 DIN 7981

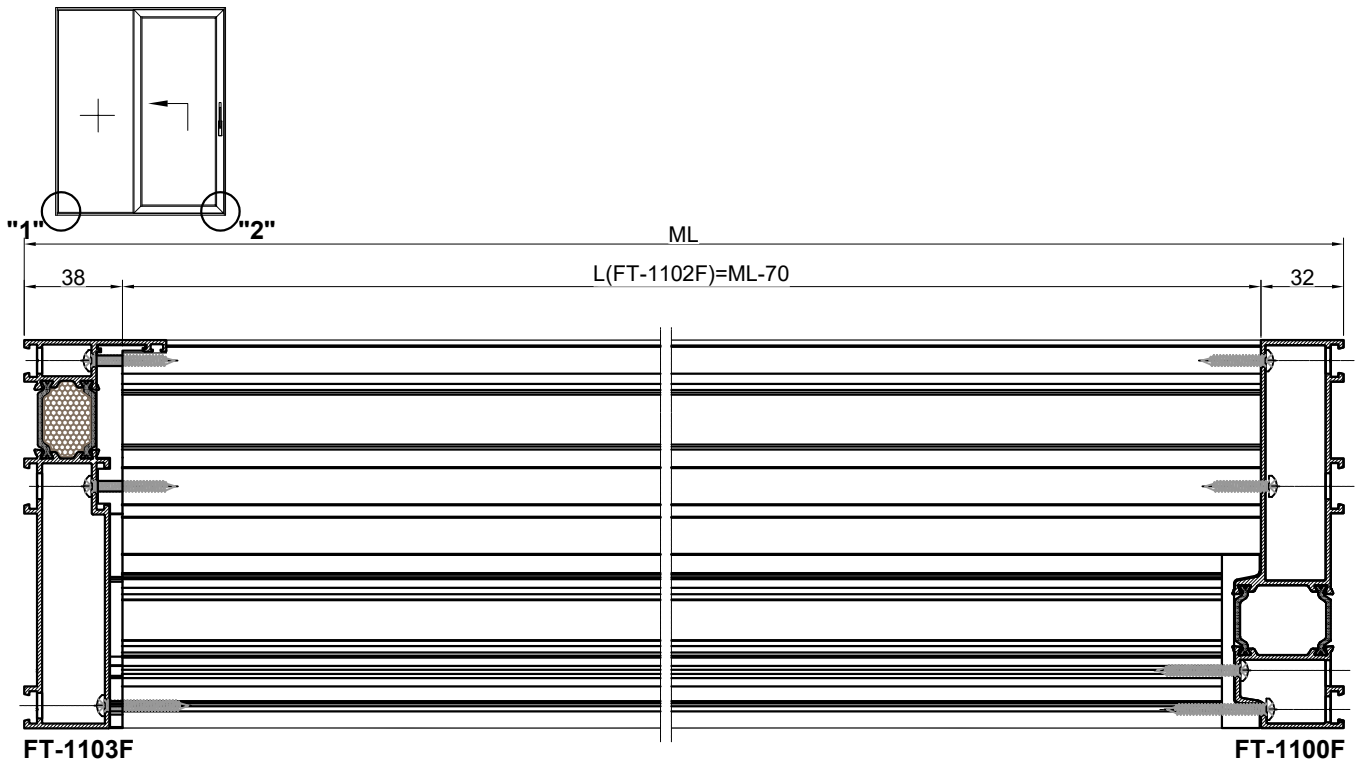

Obrada profila FT-1102F  
prema vertikalnom profilu rama FT-1100F  
Processing profile FT-1102F  
towards vert. frame profile FT-1100F

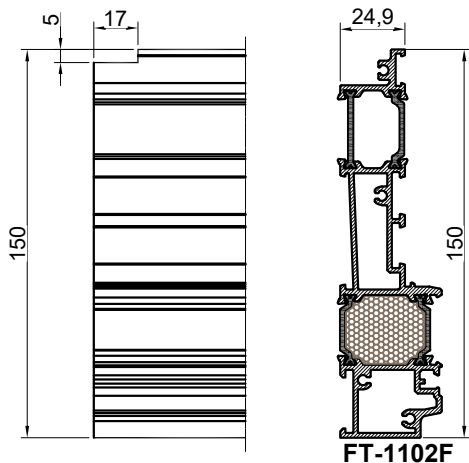
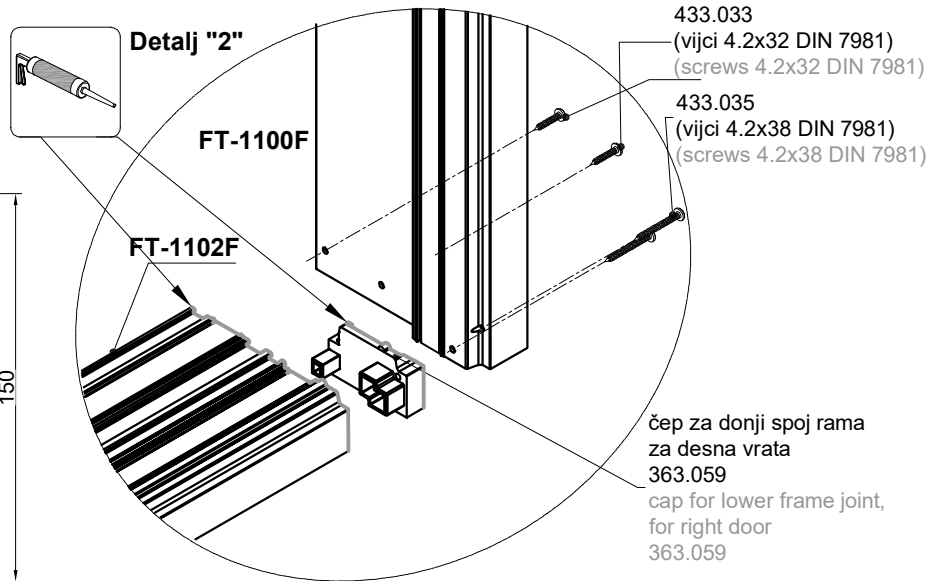
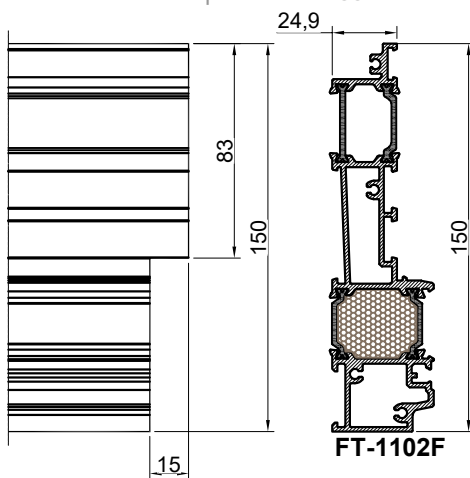

Obrada profila FT-1102F  
prema vertikalnom profilu rama FT-1103F  
Processing profile FT-1102F  
towards vert. frame profile FT-1103F

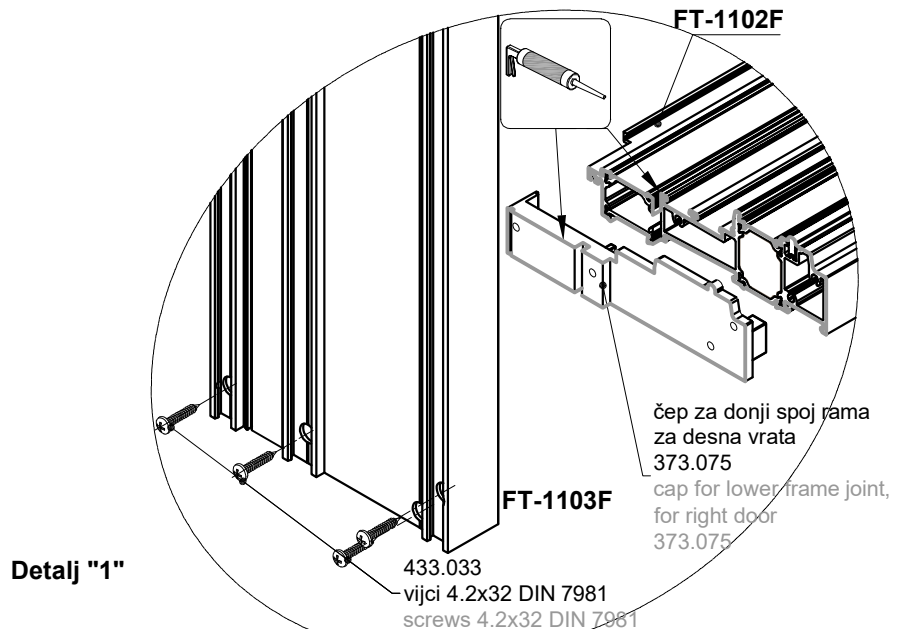

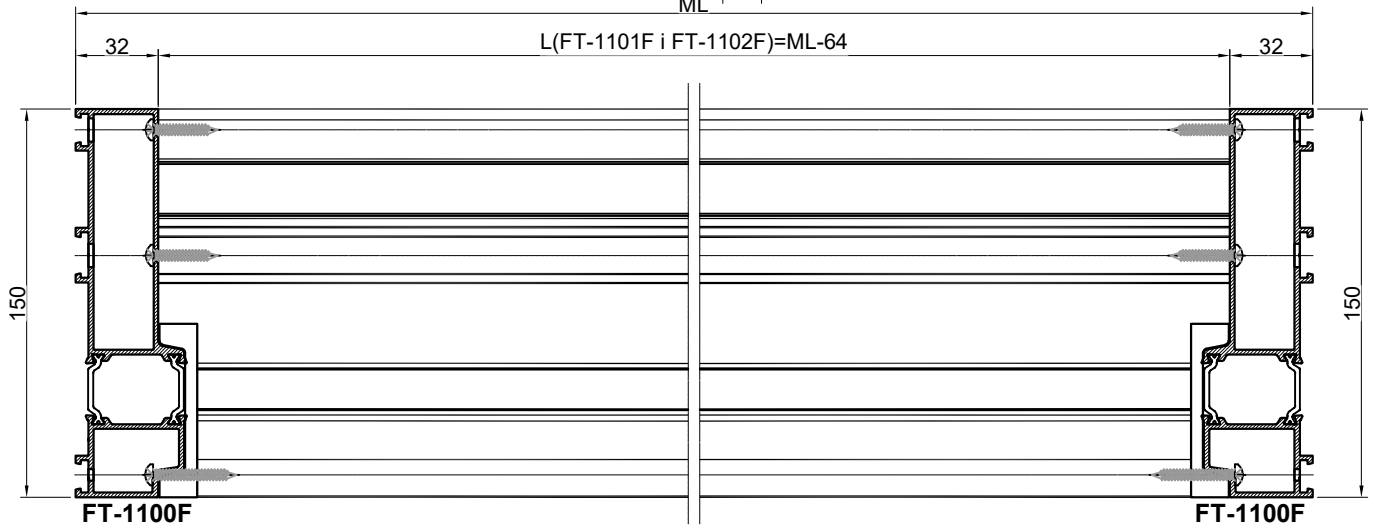
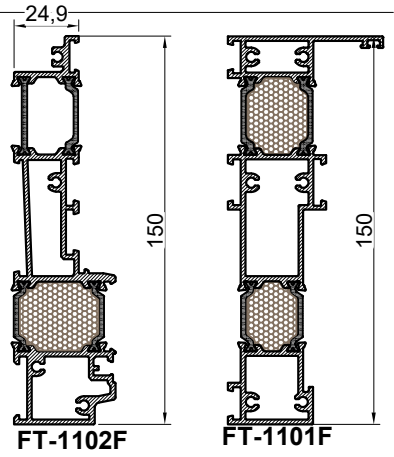
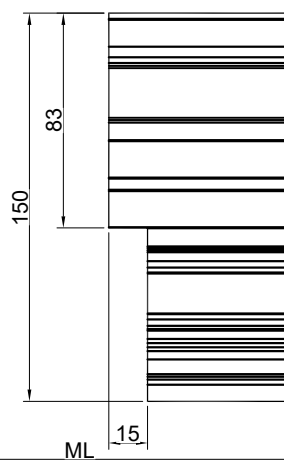
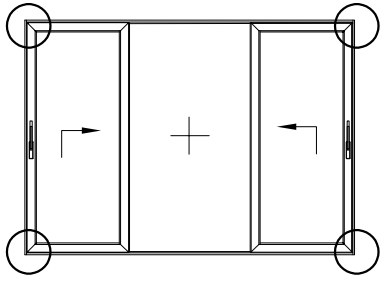

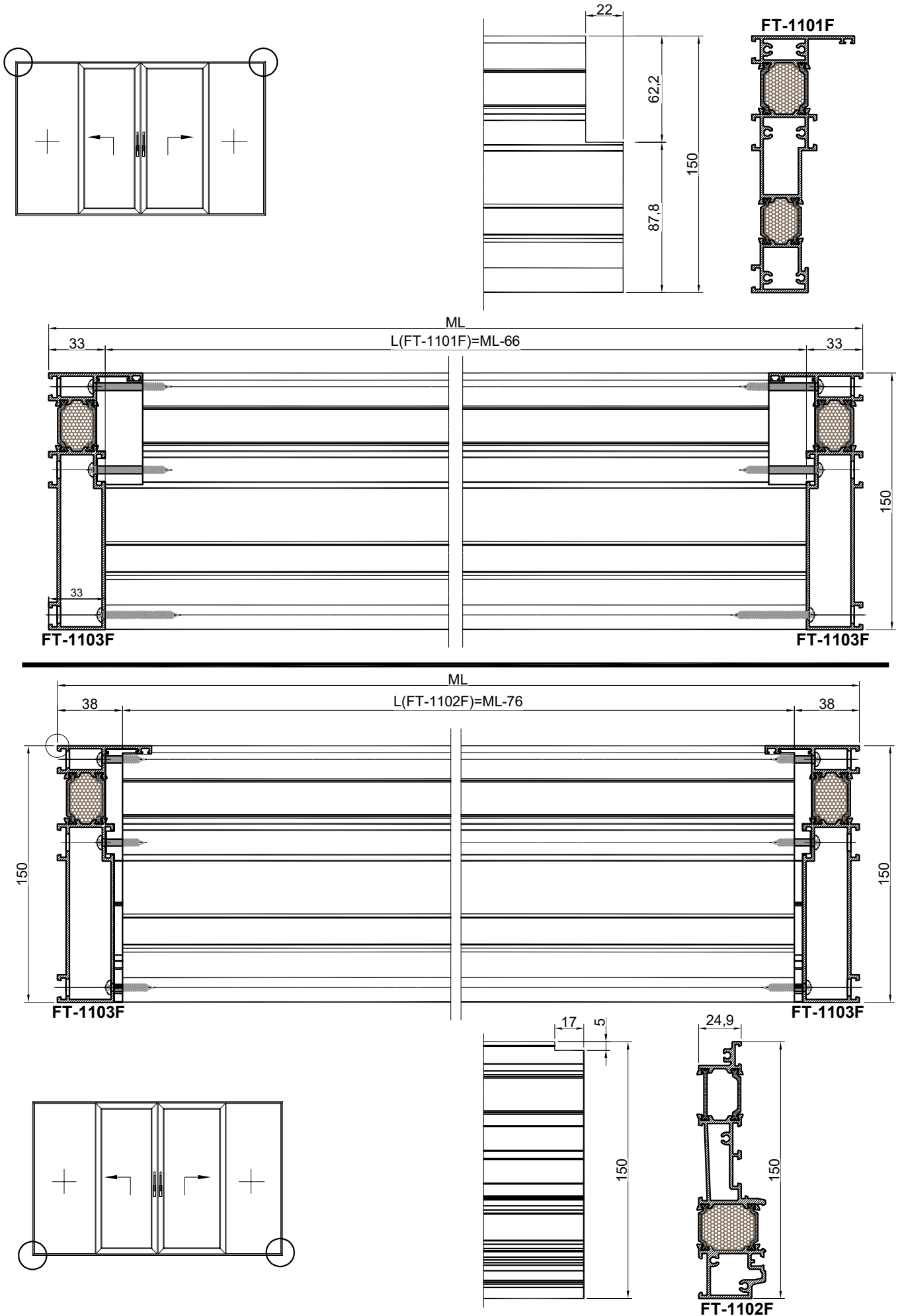

**PRESJEK C-C**  
CROSS SECTION C-C

**SPAJANJE PROFILA FT-1120F KUTNICIMA**  
CONNECTION PROFILE FT-1120F WITH CORNER BRACKETS

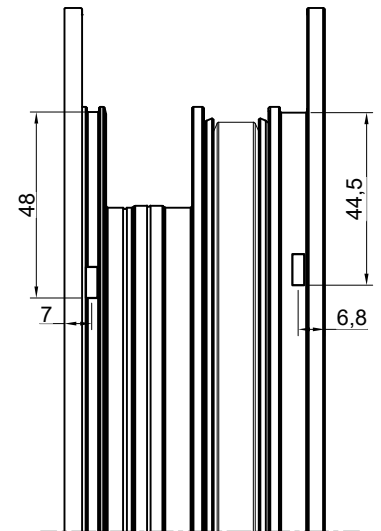
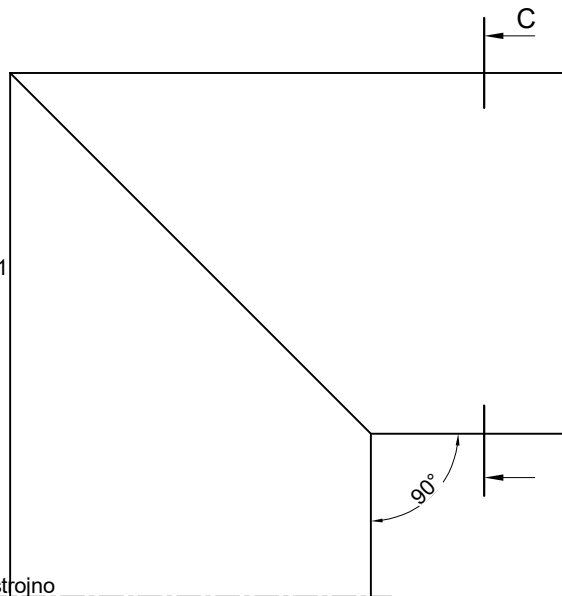
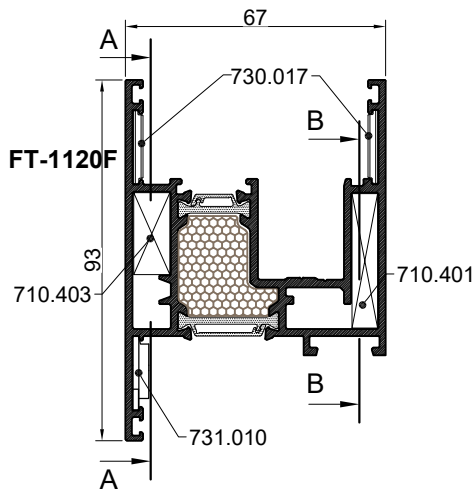

- Spajanje kutnikom **710.403** uprešavanjem stijenke profila u kutnik
- Uprešavanje izvesti kliještima art.240.001 ili strojno
- Corner bracket connection **710.403** aluminium profile corner crimping
- Corner crimping perform with pliers art.240.001 or with machine

- Spajanje kutnikom **710.401** uprešavanjem stijenke profila u kutnik
- Uprešavanje izvesti kliještima art.240.001 ili strojno
- Corner bracket connection **710.401** aluminium profile corner crimping
- Corner crimping perform with pliers art.240.001 or with machine

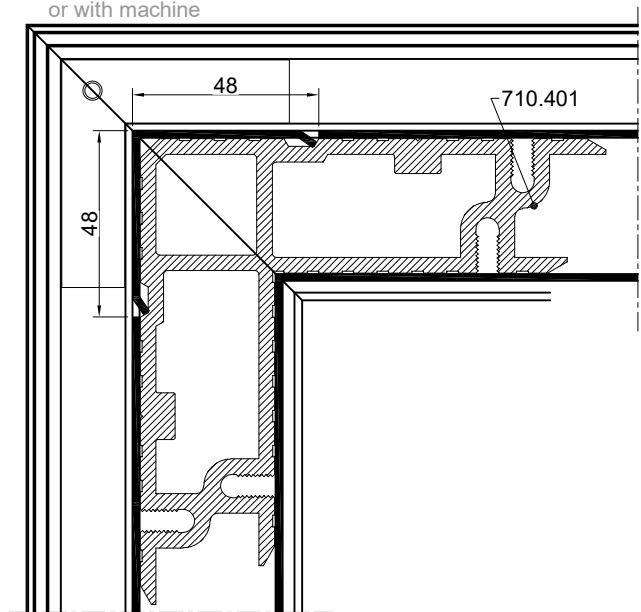
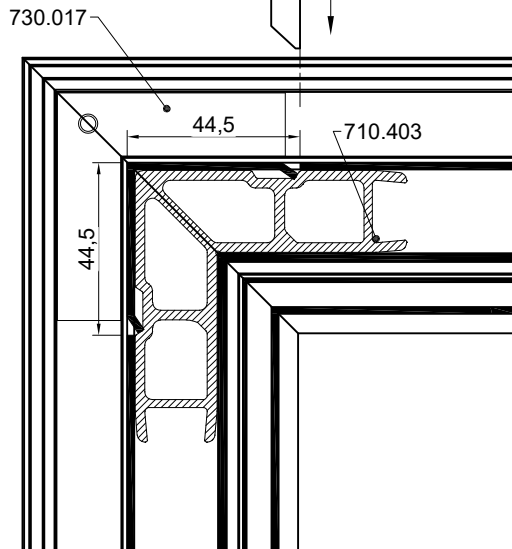

**PRESJEK A-A**  
CROSS SECTION A-A

**PRESJEK B-B**  
CROSS SECTION B-B

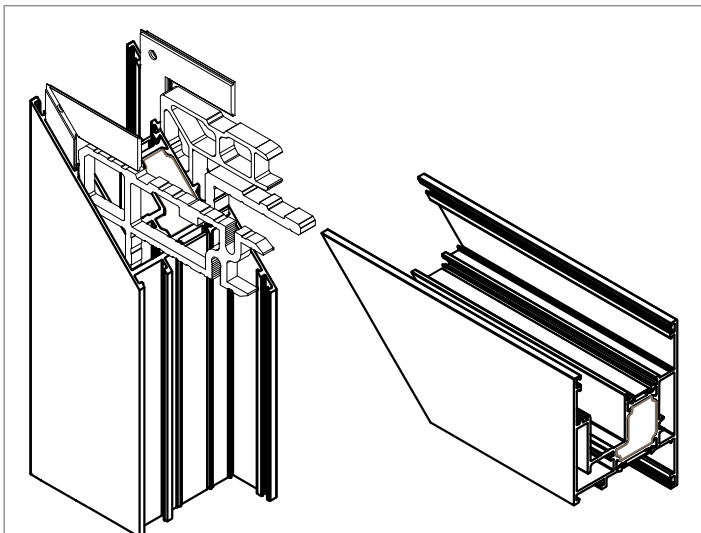

### PRESJEK C-C CROSS SECTION C-C

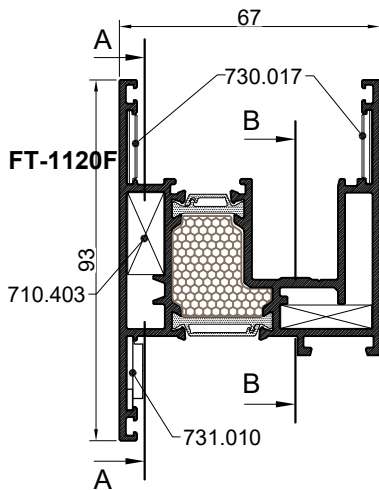

### SPAJANJE PROFILA FT-1120F KUTNICIMA CONNECTION PROFILE FT-1120F WITH CORNER BRACKETS

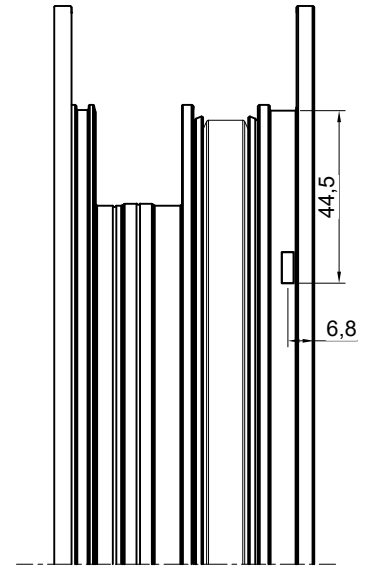
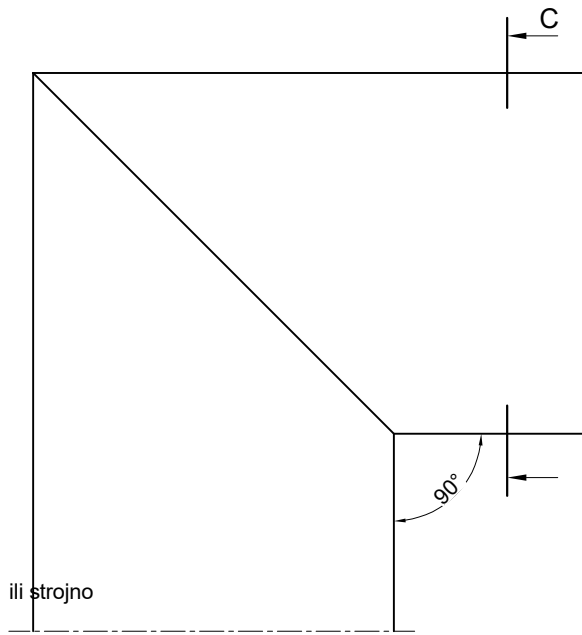

- Spajanje kutnikom **710.403** uprešavanjem stijenke profila u kutnik
- Uprešavanje izvesti kliještima art.240.001 ili strojno
- Corner bracket connection **710.403** aluminium profile corner crimping
- Corner crimping perform with pliers art.240.001 or with machine

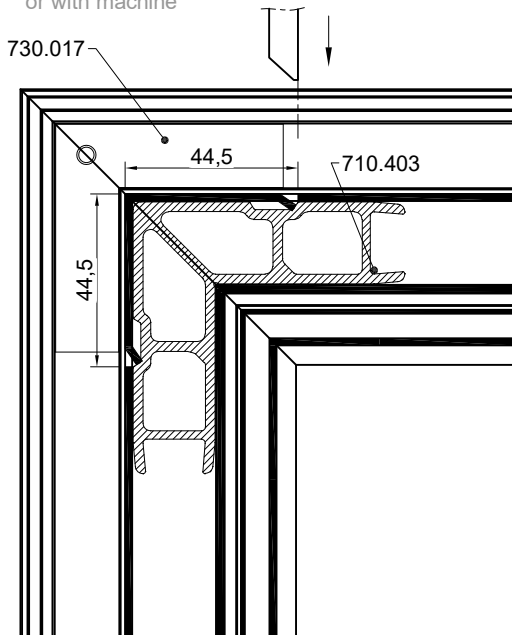

PRESJEK A-A  
CROSS SECTION A-A

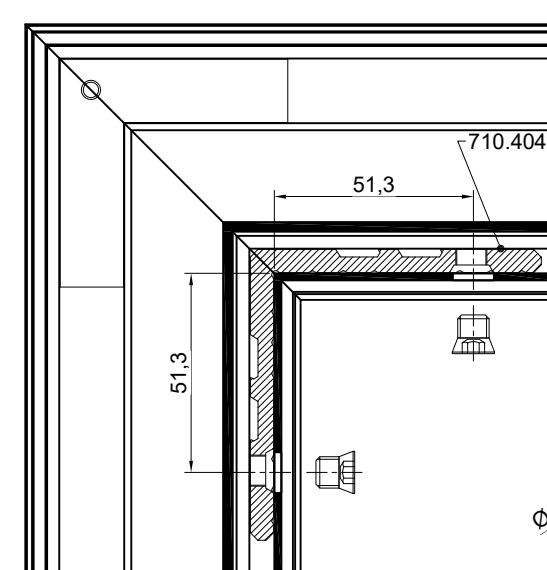

PRESJEK B-B  
CROSS SECTION B-B

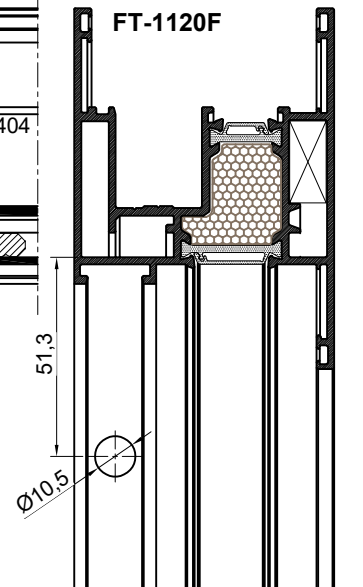

- Spajanje kutnikom **710.404** vijcima M8x10 -tip Feal (431.265)
- Obrada rupe na glodalici (bušilici) vretenastim glodalom (svrdlom) Ø10.5
- Connection with corner bracket **710.404**, screws M8x10 -type Feal (431.265)
- Processing holes on milling machine with end mill Ø10.5

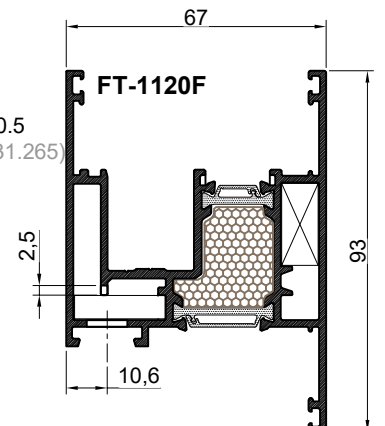

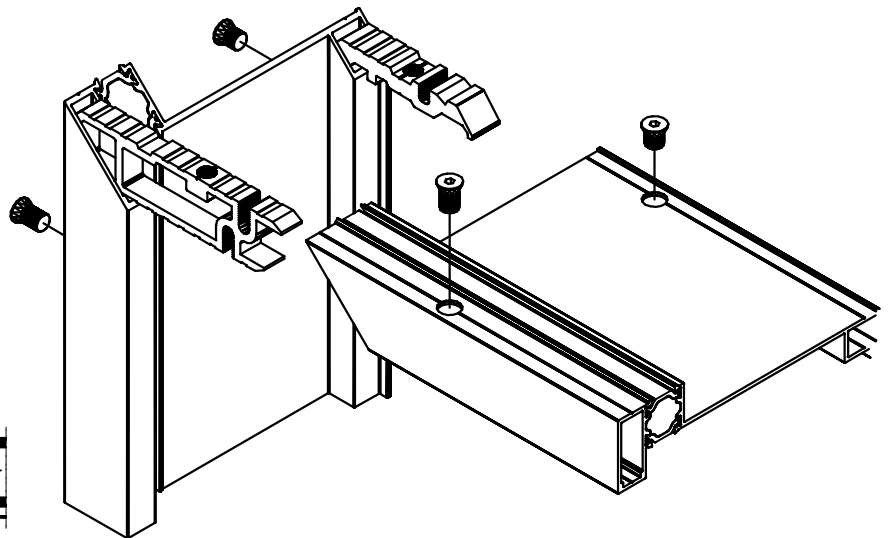
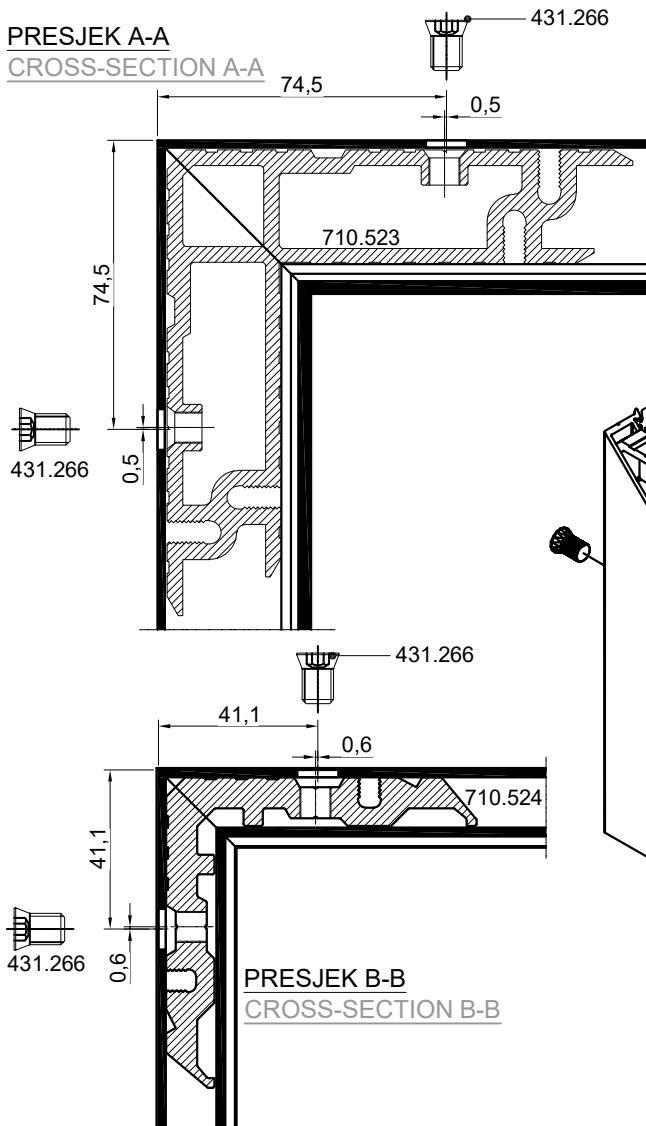
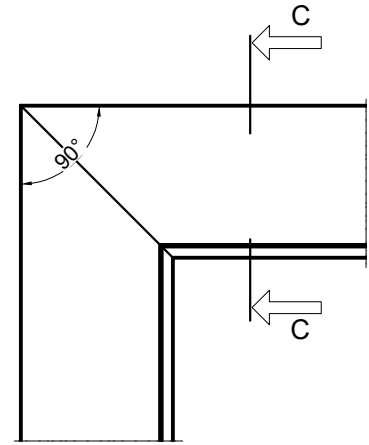
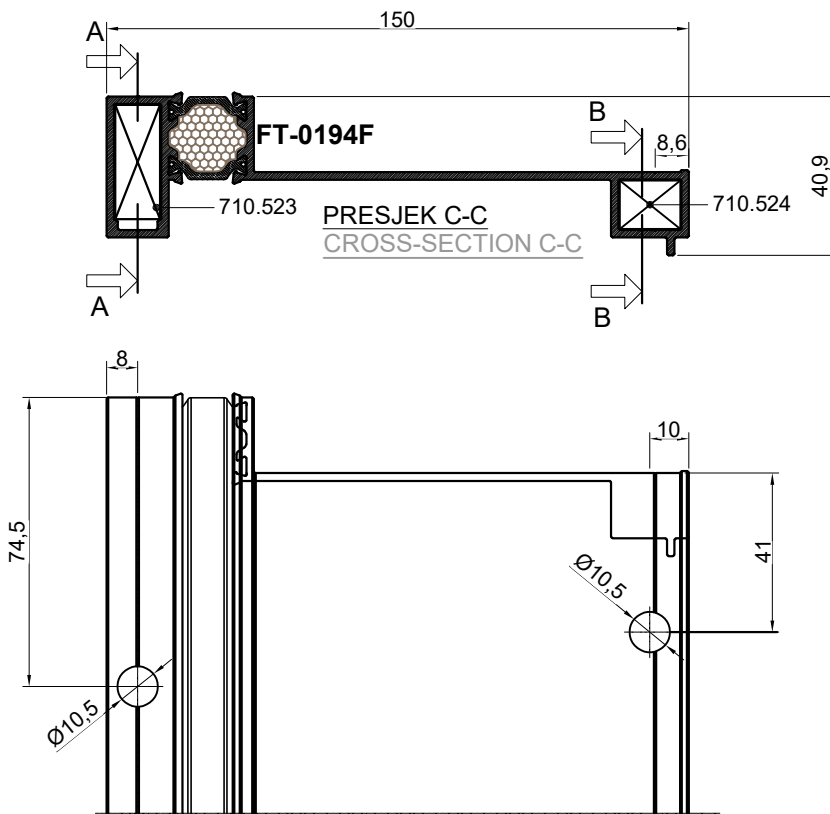

SPAJANJE PROFILA FT-0194F KUTNICIMA  
CONNECTION PROFILE FT-0194F WITH CORNER BRACKETS

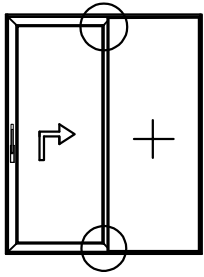

**PRESJEK C-C**  
**CROSS SECTION C-C**

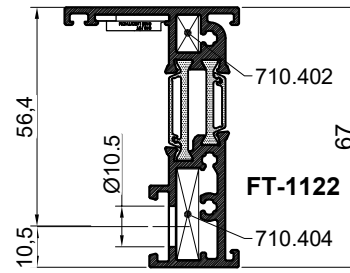
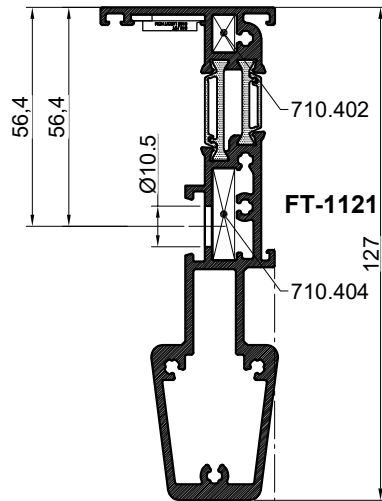

**SPAJANJE PROFILA FT-1120F SA PROFILIMA KRILA**  
**FT-1121 I FT-1122 KUTNICIMA**  
**PROFILES CONNECTION FT-1120F WITH SASH**  
**PROFILES FT-1121 AND FT-1122 WITH CORNER**  
**BRACKETS**

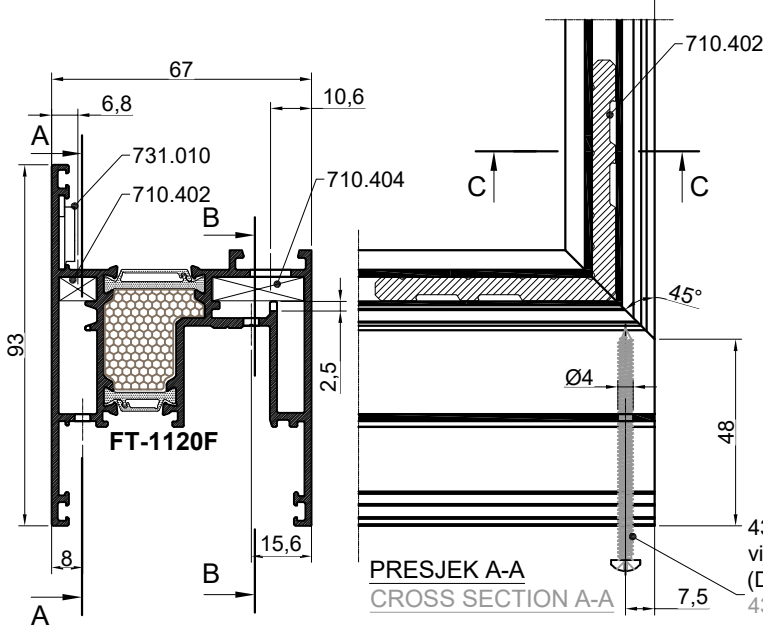

**PRESJEK A-A**  
**CROSS SECTION A-A**

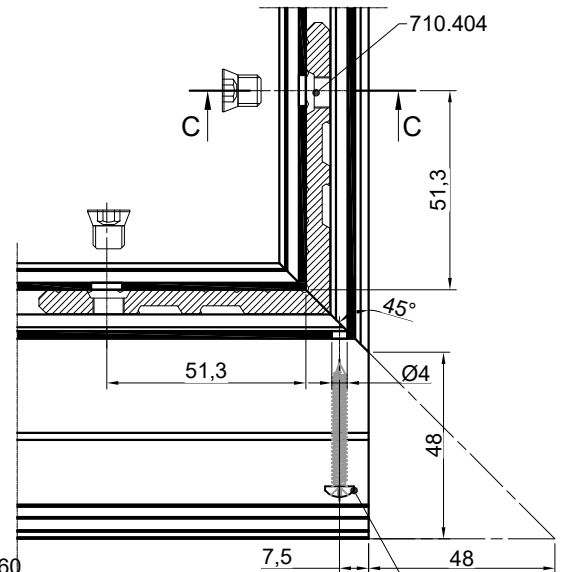

**PRESJEK B-B**  
**CROSS SECTION B-B**

433.025  
vijak 3.9x60  
(DIN 7981)  
433.025  
screw 3.9x60  
(DIN 7981)

433.021  
vijak 3.9x32  
(DIN 7981)  
433.021  
screw 3.9x32  
(DIN 7981)

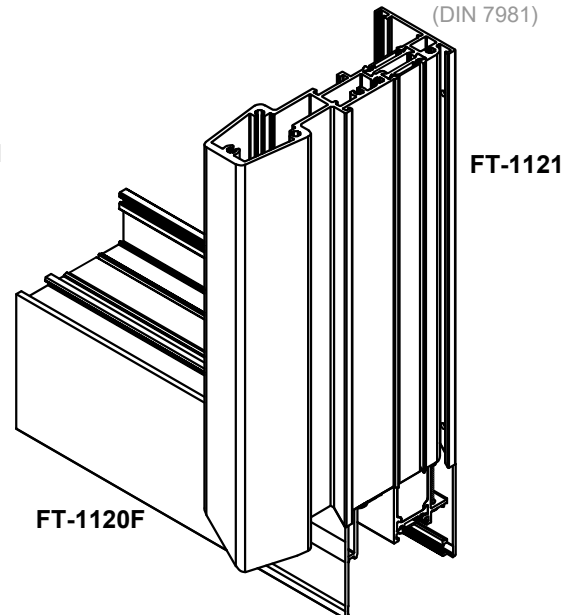
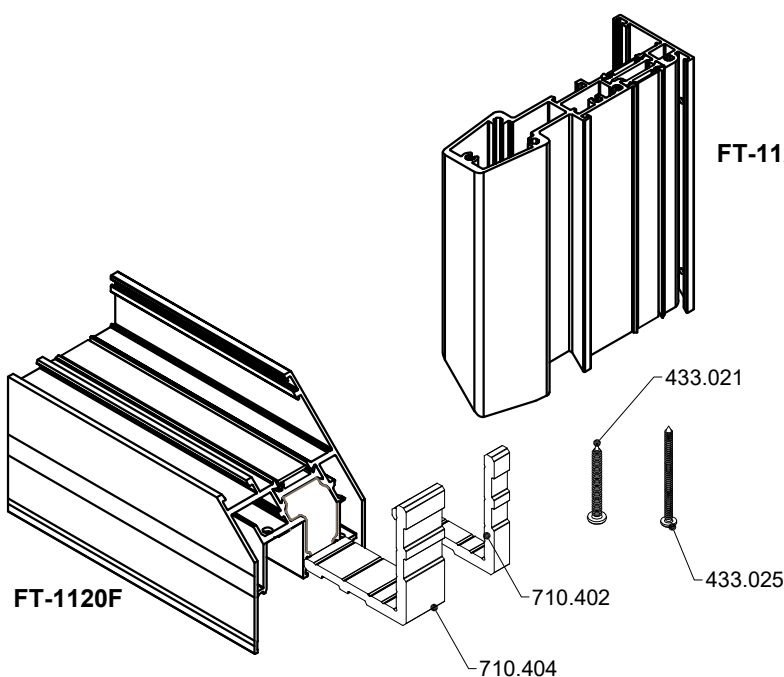

### UGRADNJA POMOĆNE KUTNE 730.017 U KRILO FT-1120F MOUNTING SUPPORT CORNER BRACKET 730.017 IN SASH FT-1120F

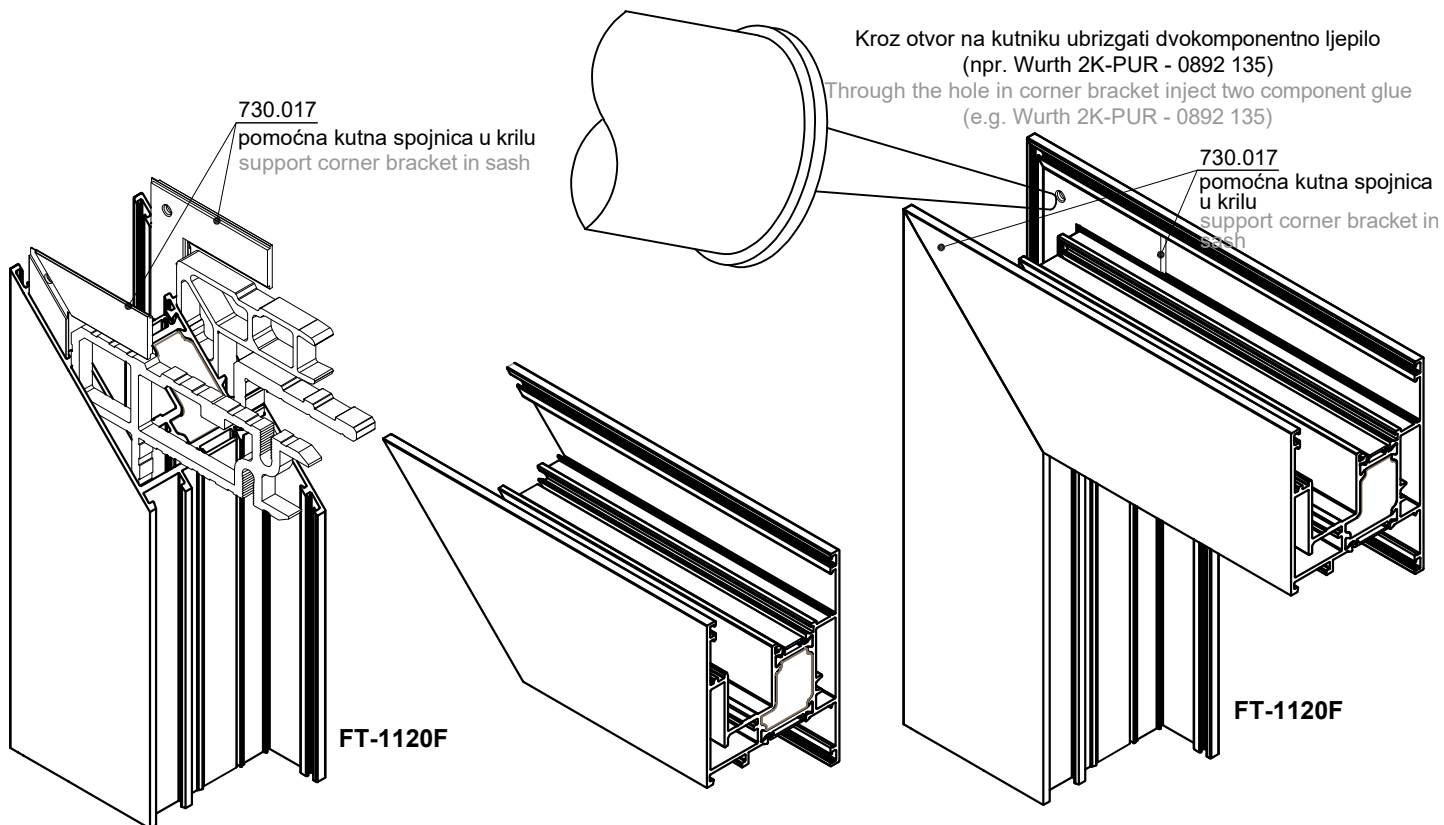

### UGRADNJA POMOĆNE KUTNE 731.010 U KRILO FT-1120F MOUNTING SUPPORT CORNER BRACKET 731.010 IN SASH FT-1120F

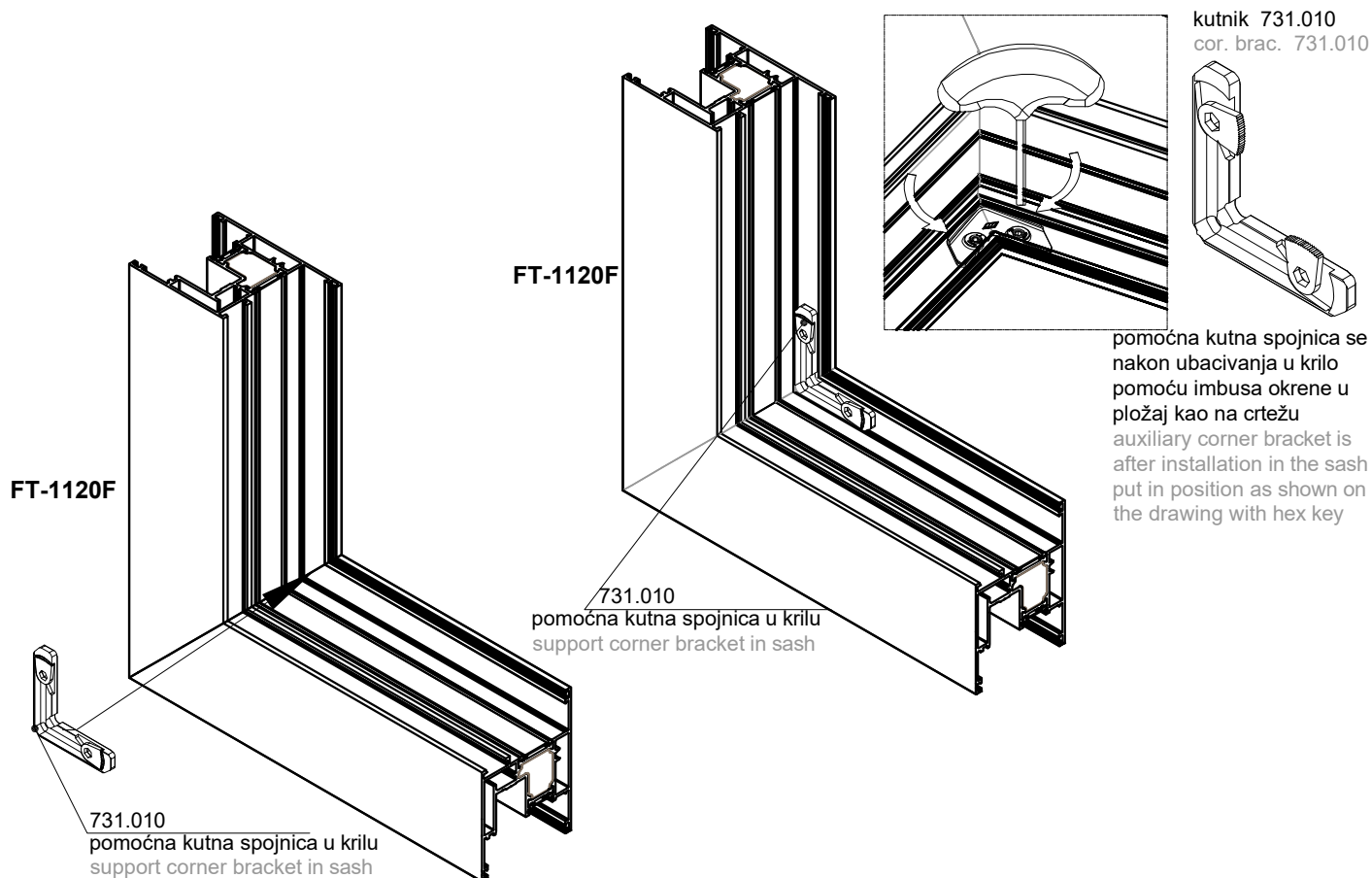

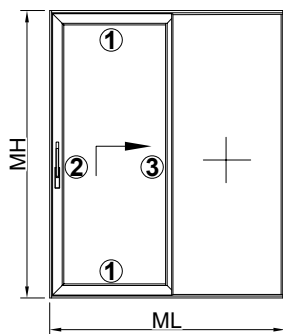
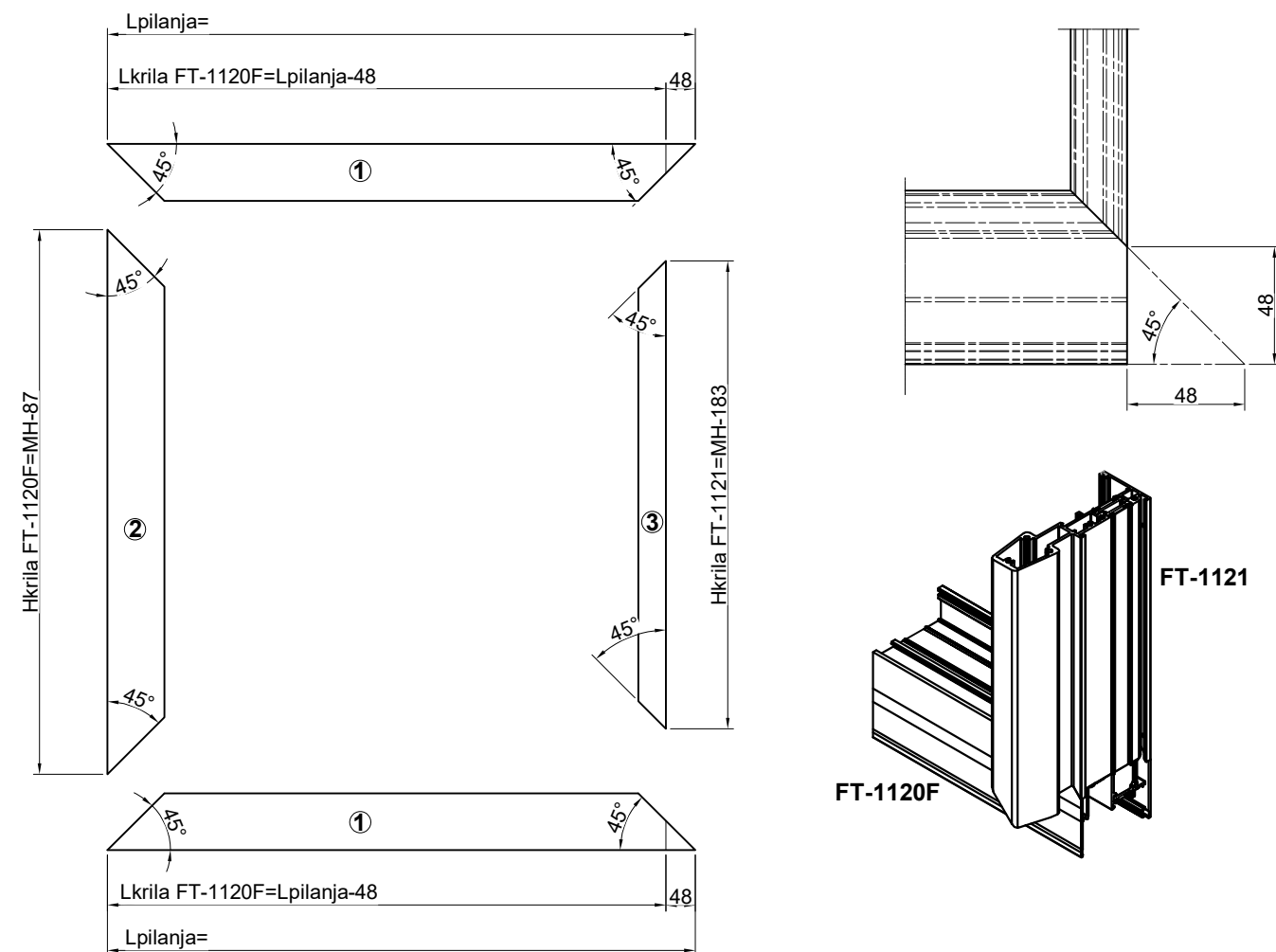

- ①...krilo FT-1120F....Lpilanja=(ML/2)+29.5  
Lkrila=Lpilanja-48
- ②...krilo FT-1120F....Hkrila=MH-87
- ③...krilo FT-1121....Hkrila=MH-183

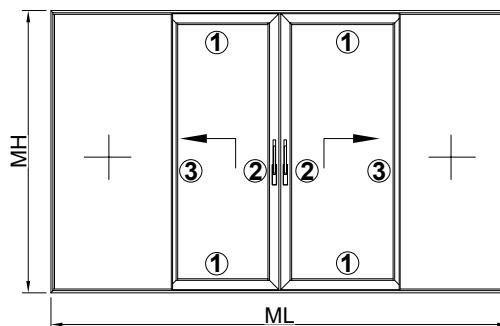

- ①...krilo FT-1120F....Lpilanja=(ML/4)+46  
Lkrila=Lpilanja-48
- ②...krilo FT-1120F....Hkrila=MH-87
- ③...krilo FT-1121....Hkrila=MH-183

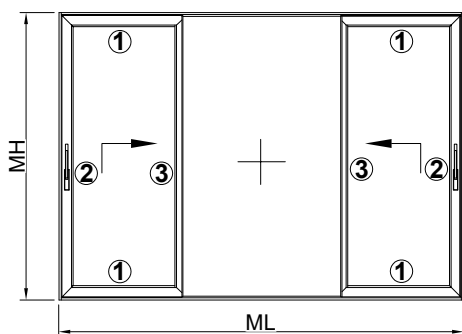

- ①...krilo FT-1120F....Lpilanja=(ML/4)+46  
Lkrila=Lpilanja-48
- ②...krilo FT-1120F....Hkrila=MH-87
- ③...krilo FT-1121....Hkrila=MH-183

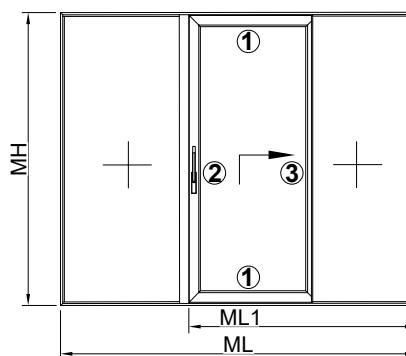

- ①...krilo FT-1120F....Lpilanja=(ML/2)+32.5  
Lkrila=Lpilanja-48
- ②...krilo FT-1120F....Hkrila=MH-87
- ③...krilo FT-1121....Hkrila=MH-183

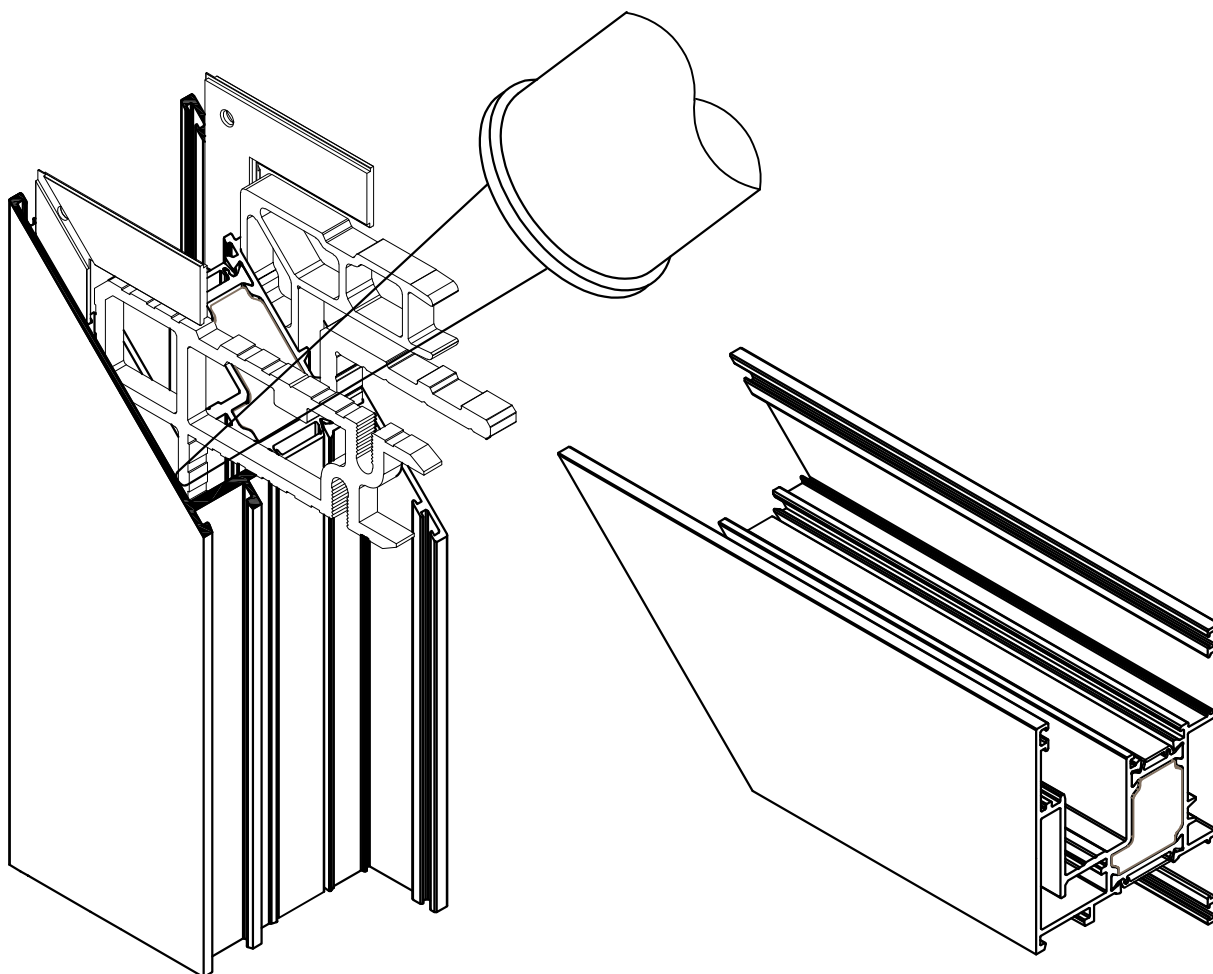
SPAJANJE PROFILA KUTNICIMA POD KUTEM OD 90°  
PROFILES CONNECTION WITH CORNER BRACKET UNDER 90°

## POSTUPAK SPAJANJA PROFILA:

1. Površine koje se spajaju-rezove očistiti i odmastiti prikladnim sredstvom /npr. Sika Remover 208; Wurth-kat.br.:892 130 30/.
2. Premazati površine koje se spajaju ljepilom za metal /npr. Sika Force 7851; Wurth-kat.br.:892 130 010/.
3. Ljepilo za metal ušpricati u komore za kutnik (po opsegu komore)
4. Profile s kutnicima izravnati i spojiti
5. Dio ljepila koji iscuri između rezova očistiti sredstvom za čišćenje i odmašćivanje /npr. Sika Remover 208; Wurth-kat.br.:892 130 30/.

## NAPOMENA:

Ovaj postupak spajanja profila primjenjiv je za sve Feal-ove kutnike i njima odgovarajuće komore. Lijepljenjem rezova i kutnika ljepilima za metal osigurava se potrebna zrako- i vodonepropusnosti spoja kao i dodatna mehanička čvrstoća spoja.

## PROFILE CONNECTION PROCEDURE:

1. Surfaces that are connecting - clean and degrease the cut with suitable products /e.g. Sika Remover 208; Wurth-kat. no.:892 130 30/.
2. Smear surfaces that are connecting with metal glue /e.g. Sika Force 7851; Wurth-kat.no.:892 130 010/.
3. Spurt metal glue into chambers for the corner bracket (on chamber circumference)
4. Level profiles with corner brackets and connect
5. Leaking glue that comes from the joints remove with cleaning and degrease product /e.g. Sika Remover 208; Wurth-kat.no.:892 130 30/.

## REMARK:

This profile connection procedure is applicable for all Feal corner brackets and their appropriate chambers. Gluing cuts and corners with metal glues provides necessary air and water tightness of the joint and additional mechanical properties.

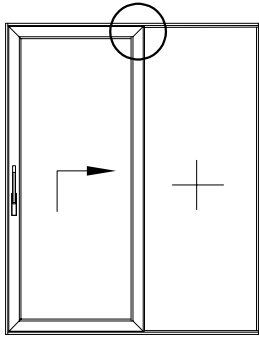

- Obrada al profila prečke FT-1130F prema profilu rama FT-1101F (spajanje vijcima 4.2x38 DIN 7981)
- Processing of al mullion profile FT-1130F towards frame profile FT-1101F (connection with screws 4.2x38 DIN 7981)

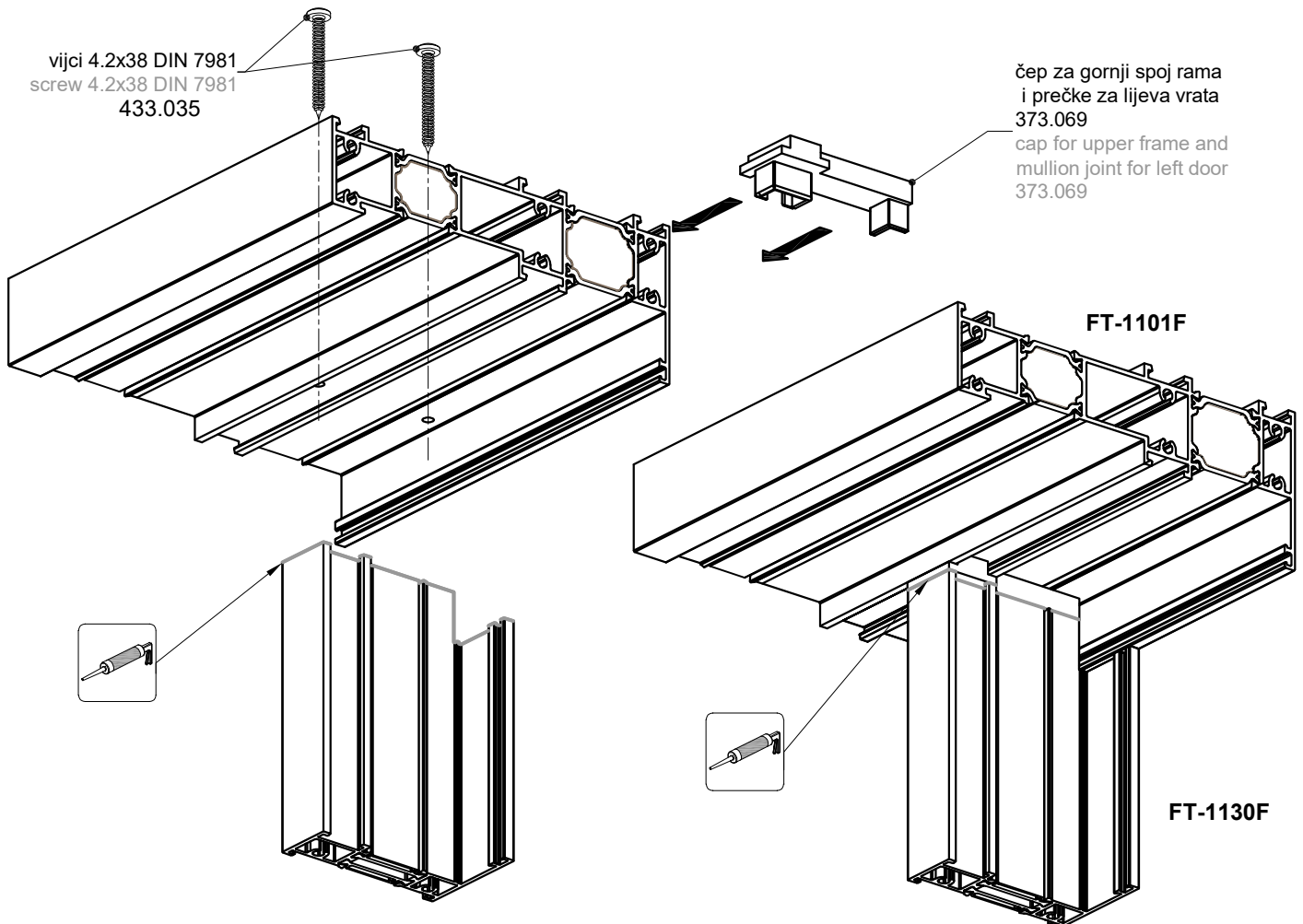
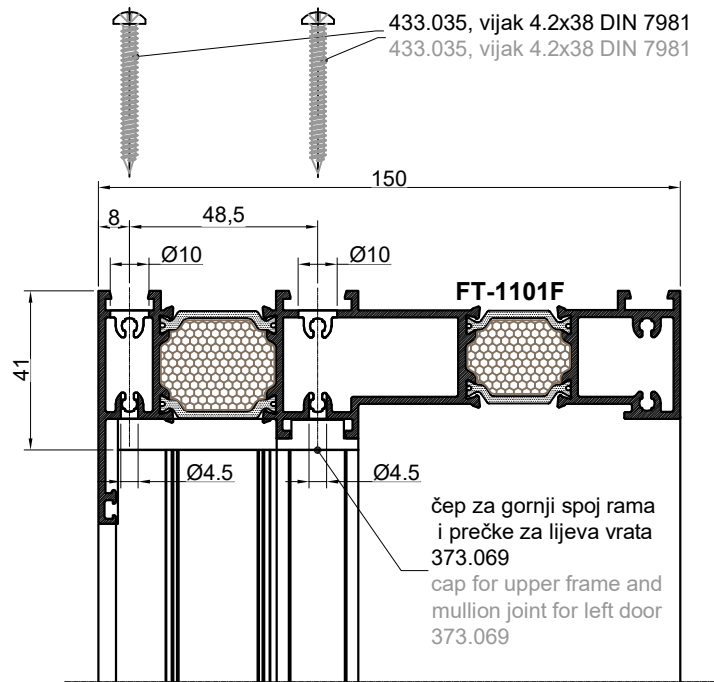
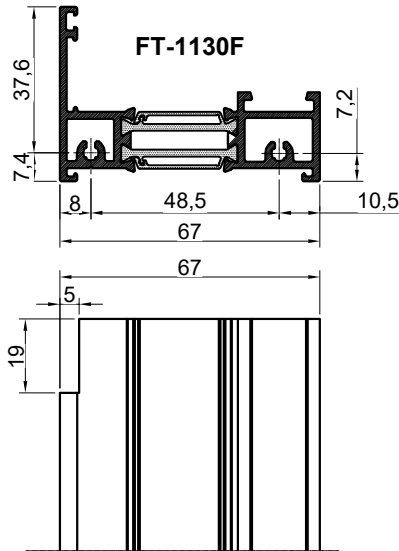

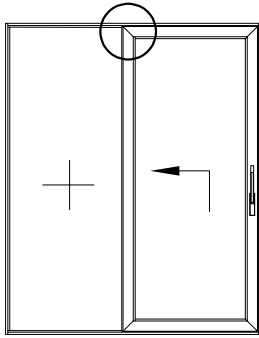

- Obrada al profila prečke FT-1130F prema profilu rama FT-1101F (spajanje vijcima 4.2x38 DIN 7981)
- Processing of al mullion profile FT-1130F towards frame profile FT-1101F (connection with screws 4.2x38 DIN 7981)

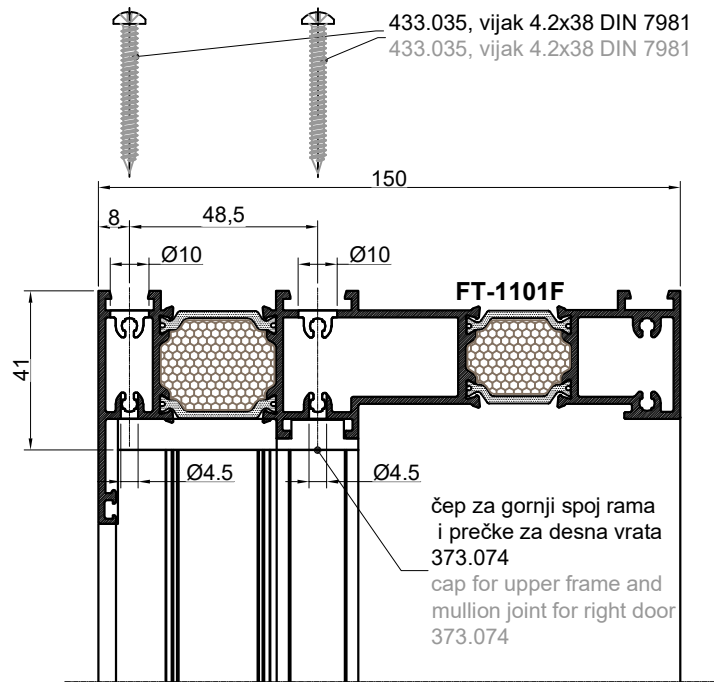
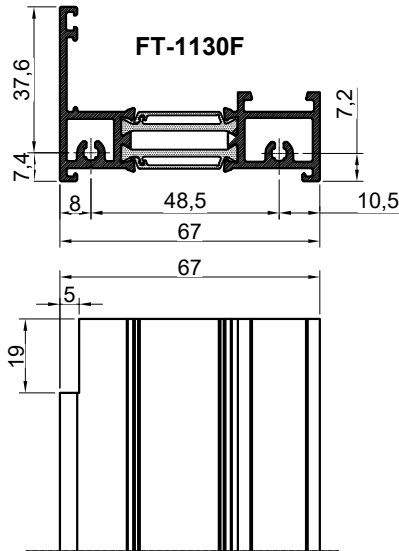

čep za gornji spoj rama  
i prečke za desna vrata  
373.074  
cap for upper frame and  
mullion joint for right  
door  
373.074

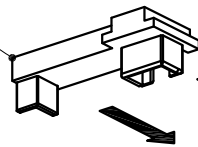

vijci 4.2x38 DIN 7981  
screw 4.2x38 DIN 7981  
433.035

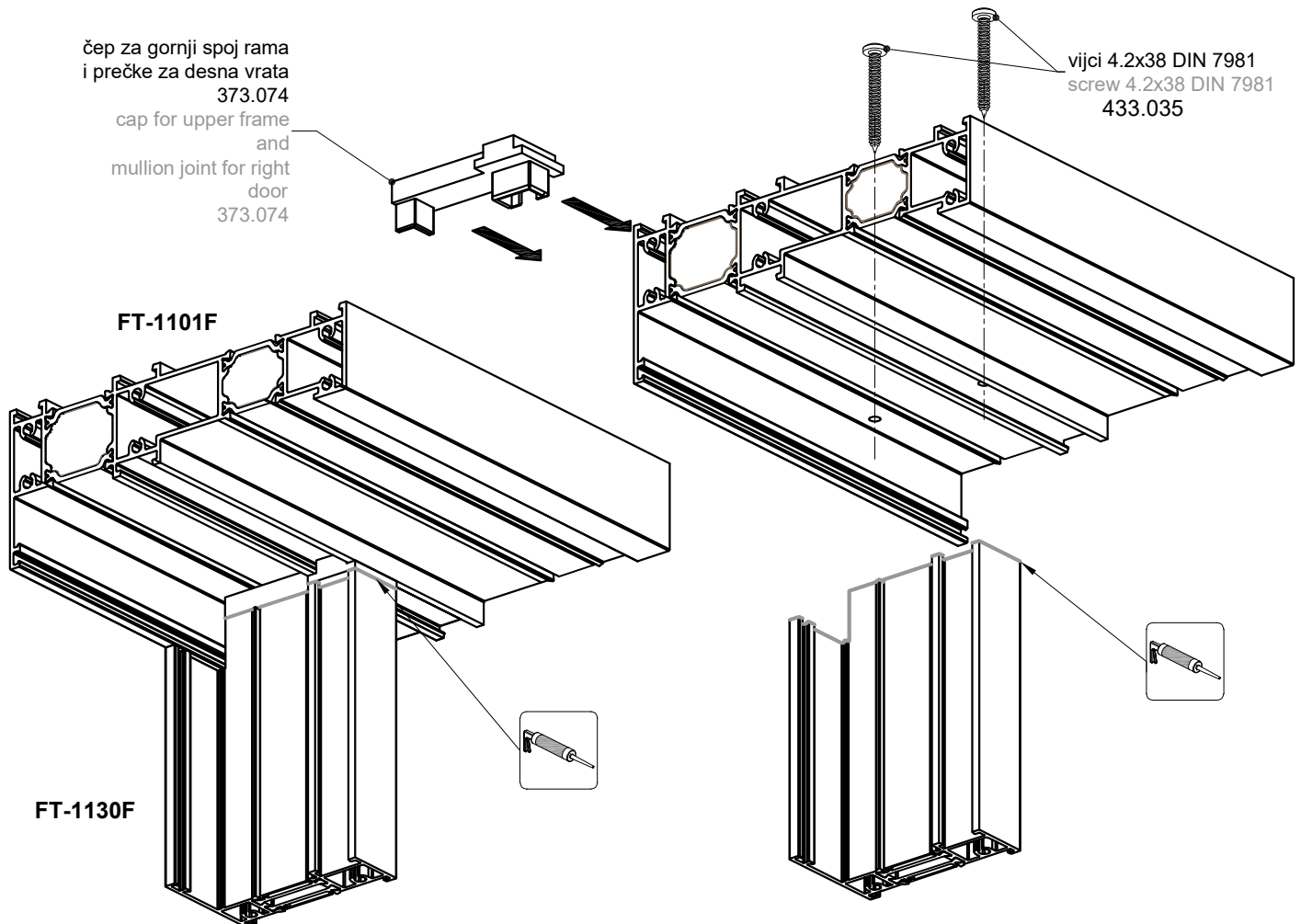

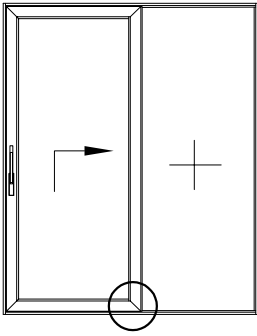

- Obrada al profila prečke FT-1130F prema profilu rama FT-1102F (spajanje vijcima 4.2x38 DIN 7981, 4.2x25 DIN 7981)
- Processing of al mullion profile FT-1130F towards frame profile FT-1102F (connection with screws 4.2x38 DIN 7981, 4.2x25 DIN 7981)

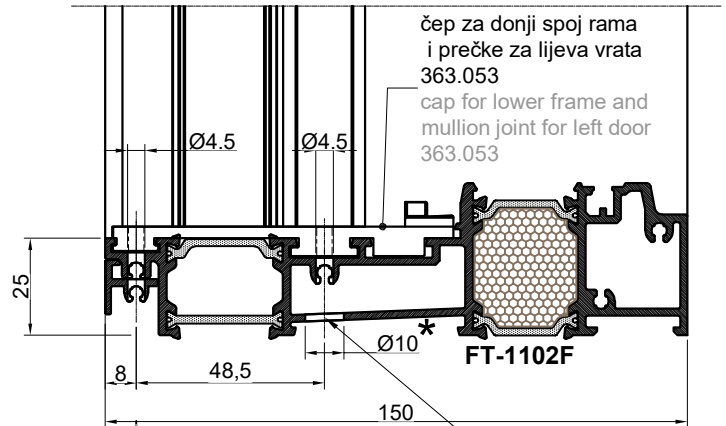
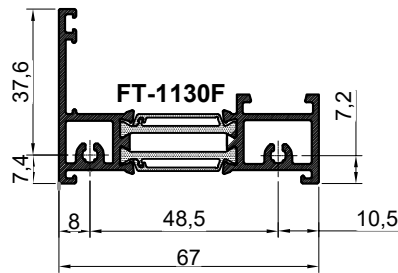
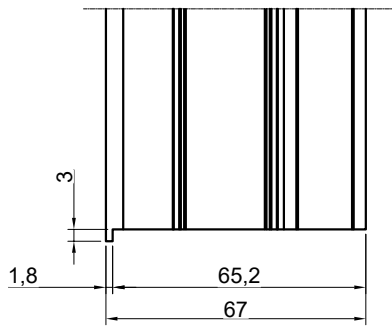

433.035,  
vijak 4.2x38  
DIN 7981  
433.035,  
screw 4.2x38  
DIN 7981

433.032,  
vijak 4.2x25  
DIN 7981  
433.032,  
screw 4.2x25  
DIN 7981



nakon montaže  
vijka silikonirati  
otvor  
after montage of  
the cap, siliconize  
hole

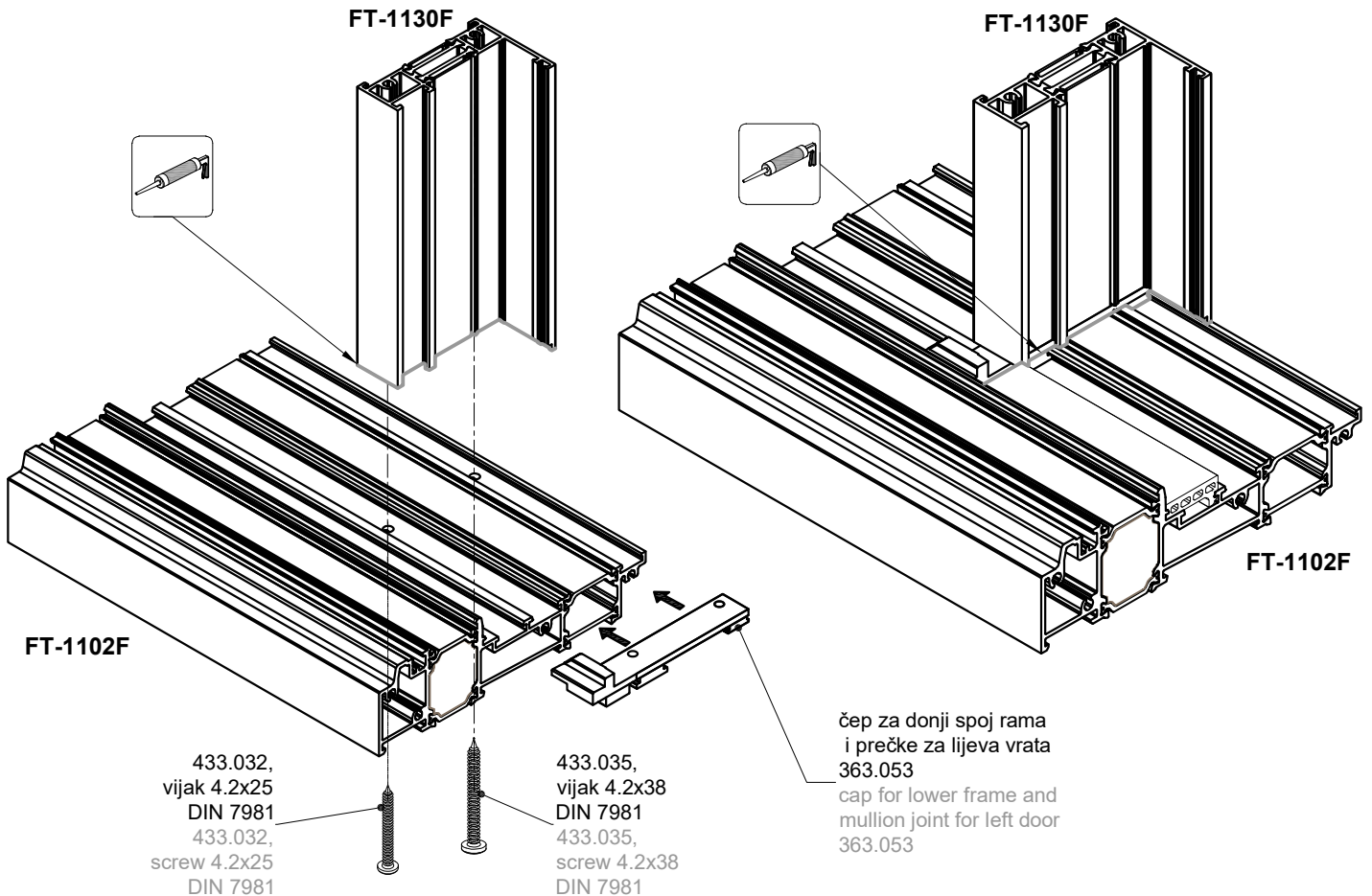

433.032,  
vijak 4.2x25  
DIN 7981  
433.032,  
screw 4.2x25  
DIN 7981

433.035,  
vijak 4.2x38  
DIN 7981  
433.035,  
screw 4.2x38  
DIN 7981

čep za donji spoj rama  
i prečke za lijeva vrata  
363.053  
cap for lower frame and  
mullion joint for left door  
363.053

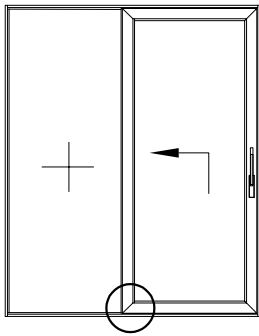

- Obrada al profila prečke FT-1130F prema profilu rama FT-1102F (spajanje vijcima 4.2x38 DIN 7981, 4.2x25 DIN 7981)
- Processing of al mullion profile FT-1130F towards frame profile FT-1102F (connection with screws 4.2x38 DIN 7981, 4.2x25 DIN 7981)

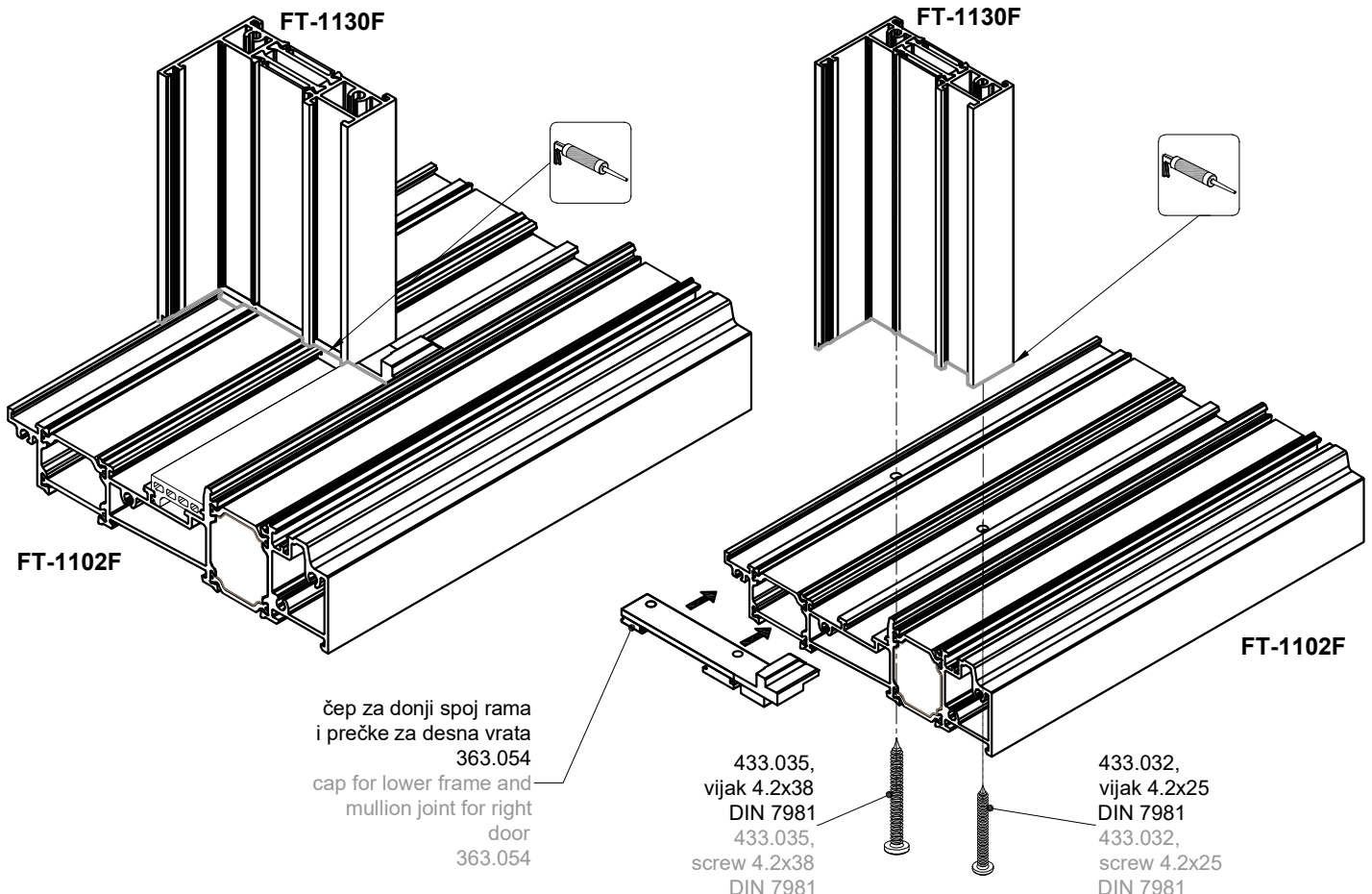
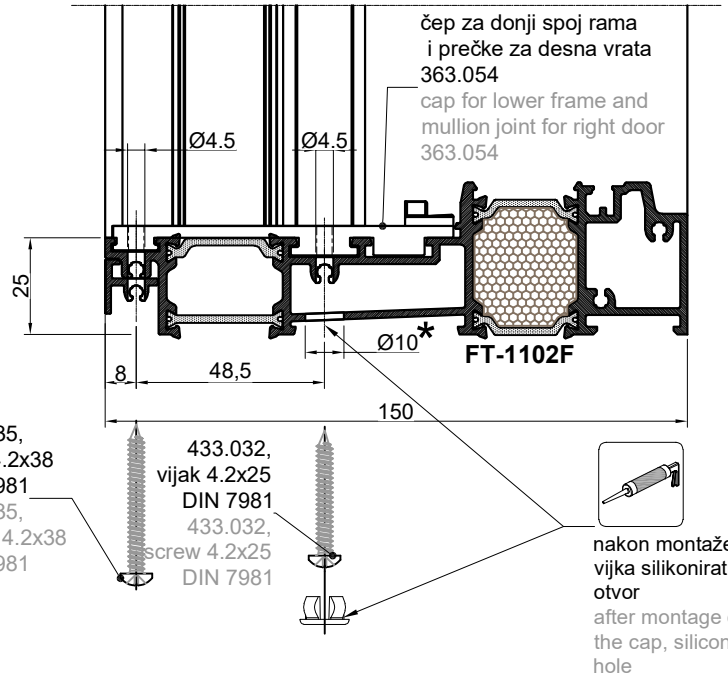
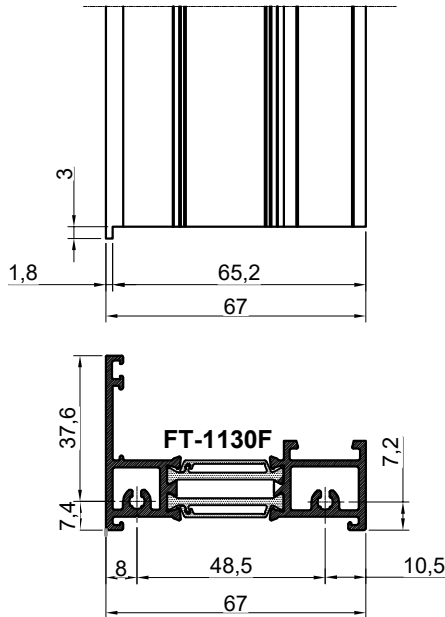

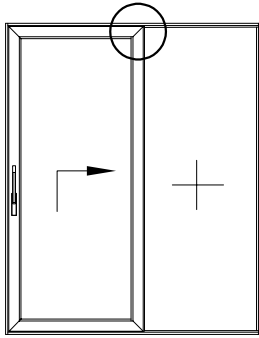

- Obrada al profila prečke FT-1131F prema profilu rama FT-1101F (spajanje vijcima 4.2x50 DIN 7981)
- Processing of al mullion profile FT-1131F towards frame profile FT-1101F (connection with screws 4.2x50 DIN 7981)

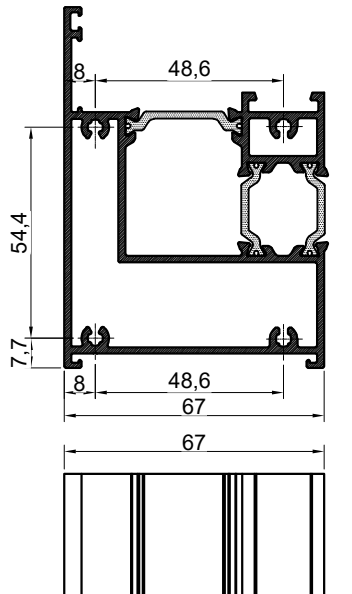

FT-1131F

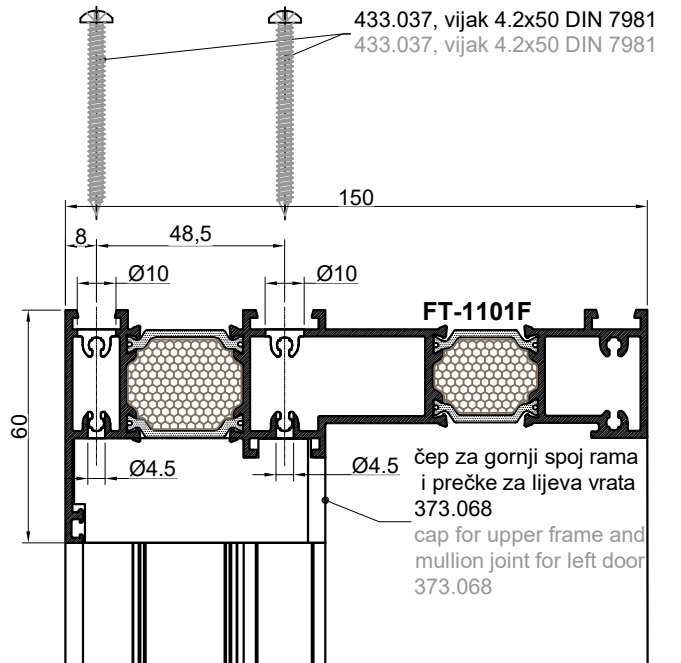

čep za gornji spoj rama i prečke za lijeva vrata 373.068  
cap for upper frame and mullion joint for left door 373.068

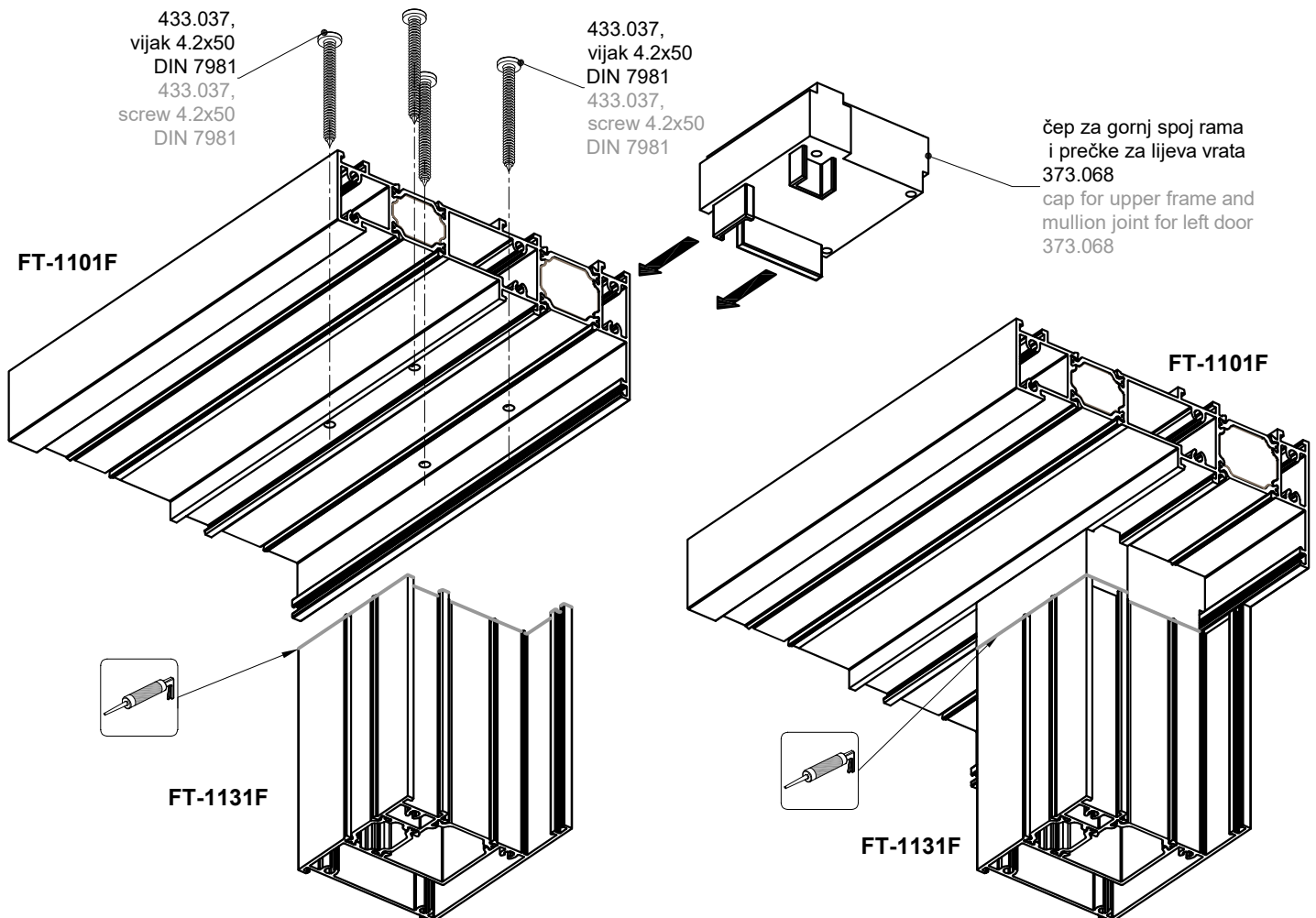

433.037, vijak 4.2x50 DIN 7981  
433.037, screw 4.2x50 DIN 7981

433.037, vijak 4.2x50 DIN 7981  
433.037, screw 4.2x50 DIN 7981

čep za gornji spoj rama i prečke za lijeva vrata 373.068  
cap for upper frame and mullion joint for left door 373.068

FT-1101F

FT-1101F

FT-1131F

FT-1131F

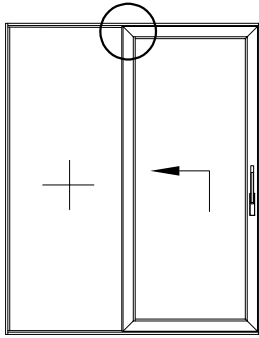

- Obrada al profila prečke FT-1131F prema profilu rama FT-1101F (spajanje vijcima 4.2x50 DIN 7981)
- Processing of al mullion profile FT-1131F towards frame profile FT-1101F (connection with screws 4.2x50 DIN 7981)

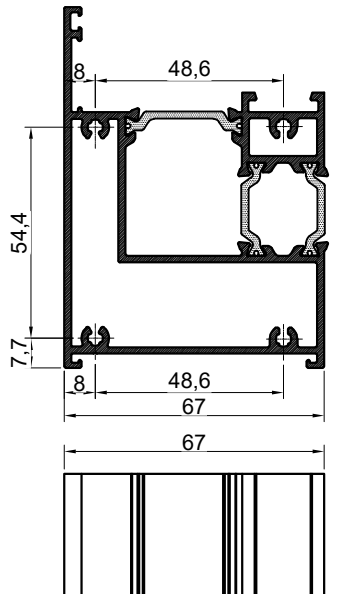

FT-1131F

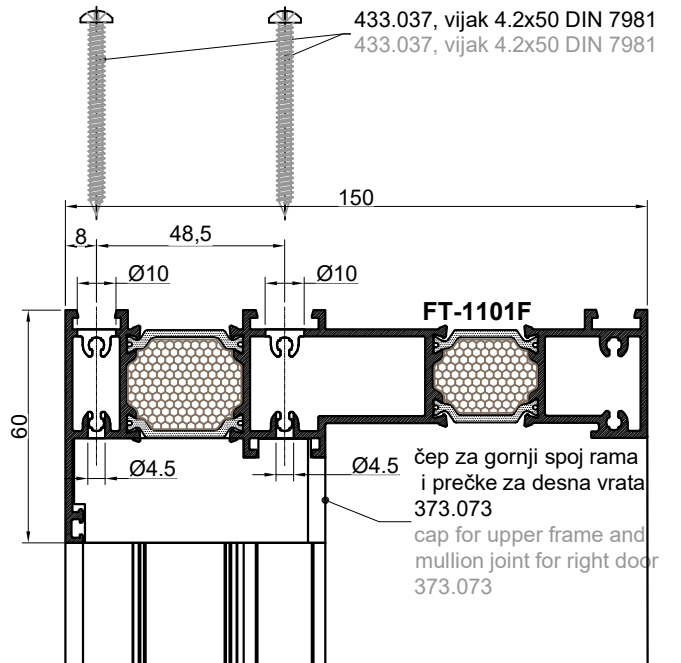

čep za gornji spoj rama i prečke za desna vrata  
373.073  
cap for upper frame and mullion joint for right door  
373.073

čep za gornji spoj rama i prečke za desna vrata  
373.073  
cap for upper frame and mullion joint for right door  
373.073

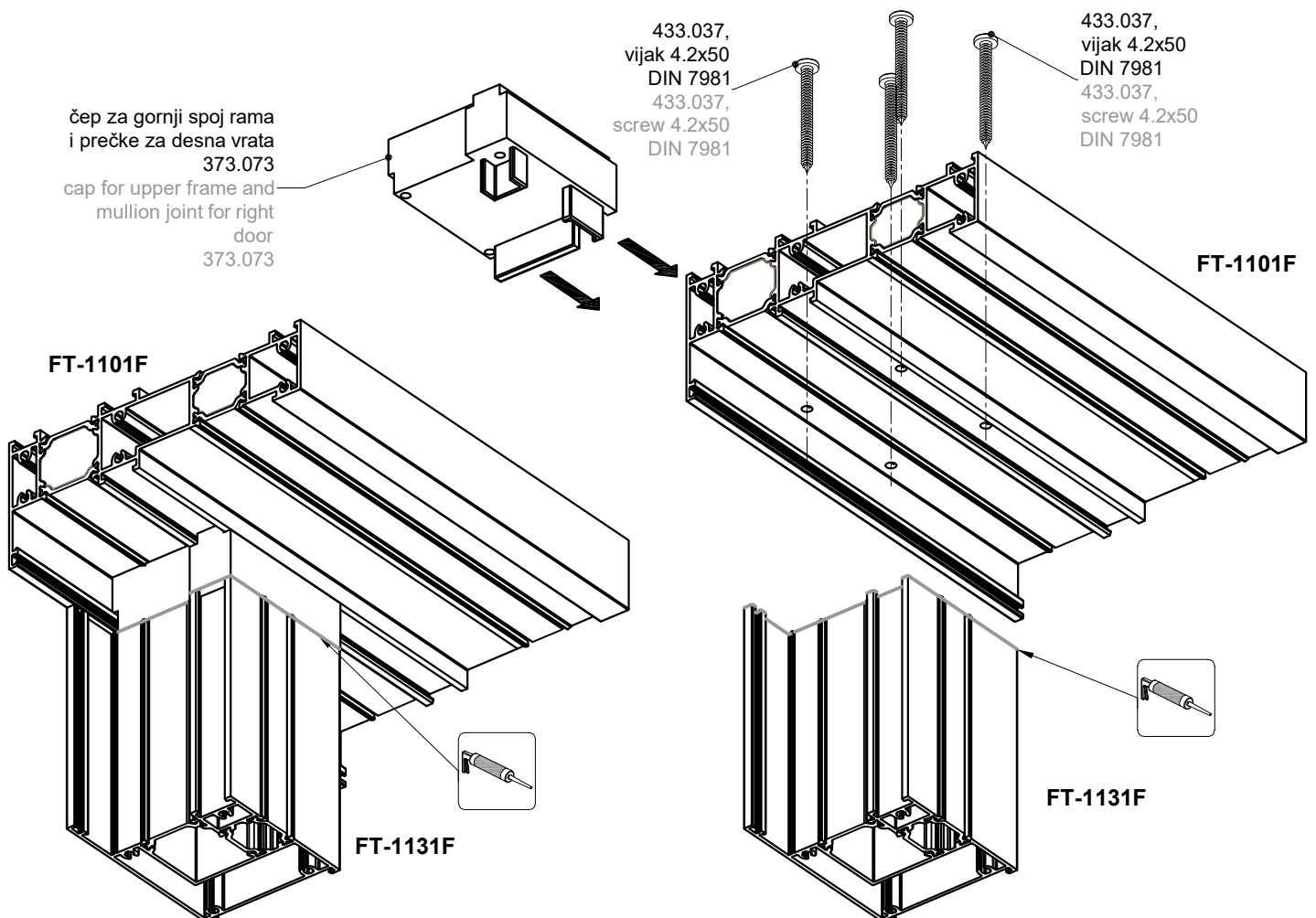

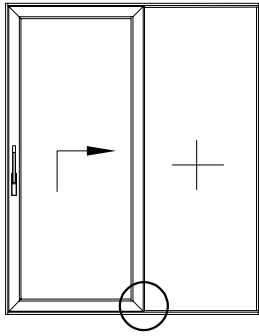

- Obrada al profila prečke FT-1131F prema profilu rama FT-1102F (spajanje vijcima 4.2x38 DIN 7981, 4.2x32 DIN 7981)
- Processing of al mullion profile FT-1131F towards frame profile FT-1102F (connection with screws 4.2x38 DIN 7981, 4.2x32 DIN 7981)

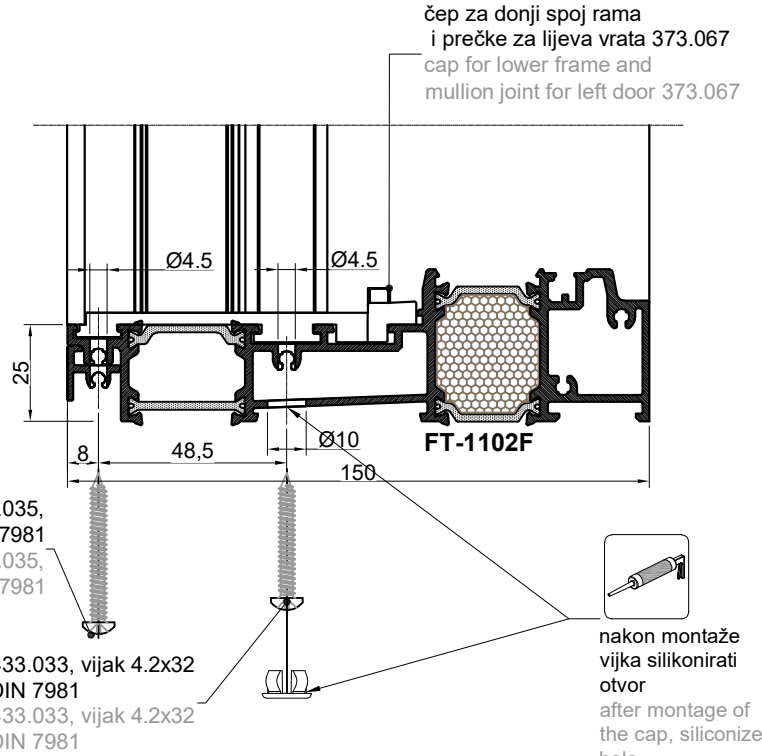
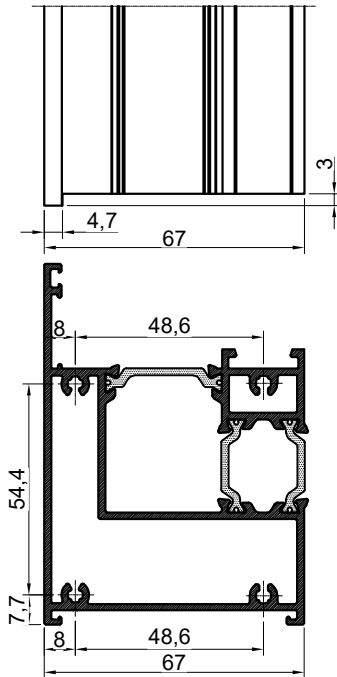

433.035,  
vijak 4.2x38 DIN 7981  
433.035,  
vijak 4.2x38 DIN 7981

**FT-1131F**

433.033, vijak 4.2x32  
DIN 7981  
433.033, vijak 4.2x32  
DIN 7981

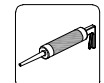

nakon montaže  
vijka silikonirati  
otvor  
after montage of  
the cap, silicone  
hole

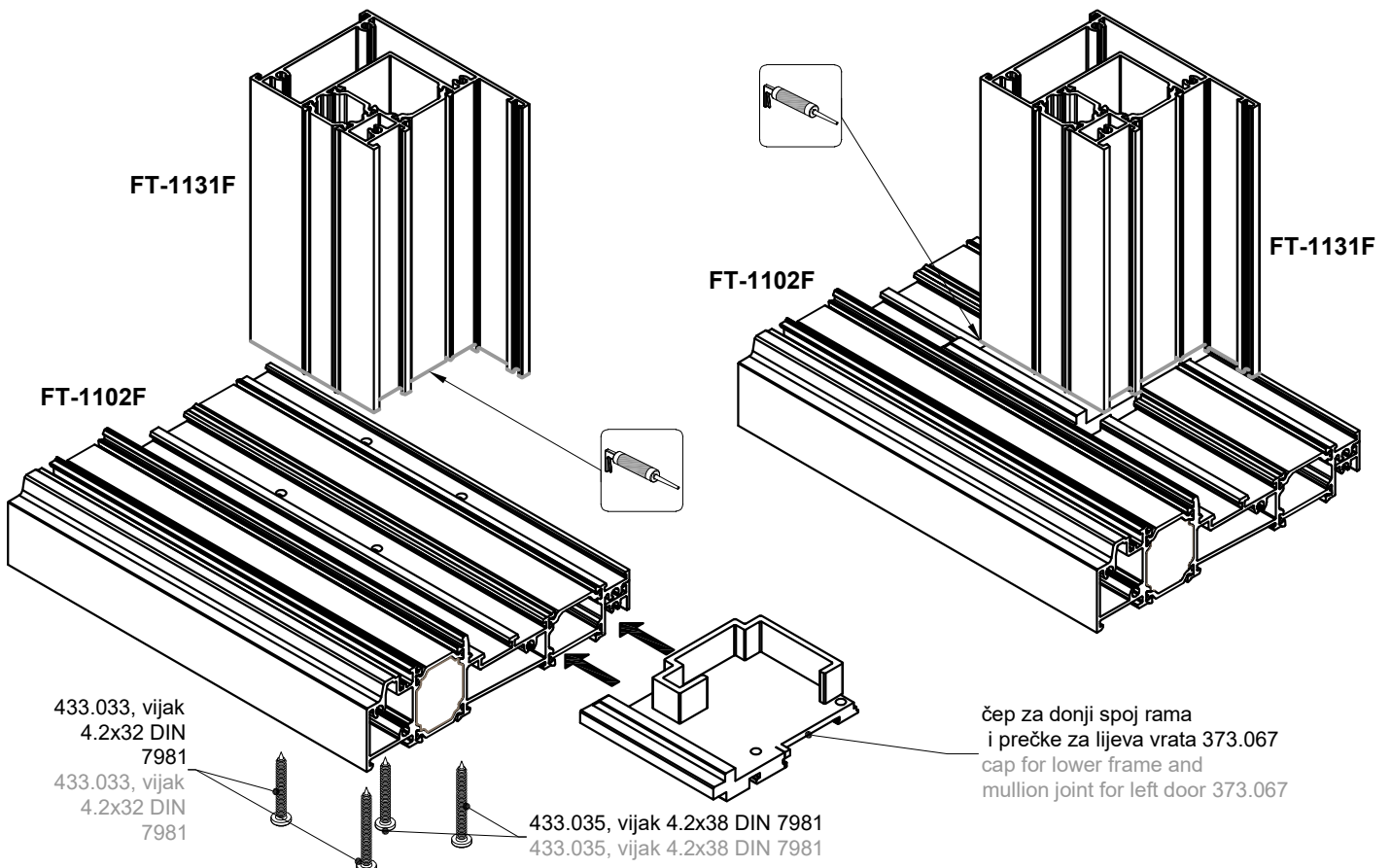

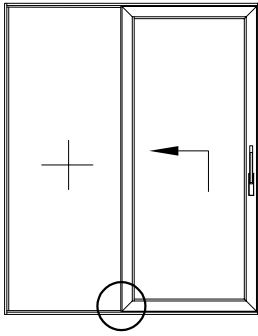

- Obrada al profila prečke FT-1131F prema profilu rama FT-1102F (spajanje vijcima 4.2x38 DIN 7981, 4.2x32 DIN 7981)
- Processing of al mullion profile FT-1131F towards frame profile FT-1102F (connection with screws 4.2x38 DIN 7981, 4.2x32 DIN 7981)

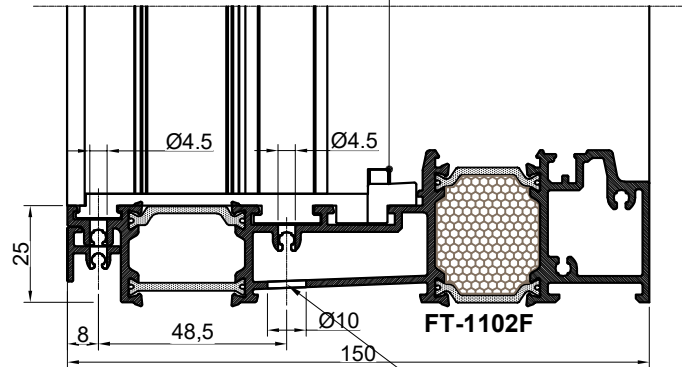
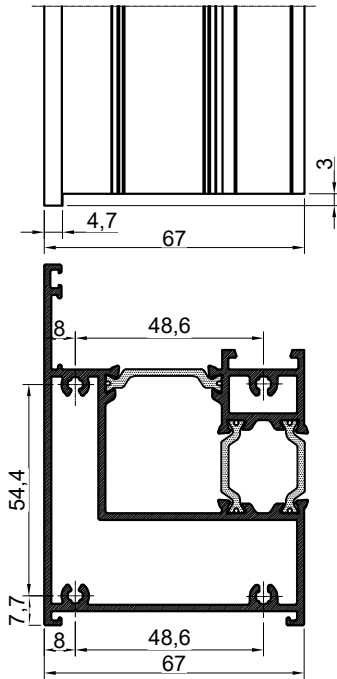

čep za donji spoj rama  
i prečke za desna vrata 373.072  
cap for lower frame and  
mullion joint for right door  
373.072

**FT-1131F**

433.035,  
vijak 4.2x38 DIN 7981  
433.035,  
vijak 4.2x38 DIN 7981

433.033,  
vijak 4.2x32 DIN 7981  
433.033,  
vijak 4.2x32 DIN 7981



nakon montaže  
vijka silikonirati  
otvor  
after montage of  
the cap, siliconize  
hole

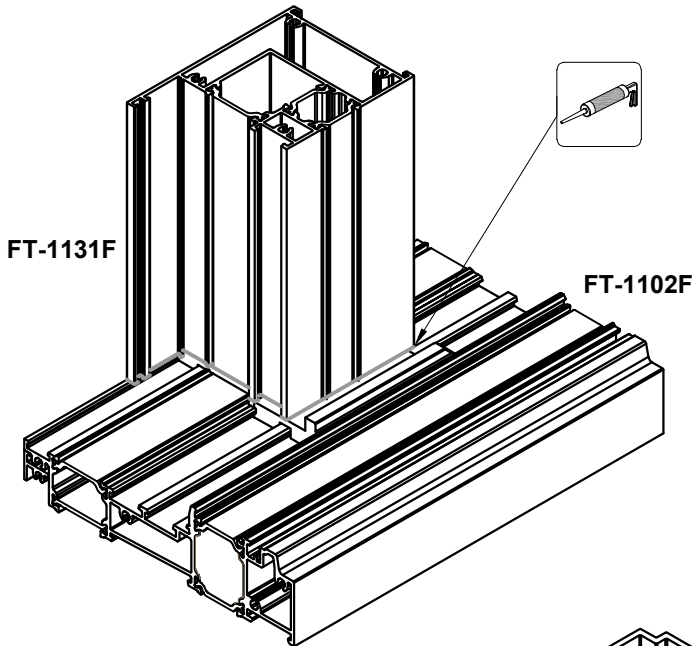

**FT-1131F**

**FT-1102F**

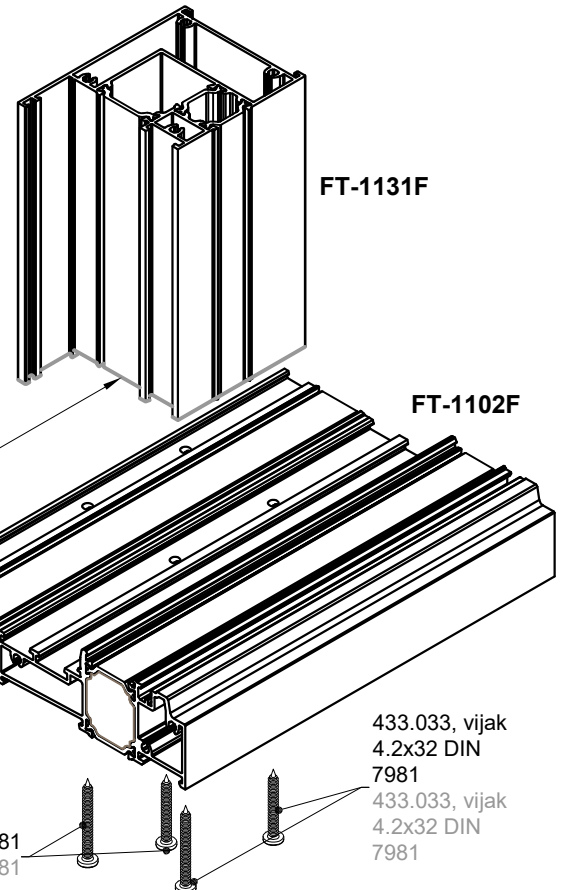

**FT-1131F**

**FT-1102F**

čep za donji spoj rama  
i prečke za desna vrata 373.072  
cap for lower frame and  
mullion joint for right door  
373.072

433.035, vijak 4.2x38 DIN 7981  
433.035, vijak 4.2x38 DIN 7981

433.033, vijak  
4.2x32 DIN  
7981  
433.033, vijak  
4.2x32 DIN  
7981

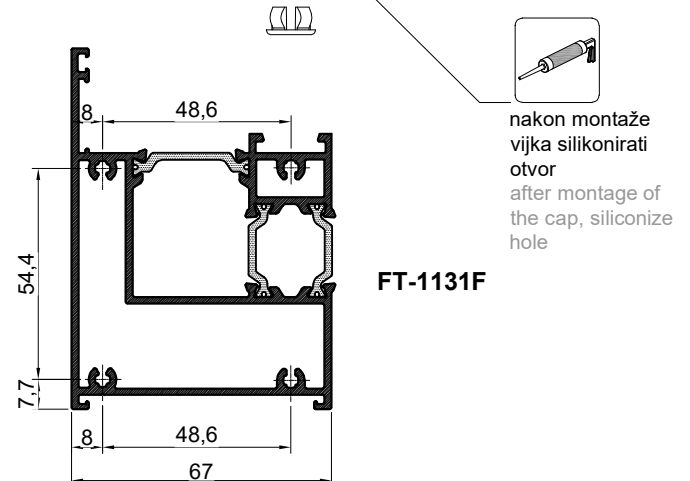
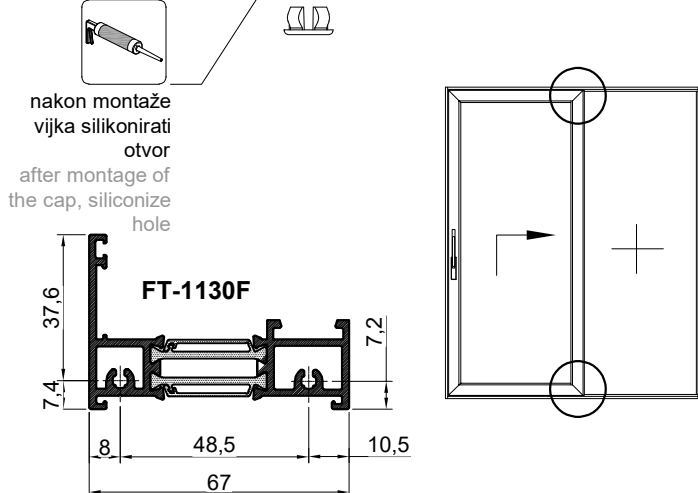
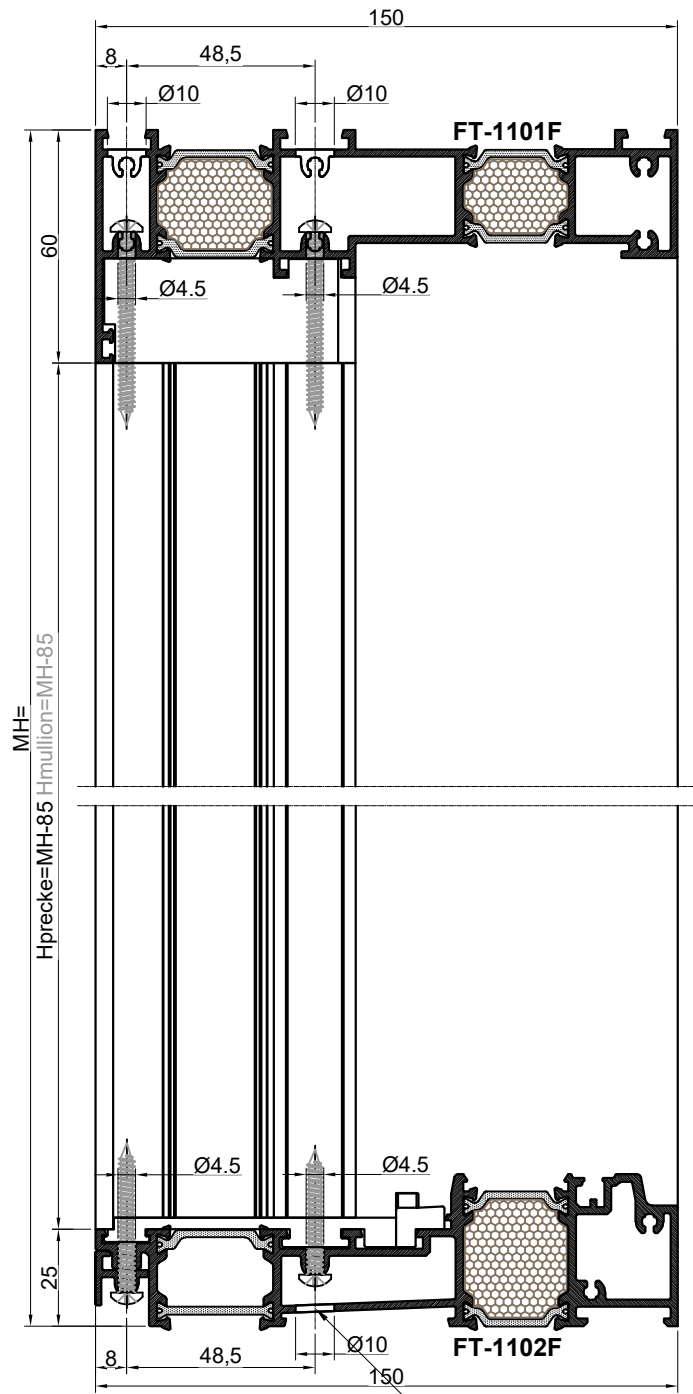
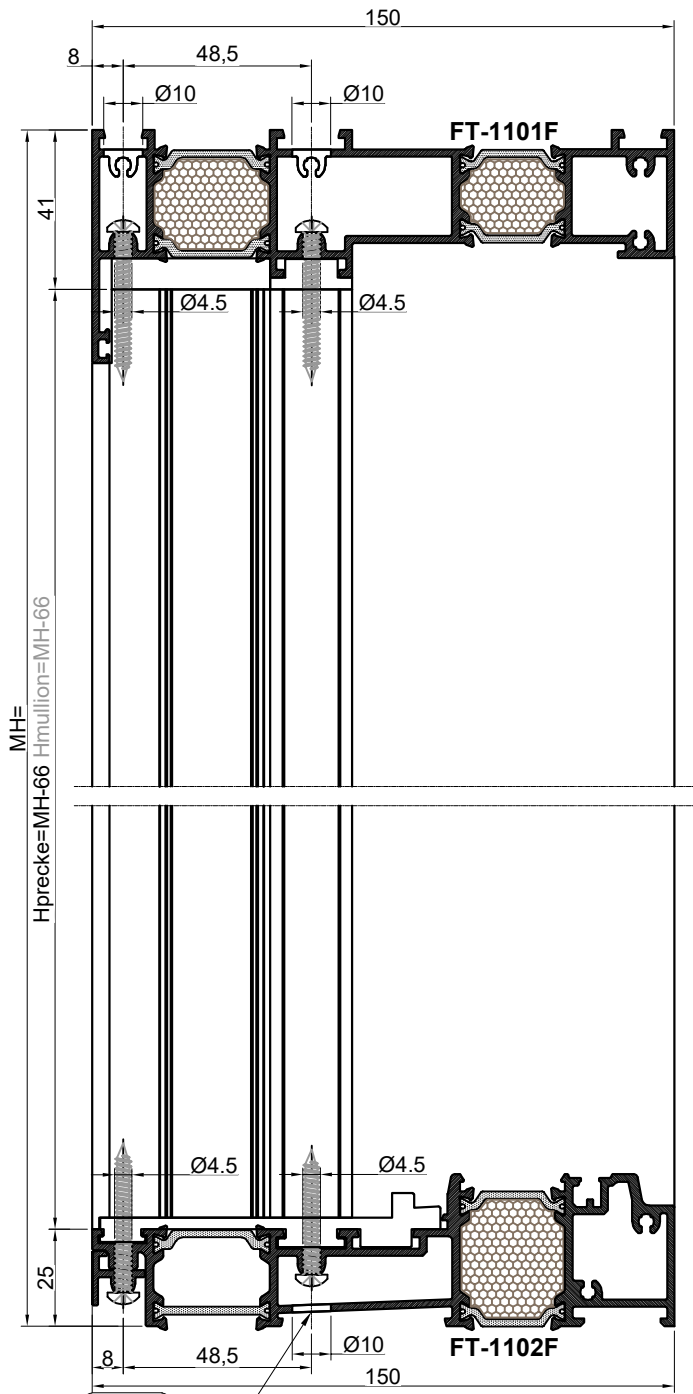

nakon montaže  
vijka silikonirati  
otvor  
after montage of  
the cap, siliconize  
hole

nakon montaže  
vijka silikonirati  
otvor  
after montage of  
the cap, siliconize  
hole

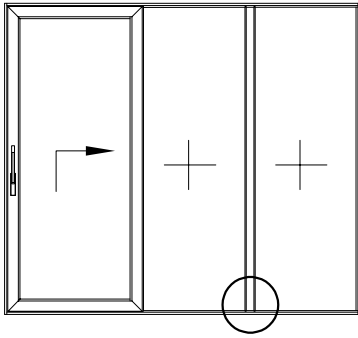

- Obrada al profila prečke FT-1136 F prema profilu rama FT-1102 F (spajanje veznicima 710.538 i 710.543)
- Processing of al mullion profile FT-1136F towards frame profile FT-1102F (connection with 710.538 and 710.543)

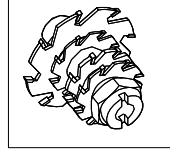

220.031

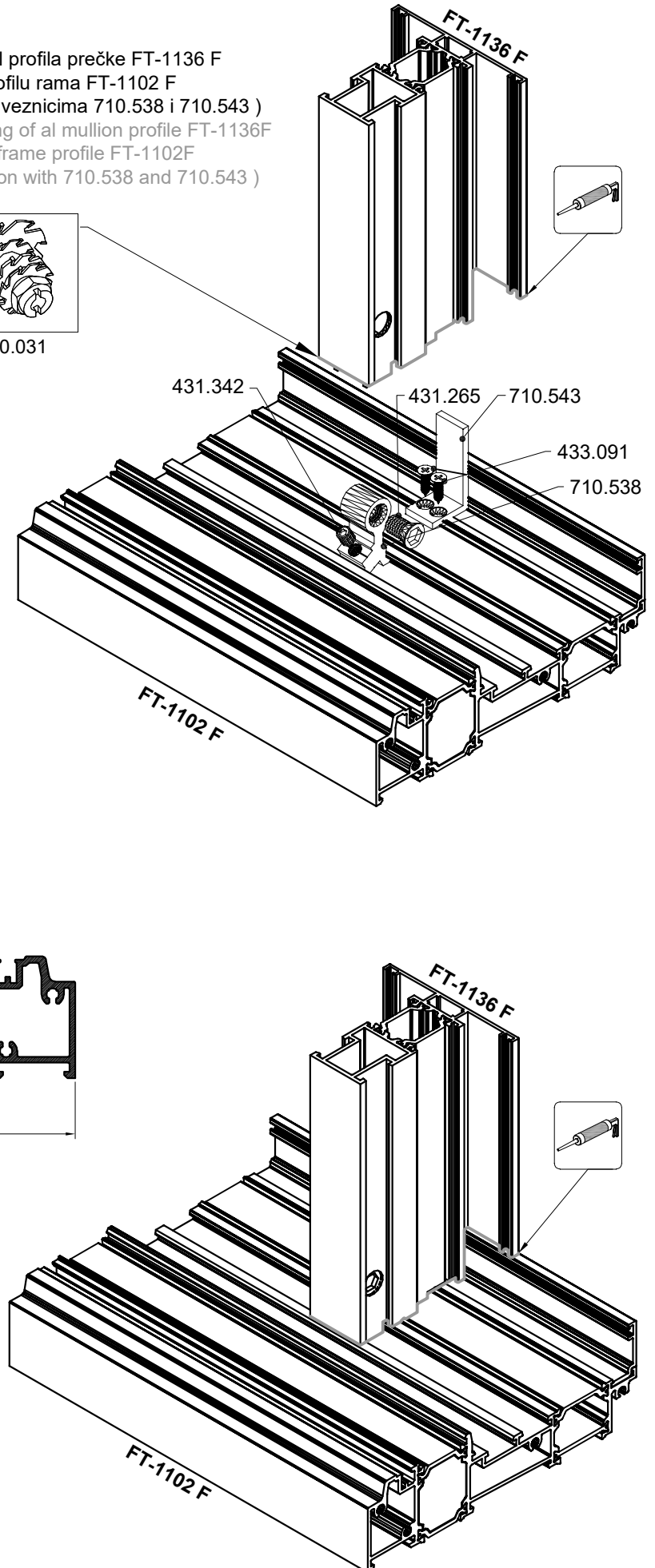
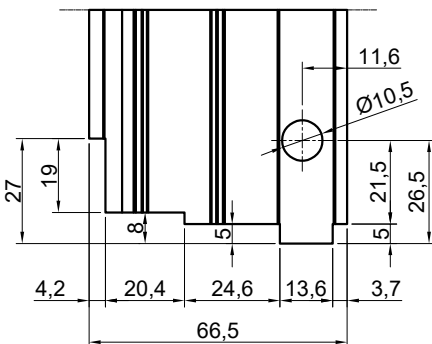
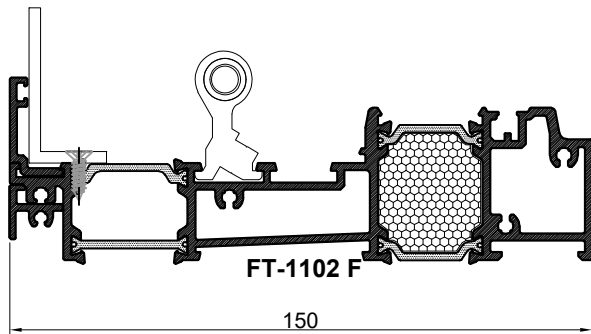
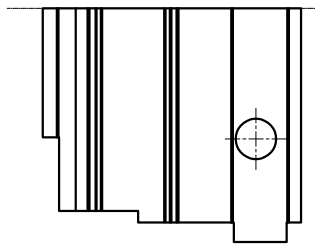
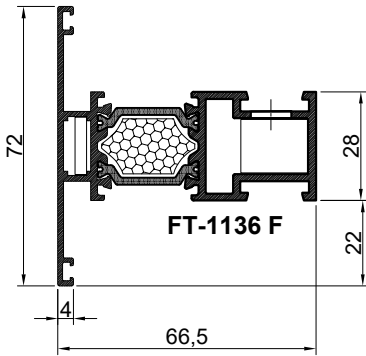

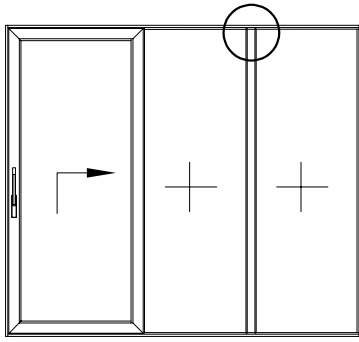

- Obrada al profila prečke FT-1136 F prema profilu rama FT-1101 F (spajanje veznicima 710.538 i 710.212 )
- Processing of al mullion profile FT-1136F towards frame profile FT-1101F (connection with 710.538 and 710.212 )

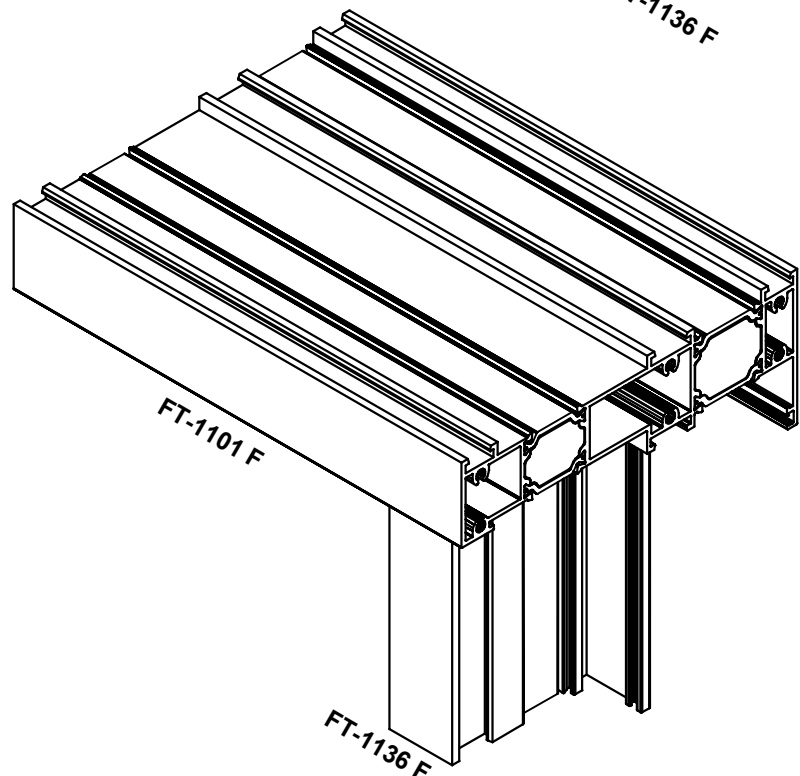
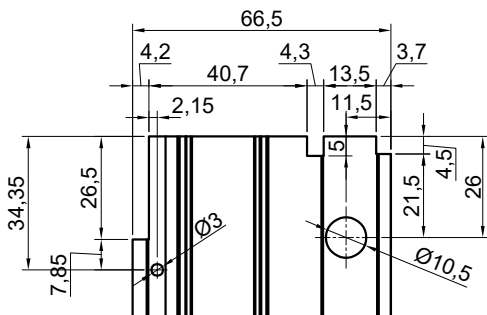
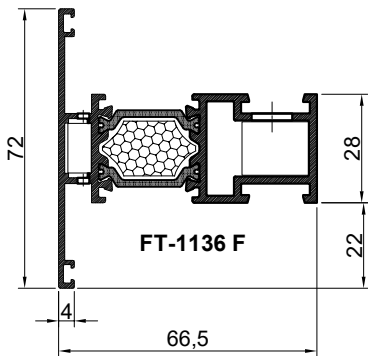
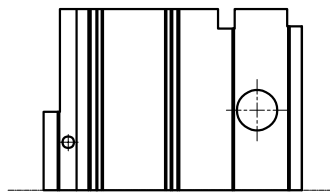
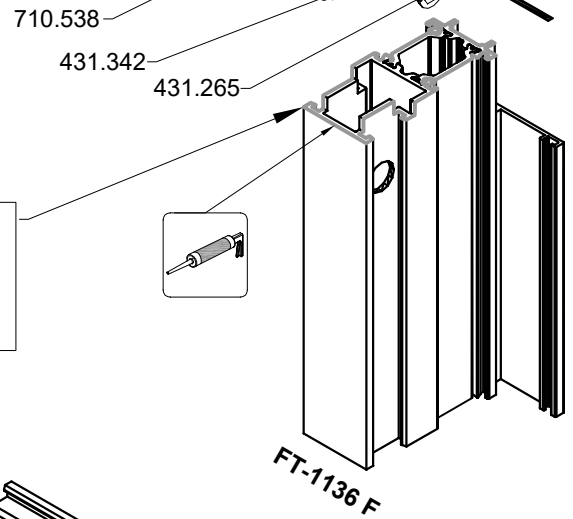
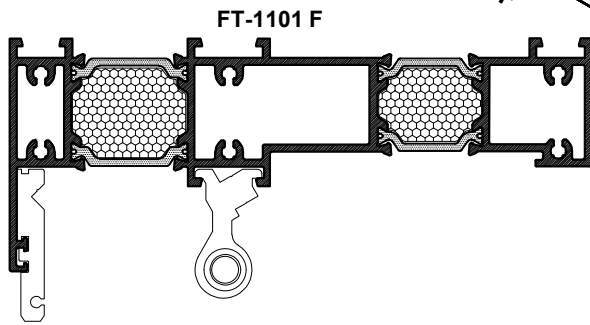
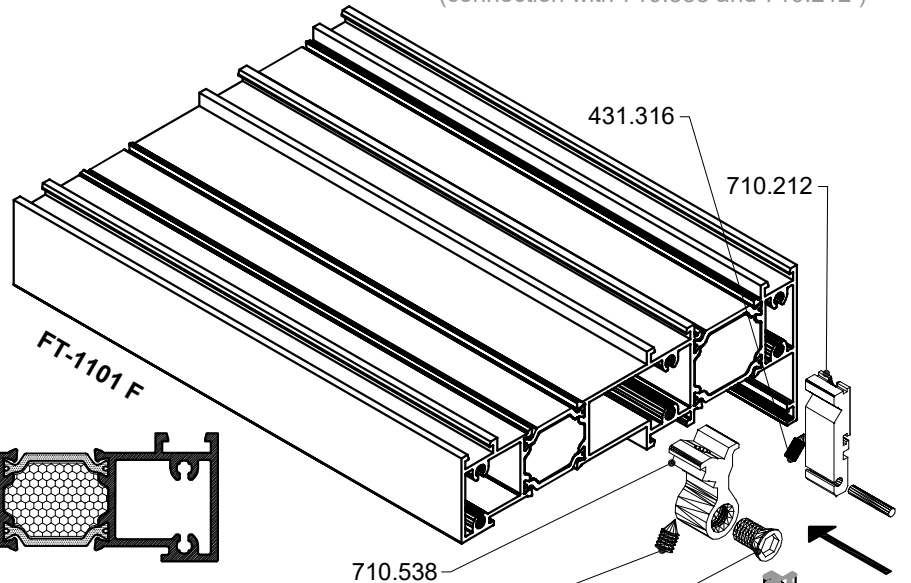

- Obrada al profila prečke FT-1135F prema profilu rama FT-1101F (spajanje vijcima 4.2x25 DIN 7981)  
Processing of al mullion profile FT-1135F towards frame profile FT-1101F (connection with screws)

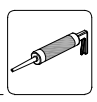
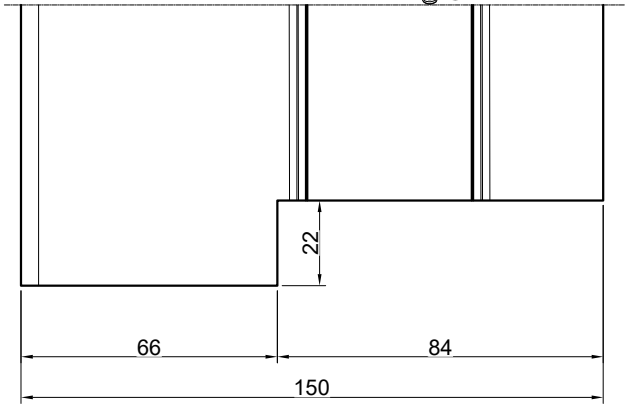
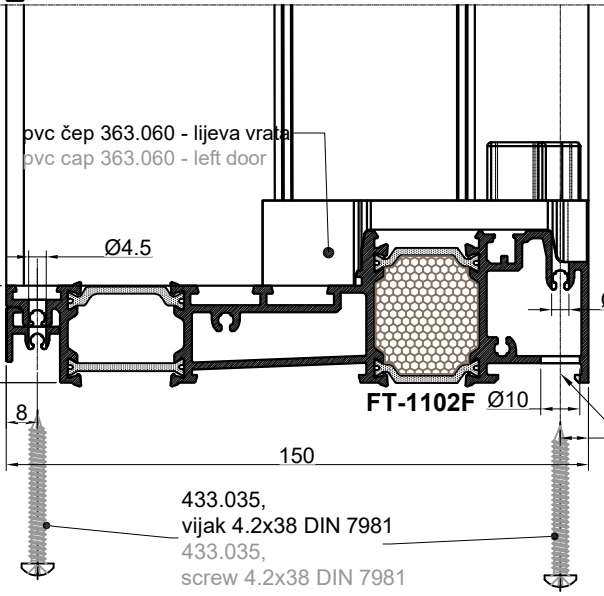
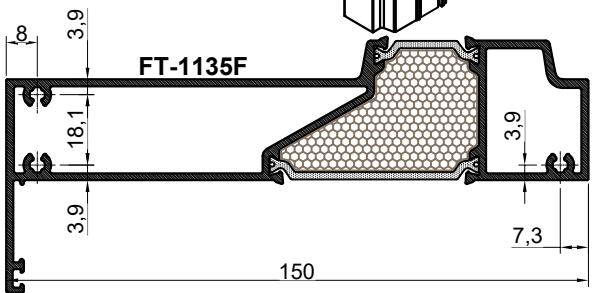
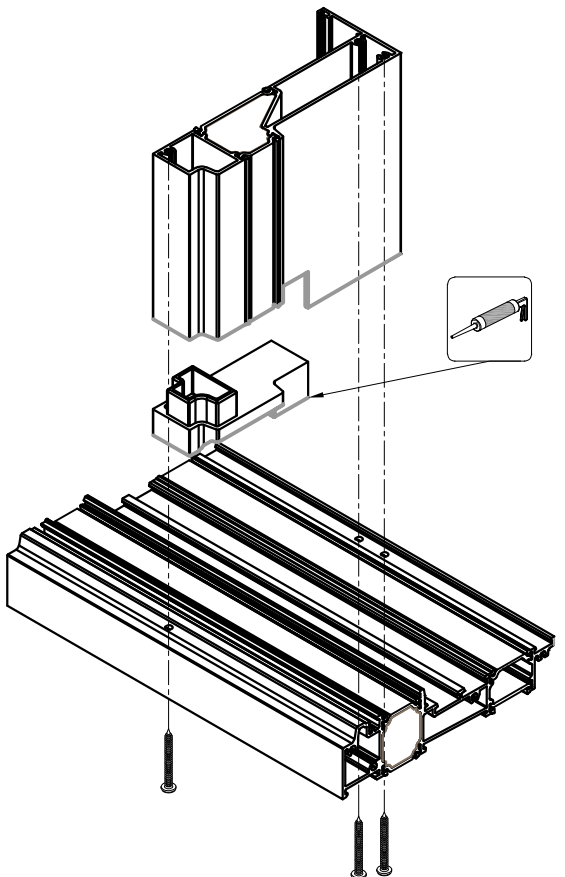
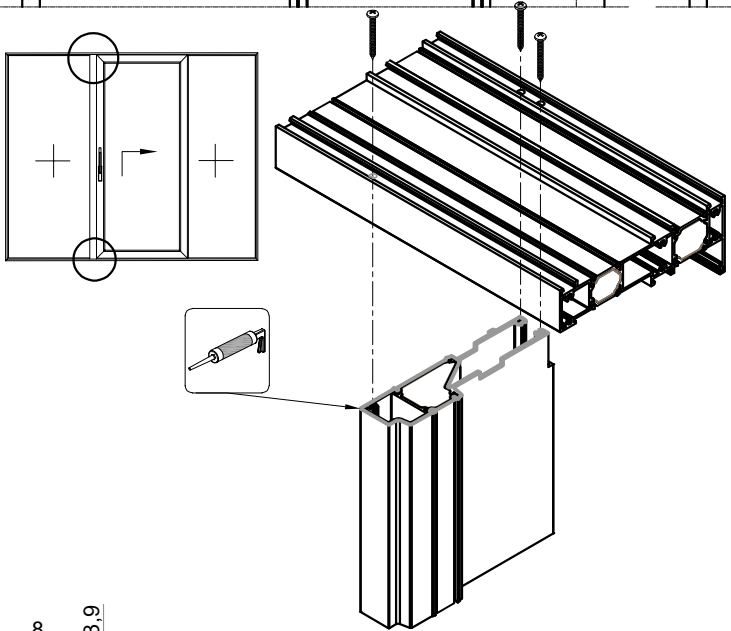
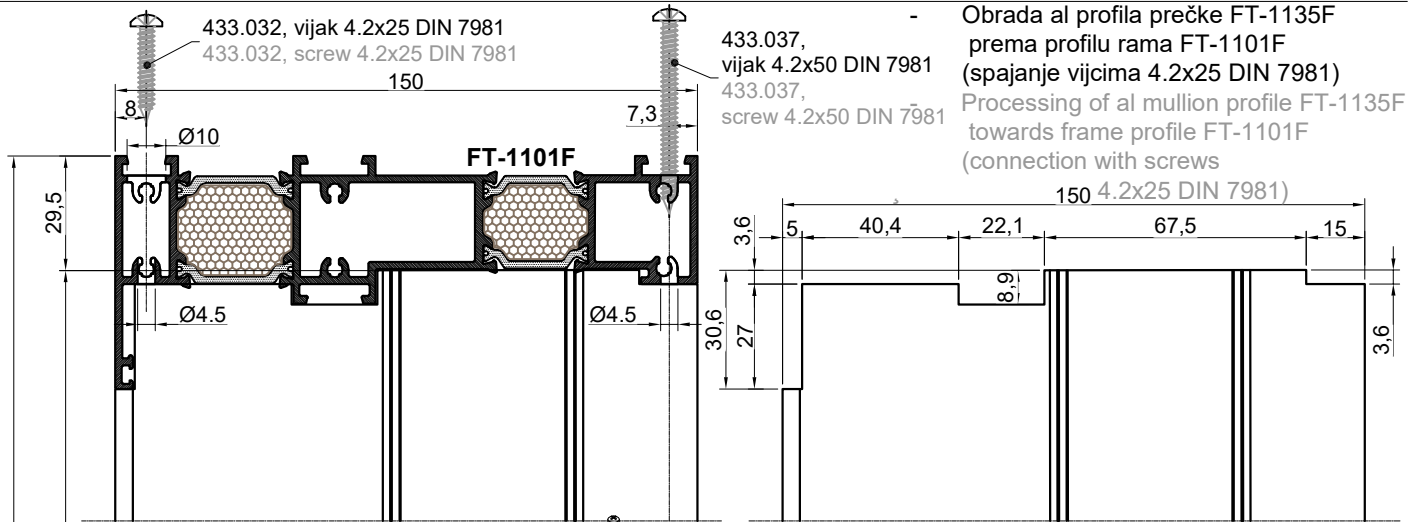

nakon montaže vijka silikonirati otvor  
after montage of the cap, siliconize hole

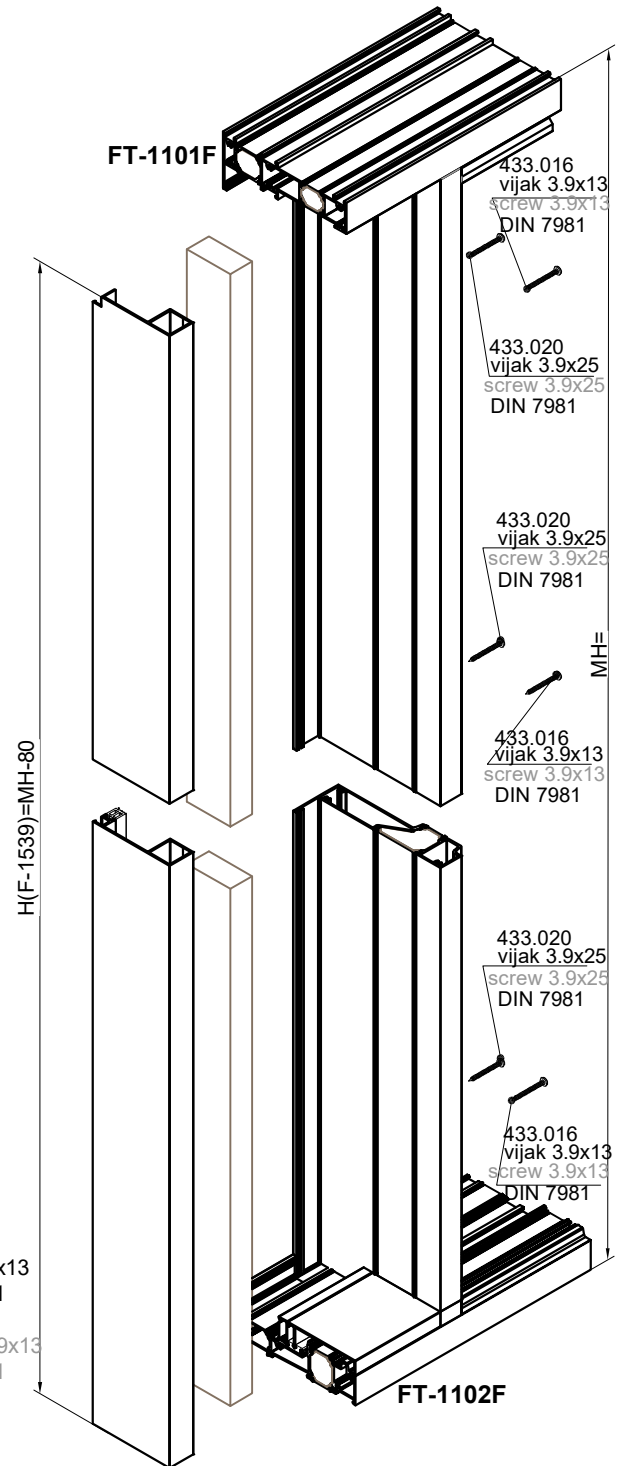
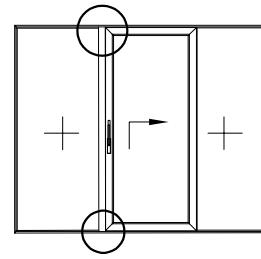
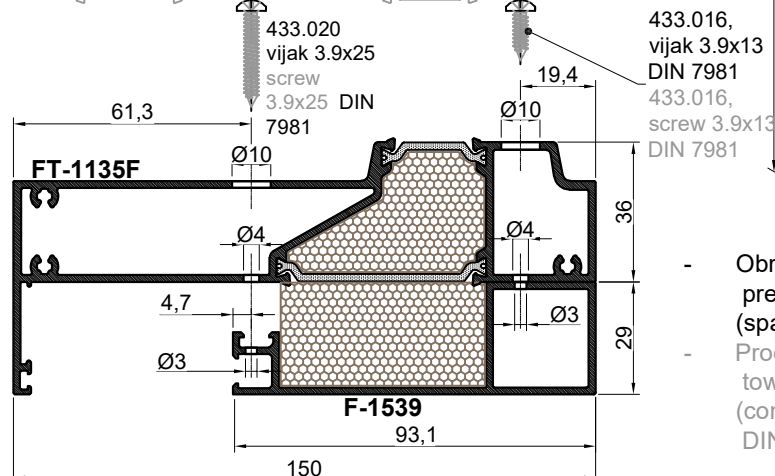
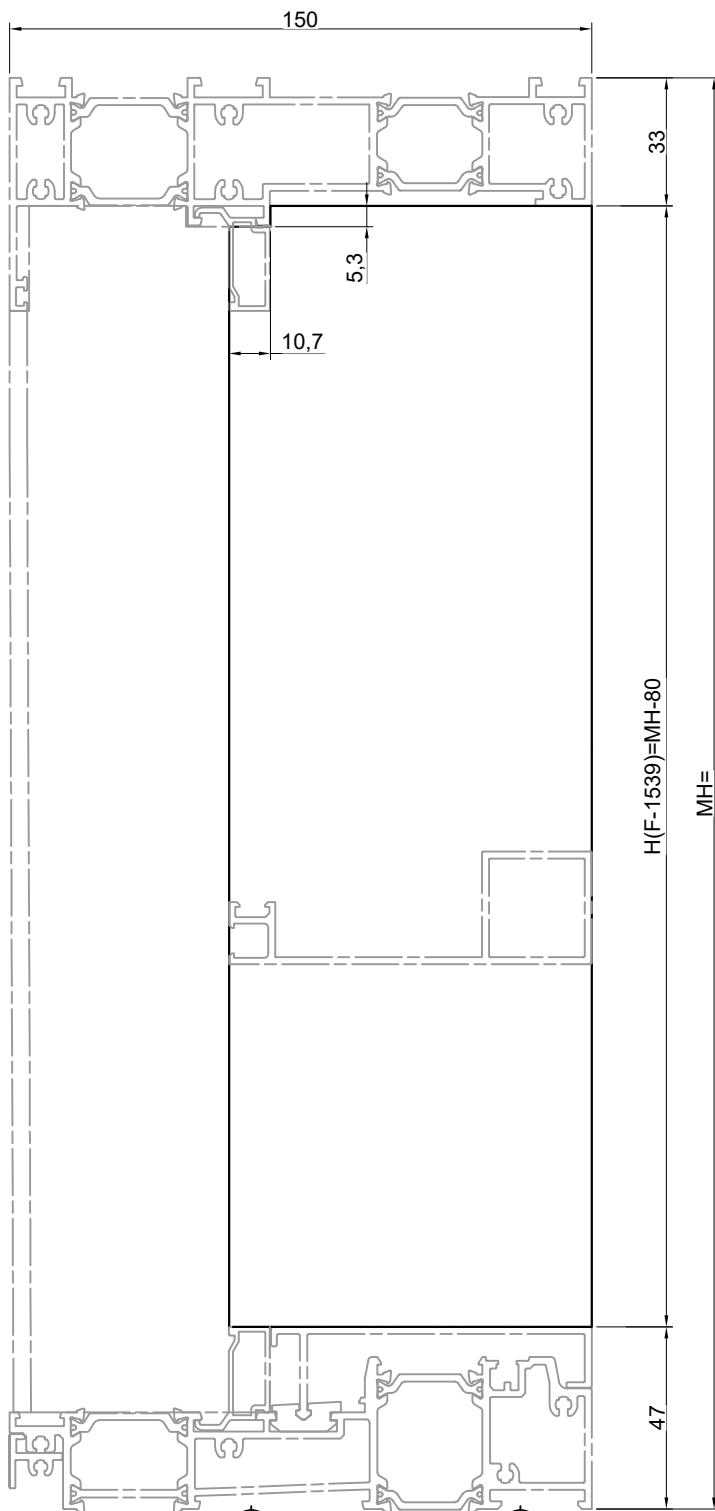

- Obrada al profila F-1539 prema profilu rama FT-1135F (spajanje vijcima 3.9x13 (25) DIN 7981-svako 300 mm)
- Processing of al profile F-1539 towards frame profile FT-1135F (connection with screws 3.9x13 (25) DIN 7981-every 300 mm)

Obrada prečke FT-1136 F prema krilu FT-1120 F  
Processing transom FT-1136 F to the sash FT-1120 F

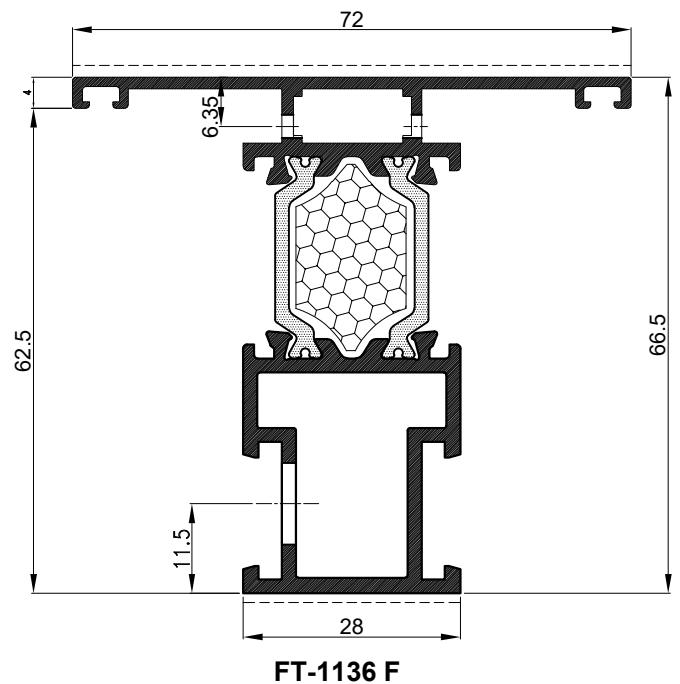
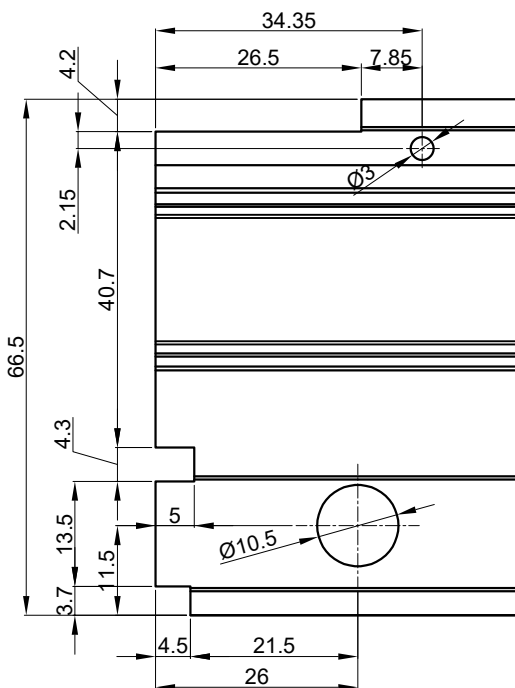
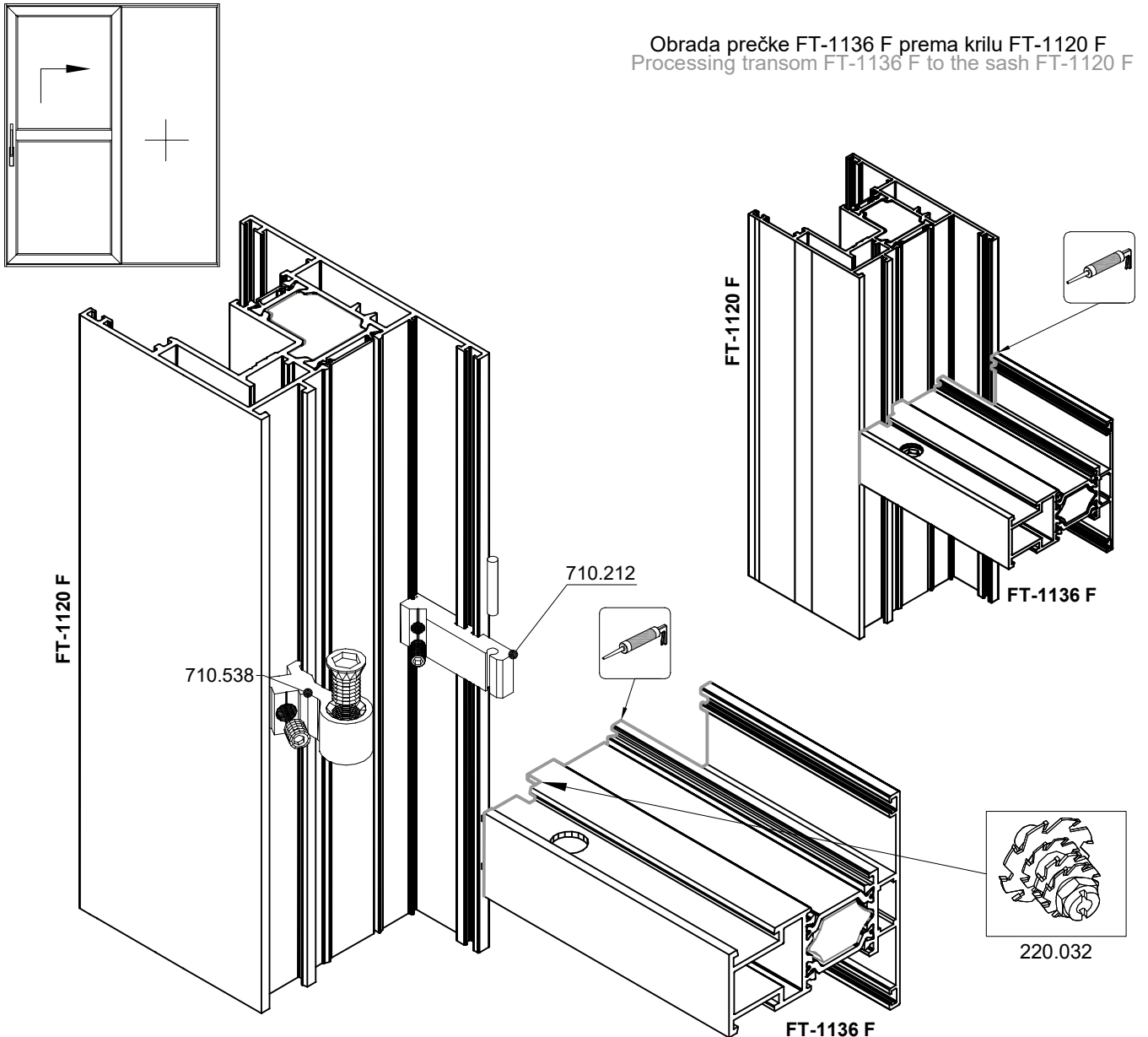

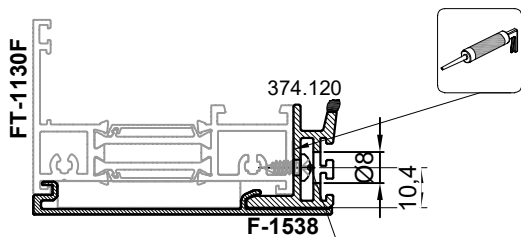

Obrada al. profila **F-1538** i pvc profila **374.120**

(za profil prečke FT-1130F) - **FIKSNI DIO**

- mjera pilanja  $H(F-1538)=MH-63.5$

Processing of al. profile **F-1538** and pvc profile **374.120**

(for mullion profile FT-1130F) - **FIXED PART**

- cutting length  $H(F-1538)=MH-63.5$

433.002, vijak 3.5x9.5 DIN 7981  
(svako max.400 mm)  
433.002, screw 3.5x9.5 DIN 7981  
(every max.400 mm)

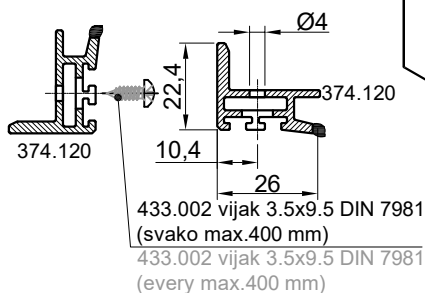
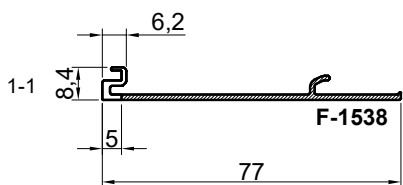
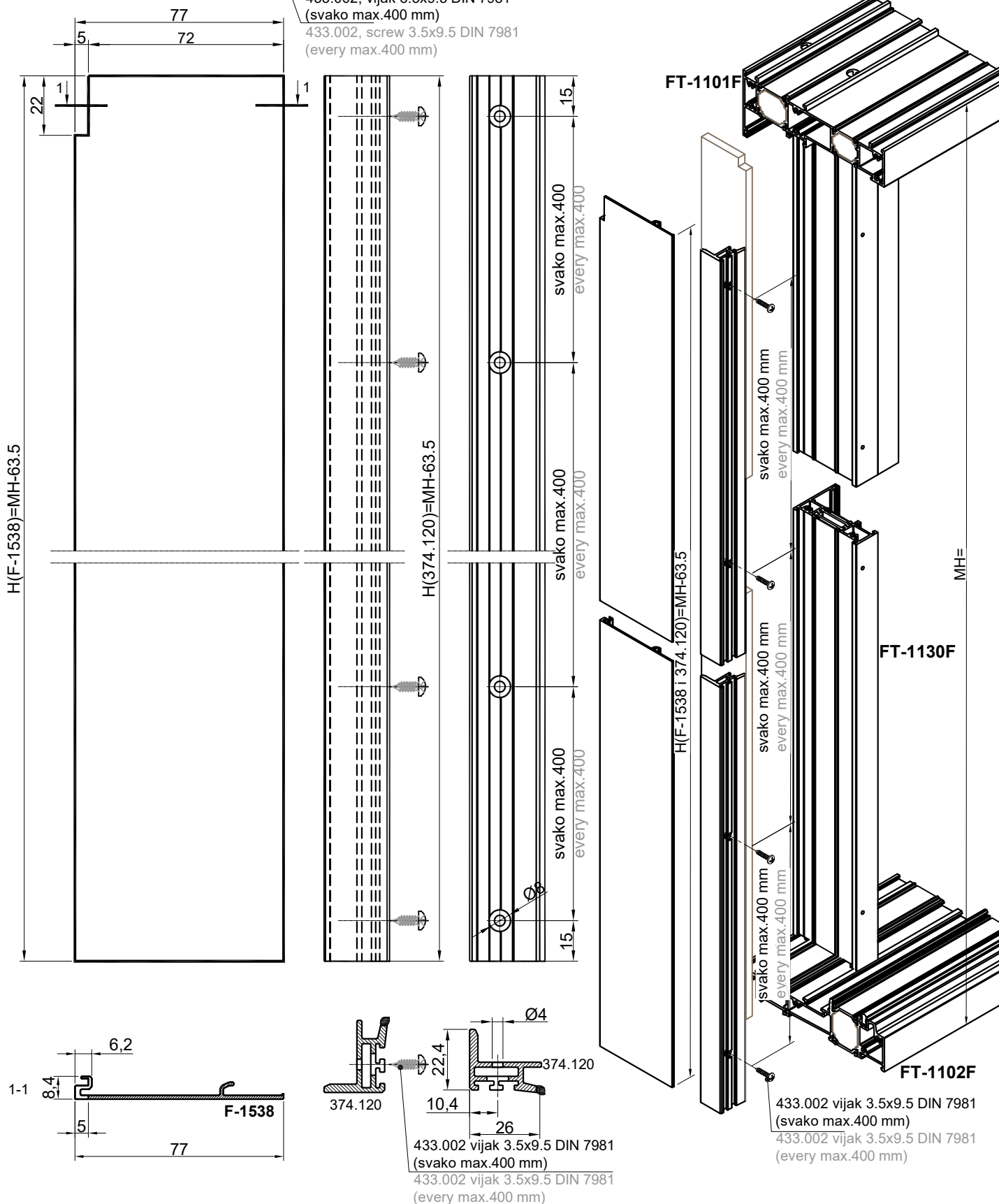

Obrada al. profila **F-1538** i pvc profila **374.083**

(za profil prečke FT-1131F) - **FIKSNI DIO**

- mjera pilanja  $H(F-1538)=MH-63.5$

Processing of al. profile **F-1538** and pvc profile **374.083**

(for mullion profile FT-1131F) - **FIXED PART**

- cutting lenght  $H(F-1538)=MH-63.5$

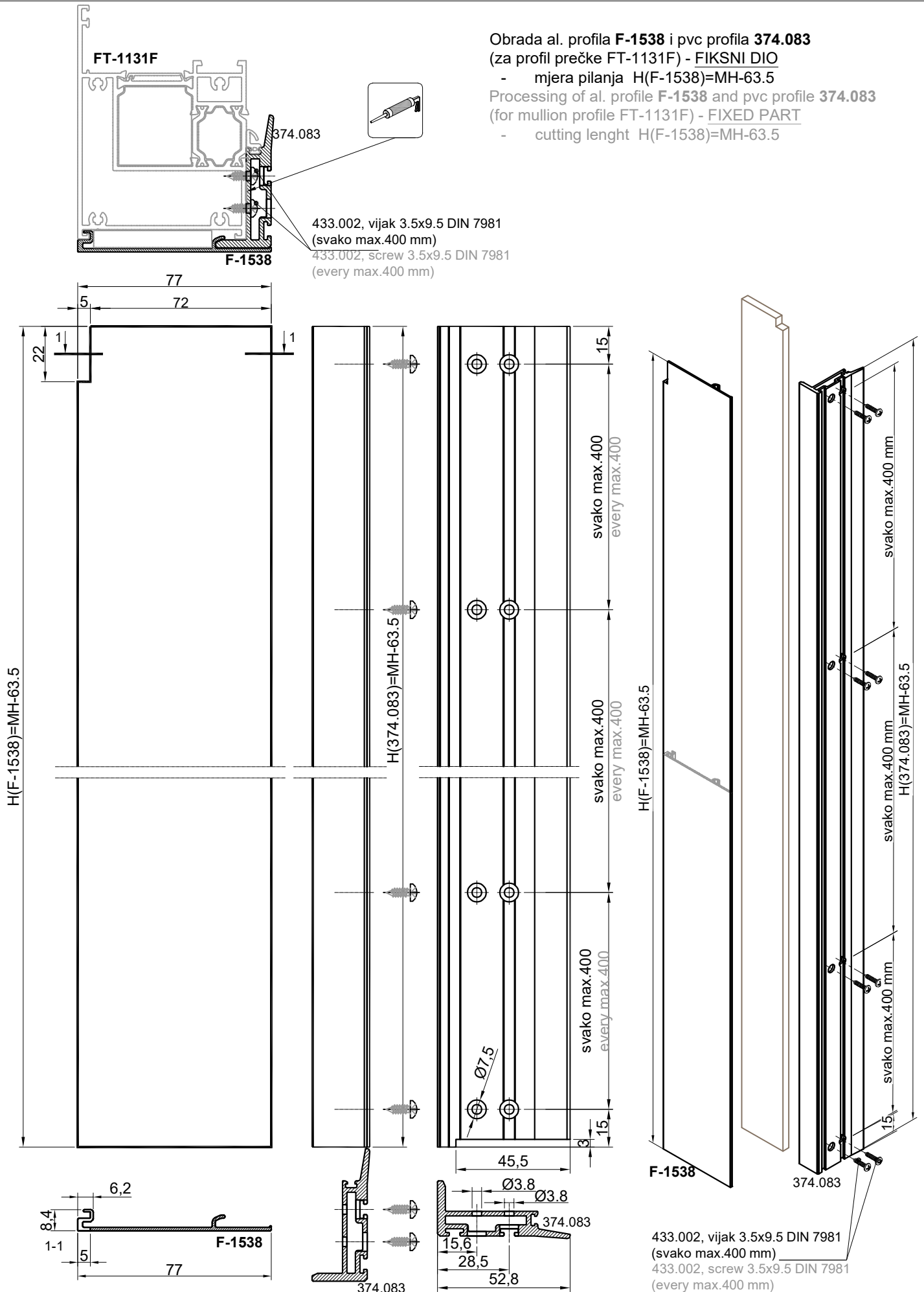

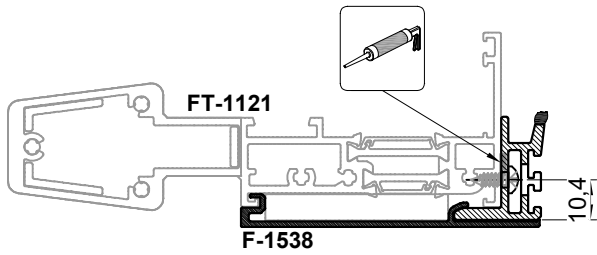

Obrada al. profila **F-1538** i pvc profila **374.120**

- (za profil krila FT-1121) -**KLIZNI DIO**
- mjera pilanja  $H(F-1538)=Hkrila$
  - obrada na glodalici

Processing al. profile **F-1538** and pvc profile **374.120**

(for sash profile FT-1121) -**SLIDING PART**

- cutting lenght  $H(F-1538)=Hsash$
- processing by milling machine

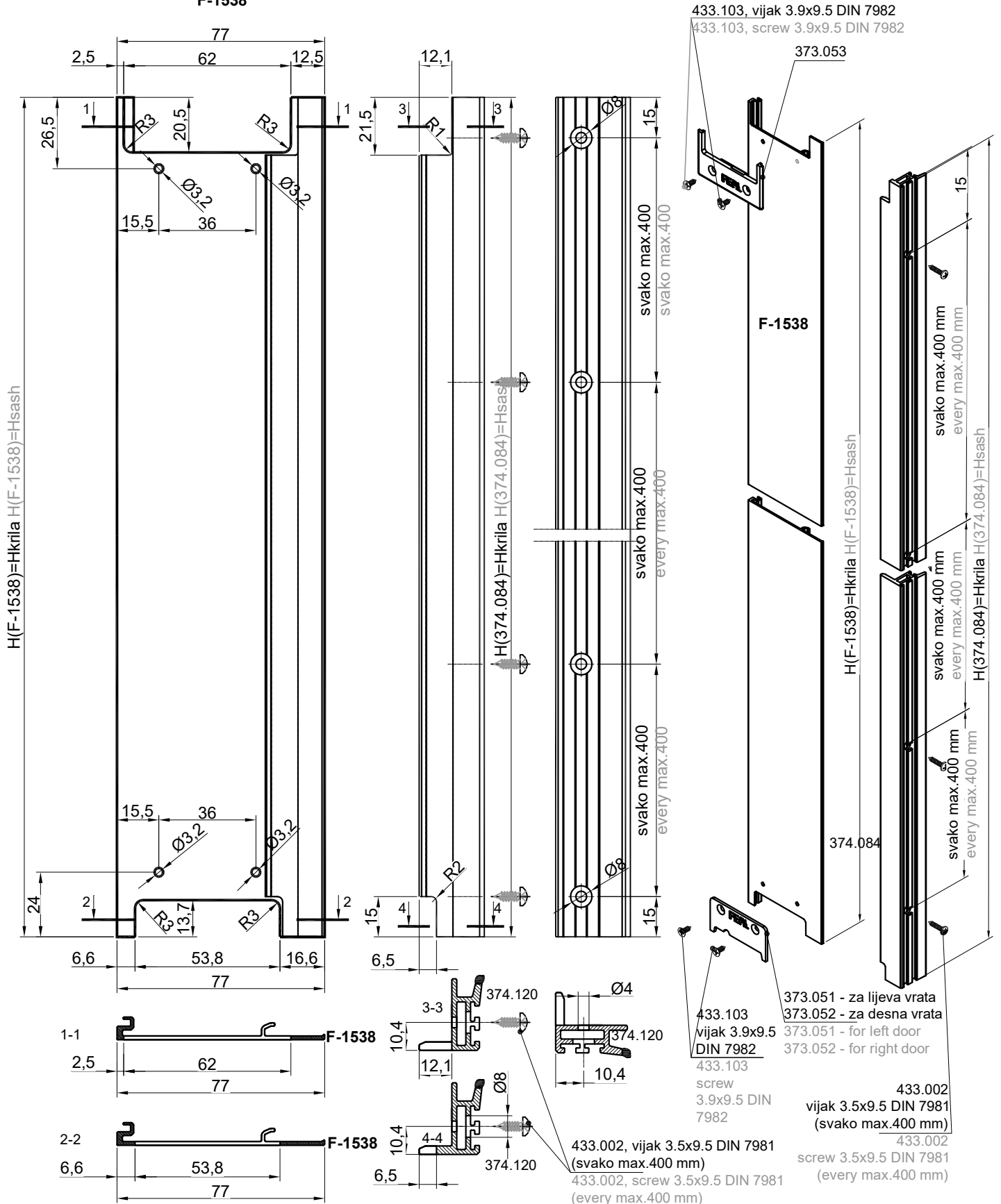



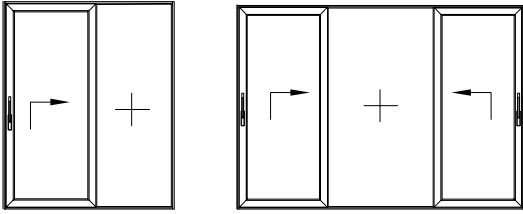

UGRADNJA PROFILA F-1434 NA RAM FT-1100F  
MOUNTING PROFILE F-1434 ON FRAME FT-1100F

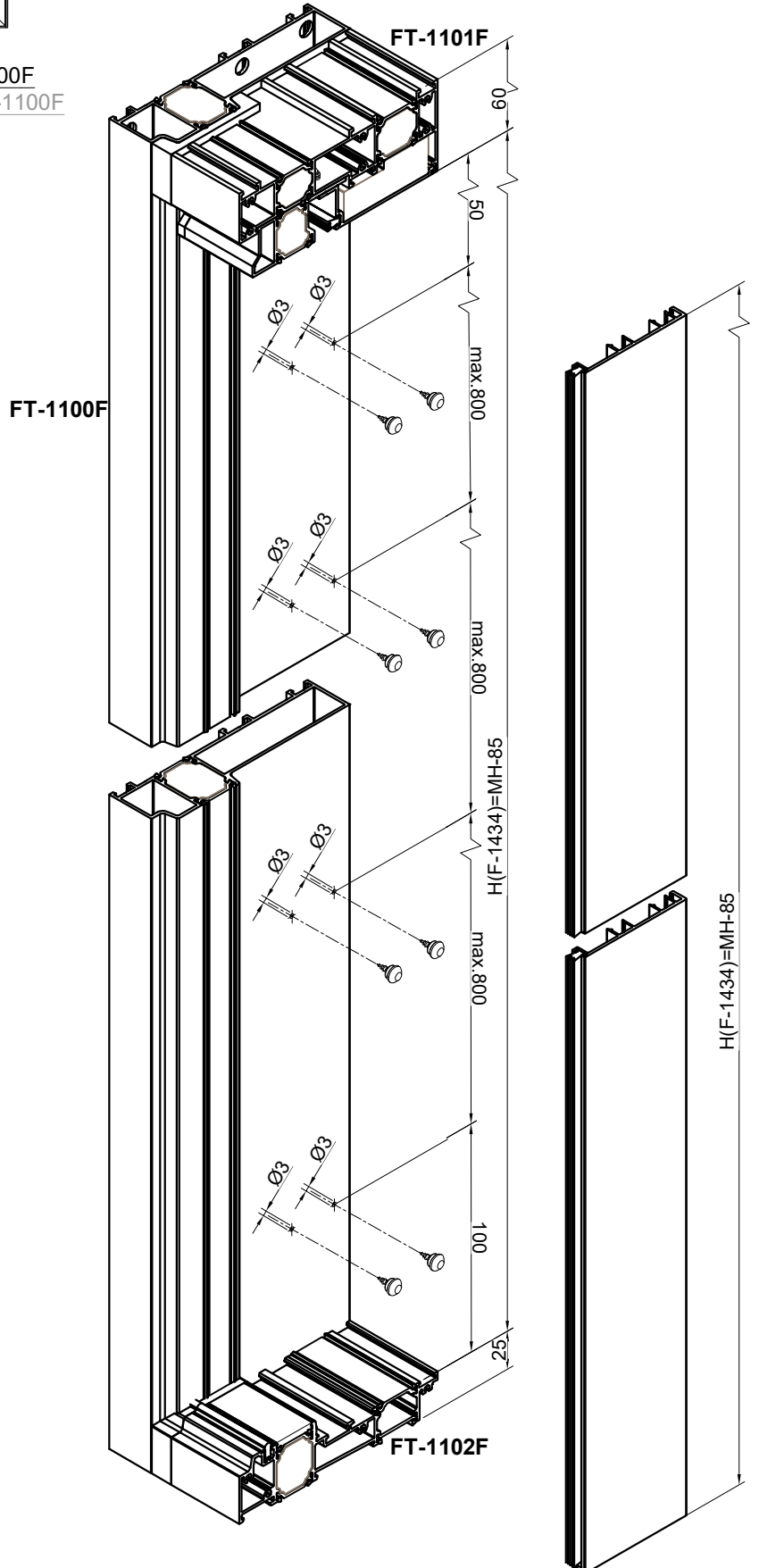
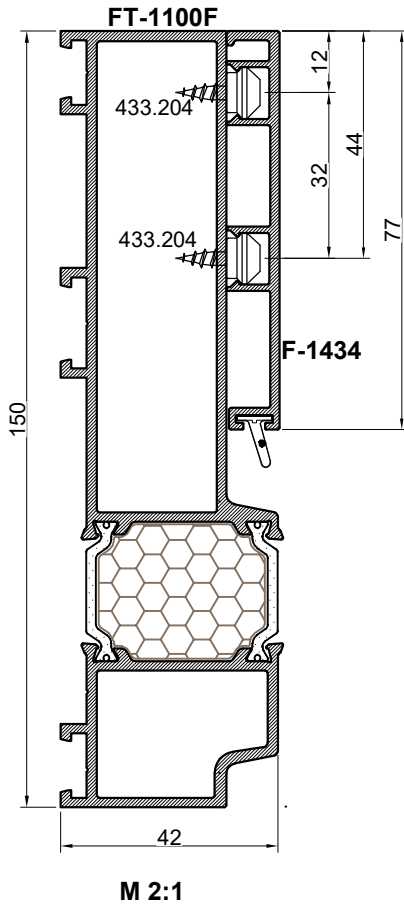

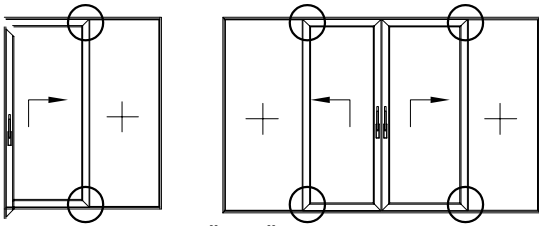

### UGRADNJA UBLAŽIVAČA UDARA KRILA 345.010

-koristi se kod jednokrlnog i dvokrlnog  
podizno-kliznog s fiksnim dijelom  
-ugrađuje se na krilo, simetrično gore i dolje  
**SASH BUMPER MOUNTAGE 345.010**

-is used at single and double lift and slide sash with  
fixed part  
-it is mounted on the sash, symmetrical up and down

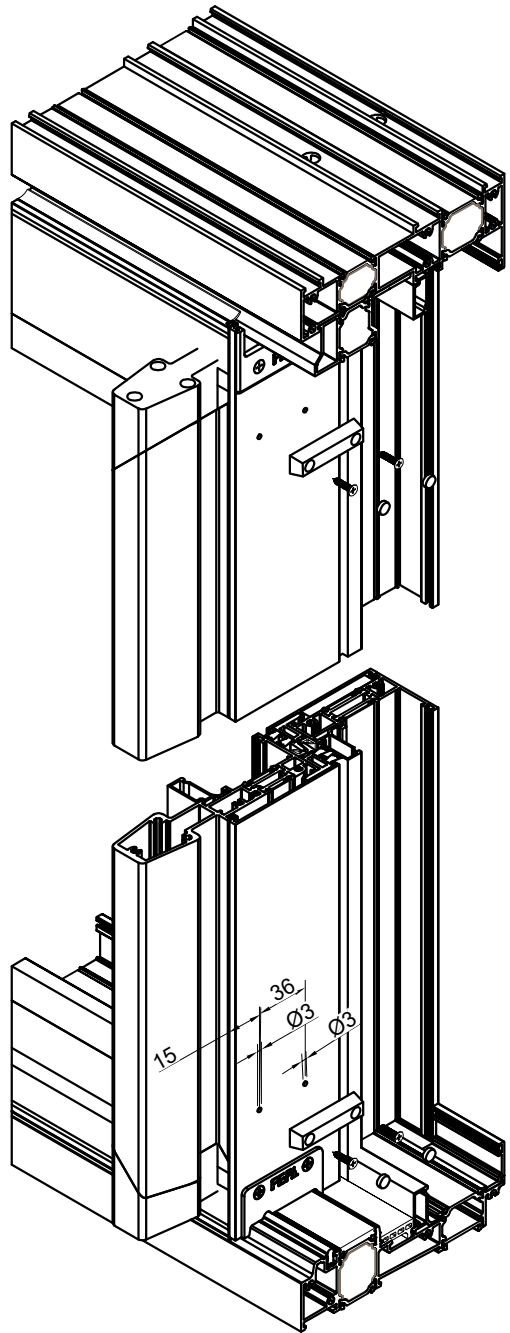
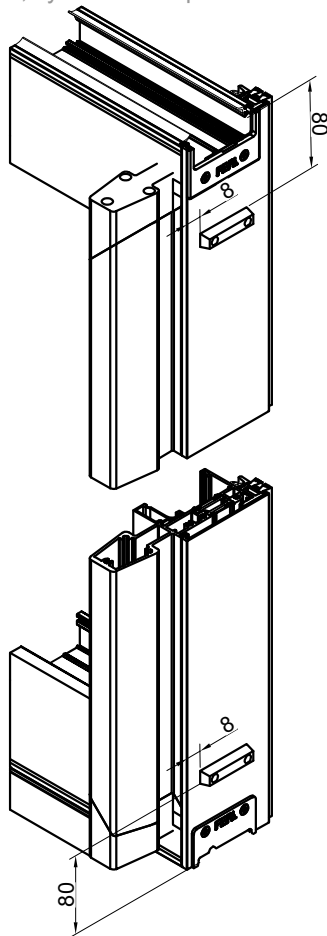

### Obrada profila F-1538 Processing profile F-1538

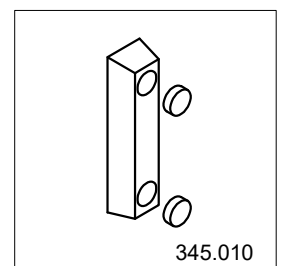
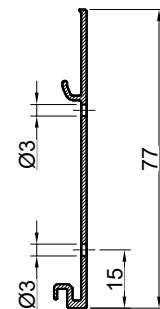
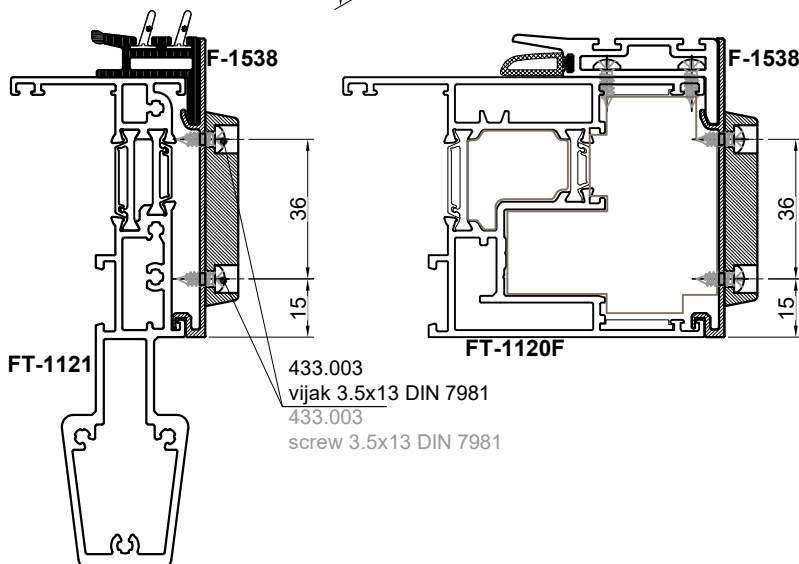

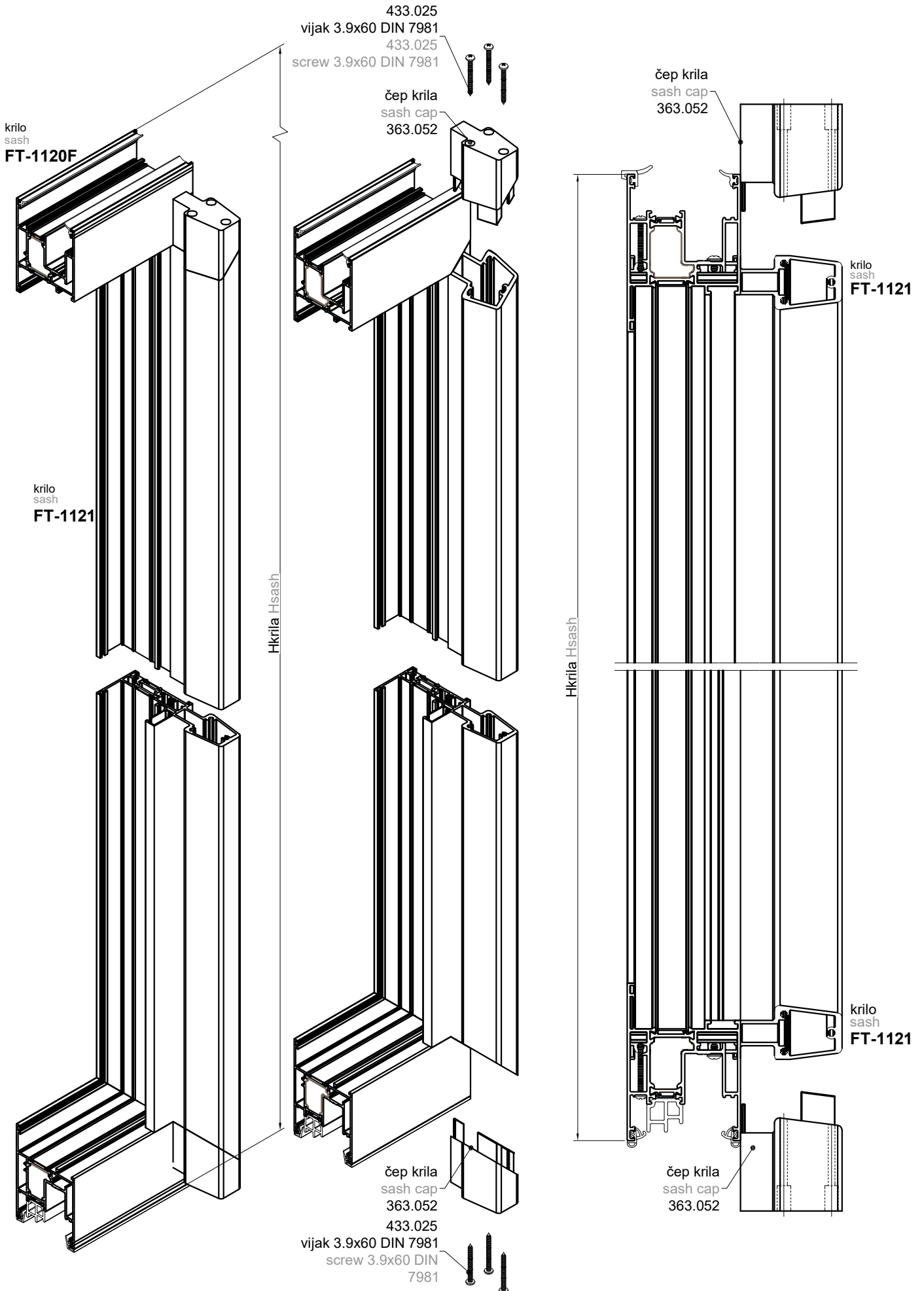

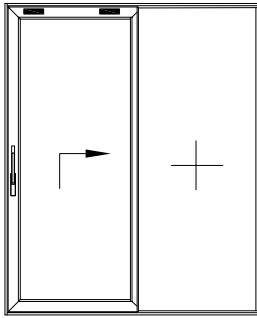

UGRADNJA USMJERIVAČA KRILA 373.078  
(4 kom. po krilu)  
SASH GUIDE MOUNTING 373.078  
(4 pcs. per sash)

usmjerivač krila  
sash guide  
373.078

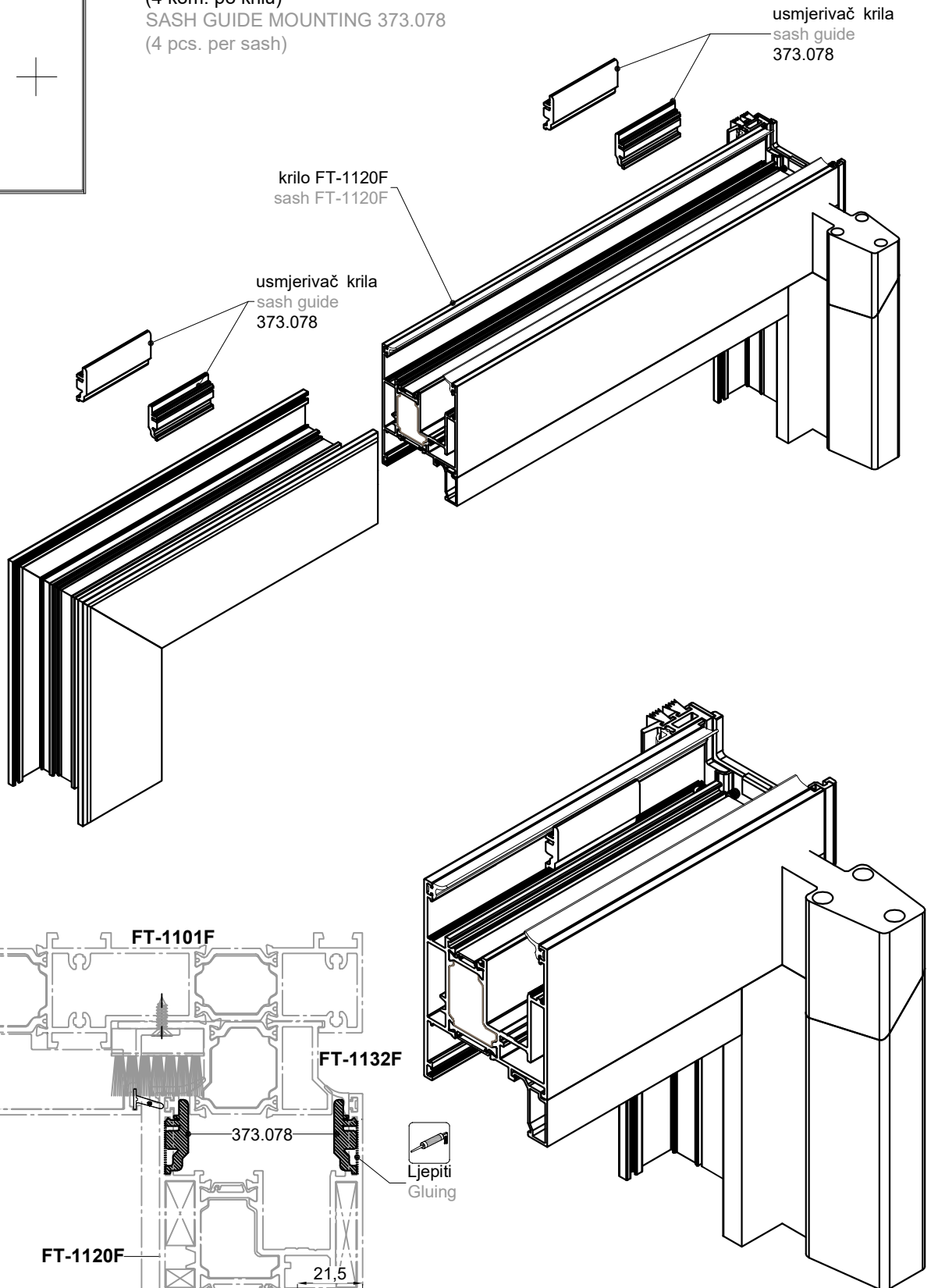

### UGRADNJA MASKE PRAGA F-1536 MOUNTING TRESHOLD MASK F-1536

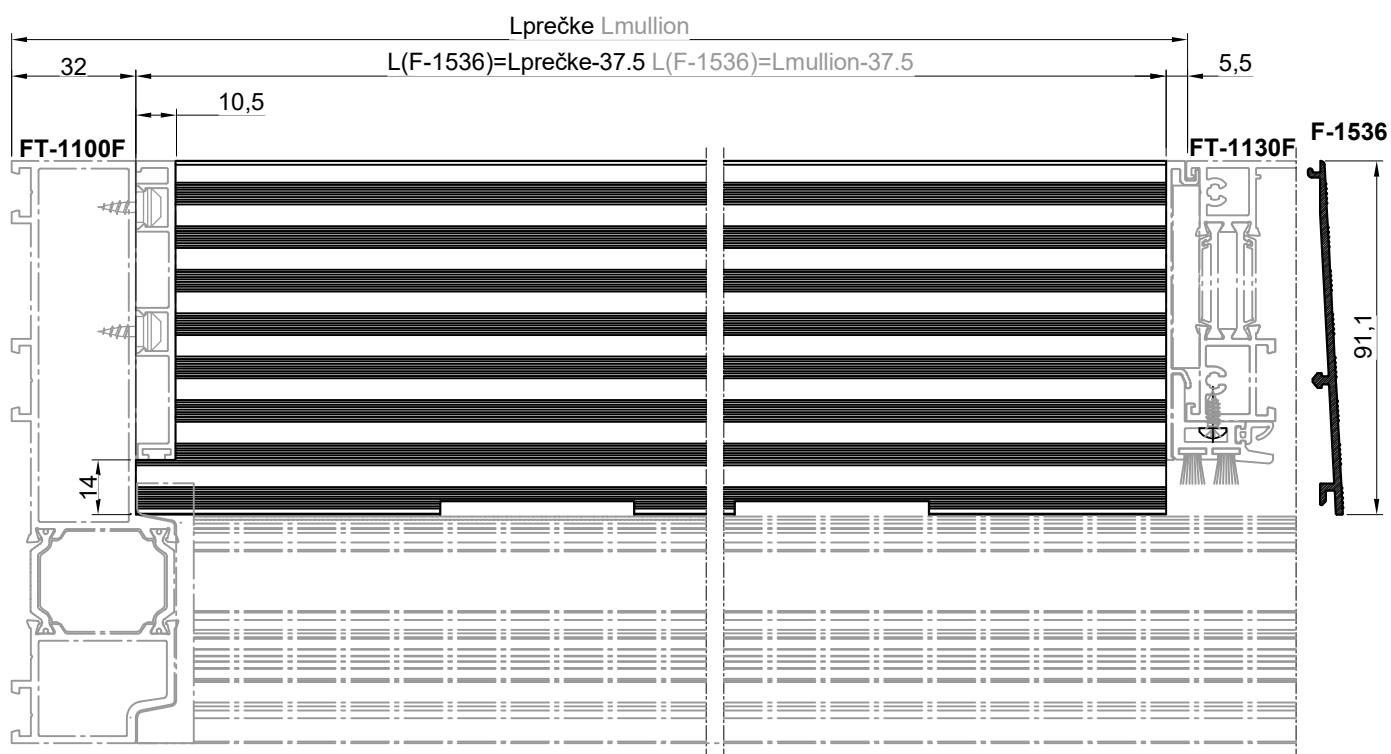
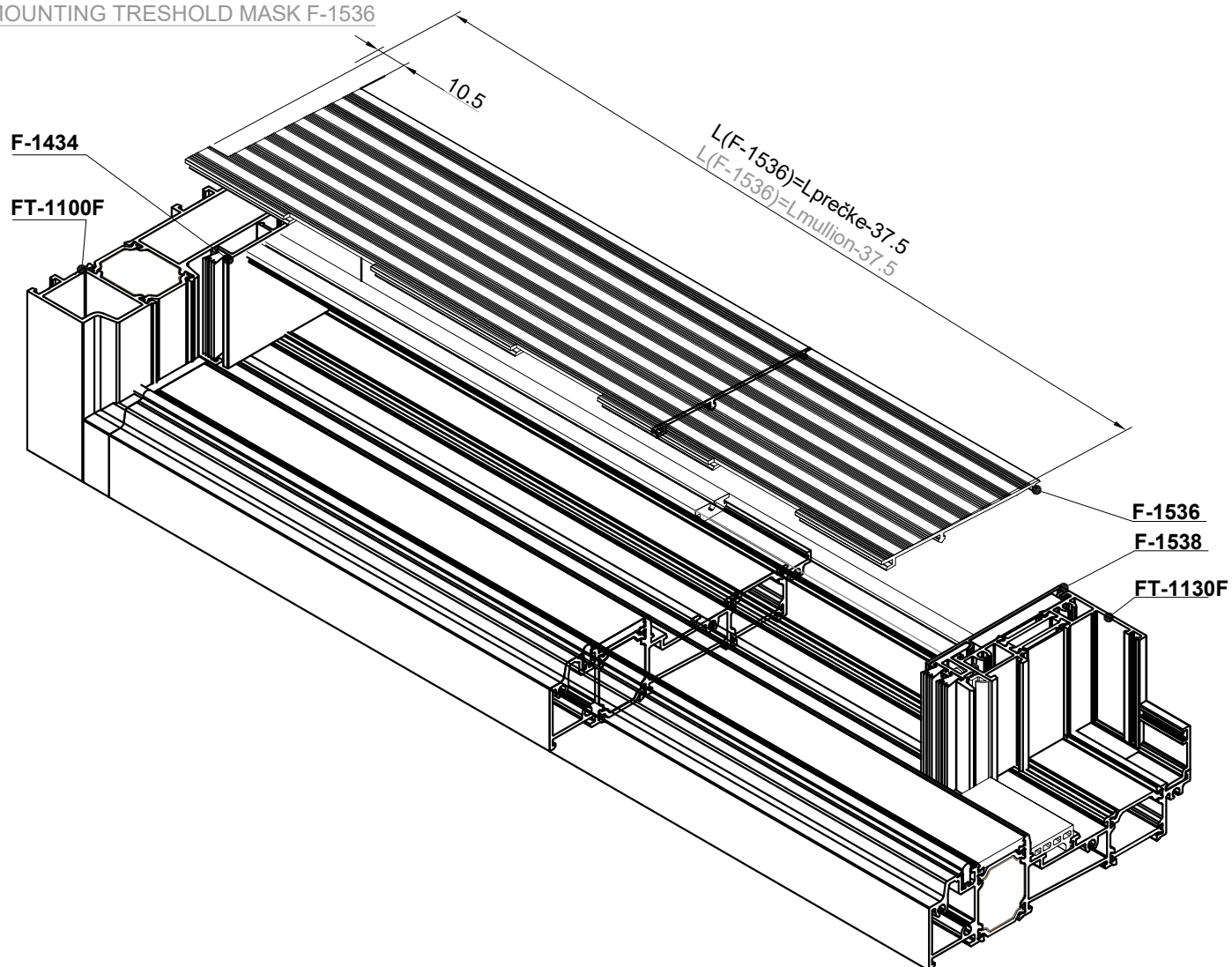





UGRADNJA I OBRADA AL.PROFILA FT-1030F S ČEPOM  
MOUNTING AND PROCESSING AL.PROFILE FT-1030F WITH CAP

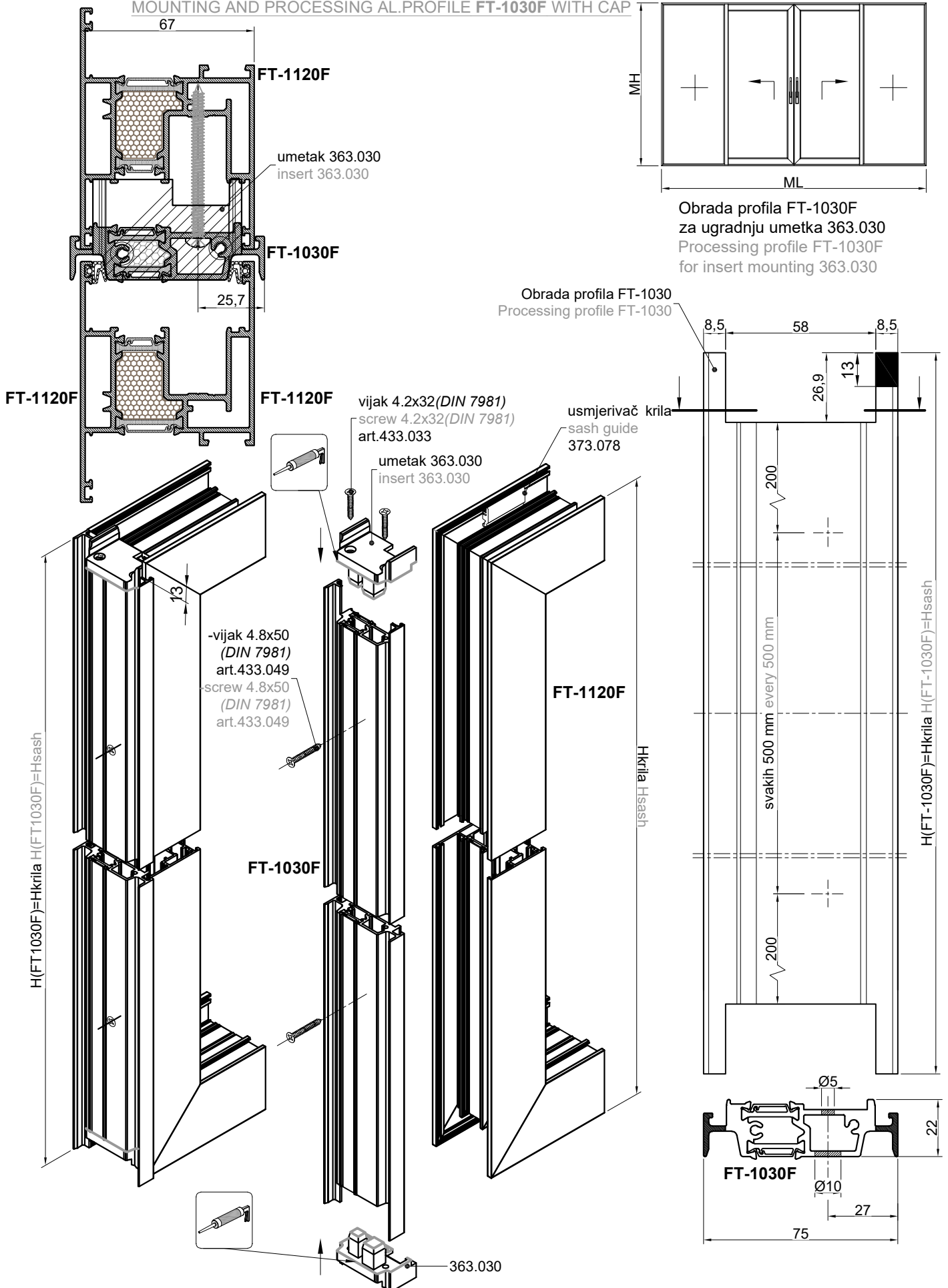

### UGRADNJA I OBRADA AL.PROFILA FT-1030F S ČEPOM KAD IMAMO USPORIVAČ KRILA ATRIUM COMFORT CLOSE MOUNTING AND PROCESSING AL.PROFILE FT-1030F WITH CAP FOR SASH RETARDER ATRIUM COMFORT CLOSE

Obrada profila FT-1030F za ugradnju:

- umetka 363.075 u gornjoj zoni (za lijevo krilo) - ATRIUM COMFORT CLOSE
- umetka 363.076 u gornjoj zoni (za desno krilo) - ATRIUM COMFORT CLOSE
- umetka 363.030 u donjoj zoni

Processing profile FT-1030F for mounting:

- insert 363.075 at top (left sash) - ATRIUM COMFORT CLOSE
- insert 363.076 at top (right sash) - ATRIUM COMFORT CLOSE
- insert 363.030 at bottom

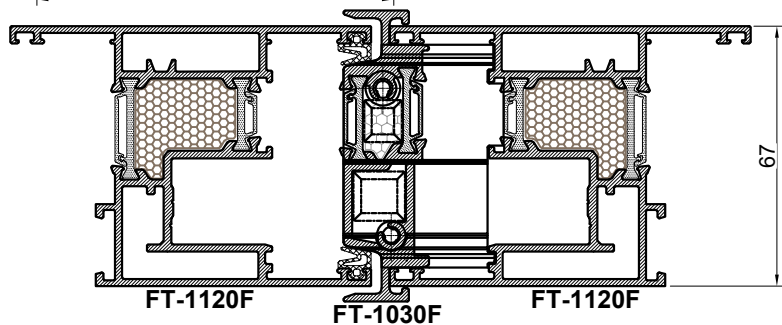
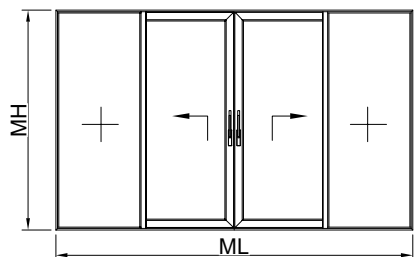

Vijak 4.2x32 (DIN 7981)  
screw 4.2x32 (DIN 7981)  
art.433.033

usmjerivač krila 373.078  
sash guide 373.078

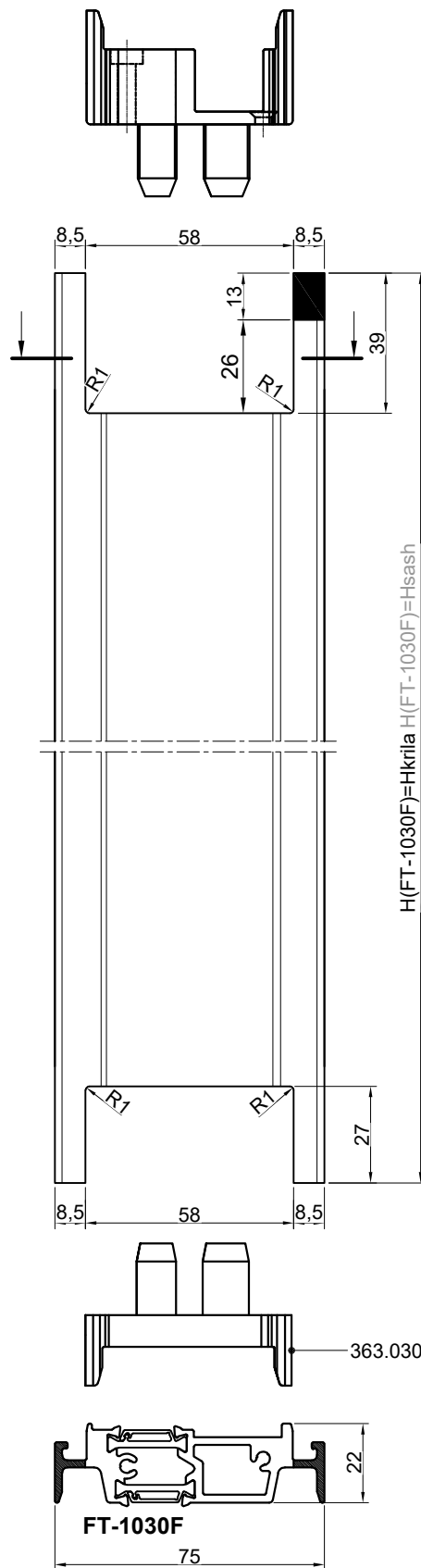
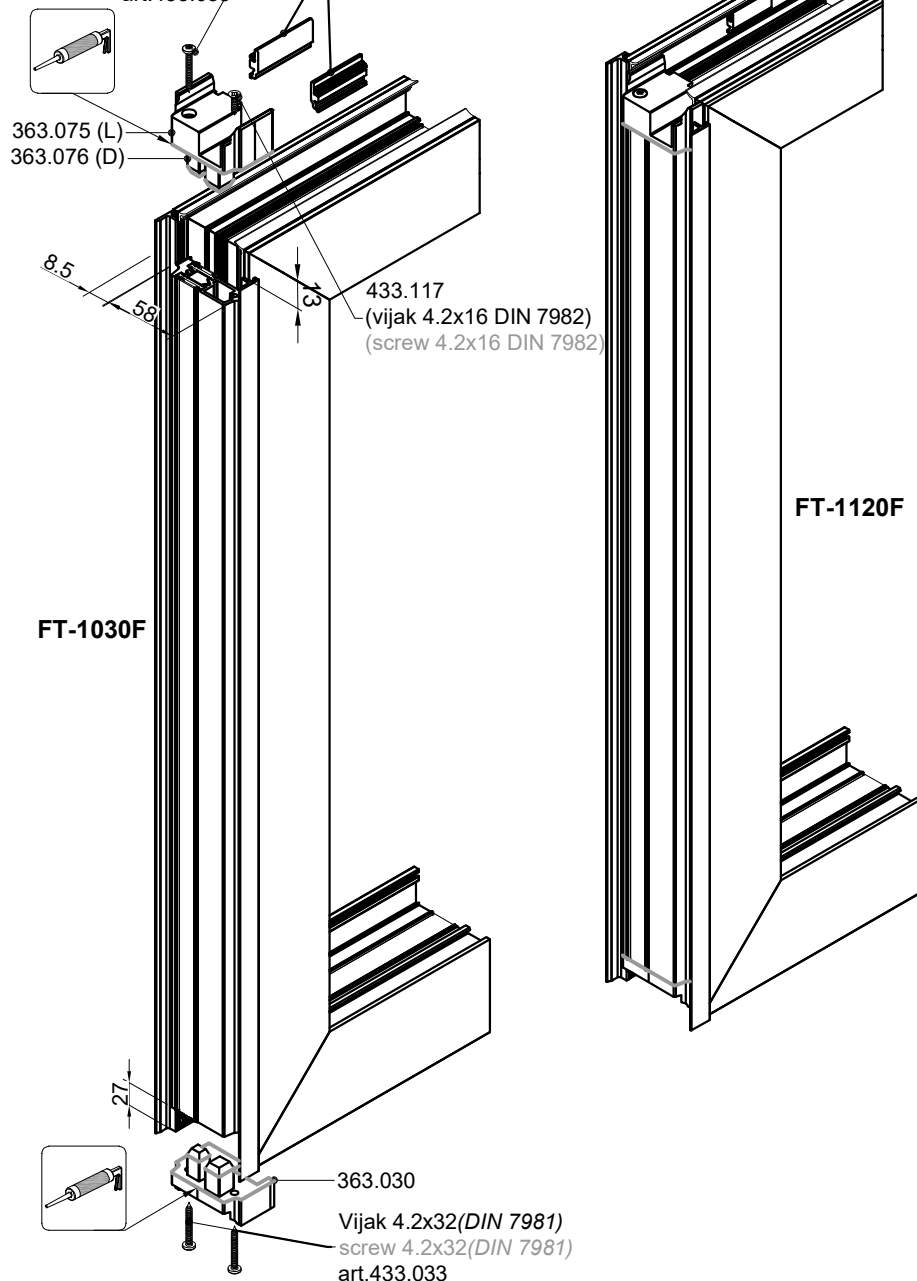

### PRIČVRŠĆIVANJE PROFILA FT-1030F ZA KRILO FT-1120F

(KROZ ZAPINJAČE NA RAMU)  
CONNECTING AL.PROFILE FT-1030F  
FOR SASH FT-1120F  
(THROUGH LOCKING BOLT)

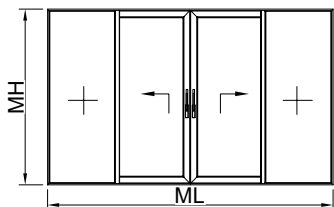

brava podizno kliznog  
mehanizma (h=2400 mm)  
espag (h=2400 mm)

Vijak 4.8x60(DIN 7981)  
screw 4.8x60(DIN 7981)  
art.433.050

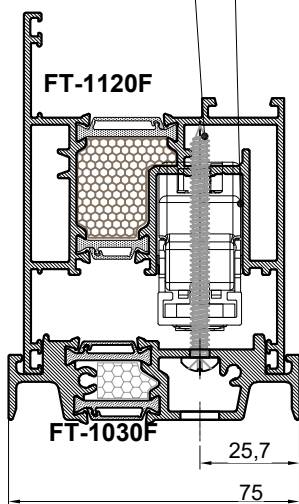

zapinjač na ramu  
locking bolt

433.129  
(vijak 4.8x16 DIN7982)  
433.129  
(screw 4.8x16 DIN7982)

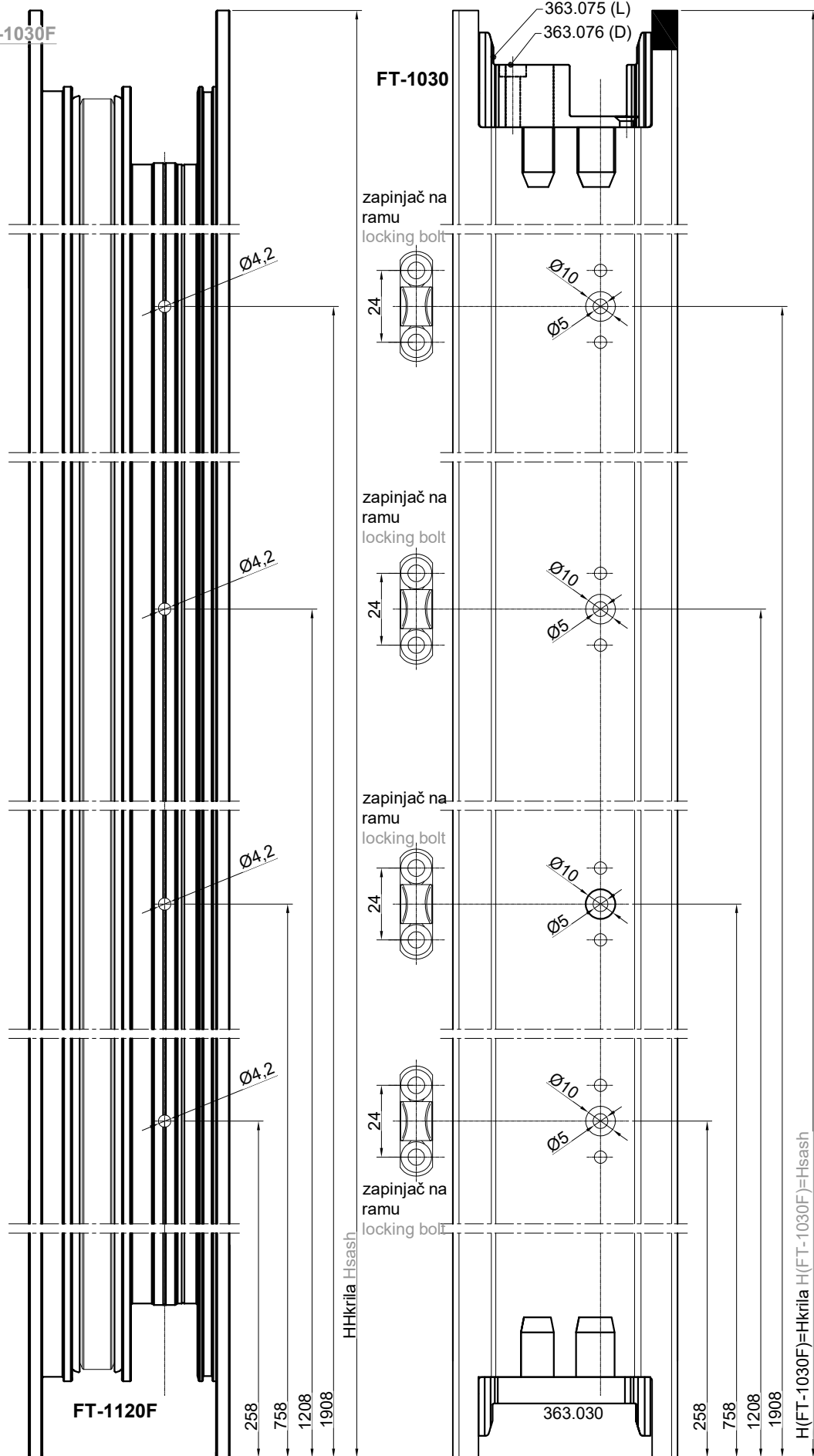

### UGRADNJA MASKE F-1542 I BRTVE 344.080 MOUNTING MASK F-1542 AND GASKET 344.080

Lprečke1 Lmullion1

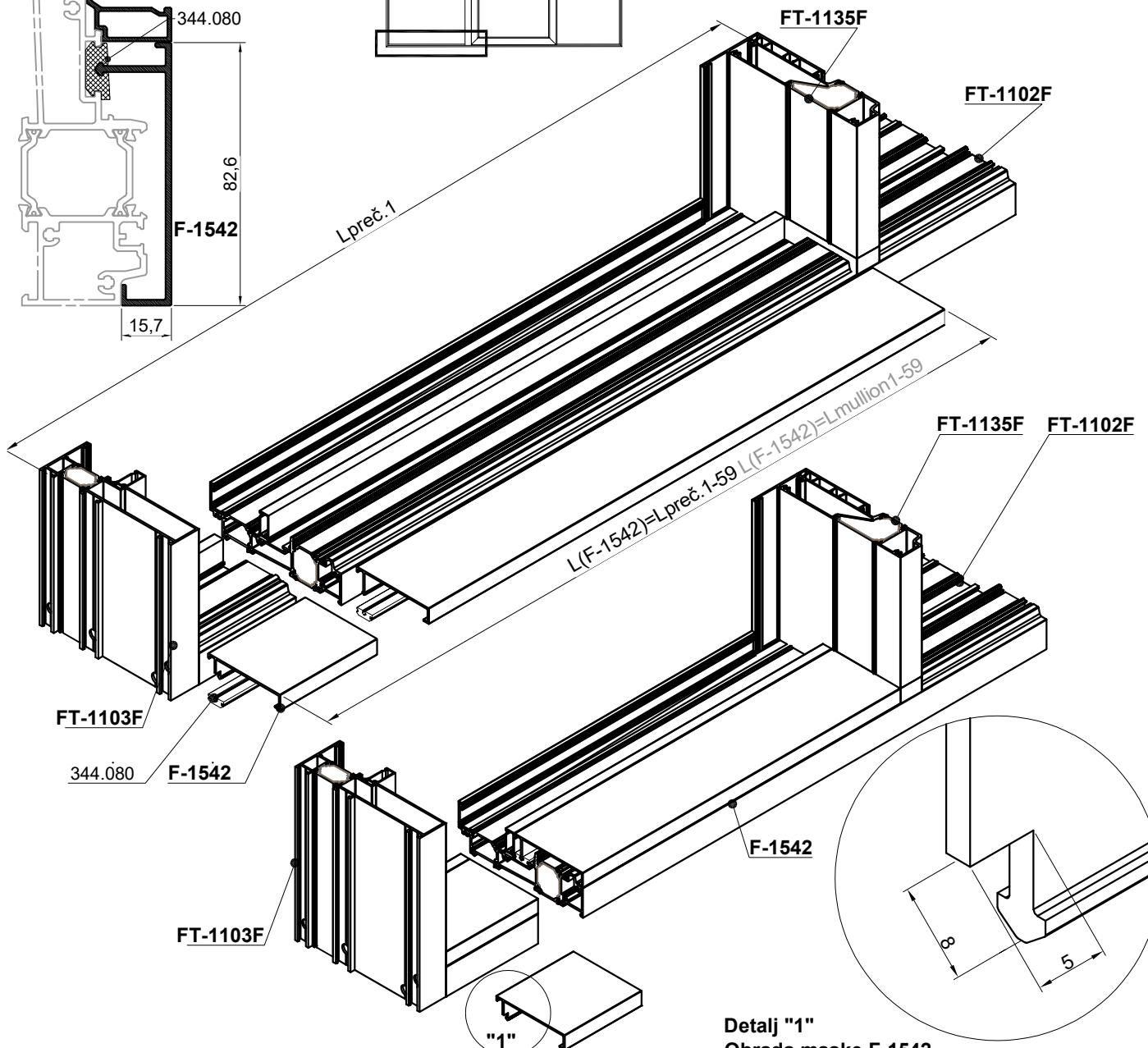
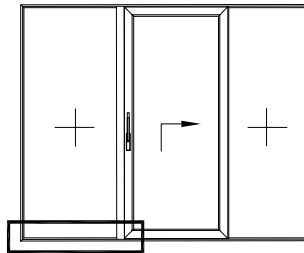
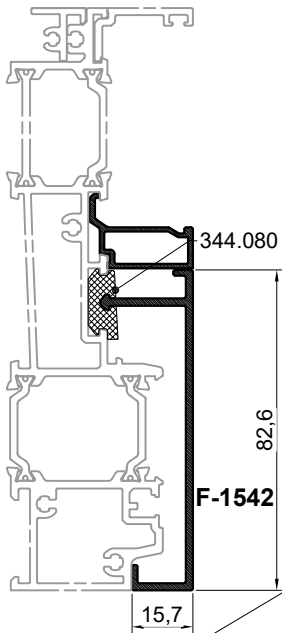
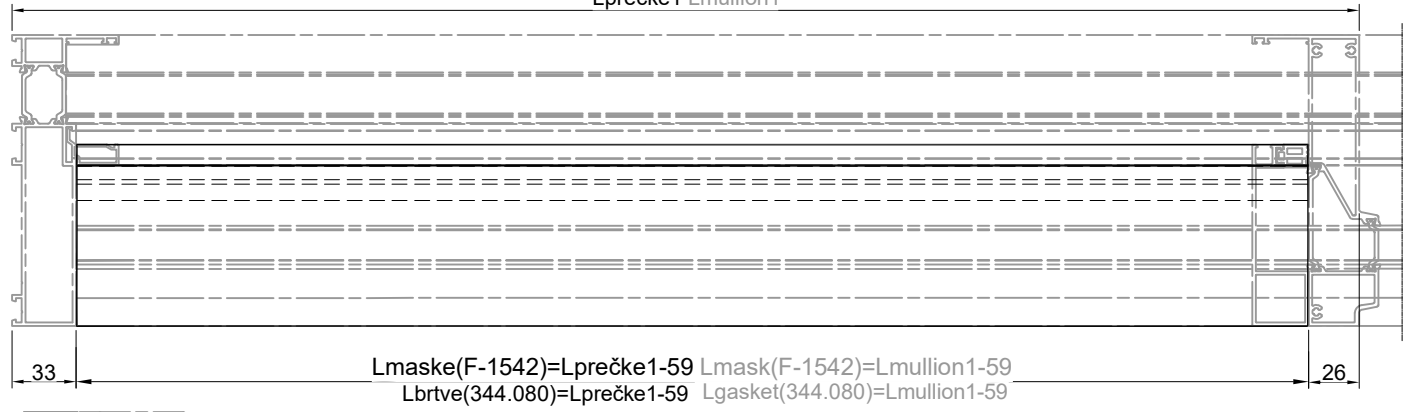

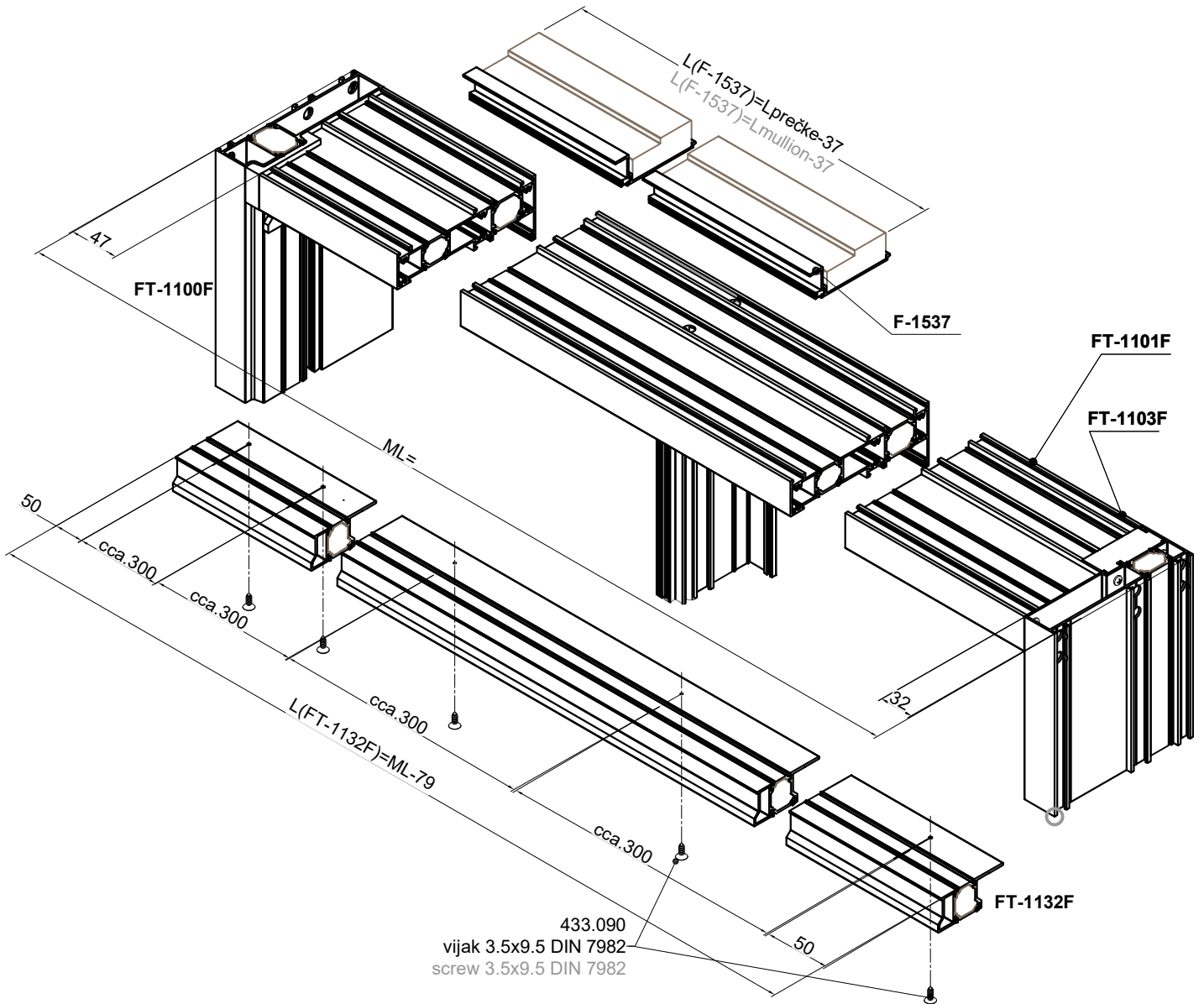

**M 1.5:1**  
presjek kroz otvarajući dio  
cross section through opening part

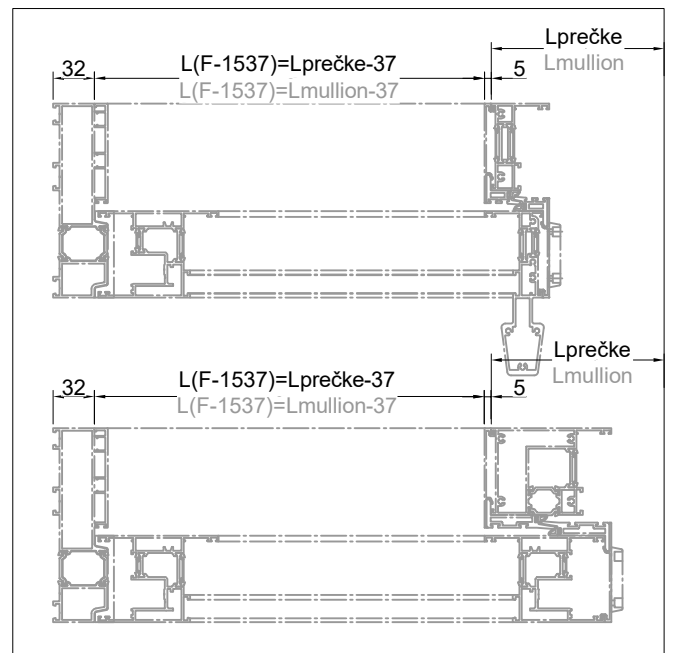
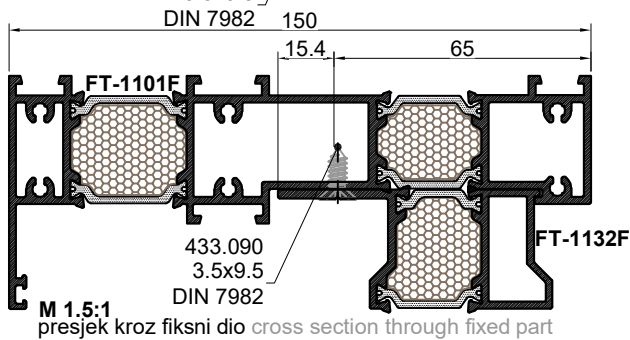
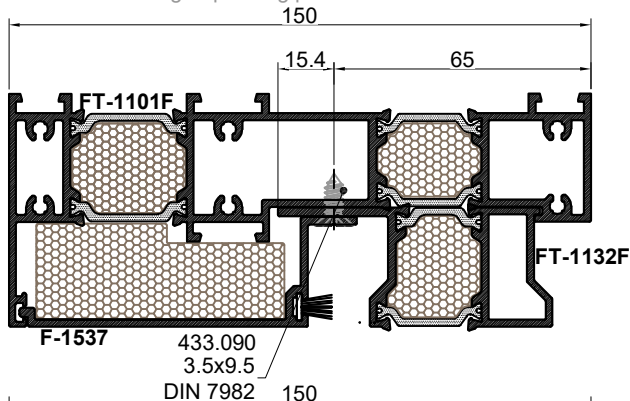

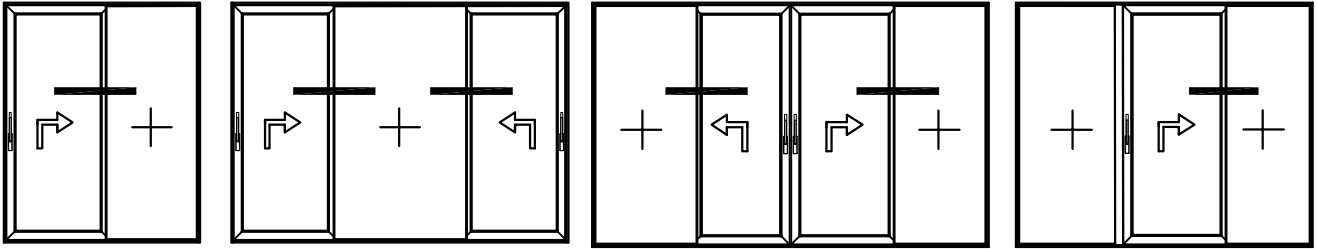

- Ljepljenje stakla za krilo FT-1120
- Gluing glass on sash FT-1120

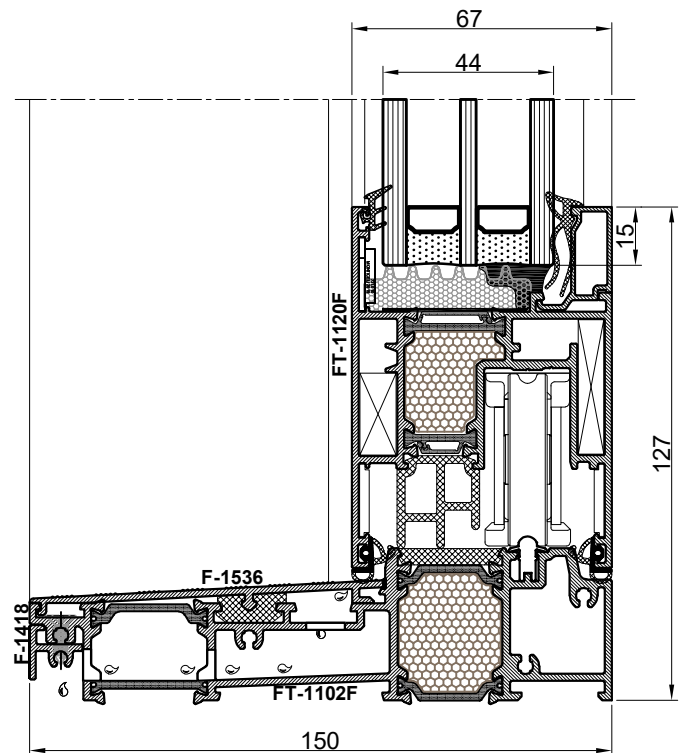
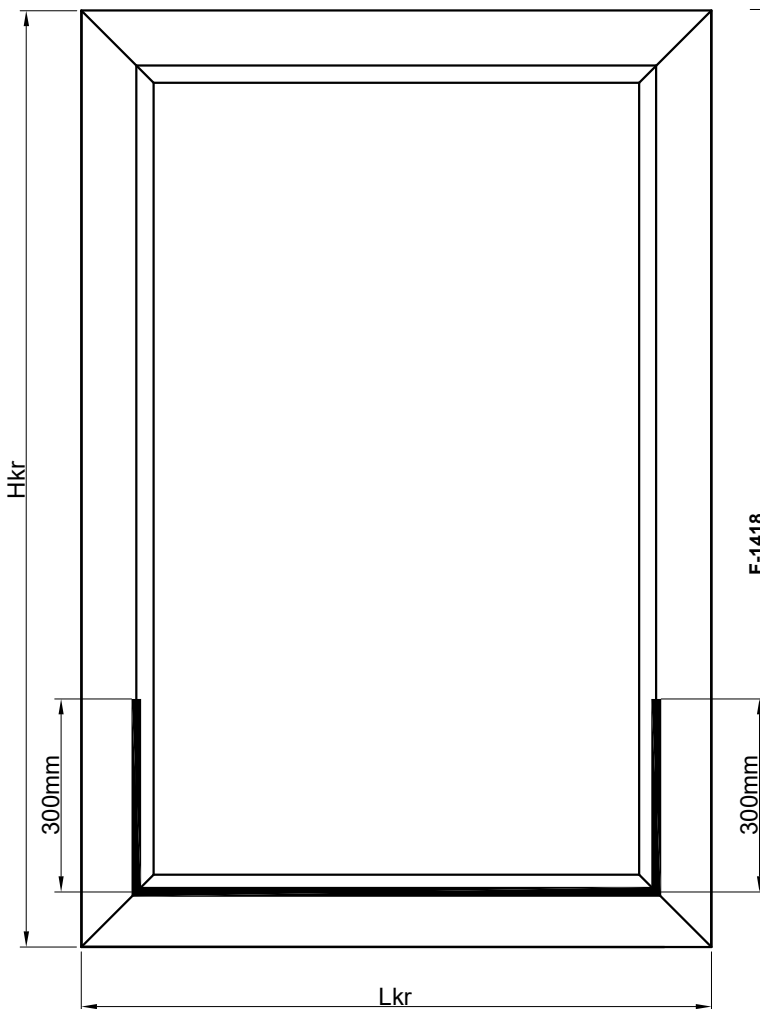

### LIJEPLJENJE TERMO ISPUNE XPE ZA PODLOGU

U uvjetima veće izloženosti prozora padalinama, radi mogućeg prodora kapljevina, preporučuje se lijepljenje termo ispune XPE za podlogu, neutralnim ljepilom / npr. "Henkel" - Teroson MS 939 /, prema crtežu.

### GLUEING OF THE THERMO INSULATION XPE

In conditions of larger rain percipitation, to preventing possible rain water breach, it is recommended to glue thermo insulation XPE to the profile with neutral glue / e.g. "Henkel" - Teroson MS 939 /, as shown to the drawing.

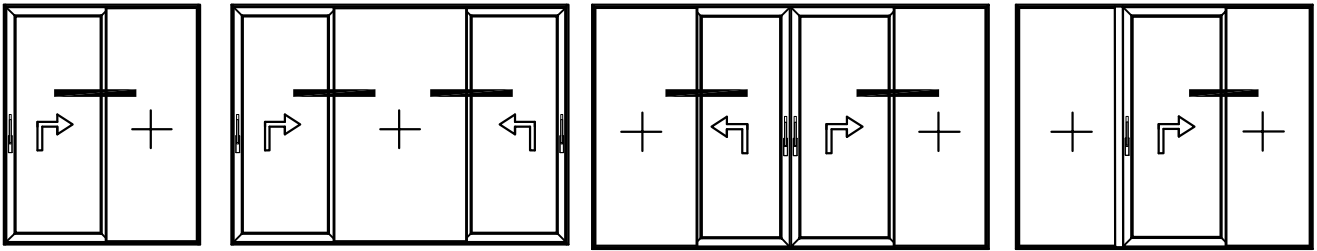

- Ljepljenje stakla za malo krilo FT-1121 i prečku FT-1130F
- Gluing glass on small sash FT-1121 and mullion FT-1130F

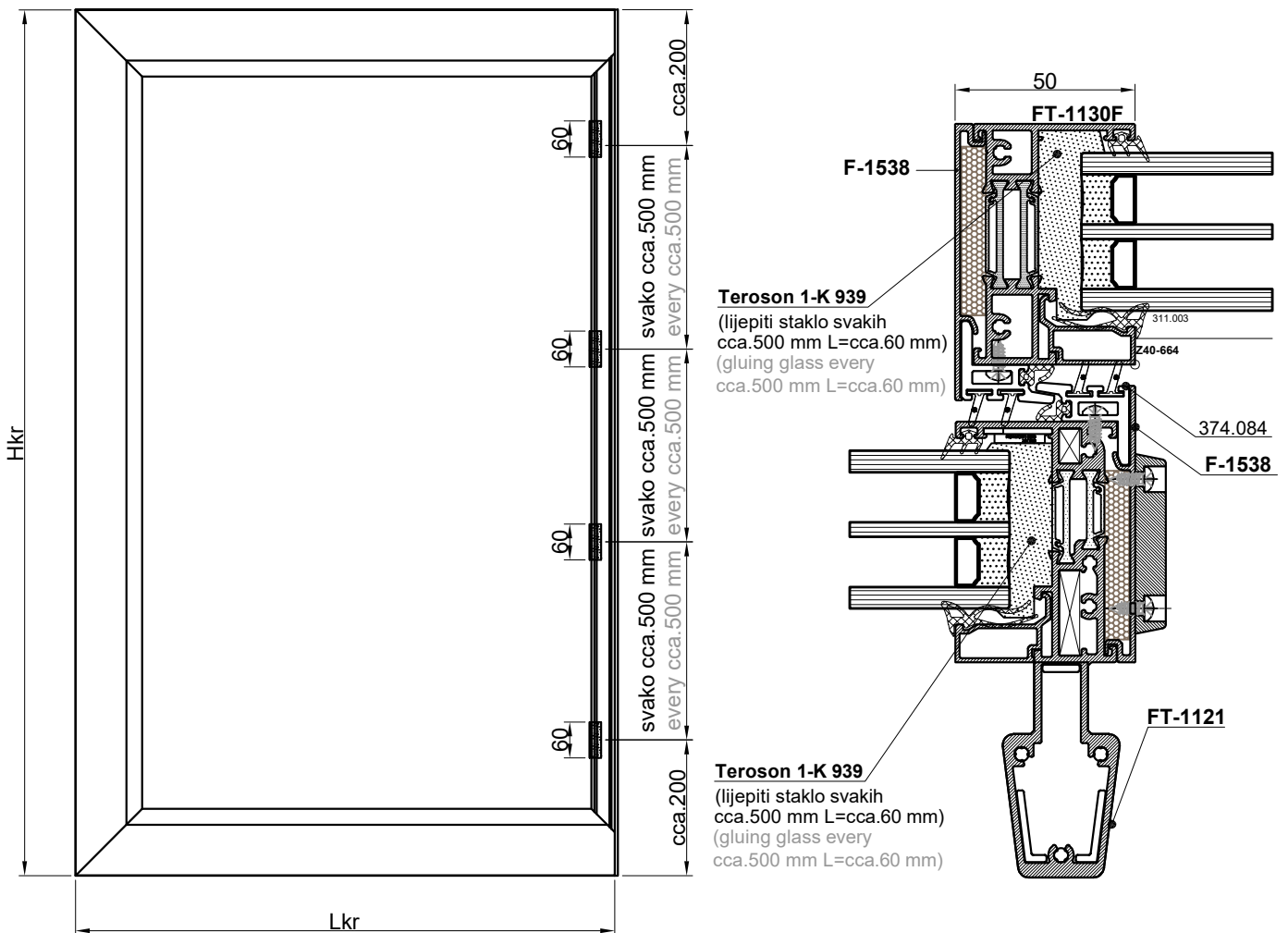

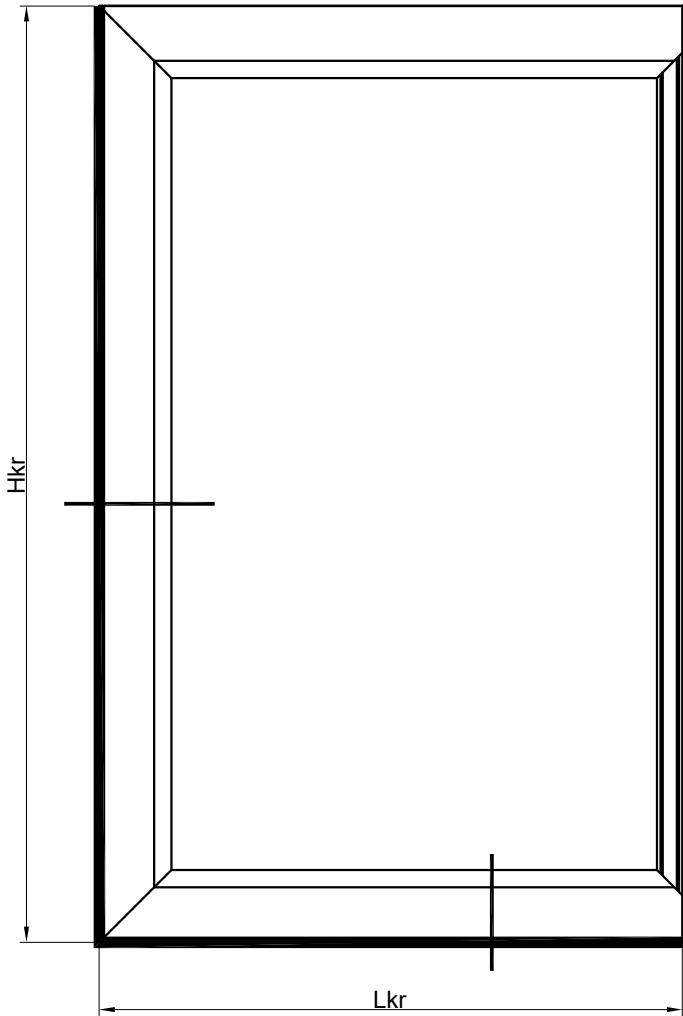

- Ljepljenje brtve 321.007 za krilo /Teroson MS 939/
- Gluing gasket 321.007 on sash /Teroson MS 939/

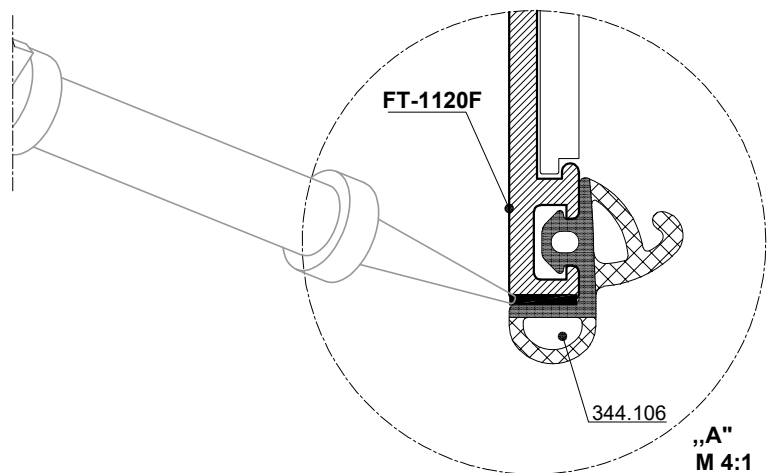
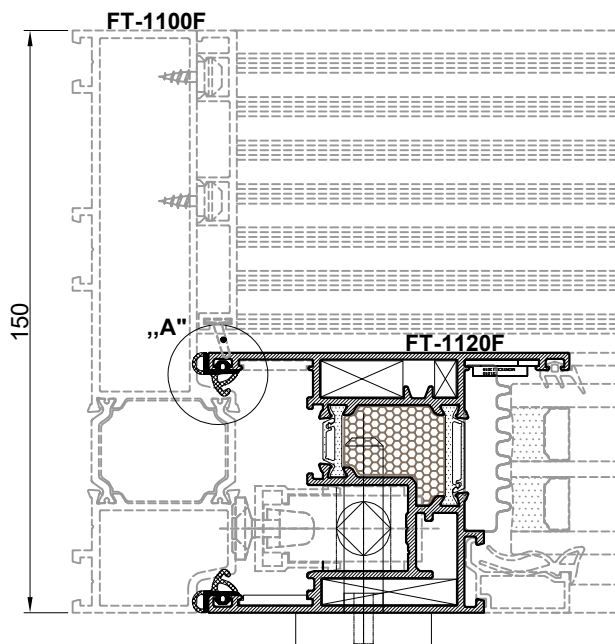
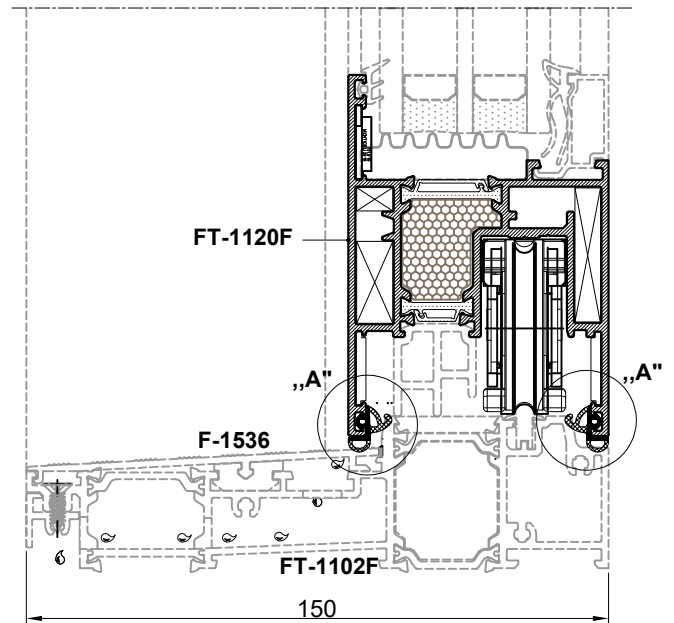

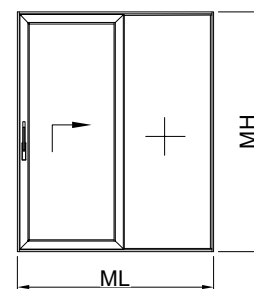
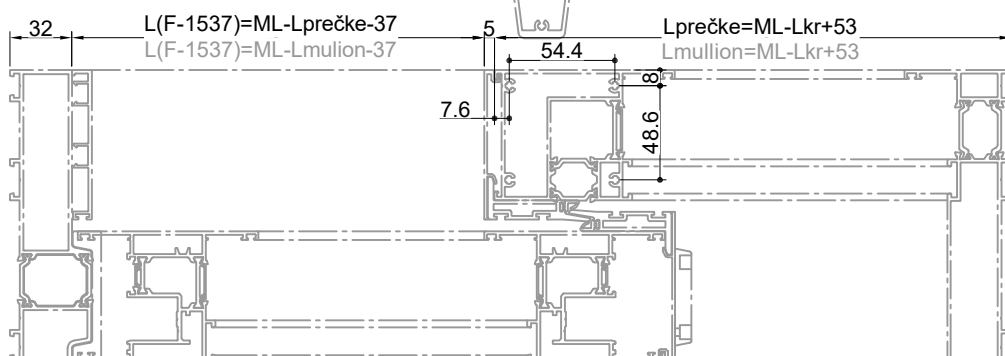
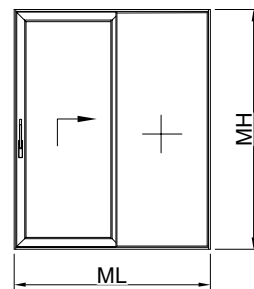
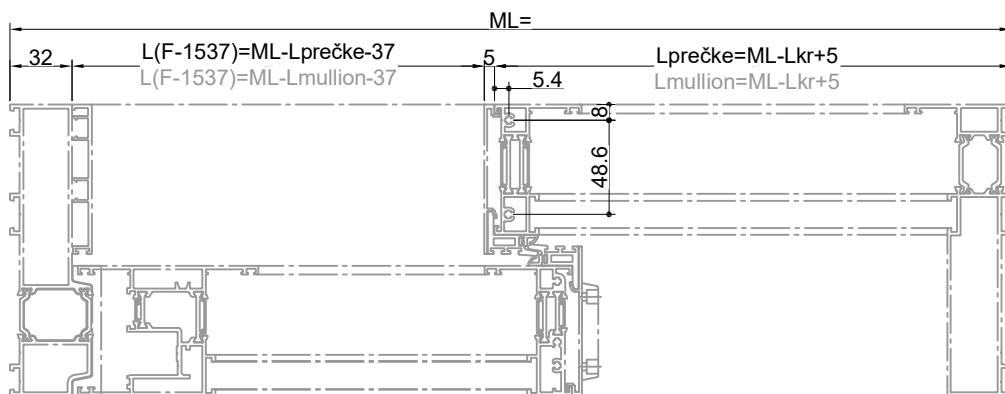

**POZICIONIRANJE POLOŽAJA PREČKE ZA SHEMU  
JEDNO KRILLO PODIZNO KLIZNO+FIKSNO I MASKE F-1537**

- prečka FT-1130F....Lprečke=ML-Lkr+5
- prečka FT-1131F....Lprečke=ML-Lkr+53
- maska F-1537.....L(F-1537)=ML-Lpreč-37

**POSITIONING LOCATION OF MULLION FOR SCHEME  
ONE SASH LIFT&SLIDE + FIXED AND MASK F-1537**

- mullion FT-1130F....Lmullion=ML-Lkr+5
- mullion FT-1131F....Lmullion=ML-Lkr+53
- mask F-1537.....L(F-1537)=ML-Lmullion-37

**POZICIONIRANJE POLOŽAJA PREČKE ZA SHEMU BOČNA  
KRILA PODIZNO KLIZNA+SREDNJE FIKSNO I MASKE F-1537**

- prečka FT-1130F....Lprečke=Lkr-5
- prečka FT-1131F....Lprečke=Lkr-53
- maska F-1537.....L(F-1537)=Lpreč-37

**POSITIONING LOCATION OF MULLION FOR SCHEME  
SIDE SASH LIFT&SLIDE + FIXED AND MASK F-1537**

- mullion FT-1130F....Lmullion=Lkr-5
- mullion FT-1131F....Lmullion=Lkr-53
- mask F-1537.....L(F-1537)=Lmullion-37

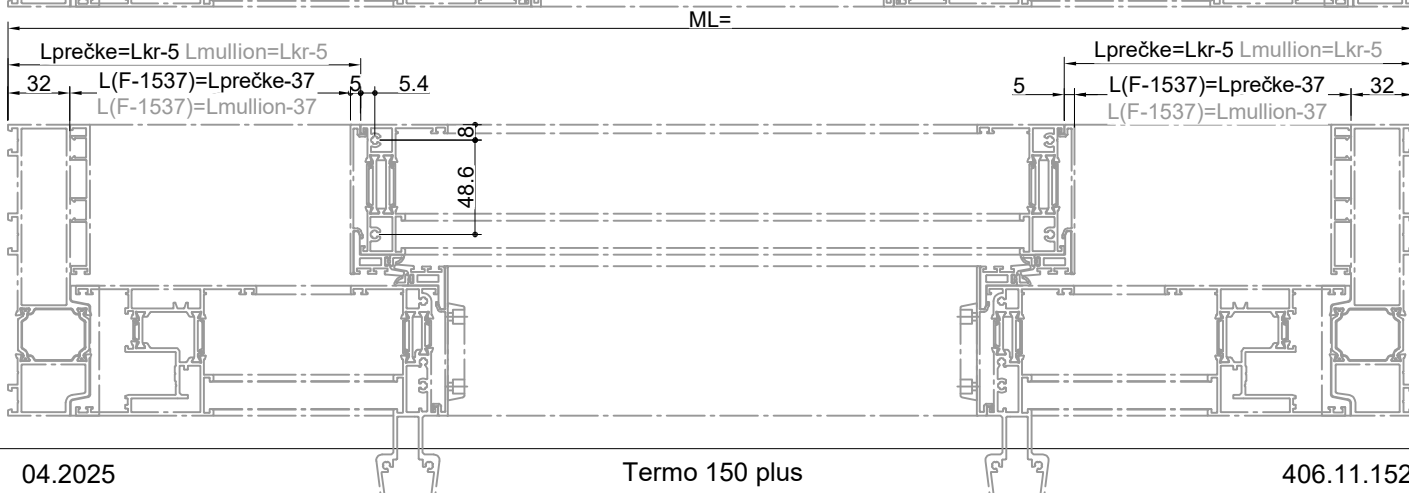
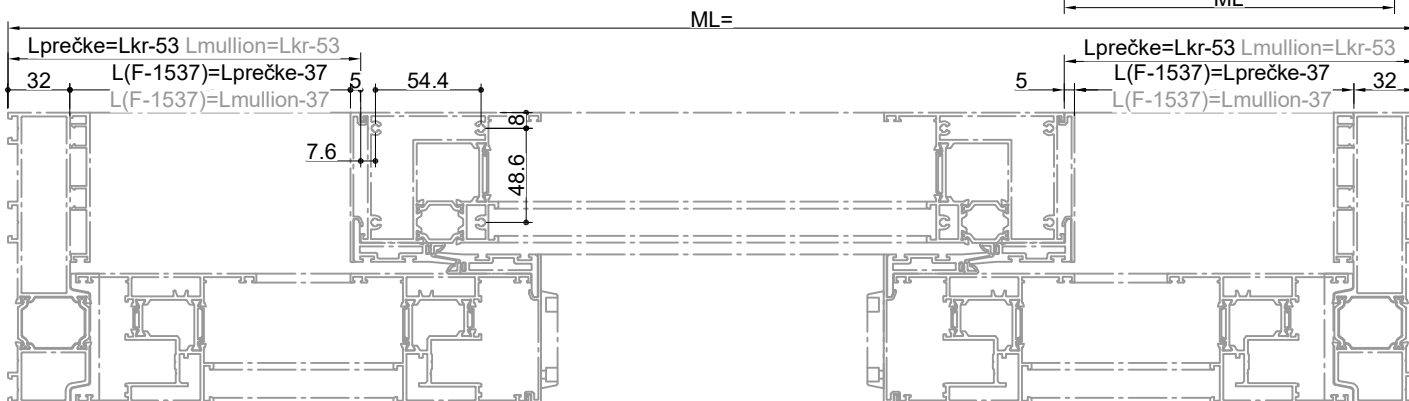
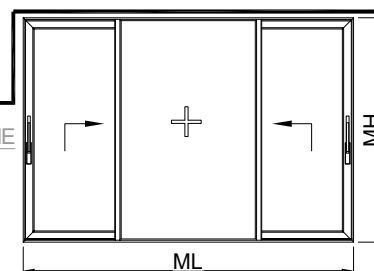

**POZICIONIRANJE POLOŽAJA PREČKE ZA SHEMU DVA SREDNJA  
KRILO PODIZNO KLIZNO+BOKOVI FIKSNI I MASKE F-1537**

- prečka FT-1130F.... $L_{pre\check{c}ke}=ML/4+39$
- prečka FT-1131F.... $L_{pre\check{c}ke}=ML/4+63$
- maska F-1537..... $L(F-1537)=ML-2L_{pre\check{c}k-10}$

**POSITIONING LOCATION OF MULLION FOR SCHEME TWO MIDDLE  
SASH LIFT&SLIDE+FIXED BLOCKS AND MASK F-1537**

- mullion FT-1130F.... $L_{mullion}=ML/4+39$
- mullion FT-1131F.... $L_{mullion}=ML/4+63$
- mask F-1537..... $L(F-1537)=ML-2L_{mullion-10}$

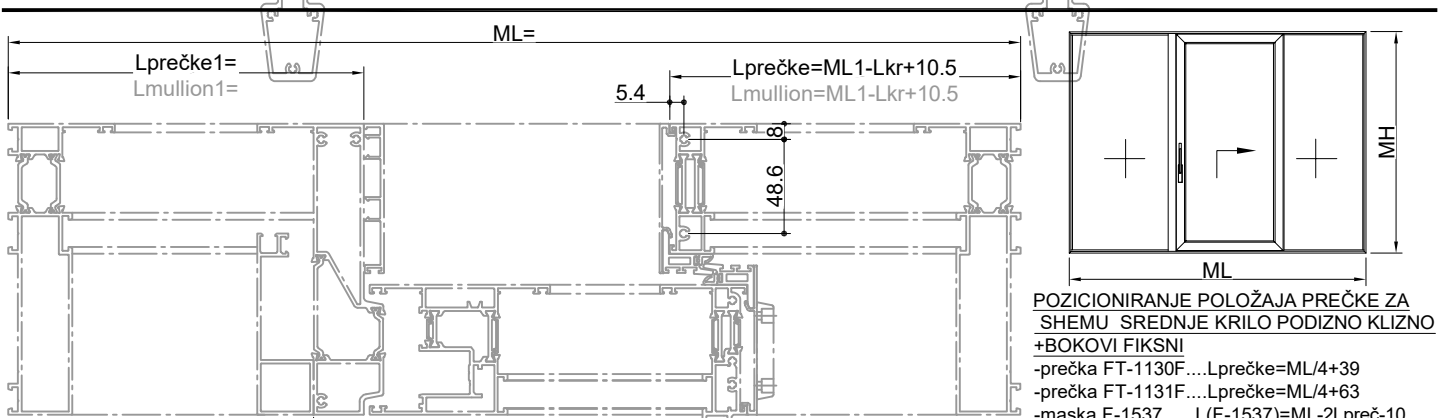
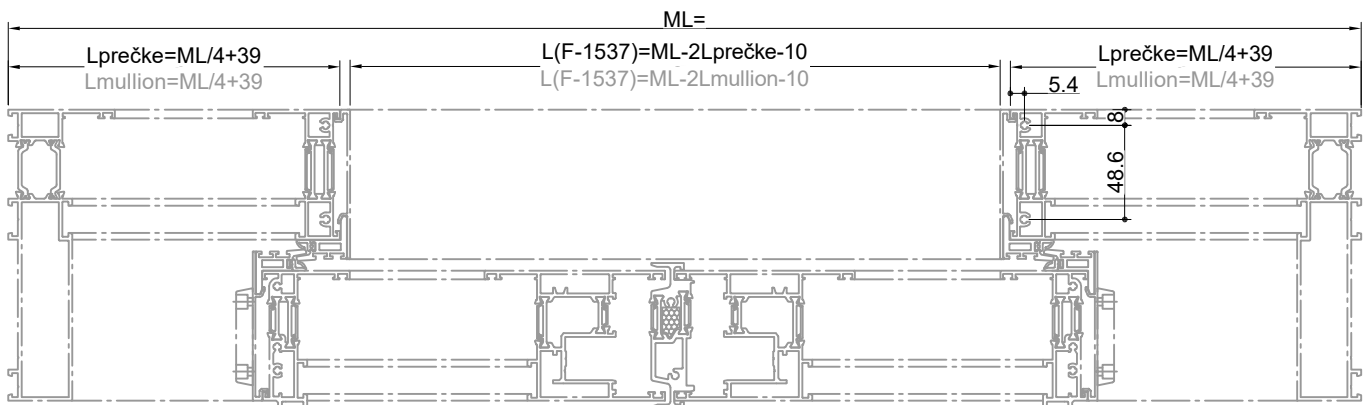
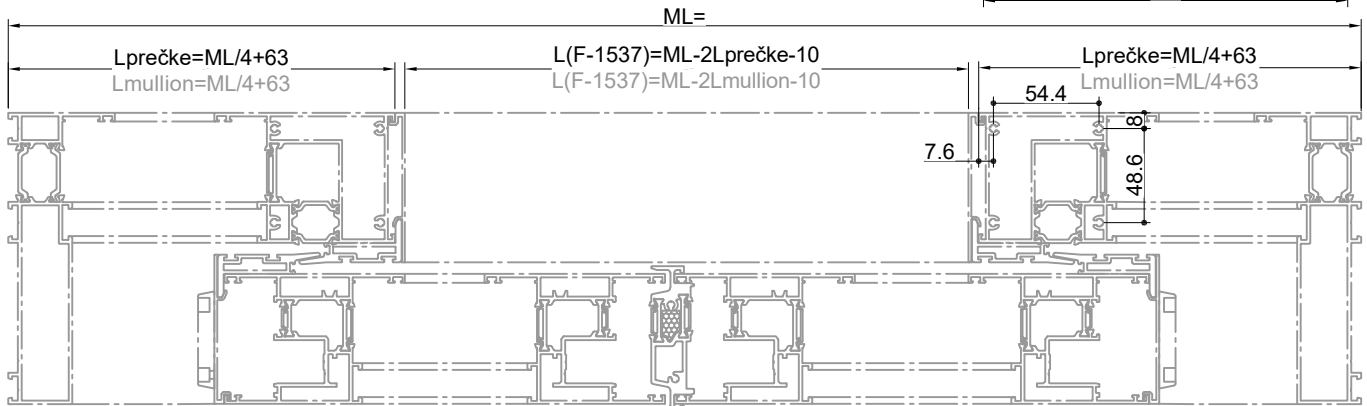
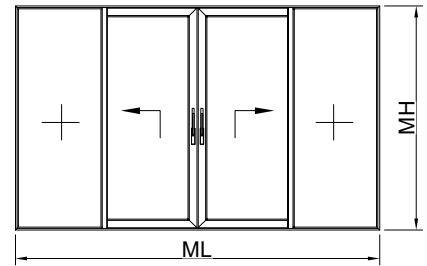

**POZICIONIRANJE POLOŽAJA PREČKE ZA  
SHEMU SREDNJE KRILO PODIZNO KLIZNO  
+BOKOVI FIKSNI**

- prečka FT-1130F.... $L_{pre\check{c}ke}=ML/4+39$
- prečka FT-1131F.... $L_{pre\check{c}ke}=ML/4+63$
- maska F-1537..... $L(F-1537)=ML-2L_{pre\check{c}k-10}$

**POSITIONING LOCATION OF MULLION FOR  
SCHEME MIDDLE SASH LIFT&SLIDE  
+ FIXED BLOCKS**

- mullion FT-1130F.... $L_{mullion}=ML/4+39$
- mullion FT-1131F.... $L_{mullion}=ML/4+63$
- mask F-1537..... $L(F-1537)=ML-2L_{mullion-10}$

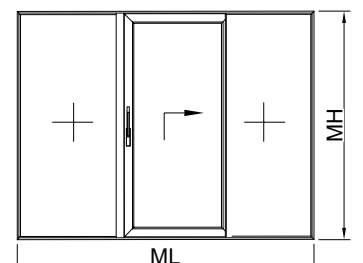
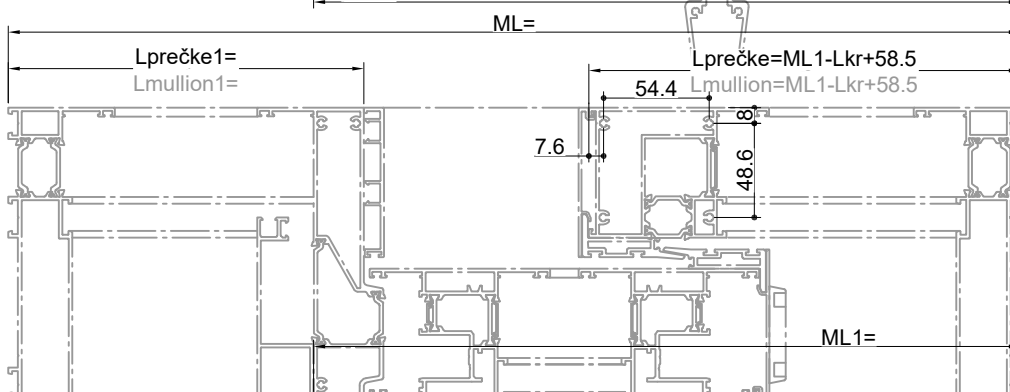

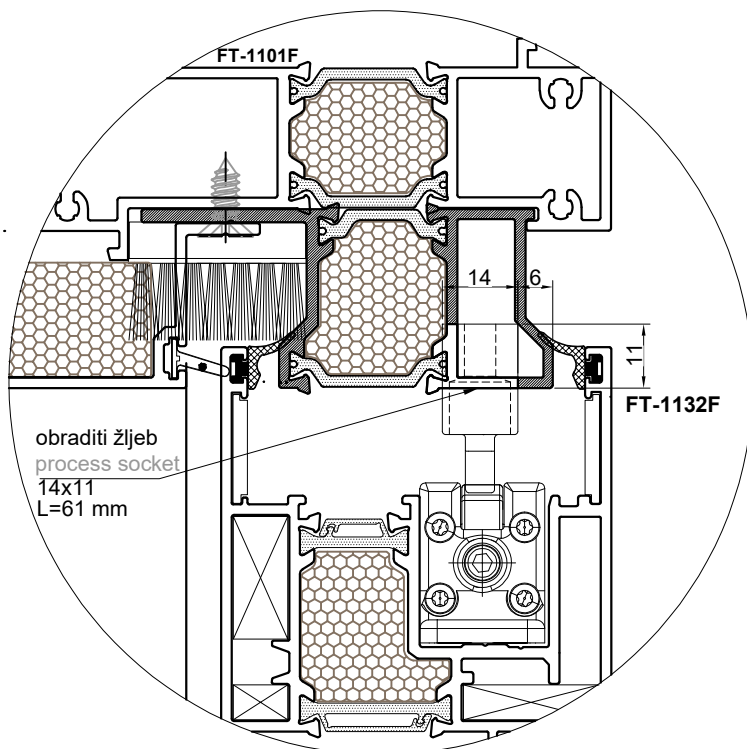
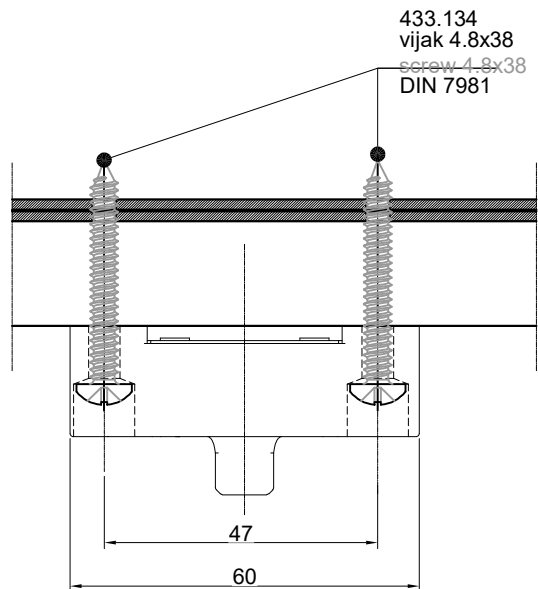

	<p><b>149.030</b>          - Usporivač krila za težine krila ≤ 200 kg          - Oznaka proizvođača:300359 (Atrium comfort close -HAUTAU)          - Sash weight retarder ≤ 200 kg          - Manufacturer code:300359 (Atrium comfort close -HAUTAU)</p>	<p><b>149.031</b>          - Usporivač krila za težine krila &gt; 200....300 kg          - Oznaka proizvođača:300360 (Atrium comfort close -HAUTAU)          - Sash weight retarder &gt; 200....300 kg          - Manufacturer code:300360 (Atrium comfort close -HAUTAU)</p>
--	---	---

	<p><b>149.032</b>          - Usporivač krila-dodatak na ramu          - Oznaka proizvođača:300380 (Atrium comfort close -HAUTAU)          - Sash retarder -addition on frame          - Manufacturer code:300380 (Atrium comfort close -HAUTAU)</p>
--	---

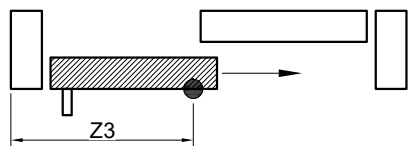

Z3= FB-69

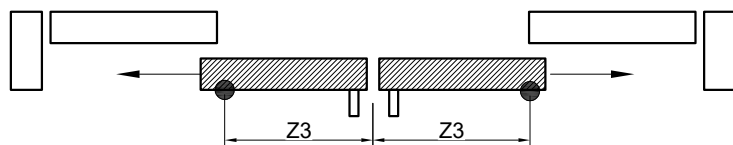
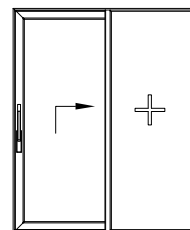

Z3= FB-107

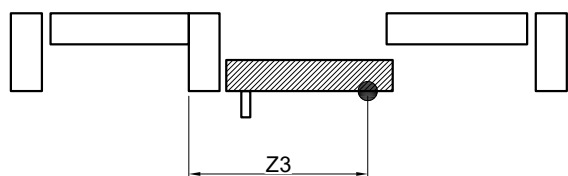
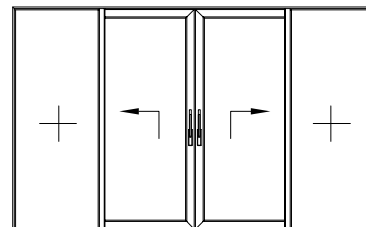

Z3= FB-69

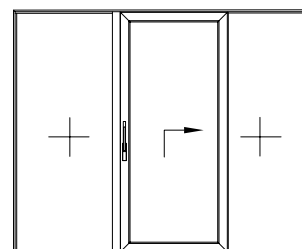

FB-širina krila  
 FB-sash width

- pozicija usporivača (dio na ramu)....149.032
- supprt position (part on frame)....149.032

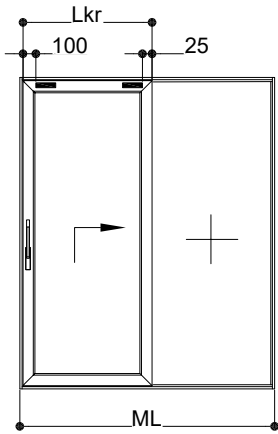

**UGRADNJA USMJERIVAČA KRILA 373.078**  
(4 kom. po krilu)-kad imamo usporivač udara  
**ATRIUM COMFORT CLOSE**  
**SASH GUIDE MOUNTING 373.078**  
(4 pcs. per sash)-for sash retarder **ATRIUM**  
**COMFORT CLOSE**

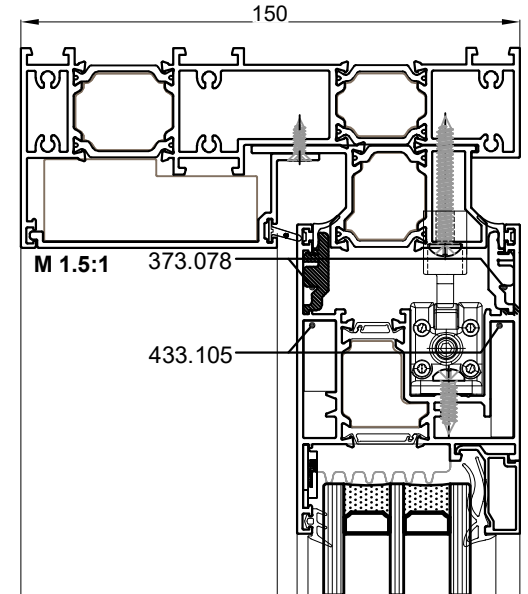
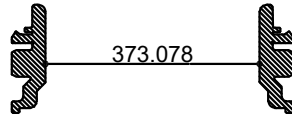

**Pozicija  
montiranja**  
Mounting  
position



usporivač udara  
comfort close

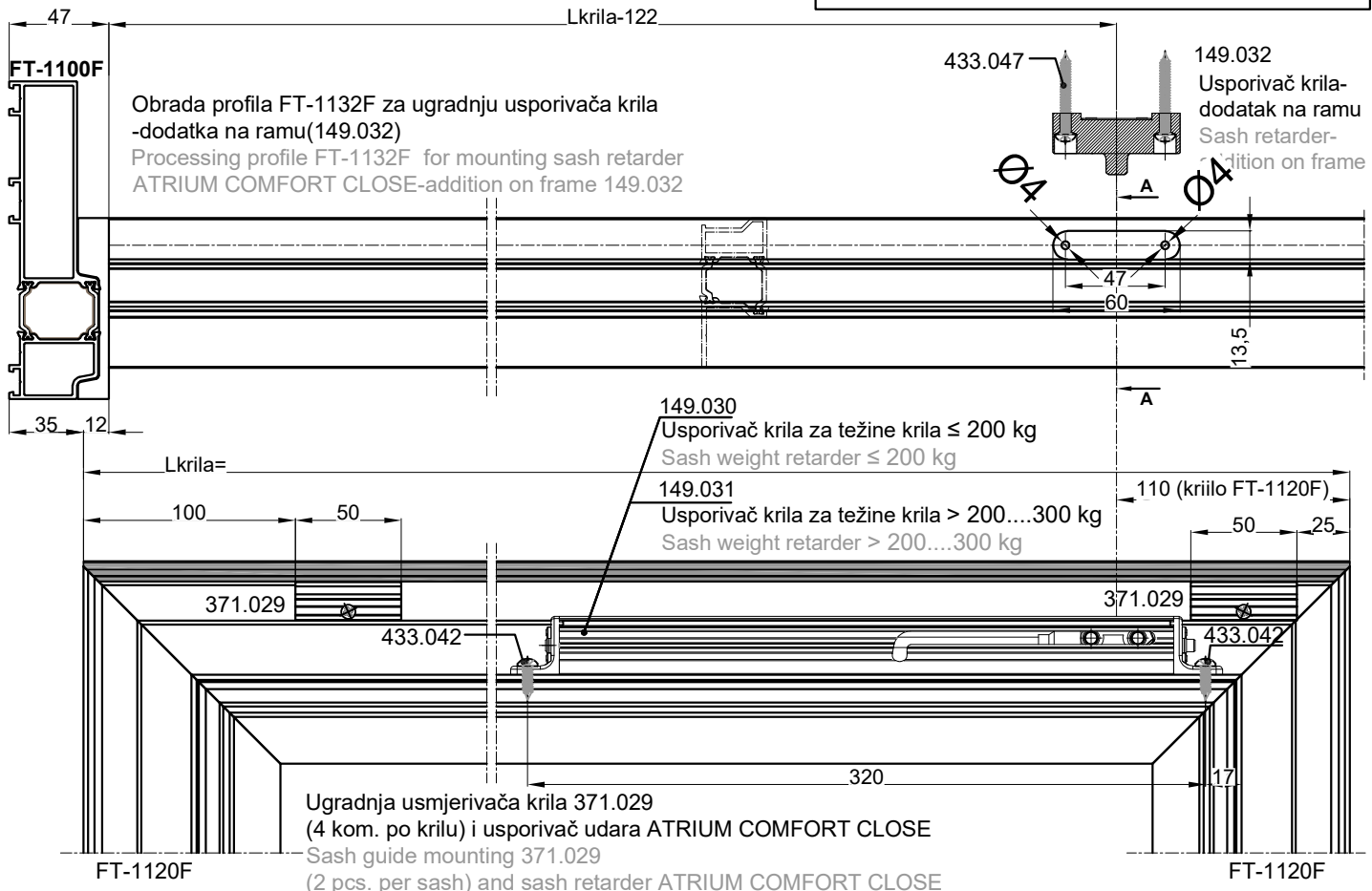
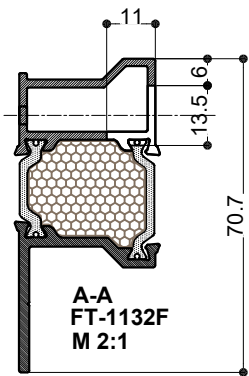
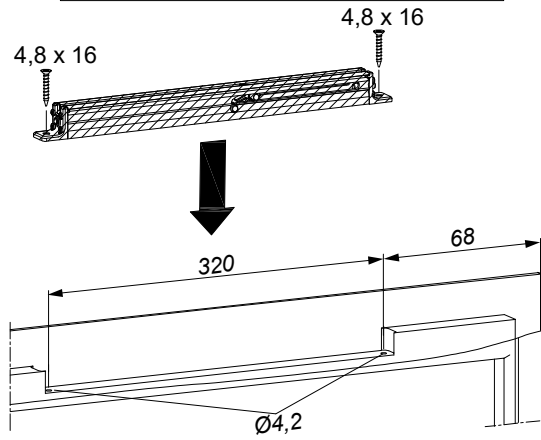
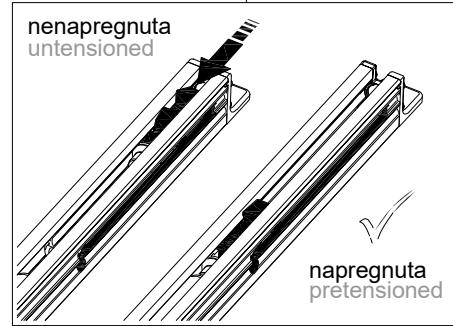
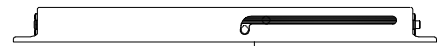

- Mogućnost podešavanja
- Adjustment option

U slučaju netočnosti u pogledu položaja dijela koji ide na ram, krajnji položaj krila povezan s ramom može se podesiti. Postaviti ključ veličine 3 u utor 6x4 mm u utoru za podešavanje.

L (rotacija u smjeru suprotnom od kazaljke na satu): zatvaranje krila će se pomaknuti u smjeru strane ručke (0 ... 5 mm).

R (rotacija u smjeru kazaljke na satu): zatvaranje krila će se pomaknuti u smjeru strana bez ručke (0 ... 5 mm)

In case of inaccuracy concerning position of the frame piece, the end position of the sash related to the frame can be adjusted. Put allen key size 3 through the groove 6 x 4 mm into the adjusting screw.

L (counter-clockwise rotation): closing of sash will be shifted in direction of handle side (0 ... 5 mm).

R (clockwise rotation): closing of sash will be shifted in direction of non-handle side (0 ... 5 mm)

**- NAPOMENA:**

Podešavati se može nakon ostakljivanja krila i montaže na ram.

**- NOTE:**

Adjustments may be changed after glazing the sash and mounting the frame!

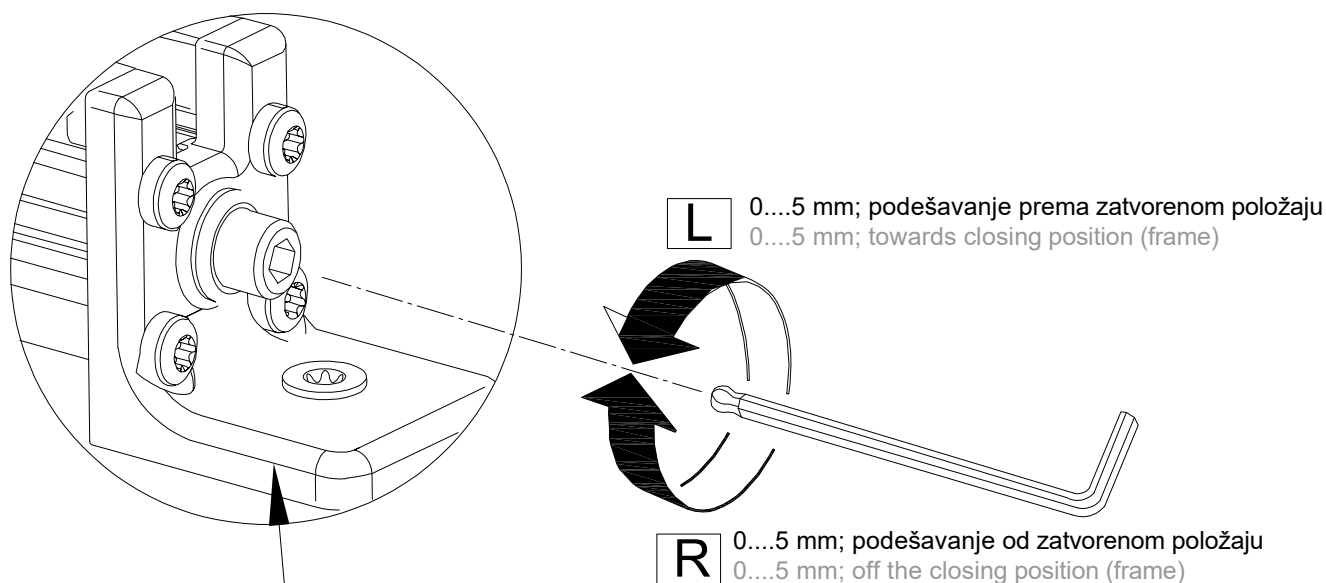

podešavanje položaja zatvaranje  
adjustment at closing edge

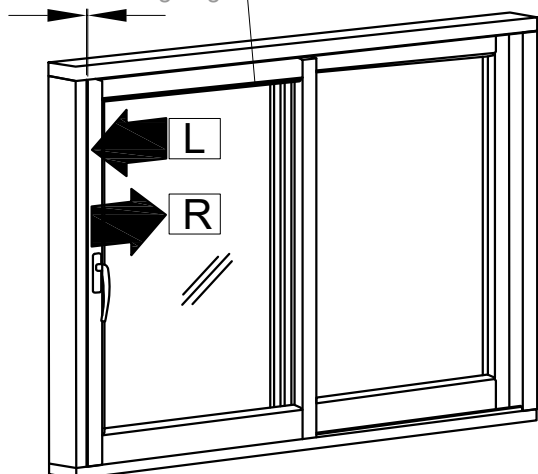

### Obrada profila krila za skriveni odvod kapljevina

- izvod kapljevina iz krila pomoću **monodrain cjevčice 360.009**
- obradu profila raditi glodalom ili svdlom  $\varnothing 10$  svakih 600 mm (250 mm od krajeva profila)

### Processing of sash profile for hidden drainage

- drainage from sash by monodrain tubule 360.009
- process profile with mill or bore  $\varnothing 10$  every 600 mm (250 mm from the end of profile)

### Ugradnja monodrain cjevčice 360.009 Mounting of monodrain tubule 360.009

#### Obrada profila krila FT-1120F Processing of sash profile FT-1120F

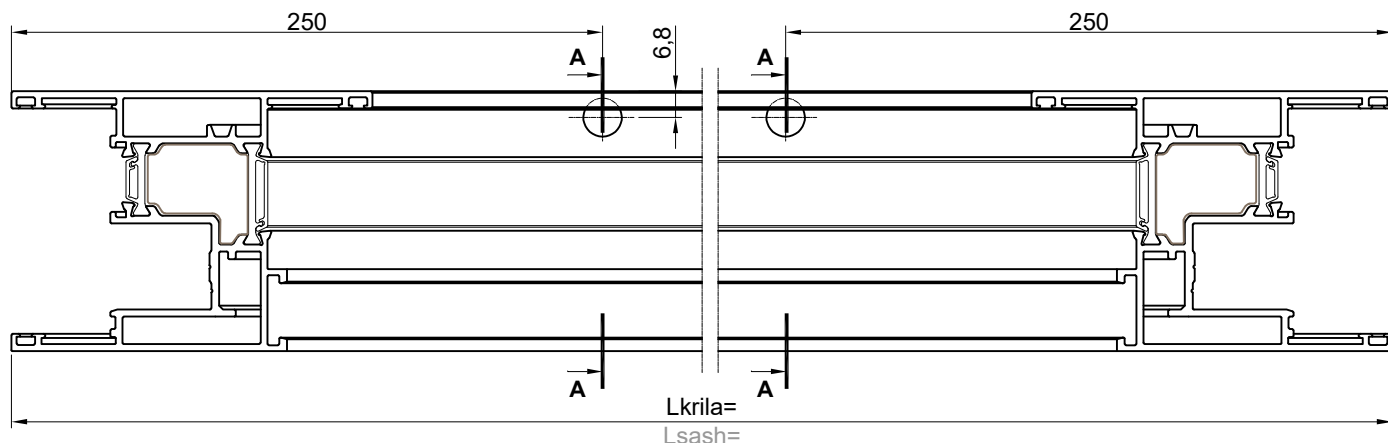
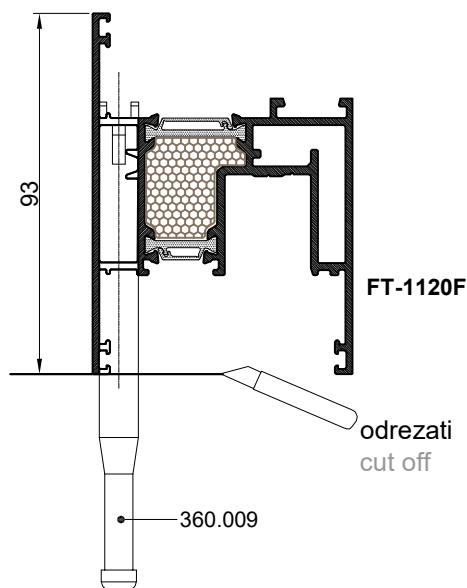
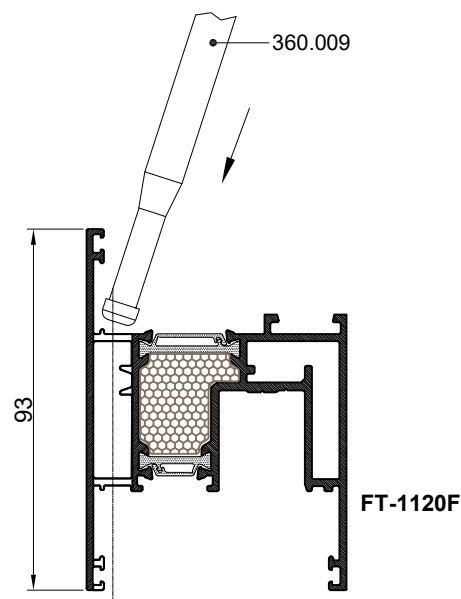
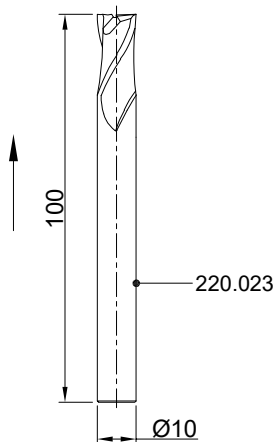
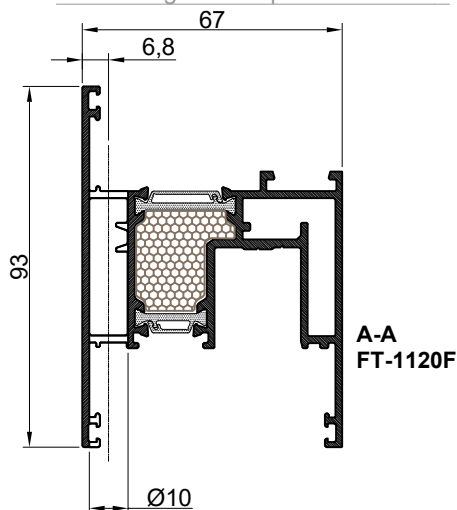

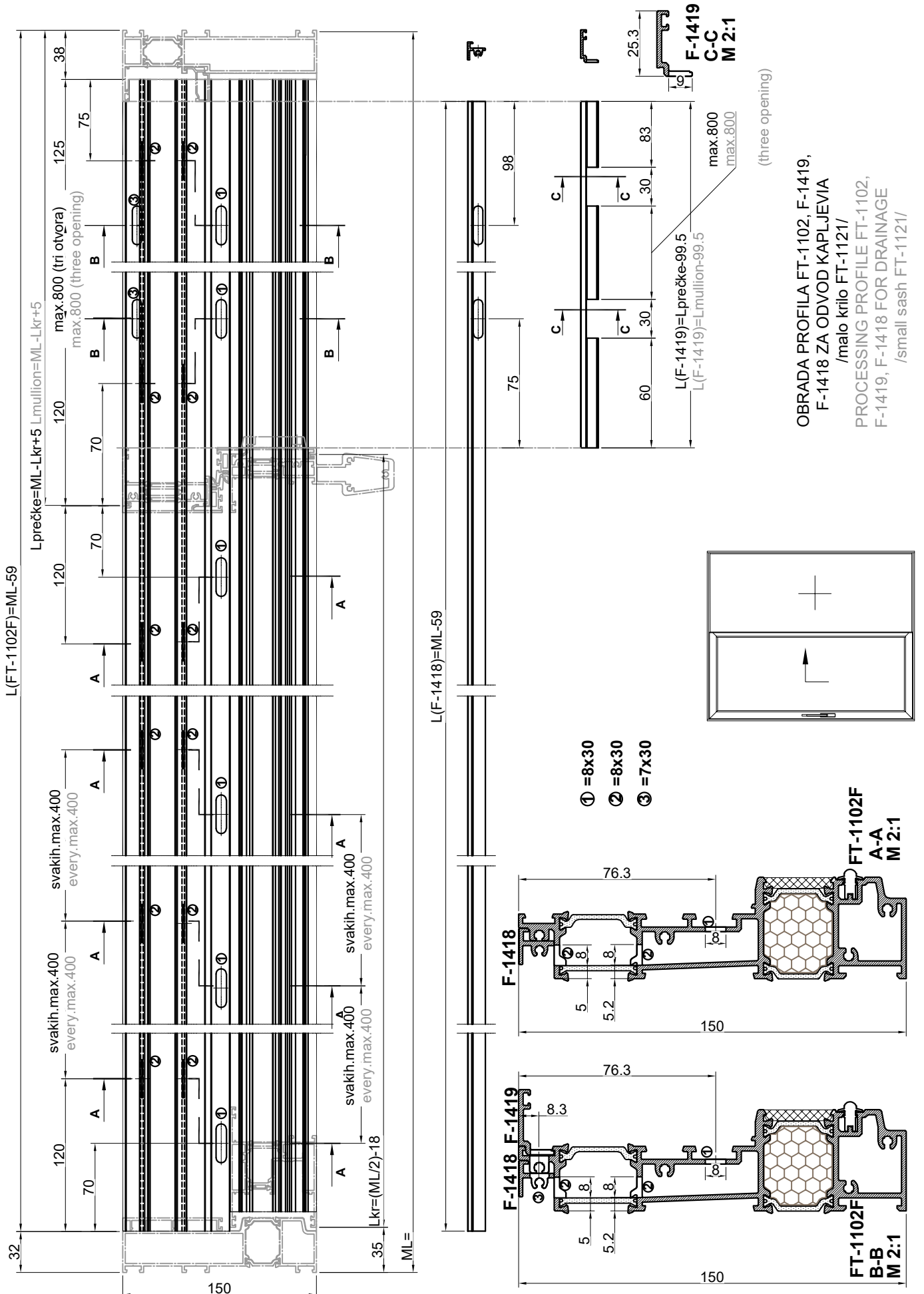

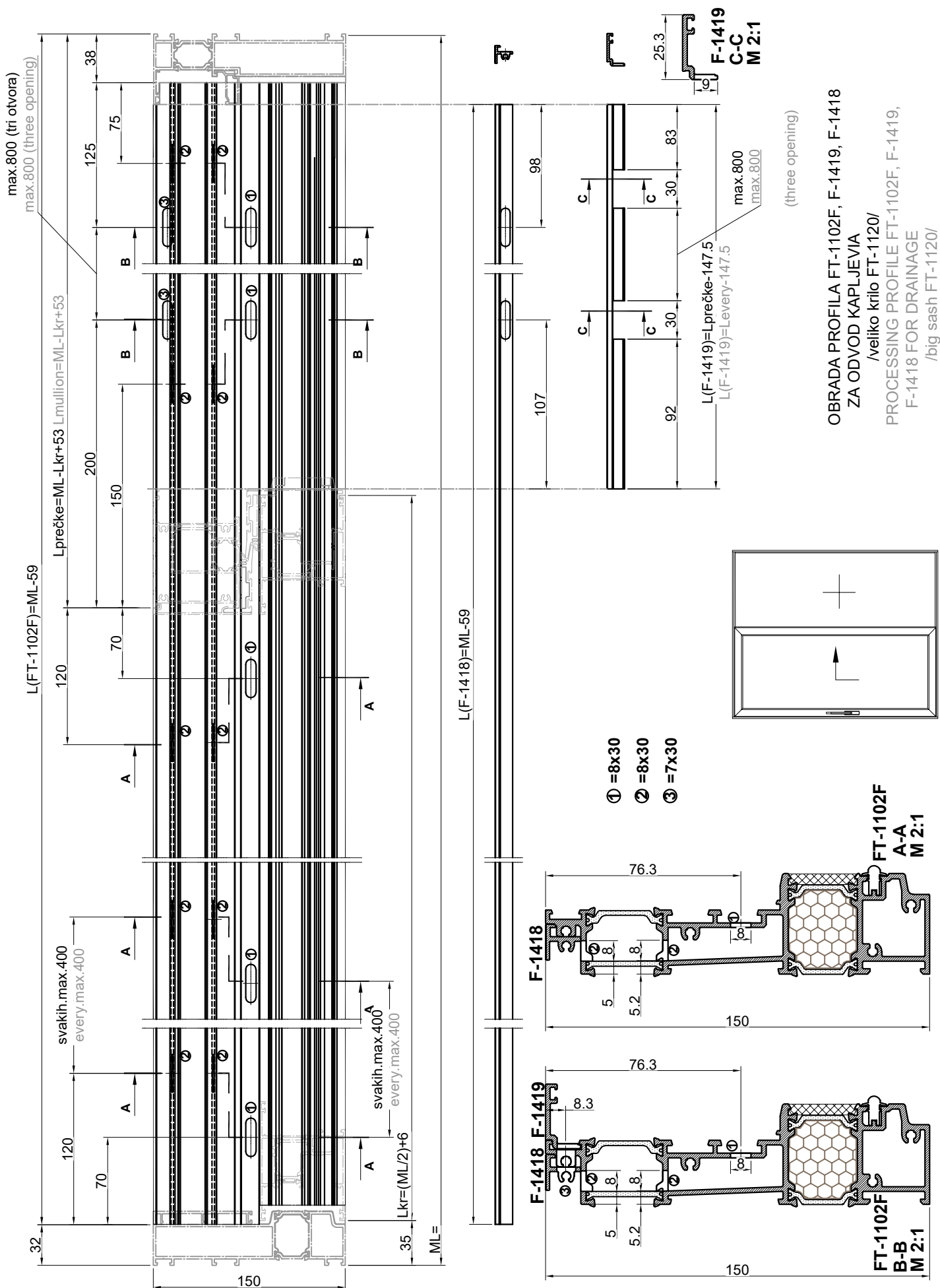



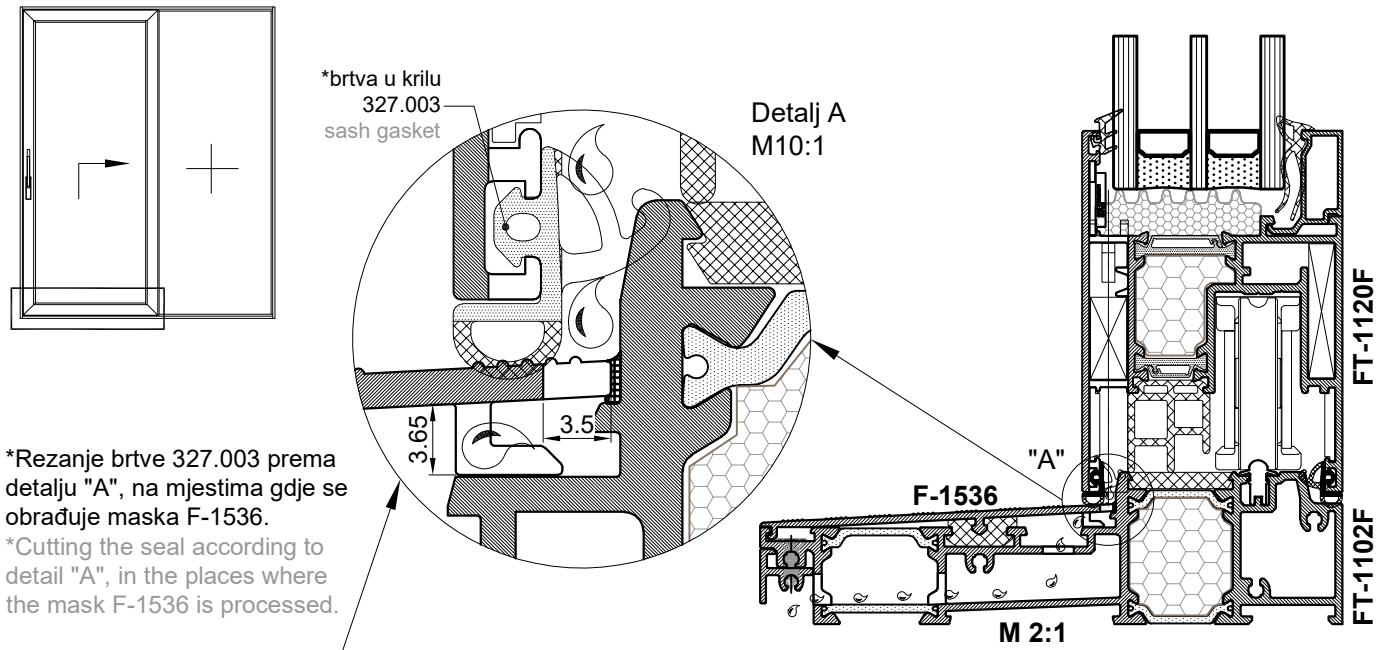

F-1536  
D-D  
M1:1

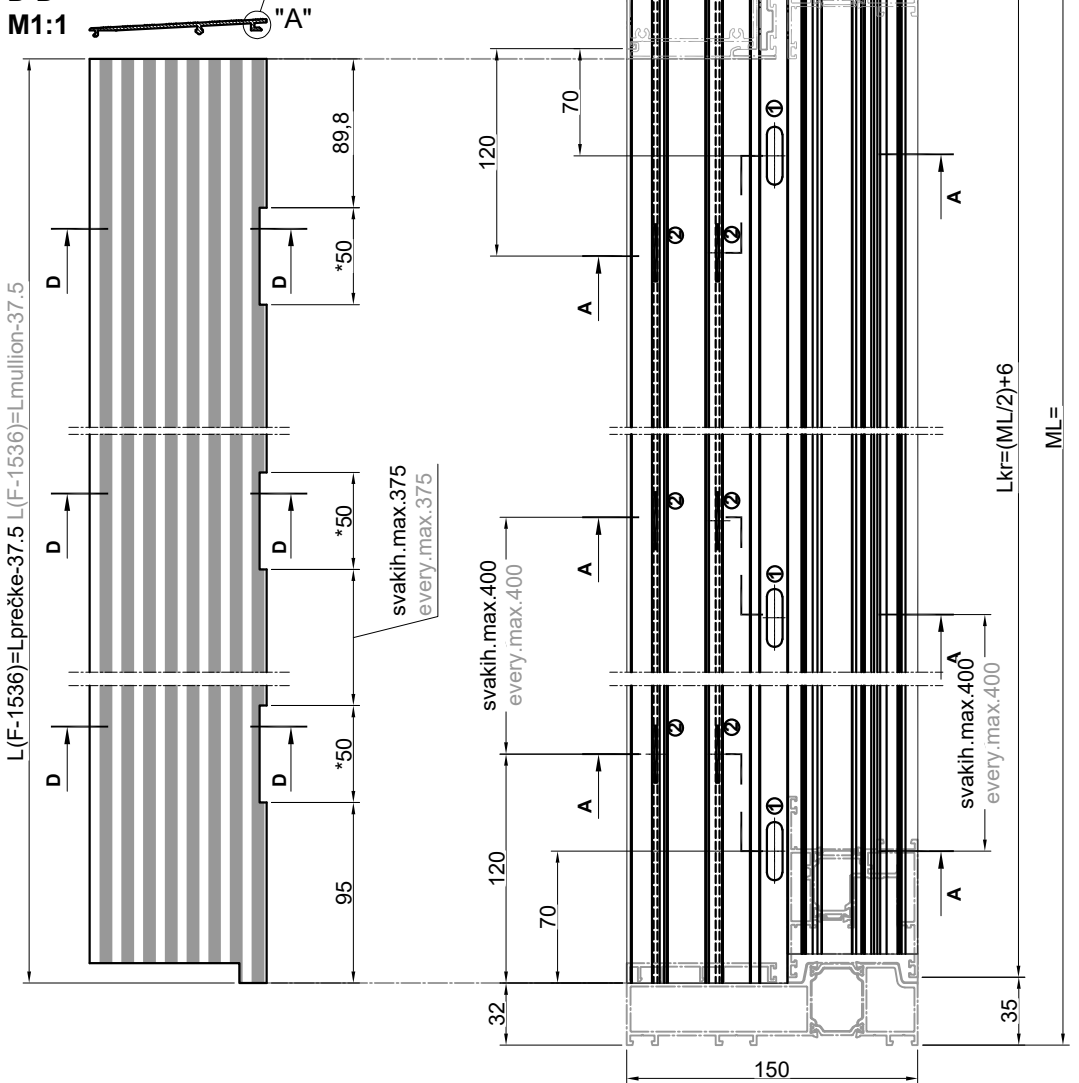

OBRADA PROFILA MASKE F-1536 ZA  
ODVOD KAPLJEVIA  
/veliko krilo FT-1120F/  
PROCESSING MASK PROFILE F-1536  
FOR DRAINAGE  
/big sash FT-1120F/

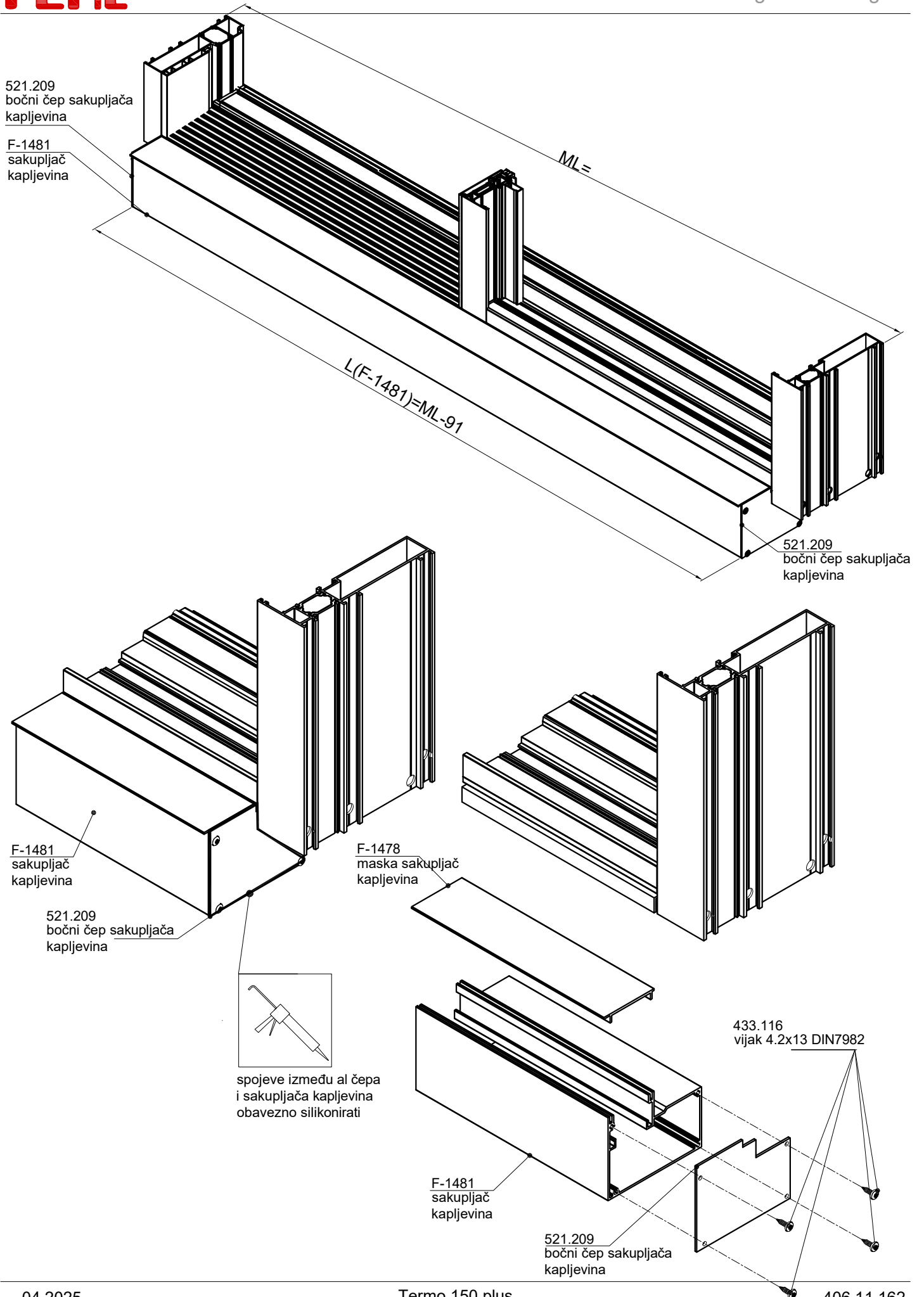

OBRADA ZA BRAVU Atrium Alu-HS 200 (Hautau)  
-obrada na glodalici vretenastim glodalom  
za krilo FT-1120F

PROCESSING FOR ESPAG. Atrium Alu-HS 200 (Hautau)  
-processing on mill machine with end mill  
for sash FT-1120F

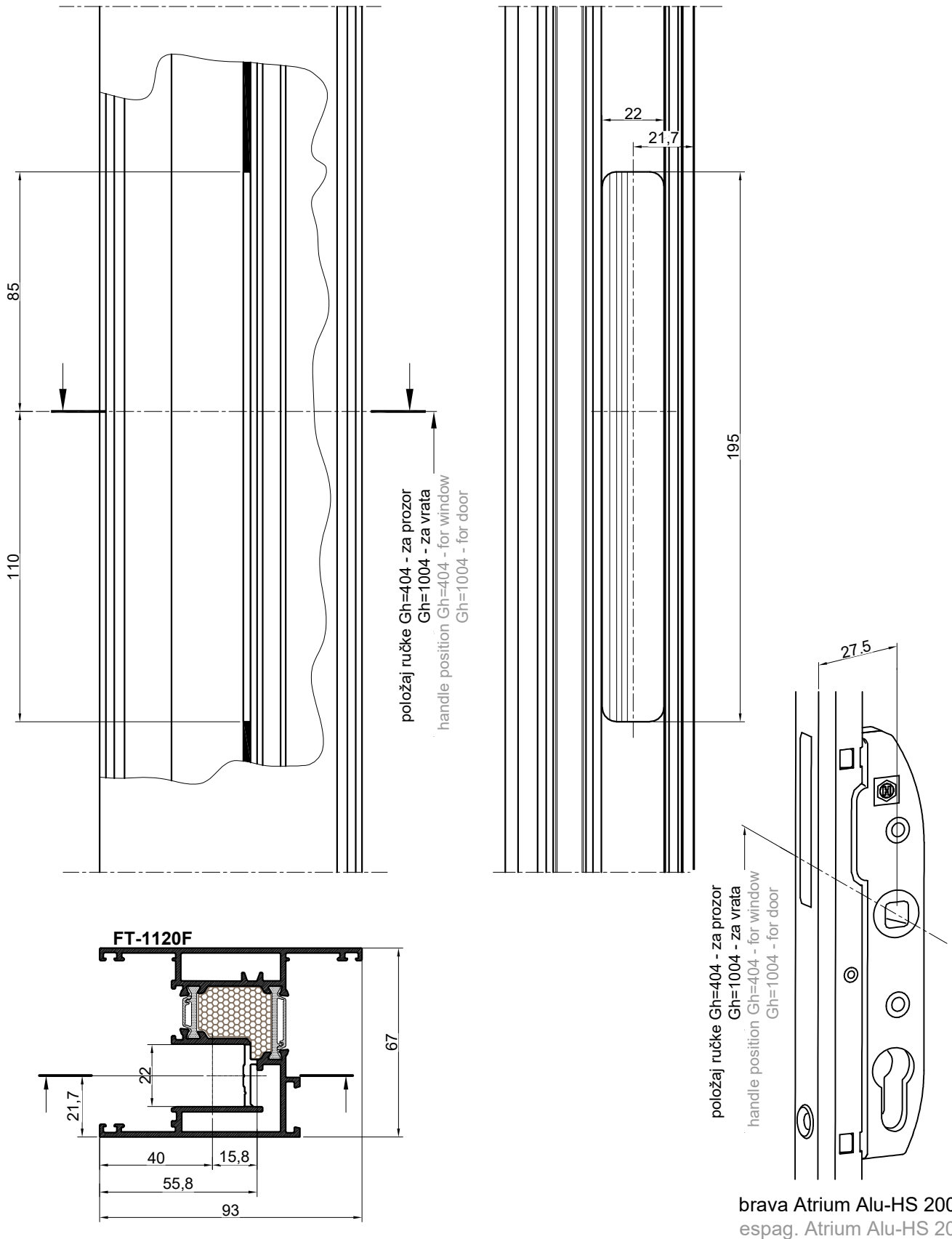

OBRADA PROFILA FT-1120F ZA RUČKU 108.006, Hautau, za HS 200  
PROCESSING PROFILE FT-1120F FOR HANDLE 108.006, Hautau, za HS 200

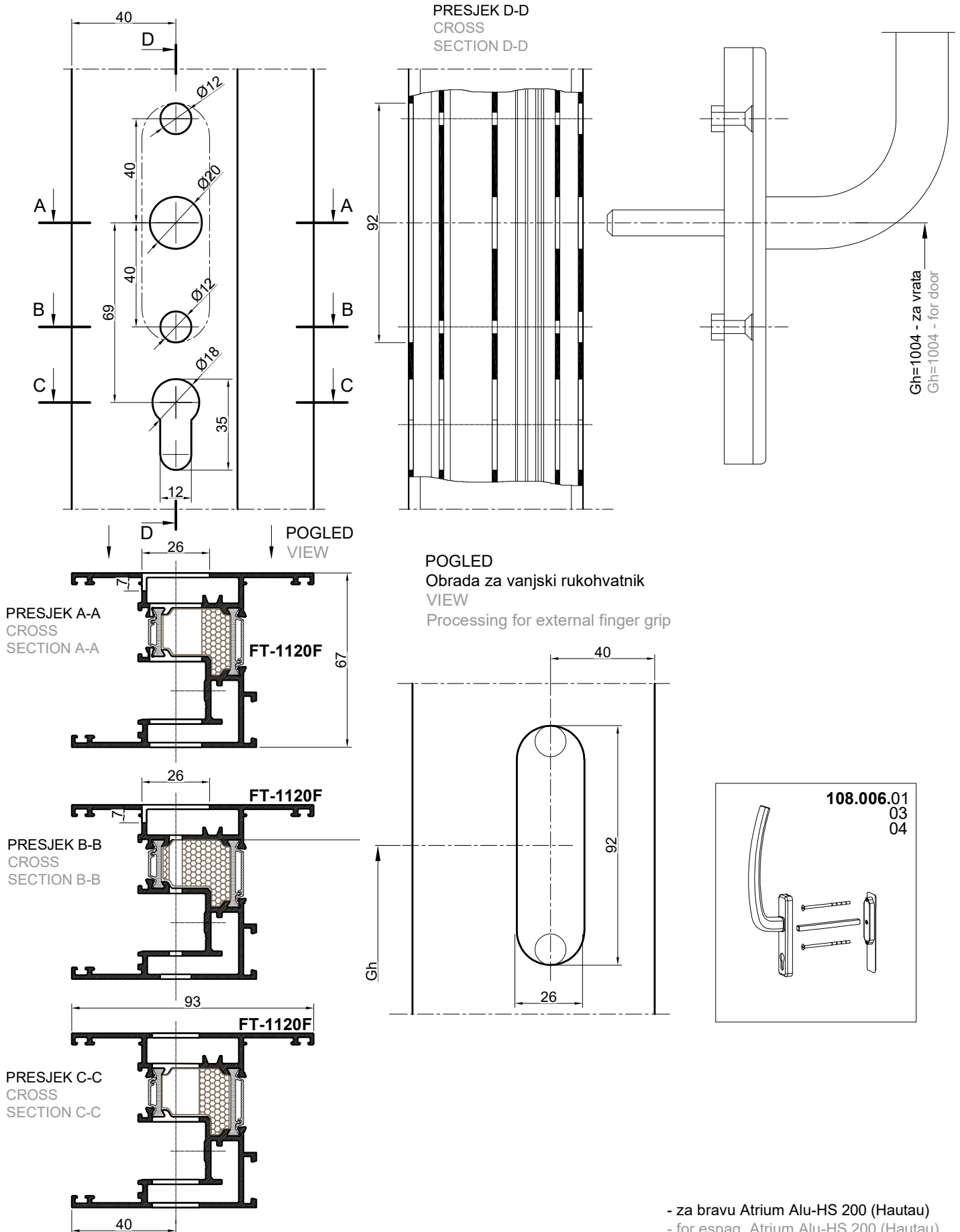

**OBRADA PROFILA FT-1120F ZA RUČKU 108.007, Hautau, za HS 200**  
**PROCESSING PROFILE FT-1120F FOR HANDLE 108.007, Hautau, za HS 200**

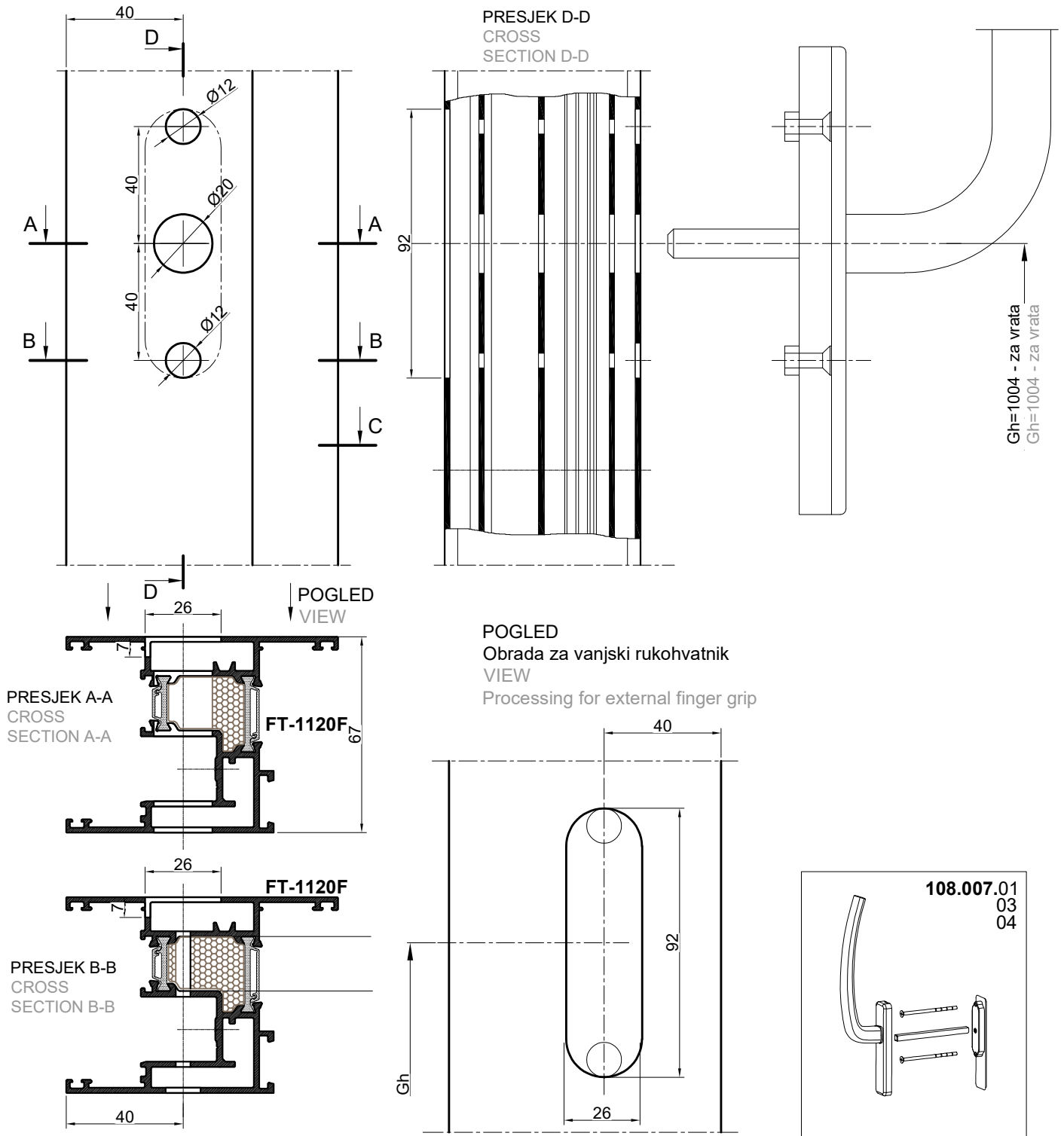

- za bravu Atrium Alu-HS 200 (Hautau)  
- for espag. Atrium Alu-HS 200 (Hautau)

**OBRADA PROFILA FT-1120F ZA RUČKU 108.001, Hautau, za HS 200**  
**PROCESSING PROFILE FT-1120F FOR HANDLE 108.001, Hautau, za HS 200**

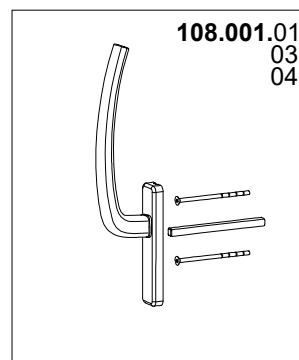
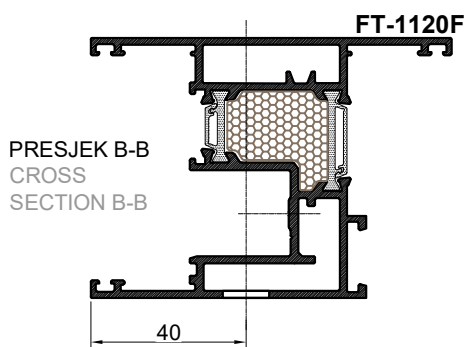
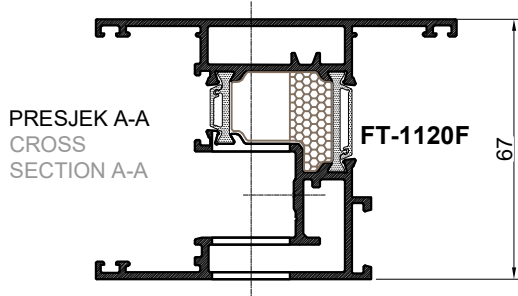
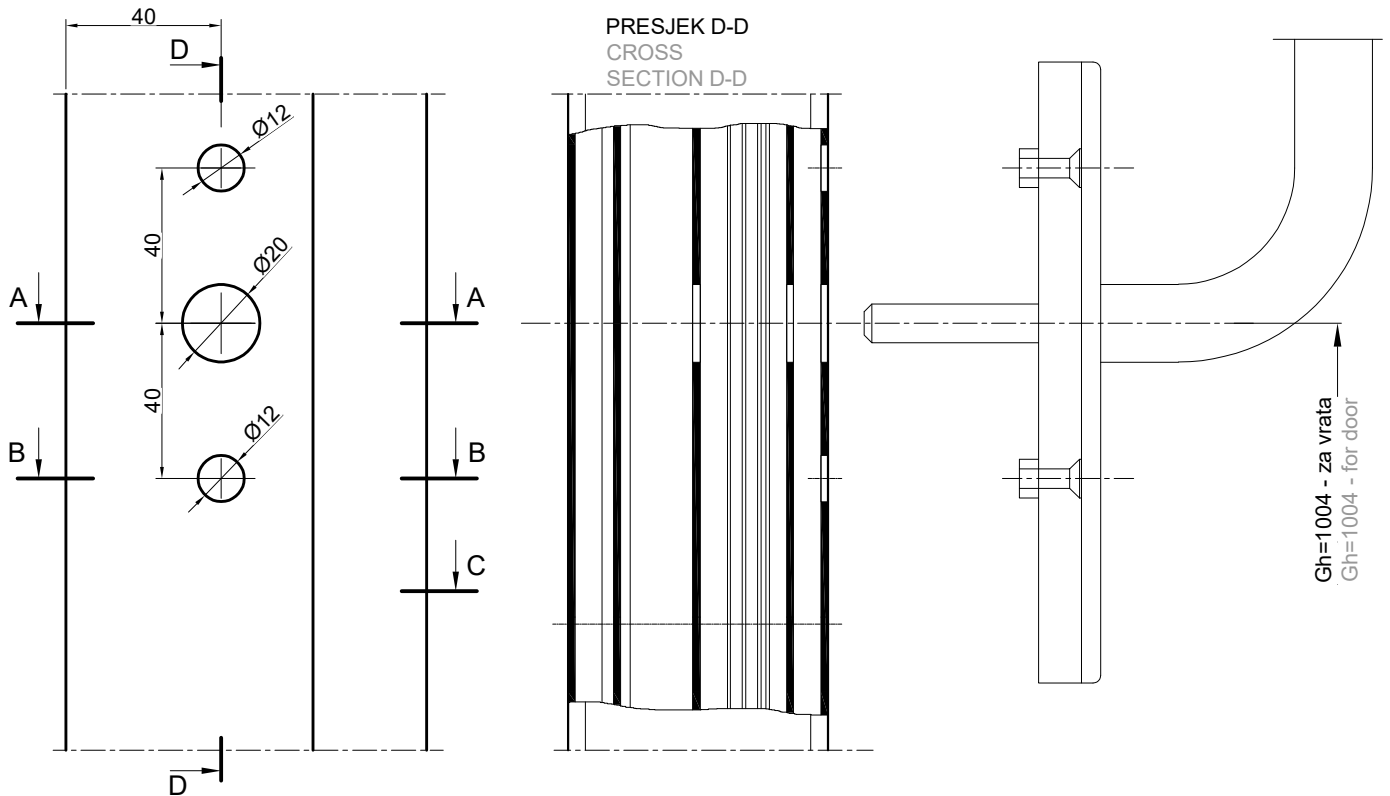

- za bravu Atrium Alu-HS 200 (Hautau)  
- for espag. Atrium Alu-HS 200 (Hautau)

**OBRADA PROFILA FT-1120F ZA RUČKU 108.008, Hautau, za HS 200**  
**PROCESSING PROFILE FT-1120F FOR HANDLE 108.008, Hautau, za HS 200**

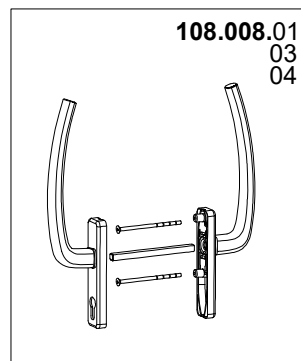
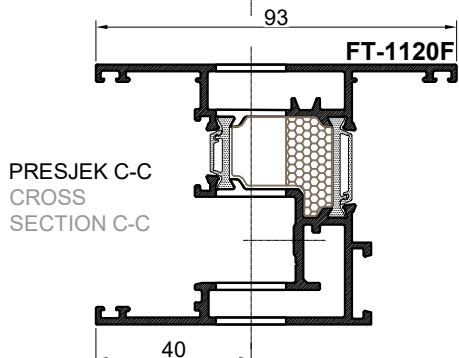
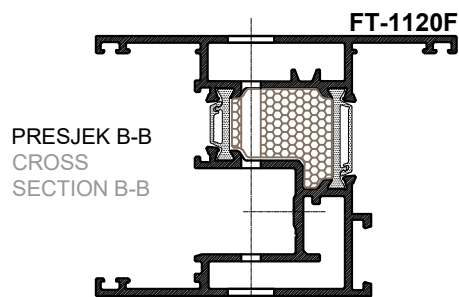
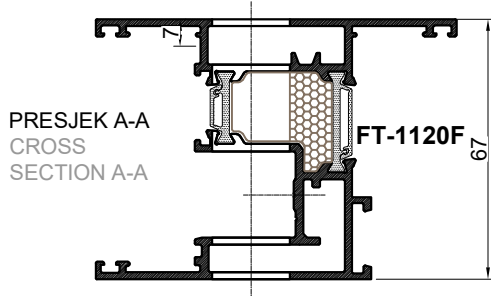
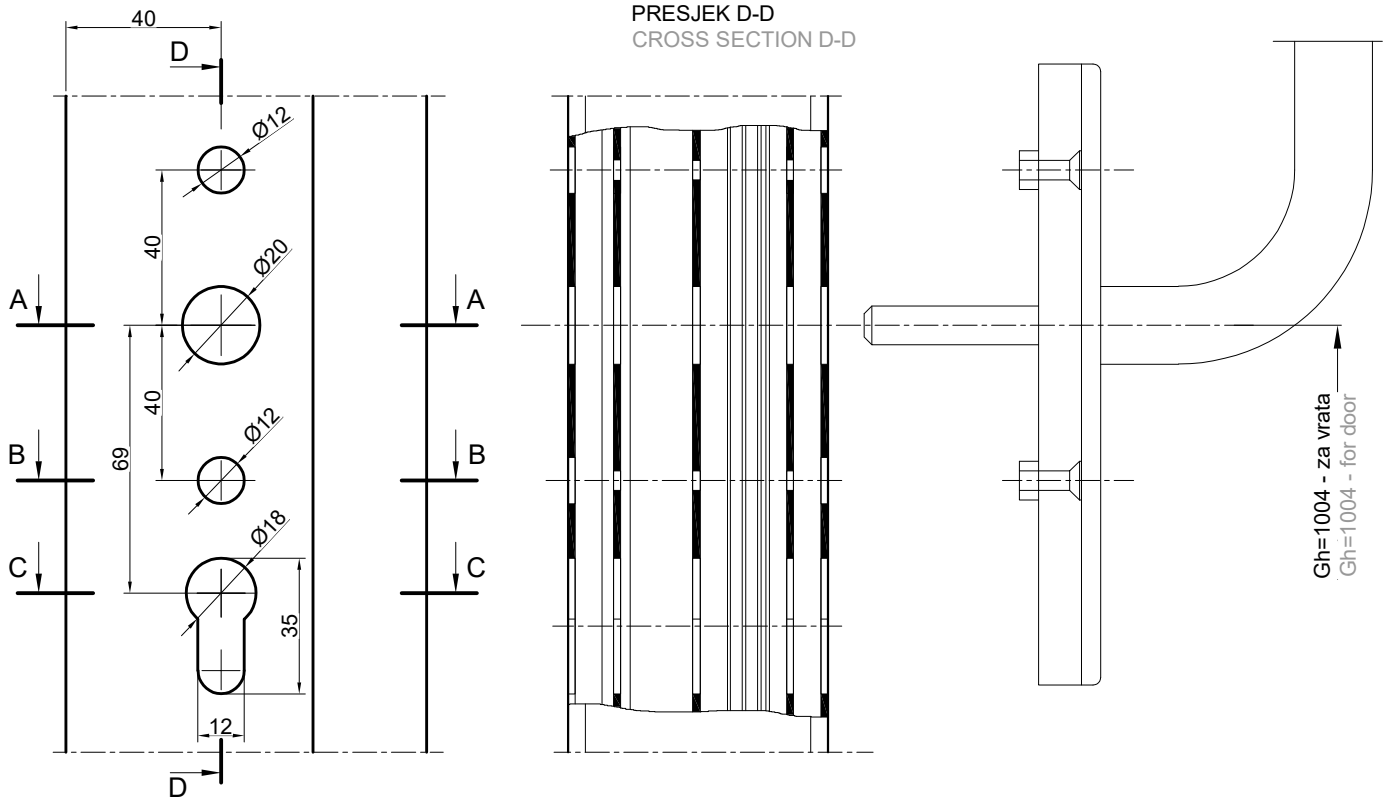

- za bravu Atrium Alu-HS 200 (Hautau)  
- for espag Atrium Alu-HS 200 (Hautau)

OBRADA ZA BRAVU Atrium Alu-HS 300 (Hautau)

-obrada na glodalici vretenastim glodalom  
za krilo FT-1120F

PROCESSING FOR ESPAG Atrium Alu-HS 300 (Hautau)

-processing on mill machine with end mill  
for sash FT-1120F

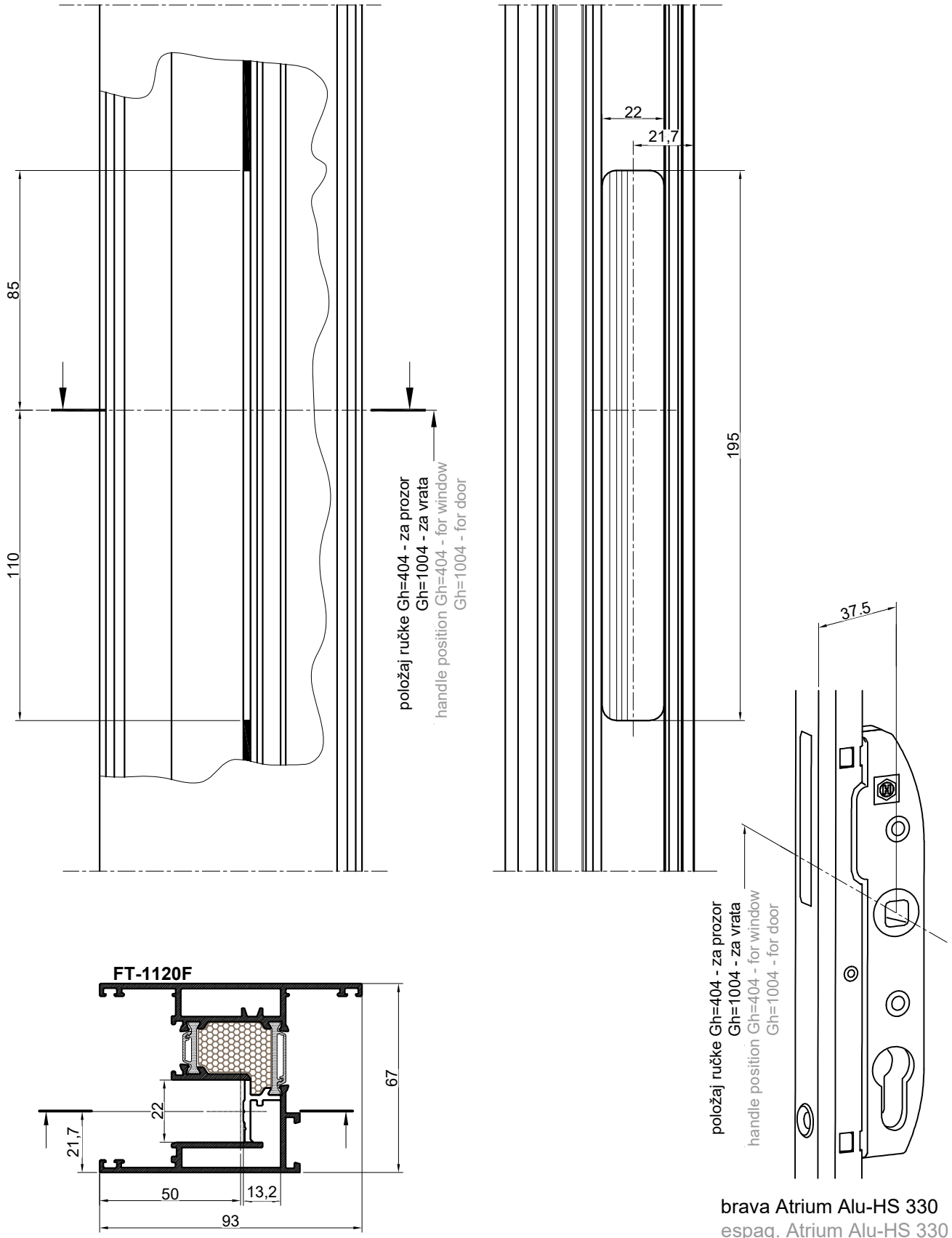

brava Atrium Alu-HS 330  
espag. Atrium Alu-HS 330

OBRADA PROFILA FT-1120F ZA RUČKU 108.006, Hautau, za HS 300  
PROCESSING PROFILE FT-1120F FOR HANDLE 108.006, Hautau, za HS 300

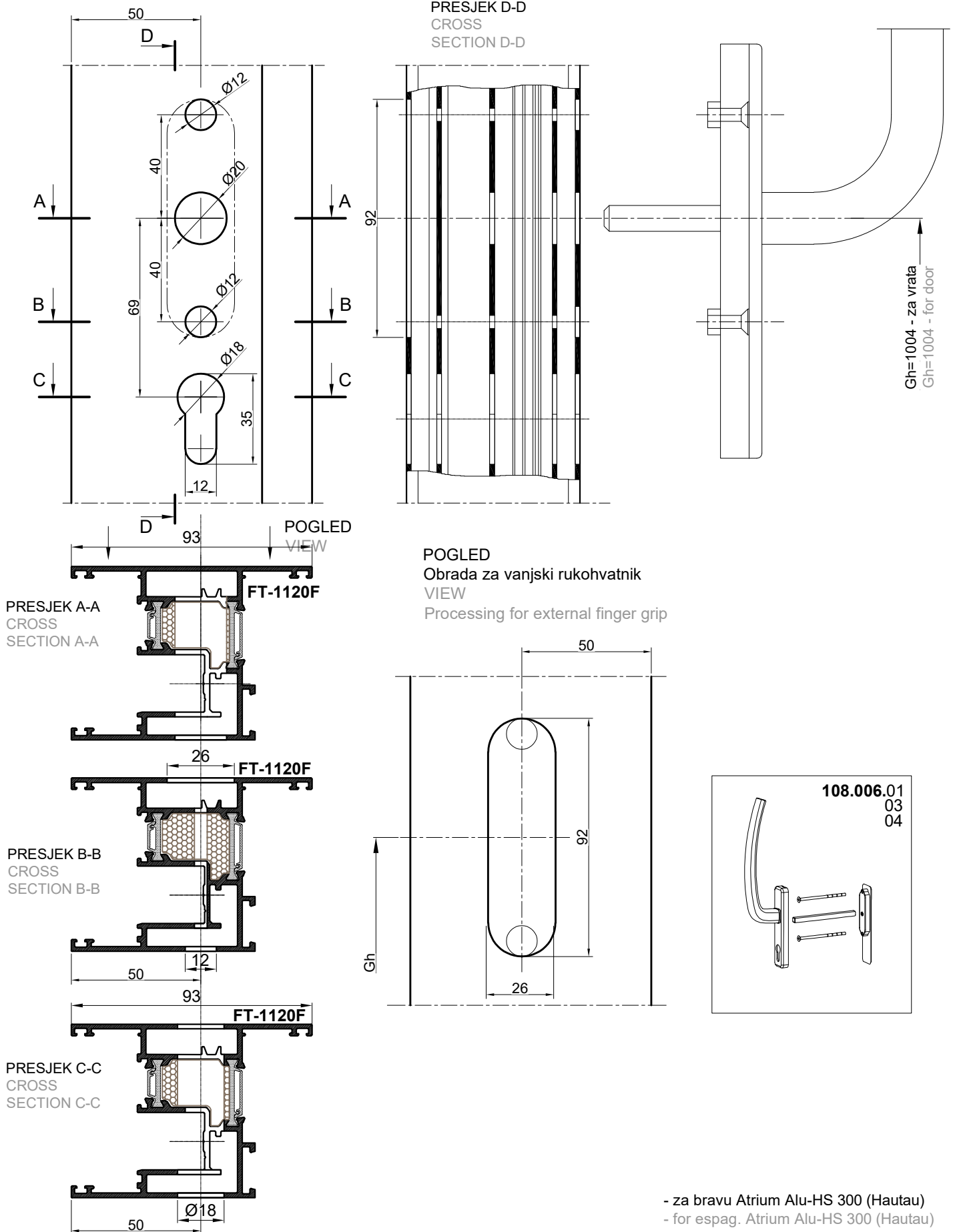

MONTAŽA OPRUGE ZA LAGANO POKRETANJE RUČKE PODIZNO KLIZNOG MEHANIZMA  
MOUNT SPRING ASSIST SYSTEM WITHIN THE ESPAG

Opruga za težine krila  
Accessories for sash weight  
≤ 200 kg

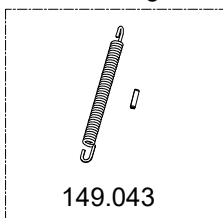

Opruga za težine krila  
Accessories for sash weight  
> 200 kg

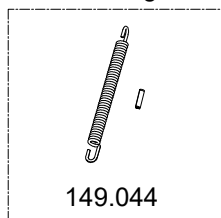

- A..... Postaviti bravu u dignuti položaj (otključano) (A.1/A.2).
  - B..... Postaviti zatik u određeni položaj na bravi (već postoji rupa na bravi)
  - C..... Pozicija opruge na bravi
  - D..... Povuci kraj zatezne opruge preko zuba na bravi (pomoću odvijača) (D.1/D.2).
  - E..... Ispravno namontirana opruga
- A.....Bring espag into raised position (A.1/A.2).
  - B.....Drive in the dowel pin.
  - C.....Position tension spring within the espag.
  - D.....Pull the end of the tension spring over the tappet at the drive rod (by means of a screw driver) (D.1/D.2).
  - E..... Correct mounted spring assist system

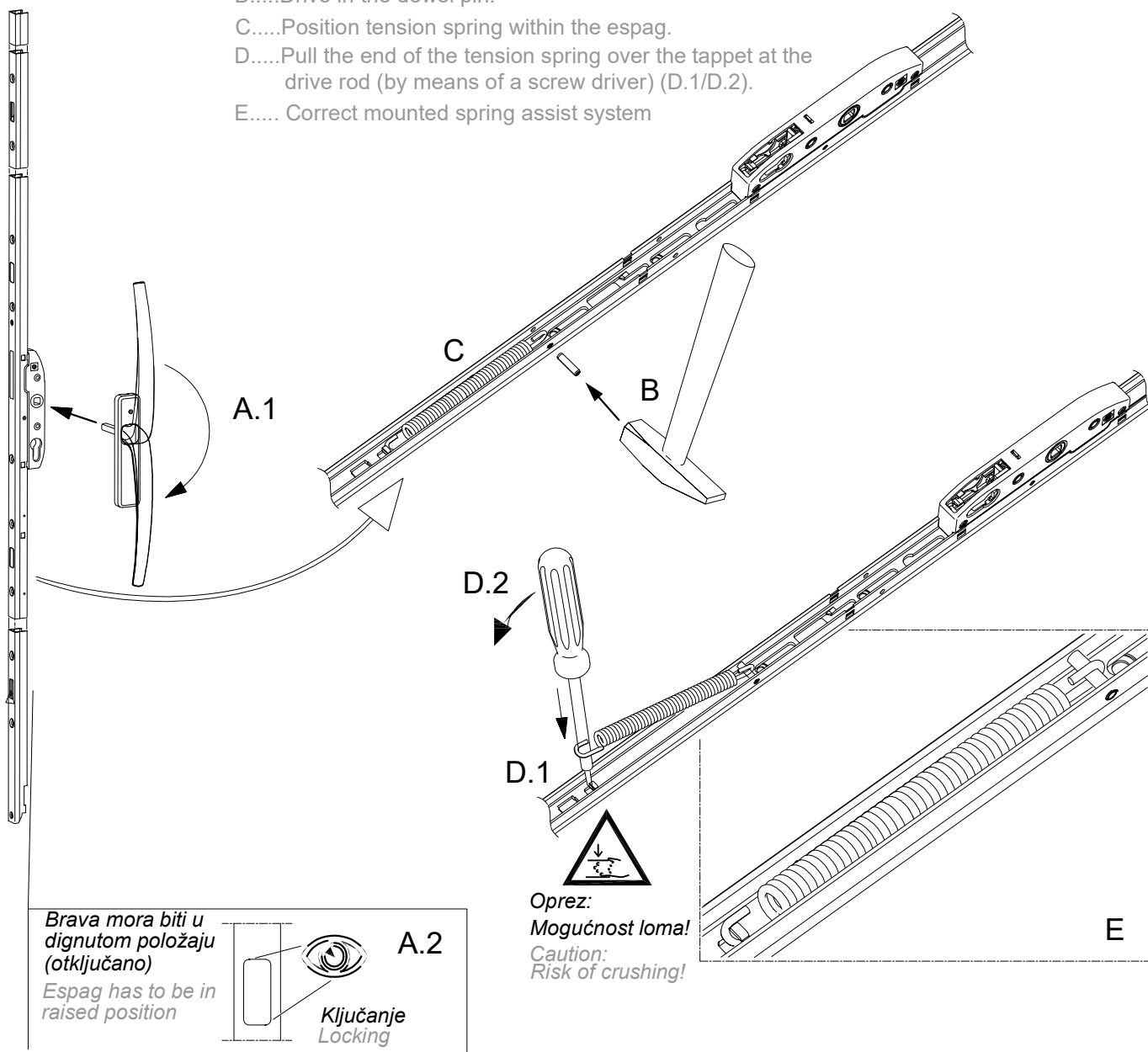

Brava mora biti u dignutom položaju (otključano)  
Espag has to be in raised position

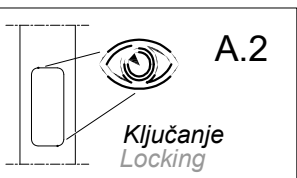

Opres:  
Mogućnost loma!  
Caution:  
Risk of crushing!

Izrezivanje termo štapića (poliamida) radi kompeziranja širenja profila  
Cutting thermo sticks (polyamide) to compensate for profile expansion

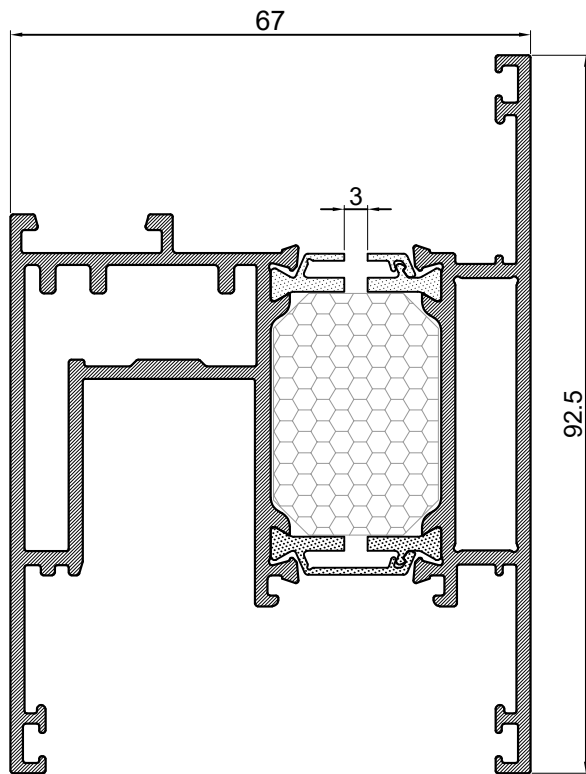

**FT-1022F**

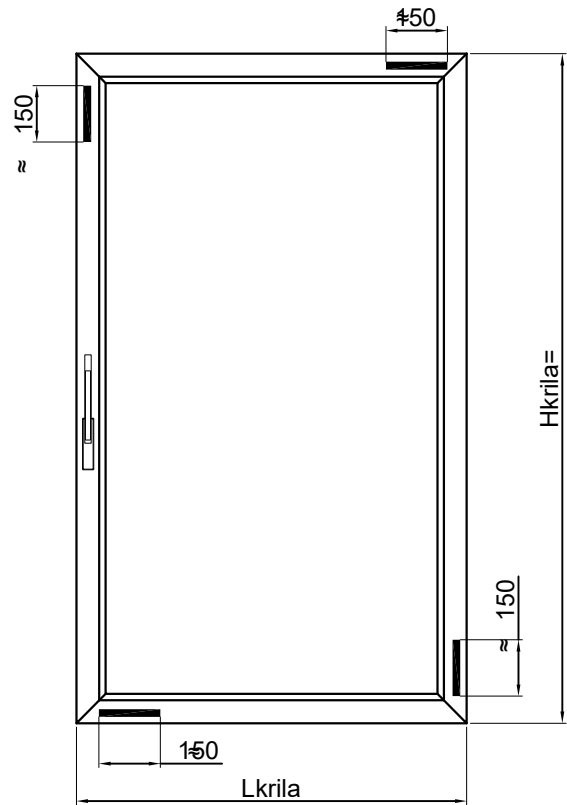

—  
Pozicija izrezivanja termo štapića (poliamida) na krilu  $\approx 150$  mm  
Pozicija izrezivanja termo štapića (poliamida) na krilu  $\approx 150$  mm

Izrezati termo štapiće (poliamide) cca. 150 mm  
Cut thermo sticks (polyamide) approximately 150 mm

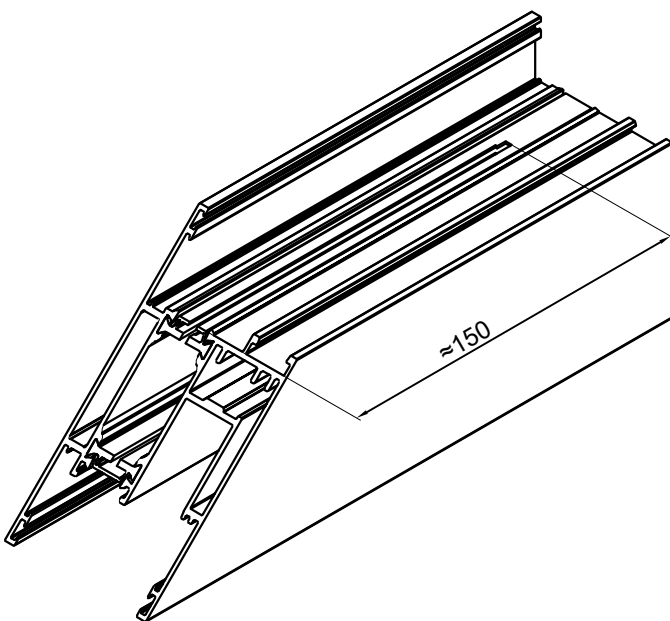

Zaljepiti jednostrano ljepljivu traku na mjestu reza termo štapića (poliamida)  
Stick one-sided adhesive tape on the cut of the thermo stick (polyamide)

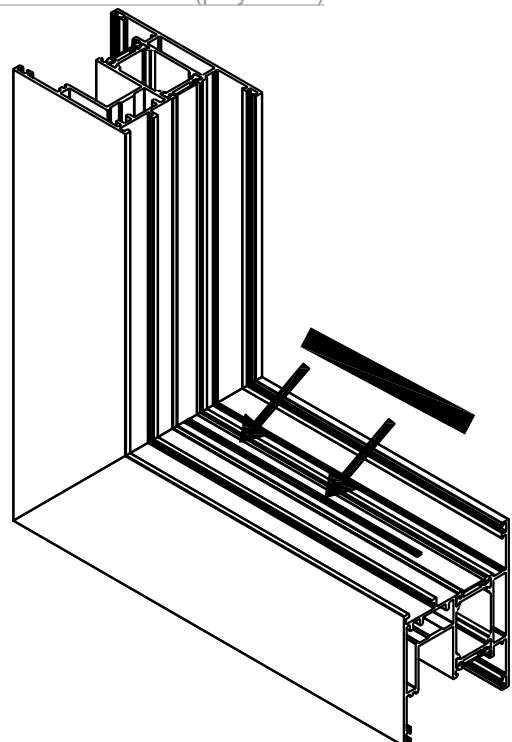

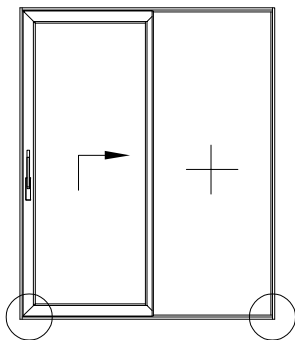

### MONTAŽA XPS BARIJERE U PROFILU PRAGA FT-1102F ZA ODVOD KAPLJEVINA INSTALLATION XPS BARRIER IN DOORSTEP PROFILE FT-1102F FOR WATER DRAINAGE

1. Po unutarnjem obodu vanjske komore bez prekida primjeniti neutralno silikonsko lijepilo (npr. Teroson MS 939)  
Apply neutral silicone adhesive to the inner circumference of the outer chamber without interruption (eg. Teroson MS 939)
2. U komore umetnuti umetke (340.454 i 340.455)  
In chamber insert (340.358)
3. Spojiti profile i ujedno pozicionirati umetak (340.454 i 340.455) na željeno mjesto  
Connect the profiles and also position insert (340.454 i 340.455) at the desired position

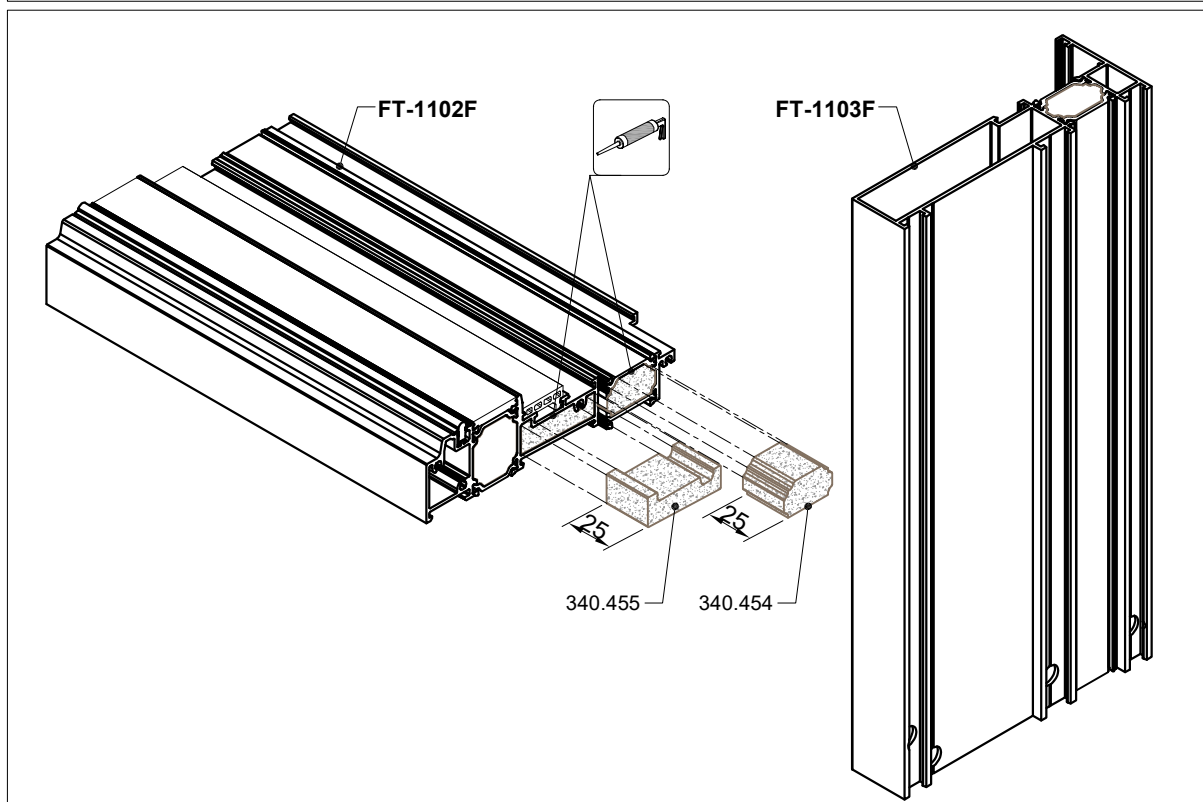
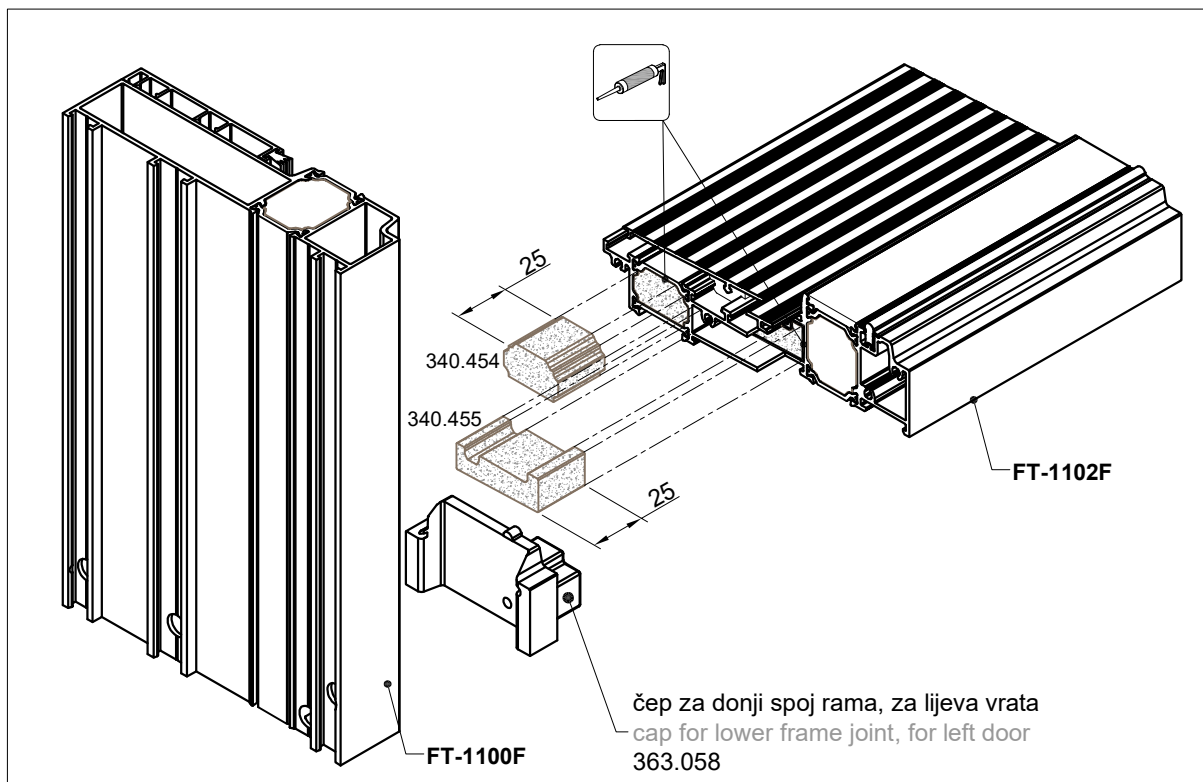

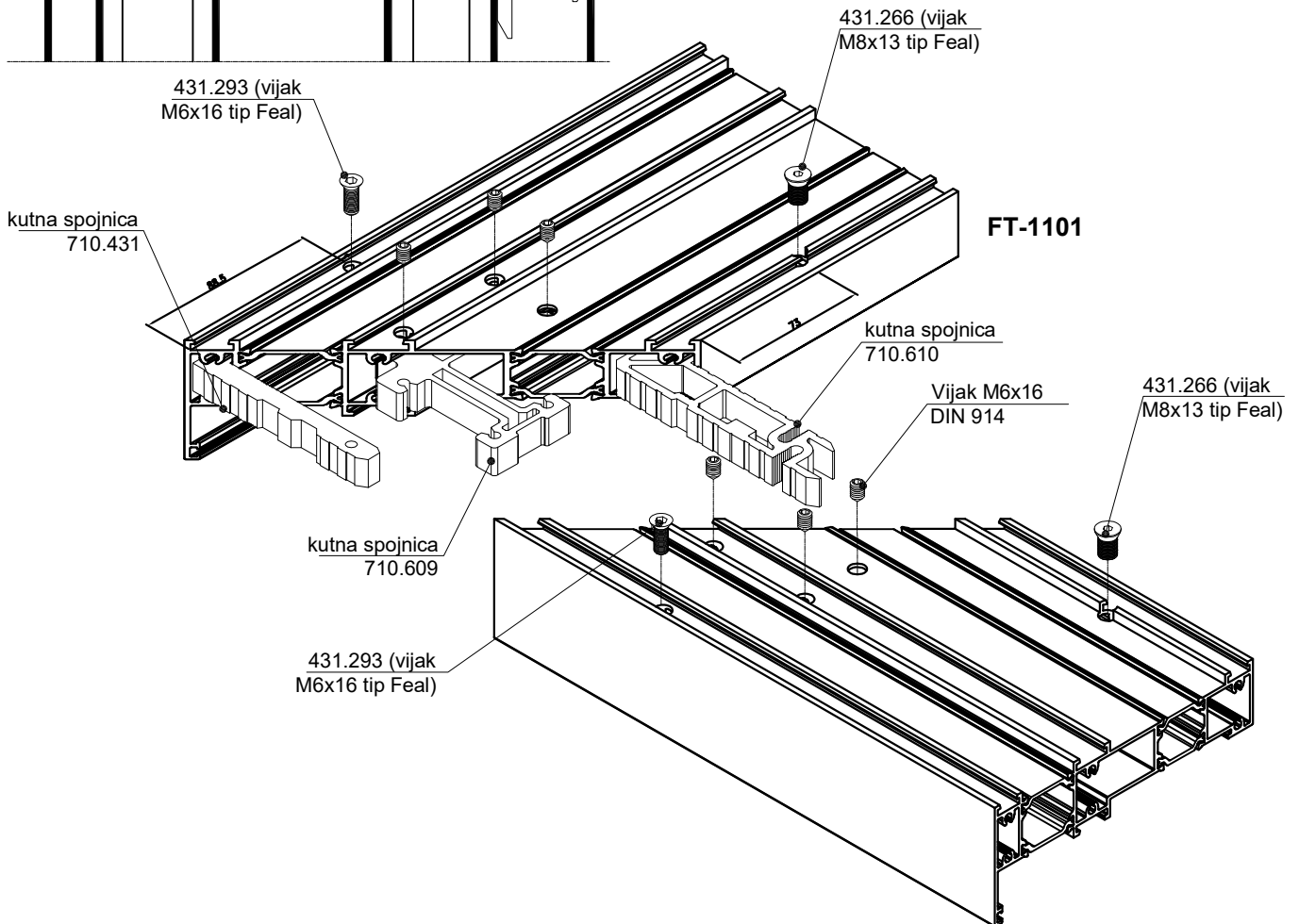
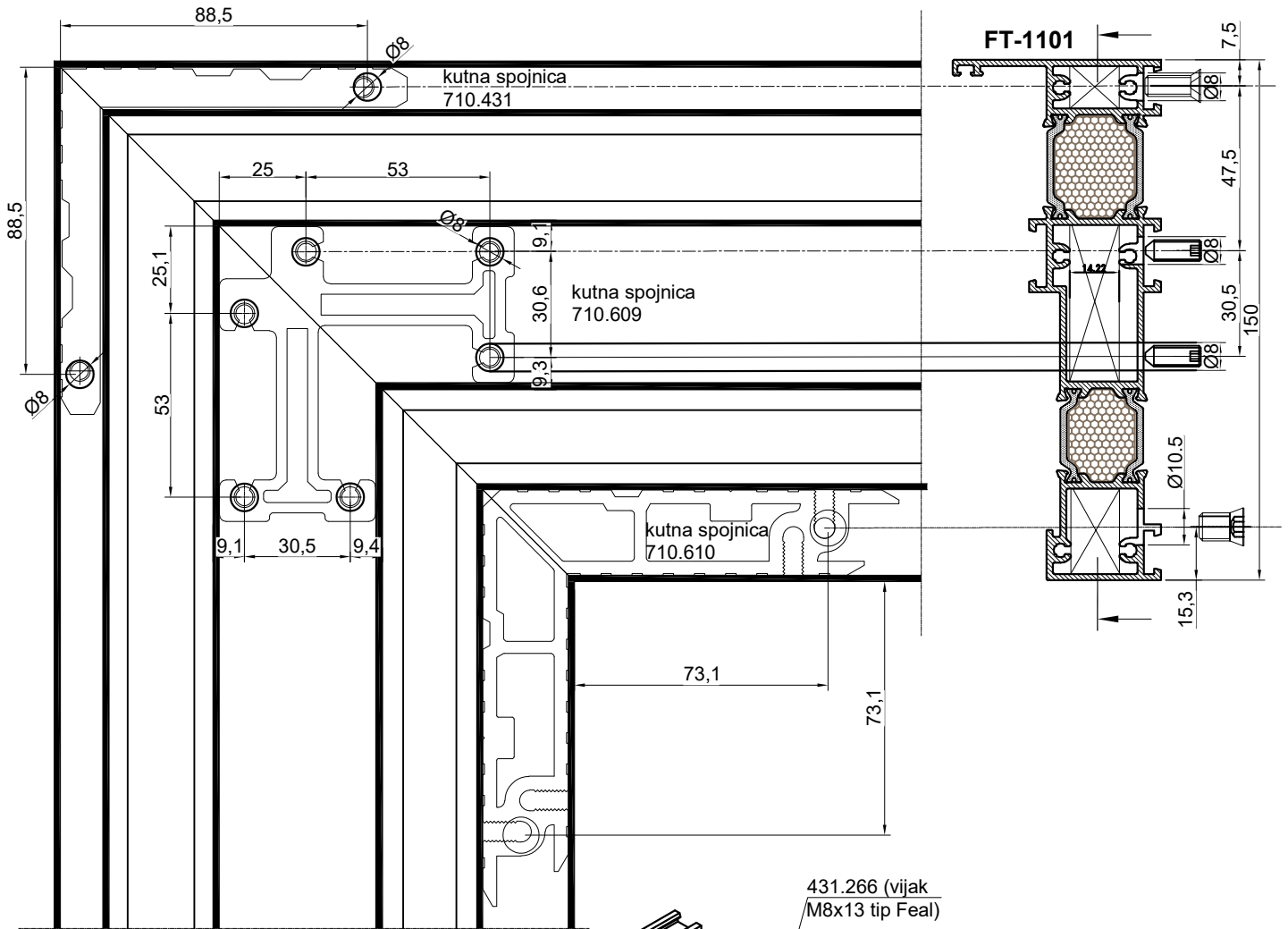

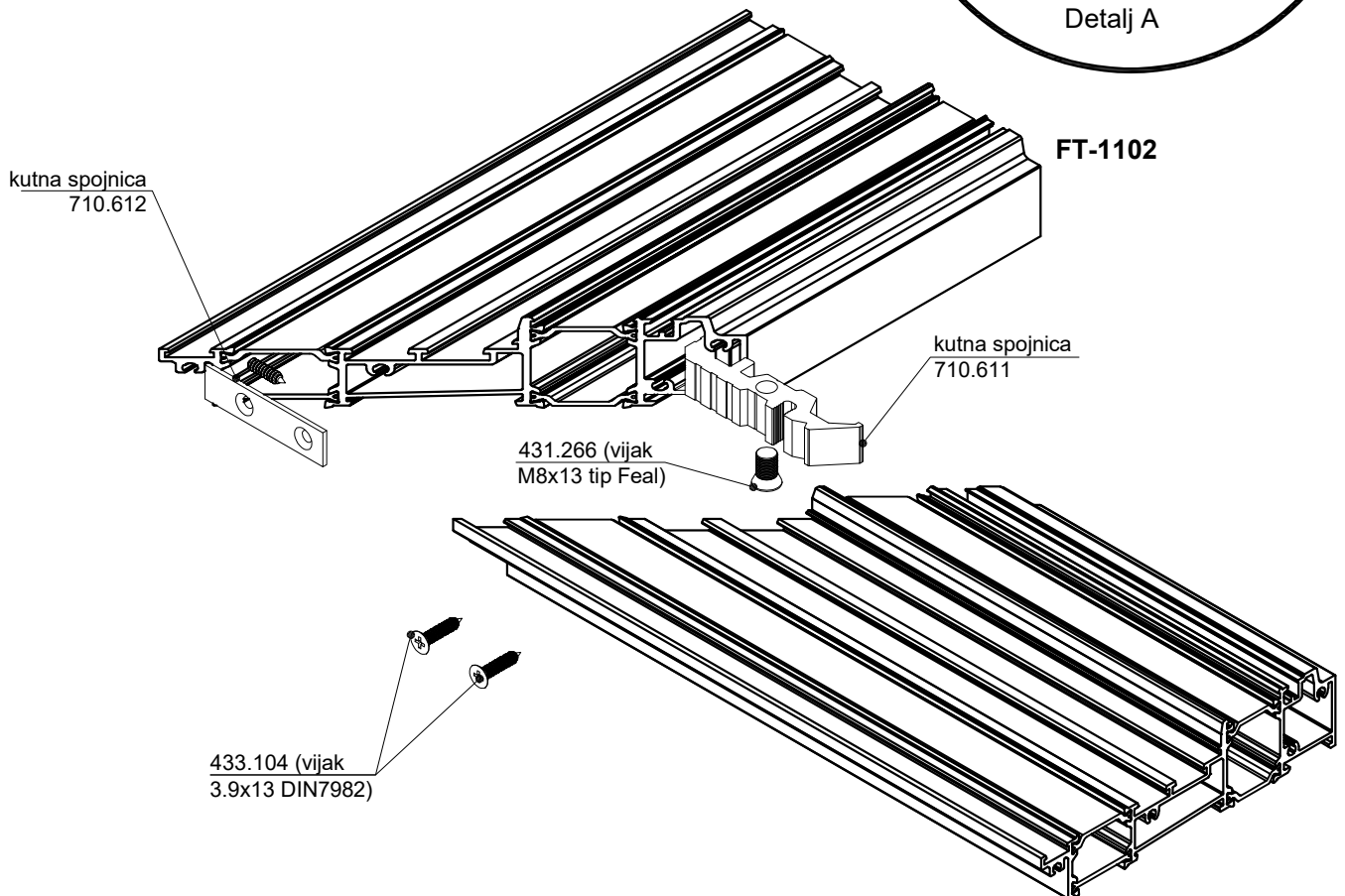
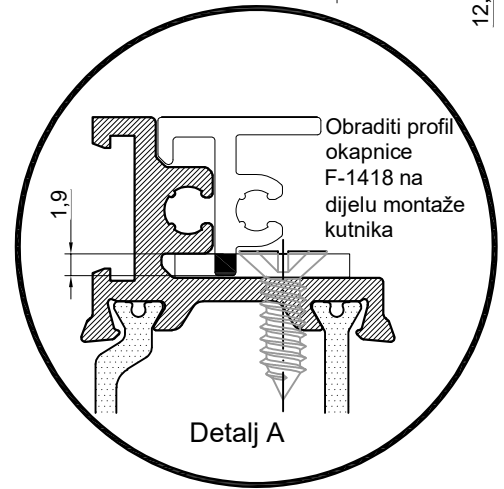
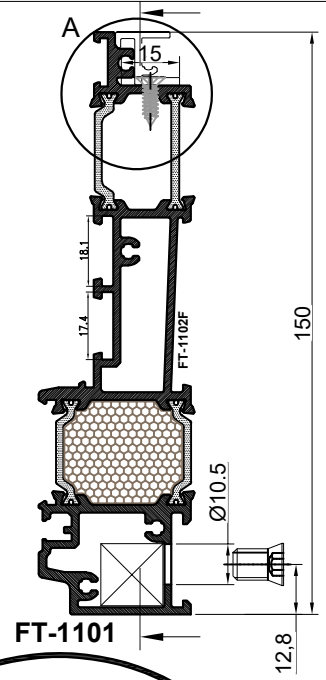
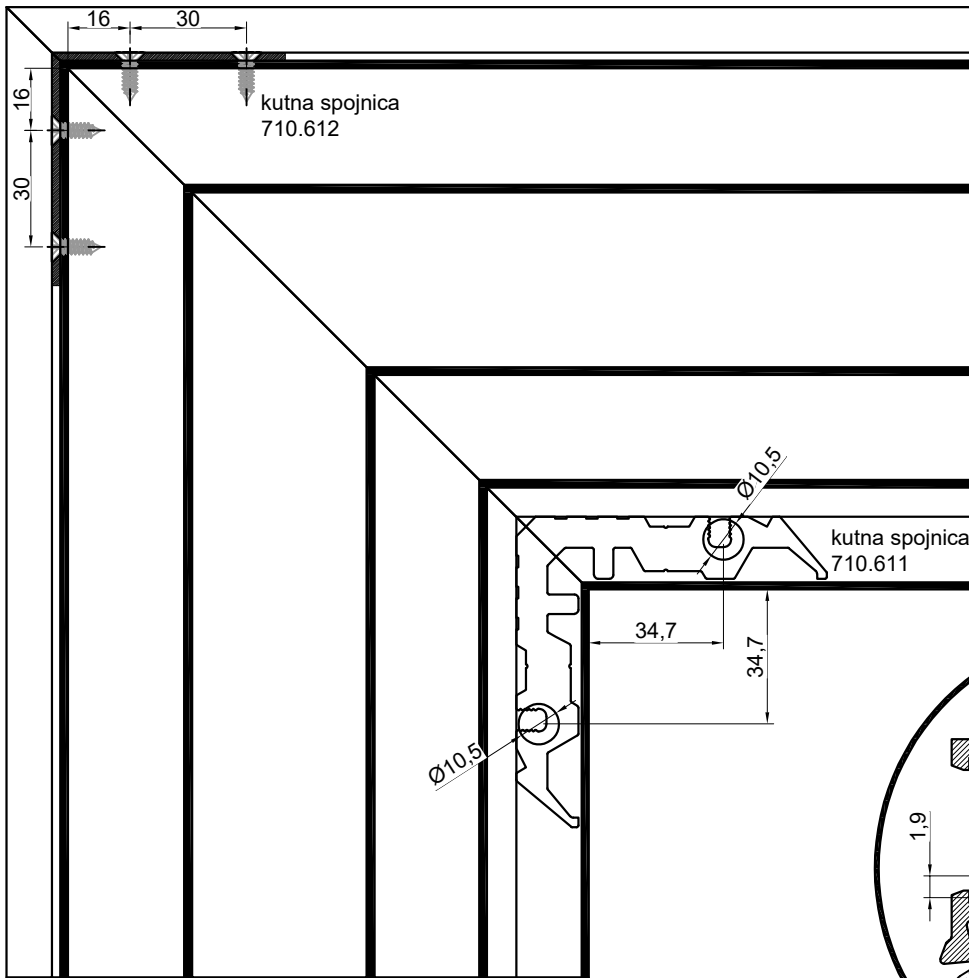



Obrada i montaža (Termo 150 plus)  
ravno pilanje rama  
Processing and montage  
straight frame cutting  
(Termo 150 plus)

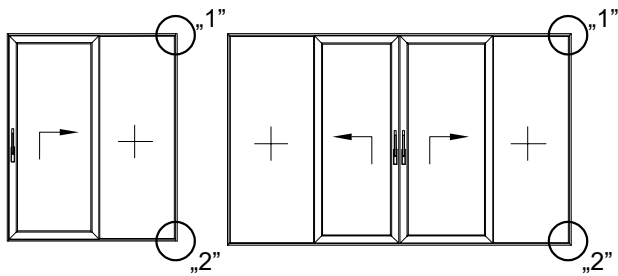

### OBRADA I SPAJANJE OKVIRA VRATA

#### PROCESSING AND MOUNTING DOOR FRAME

433.036  
vijci 4.2x45 DIN 7981  
screws 4.2x45 DIN 7981

-obrada rupa na profilu FT-1103F  
-processing holes on profile FT-1103F

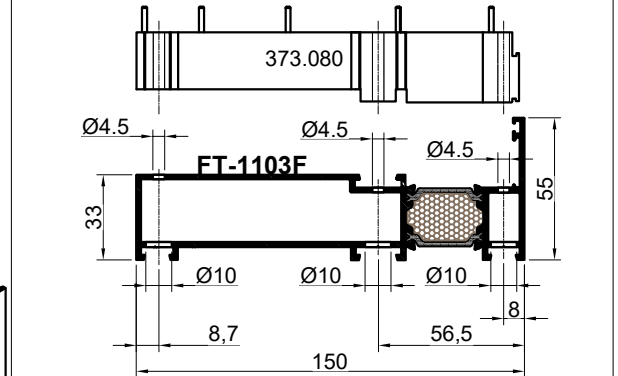
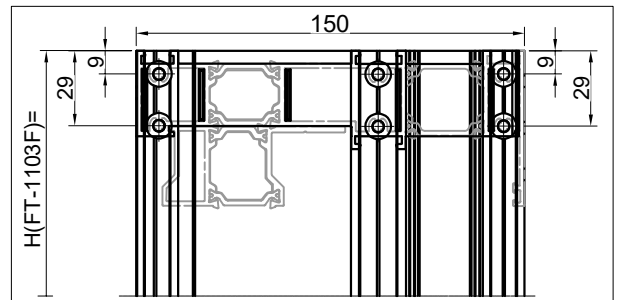
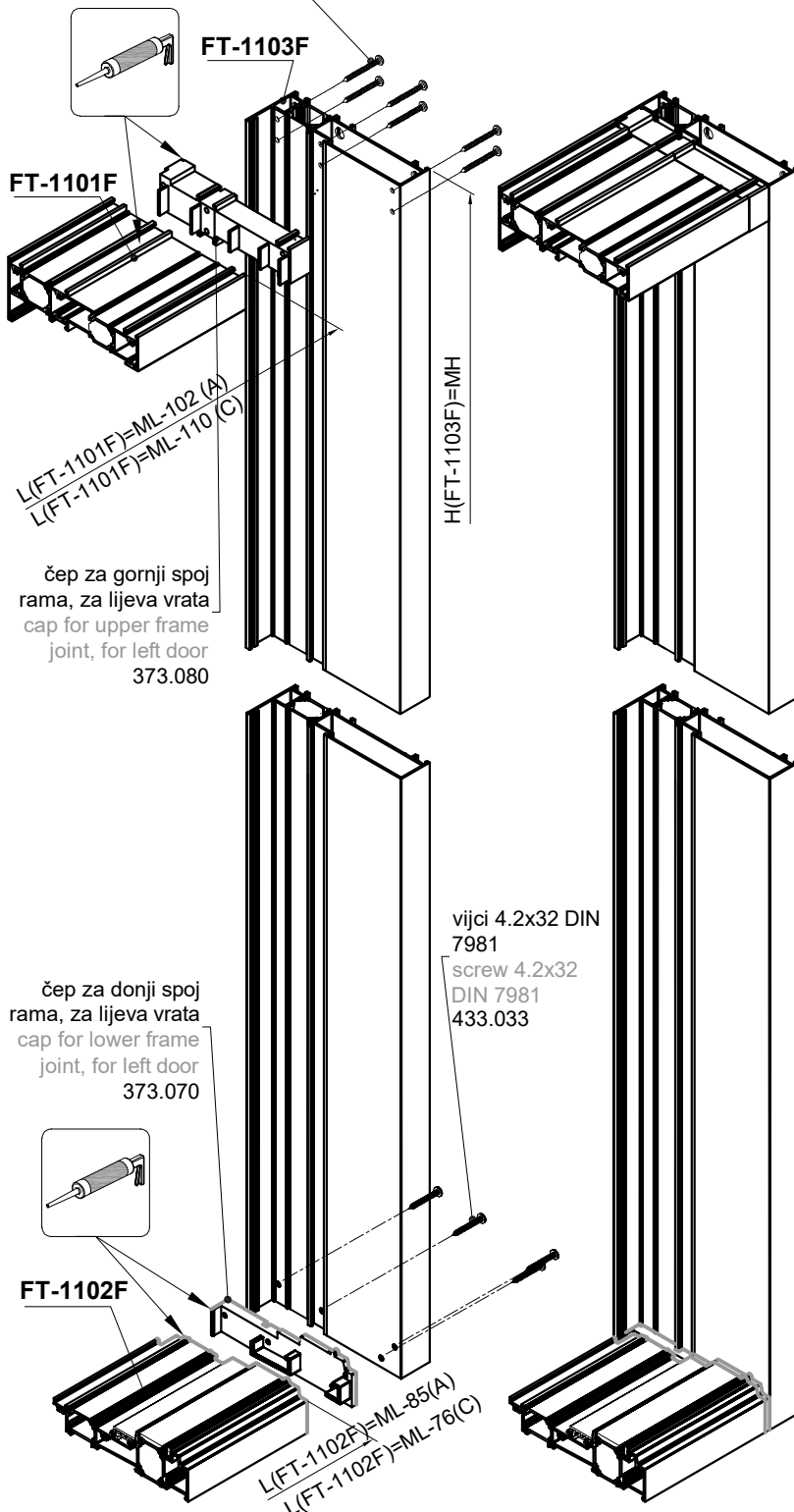

Obrada profila FT-1103F  
Processing profile FT-1103F

-profili okomice i vodoravnice okvira rama se spajaju pod 90°, vijcima 4.2x45 (DIN 7981)  
-mjera pilanja vodoravnog profila  
L (FT-1101F)=ML-102-gornji horizontalni profil  
L (FT-1102F)=ML-85-donji horizontalni profil-prag

Shema A



Shema C



L (FT-1101F)=ML-110-gornji horizontalni profil  
L (FT-1102F)=ML-76-donji horizontalni profil-prag  
-mjera pilanja okomitog profila H (FT-1103F)=MH  
-the vert.frame profile and the horiz frame profile are connected under 90°, with screws 4.2x32 (DIN 7981) with screws 4.2x45 (DIN 7981)  
-cutting profile length  
L (FT-1101F)=ML-102-upper horizontal profile  
L (FT-1102F)=ML-85-lower horizontal profile-treshold  
L (FT-1101F)=ML-110-upper horizontal profile  
L (FT-1102F)=ML-76-lower horizontal profile-treshold  
-cutting length of vert. frame profile H(FT-1103F)=MH

Scheme A



Scheme C



Obrada profila FT-1103F  
Profile processing FT-1103F

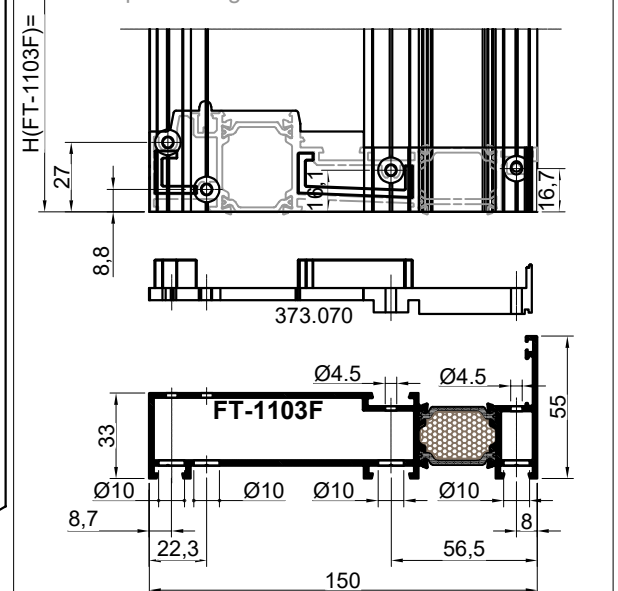

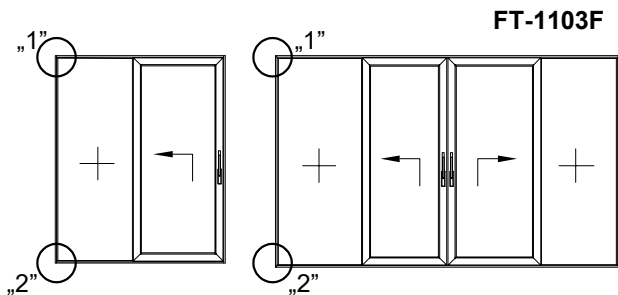

### OBRADA I SPAJANJE OKVIRA VRATA PROCESSING AND MOUNTING DOOR FRAME

- obrada rupa na profilu FT-1103F
- processing holes on profile FT-1103F

vijci 4.2x45 DIN 7981  
screws 4.2x45 DIN 7981  
433.036

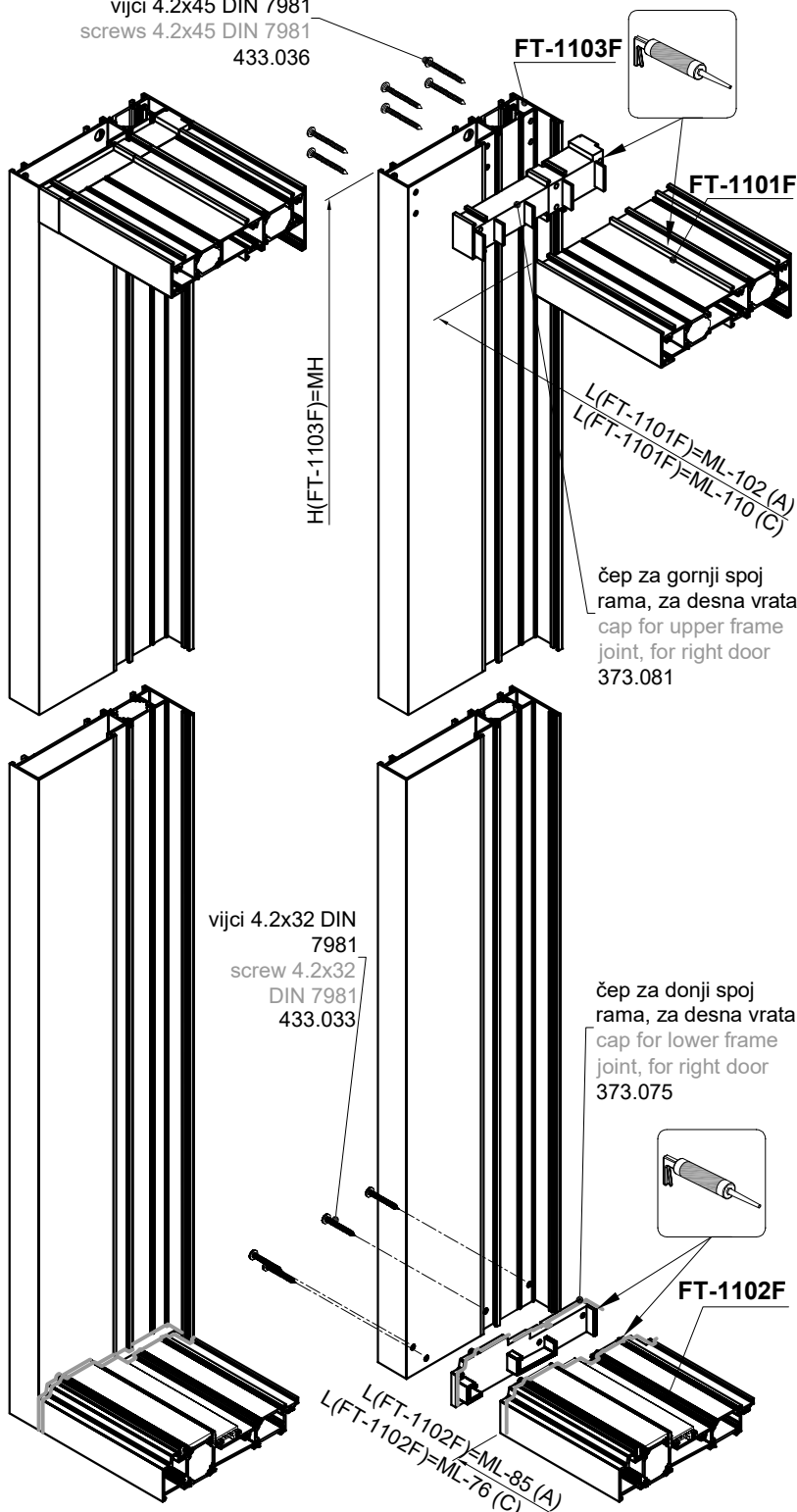

vijci 4.2x32 DIN 7981  
screw 4.2x32 DIN 7981  
433.033

čep za donji spoj rama, za desna vrata  
cap for lower frame joint, for right door  
373.075

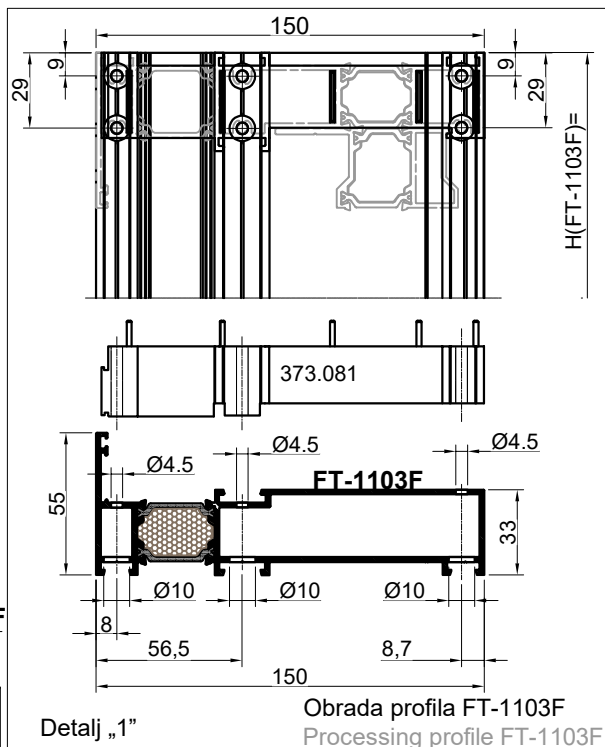

Detalj „1”

Obrada profila FT-1103F  
Profile processing FT-1103F

- profili okomice i vodoravnice okvira rama se spajaju pod 90°, vijcima 4.2x45 (DIN 7981)
- vijcima 4.2x32 (DIN 7981)

- mjera pilanja vodoravnog profila  
L (FT-1101F)=ML-102-gornji horizontalni profil  
L (FT-1102F)=ML-85-donji horizontalni profil-prag

Shema A



Shema C



- L (FT-1101F)=ML-110-gornji horizontalni profil  
L (FT-1102F)=ML-76-donji horizontalni profil-prag

- mjera pilanja okomitog profila H (FT-1103F)=MH
- the vert.frame profile and the horiz frame profile are connected under 90°, with screws 4.2x32 (DIN 7981) with screws 4.2x45 (DIN 7981)

Scheme A



Scheme C



- L (FT-1101F)=ML-110-upper horizontal profile  
L (FT-1102F)=ML-76-lower horizontal profile-treshold
- cutting length of vert. frame profile H(FT-1103F)=MH

Detalj „2” Obrada profila FT-1103F  
Profile processing FT-1103F

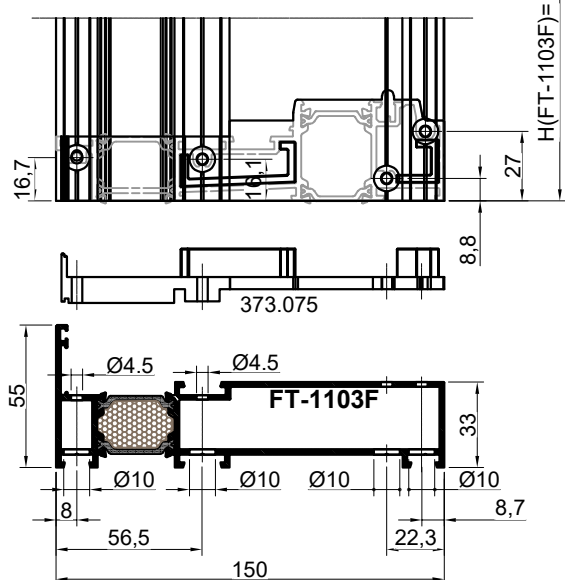

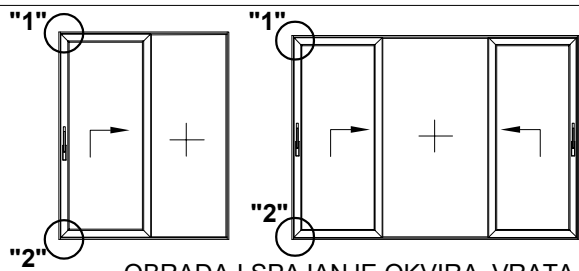

### OBRADA I SPAJANJE OKVIRA VRATA

-obrada rupa na profilu FT-1100F se radi šablonima tipa Feal

### PROCESSING AND MOUNTING DOOR FRAME

-processing holes on profile FT-1000F are made by Feal type templates

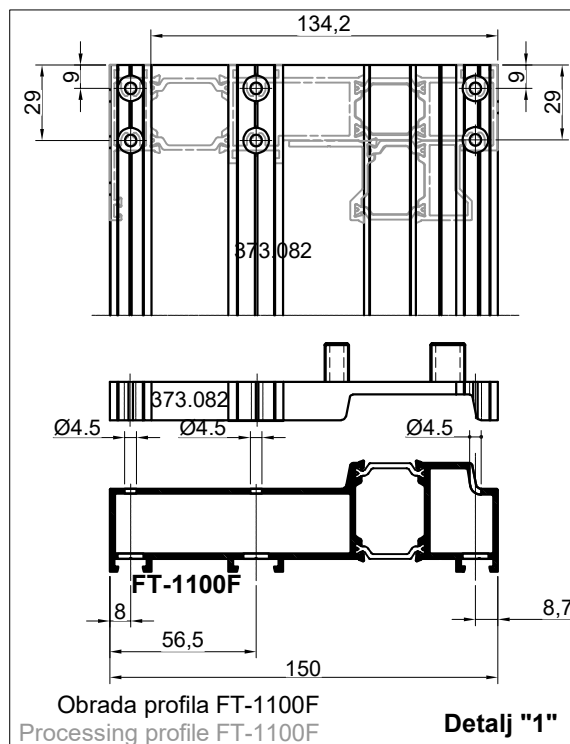

Obrada profila FT-1100F  
Processing profile FT-1100F

Detalj "1"

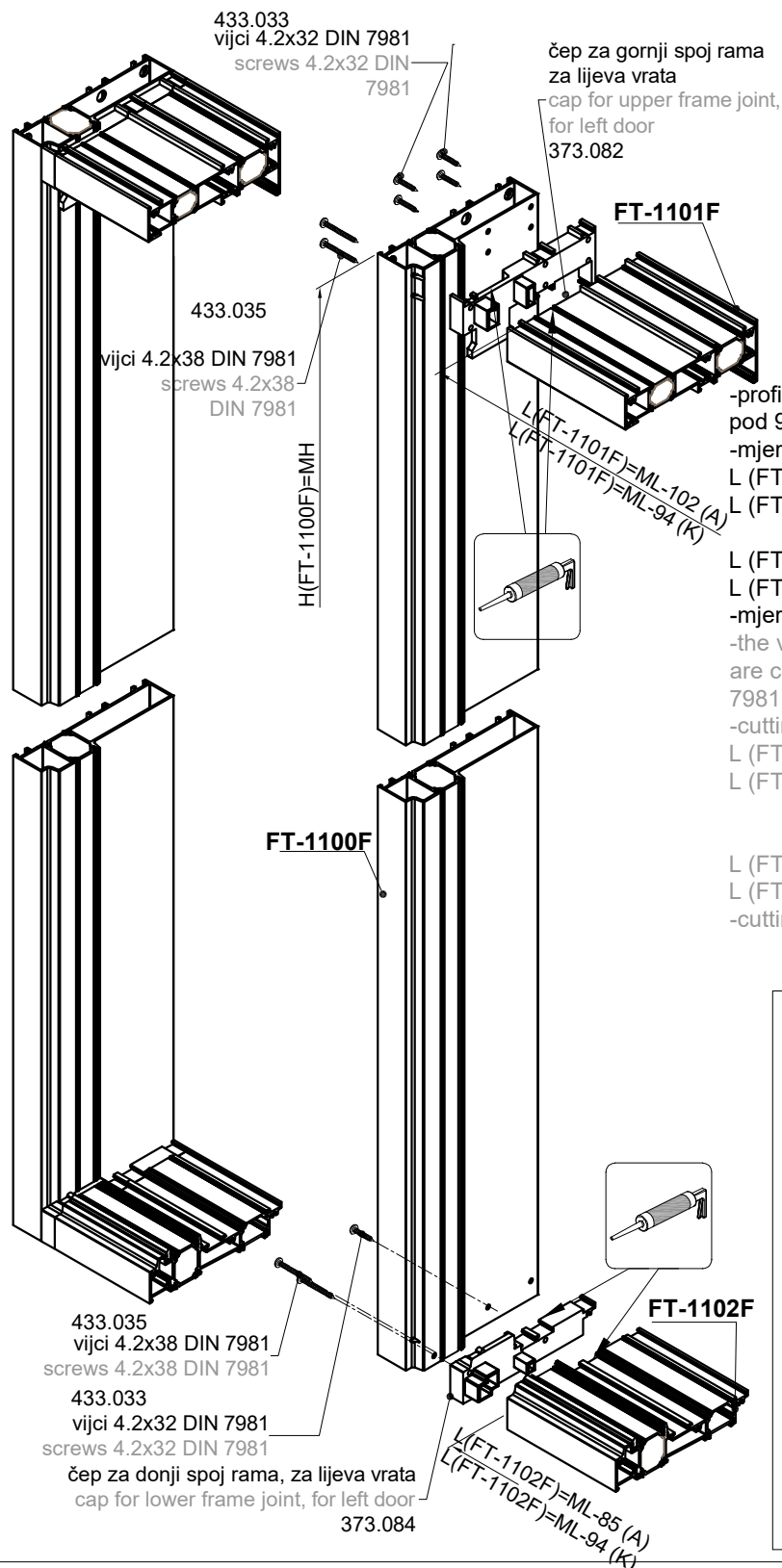

čep za gornji spoj rama  
za lijeva vrata  
cap for upper frame joint,  
for left door  
373.082

433.033  
vijci 4.2x32 DIN 7981  
screws 4.2x32 DIN  
7981

433.035  
vijci 4.2x38 DIN 7981  
screws 4.2x38  
DIN 7981

H(FT-1100F)=MH

FT-1101F  
L(FT-1101F)=ML-102 (A)  
L(FT-1101F)=ML-94 (K)

FT-1100F

FT-1102F  
L(FT-1102F)=ML-85 (A)  
L(FT-1102F)=ML-94 (K)

433.035  
vijci 4.2x38 DIN 7981  
screws 4.2x38 DIN 7981

433.033  
vijci 4.2x32 DIN 7981  
screws 4.2x32 DIN 7981

čep za donji spoj rama, za lijeva vrata  
cap for lower frame joint, for left door  
373.084

-profili okomice i vodoravnice okvira rama se spajaju  
pod 90°, vijcima 4.2x32 (DIN 7981)

-mjera pilanja vodoravnog profila

L (FT-1101F)=ML-102-gornji horizontalni profil

L (FT-1102F)=ML-85-donji horizontalni profil-prag

L (FT-1101F)=ML-94 -gornji horizontalni profil

L (FT-1102F)=ML-94-donji horizontalni profil-prag

-mjera pilanja okomiog profila H (FT-1100F)=MH

-the vert. frame profile and the horizontal frame profile  
are connected under 90°, with screws 4.2x32 (DIN  
7981)

-cutting profile length

L (FT-1101F)=ML-102-upper horizontal profile

L (FT-1102F)=ML-85-lower horizontal profile-treshold

L (FT-1101F)=ML-94-upper horizontal profile

L (FT-1102F)=ML-94-lower horizontal profile-treshold

-cutting length of vert frame profile H (FT-1100F)=MH

### Detalj "2"

Obrada profila FT-1100F

Processing profile FT-1100F

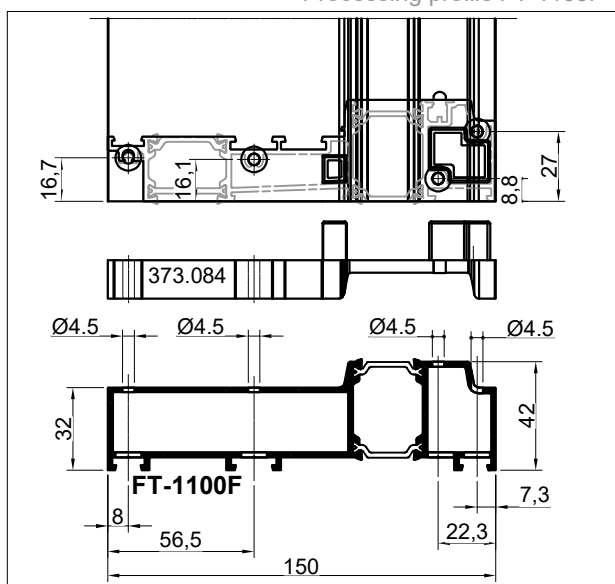

Shema A

Shema K

Scheme A

Scheme K

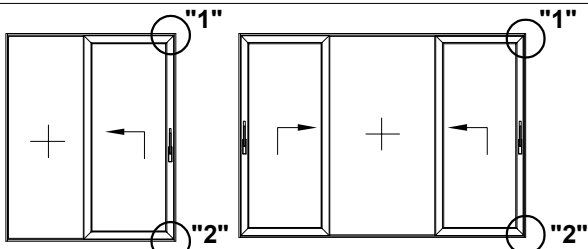

### OBRADA I SPAJANJE OKVIRA VRATA

-obrada rupa na profilu FT-1100F se radi šablonima tipa Feal

### PROCESSING AND MOUNTING DOOR FRAME

-processing holes on profile FT-1000F are made by Feal type templates

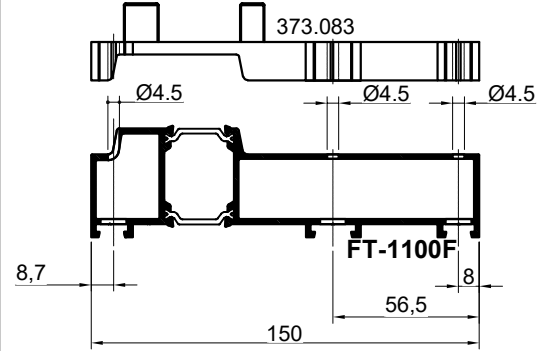
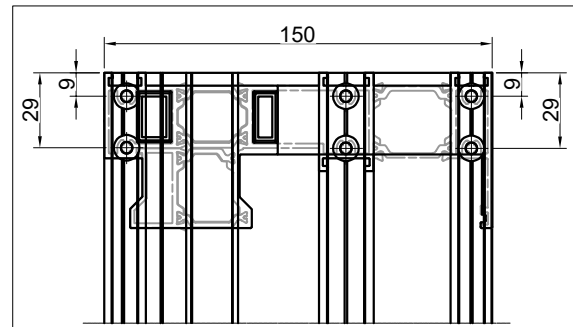
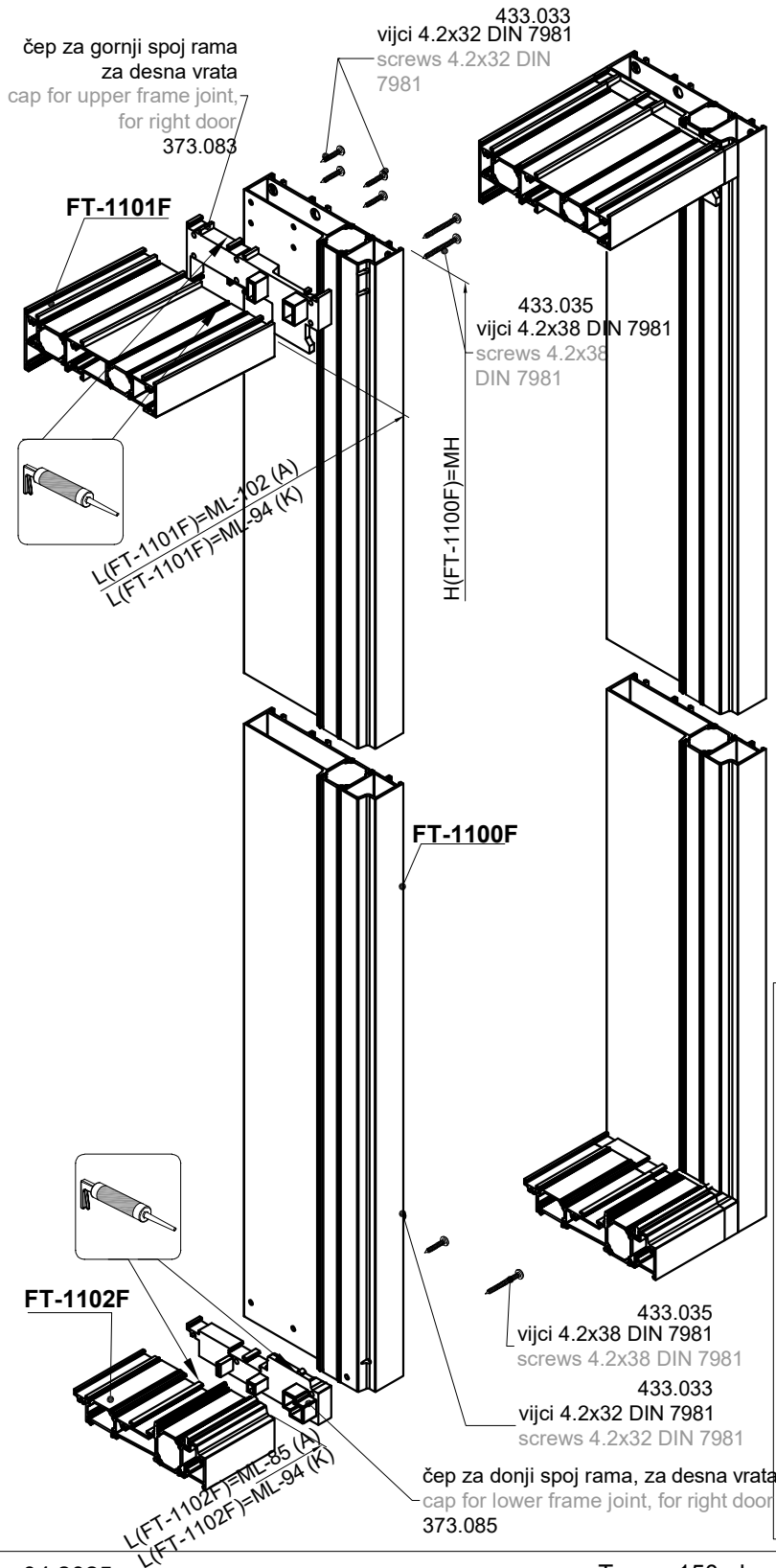

### Detalj "1"

Obrada profila FT-1100F  
Processing profile FT-1100F

-profili okomice i vodoravnice okvira rama se spajaju pod 90°, vijcima 4.2x32 (DIN 7981)

-mjera pilanja vodoravnog profila

L (FT-1101F)=ML-102

L (FT-1102F)=ML-85

Shema A



Shema K

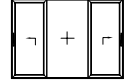

L (FT-1101F)=ML-94

L (FT-1102F)=ML-94

-mjera pilanja okomiog profila H (FT-1100F)=MH  
-the vert. frame profile and the horizontal frame profile are connected under 90°, with screws 4.2x32 (DIN 7981)

-cutting profile length

L (FT-1101F)=ML-102

L (FT-1102F)=ML-85

Shema A



Shema K

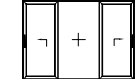

L (FT-1101F)=ML-94

L (FT-1102F)=ML-94

-cutting length of vert frame profile H (FT-1100F)=MH

Obrada profila FT-1100F

### Detalj "2"

Processing profile FT-1100F

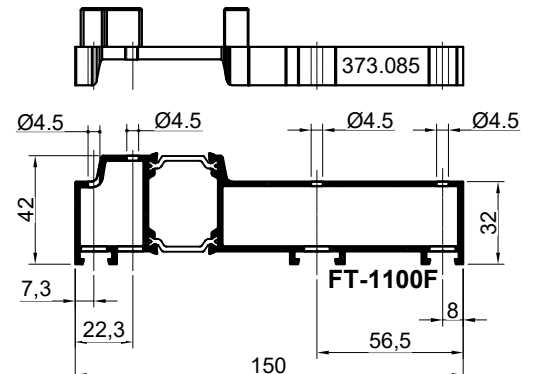
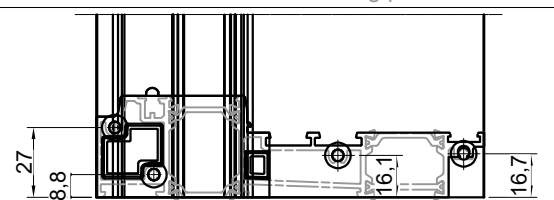

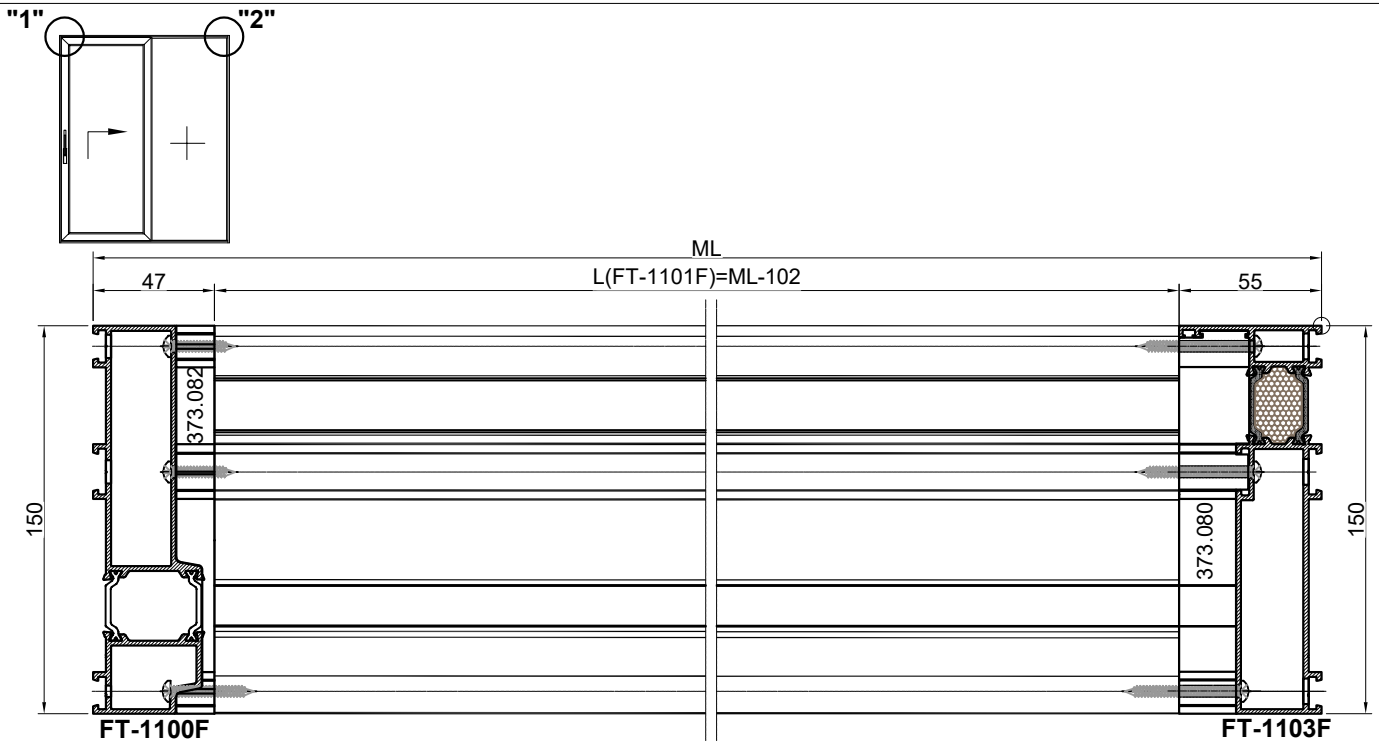

Obrada profila FT-1101F  
prema vertikalnom profilu rama FT-1100F  
Processing profile FT-1101F towards vert.  
frame profile FT-1100F

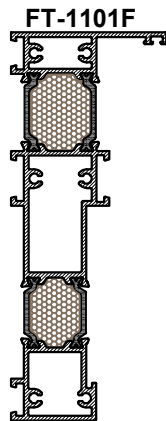
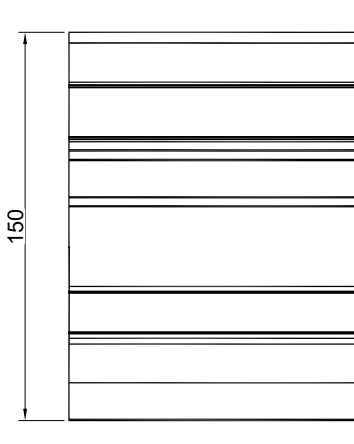

433.033  
(vijci 4.2x32 DIN 7981)  
(screws 4.2x32 DIN 7981)  
433.035  
(vijci 4.2x38 DIN 7981)  
(screws 4.2x38 DIN 7981)

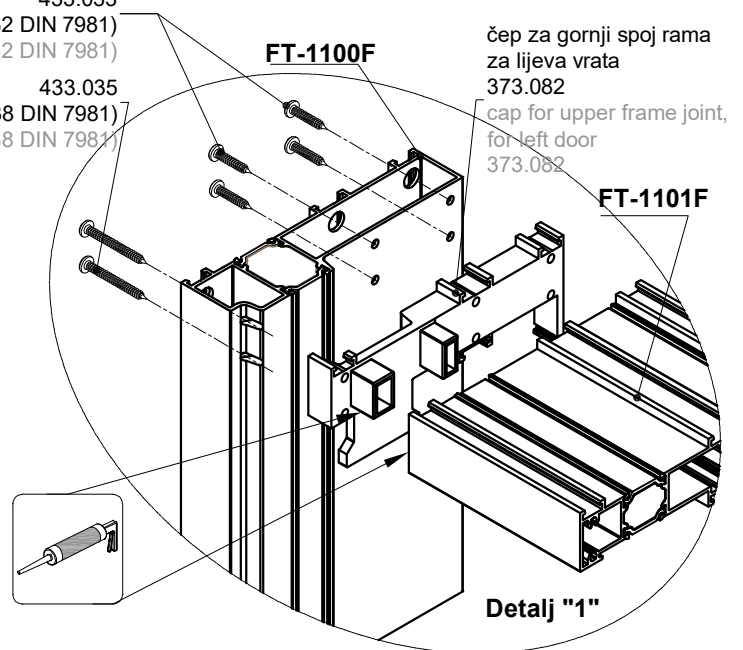

Detalj "1"

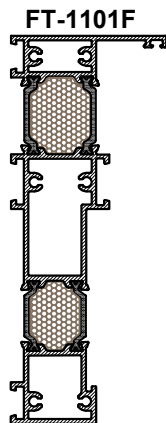
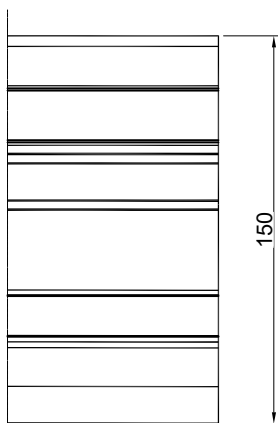

FT-1101F  
433.036  
vijci 4.2x45 DIN 7981  
screws 4.2x45 DIN 7981

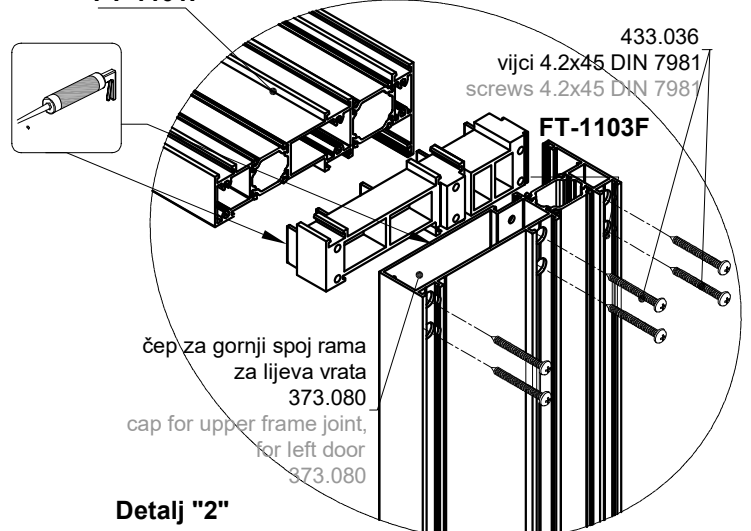

Detalj "2"

Obrada profila FT-1101F  
prema vertikalnom profilu rama FT-1103F  
Processing profile FT-1101F  
towards vert. frame profile FT-1103F

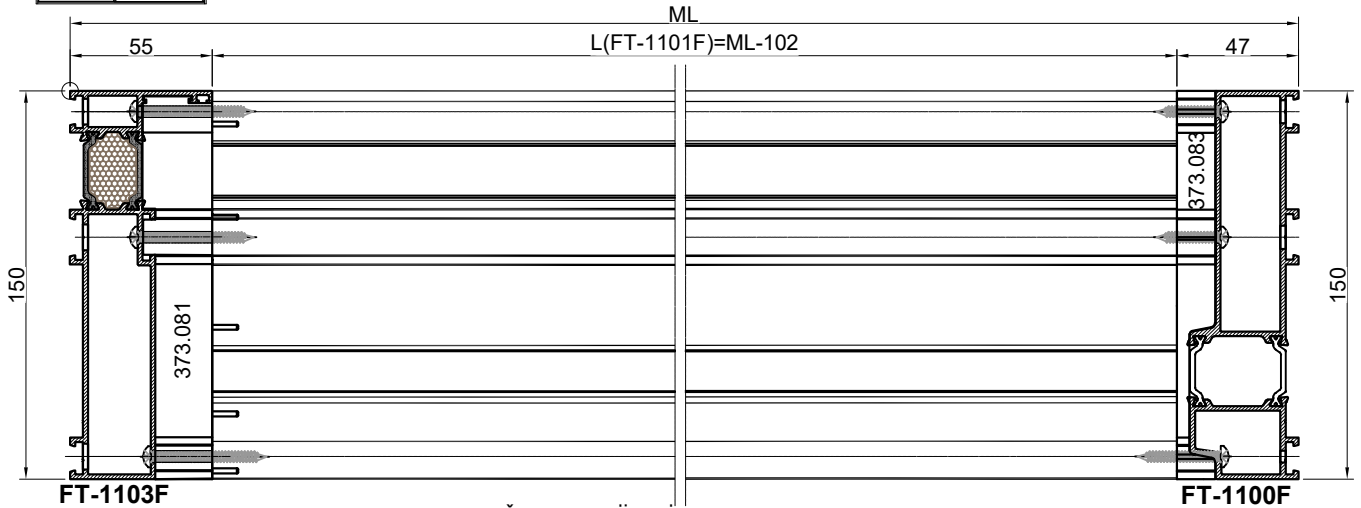
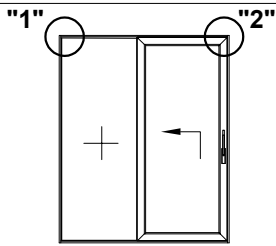

Obrada profila FT-1101F  
prema vertikalnom profilu rama FT-1100F  
Processing profile FT-1101F towards vert.  
frame profile FT-1100F

čep za gornji spoj rama  
za desna vrata  
373.083  
cap for upper frame joint,  
for right door  
373.083

433.033  
(vijci 4.2x32 DIN 7981)  
(screws 4.2x32 DIN 7981)  
433.035  
(vijci 4.2x38 DIN 7981)  
(screws 4.2x38 DIN 7981)

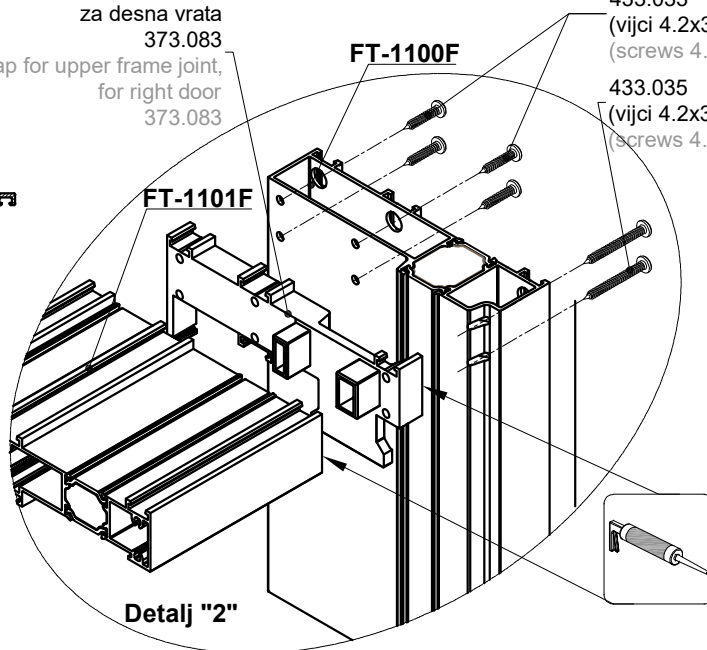
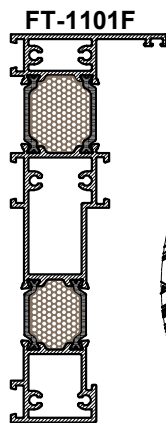
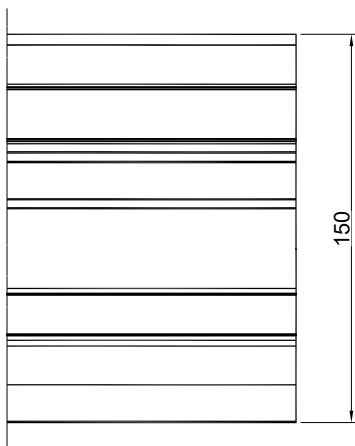

Detalj "2"

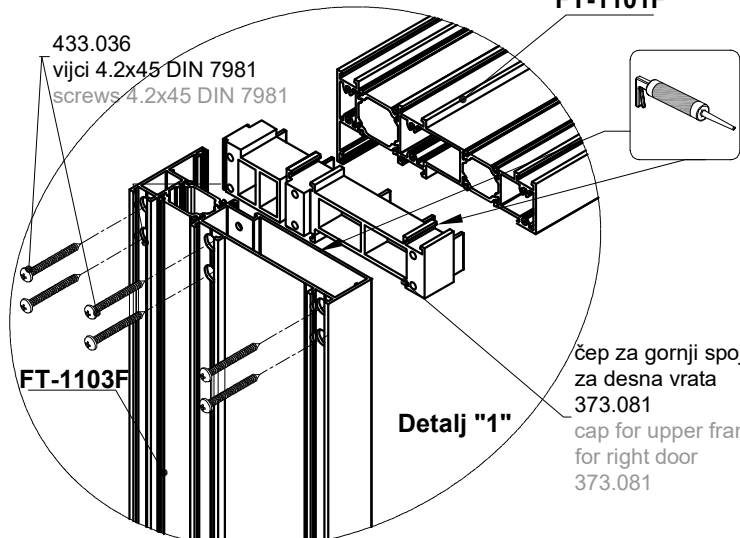
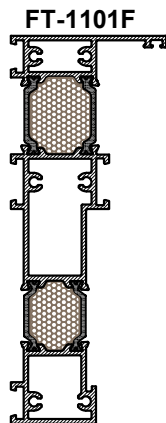
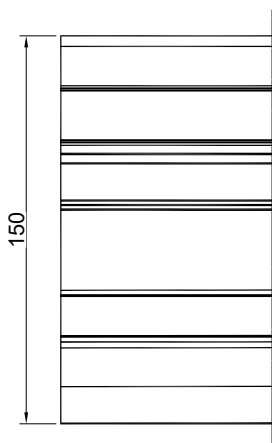

Detalj "1"

Obrada profila FT-1101F  
prema vertikalnom profilu rama FT-1103F  
Processing profile FT-1101F  
towards vert. frame profile FT-1103F

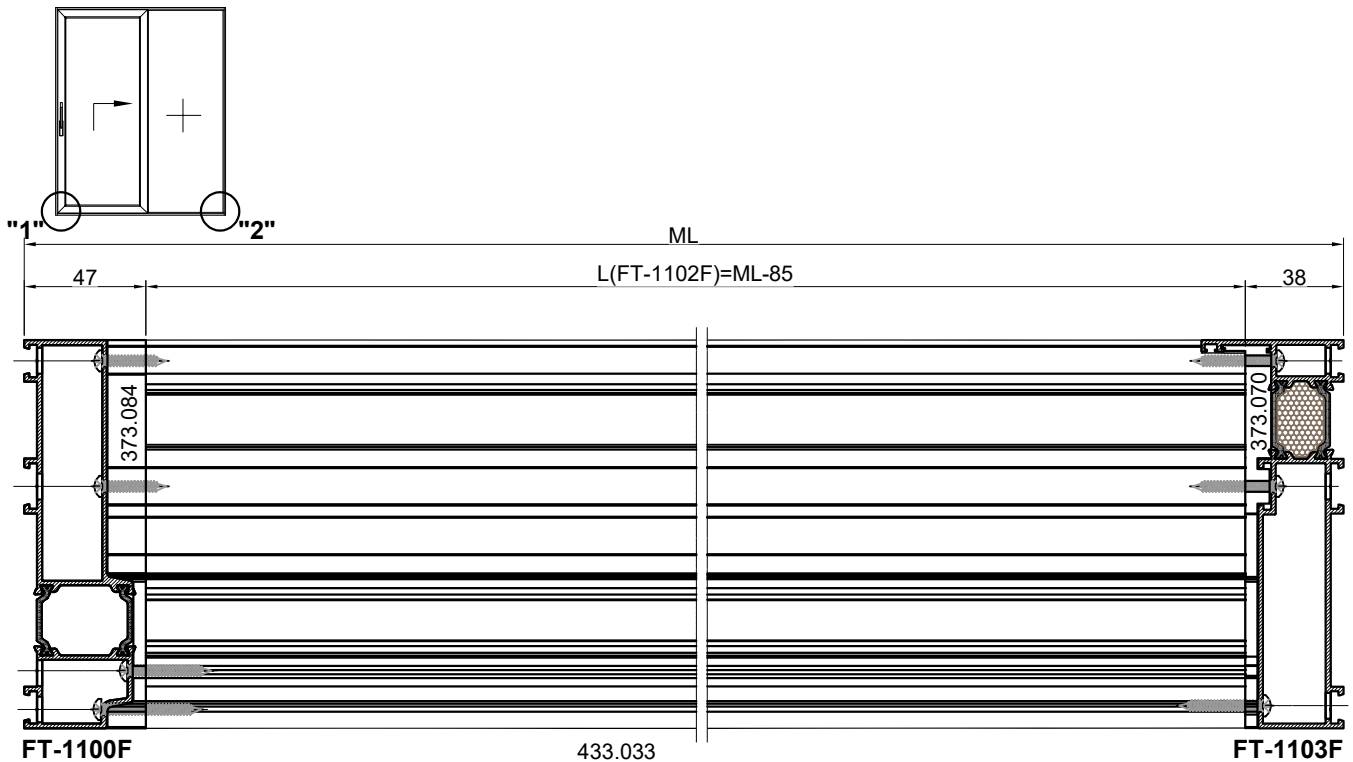

Obrada profila FT-1102F  
prema vertikalnom profilu rama FT-1100F  
Processing profile FT-1102F  
towards vert. frame profile FT-1100F

433.033  
(vijci 4.2x32 DIN 7981)  
(screws 4.2x32 DIN 7981)  
433.035  
(vijci 4.2x38 DIN 7981)  
(screws 4.2x38 DIN 7981)

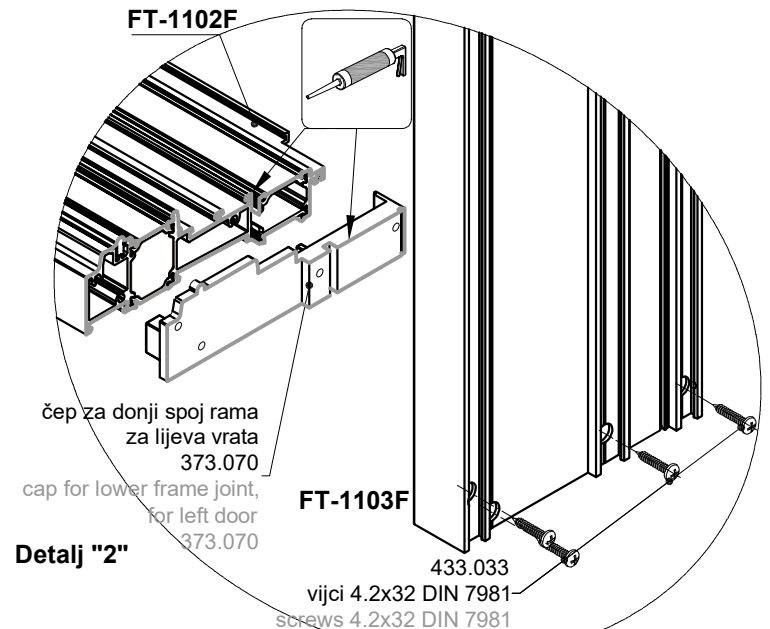
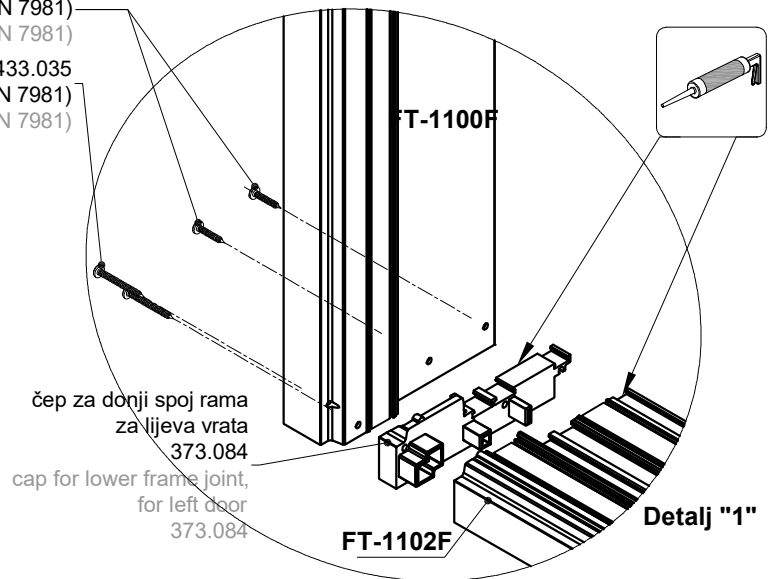
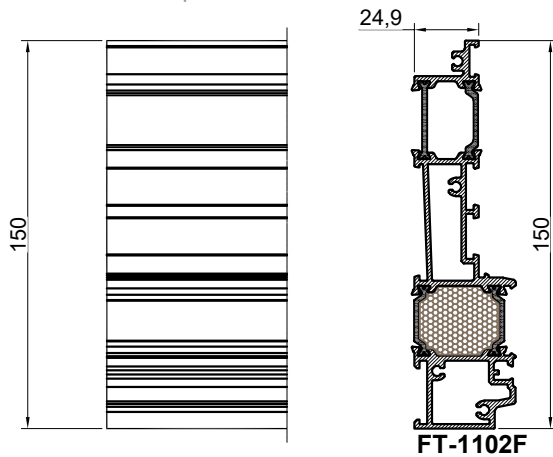

Obrada profila FT-1102F  
prema vertikalnom profilu rama FT-1103F  
Processing profile FT-1102F  
towards vert. frame profile FT-1103F

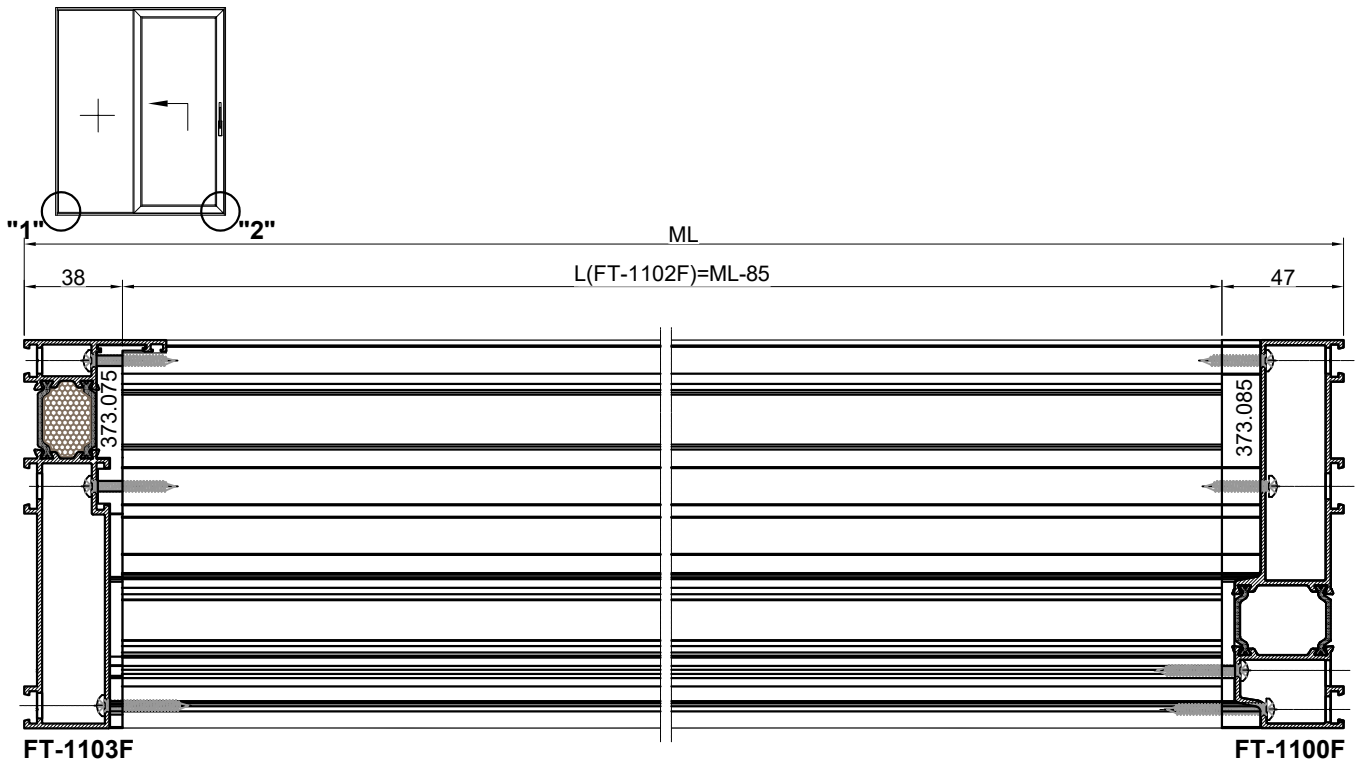

Obrada profila FT-1102F  
prema vertikalnom profilu rama FT-1100F  
Processing profile FT-1102F  
towards vert. frame profile FT-1100F

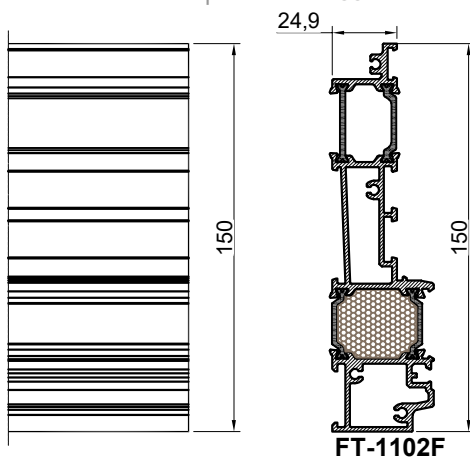

FT-1102F

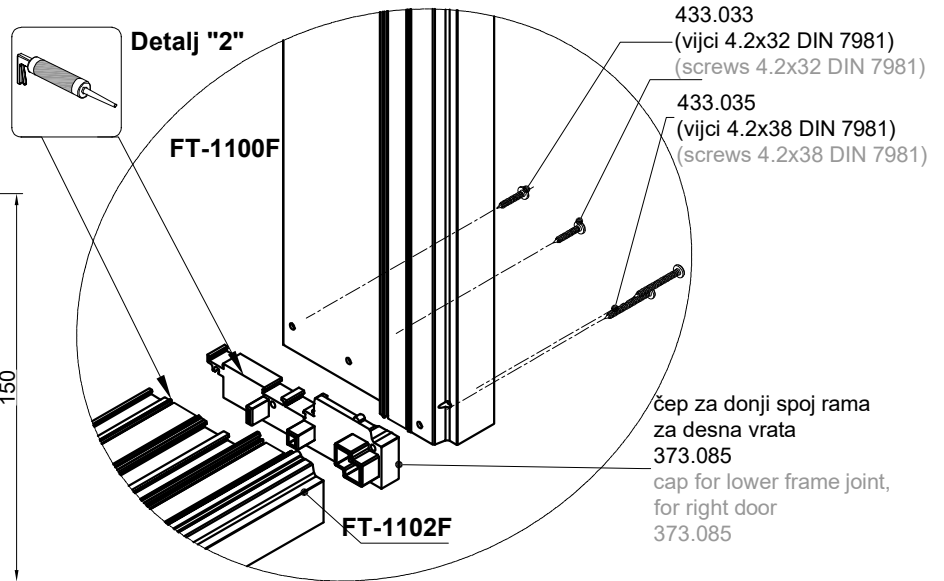

Detalj "2"

433.033  
(vijci 4.2x32 DIN 7981)  
(screws 4.2x32 DIN 7981)

433.035  
(vijci 4.2x38 DIN 7981)  
(screws 4.2x38 DIN 7981)

čep za donji spoj rama  
za desna vrata  
373.085  
cap for lower frame joint,  
for right door  
373.085

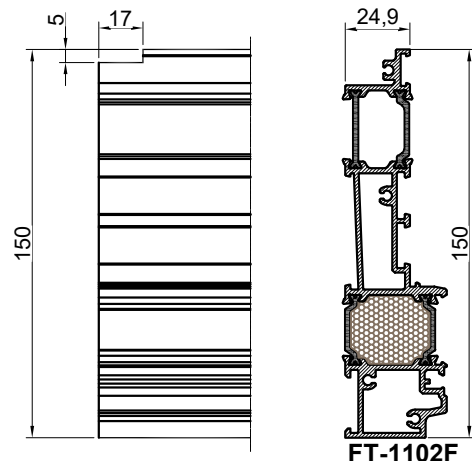

FT-1102F

Obrada profila FT-1102F  
prema vertikalnom profilu rama FT-1103F  
Processing profile FT-1102F  
towards vert. frame profile FT-1103F

Detalj "1"

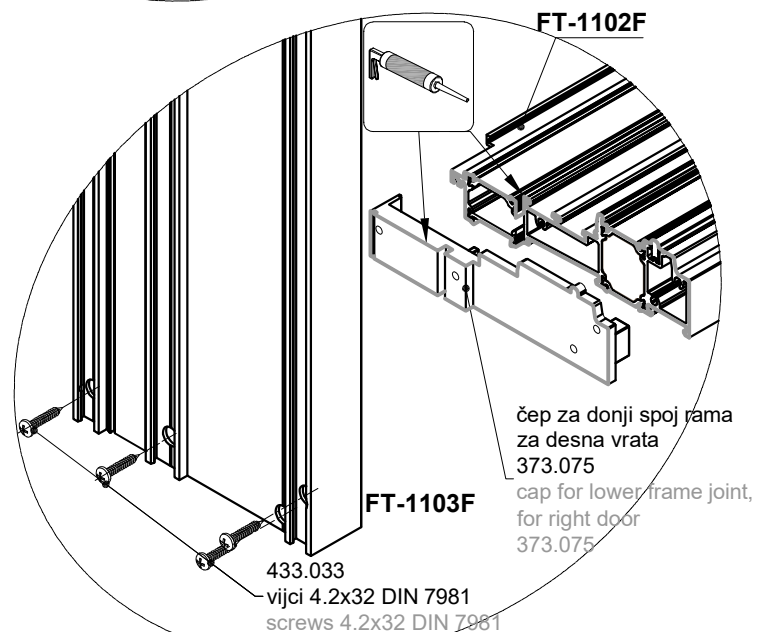

FT-1102F

čep za donji spoj rama  
za desna vrata  
373.075  
cap for lower frame joint,  
for right door  
373.075

433.033  
vijci 4.2x32 DIN 7981  
screws 4.2x32 DIN 7981

FT-1103F

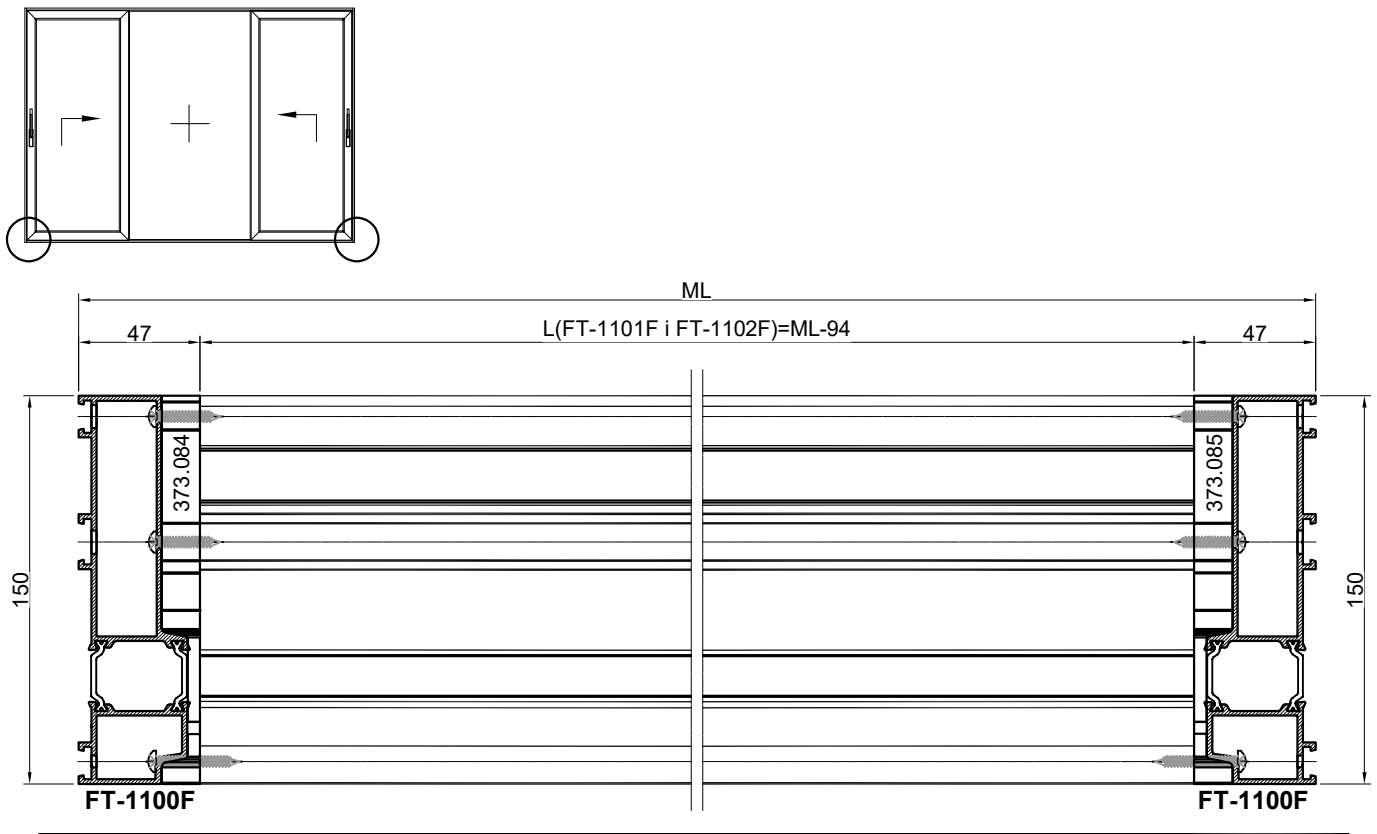
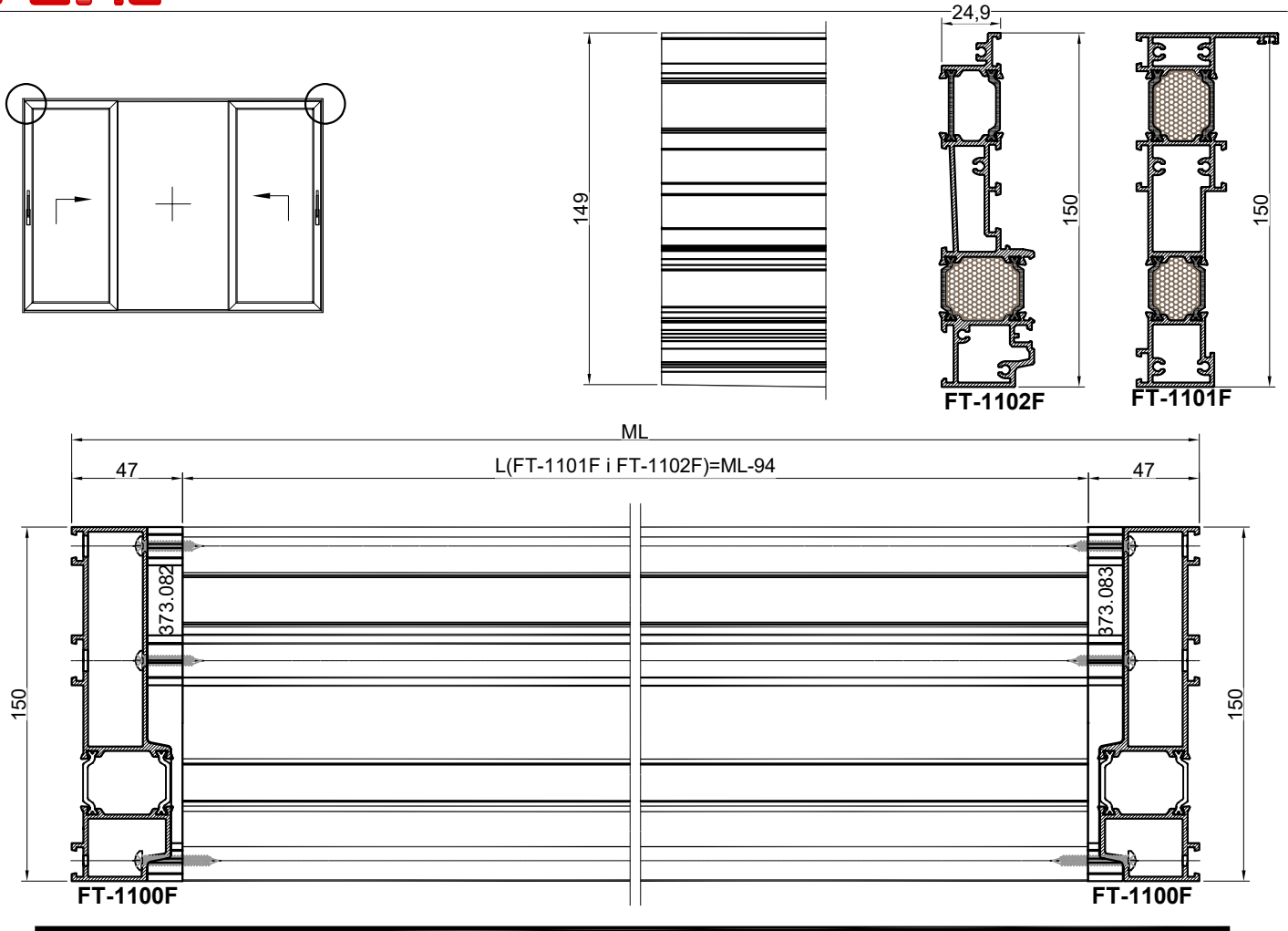

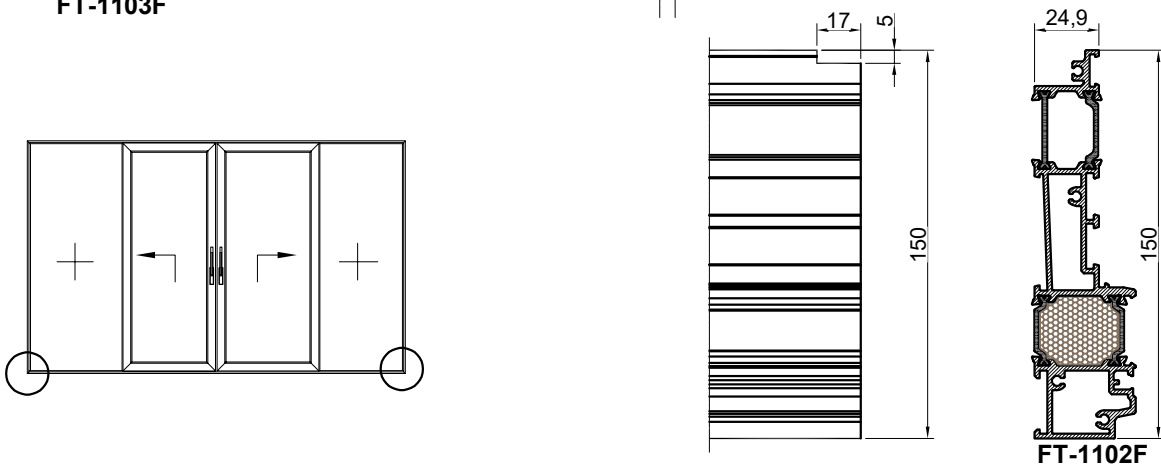
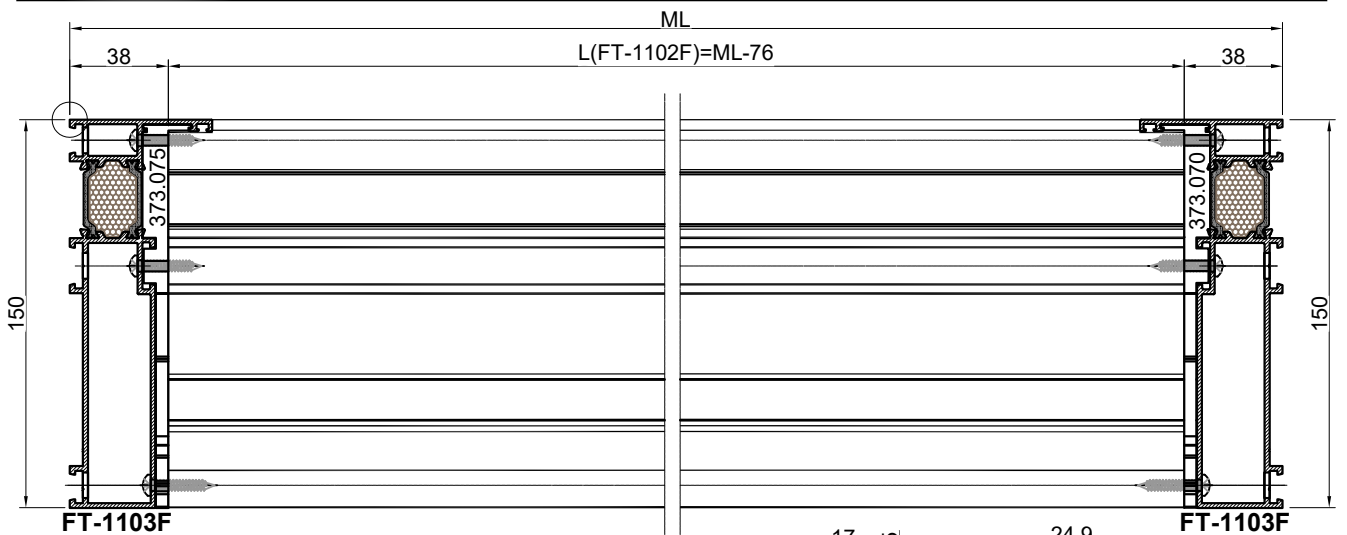
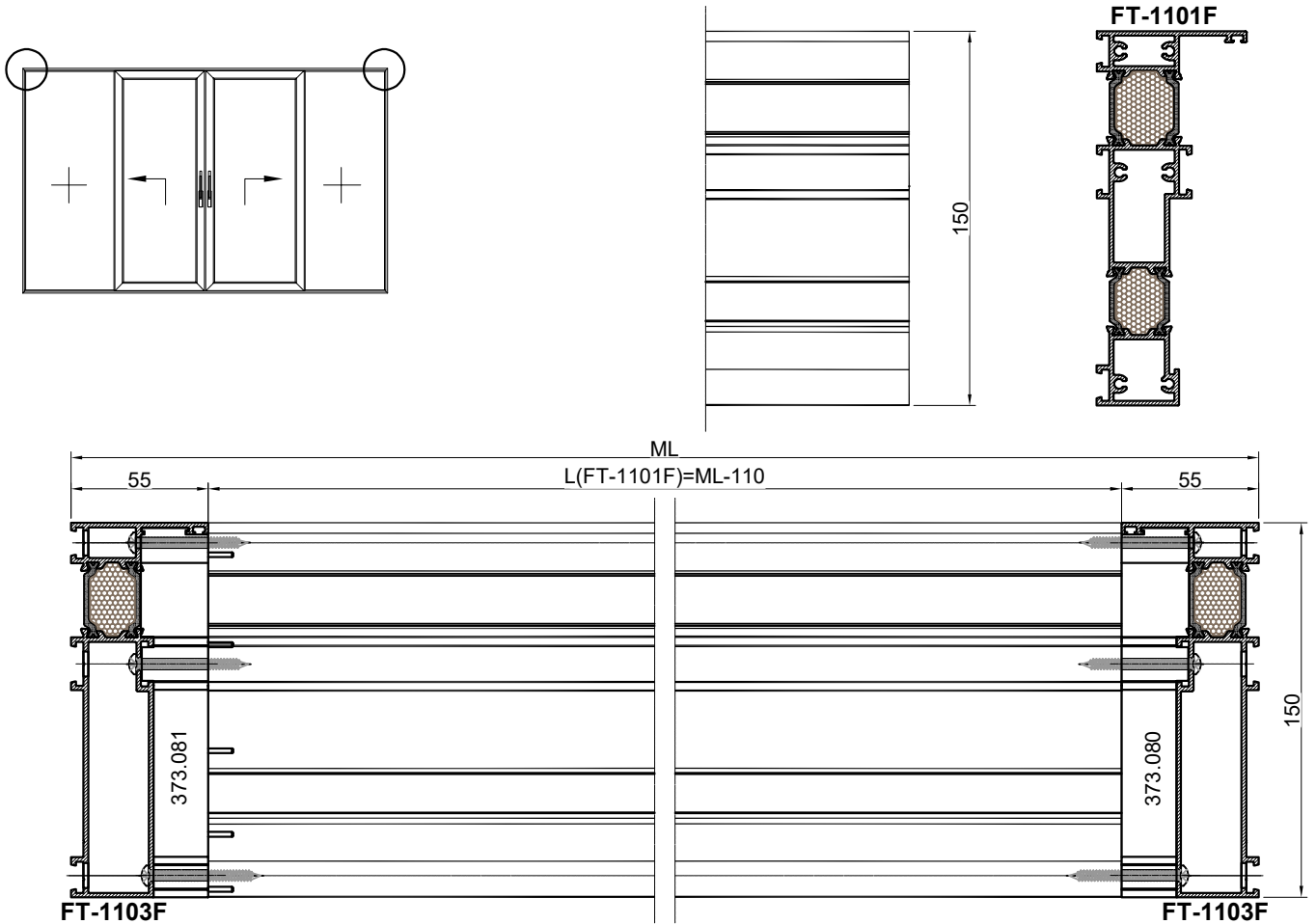



# Rezne liste

## Cutting lists



#### PODIZNO-KLIZNA DVOKRILNA VRATA SA KRILOM FT-1020 LIFT AND SLIDE DOUBLE DOOR WITH SASH FT-1020

PROFILI PROFILES			kom pcs	mjera measure	pilanje cutting
FT-1000F	gornja vodoravnica rama	upper horiz. frame profile	1	L-86	90-90
FT-1001F	donja vodoravnica rama	lower horiz. frame profile	1	L-86	90-90
FT-1002F	okomica rama	vertical frame profile	2	H	90-90
FT-1020F	okomica krila	vertical sash profile	4	Hkr=H-84	45-45
FT-1020F	vodoravnica krila	horizontal sash profile	4	Lkr=L/2+4	45-45
F-1300	okapnica	drip cap	1	L-60	90-90
F-1433	profil na spoju krila	sash joint profile	2	H-84	90-90
F-1112	vodilica	guide	1	L-68	90-90
Z40-664	lajsna okomita	vertical bead	4	Hkr-168	90-90
Z40-664	lajsna vodoravna	horizontal bead	4	Lkr-124	90-90
378.002	vodoravni profil donji	lower horizontal profile	1	L-86	90-90
378.003	vodoravni profil gornji	upper horizontal profile	1	L-86	90-90
378.004	okomiti profil	vertical profile	2	H	90-90
372.004	profil na spoju krila	sash joint profile	2	H-84	90-90
<b>OKOVI HARDWARE</b>					
363.043	set pvc za spoj rama (lij. vrata)	pvc set for frame joint (lft. door)	1		
710.490	centralni kutnik krila	central sash corner bracket	8		
710.188	pomoćni kutnik krila	support sash corner bracket	8		
731.010	pomoćni kutnik krila	support sash corner bracket	8		
730.017	pomoćni kutnik krila	supprt sash corner bracket	16		
374.122	pvc podmetač ispod kotačića	pvc insert under rollers	1		
149.046	kotačići (200 kg)	bogies(200 kg)	2		
149.012	spojnica kotačića*	connecting rod*	2		
149.008	brava za ključanje*	espag. locking cylinder*	2		
108.006	pogonska ručka	driving handle	2		
149.025	zapinjači na ramu	locking bolts	2		
373.078	usmjerivač krila	sash guide	8		
340.082	č.umetak na spoju krila,gore	s. insert on sash joint, up	1		
360.003	umetak na spoju krila - donji	insert on sash joint - lower	1		
360.005	umetak za F-1433-donji	insert for F-1433-lower	2		
360.007	umetak za F-1433-gornji	insert for F-1433-upper	2		
360.009	monodrain cjevčica	monodrain tubule	4		
375.020	ublaživač udara krila	sash hit bumper	2		
<b>BRTVE GASKETS</b>					
327.003	brtva krila prema ramu	sash gasket towards frame	2L+4H		
348.067	brtva u krilo-ram,gornji pojas	sash-frame gasket,upper zone	2L		
341.007	brtva na spoju krila	sash joint gasket	2H		
348.008	brtva kliznog krila prema ramu	sliding sash gask. towards frame	L+2H		
347.012	brtva	gasket	2H		
340.028	okrugla brtva Ø6	round gasket Ø6	2L		
340.029	okrugla brtva Ø4	round gasket Ø4	2L+4H		
328.002	brtva prema staklu vani	gasket to the glass-exterior	2L+4H		
311.004	brtva prema staklu unutra	gasket to the glass-interior	2L+4H		
340.013	izoterm plamaframe	isotherm plamaframe	2L+4H		
340.027	termoblok za FT-1020	thermoblock for FT-1020	L		
340.024	tb na spoju krila FT-1020	tb on joint sash FT-1020	H		
340.025	tb na spoju krila FT-1020	tb on joint sash FT-1020	H		

#### STAKLO GLASS

44 mm

- Okov za podizno klizne sisteme

izabrati iz kataloga poglavlje mehanizmi

406.08.002... (\*-ovisno o dimenziji)

- Hardware for slide and lift-slide systems to choose

from catalog from mechanisms chapter

page 406.08.02... (\*-depending on the dimension)

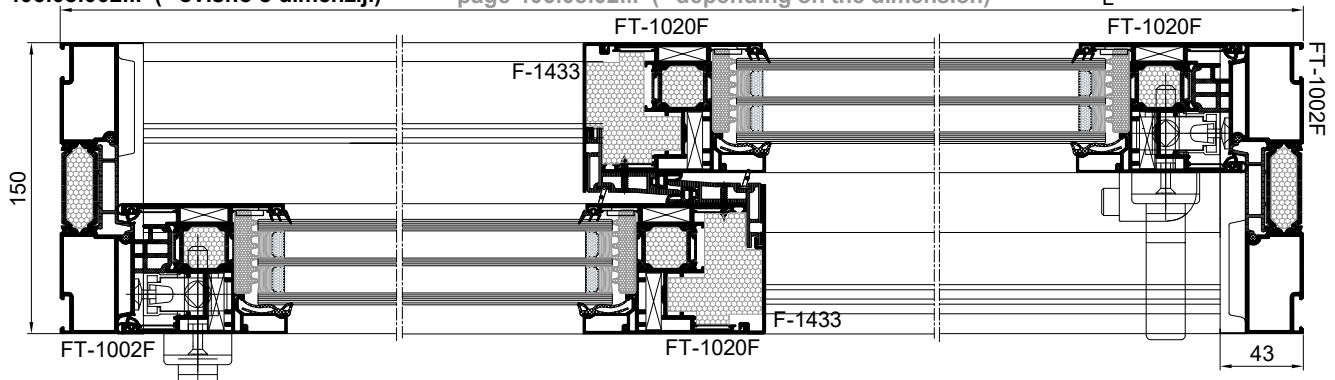
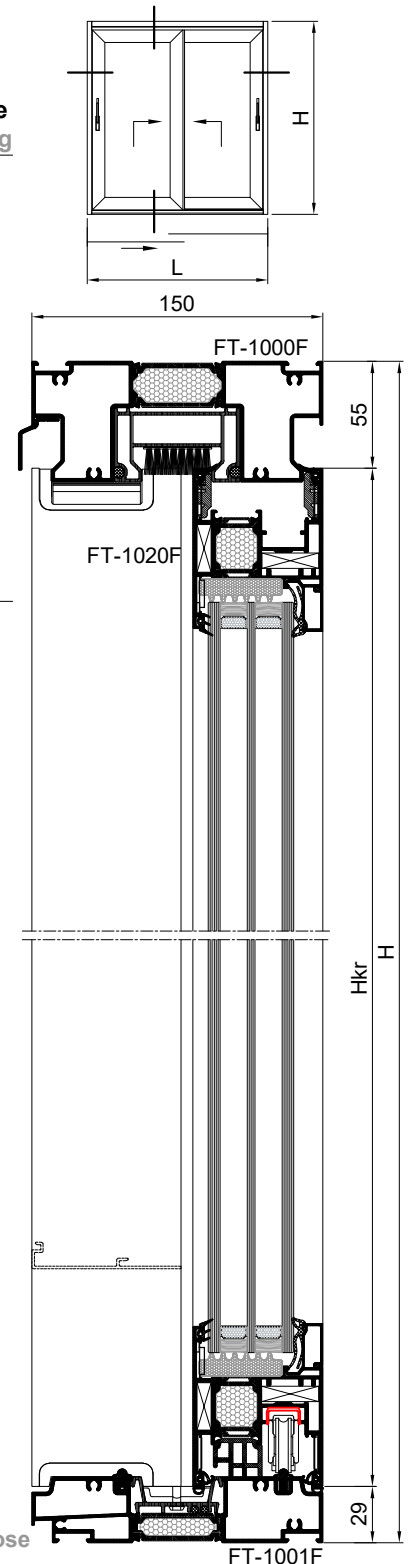

#### PODIZNO-KLIZNA DVOKRILNA VRATA SA KRILOM FT-1022 LIFT AND SLIDE DOUBLE DOOR WITH SASH FT-1022

PROFIL PROFILES		kom pcs	mjera measure	pilanje cutting
FT-1000F gornja vodoravnica rama	upper horiz. frame profile	1	L-86	90-90
FT-1001F donja vodoravnica rama	lower horiz. frame profile	1	L-86	90-90
FT-1002F okomica rama	vert. frame profile	2	H	90-90
FT-1022F okomica krila	vert. sash profile	4	Hkr=H-84	45-45
FT-1022F vodoravnica krila	horiz. sash profile	4	Lkr=L/2+9	45-45
F-1300 okapnica	drip cap	1	L-60	90-90
F-1433 profil na spoju krila	sash joint profile	2	H-84	90-90
F-1112 vodilica	guide	1	L-68	90-90
Z40-664 lajsna okomita	vertical bead	4	Hkr-188	90-90
Z40-664 lajsna vodoravna	horizontal bead	4	Lkr-144	90-90
378.002 vodoravni profil donji	lower horizontal profile	1	L-86	90-90
378.003 vodoravni profil gornji	upper horizontal profile	1	L-86	90-90
378.004 okomiti profil	vertical profile	2	H	90-90
374.078 profil na spoju krila	sash joint profile	2	H-84	90-90
<b>OKOVI HARDWARE</b>				
363.043 set pvc za spoj rama (l.vrata)	pvc set for frame joint (lft. door)	1		
710.490 centralni kutnik krila	central sash corner bracket	8		
710.189 pomoćni kutnik krila	support sash corner bracket	8		
731.010 pomoćni kutnik krila	support sash corner bracket	8		
730.017 pomoćni kutnik krila	supprt sash corner bracket	16		
149.035 kotačići (330 kg)	bogies (330 kg)	2		
149.012 spojnica kotačića*	connecting rod*	2		
149.020 brava za ključanje*	espag. locking cylinder*	2		
108.006 pogonska ručka	driving handle	2		
149.025 zapinjači na ramu	locking bolts	2		
373.078 usmjerivač krila	sash guide	8		
340.082 č. umetak na spoju krila,gore	s. insert on sash joint, up	1		
360.003 umetak na spoju krila-donji	insert on sash joint - lower	1		
360.005 umetak za F-1433-donji	insert for F-1433-lower	2		
360.007 umetak za F-1433-gornji	insert for F-1433-upper	2		
360.009 monodrain cjevčica	monodrain tubule	4		
375.020 ublaživač udara krila	sash hit bumper	2		
<b>BRTVE GASKETS</b>				
327.003 brtva krila prema ramu	sash gasket towards frame	2L+4H		
348.067 brtva u krilo-ram,gornji pojas	sash-frame gasket,upper zone	2L		
344.113 brtva na spoju krila	sash joint gasket	2H		
348.008 brtva kliznog krilo -ram	sliding sash gask. towards frame	L+2H		
347.012 brtva	gasket	4H		
340.028 okrugla brtva Ø6	round gasket Ø6	2L		
340.029 okrugla brtva Ø4	round gasket Ø4	2L+4H		
328.002 brtva prema staklu vani	gasket to the glass-exterior	2L+4H		
311.004 brtva prema staklu unutra	gasket to the glass-interior	2L+4H		
340.013 izoterm plamaframe	isotherm plamaframe	2L+4H		
340.050 termoblok za FT-1022	thermoblock for FT-1022	L		
340.051 tb na spoju krila FT-1022	tb on joint sash FT-1022	H		
340.052 tb na spoju krila FT-1022	tb on joint sash FT-1022	H		

#### STAKLO GLASS

44 mm

- Okov za podizno klizne sisteme

izabrati iz kataloga poglavlje mehanizmi

406.08.006... (\*-ovisno o dimenziji)

2

Lkr-158 x Hkr-158

- Hardware for slide and lift-slide systems to choose

from catalog from mechanisms chapter

page 406.08.06... (\*-depending on the dimension)

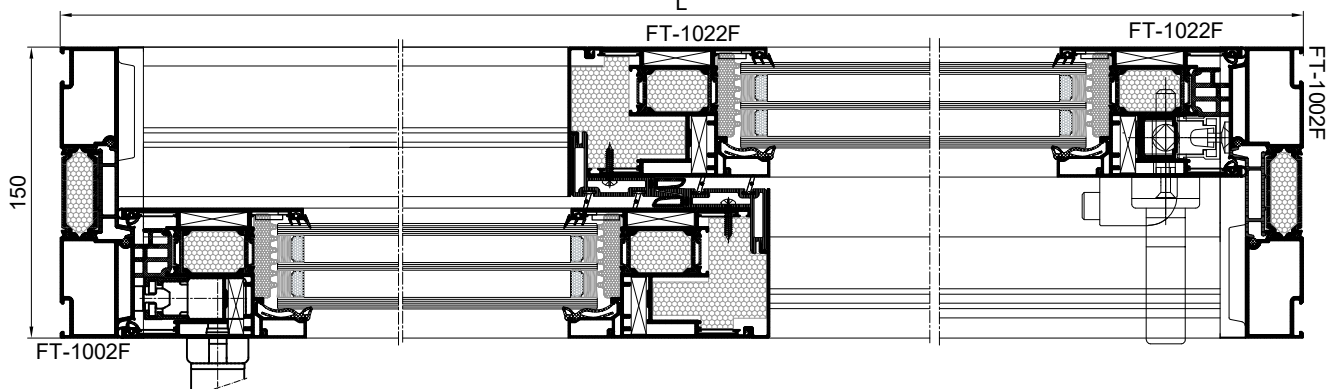
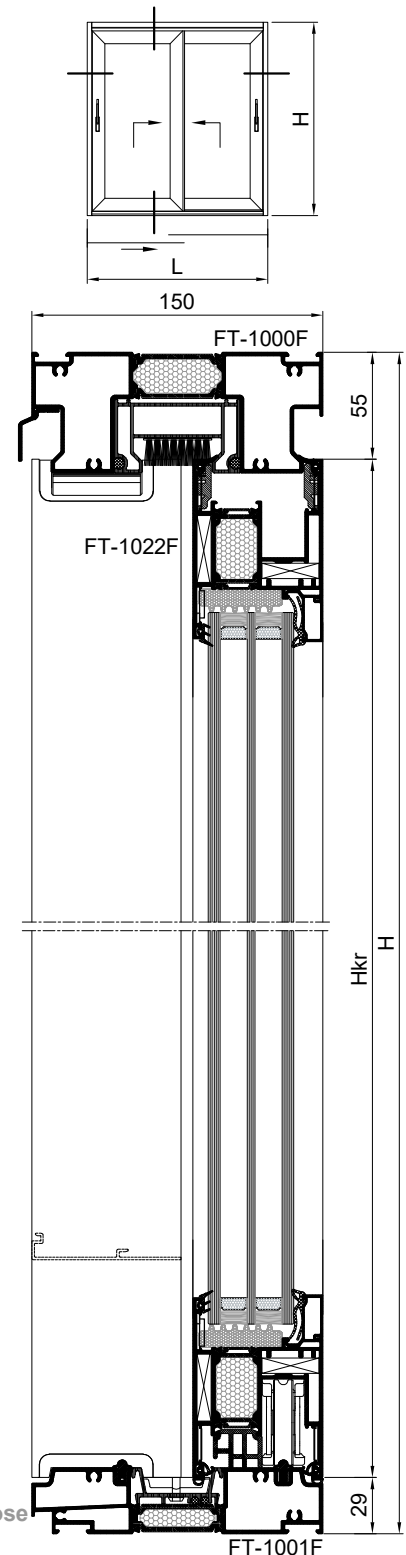

### PODIZNO-KLIZNA ČETVEROKRILNA VRATA SA KRILOM FT-1020 LIFT AND SLIDE FOUR SASH DOOR WITH SASH FT-1020

PROFILI PROFILES			kom pcs	mjera measure	pilanje cutting
FT-1000F	gornja vodoravnica rama	upper horiz. frame profile	1	L-86	90-90
FT-1001F	donja vodoravnica rama	lower horiz. frame profile	1	L-86	90-90
FT-1002F	okomica rama	vert. frame profile	2	H	90-90
FT-1020F	okomica krila	vert. sash profile	8	Hkr=H-84	45-45
FT-1020F	vodoravnica krila	horiz sash profile	8	Lkr=L/4+19	45-45
F-1300	okapnica	drip cap	1	L-60	90-90
F-1433	profil na spoju krila	sash joint profile	4	H-84	90-90
F-1112	vodilica	guide	1	L-60	90-90
Z40-664	lajsna okomita	vertical bead	8	Hkr-168	90-90
Z40-664	lajsna vodoravna	horizontal bead	8	Lkr-124	90-90
378.002	vodoravni profil donji	lower horizontal profile	1	L-86	90-90
378.003	vodoravni profil gornji	upper horizontal profile	1	L-86	90-90
378.004	okomiti profil	vertical profile	2	H	90-90
372.004	profil na spoju krila	sash joint profile	4	H-84	90-90
FT-1030	profil na sudaru krila	sash hit profile	1	H-84	90-90

#### OKOVI HARDWARE

363.047	set pvc umetaka za spoj rama	pvc set for frame joint (lift. door)	1		
710.490	centralni kutnik krila	central sash corner bracket	16		
710.188	pomoćni kutnik krila	support sash corner bracket	16		
731.010	pomoćni kutnik krila	support sash corner bracket	16		
730.017	pomoćni kutnik krila	supprt sash corner bracket	32		
374.122	pvc podmetač ispod kotačića	pvc insert under rollers	1		
149.046	kotačići (200 kg)	bogies (200 kg)	4		
149.012	spojnica kotačića	connecting rod	4		
149.008	brava za ključanje	espag. locking cylinder	4		
108.006	pogonska ručka	driving handle	4		
149.025	zapinjači na ramu	locking bolts	3		
373.078	usmjerivač krila	sash guide	16		
340.082	č. umetak na spoju krila-gornji	s. insert on sash joint, up	2		
360.003	umetak na spoju krila-donji	insert on sash joint - lower	2		
363.030	umetak profila FT-1030	insert for F-1030	par		
360.004	umetak profila F-1433-donji	insert for F-1433-lower	2		
360.005	umetak profila F-1433-donji	insert for F-1433-lower	2		
360.007	umetak profila F-1433-gornji	insert for F-1433-upper	4		
360.009	monodrain cjevčica	monodrain tubule	8		
375.020	ublaživač udara krila	sash hit bumper	4		

#### BRTVE GASKETS

327.003	brtva krila prema ramu	sash gasket towards frame	2L+6H		
348.067	brtva u krilo-ram, gore	sash-frame gasket, upper zone	2L		
341.007	brtva na spoju krila	sash joint gasket	4H		
341.008	brtva kliznog krilo-ram	sliding sash gask. towards frame	3/4L+3H		
347.012	brtva	gasket	4H		
340.028	okrugla brtva Ø6	round gasket Ø6	2L		
340.029	okrugla brtva Ø4	round gasket Ø4	2L+4H		
328.002	brtva prema staklu vani	gasket to the glass-exterior	2L+8H		
311.004	brtva prema staklu unutra	gasket to the glass-interior	2L+8H		
340.013	izoterm plamaframe	isotherm plamaframe	2L+8H		
340.027	termoblok za FT-1020	thermoblock for FT-1020	L		
340.024	tb na spoju krila FT-1020	tb on joint sash FT-1020	2H		
340.025	tb na spoju krila FT-1020	tb on joint sash FT-1020	2H		
340.075	tb na sudaru krila FT-1020	tb on joint sash FT-1020	H		

#### STAKLO GLASS

44 mm

- Okov za podizno klizne sisteme

izabrati iz kataloga poglavlje mehanizmi  
406.08.002... (\*-ovisno o dimenziji)

- Hardware for slide and lift-slide systems to choose

from catalog from mechanisms chapter  
page 406.08.02... (L depending on the dimension)

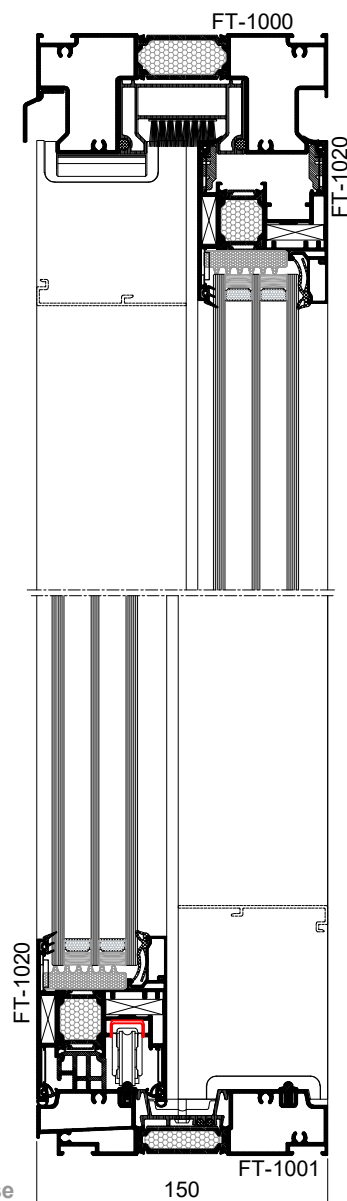
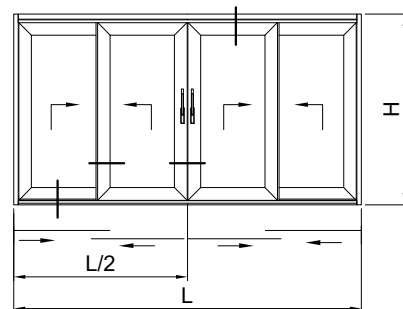
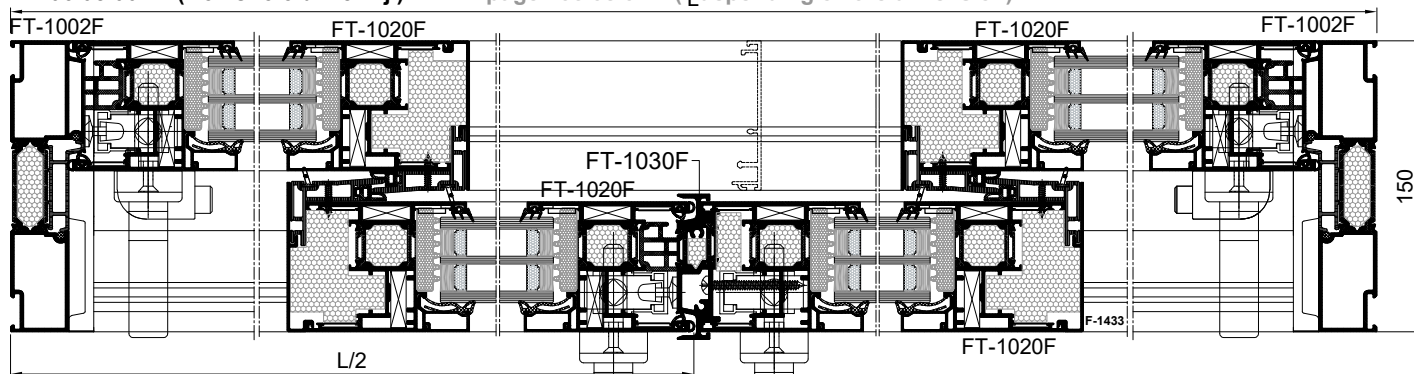

#### PODIZNO-KLIZNA ČETVEROKRILNA VRATA SA KRILOM FT-1022 LIFT AND SLIDE FOUR SASH DOOR WITH SASH FT-1022

PROFILI PROFILES			kom pcs	mjera measure	pilanje cutting
FT-1000F	gornja vodoravnica rama	upper horiz. frame profile	1	L-86	90-90
FT-1001F	donja vodoravnica rama	lower horiz. frame profile	1	L-86	90-90
FT-1002F	okomica rama	vert. frame profile	2	H	90-90
FT-1022F	okomica krila	vert. sash profile	8	Hkr=H-84	45-45
FT-1022F	vodoravnica krila	horiz. sash profile	8	Lkr=L/4+24	45-45
F-1300	okapnica	drip cap	1	L-60	90-90
F-1433	profil na spoju krila	joint sash profile	4	H-84	90-90
F-1112	vodilica	guide	1	L-60	90-90
Z40-664	lajsna okomita	vertical bead	8	Hkr-188	90-90
Z40-664	lajsna vodoravna	horizontal bead	8	Lkr-144	90-90
378.002	vodoravni profil donji	lower horizontal profile	1	L-86	90-90
378.003	vodoravni profil gornji	upper horizontal profile	1	L-86	90-90
378.004	okomiti profil	vertical profile	2	H	90-90
374.078	profil na spoju krila	sash joint profile	4	H-84	90-90
FT-1030	profil na sudaru krila	sash hit profile	1	H-84	90-90

#### OKOVI HARDWARE

363.047	set pvc umetaka za spoj rama	pvc set for frame joint (lift. door)	1		
710.490	centralni kutnik krila	central sash corner bracket	16		
710.189	pomoćni kutnik krila	support sash corner bracket	16		
731.010	pomoćni kutnik krila	support sash corner bracket	16		
730.017	pomoćni kutnik krila	supprt sash corner bracket	32		
149.035	kotačići (300 kg)	bogies (300g)	4		
149.012	spojnica kogačića	connecting rod	4		
149.020	brava za ključanje	espag. locking cylinder	4		
108.006	pogonska ručka	driving handle	4		
149.025	zapinjači na ramu	locking bolts	3		
373.078	usmjerivač krila	sash guide	16		
340.082	č. umetak na spoju krila-gornji	s. insert on sash joint, up	2		
360.003	umetak na spoju krila-donji	insert on sash joint - lower	2		
363.030	umetak profila FT-1030	insert for F-1030	par		
360.004	umetak profila F-1433-donji	insert for F-1433-lower	2		
360.005	umetak profila F-1433-donji	insert for F-1433-lower	2		
360.007	umetak profila F-1433-gornji	insert for F-1433-upper	4		
360.009	monodrain cjevčica	monodrain tubule	8		
375.020	ublaživač udara krila	sash hit bumper	4		

#### BRTVE GASKETS

327.003	brtva krila prema ramu	sash gasket towards frame	2L+6H
348.067	brtva u krilo-ram, gornji pojas	sash-frame gasket, upper zone	2L
344.113	brtva na spoju krila	sash joint gasket	4H
348.008	brtva kliznog krila prema ramu	sliding sash gask. towards frame	3/4L+3H
347.003	brtva	gasket	4H
340.028	okrugla brtva Ø6	round gasket Ø6	2L
340.029	okrugla brtva Ø4	round gasket Ø4	2L+4H
328.002	brtva prema staklu vani	gasket to the glass-exterior	2L+8H
311.004	brtva prema staklu unutra	gasket to the glass-interior	2L+8H
340.013	izoterm plamaframe	isotherm plamaframe	2L+8H
340.050	termoblok za FT-1022	thermoblock for FT-1022	L
340.051	tb na spoju krila FT-1022	tb on joint sash FT-1022	2H
340.052	tb na spoju krila FT-1022	tb on joint sash FT-1022	2H
340.075	tb na sudaru krila FT-1022	tb on joint sash FT-1022	H

#### STAKLO GLASS

44 mm  
- Okov za podizno klizne sisteme - Hardware for slide and lift-slide systems to choose  
izabrati iz kataloga poglavlje mehanizmi from catalog from mechanisms chapter  
406.08.006... (\*-ovisno o dimenziji) page 406.08.06... (\*-depending on the dimension)

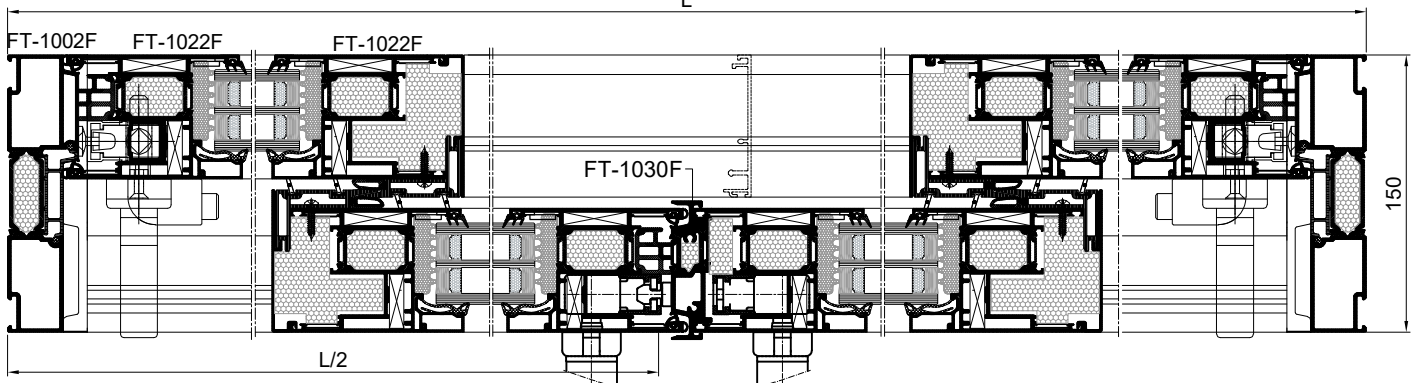
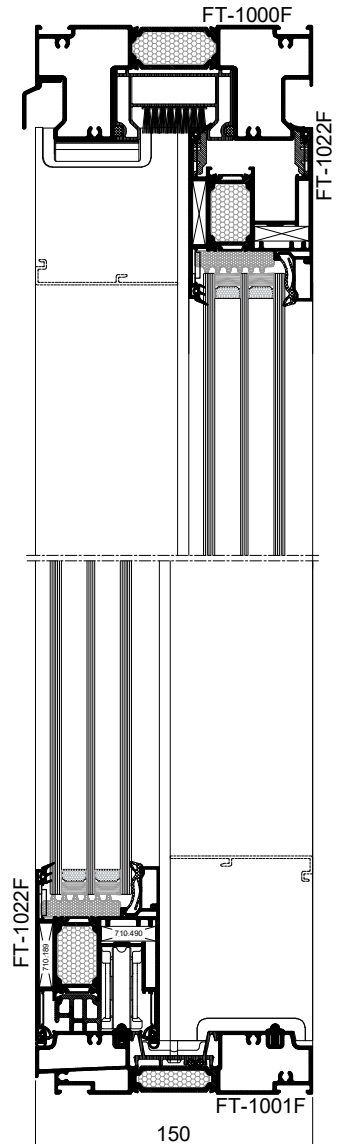
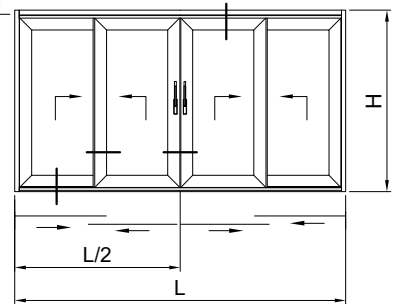

PODIZNO-KLIZNA TROKRILNA LIJEVA VRATA SA KRILOM FT-1020  
LIFT AND SLIDE THREE SASH LEFT DOOR WITH SASH FT-1020

PROFIL PROFILES			kom pcs	mjera measure	pilanje cutting
FT-1003F	gornja vodoravnica rama	upper horiz.frame profile	1	L-60	90-90
FT-1004F	donja vodoravnica rama	lower horiz.frame profile	1	L-60	90-90
FT-1005F	okomica rama	vert. frame profile	2	H	90-90
FT-1020F	okomica krila	vert.sash profile	6	Hkr=H-84	45-45
FT-1020F	vodoravnica krila	horiz.sash profile	6	Lkr=L/3+27	45-45
F-1300	okapnica	drip cap	1	L-60	90-90
F-1433	profil na spoju krila	sash joint profile	4	H-84	90-90
F-1112	vodilica	guide	2	L-60	90-90
Z40-664	lajsna okomita	vertical bead	6	Hkr-168	90-90
Z40-664	lajsna vodoravna	horizontal bead	6	Lkr-124	90-90
378.002	vodoravni profil donji	lower horizontal profile	2	L-73	90-90
378.003	vodoravni profil gornji	upper horizontal profile	2	L-73	90-90
378.004	okomiti profil	vertical profile	2	H	90-90
372.004	profil na spoju krila	sash joint profile	4	H-84	90-90
<b>OKOVI HARDWARE</b>					
363.045	set pvc za spoj rama (l.vrata)	pvc set for frame joint (lft. door)	1		
710.490	centralni kutnik krila	central sash corner bracket	12		
710.188	pomoćni kutnik krila	support sash corner bracket	12		
731.010	pomoćni kutnik krila	support sash corner bracket	12		
730.017	pomoćni kutnik krila	supprt sash corner bracket	24		
374.122	pvc podmetač ispod kotačića	pvc insert under rollers	1		
149.046	kotačići (200 kg)	bogies (200g)	3		
149.012	spojnica kotačića	connecting rod	3		
149.008	brava za ključanje	espag. locking cylinder	3		
108.006	pogonska ručka	driving handle	3		
149.025	zapinjači na ramu	locking bolts	2		
373.078	usmjerivač krila	sash guide	12		
340.082	č.umetak na spoju krila-gornji	s. insert on sash joint, up	2		
360.003	umetak na spoju krila-donji	insert on sash joint - lower	2		
360.004	umetak profila F-1433-donji	insert for F-1433-lower	2		
360.005	umetak profila F-1433-donji	insert for F-1433-lower	2		
360.007	umetak profila F-1433-gornji	insert for F-1433-upper	4		
360.009	monodrain cjevčica	monodrain tubule	6		
375.020	ublaživač udara krila	sash hit bumper	2		
<b>BRTVE GASKETS</b>					
327.003	brtva krila prema ramu	sash gasket towards frame	2L+4H		
348.067	brtva u krilo-ram, gore	sash-frame gasket,upper zone	2L		
348.007	brtva na spoju krila	sash joint gasket	4H		
341.008	brtva kliznog krila prema ramu	sliding sash gask. towards frame	L+2H		
347.012	brtva	gasket	4H		
340.028	okrugla brtva Ø6	round gasket Ø6	4L		
340.029	okrugla brtva Ø4	round gasket Ø4	4L+4H		
328.002	brtva prema staklu vani	gasket to the glass-exterior	2L+6H		
311.004	brtva prema staklu unutra	gasket to the glass-interior	2L+6H		
340.013	izoterm plamaframe	isotherm plamaframe	2L+6H		
340.027	termoblok za FT-1020	thermoblock for FT-1020	L		
340.024	tb na spoju krila FT-1020	tb on joint sash FT-1020	2H		
340.025	tb na spoju krila FT-1020	tb on joint sash FT-1020	2H		

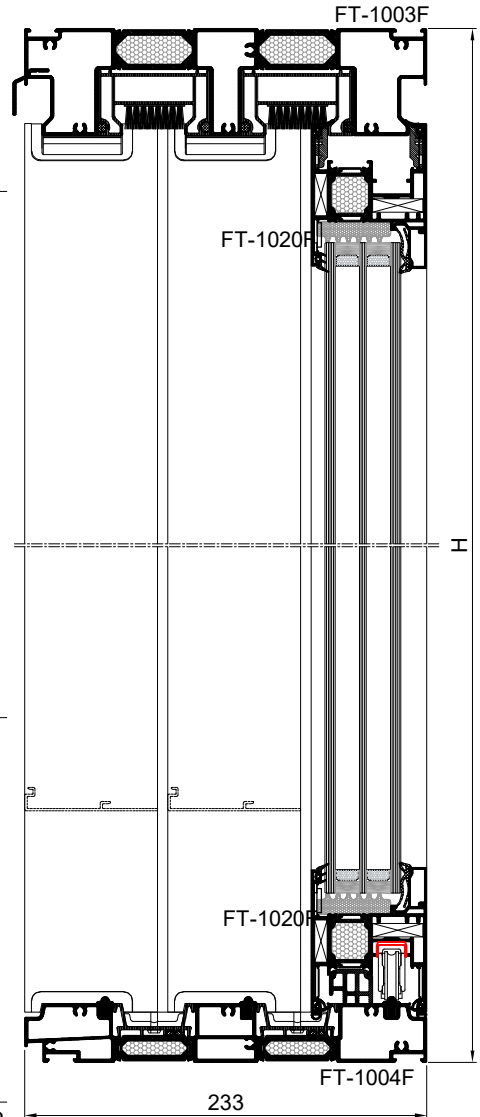
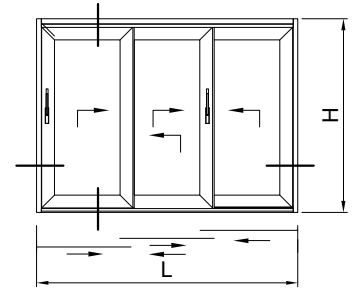

**STAKLO GLASS**

44 mm 3 Lkr-138 x Hkr-138

- Okov za podizno klizne sisteme - Hardware for slide and lift-slide systems to choose  
izabрати из каталога поглавље механизми from catalog from mechanisms chapter

406.08.002... (\*-ovisno o dimenziji) page 406.08.02... (\*-depending on the dimension)

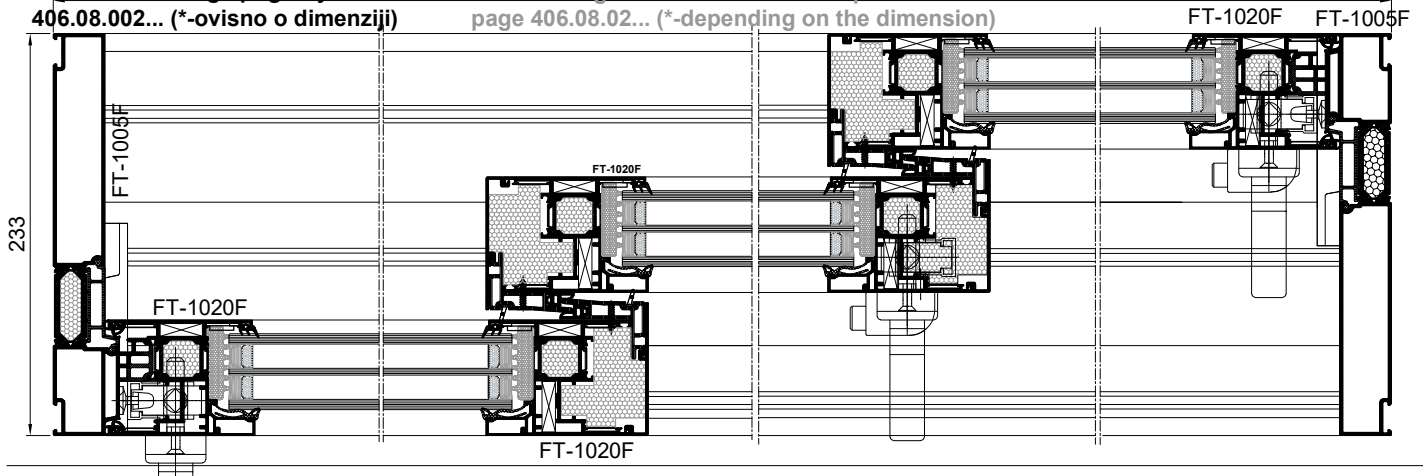

PODIZNO-KLIZNA TROKRILNA LIJEVA VRATA SA KRILOM FT-1022  
LIFT AND SLIDE THREE SASH LEFT DOOR WITH SASH FT-1022

PROFIL PROFILES			kom mjera		pilanje
			pcs	measure	
FT-1003F	gornja vodoravnica rama	upper horiz.frame profile	1	L-60	90-90
FT-1004F	donja vodoravnica rama	lower horiz. frame profile	1	L-60	90-90
FT-1005F	okomica rama	vert. frame profile	2	H	90-90
FT-1022F	okomica krila	vert. sash profile	6	Hkr=H-84	45-45
FT-1022F	vodoravnica krila	horiz sash profile	6	Lkr=L/3+34	45-45
F-1300	okapnica	drip cap	1	L-60	90-90
F-1433	profil na spoju krila	sash joint profile	4	H-84	90-90
F-1112	vodilica	guide	2	L-60	90-90
Z40-664	lajsna okomita	vertical bead	6	Hkr-188	90-90
Z40-664	lajsna vodoravna	horizontal bead	6	Lkr-144	90-90
378.002	vodoravni profil donji	lower horizontal profile	2	L-73	90-90
378.003	vodoravni profil gornji	upper horizontal profile	2	L-73	90-90
378.004	okomiti profil	vertical profile	2	H	90-90
374.078	profil na spoju krila	sash joint profile	4	H-84	90-90
<b>OKOVI HARDWARE</b>					
363.045	set pvc za spoj rama (l. vrata)	pvc set for frame joint (lft. door)	1		
710.490	centralni kutnik krila	central sash corner bracket	12		
710.189	pomoćni kutnik krila	support sash corner bracket	12		
731.010	pomoćni kutnik krila	support sash corner bracket	12		
730.017	pomoćni kutnik krila	supprt sash corner bracket	24		
149.035	kotačići (300 kg)	bogies (300g)	3		
149.012	spojnica kotačića	connecting rod	3		
149.020	brava za ključanje	espag. locking cylinder	3		
108.006	pogonska ručka	driving handle	3		
149.025	zapinjači na ramu	locking bolts	2		
373.078	usmjerivač krila	sash guide	12		
340.082	č.umetak na spoju krila, gore	s. insert on sash joint, up	2		
360.003	umetak na spoju krila-donji	insert on sash joint - lower	2		
360.004	umetak profila F-1433-donji	insert for F-1433-lower	2		
360.005	umetak profila F-1433-donji	insert for F-1433-lower	2		
360.007	umetak profila F-1433-gornji	insert for F-1433-upper	4		
360.009	monodrain cjevčica	monodrain tubule	6		
375.020	ublaživač udara krila	sash hit bumper	2		
<b>BRTVE GASKETS</b>					
327.003	brtva krila prema ramu	sash gasket towards frame	2L+4H		
348.067	brtva u krilo-ram-gore	sash-frame gasket,upper zone	2L		
344.113	brtva na spoju krila	sash joint gasket	4H		
348.008	brtva kliznog krila prema ramu	sliding sash gask. towards frame	L+2H		
347.012	brtva	gasket	8H		
340.028	okrugla brtva Ø6	round gasket Ø6	4L		
340.029	okrugla brtva Ø4	round gasket Ø4	4L+4H		
328.002	brtva prema staklu vani	gasket to the glass-exterior	2L+6H		
311.004	brtva prema staklu unutra	gasket to the glass-interior	2L+6H		
340.013	izoterm plamaframe	isotherm plamaframe	2L+6H		
340.050	termoblok za FT-1022	thermoblock for FT-1022	L		
340.051	tb na spoju krila FT-1022	tb on joint sash FT-1022	2H		
340.052	tb na spoju krila FT-1022	tb on joint sash FT-1022	2H		
<b>STAKLO GLASS</b>					
44 mm			3	Lkr-158 x Hkr-158	

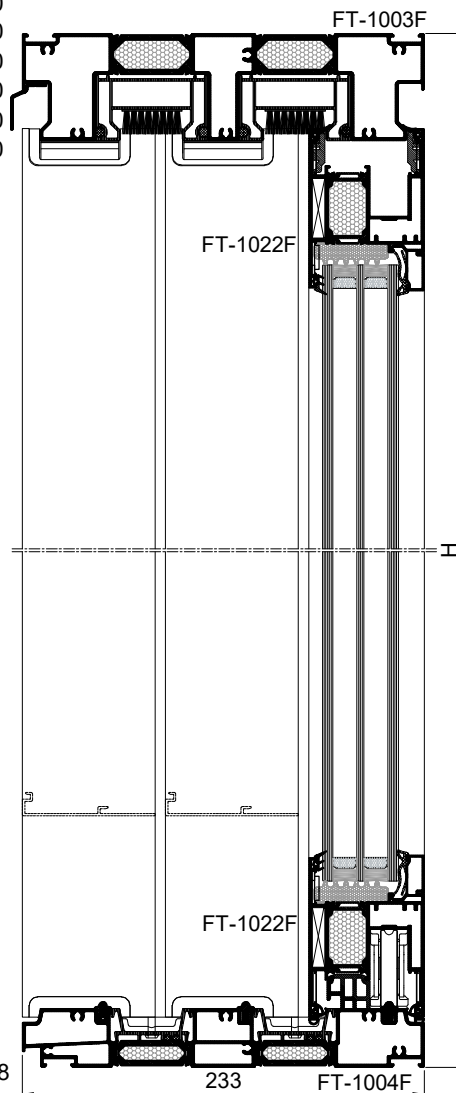
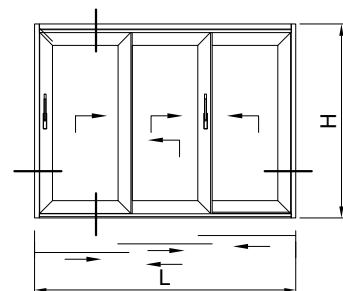

- Okov za podizno klizne sisteme  
izabrati iz kataloga poglavlje mehanizmi  
406.08.06...

- Hardware for slide and lift-slide systems to choose  
from catalog from mechanisms chapter  
page 406.08.06... L

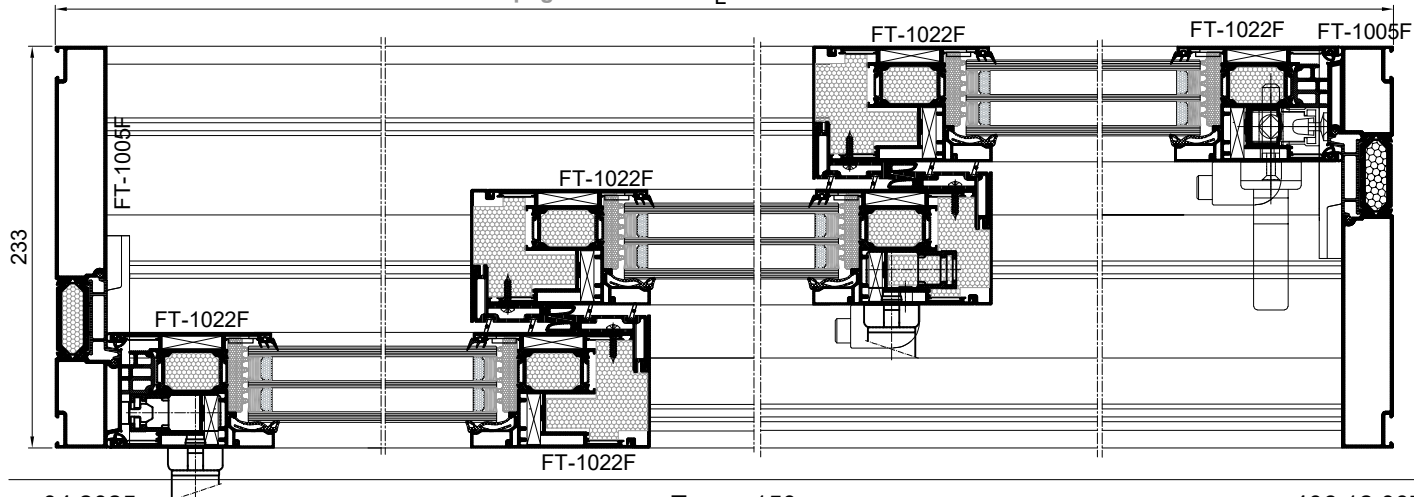

naziv name	mjera measure	kom. pcs.	pilanje cutting	
Okomica rama FT-1100F	Frame vertical FT-1100F	MH	1	90-90
Okomica rama FT-1103F	Frame vertical FT-1103F	MH	1	90-90
Vodoravnica rama-donja FT-1102F	Frame horizontal-lower FT-1102F	ML-70	1	90-90
Vodoravnica rama-gornja FT-1101F	Frame horizontal-upper FT-1101F	ML-65	1	90-90
Krilo FT-1120F	Sash FT-1120F	ML/2+6	2	45-45
Krilo FT-1120F	Sash FT-1120F	MH-87	2	45-45
Prečka FT-1131F	Mullion FT-1131F	MH-85	1	90-90
Umetak rama FT-1132F	Frame insert FT-1132F	ML-79	1	90-90
Maska F-1538	Mask F-1538	MH-63.5	1	90-90
Maska F-1538	Mask F-1538	MH-87	1	90-90
Maska praga F-1536	Threshold mask F-1536	ML-Lpreč.-37.5	1	90-90
Maska praga F-1418	Threshold mask F-1418	ML-59	1	90-90
Vanjska st lajsna F-1419	Exterior glazing bead F-1419	Lpreč.-147.5	1	90-90
Al vodilica F-1112 (elox)	Al guide F-1112 (elox)	ML-85	1	90-90
Maska F-1537	Mask F-1537	ML-Lpreč.-37	1	90-90
Maska F-1434	Mask F-1434	MH-85	1	90-90
Staklo lajsna Z40-664	Glazing bead Z40-664	Lkr-142	2	90-90
Staklo lajsna Z40-664	Glazing bead Z40-664	Hkr-186	2	90-90
Staklo lajsna Z40-664	Glazing bead Z40-664	Lpreč-104	2	90-90
Staklo lajsna Z40-664	Glazing bead Z40-664	MH-107	2	90-90
Kutna spojnica 710.401	Corner bracket 710.401		4	
Kutna spojnica 710.403	Corner bracket 710.403		4	
Kutna spojnica 731.010	Corner bracket 731.010		4	
Kutna spojnica 730.017	Corner bracket 730.017		8	
Čep prečke donji 373.067	Mullion cap-lower 373.067		1	
Čep prečke gornji 373.068	Mullion cap-upper 373.068		1	
Čep za donji spoj rama 373.070	Cap for lower frame joint 373.070		1	
Čep za gornji spoj rama 373.071	Cap for upper frame joint 373.071		1	
Čep maske krila donji 373.051 (lij.)	Cap mask on sash-lower 373.051 (lft.)		1	
Čep maske krila gornji 373.053	Cap mask on sash-upper 373.053		1	
Usmjerivač krila 373.078	Sash guide 373.078		4	
Čep za gornji spoj rama 363.056 (lij.)	Cap for upper frame joint 363.056 (lft.)		1	
Čep za donji spoj rama 363.058 (lij.)	Cap for lower frame joint 363.058 (lft.)		1	
Umetak za odvod vode iz krila 360.009	Insert for sash drainage 360.009		2	
Odbojnik na krilu 345.010	Sash bumper 345.010		2	
Pvc profil 374.083	Pvc profile 374.083	MH-63.5	1	90-90
Pvc profil 374.083	Pvc profile 374.083	MH-87	1	90-90
Brtva krila 327.003	Sash gasket 327.003		2Lkr+2Hkr	
Brtva u gornjem horiz. pojasu krila 348.067	Upper horiz. sash zone gasket 348.067		Lkr	
Brtva u gornjem horiz. pojasu krila 348.109 <sup>X</sup>	Upper horiz. sash zone gasket 348.109 <sup>X</sup>		Lkr	
Brtva u donjem pojasu krila 348.079	Lower sash zone gasket 348.079		Lkr	
Brtva u pragu ispod krila 348.061	Under sash threshold gasket 348.061	ML-79	1	90-90
Brtva u pragu u fiksnom dijelu 348.081	Threshold gasket-fixed part 348.081	Lpreč-78	1	90-90
Brtva ispod maske u pragu 344.080	Threshold gask. under mask 344.080	ML-Lpreč-48	1	90-90
Brtva na spoju krila i fiksnog 344.113	Gasket on sash-fixed joint 344.113	MH-63.5	1	90-90
Brtva na spoju krila i fiksnog 344.113	Gasket on sash-fixed joint 344.113	MH-87	1	90-90
Brtva prema staklu /vanjska/ 328.002	Gasket to the glass /exterior/ 328.002		2Lkr+2Hkr+2Lfix+2MH	
Brtva prema staklu /unutarnja/ 311.004	Gasket to the glass /interior/ 311.004		2Lkr+2Hkr+2Lfix+2MH	
Brtva 347.012	Gasket 347.012		(ML/2)+3MH+2Hkr	
Izolacijski umetak po obodu stakla 340.013	Insulation insert along glass edge 340.013		2(Lkr-132)+2(Hkr-156)	
Izolacijski umetak 340.130	Insulation insert 340.130		+2(Lpreč-94)+2(MH-83)	
Izolacijski umetak 340.131	Insulation insert 340.131		Hkr	
Izolacijski umetak 340.129	Insulation insert F-1537 340.129		Hkr	
Umetak na spoju dva krila 340.136	Insert on two sash joint-brushes 340.136		ML-Lpreč-37	

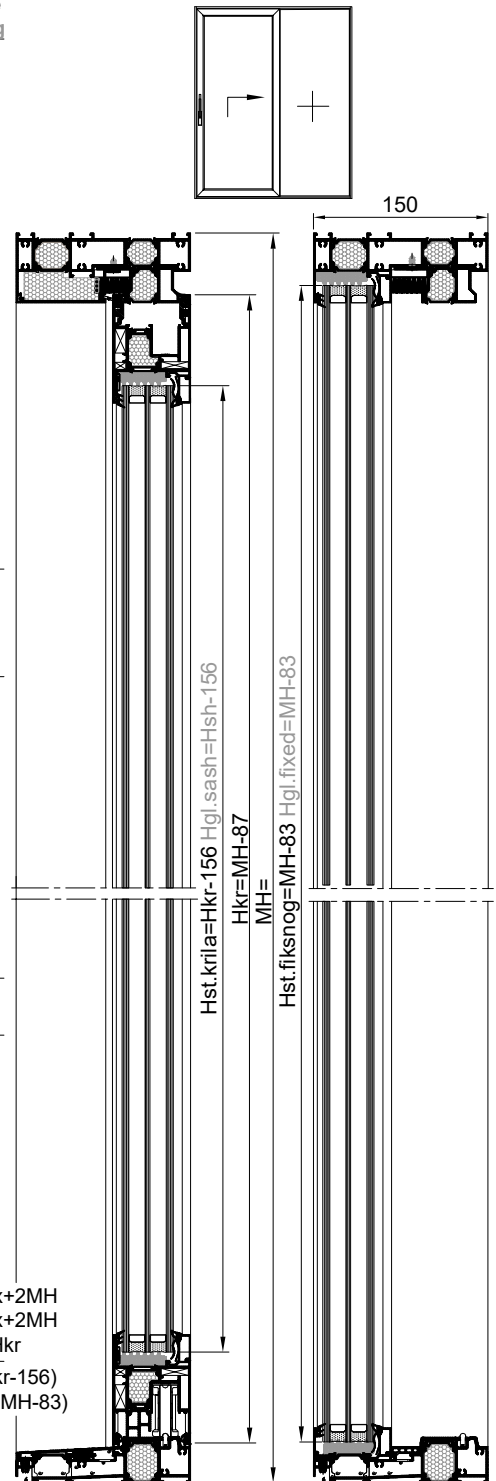

Izbor okova i ručaka za podizno klizni mehanizam 406.08.06  
X-brtva-opcija (za pozicije izložene udarima padalina)

Selection of hardware and handles for L&S hardware 406.08.06  
X-gasket-options (for positions exposed to rainfall)

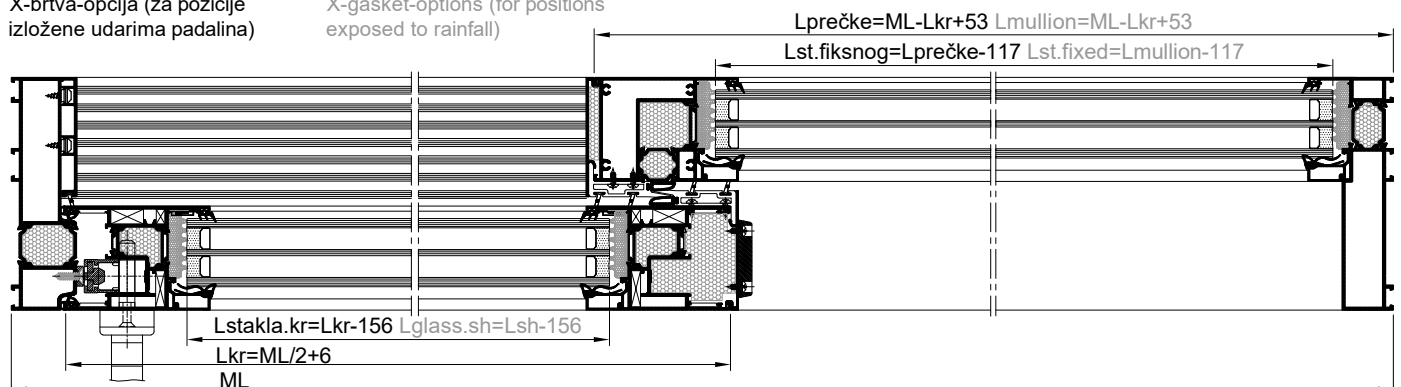

naziv name	mjera measure	kom. pcs.	pilanje cutting
FOkomicna rama FT-1100	Frame vertical FT-1100	MH	1 90-90
Okomicna rama FT-1103F	Frame vertical FT-1103	MH	1 90-90
Vodoravnica rama-donja FT-1102F	Frame horizontal-lower FT-1102F	ML-70	1 90-90
Vodoravnica rama-gornja FT-1101F	Frame horizontal-upper FT-1101F	ML-65	1 90-90
Krilo FT-1120F	Sash FT-1120F	ML/2+29.5*	2 45-45
Krilo FT-1120F	Sash FT-1120F	MH-87	1 45-45
Krilo FT-1121F	Sash FT-1121F	MH-183	1 45-45
Prečka FT-1130F	Mullion FT-1130F	MH-66	1 90-90
Umetak rama FT-1132F	Frame insert FT-1132F	ML-79	1 90-90
Maska F-1538	Mask F-1538	MH-63.5	1 90-90
Maska F-1538	Mask F-1538	MH-87	1 90-90
Maska praga F-1536	Threshold mask F-1536	ML-Lpreč.-37.5	1 90-90
Maska praga F-1418	Threshold mask F-1418	ML-59	1 90-90
Vanjska st lajsna F-1419	Exterior glazing bead F-1419	Lpreč-99.5	1 90-90
Al vodilica F-1112 (elox)	Al guide F-1112 (elox)	ML-85	1 90-90
Maska F-1537	Mask F-1537	ML-Lpreč.-37	1 90-90
Maska F-1434	Mask F-1434	MH-85	1 90-90
Staklo lajsna Z40-664	Glazing bead Z40-664	Lkr-94	2 90-90
Staklo lajsna Z40-664	Glazing bead Z40-664	Hkr-186	2 90-90
Staklo lajsna Z40-664	Glazing bead Z40-664	Lprečke-56	2 90-90
Staklo lajsna Z40-664	Glazing bead Z40-664	MH-107	2 90-90
Kutna spojnica 710.402	Corner bracket 710.402		2
Kutna spojnica 710.401	Corner bracket 710.401		2
Kutna spojnica 710.403	Corner bracket 710.403		2
Kutna spojnica 710.404	Corner bracket 710.404		2
Kutna spojnica 731.010	Corner bracket 731.010		4
Kutna spojnica 730.017	Corner bracket 730.017		4
Čep za donji spoj rama 373.070	Cap for lower frame joint 373.070		1
Čep za gornji spoj rama 373.071	Cap for upper frame joint 373.071		1
Čep maske krila donji 373.051	Cap mask on sash-lower 373.051		1
Čep maske krila gornji 373.053	Cap mask on sash-upper 373.053		1
Usmjerivač krila 373.078	Sash guide 373.078		4
Čep za gornji spoj rama 363.056 (lijevi)	Cap for upper frame joint 363.056 (lft)		1
Čep za donji spoj rama 363.058 (lijevi)	Cap for lower frame joint 363.058 (lft)		1
Umetak za odvod vode iz krila 360.009	Insert for sash drainage 360.009		2
Odbojnik na krilu 345.010	Sash bumper 345.010		2
Čep profila malog krila FT-1121 363.052	Cap of small sash profile FT-1121 363.052		1 par
Čep prečke 363.053	Mullion cap 363.053		1
Čep prečke 373.069	Mullion cap 373.069		1
Pvc profil 374.120	Pvc profile 374.120	MH-63.5	1 90-90
Pvc profil 374.120	Pvc profile 374.120	MH-87	1 90-90
Brtva krila 327.003	Sash gasket 327.003		2Lkr+2Hkr
Brtva u gornjem horiz. pojasu krila 348.067	Upper horiz. sash zone gasket 348.067	Lkr	
Brtva u gornjem horiz. pojasu krila 348.109 <sup>X</sup>	Upper horiz. sash zone gasket 348.109 <sup>X</sup>	Lkr	
Brtva u donjem pojasu krila 348.079	Lower sash zone gasket 348.079	Lkr	
Brtva u pragu ispod krila 348.061	Under sash threshold gask. 348.061	ML-79	1 90-90
Brtva u pragu u fiks. dijelu 348.081	Threshold gask.-fixed part 348.081	Lpreč-56	1 90-90
Brtva ispod maske u pragu 344.080	Threshold ga. under mask 344.080	ML-Lpreč-48	1 90-90
Brtva na spoju krila i fiksnog 344.113	Gasket on sash-fixed joint 344.113	MH-63.5	1 90-90
Brtva na spoju krila i fiksnog 344.113	Gasket on sash-fixed joint 344.113	MH-87	1 90-90
Brtva prema staklu /vanj./ 328.002	Gasket to the glass/exterior/ 328.002		2Lkr+2Hkr+2Lfix+2MH
Brtva prema staklu /unut./ 311.004	Gasket to the glass/interior/ 311.004		2Lkr+2Hkr+2Lfix+2MH
Brtva 347.012	Gasket 347.012		(ML/2)+3MH+2Hkr
Izolacijski umetak po obodu stakla 340.013	Insulation insert along glass edge 340.013		2(Lkr-86)+2(Hkr-156) +2(Lpreč-46)+2(MH-83)
Izolacijski umetak 340.131	Insulation insert 340.131		2Hkr
Izolacijski F-1537 340.129	Insulation insert F-1537 340.129		ML-Lpreč-37
Umetak na spoju dva krila- 340.137	Insert on two sash joint-brushes 340.137		1
Izbor okova i ručaka za podizno klizni mehanizam 406.08.06	Selection of hardware and handles for L&S hardware 406.08.06		
X-brtva-opcija (za pozicije izložene udarima padalina)	X-gasket-options (for positions exposed to rainfall)		

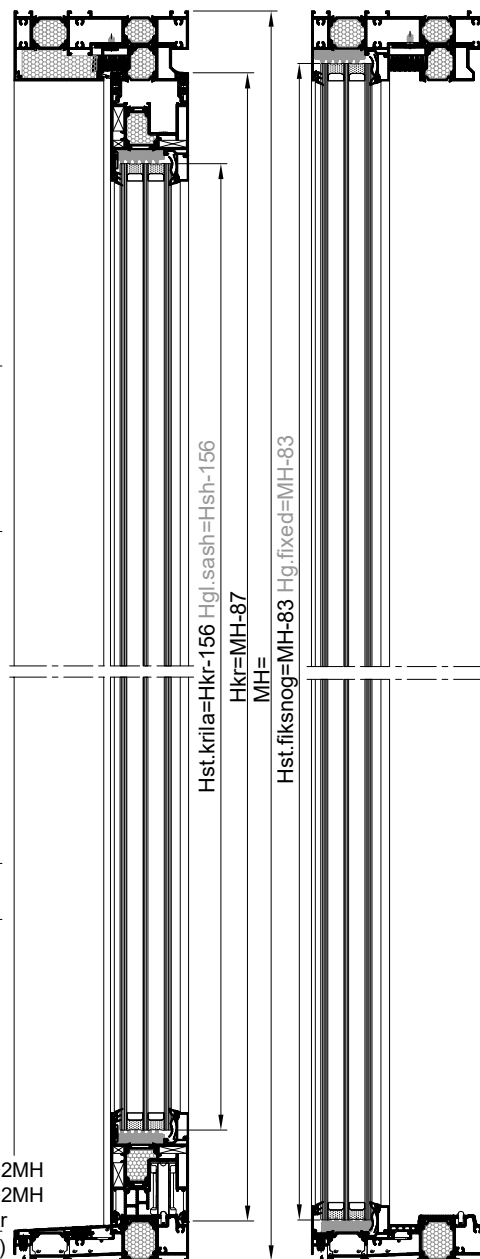
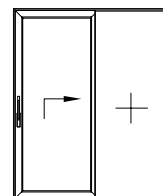

\*VIDJET STRANICU KATALOGA 406.11.111  
SEE PAGE 406.11.111

Lprečke=ML-Lkr+5 Lmullion=ML-Lkr+5  
Lst.fiksnog=Lprečke-69 Lgl.fixed=Lmullion-69

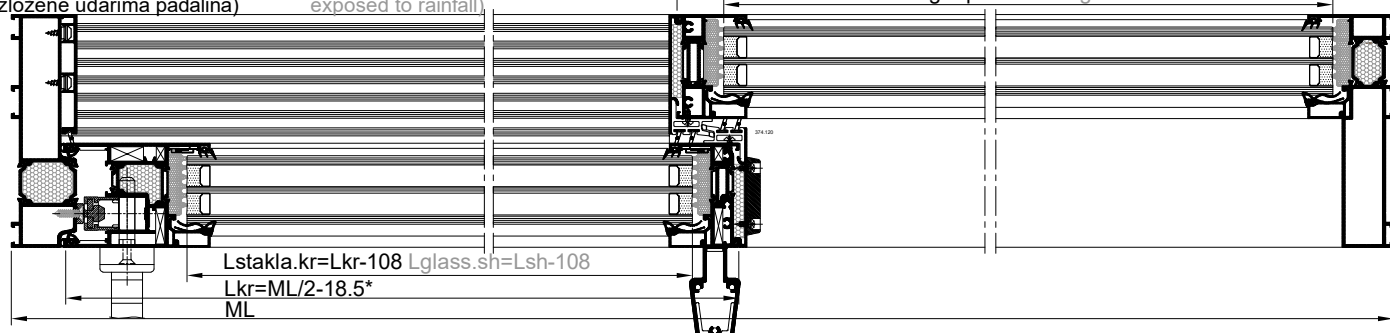

naziv name	mjera measure	kom. pcs.	pilanje cutting
Okomica rama FT-1100F	Frame vertical FT-1100F	MH	2
Vodoravnica rama-donja FT-1102F	Frame horizontal-lower FT-1102F	ML-64	1
Vodoravnica rama-gornja FT-1101F	Frame horizontal-upper FT-1101F	ML-64	1
Krilo FT-1120F	Sash FT-1120F	ML/4+22	4
Krilo FT-1120F	Sash FT-1120F	MH-87	4
Prečka FT-1131F	Mullion FT-1131F	MH-85	2
Umetak rama FT-1132F	Frame insert FT-1132F	ML-94	1
Maska F-1538	Mask F-1538	MH-63.5	2
Maska F-1538	Mask F-1538	MH-87	2
Maska praga F-1536	Threshold mask F-1536	Lpreč.-37.5	2
Maska praga F-1418	Threshold mask F-1418	ML-64	1
Vanjska st lajsna F-1419	Exterior glazing bead F-1419	ML-2Lpreč.-186	1
Al vodilica F-1112 (elox)	Al guide F-1112 (elox)	ML-94	1
Maska F-1537	Mask F-1537	Lpreč.-37	2
Maska F-1434	Mask F-1434	MH-85	2
Staklo lajsna Z40-664	Glazing bead Z40-664	Lkr-142	4
Staklo lajsna Z40-664	Glazing bead Z40-664	Hkr-186	4
Staklo lajsna Z40-664	Glazing bead Z40-664	ML-2Lpreč-142	2
Staklo lajsna Z40-664	Glazing bead Z40-664	MH-107	2
Kutna spojnica 710.401	Corner bracket 710.401		8
Kutna spojnica 710.403	Corner bracket 710.403		8
Kutna spojnica 731.010	Corner bracket 731.010		8
Kutna spojnica 730.017	Corner bracket 730.017		16
Čep maske krila donji 373.051 (lijevi)	Cap mask on sash-lower 373.051 (ft.)		1
Čep maske krila donji 373.052 (desni)	Cap mask on sash-upper 373.052 (rg.)		1
Čep maske krila gornji 373.053	Sash mask cap - upper 373.053		2
Usmjerivač krila 373.078	Sash guide 373.078		8
Čep za gornji spoj rama 363.056 (lijevi)	Cap for upper frame joint 363.056 (ft.)		1
Čep za gornji spoj rama 363.057 (desni)	Cap for upper frame joint 363.057 (rg.)		1
Čep za donji spoj rama 363.058 (lijevi)	Cap for lower frame joint 363.058 (ft.)		1
Čep za donji spoj rama 363.059 (desni)	Cap for lower frame joint 363.059 (rg.)		1
Čep prečke donji 373.067	Mullion cap-lower 373.067		1
Čep prečke gornji 373.068	Mullion cap-upper 373.068		1
Čep prečke donji 373.072	Mullion cap-lower 373.072		1
Čep prečke gornji 373.073	Mullion cap-upper 373.073		1
Umetak za odvod vode iz krila 360.009	Insert for sash drainage 360.009		4
Odbojnik na krilu 345.010	Sash bumper 345.010		4
Pvc profil 374.083	Pvc profile 374.083	MH-63.5	2
Pvc profil 374.083	Pvc profile 374.083	MH-87	2
Brtva krila 327.003	Sash gasket 327.003		4Lkr+4Hkr
Brtva u gor.horiz. pojasu krila 348.067	Upper horiz. sash zone gasket 348.067		2 Lkr
Brtva u gor.horiz. pojasu krila 348.109 <sup>x</sup>	Upper horiz. sash zone gasket 348.109 <sup>x</sup>		2 Lkr
Brtva u donjem pojasu krila 348.079	Lower sash zone gasket 348.079		2Lkr
Brtva u pragu ispod krila 348.061	Under sash threshold gas. 348.061	ML-94	1
Brtva u pragu u fiks. dijelu 348.081	Threshold gask.-fixed part 348.081	ML-2Lpreč-100	1
Brtva ispod maske u pragu 344.080	Threshold gask. under mask 344.080	Lpreč-48	2
Brtva na spoju krila i fik. 344.113	Gasket on sash-fixed joint 344.113	MH-63.5	2
Brtva na spoju krila i fik. 344.113	Gasket on sash-fixed joint 344.113	MH-87	2
Brtva prema staklu/vanji./ 328.002	Gasket to the glass /exterior/ 328.002		4Lkr+4Hkr+2Lfix+2MH
Brtva prema staklu /unut./ 311.004	Gasket to the glass /interior/ 311.004		4Lkr+4Hkr+2Lfix+2MH
Četkasta brtva 347.012	Brush gasket 347.012		(ML/2)+6MH+4Hkr
Izolacijski umetak po obodu stakla 340.013	Insulation insert along glass edge 340.013		4(Lkr-132)+4(Hkr-156) + 2(ML-2Lpreč-132)+2(MH-83)
Izolacijski umetak 340.130	Insulation insert 340.130		2Hkr
Izolacijski umetak 340.131	Insulation insert 340.131		2Hkr
Izolacijski umetak 340.129	Insulation insert 340.129		2(Lpreč-37)
Umetak na spoju dva krila-340.136	Insert on two sash joint-brushes 340.136		2
Izbor okova i ručaka za podizno klizni mehanizam 406.08.06	Selection of hardware and handles for L&S hardware 406.08.06		

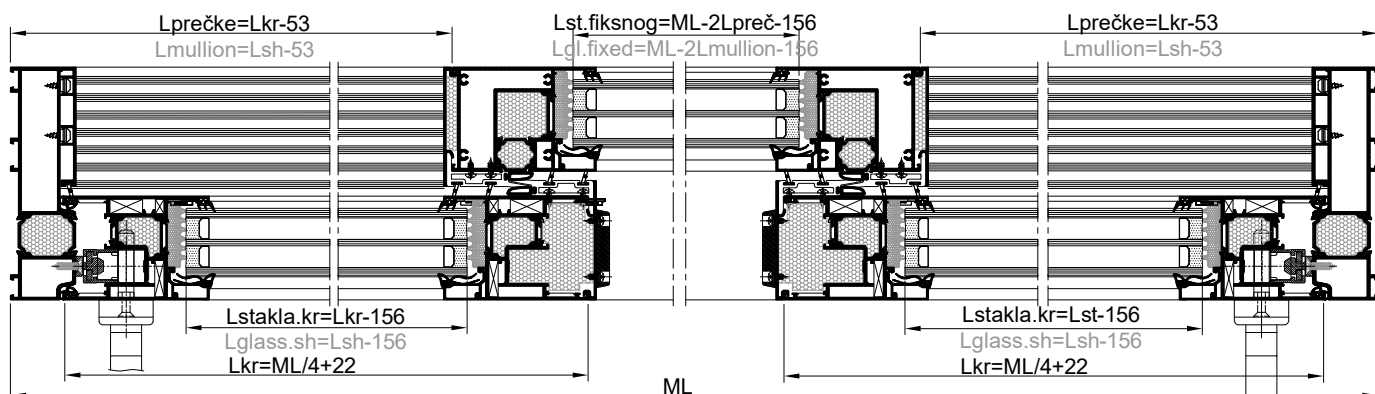
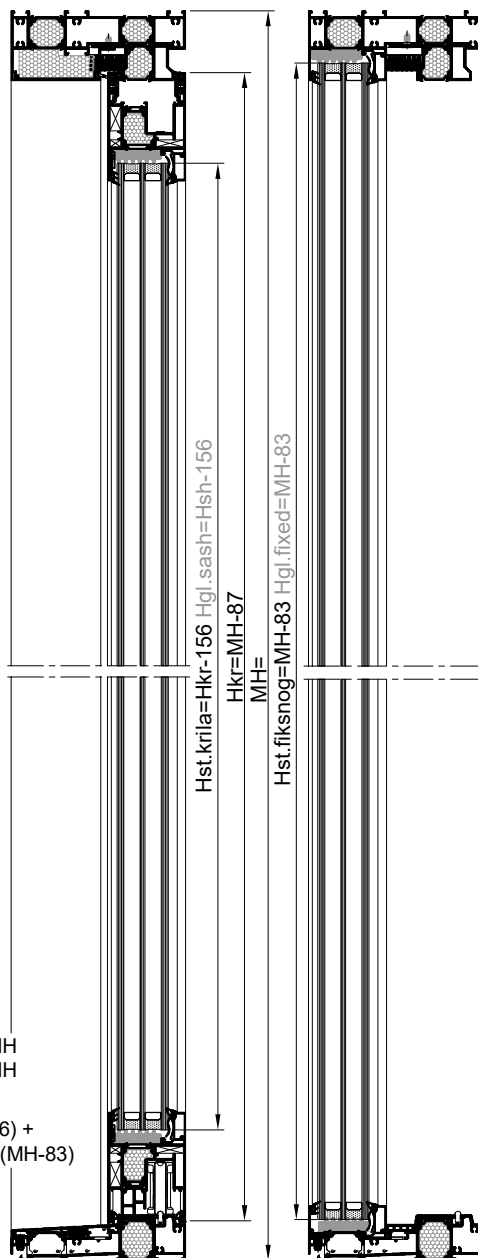
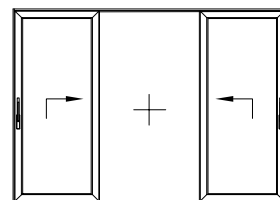

naziv name	mjera measure	kom. pcs.	pilanje cutting	
Okomica rama FT-1100F	Frame vertical FT-1100	MH	2	90-90
Vodoravnica rama-donja FT-1102F	Frame horizontal-lower FT-1102F	ML-64	1	90-90
Vodoravnica rama-gornja FT-1101F	Frame horizontal-upper FT-1101F	ML-64	1	90-90
Krilo FT-1120F	Sash FT-1120F	(ML/4)+46 *	4	45-45
Krilo FT-1120F	Sash FT-1120F	MH-87	2	45-45
Krilo FT-1121F	Sash FT-1121F	MH-183	2	45-45
Prečka FT-1130F	Mullion FT-1131F	MH-66	2	90-90
Umetak rama FT-1132F	Frame insert FT-1132F	ML-94	1	90-90
Maska F-1538	Mask F-1538	MH-63.5	2	90-90
Maska F-1538	Mask F-1538	MH-87	2	90-90
Maska praga F-1536	Treshold mask F-1536	Lpreč.-37.5	2	90-90
Maska praga F-1418	Treshold mask F-1418	ML-64	1	90-90
Vanjska st lajsna F-1419	Exterior glazing bead F-1419	ML-2Lpreč.-90	1	90-90
Al vodilica F-1112 (elox)	Al guide F-1112 (elox)	ML-94	1	90-90
Maska F-1537	Mask F-1537	Lpreč.-37	2	90-90
Maska F-1434	Mask F-1434	MH-85	2	90-90
Staklo lajsna Z40-664	Glazing bead Z40-664	Lkr-94	4	90-90
Staklo lajsna Z40-664	Glazing bead Z40-664	Hkr-186	4	90-90
Staklo lajsna Z40-664	Glazing bead Z40-664	ML-2Lpreč-46	2	90-90
Staklo lajsna Z40-664	Glazing bead Z40-664	MH-107	2	90-90
Kutna spojnica 710.402	Corner bracket 710.402		4	
Kutna spojnica 710.401	Corner bracket 710.401		4	
Kutna spojnica 710.403	Corner bracket 710.403		4	
Kutna spojnica 710.404	Corner bracket 710.403		4	
Kutna spojnica 731.010	Corner bracket 731.010		8	
Kutna spojnica 730.017	Corner bracket 730.017		8	
Čep maske krila donji 373.051 (lijevi)	Cap mask on sash-lower 373.051 (lft.)		1	
Čep maske krila donji 373.052 (desni)	Cap mask on sash-upper 373.052 (rgh.)		1	
Čep maske krila gornji 373.053	Sash mask cap - upper 373.053		2	
Usmjerivač krila 373.078	Sash guide 373.078		8	
Čep za gornji spoj rama 363.056 (lijevi)	Cap for upper frame joint 363.056 (lft.)		1	
Čep za gornji spoj rama 363.057 (desni)	Cap for upper frame joint 363.057 (rgh.)		1	
Čep za donji spoj rama 363.058 (lijevi)	Cap for lower frame joint 363.058 (lft.)		1	
Čep za donji spoj rama 363.059 (desni)	Cap for lower frame joint 363.059 (rgh.)		1	
Umetak za odvod vode iz krila 360.009	Insert for sash drainage 360.009		4	
Odbojnik na krilu 345.010	Sash bumper 345.010		4	
Čep profila krila FT-1121 363.052	Cap for sash profile FT-1121 363.052		2 par	
Čep prečke 363.053 (lijevi)	Mullion cap 363.053 (lft.)		1	
Čep prečke 363.054 (desni)	Mullion cap 363.054 (rgh.)		1	
Čep prečke gornji 373.069	Mullion cap upper 373.069		1	
Čep prečke gornji 373.074	Mullion cap upper 373.074		1	
Pvc profil 374.120	Pvc profile 374.120	MH-63.5	2	90-90
Pvc profil 374.120	Pvc profile 374.120	MH-87	2	90-90
Brtva krila 327.003	Sash gasket 327.003		4Lkr+4Hkr	
Brtva u gornj. horiz. pojasu krila 348.067	Upper horiz. sash zone gasket 348.067		2 Lkr	
Brtva u gornj. horiz. pojasu krila 348.109 <sup>X</sup>	Upper horiz. sash zone gasket 348.109 <sup>X</sup>		2 Lkr	
Brtva u donjem pojasu krila 348.079	Lower sash zone gasket 348.079		2Lkr	
Brtva u pragu ispod krila 348.061	Under sash treshold gas. 348.061	ML-94	1	90-90
Brtva u pragu u fiks. dijelu 348.081	Treshold gask.-fixed part 348.081	ML-2Lpreč-46	1	90-90
Brtva ispod maske u pragu 344.080	Treshold gask. under mask 344.080	Lpreč-48	2	90-90
Brtva na spoju krila i fiksnog 344.113	Gasket on sash-fixed joint 344.113	MH-63.5	2	90-90
Brtva na spoju krila i fiksnog 344.113	Gasket on sash-fixed joint 344.113	MH-87	2	90-90
Brtva prema staklu /vanjska/ 328.002	Gasket to the glass /exterior/ 328.002		4Lkr+4Hkr+2Lfix+2MH	
Brtva prema staklu /unut./ 311.004	Gasket to the glass /interior/ 311.004		4Lkr+4Hkr+2Lfix+2MH	
Brtva 347.012	Gasket 347.012		(ML/2)+6MH+4Hkr	
Izolacijski umetak 340.013	Insulation insert 340.013		4(Lkr-86)+4(Hkr-156) +2(ML-2Lpreč-36)+2(MH-83)	
Izolacijski umetak 340.131	Insulation insert 340.131		4Hkr	
Izolacijski umetak 340.129	Insulation insert 340.129		2(Lpreč-37)	
Umetak na spoju dva krila- 340.137	Insert on two sash joint-brushes 340.137		2	

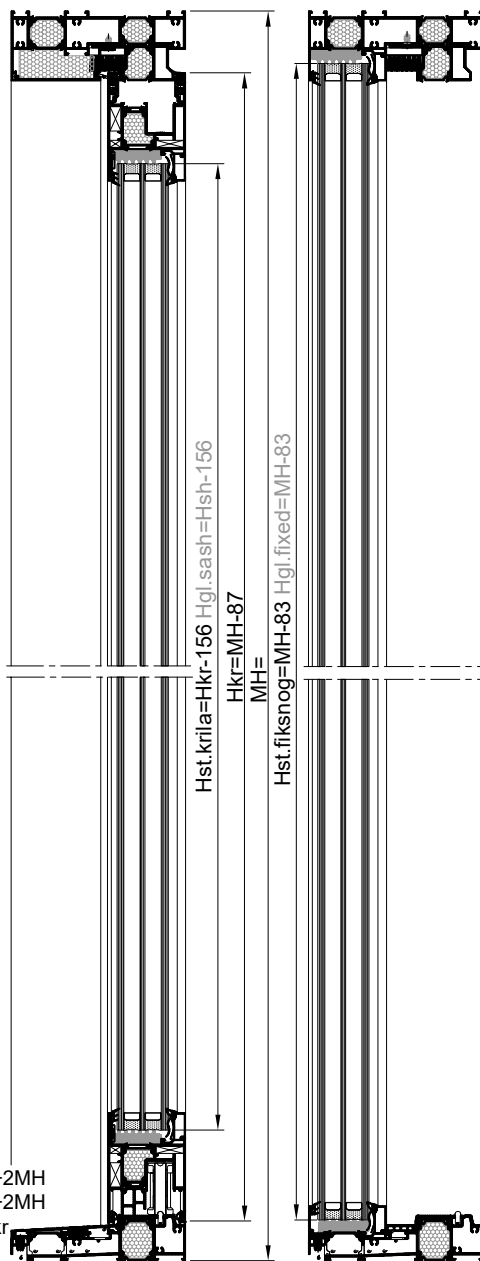
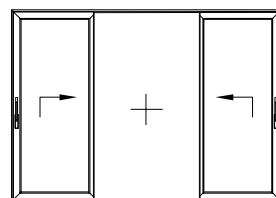

VIDJET STRANICU KATALOGA 406.11.117  
\* SEE PAGE 406.11.117

Izbor okova i ručaka za podizno klizni mehanizam 406.08.06 Selection of hardware and handles for L&S hardware 406.08.06

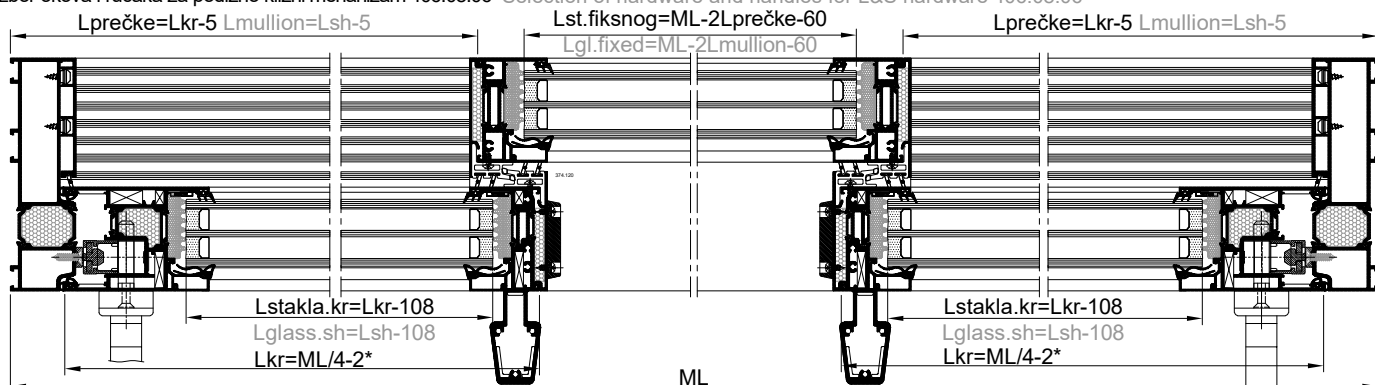

naziv name	mjera measure	kom. pcs.	pilanje cutting
Okomica rama FT-1103F	Frame vertical FT-1103F	MH	2 90-90
Vodoravnica rama-donja FT-1102F	Frame horizontal-lower FT-1102F	ML-76	1 90-90
Vodoravnica rama-gornja FT-1101F	Frame horizontal-upper FT-1101F	ML-66	1 90-90
Krilo FT-1120F	Sash FT-1120F	ML/4+22	4 45-45
Krilo FT-1120F	Sash FT-1120F	MH-87	4 45-45
Prečka FT-1131F	Mullion FT-1131F	MH-85	2 90-90
Umetak rama FT-1132F	Frame insert FT-1132F	ML-64	1 90-90
Umetak krila FT-1030F	Frame insert FT-1030F	MH-87	1 90-90
Maska F-1538	Mask F-1538	MH-63.5	2 90-90
Maska F-1538	Mask F-1538	MH-87	2 90-90
Maska praga F-1536	Treshold mask F-1536	ML-2Lpreč-10	1 90-90
Maska praga F-1418	Treshold mask F-1418	ML-108	1 90-90
Vanjska st lajsna F-1419	Exterior glazing bead F-1419	Lpreč-148	2 90-90
Al vodilica F-1112 (elox)	Al guide F-1112 (elox)	ML-76	1 90-90
Maska F-1537	Mask F-1537	ML-2Lpreč-10	1 90-90
Staklo lajsna Z40-664	Glazing bead Z40-664	Lkr-142	4 90-90
Staklo lajsna Z40-664	Glazing bead Z40-664	Hkr-186	4 90-90
Staklo lajsna Z40-664	Glazing bead Z40-664	Lpreč-104	4 90-90
Staklo lajsna Z40-664	Glazing bead Z40-664	MH-107	4 90-90
Kutna spojnica 710.401	Corner bracket 710.401		8
Kutna spojnica 710.403	Corner bracket 710.403		8
Kutna spojnica 731.010	Corner bracket 731.010		8
Kutna spojnica 730.017	Corner bracket 730.017		16
Čep maske krila donji 373.051 (lijevi)	Cap mask on sash-lower 373.051 (lft.)		1
Čep maske krila donji 373.052 (desni)	Cap mask on sash-upper 373.052 (rgh.)		1
Čep maske krila gornji 373.053	Sash mask cap - upper 373.053		2
Usmjerivač krila 373.078	Sash guide 373.078		8
Čep za profil FT-1030 363.030	Cap for profile FT-1030 363.030		1 par
Čep prečke donji 373.067	Mullion cap-lower 373.067		1
Čep prečke gornji 373.068	Mullion cap-upper 373.068		1
Čep za donji spoj rama 373.070	Cap for lower frame joint 373.070		1
Čep za gornji spoj rama 373.071	Cap for upper frame joint 373.071		1
Čep prečke donji 373.072	Mullion cap-lower 373.072		1
Čep prečke gornji 373.073	Mullion cap-upper 373.073		1
Čep za donji spoj rama 373.075	Cap for lower frame joint 373.075		1
Čep za gornji spoj rama 373.076	Cap for upper frame joint 373.076		1
Umetak za odvod vode iz krila 360.009	Insert for sash drainage 360.009		4
Odbojnik na krilu 345.010	Sash bumper 345.010		4
Pvc profil 374.083	Pvc profile 374.083	MH-63.5	2 90-90
Pvc profil 374.083	Pvc profile 374.083	MH-87	2 90-90
Brtva krila 327.003	Sash gasket 327.003		2Lkr+2Hkr
Brtva u gornj. horiz.pojasu krila 348.067	Upper horizontal sash zone gasket 348.067		2 Lkr
Brtva u gornj. horiz.pojasu krila 348.109 <sup>X</sup>	Upper horizontal sash zone gasket 348.109 <sup>X</sup>		2 Lkr
Brtva u donjem pojasu krila 348.079	Lower sash zone gasket 348.079		2Lkr
Brtva u pragu ispod krila 348.061	Under sash treshold gas. 348.061	ML-66	1 90-90
Brtva u pragu u fiksnom dijelu 348.081	Treshold gask.-fixed part 348.081	Lpreč-88	2 90-90
Brtva ispod maske u pragu 344.080	Treshold gask. under mask 344.080	ML-2Lpreč.-10	1 90-90
Brtva na spoju krila i fiksnog 344.113	Gasket on sash-fixed joint 344.113	MH-63.5	2 90-90
Brtva na spoju krila i fiksnog 344.113	Gasket on sash-fixed joint 344.113	MH-87	2 90-90
Brtva prema staklu /vanjska/ 328.002	Gasket to the glass /exterior/ 328.002		4Lkr+4Hkr+4Lfix+4MH
Brtva prema staklu /unutarnja/ 311.004	Gasket to the glass /interior/ 311.004		4Lkr+4Hkr+4Lfix+4MH (ML/2)+4MH+4Hkr
Brtva 347.012	Gasket 347.012		
Izolacijski umetak po obodu stakla 340.013	Insulation insert along glass edge 340.013		4(Lkr-132)+4(Hkr-156) +4(Lpreč-94)+4(MH-83)
Izolacijski umetak 340.130	Insulation insert 340.130		2Hkr
Izolacijski umetak 340.131	Insulation insert 340.131		2Hkr
Izolacijski umetak 340.129	Insulation insert 340.129		ML-2Lpreč-10
Umetak na spoju dva krila- 340.136	Insert on two sash joint-brushes 340.136		2
Izbor okova i ručaka za podizno klizni mehanizam 406.08.06	Selection of hardware and handles for L&S hardware 406.08.06		

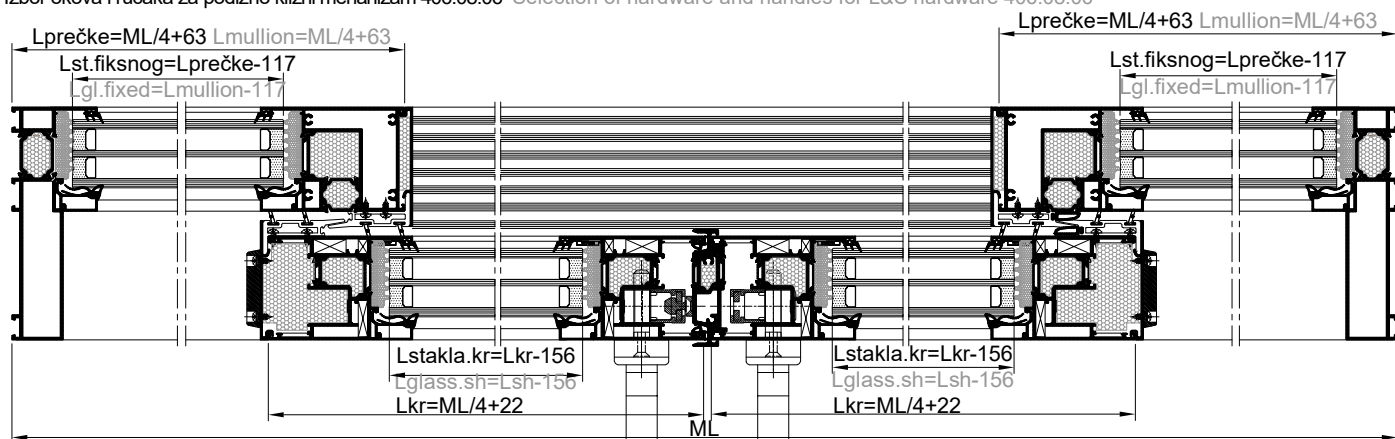
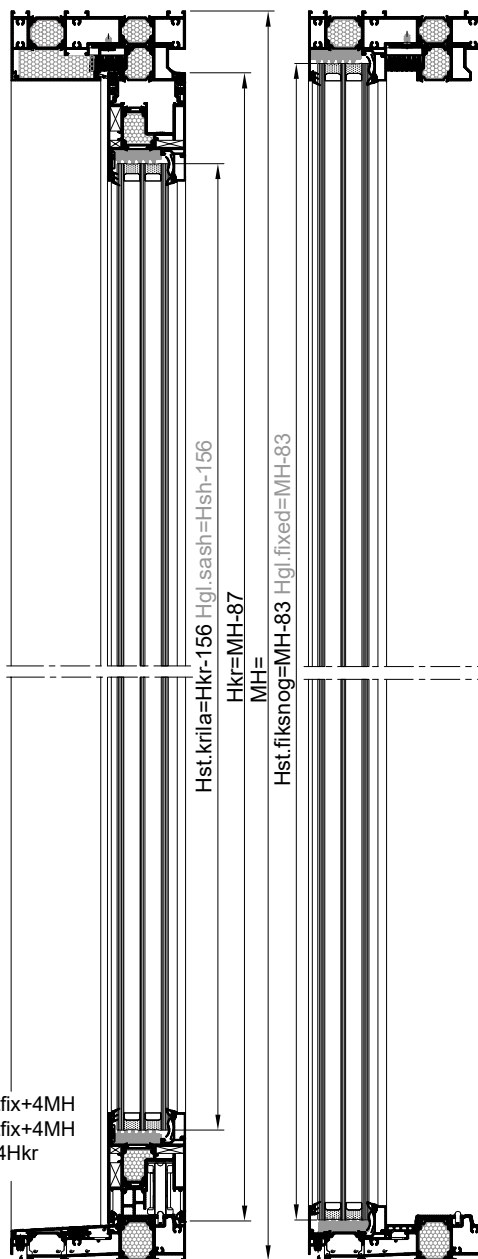
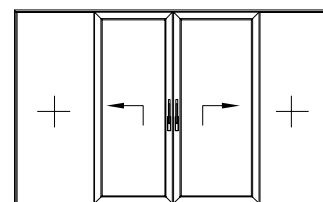

naziv name	mjera measure	kom. pcs.	pilanje cutting
Okomica rama FT-1103F	Frame vertical FT-1103F	MH	2 90-90
Vodoravnica rama-donja FT-1102F	Frame horizontal-lower FT-1102F	ML-76	1 90-90
Vodoravnica rama-gornja FT-1101F	Frame horizontal-upper FT-1101F	ML-66	1 90-90
Krilo FT-1120F	Sash FT-1120F	(ML/4)+46*	4 45-45
Krilo FT-1120F	Sash FT-1120F	MH-87	2 45-45
Krilo FT-1121F	Sash FT-1121F	MH-183	2 45-90
Prečka FT-1130F	Mullion FT-1130F	MH-66	2 90-90
Umetak rama FT-1132F	Frame insert FT-1132F	ML-64	1 90-90
Umetak krila FT-1030F	Frame insert FT-1030F	MH-87	1 90-90
Maska F-1538	Mask F-1538	MH-63.5	2 90-90
Maska F-1538	Mask F-1538	MH-87	2 90-90
Maska praga F-1536	Threshold mask F-1536	ML-2Lpreč-10	1 90-90
Maska praga F-1418	Threshold mask F-1418	ML-108	1 90-90
Vanjska st lajsna F-1419	Exterior glazing bead F-1419	Lpreč-100	2 90-90
Al vodilica F-1112 (elox)	Al guide F-1112 (elox)	ML-76	1 90-90
Maska F-1537	Mask F-1537	ML-2Lpreč-10	1 90-90
Staklo lajsna Z40-664	Glazing bead Z40-664	Lkr-94	4 90-90
Staklo lajsna Z40-664	Glazing bead Z40-664	Hkr-186	4 90-90
Staklo lajsna Z40-664	Glazing bead Z40-664	Lpreč-56	4 90-90
Staklo lajsna Z40-664	Glazing bead Z40-664	MH-107	4 90-90
Kutna spojnica 710.402	Corner bracket 710.402		4
Kutna spojnica 710.401	Corner bracket 710.401		4
Kutna spojnica 710.403	Corner bracket 710.403		4
Kutna spojnica 710.404	Corner bracket 710.404		4
Kutna spojnica 731.010	Corner bracket 731.010		8
Kutna spojnica 730.017	Corner bracket 730.017		8
Čep maske krila donji 373.051 (lijevi)	Cap mask on sash-lower 373.051 (left)		1
Čep maske krila donji 373.052 (desni)	Cap mask on sash-lower 373.052 (right)		1
Čep maske krila gornji 373.053	Cap mask on sash-upper 373.053		2
Usmjerivač krila 373.078	Sash guide 373.078		8
Umetak za odvod vode iz krila 360.009	Insert for sash drainage 360.009		4
Odbojnik na krilu 345.010	Sash bumper 345.010		4
Čep profila malog krila FT-1121 363.052	Cap for small sash profile FT-1121 363.052		2 par
Čep prečke 363.053 (lijevi)	Mullion cap 363.053 (left)		1
Čep prečke 363.054 (desni)	Mullion cap 363.054 (right)		1
Čep za profil FT-1030 363.030	Profile cap FT-1030 363.030		1 par
Čep prečke gornji 373.069	Mullion cap-upper 373.069		1
Čep za donji spoj rama 373.070	Cap for lower frame joint 373.070		1
Čep za gornji spoj rama 373.071	Cap for upper frame joint 373.071		1
Čep prečke gornji 373.074	Mullion cap-upper 373.074		1
Čep za donji spoj rama 373.075	Cap for lower frame joint 373.075		1
Čep za gornji spoj rama 373.076	Cap for upper frame joint 373.076		1
Pvc profil 374.120	Pvc profile 374.120	MH-63.5	2 90-90
Pvc profil 374.120	Pvc profile 374.120	MH-87	2 90-90
Brtva krila 327.003	Sash gasket 327.003		2Lkr+2Hkr
Brtva u gornj.horiz.pojasu krila 348.067	Upper horizontal sash zone gasket 348.067		2 Lkr
Brtva u gornj.horiz.pojasu krila 348.109 <sup>X</sup>	Upper horizontal sash zone gasket 348.109 <sup>X</sup>		2 Lkr
Brtva u donjem pojasu krila 348.079	Lower sash zone gasket 348.079		2Lkr
Brtva u pragu ispod krila 348.061	Threshold gask. under mask 348.061	ML-66	1 90-90
Brtva u pragu u fiksnom dijelu 348.081	Threshold gasket-fixed part 348.081	Lpreč-48	2 90-90
Brtva ispod maske u pragu 344.080	Threshold gask. under mask 344.080	ML-2Lpreč.-10	1 90-90
Brtva na spoju krila i fiksnog 344.113	Gasket on sash-fixed joint 344.113	MH-63.5	2 90-90
Brtva na spoju krila i fiksnog 344.113	Gasket on sash-fixed joint 344.113	MH-87	2 90-90
Brtva prema staklu /vanjska/ 328.002	Gasket to the glass /exterior/ 328.002		4Lkr+4Hkr+4Lfix+4MH
Brtva prema staklu /unut./ 311.004	Gasket to the glass /interior/ 311.004		4Lkr+4Hkr+4Lfix+4MH
Brtva 347.012	Gasket 347.012		(ML/2)+4MH+4Hkr
Izolacijski umetak po obodu stakla 340.013	Insulation insert along glass edge 340.013		4(Lkr-86)+4(Hkr-156)
Izolacijski umetak 340.131	Insulation insert 340.131		+4(Lpreč-46)+4(MH-83)
Izolacijski umetak 340.129	Insulation insert 340.129		4Hkr
Umetak na spoju dva krila- 340.137	Insert on two sash joint-brushes 340.137		2

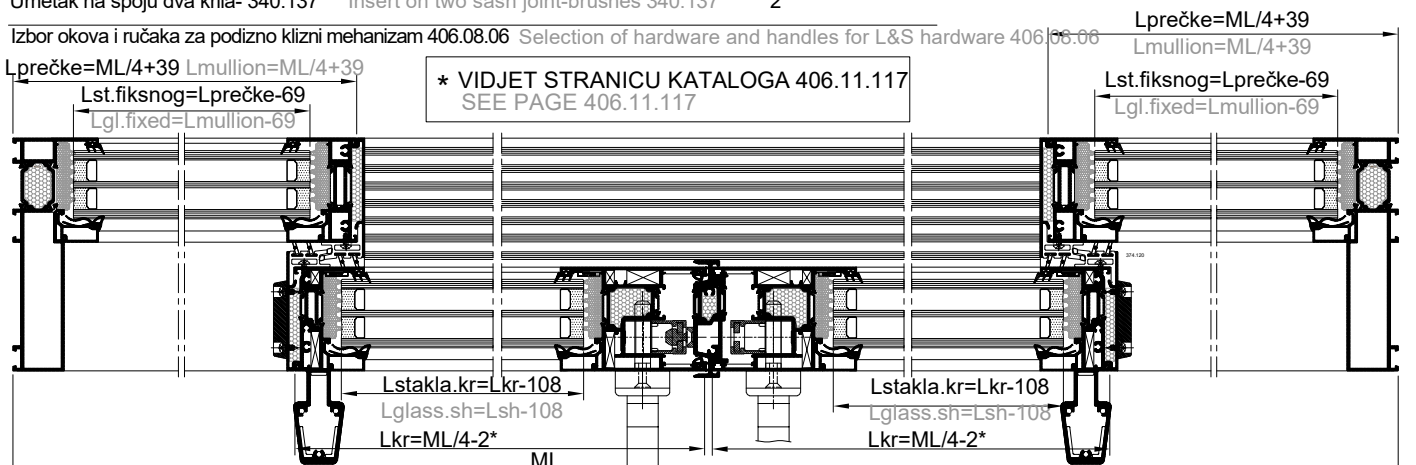
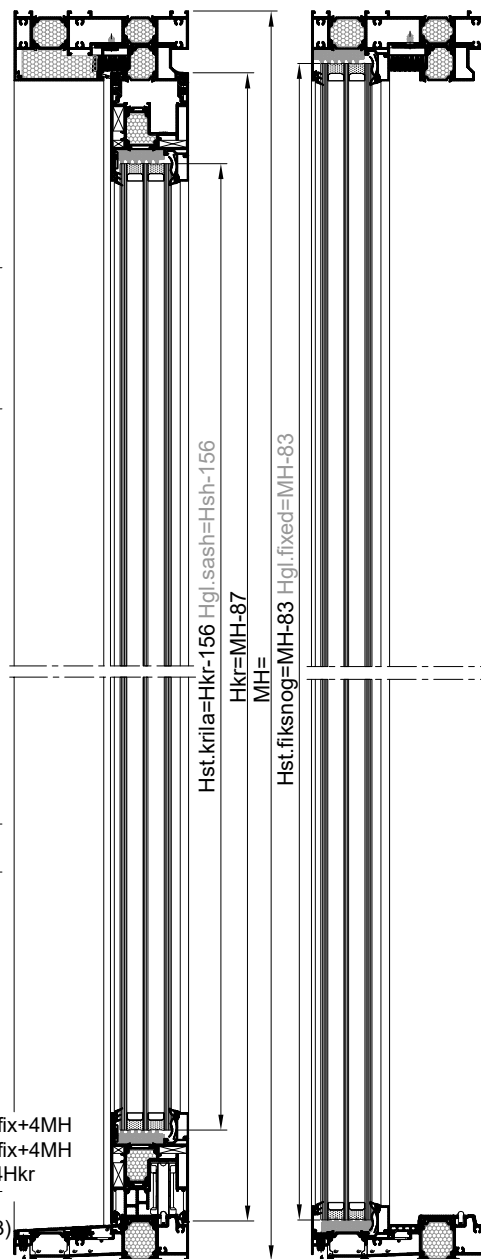
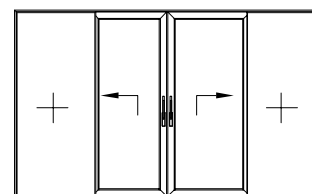

naziv name	mjera measure	kom. pcs.	pilanje cutting	
Okomica rama FT-1103F	Frame vertical FT-1103F	MH	2	90-90
Vodoravnica rama-donja FT-1102F	Frame horizontal-lower FT-1102F	ML-76	1	90-90
Vodoravnica rama-gornja FT-1101F	Frame horizontal-upper FT-1101F	ML-66	1	90-90
Krilo FT-1120F	Sash FT-1120F	ML1/2+8.5	2	45-45
Krilo FT-1120F	Sash FT-1120F	MH-87	2	45-45
Prečka FT-1131F	Mullion FT-1131F	MH-85	1	90-90
Prečka FT-1135F	Mullion FT-1135F	MH-54.5	1	90-90
Umetak rama FT-1132F	Frame insert FT-1132F	ML-(Lprečke1 +43)	1	90-90
Maska F-1538	Mask F-1538	MH-63.5	1	90-90
Maska F-1538	Mask F-1538	MH-87	1	90-90
Maska praga F-1536	Threshold mask F-1536	ML1-Lpreč.-31	1	90-90
Maska praga F-1418	Threshold mask F-1418	ML-59	1	90-90
Vanjska st lajsna F-1419	Exterior glazing bead F-1419	Lpreč.-148	1	90-90
Vanjska st lajsna F-1419	Exterior glazing bead F-1419	Lpreč.1-110	1	90-90
Al vodilica F-1112 (elox)	Al guide F-1112 (elox)	ML1-64	1	90-90
Maska F-1537	Mask F-1537	ML1-Lpreč.-31	1	90-90
Maska F-1542	Mask F-1542	Lpreč.1-59	1	90-90
Maska F-1539	Mask F-1539	MH-80	1	90-90
Maska F-1434	Mask F-1434	MH-85	1	90-90
Staklo lajsna Z40-664	Glazing bead Z40-664	Lkr-142	2	90-90
Staklo lajsna Z40-664	Glazing bead Z40-664	Hkr-186	2	90-90
Staklo lajsna Z40-664	Glazing bead Z40-664	Lpreč-104	2	90-90
Staklo lajsna Z40-664	Glazing bead Z40-664	MH-107	3	90-90
Staklo lajsna Z40-664	Glass glazing bead Z40-664	Lpreč.1-59	2	90-90
Kutna spojnica 710.401	Corner bracket 710.401		4	
Kutna spojnica 710.403	Corner bracket 710.403		4	
Kutna spojnica 731.010	Corner bracket 731.010		4	
Kutna spojnica 730.017	Corner bracket 730.017		8	
Čep maske krila donji 373.051 (lijevi)	Cap mask on sash-lower 373.051 (left)		1	
Čep maske krila gornji 373.053	Cap mask on sash-upper 373.053		1	
Usmjerivač krila 373.078	Sash guide 373.078		4	
Umetak za odvod vode iz krila 360.009	Insert for sash drainage 360.009		2	
Odbojnik na krilu 345.010	Sash bumper 345.010		2	
Čep za donji spoj prečke 363.060	Cap for lower frame joint 363.060		1	
Čep prečke donji 373.067	Mullion cap-lower 373.067		1	
Čep prečke gornji 373.068	Mullion cap-upper 373.068		1	
Čep za donji spoj rama 373.070	Cap for lower frame joint 373.070		1	
Čep za gornji spoj rama 373.071	Cap for upper frame joint 373.071		1	
Čep za donji spoj rama 373.075	Cap for lower frame joint 373.075		1	
Čep za gornji spoj rama 373.076	Cap for upper frame joint 373.076		1	

Pvc profil 374.083	Pvc profile 374.083	MH-63.5	1	90-90
Pvc profil 374.083	Pvc profile 374.083	MH-87	1	90-90
Brtva krila 327.003	Sash gasket 327.003		2Lkr+2Hkr	
Brtva u gornj. horiz. pojasu krila 348.067	Upper horiz. sash zone gasket 348.067		Lkr	
Brtva u gornj. horiz. pojasu krila 348.109 <sup>x</sup>	Upper horiz. sash zone gasket 348.109 <sup>x</sup>		Lkr	
Brtva u donjem pojasu krila 348.079	Lower sash zone gasket 348.079		Lkr	
Brtva u pragu ispod krila 348.061	Under sash threshold gasket 348.061	ML1-74	1	90-90
Brtva u pragu u fiks. dijelu 348.081	Threshold gasket-fixed part 348.081	Lpreč1-78	1	90-90
Brtva ispod maske u pragu 344.080	Threshold gask. under mask 344.080	ML1-Lpreč-31	1	90-90
Brtva ispod maske u pragu 344.080	Threshold gask. under mask 344.080	Lpreč.1-59	1	90-90
Brtva na spoju krila i fiksnog 344.113	Gasket on sash-fixed joint 344.113	MH-63.5	1	90-90
Brtva na spoju krila i fiksnog 344.113	Gasket on sash-fixed joint 344.113	MH-87	1	90-90
Brtva prema staklu /vanjska/ 328.002	Gasket to the glass /ext./ 328.002		2Lkr+2Hkr+2Lpreč1+2Lpreč+4MH	
Brtva prema staklu /unut./ 311.004	Gasket to the glass /inter./ 311.004		2Lkr+2Hkr+2Lpreč1+2Lpreč+4MH	
Brtva ispod maske F-1539 358.017	Gasket under mask F-1539 358.017		Lkr	
Brtva 347.012	Gasket 347.012		(ML/2)+3MH+2Hkr	
Izolacijski umetak po obodu stakla 340.013	Insulation insert along glass edge 340.013		2(Lkr-132)+2(Hkr-156)	
Izolacijski umetak 340.130	Insulation insert 340.130		1Hkr	
Izolacijski umetak 340.131	Insulation insert 340.131		1Hkr	
Izolacijski umetak 340.129	Insulation insert 340.129		ML1-Lpreč1-31	
Umetak na spoju dva krila-340.136	Insert on two sash joint-brushes 340.136		1	
Izolacijski umetak 340.132	Insulation insert 340.132		MH-80	

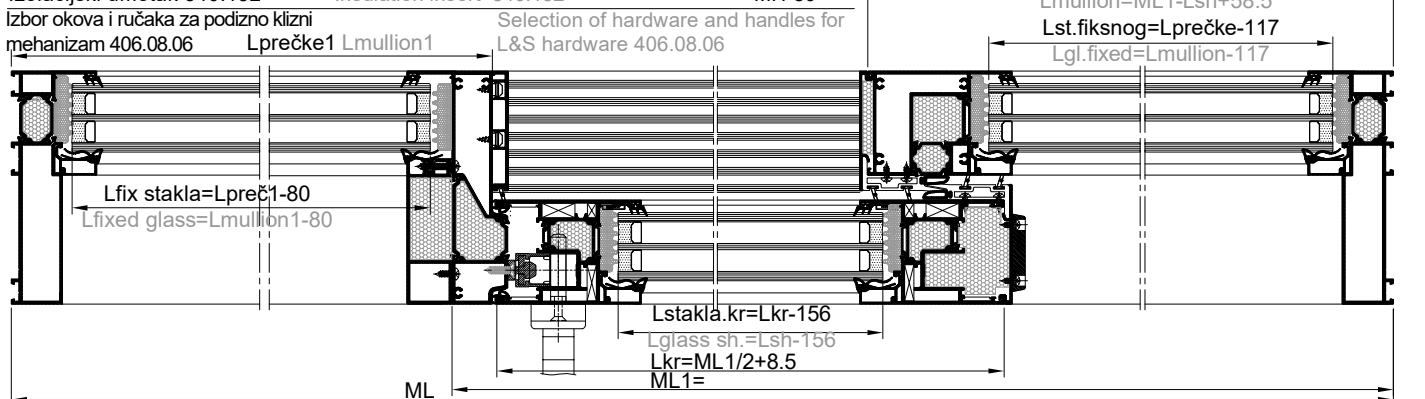

naziv name	mjera measure	kom. pcs.	pilanje cutting	
Okomica rama FT-1103F	Frame vertical FT-1103F	MH	2	90-90
Vodoravnica rama-donja FT-1102F	Frame horizontal-lower FT-1102F	ML-76	1	90-90
Vodoravnica rama-gornja FT-1101F	Frame horizontal-upper FT-1101F	ML-66	1	90-90
Krilo FT-1120F	Sash FT-1120F	(ML/2)+32.5*	2	45-45
Krilo FT-1120F	Sash FT-1120F	MH-87	1	45-45
Krilo FT-1121F	Sash FT-1121F	MH-87	1	45-45
Prečka FT-1130F	Mullion FT-1130F	MH-66	1	90-90
Prečka FT-1135F	Mullion FT-1135F	MH-54.5	1	90-90
Umetak rama FT-1132F	Frame insert FT-1132F	ML-(Lprečke1+43)	1	90-90
Maska F-1538	Mask F-1538	MH-63.5	1	90-90
Maska F-1538	Mask F-1538	MH-87	1	90-90
Maska praga F-1536	Threshold mask F-1536	ML1-Lpreč.-31	1	90-90
Maska praga F-1418	Threshold mask F-1418	ML-59	1	90-90
Vanjska st lajsna F-1419	Exterior glazing bead F-1419	Lpreč.-99.5	1	90-90
Vanjska st lajsna F-1419	Exterior glazing bead F-1419	Lpreč.1-110	1	90-90
Al vodilica F-1112 (elox)	Al guide F-1112 (elox)	ML1-64	1	90-90
Maska F-1537	Mask F-1537	ML1-Lpreč.-31	1	90-90
Maska F-1542	Mask F-1542	Lpreč.1-59	1	90-90
Maska F-1539	Mask F-1539	MH-80	1	90-90
Maska F-1434	Mask F-1434	MH-85	1	90-90
Staklo lajsna Z40-664	Glazing bead Z40-664	Lkr-94	2	90-90
Staklo lajsna Z40-664	Glazing bead Z40-664	Hkr-186	2	90-90
Staklo lajsna Z40-664	Glazing bead Z40-664	Lpreč-56	2	90-90
Staklo lajsna Z40-664	Glazing bead Z40-664	MH-107	3	90-90
Staklo lajsna Z40-664	Glazing bead Z40-664	Lpreč.1-59	2	90-90

Kutna spojnica 710.402	Corner bracket 710.402		2	
Kutna spojnica 710.401	Corner bracket 710.401		2	
Kutna spojnica 710.403	Corner bracket 710.403		2	
Kutna spojnica 710.404	Corner bracket 710.404		2	
Kutna spojnica 731.010	Corner bracket 731.010		8	
Kutna spojnica 730.017	Corner bracket 730.017		8	

Čep maske krila donji 373.051 (lijevi)	Cap mask on sash-lower 373.051 (left)		1	
Čep maske krila gornji 373.053	Cap mask on sash-upper 373.053		1	
Usmjerivač krila 373.078	Sash guide 373.078		4	
Umetak za odvod vode iz krila 360.009	Insert for sash drainage 360.009		2	
Odbojnik na krilu 345.010	Sash bumper 345.010		2	
Čep prečke 363.053 (lijevi)	Mullion cap 363.053 (left)		1	
Čep za donji spoj prečke 363.060	Cap for lower frame joint 363.060		1	
Čep prečke donji 363.053	Mullion cap-lower 363.053		1	
Čep prečke gornji 373.069	Mullion cap-upper 373.069		1	
Čep za donji spoj rama 373.070	Cap for lower frame joint 373.070		1	
Čep za gornji spoj rama 373.071	Cap for upper frame joint 373.071		1	
Čep za donji spoj rama 373.075	Cap for lower frame joint 373.075		1	
Čep za gornji spoj rama 373.076	Cap for upper frame joint 373.076		1	

Pvc profil 374.120	Pvc profile 374.120	MH-63.5	1	90-90
Pvc profil 374.120	Pvc profile 374.120	MH-87	1	90-90

Brтва krila 327.003	Sash gasket 327.003		2Lkr+2Hkr	
Brтва u gornj. horiz.pojasu krila 348.067	Upper horiz. sash zone gasket 348.067		Lkr	
Brтва u gornj. horiz.pojasu krila 348.109 <sup>x</sup>	Upper horiz. sash zone gasket 348.109 <sup>x</sup>		Lkr	
Brтва u donjem pojasu krila 348.079	Lower sash zone gasket 348.079		Lkr	
Brтва u pragu ispod krila 348.061	Under sash threshold gasket 348.061	ML1-74	1	90-90
Brтва u pragu u fiksnom dijelu 348.081	Threshold gasket-fixed part 348.081	Lpreč1-78	1	90-90
Brтва ispod maske u pragu 344.080	Threshold gasket under mask 344.080	ML1-Lpreč-31	1	90-90
Brтва ispod maske u pragu 344.080	Threshold gasket under mask 344.080	Lpreč.1-59	1	90-90
Brтва na spoju krila i fiksnog 344.113	Gasket on sash-fixed joint 344.113	MH-63.5	1	90-90
Brтва na spoju krila i fiksnog 344.113	Gasket on sash-fixed joint 344.113	MH-87	1	90-90
Brтва prema staklu /vanjska/ 328.002	Gasket to the glass /exterior/ 328.002		2Lkr+2Hkr+2Lpreč1+2Lpreč+4MH	
Brтва prema staklu /unutarja/ 311.004	Gasket to the glass /interior/ 311.004		2Lkr+2Hkr+2Lpreč1+2Lpreč+4MH	
Brтва ispod maske F-1539 358.017	Gasket under mask F-1539 358.017		Lkr	
Brтва 347.012	Gasket 347.012	(ML/2)+3MH+2Hkr		

Izolacijski umetak po obodu stakla 340.013	Insulation insert along glass edge 340.013		2(Lkr-86)+2(Hkr-156)	
--	--	--	----------------------	--

Izolacijski umetak 340.130	Insulation insert 340.130		1Hkr	
----------------------------	---------------------------	--	------	--

Izolacijski umetak 340.131	Insulation insert 340.131		1Hkr	
----------------------------	---------------------------	--	------	--

Izolacijski umetak 340.129	Insulation insert 340.129		ML1-Lpreč1-31	
----------------------------	---------------------------	--	---------------	--

Umetak na spoju dva krila- 340.137	Insert on two sash joint-brushes 340.137		1	
------------------------------------	--	--	---	--

Izolacijski umetak 340.132	Insulation insert 340.132		MH-80	
----------------------------	---------------------------	--	-------	--

Izbor okova i ručaka za podizno klizni mehanizam 406.08.06	Selection of hardware and handles for L&S hardware 406.08.06			
--	--	--	--	--

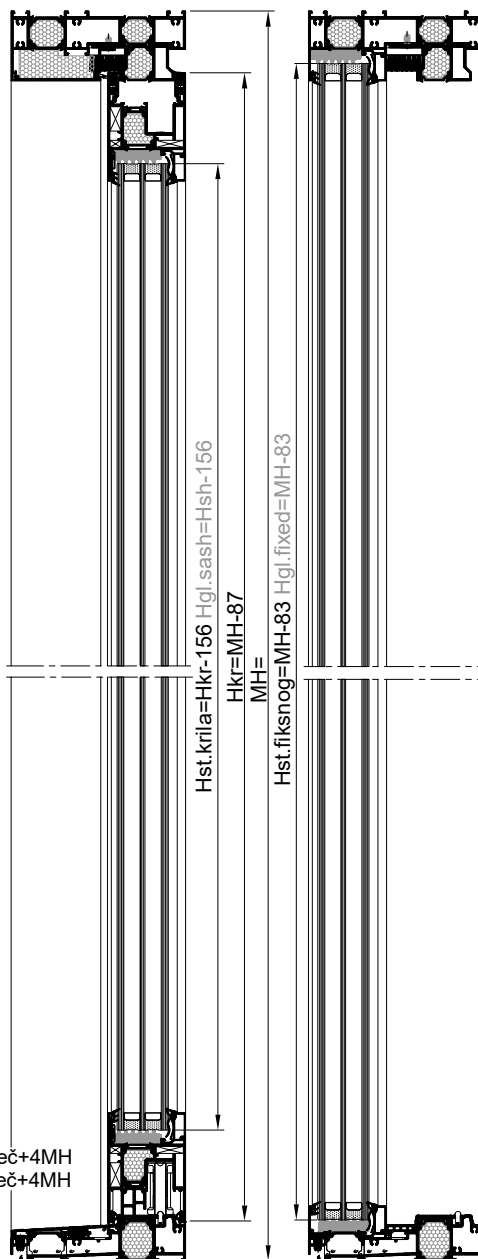
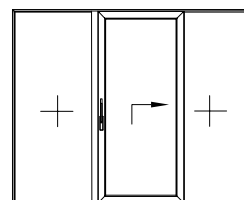

\* VIDJET STRANICU KATALOGA 406.11.117  
SEE PAGE 406.11.117

$$Lprečke=ML1-Lkr+10.5$$

$$Lmullion=ML1-Lsh+10.5$$

$$Lst.fiksnog=Lprečke-69$$

$$Lgl.fixed=Lmullion-69$$

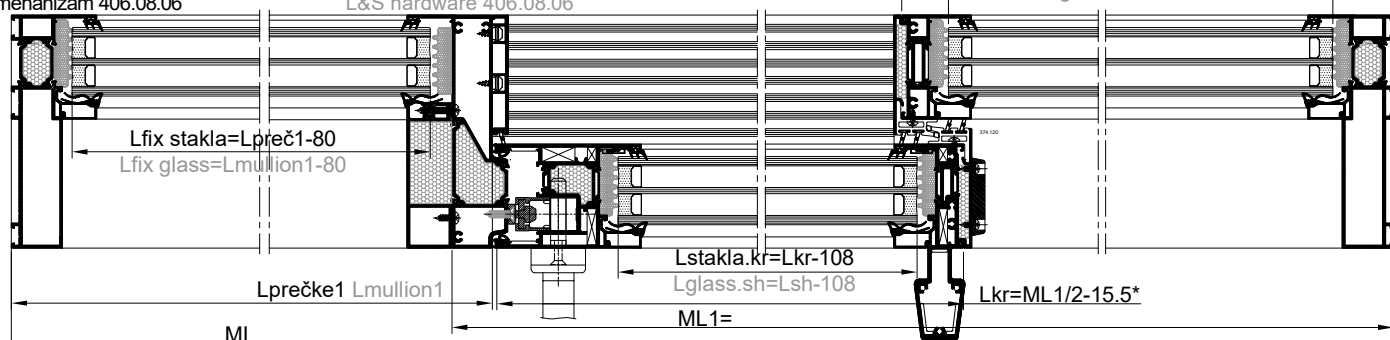

# Ravno pilanje rama

## Straight frame cutting

naziv name	mjera measure	kom. pcs.	pilanje cutting	
Okomica rama FT-1100F	Frame vertical FT-1100F	MH	1	90-90
Okomica rama FT-1103F	Frame vertical FT-1103F	MH	1	90-90
Vodoravnica rama-donja FT-1102F	Frame horizontal-lower FT-1102F	ML-85	1	90-90
Vodoravnica rama-gornja FT-1101F	Frame horizontal-upper FT-1101F	ML-102	1	90-90
Krilo FT-1120F	Sash FT-1120F	ML/2+6	2	45-45
Krilo FT-1120F	Sash FT-1120F	MH-87	2	45-45
Prečka FT-1131F	Mullion FT-1131F	MH-85	1	90-90
Umetak rama FT-1132F	Frame insert FT-1132F	ML-79	1	90-90
Maska F-1538	Mask F-1538	MH-63.5	1	90-90
Maska F-1538	Mask F-1538	MH-87	1	90-90
Maska praga F-1536	Threshold mask F-1536	ML-Lpreč.-37.5	1	90-90
Maska praga F-1418	Threshold mask F-1418	ML-59	1	90-90
Vanjska st lajsna F-1419	Exterior glazing bead F-1419	Lpreč.-147.5	1	90-90
Al vodilica F-1112 (elox)	Al guide F-1112 (elox)	ML-85	1	90-90
Maska F-1537	Mask F-1537	ML-Lpreč.-37	1	90-90
Maska F-1434	Mask F-1434	MH-85	1	90-90
Staklo lajsna Z40-664	Glazing bead Z40-664	Lkr-142	2	90-90
Staklo lajsna Z40-664	Glazing bead Z40-664	Hkr-186	2	90-90
Staklo lajsna Z40-664	Glazing bead Z40-664	Lpreč-104	2	90-90
Staklo lajsna Z40-664	Glazing bead Z40-664	MH-107	2	90-90
Kutna spojnica 710.401	Corner bracket 710.401		4	
Kutna spojnica 710.403	Corner bracket 710.403		4	
Kutna spojnica 731.010	Corner bracket 731.010		4	
Kutna spojnica 730.017	Corner bracket 730.017		8	
Čep prečke donji 373.067	Mullion cap-lower 373.067		1	
Čep prečke gornji 373.068	Mullion cap-upper 373.068		1	
Set umetaka zaspoj rama 373.086	Set of inserts for frame connection 373.086		1	
Čep maske krila donji 373.051(lj.)	Cap mask on sash-lower 373.051(lf.)		1	
Čep maske krila gornji 373.053	Cap mask on sash-upper 373.053		1	
Usmjerivač krila 373.078	Sash guide 373.078		4	
Umetak za odvod vode iz krila 360.009	Insert for sash drainage 360.009		2	
Odbojnik na krilu 345.010	Sash bumper 345.010		2	
Pvc profil 374.083	Pvc profile 374.083	MH-63.5	1	90-90
Pvc profil 374.083	Pvc profile 374.083	MH-87	1	90-90
Brtva krila 327.003	Sash gasket 327.003		2Lkr+2Hkr	
Brtva u gornjem horiz. pojasu krila 348.067	Upper horiz. sash zone gasket 348.067		Lkr	
Brtva u gornjem horiz. pojasu krila 348.109 <sup>X</sup>	Upper horiz. sash zone gasket 348.109 <sup>X</sup>		Lkr	
Brtva u donjem pojasu krila 348.079	Lower sash zone gasket 348.079		Lkr	
Brtva u pragu ispod krila 348.061	Under sash threshold gasket 348.061	ML-79	1	90-90
Brtva u pragu u fiksnom dijelu 348.081	Threshold gasket-fixed part 348.081	Lpreč-78	1	90-90
Brtva ispod maske u pragu 344.080	Threshold gask. under mask 344.080	ML-Lpreč-48	1	90-90
Brtva na spoju krila i fiksnog 344.113	Gasket on sash-fixed joint 344.113	MH-63.5	1	90-90
Brtva na spoju krila i fiksnog 344.113	Gasket on sash-fixed joint 344.113	MH-87	1	90-90
Brtva prema staklu /vanjska/ 328.002	Gasket to the glass /exterior/ 328.002		2Lkr+2Hkr+2Lfix+2MH	
Brtva prema staklu /unutarnja/ 311.004	Gasket to the glass /interior/ 311.004		2Lkr+2Hkr+2Lfix+2MH	
Brtva 347.012	Gasket 347.012		(ML/2)+3MH+2Hkr	
Izolacijski umetak po obodu stakla 340.013	Insulation insert along glass edge 340.013		2(Lkr-132)+2(Hkr-156)	
Izolacijski umetak 340.130	Insulation insert 340.130		Hkr	
Izolacijski umetak 340.131	Insulation insert 340.131		Hkr	
Izolacijski umetak 340.129	Insulation insert F-1537 340.129		ML-Lpreč-37	
Umetak na spoju dva krila 340.136	Insert on two sash joint-brushes 340.136		1	
Izbor okova i ručaka za podizno klizni mehanizam 406.08.06	Selection of hardware and handles for L&S hardware 406.08.06			
X-brtva-opcija (za pozicije izložene udarima padalina)	X-gasket-options (for positions exposed to rainfall)			

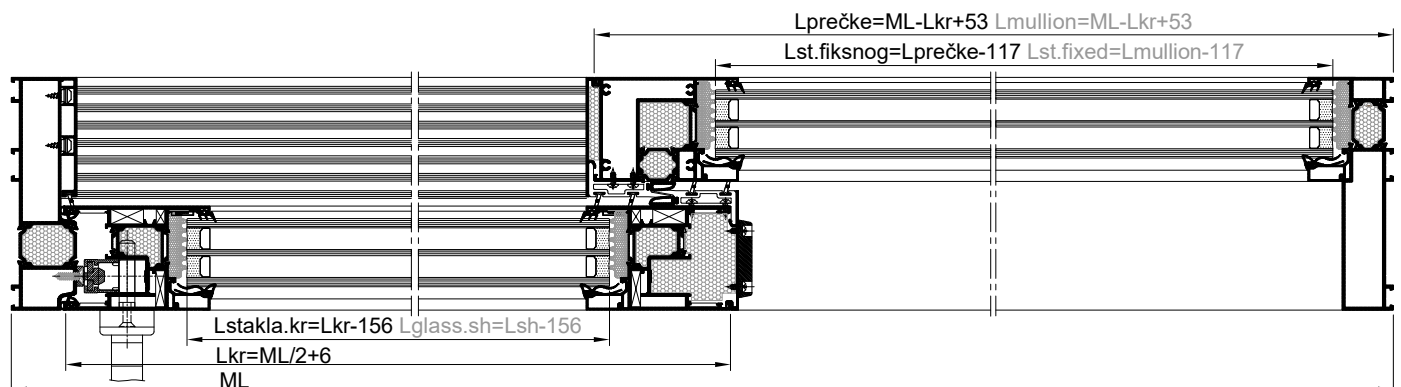
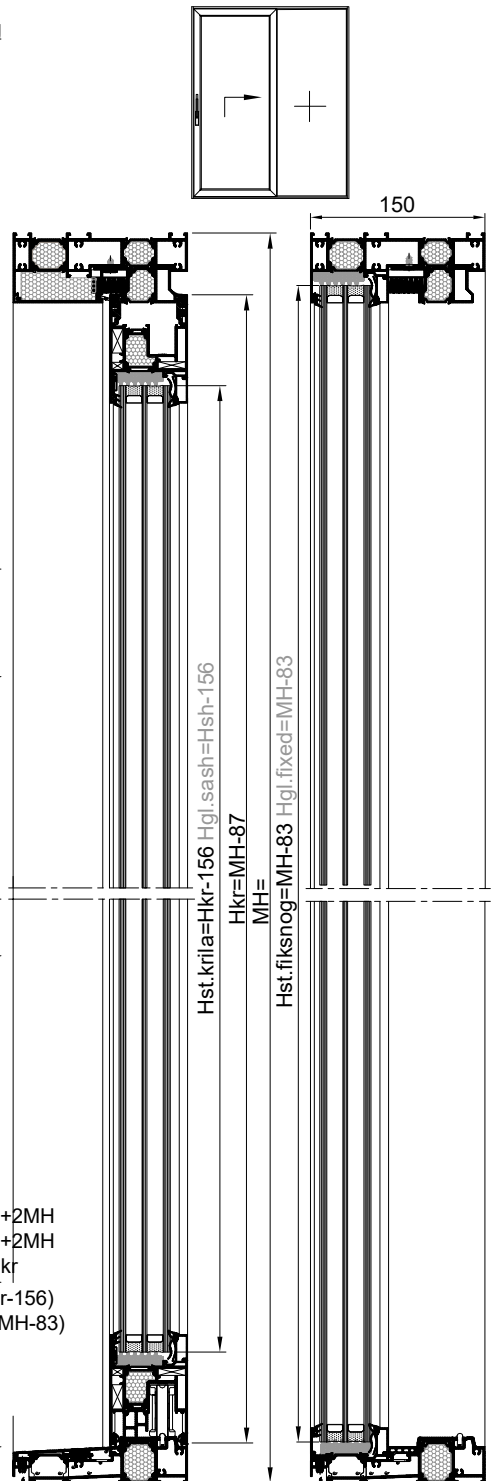

naziv name	mjera measure	kom. pcs.	pilanje cutting
FOkomica rama FT-1100	Frame vertical FT-1100	MH	1 90-90
Okomica rama FT-1103F	Frame vertical FT-1103	MH	1 90-90
Vodoravnica rama-donja FT-1102F	Frame horizontal-lower FT-1102F	ML-85	1 90-90
Vodoravnica rama-gornja FT-1101F	Frame horizontal-upper FT-1101F	ML-102	1 90-90
Krilo FT-1120F	Sash FT-1120F	ML/2+29.5*	2 45-45
Krilo FT-1120F	Sash FT-1120F	MH-87	1 45-45
Krilo FT-1121F	Sash FT-1121F	MH-183	1 45-45
Prečka FT-1130F	Mullion FT-1130F	MH-66	1 90-90
Umetak rama FT-1132F	Frame insert FT-1132F	ML-79	1 90-90
Maska F-1538	Mask F-1538	MH-63.5	1 90-90
Maska F-1538	Mask F-1538	MH-87	1 90-90
Maska praga F-1536	Threshold mask F-1536	ML-Lpreč.-37.5	1 90-90
Maska praga F-1418	Threshold mask F-1418	ML-59	1 90-90
Vanjska st lajsna F-1419	Exterior glazing bead F-1419	Lpreč-99.5	1 90-90
Al vodilica F-1112 (elox)	Al guide F-1112 (elox)	ML-85	1 90-90
Maska F-1537	Mask F-1537	ML-Lpreč.-37	1 90-90
Maska F-1434	Mask F-1434	MH-85	1 90-90
Staklo lajsna Z40-664	Glazing bead Z40-664	Lkr-94	2 90-90
Staklo lajsna Z40-664	Glazing bead Z40-664	Hkr-186	2 90-90
Staklo lajsna Z40-664	Glazing bead Z40-664	Lprečke-56	2 90-90
Staklo lajsna Z40-664	Glazing bead Z40-664	MH-107	2 90-90
Kutna spojnica 710.402	Corner bracket 710.402		2
Kutna spojnica 710.401	Corner bracket 710.401		2
Kutna spojnica 710.403	Corner bracket 710.403		2
Kutna spojnica 710.404	Corner bracket 710.404		2
Kutna spojnica 731.010	Corner bracket 731.010		4
Kutna spojnica 730.017	Corner bracket 730.017		4
Set umetaka za spoj rama 373.086	Set of inserts for frame connection 373.086		1
Čep maske krila donji 373.051	Cap mask on sash-lower 373.051		1
Čep maske krila gornji 373.053	Cap mask on sash-upper 373.053		1
Usmjerivač krila 373.078	Sash guide 373.078		4
Umetak za odvod vode iz krila 360.009	Insert for sash drainage 360.009		2
Odbojnik na krilu 345.010	Sash bumper 345.010		2
Čep profila malog krila FT-1121 363.052	Cap of small sash profile FT-1121 363.052		1 par
Čep prečke 363.053	Mullion cap 363.053		1
Čep prečke 373.069	Mullion cap 373.069		1
Pvc profil 374.120	Pvc profile 374.120	MH-63.5	1 90-90
Pvc profil 374.120	Pvc profile 374.120	MH-87	1 90-90
Brtva krila 327.003	Sash gasket 327.003		2Lkr+2Hkr
Brtva u gornjem horiz. pojasu krila 348.067	Upper horiz. sash zone gasket 348.067		Lkr
Brtva u gornjem horiz. pojasu krila 348.109 <sup>X</sup>	Upper horiz. sash zone gasket 348.109 <sup>X</sup>		Lkr
Brtva u donjem pojasu krila 348.079	Lower sash zone gasket 348.079		Lkr
Brtva u pragu ispod krila 348.061	Under sash threshold gask. 348.061	ML-79	1 90-90
Brtva u pragu u fiks. dijelu 348.081	Threshold gask.-fixed part 348.081	Lpreč-56	1 90-90
Brtva ispod maske u pragu 344.080	Threshold ga. under mask 344.080	ML-Lpreč-48	1 90-90
Brtva na spoju krila i fiksnog 344.113	Gasket on sash-fixed joint 344.113	MH-63.5	1 90-90
Brtva na spoju krila i fiksnog 344.113	Gasket on sash-fixed joint 344.113	MH-87	1 90-90
Brtva prema staklu /vanj./ 328.002	Gasket to the glass/exterior/ 328.002		2Lkr+2Hkr+2Lfix+2MH
Brtva prema staklu /unut./ 311.004	Gasket to the glass/interior/ 311.004		2Lkr+2Hkr+2Lfix+2MH
Brtva 347.012	Gasket 347.012		(ML/2)+3MH+2Hkr
Izolacijski umetak po obodu stakla 340.013	Insulation insert along glass edge 340.013		2(Lkr-86)+2(Hkr-156) +2(Lpreč-46)+2(MH-83)
Izolacijski umetak 340.131	Insulation insert 340.131		2Hkr
Izolacijski F-1537 340.129	Insulation insert F-1537 340.129		ML-Lpreč-37
Umetak na spoju dva krila- 340.137	Insert on two sash joint-brushes 340.137		1
Izbor okova i ručaka za podizno klizni mehanizam 406.08.06	Selection of hardware and handles for L&S hardware 406.08.06		
X-brtva-opcija (za pozicije izložene udarima padalina)	X-gasket-options (for positions exposed to rainfall)		

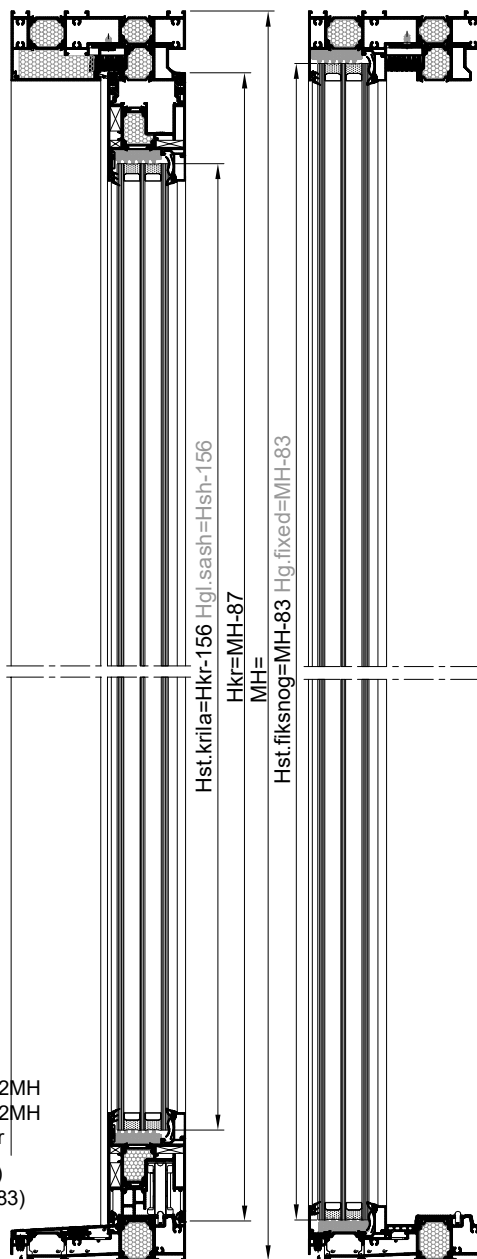
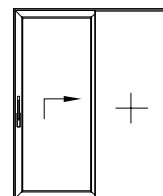

\*VIDJET STRANICU KATALOGA 406.11.111  
SEE PAGE 406.11.111

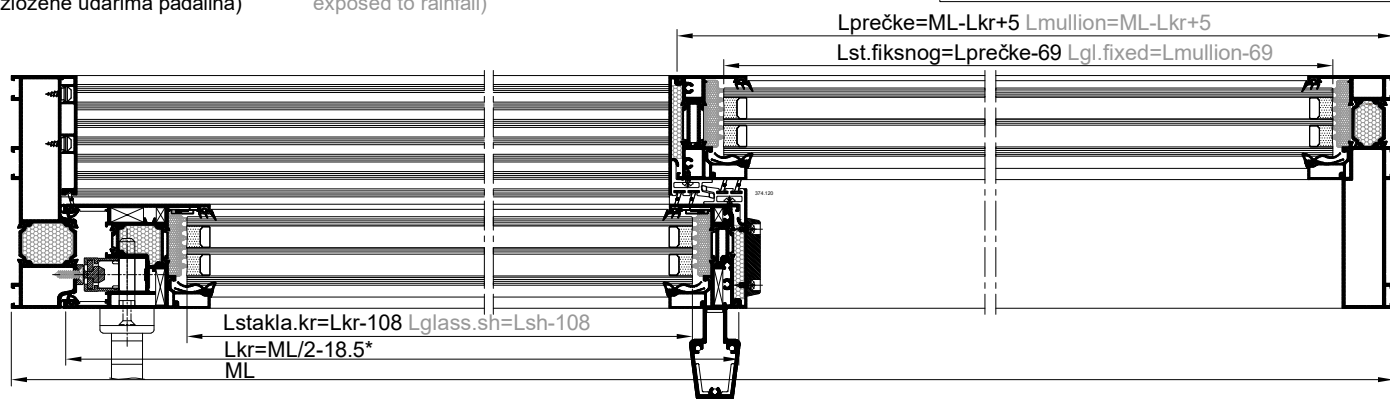

naziv name	mjera measure	kom. pcs.	pilanje cutting
Okomica rama FT-1100F	Frame vertical FT-1100F	MH	2
Vodoravnica rama-donja FT-1102F	Frame horizontal-lower FT-1102F	ML-94	1
Vodoravnica rama-gornja FT-1101F	Frame horizontal-upper FT-1101F	ML-94	1
Krilo FT-1120F	Sash FT-1120F	ML/4+22	4
Krilo FT-1120F	Sash FT-1120F	MH-87	4
Prečka FT-1131F	Mullion FT-1131F	MH-85	2
Umetak rama FT-1132F	Frame insert FT-1132F	ML-94	1
Maska F-1538	Mask F-1538	MH-63.5	2
Maska F-1538	Mask F-1538	MH-87	2
Maska praga F-1536	Threshold mask F-1536	Lpreč.-37.5	2
Maska praga F-1418	Threshold mask F-1418	ML-64	1
Vanjska st lajsna F-1419	Exterior glazing bead F-1419	ML-2Lpreč.-186	1
Al vodilica F-1112 (elox)	Al guide F-1112 (elox)	ML-94	1
Maska F-1537	Mask F-1537	Lpreč.-37	2
Maska F-1434	Mask F-1434	MH-85	2
Staklo lajsna Z40-664	Glazing bead Z40-664	Lkr-142	4
Staklo lajsna Z40-664	Glazing bead Z40-664	Hkr-186	4
Staklo lajsna Z40-664	Glazing bead Z40-664	ML-2Lpreč.-142	2
Staklo lajsna Z40-664	Glazing bead Z40-664	MH-107	2
Kutna spojnica 710.401	Corner bracket 710.401		8
Kutna spojnica 710.403	Corner bracket 710.403		8
Kutna spojnica 731.010	Corner bracket 731.010		8
Kutna spojnica 730.017	Corner bracket 730.017		16
Čep maske krila donji 373.051 (lijevi)	Cap mask on sash-lower 373.051 (lft.)		1
Čep maske krila donji 373.052 (desni)	Cap mask on sash-upper 373.052 (rgh.)		1
Čep maske krila gornji 373.053	Sash mask cap - upper 373.053		2
Usmjerivač krila 373.078	Sash guide 373.078		8
Set umetaka za spoj rama 373.088	Set of inserts for frame connection 373.088		1
Čep prečke donji 373.067	Mullion cap-lower 373.067		1
Čep prečke gornji 373.068	Mullion cap-upper 373.068		1
Čep prečke donji 373.072	Mullion cap-lower 373.072		1
Čep prečke gornji 373.073	Mullion cap-upper 373.073		1
Umetak za odvod vode iz krila 360.009	Insert for sash drainage 360.009		4
Odbojnik na krilu 345.010	Sash bumper 345.010		4
Pvc profil 374.083	Pvc profile 374.083	MH-63.5	2
Pvc profil 374.083	Pvc profile 374.083	MH-87	2
Brtva krila 327.003	Sash gasket 327.003		4Lkr+4Hkr
Brtva u gor.horiz. pojasu krila 348.067	Upper horiz. sash zone gasket 348.067		2 Lkr
Brtva u gor.horiz. pojasu krila 348.109 <sup>x</sup>	Upper horiz. sash zone gasket 348.109 <sup>x</sup>		2 Lkr
Brtva u donjem pojasu krila 348.079	Lower sash zone gasket 348.079		2Lkr
Brtva u pragu ispod krila 348.061	Under sash threshold gas. 348.061	ML-94	1
Brtva u pragu u fiks. dijelu 348.081	Threshold gask.-fixed part 348.081	ML-2Lpreč-100	1
Brtva ispod maske u pragu 344.080	Threshold gask. under mask 344.080	Lpreč-48	2
Brtva na spoju krila i fik. 344.113	Gasket on sash-fixed joint 344.113	MH-63.5	2
Brtva na spoju krila i fik. 344.113	Gasket on sash-fixed joint 344.113	MH-87	2
Brtva prema staklu/vanj./ 328.002	Gasket to the glass /exterior/ 328.002		4Lkr+4Hkr+2Lfix+2MH
Brtva prema staklu /unut./ 311.004	Gasket to the glass /interior/ 311.004		4Lkr+4Hkr+2Lfix+2MH
Četkasta brtva 347.012	Brush gasket 347.012		(ML/2)+6MH+4Hkr
Izolacijski umetak po obodu stakla 340.013	Insulation insert along glass edge 340.013		4(Lkr-132)+4(Hkr-156) + 2(ML-2Lpreč-132)+2(MH-83)
Izolacijski umetak 340.130	Insulation insert 340.130		2Hkr
Izolacijski umetak 340.131	Insulation insert 340.131		2Hkr
Izolacijski umetak 340.129	Insulation insert 340.129		2(Lpreč-37)
Umetak na spoju dva krila-340.136	Insert on two sash joint-brushes 340.136		2
Izbor okova i ručaka za podizno klizni mehanizam 406.08.06	Selection of hardware and handles for L&S hardware 406.08.06		
X-brtva-opcija (za pozicije izložene udarima padalina)	X-gasket-options (for positions exposed to rainfall)		

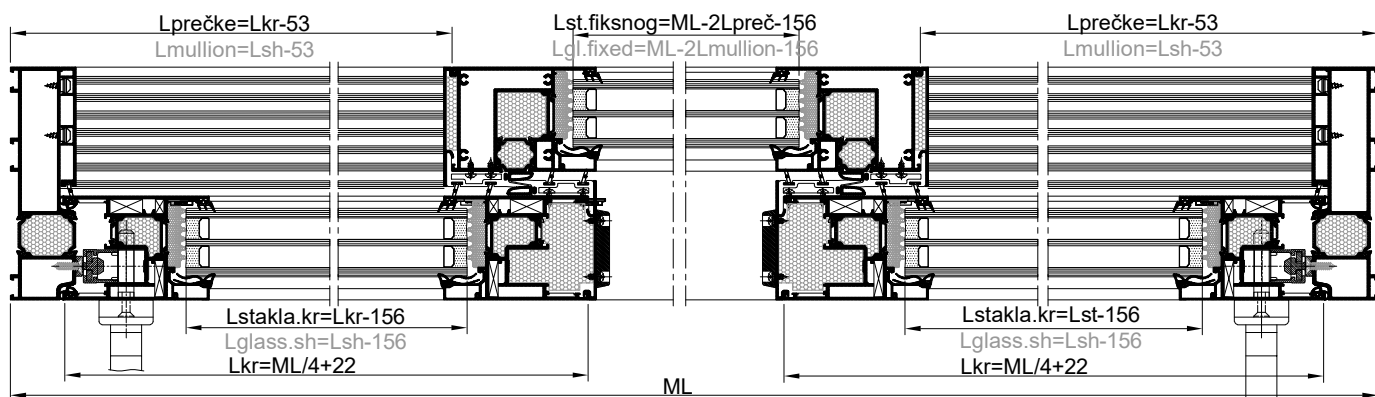
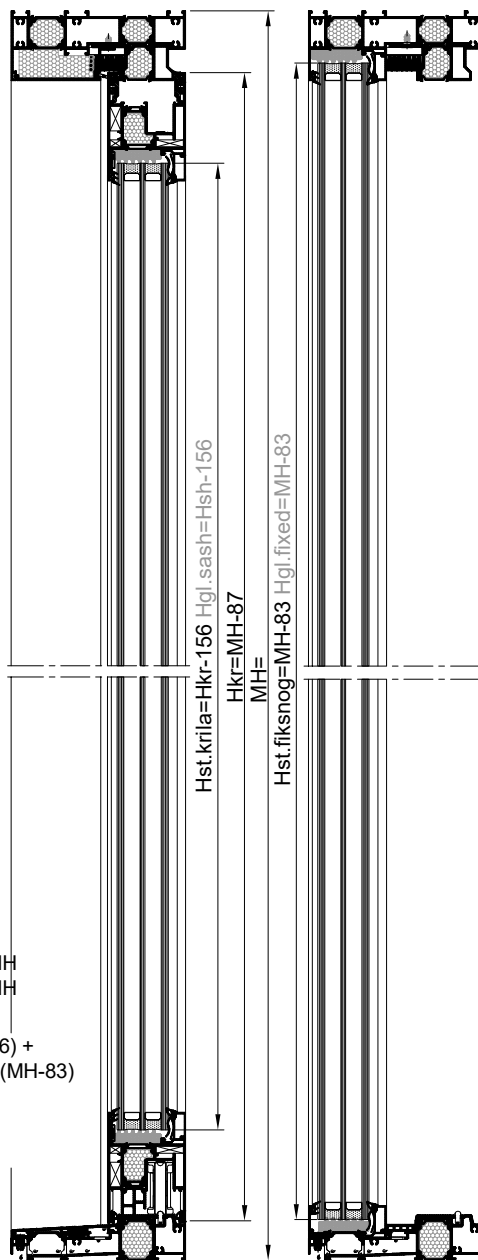
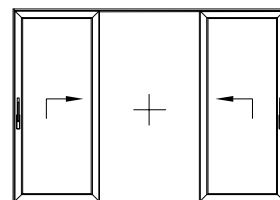

naziv name	mjera measure	kom. pcs.	pilanje cutting	
Okomica rama FT-1100F	Frame vertical FT-1100	MH	2	90-90
Vodoravnica rama-donja FT-1102F	Frame horizontal-lower FT-1102F	ML-94	1	90-90
Vodoravnica rama-gornja FT-1101F	Frame horizontal-upper FT-1101F	ML-94	1	90-90
Krilo FT-1120F	Sash FT-1120F	(ML/4)+46 *	4	45-45
Krilo FT-1120F	Sash FT-1120F	MH-87	2	45-45
Krilo FT-1121F	Sash FT-1121F	MH-183	2	45-45
Prečka FT-1130F	Mullion FT-1131F	MH-66	2	90-90
Umetak rama FT-1132F	Frame insert FT-1132F	ML-94	1	90-90
Maska F-1538	Mask F-1538	MH-63.5	2	90-90
Maska F-1538	Mask F-1538	MH-87	2	90-90
Maska praga F-1536	Threshold mask F-1536	Lpreč.-37.5	2	90-90
Maska praga F-1418	Threshold mask F-1418	ML-64	1	90-90
Vanjska st lajsna F-1419	Exterior glazing bead F-1419	ML-2Lpreč.-90	1	90-90
Al vodilica F-1112 (elox)	Al guide F-1112 (elox)	ML-94	1	90-90
Maska F-1537	Mask F-1537	Lpreč.-37	2	90-90
Maska F-1434	Mask F-1434	MH-85	2	90-90
Staklo lajsna Z40-664	Glazing bead Z40-664	Lkr-94	4	90-90
Staklo lajsna Z40-664	Glazing bead Z40-664	Hkr-186	4	90-90
Staklo lajsna Z40-664	Glazing bead Z40-664	ML-2Lpreč-46	2	90-90
Staklo lajsna Z40-664	Glazing bead Z40-664	MH-107	2	90-90
Kutna spojnica 710.402	Corner bracket 710.402		4	
Kutna spojnica 710.401	Corner bracket 710.401		4	
Kutna spojnica 710.403	Corner bracket 710.403		4	
Kutna spojnica 710.404	Corner bracket 710.403		4	
Kutna spojnica 731.010	Corner bracket 731.010		8	
Kutna spojnica 730.017	Corner bracket 730.017		8	
Čep maske krila donji 373.051 (lijevi)	Cap mask on sash-lower 373.051 (ft.)		1	
Čep maske krila donji 373.052 (desni)	Cap mask on sash-upper 373.052 (rgh.)		1	
Čep maske krila gornji 373.053	Sash mask cap - upper 373.053		2	
Usmjerivač krila 373.078	Sash guide 373.078		8	
Set umetaka za spoj rama 373.088	Set of inserts for frame connection 373.088		1	
Umetak za odvod vode iz krila 360.009	Insert for sash drainage 360.009		4	
Odbojnik na krilu 345.010	Sash bumper 345.010		4	
Čep profila krila FT-1121 363.052	Cap for sash profile FT-1121 363.052		2 par	
Čep prečke 363.053 (lijevi)	Mullion cap 363.053 (ft.)		1	
Čep prečke 363.054 (desni)	Mullion cap 363.054 (rgh.)		1	
Čep prečke gornji 373.069	Mullion cap upper 373.069		1	
Čep prečke gornji 373.074	Mullion cap upper 373.074		1	
Pvc profil 374.120	Pvc profile 374.120	MH-63.5	2	90-90
Pvc profil 374.120	Pvc profile 374.120	MH-87	2	90-90
Brtva krila 327.003	Sash gasket 327.003		4Lkr+4Hkr	
Brtva u gornj. horiz. pojasu krila 348.067	Upper horiz. sash zone gasket 348.067		2 Lkr	
Brtva u gornj. horiz. pojasu krila 348.109 <sup>X</sup>	Upper horiz. sash zone gasket 348.109 <sup>X</sup>		2 Lkr	
Brtva u donjem pojasu krila 348.079	Lower sash zone gasket 348.079		2Lkr	
Brtva u pragu ispod krila 348.061	Under sash threshold gas. 348.061	ML-94	1	90-90
Brtva u pragu u fiks. dijelu 348.081	Threshold gask.-fixed part 348.081	ML-2Lpreč-46	1	90-90
Brtva ispod maske u pragu 344.080	Threshold gask. under mask 344.080	Lpreč-48	2	90-90
Brtva na spoju krila i fiksnog 344.113	Gasket on sash-fixed joint 344.113	MH-63.5	2	90-90
Brtva na spoju krila i fiksnog 344.113	Gasket on sash-fixed joint 344.113	MH-87	2	90-90
Brtva prema staklu /vanjska/ 328.002	Gasket to the glass /exterior/ 328.002		4Lkr+4Hkr+2Lfix+2MH	
Brtva prema staklu /unut./ 311.004	Gasket to the glass /interior/ 311.004		4Lkr+4Hkr+2Lfix+2MH	
Brtva 347.012	Gasket 347.012		(ML/2)+6MH+4Hkr	
Izolacijski umetak 340.013	Insulation insert 340.013		4(Lkr-86)+4(Hkr-156) +2(ML-2Lpreč-46)+2(MH-83)	
Izolacijski umetak 340.131	Insulation insert 340.131		4Hkr	
Izolacijski umetak 340.129	Insulation insert 340.129		2(Lpreč-37)	
Umetak na spoju dva krila- 340.137	Insert on two sash joint-brushes 340.137		2	
Izbor okova i ručaka za podizno klizni mehanizam 406.08.06	Selection of hardware and handles for L&S hardware 406.08.06			
X-brtva-opcija (za pozicije izložene udarima padalina)	X-gasket-options (for positions exposed to rainfall)			

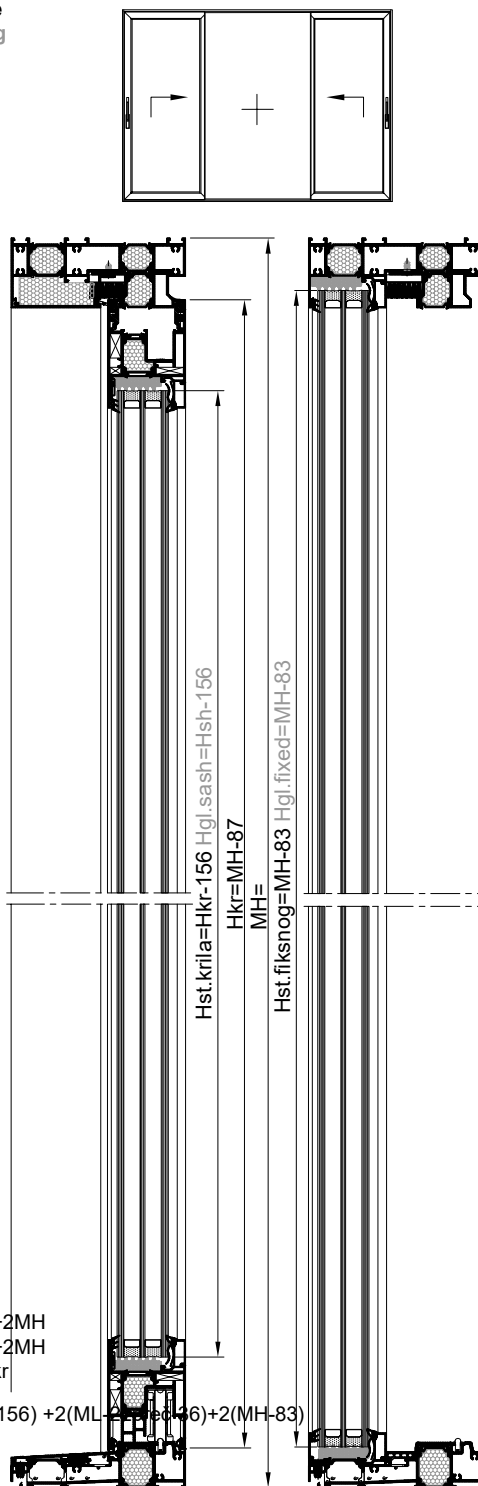

\* VIDJET STRANICU KATALOGA 406.11.117  
SEE PAGE 406.11.117

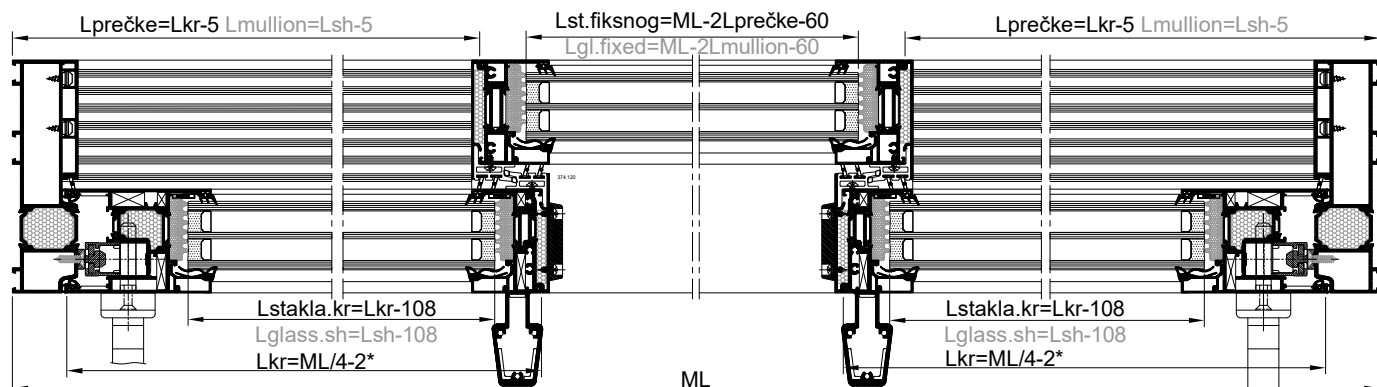

naziv name	mjera measure	kom. pcs.	pilanje cutting
Okomica rama FT-1103F	Frame vertical FT-1103F	MH	2 90-90
Vodoravnica rama-donja FT-1102F	Frame horizontal-lower FT-1102F	ML-76	1 90-90
Vodoravnica rama-gornja FT-1101F	Frame horizontal-upper FT-1101F	ML-110	1 90-90
Krilo FT-1120F	Sash FT-1120F	ML/4+22	4 45-45
Krilo FT-1120F	Sash FT-1120F	MH-87	4 45-45
Prečka FT-1131F	Mullion FT-1131F	MH-85	2 90-90
Umetak rama FT-1132F	Frame insert FT-1132F	ML-64	1 90-90
Umetak krila FT-1030F	Frame insert FT-1030F	MH-87	1 90-90
Maska F-1538	Mask F-1538	MH-63.5	2 90-90
Maska F-1538	Mask F-1538	MH-87	2 90-90
Maska praga F-1536	Treshold mask F-1536	ML-2Lpreč-10	1 90-90
Maska praga F-1418	Treshold mask F-1418	ML-108	1 90-90
Vanjska st lajsna F-1419	Exterior glazing bead F-1419	Lpreč-148	2 90-90
Al vodilica F-1112 (elox)	Al guide F-1112 (elox)	ML-76	1 90-90
Maska F-1537	Mask F-1537	ML-2Lpreč-10	1 90-90
Staklo lajsna Z40-664	Glazing bead Z40-664	Lkr-142	4 90-90
Staklo lajsna Z40-664	Glazing bead Z40-664	Hkr-186	4 90-90
Staklo lajsna Z40-664	Glazing bead Z40-664	Lpreč-104	4 90-90
Staklo lajsna Z40-664	Glazing bead Z40-664	MH-107	4 90-90
Kutna spojnica 710.401	Corner bracket 710.401		8
Kutna spojnica 710.403	Corner bracket 710.403		8
Kutna spojnica 731.010	Corner bracket 731.010		8
Kutna spojnica 730.017	Corner bracket 730.017		16
Čep maske krila donji 373.051 (lijevi)	Cap mask on sash-lower 373.051 (lft.)		1
Čep maske krila donji 373.052 (desni)	Cap mask on sash-upper 373.052 (rg.)		1
Čep maske krila gornji 373.053	Sash mask cap - upper 373.053		2
Usmjerivač krila 373.078	Sash guide 373.078		8
Čep za profil FT-1030 363.030	Cap for profile FT-1030 363.030		1 par
Čep prečke donji 373.067	Mullion cap-lower 373.067		1
Čep prečke gornji 373.068	Mullion cap-upper 373.068		1
Set umetaka za spoj rama 373.089	Set of inserts for frame connection 373.089		1
Čep prečke donji 373.072	Mullion cap-lower 373.072		1
Čep prečke gornji 373.073	Mullion cap-upper 373.073		1
Umetak za odvod vode iz krila 360.009	Insert for sash drainage 360.009		4
Odbojnik na krilu 345.010	Sash bumper 345.010		4
Pvc profil 374.083	Pvc profile 374.083	MH-63.5	2 90-90
Pvc profil 374.083	Pvc profile 374.083	MH-87	2 90-90
Brtva krila 327.003	Sash gasket 327.003		2Lkr+2Hkr
Brtva u gornj. horiz.pojasu krila 348.067	Upper horizontal sash zone gasket 348.067		2 Lkr
Brtva u gornj. horiz.pojasu krila 348.109 <sup>X</sup>	Upper horizontal sash zone gasket 348.109 <sup>X</sup>		2 Lkr
Brtva u donjem pojasu krila 348.079	Lower sash zone gasket 348.079		2Lkr
Brtva u pragu ispod krila 348.061	Under sash treshold gas. 348.061	ML-66	1 90-90
Brtva u pragu u fiksnom dijelu 348.081	Treshold gask.-fixed part 348.081	Lpreč-88	2 90-90
Brtva ispod maske u pragu 344.080	Treshold gask. under mask 344.080	ML-2Lpreč.-10	1 90-90
Brtva na spoju krila i fiksnog 344.113	Gasket on sash-fixed joint 344.113	MH-63.5	2 90-90
Brtva na spoju krila i fiksnog 344.113	Gasket on sash-fixed joint 344.113	MH-87	2 90-90
Brtva prema staklu /vanjska/ 328.002	Gasket to the glass /exterior/ 328.002		4Lkr+4Hkr+4Lfix+4MH
Brtva prema staklu /unutarnja/ 311.004	Gasket to the glass /interior/ 311.004		4Lkr+4Hkr+4Lfix+4MH
Brtva 347.012	Gasket 347.012		(ML/2)+4MH+4Hkr
Izolacijski umetak po obodu stakla 340.013	Insulation insert along glass edge 340.013		4(Lkr-132)+4(Hkr-156) +4(Lpreč-94)+4(MH-83)
Izolacijski umetak 340.130	Insulation insert 340.130		2Hkr
Izolacijski umetak 340.131	Insulation insert 340.131		2Hkr
Izolacijski umetak 340.129	Insulation insert 340.129		ML-2Lpreč-10
Umetak na spoju dva krila- 340.136	Insert on two sash joint-brushes 340.136		2

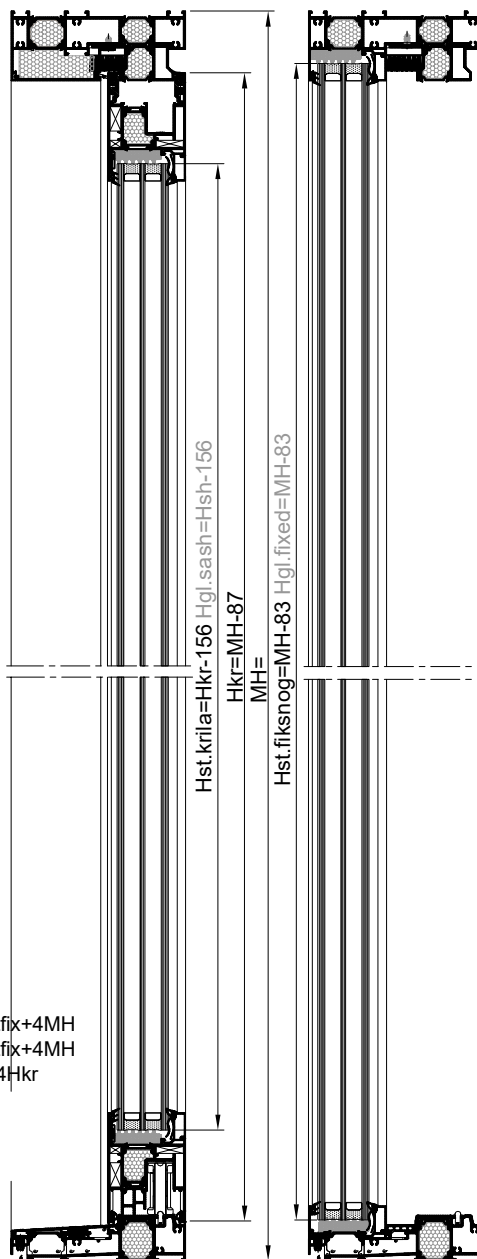
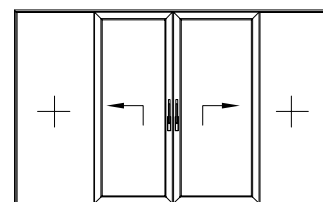

Izbor okova i ručaka za podizno klizni mehanizam 406.08.06 Selection of hardware and handles for L&S hardware 406.08.06

X-brtva-opcija (za pozicije izložene udarima padalina) X-gasket-options (for positions exposed to rainfall)

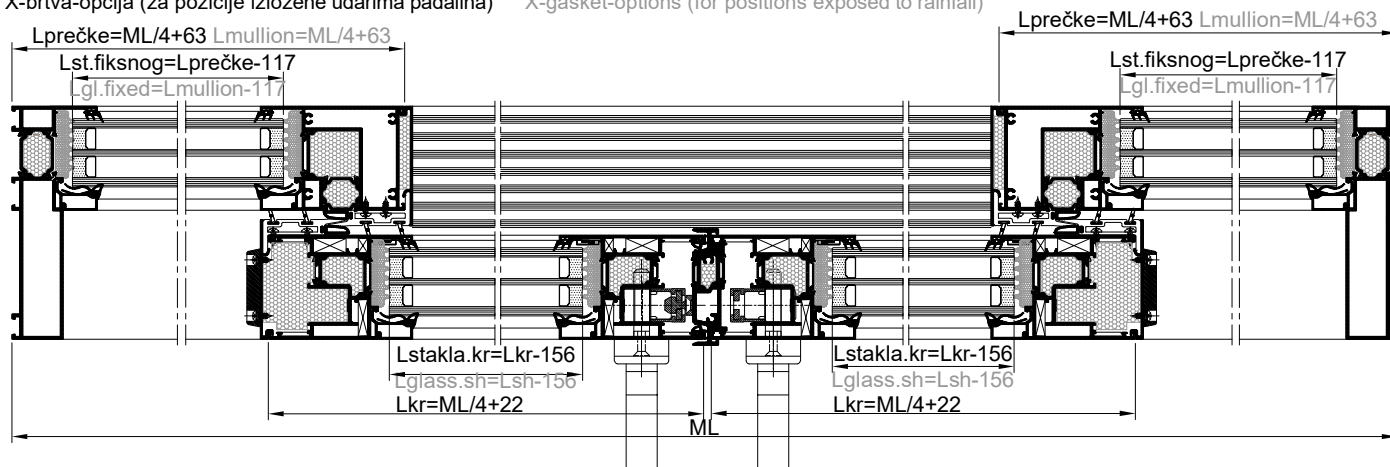

naziv name	mjera measure	kom. pcs.	pilanje cutting
Okomica rama FT-1103F	Frame vertical FT-1103F	MH	2 90-90
Vodoravnica rama-donja FT-1102F	Frame horizontal-lower FT-1102F	ML-76	1 90-90
Vodoravnica rama-gornja FT-1101F	Frame horizontal-upper FT-1101F	ML-110	1 90-90
Krilo FT-1120F	Sash FT-1120F	(ML/4)+46*	4 45-45
Krilo FT-1120F	Sash FT-1120F	MH-87	2 45-45
Krilo FT-1121F	Sash FT-1121F	MH-183	2 45-90
Prečka FT-1130F	Mullion FT-1130F	MH-66	2 90-90
Umetak rama FT-1132F	Frame insert FT-1132F	ML-64	1 90-90
Umetak krila FT-1030F	Frame insert FT-1030F	MH-87	1 90-90
Maska F-1538	Mask F-1538	MH-63.5	2 90-90
Maska F-1538	Mask F-1538	MH-87	2 90-90
Maska praga F-1536	Threshold mask F-1536	ML-2Lpreč-10	1 90-90
Maska praga F-1418	Threshold mask F-1418	ML-108	1 90-90
Vanjska st lajsna F-1419	Exterior glazing bead F-1419	Lpreč-100	2 90-90
Al vodilica F-1112 (elox)	Al guide F-1112 (elox)	ML-76	1 90-90
Maska F-1537	Mask F-1537	ML-2Lpreč-10	1 90-90
Staklo lajsna Z40-664	Glazing bead Z40-664	Lkr-94	4 90-90
Staklo lajsna Z40-664	Glazing bead Z40-664	Hkr-186	4 90-90
Staklo lajsna Z40-664	Glazing bead Z40-664	Lpreč-56	4 90-90
Staklo lajsna Z40-664	Glazing bead Z40-664	MH-107	4 90-90
Kutna spojnica 710.402	Corner bracket 710.402		4
Kutna spojnica 710.401	Corner bracket 710.401		4
Kutna spojnica 710.403	Corner bracket 710.403		4
Kutna spojnica 710.404	Corner bracket 710.404		4
Kutna spojnica 731.010	Corner bracket 731.010		8
Kutna spojnica 730.017	Corner bracket 730.017		8
Čep maske krila donji 373.051 (lijevi)	Cap mask on sash-lower 373.051 (left)		1
Čep maske krila donji 373.052 (desni)	Cap mask on sash-lower 373.052 (right)		1
Čep maske krila gornji 373.053	Cap mask on sash-upper 373.053		2
Usmjerivač krila 373.078	Sash guide 373.078		8
Umetak za odvod vode iz krila 360.009	Insert for sash drainage 360.009		4
Odbojnik na krilu 345.010	Sash bumper 345.010		4
Čep profila malog krila FT-1121 363.052	Cap for small sash profile FT-1121 363.052		2 par
Čep prečke 363.053 (lijevi)	Mullion cap 363.053 (left)		1
Čep prečke 363.054 (desni)	Mullion cap 363.054 (right)		1
Čep za profil FT-1030 363.030	Profile cap FT-1030 363.030		1 par
Čep prečke gornji 373.069	Mullion cap-upper 373.069		1
Šet umetaka za spoj rama 373.070	Set of inserts for frame connection 373.089		1
Čep prečke gornji 373.074	Mullion cap-upper 373.074		1
Pvc profil 374.120	Pvc profile 374.120	MH-63.5	2 90-90
Pvc profil 374.120	Pvc profile 374.120	MH-87	2 90-90
Brtva krila 327.003	Sash gasket 327.003		2Lkr+2Hkr
Brtva u gornj.horiz.pojasu krila 348.067	Upper horizontal sash zone gasket 348.067		2 Lkr
Brtva u gornj.horiz.pojasu krila 348.109 <sup>X</sup>	Upper horizontal sash zone gasket 348.109 <sup>X</sup>		2 Lkr
Brtva u donjem pojasu krila 348.079	Lower sash zone gasket 348.079		2Lkr
Brtva u pragu ispod krila 348.061	Threshold gask. under mask 348.061	ML-66	1 90-90
Brtva u pragu u fiksnom dijelu 348.081	Threshold gasket-fixed part 348.081	Lpreč-48	2 90-90
Brtva ispod maske u pragu 344.080	Threshold gask. under mask 344.080	ML-2Lpreč.-10	1 90-90
Brtva na spoju krila i fiksnog 344.113	Gasket on sash-fixed joint 344.113	MH-63.5	2 90-90
Brtva na spoju krila i fiksnog 344.113	Gasket on sash-fixed joint 344.113	MH-87	2 90-90
Brtva prema staklu /vanjska/ 328.002	Gasket to the glass /exterior/ 328.002		4Lkr+4Hkr+4Lfix+4MH
Brtva prema staklu /unut./ 311.004	Gasket to the glass /interior/ 311.004		4Lkr+4Hkr+4Lfix+4MH
Brtva 347.012	Gasket 347.012		(ML/2)+4MH+4Hkr
Izolacijski umetak po obodu stakla 340.013	Insulation insert along glass edge 340.013		4(Lkr-86)+4(Hkr-156) +4(Lpreč-46)+4(MH-83)
Izolacijski umetak 340.131	Insulation insert 340.131		4Hkr
Izolacijski umetak 340.129	Insulation insert 340.129		ML-2Lpreč-10
Umetak na spoju dva krila- 340.137	Insert on two sash joint-brushes 340.137		2

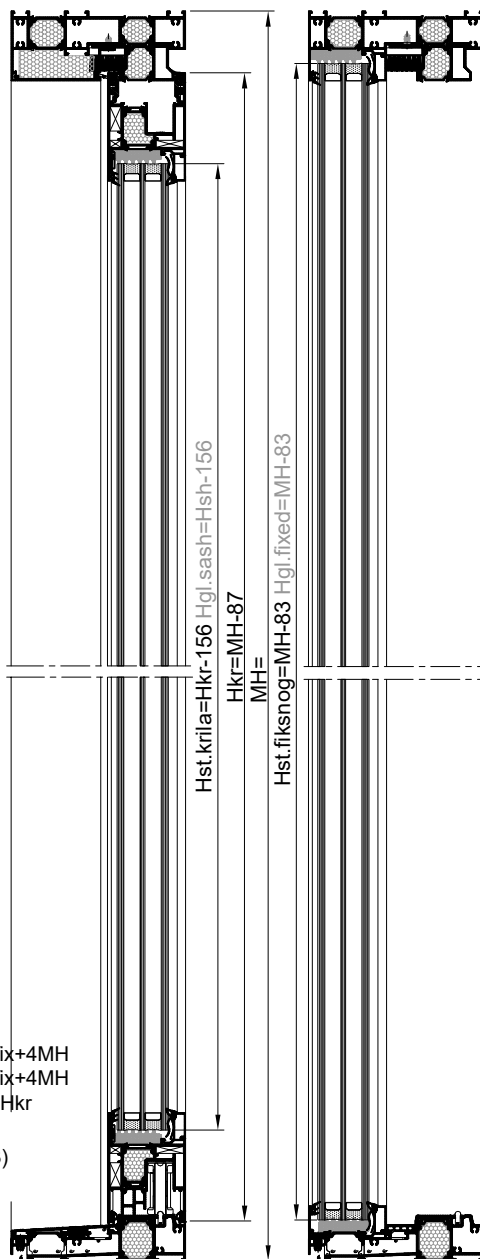
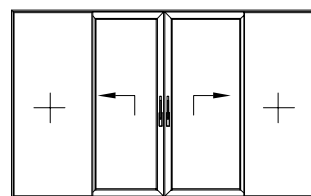

Izbor kovaka i ručaka za podizno klizni mehanizam 406.08.06 Selection of hardware and handles for L&S hardware 406.08.06  
X-brtva-opcija (za pozicije izložene udarima padalina) X-gasket-options (for positions exposed to rainfall)

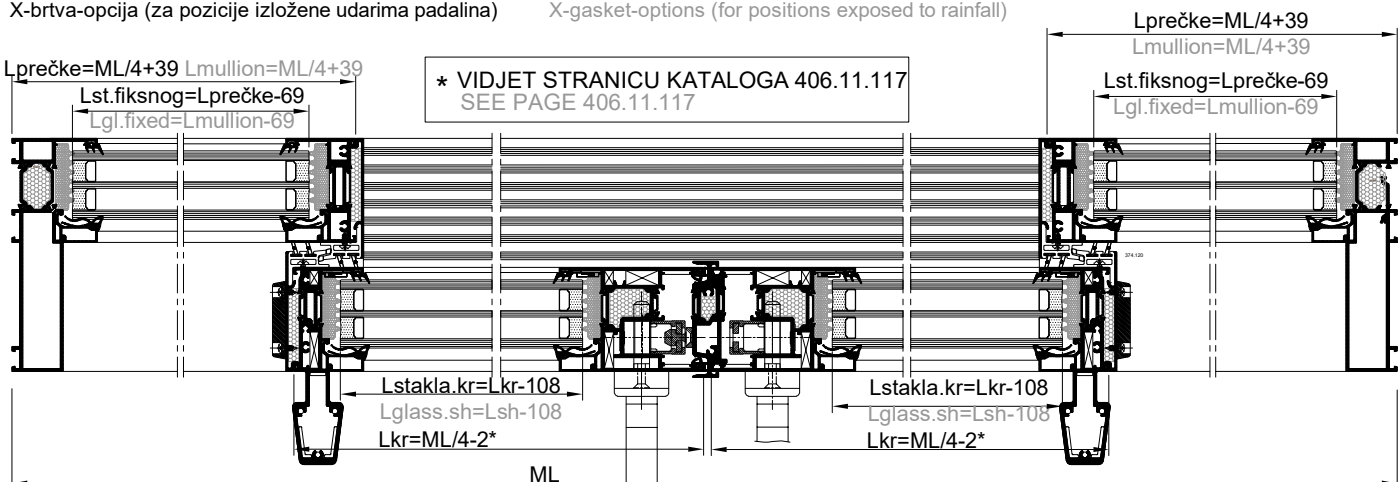

\* VIDJET STRANICU KATALOGA 406.11.117  
SEE PAGE 406.11.117

naziv name	mjera measure	kom. pcs.	pilanje cutting	
Okomica rama FT-1103F	Frame vertical FT-1103F	MH	2	90-90
Vodoravnica rama-donja FT-1102F	Frame horizontal-lower FT-1102F	ML-76	1	90-90
Vodoravnica rama-gornja FT-1101F	Frame horizontal-upper FT-1101F	ML-110	1	90-90
Krilo FT-1120F	Sash FT-1120F	ML1/2+8.5	2	45-45
Krilo FT-1120F	Sash FT-1120F	MH-87	2	45-45
Prečka FT-1131F	Mullion FT-1131F	MH-85	1	90-90
Prečka FT-1135F	Mullion FT-1135F	MH-54.5	1	90-90
Umetak rama FT-1132F	Frame insert FT-1132F	ML-(Lprečke1 +43)	1	90-90
Maska F-1538	Mask F-1538	MH-63.5	1	90-90
Maska F-1538	Mask F-1538	MH-87	1	90-90
Maska praga F-1536	Threshold mask F-1536	ML1-Lpreč.-31	1	90-90
Maska praga F-1418	Threshold mask F-1418	ML-59	1	90-90
Vanjska st lajsna F-1419	Exterior glazing bead F-1419	Lpreč.-148	1	90-90
Vanjska st lajsna F-1419	Exterior glazing bead F-1419	Lpreč.1-110	1	90-90
Al vodilica F-1112 (elox)	Al guide F-1112 (elox)	ML1-64	1	90-90
Maska F-1537	Mask F-1537	ML1-Lpreč.-31	1	90-90
Maska F-1542	Mask F-1542	Lpreč.1-59	1	90-90
Maska F-1539	Mask F-1539	MH-80	1	90-90
Maska F-1434	Mask F-1434	MH-85	1	90-90
Staklo lajsna Z40-664	Glazing bead Z40-664	Lkr-142	2	90-90
Staklo lajsna Z40-664	Glazing bead Z40-664	Hkr-186	2	90-90
Staklo lajsna Z40-664	Glazing bead Z40-664	Lpreč-104	2	90-90
Staklo lajsna Z40-664	Glazing bead Z40-664	MH-107	3	90-90
Staklo lajsna Z40-664	Glass glazing bead Z40-664	Lpreč.1-59	2	90-90

Kutna spojnica 710.401	Corner bracket 710.401		4	
Kutna spojnica 710.403	Corner bracket 710.403		4	
Kutna spojnica 731.010	Corner bracket 731.010		4	
Kutna spojnica 730.017	Corner bracket 730.017		8	
Čep maske krila donji 373.051 (lijevi)	Cap mask on sash-lower 373.051 (left)		1	
Čep maske krila gornji 373.053	Cap mask on sash-upper 373.053		1	
Usmjerivač krila 373.078	Sash guide 373.078		4	
Umetak za odvod vode iz krila 360.009	Insert for sash drainage 360.009		2	
Odbojnik na krilu 345.010	Sash bumper 345.010		2	
Čep za donji spoj prečke 363.060	Cap for lower frame joint 363.060		1	
Čep prečke donji 373.067	Mullion cap-lower 373.067		1	
Čep prečke gornji 373.068	Mullion cap-upper 373.068		1	
Set umetaka za spoj rama 373.089	Set of inserts for frame connection 373.089		1	

Pvc profil 374.083	Pvc profile 374.083	MH-63.5	1	90-90
Pvc profil 374.083	Pvc profile 374.083	MH-87	1	90-90

Brtva krila 327.003	Sash gasket 327.003		2Lkr+2Hkr	
Brtva u gornj. horiz. pojasu krila 348.067	Upper horiz. sash zone gasket 348.067		Lkr	
Brtva u gornj. horiz. pojasu krila 348.109 <sup>X</sup>	Upper horiz. sash zone gasket 348.109 <sup>X</sup>		Lkr	
Brtva u donjem pojasu krila 348.079	Lower sash zone gasket 348.079		Lkr	
Brtva u pragu ispod krila 348.061	Under sash threshold gasket 348.061	ML1-74	1	90-90
Brtva u pragu u fiks. dijelu 348.081	Threshold gasket-fixed part 348.081	Lpreč1-78	1	90-90
Brtva ispod maske u pragu 344.080	Threshold gask. under mask 344.080	ML1-Lpreč-31	1	90-90
Brtva ispod maske u pragu 344.080	Threshold gask. under mask 344.080	Lpreč.1-59	1	90-90
Brtva na spoju krila i fiksnog 344.113	Gasket on sash-fixed joint 344.113	MH-63.5	1	90-90
Brtva na spoju krila i fiksnog 344.113	Gasket on sash-fixed joint 344.113	MH-87	1	90-90

Brtva prema staklu /vanjska/ 328.002	Gasket to the glass /ext./ 328.002		2Lkr+2Hkr+2Lpreč1+2Lpreč+4MH	
Brtva prema staklu /unut./ 311.004	Gasket to the glass /inter./ 311.004		2Lkr+2Hkr+2Lpreč1+2Lpreč+4MH	

Brtva ispod maske F-1539 358.017	Gasket under mask F-1539 358.017		Lkr	
----------------------------------	----------------------------------	--	-----	--

Brtva 347.012	Gasket 347.012	(ML/2)+3MH+2Hkr		
---------------	----------------	-----------------	--	--

Izolacijski umetak po obodu stakla 340.013	Insulation insert along glass edge 340.013		2(Lkr-132)+2(Hkr-156)	
--	--	--	-----------------------	--

Izolacijski umetak 340.130	Insulation insert 340.130		1Hkr	
----------------------------	---------------------------	--	------	--

Izolacijski umetak 340.131	Insulation insert 340.131		1Hkr	
----------------------------	---------------------------	--	------	--

Izolacijski umetak 340.129	Insulation insert 340.129		ML1-Lpreč1-31	
----------------------------	---------------------------	--	---------------	--

Umetak na spoju dva krila-340.136	Insert on two sash joint-brushes 340.136		1	
-----------------------------------	--	--	---	--

Izolacijski umetak 340.132	Insulation insert 340.132		MH-80	
----------------------------	---------------------------	--	-------	--

Izbor okova i ručaka za podizno klizni mehanizam 406.08.06	Selection of hardware and handles for L&S hardware 406.08.06			
--	--	--	--	--

X-brtva-opcija (za pozicije izložene udarima padalina)	X-gasket-options (for positions exposed to rainfall)			
--	--	--	--	--

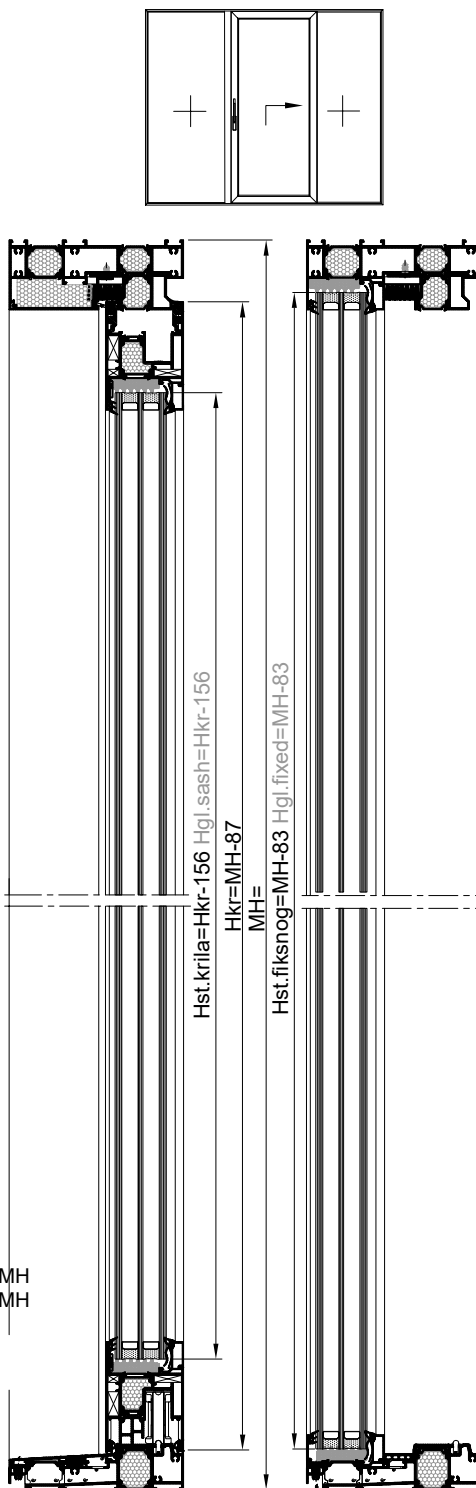
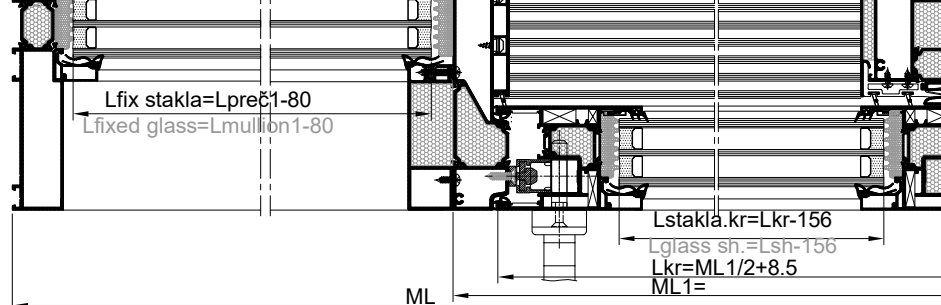

naziv name	mjera measure	kom. pcs.	pilanje cutting	
Okomica rama FT-1103F	Frame vertical FT-1103F	MH	2	90-90
Vodoravnica rama-donja FT-1102F	Frame horizontal-lower FT-1102F	ML-76	1	90-90
Vodoravnica rama-gornja FT-1101F	Frame horizontal-upper FT-1101F	ML-110	1	90-90
Krilo FT-1120F	Sash FT-1120F	(ML/2)+32.5*	2	45-45
Krilo FT-1120F	Sash FT-1120F	MH-87	1	45-45
Krilo FT-1121F	Sash FT-1121F	MH-87	1	45-45
Prečka FT-1130F	Mullion FT-1130F	MH-66	1	90-90
Prečka FT-1135F	Mullion FT-1135F	MH-54.5	1	90-90
Umetak rama FT-1132F	Frame insert FT-1132F	ML-(Lprečke1+43)	1	90-90
Maska F-1538	Mask F-1538	MH-63.5	1	90-90
Maska F-1538	Mask F-1538	MH-87	1	90-90
Maska praga F-1536	Threshold mask F-1536	ML1-Lpreč.-31	1	90-90
Maska praga F-1418	Threshold mask F-1418	ML-59	1	90-90
Vanjska st lajsna F-1419	Exterior glazing bead F-1419	Lpreč.-99.5	1	90-90
Vanjska st lajsna F-1419	Exterior glazing bead F-1419	Lpreč.1-110	1	90-90
Al vodilica F-1112 (elox)	Al guide F-1112 (elox)	ML1-64	1	90-90
Maska F-1537	Mask F-1537	ML1-Lpreč.-31	1	90-90
Maska F-1542	Mask F-1542	Lpreč.1-59	1	90-90
Maska F-1539	Mask F-1539	MH-80	1	90-90
Maska F-1434	Mask F-1434	MH-85	1	90-90
Staklo lajsna Z40-664	Glazing bead Z40-664	Lkr-94	2	90-90
Staklo lajsna Z40-664	Glazing bead Z40-664	Hkr-186	2	90-90
Staklo lajsna Z40-664	Glazing bead Z40-664	Lpreč-56	2	90-90
Staklo lajsna Z40-664	Glazing bead Z40-664	MH-107	3	90-90
Staklo lajsna Z40-664	Glazing bead Z40-664	Lpreč.1-59	2	90-90
Kutna spojnica 710.402	Corner bracket 710.402		2	
Kutna spojnica 710.401	Corner bracket 710.401		2	
Kutna spojnica 710.403	Corner bracket 710.403		2	
Kutna spojnica 710.404	Corner bracket 710.404		2	
Kutna spojnica 731.010	Corner bracket 731.010		8	
Kutna spojnica 730.017	Corner bracket 730.017		8	
Čep maske krila donji 373.051 (lijevi)	Cap mask on sash-lower 373.051 (left)		1	
Čep maske krila gornji 373.053	Cap mask on sash-upper 373.053		1	
Usmjerivač krila 373.078	Sash guide 373.078		4	
Umetak za odvod vode iz krila 360.009	Insert for sash drainage 360.009		2	
Odbojnik na krilu 345.010	Sash bumper 345.010		2	
Čep prečke 363.053 (lijevi)	Mullion cap 363.053 (left)		1	
Čep za donji spoj prečke 363.060	Cap for lower frame joint 363.060		1	
Čep prečke donji 363.053	Mullion cap-lower 363.053		1	
Čep prečke gornji 373.069	Mullion cap-upper 373.069		1	
Set umetaka za spoj rama 373.070	Set of inserts for frame connection 373.070		1	
Pvc profil 374.120	Pvc profile 374.120	MH-63.5	1	90-90
Pvc profil 374.120	Pvc profile 374.120	MH-87	1	90-90
Brtva krila 327.003	Sash gasket 327.003		2Lkr+2Hkr	
Brtva u gornj. horiz.pojasu krila 348.067	Upper horiz. sash zone gasket 348.067		Lkr	
Brtva u gornj. horiz.pojasu krila 348.109 <sup>X</sup>	Upper horiz. sash zone gasket 348.109 <sup>X</sup>		Lkr	
Brtva u donjem pojasu krila 348.079	Lower sash zone gasket 348.079		Lkr	
Brtva u pragu ispod krila 348.061	Under sash threshold gasket 348.061	ML1-74	1	90-90
Brtva u pragu u fiksnoj dijelu 348.081	Threshold gasket-fixed part 348.081	Lpreč1-78	1	90-90
Brtva ispod maske u pragu 344.080	Threshold gasket under mask 344.080	ML1-Lpreč-31	1	90-90
Brtva ispod maske u pragu 344.080	Threshold gasket under mask 344.080	Lpreč.1-59	1	90-90
Brtva na spoju krila i fiksnog 344.113	Gasket on sash-fixed joint 344.113	MH-63.5	1	90-90
Brtva na spoju krila i fiksnog 344.113	Gasket on sash-fixed joint 344.113	MH-87	1	90-90
Brtva prema staklu /vanjska/ 328.002	Gasket to the glass /exterior/ 328.002		2Lkr+2Hkr+2Lpreč1+2Lpreč+4MH	
Brtva prema staklu /unutarnja/ 311.004	Gasket to the glass /interior/ 311.004		2Lkr+2Hkr+2Lpreč1+2Lpreč+4MH	
Brtva ispod maske F-1539 358.017	Gasket under mask F-1539 358.017		Lkr	
Izolacijski umetak po obodu stakla 340.013	Insulation insert along glass edge 340.013		(ML/2)+3MH+2Hkr	
Izolacijski umetak 340.130	Insulation insert 340.130		2(Lkr-86)+2(Hkr-156)	
Izolacijski umetak 340.131	Insulation insert 340.131		+(2Lpreč.+2Lpreč.1)+4(MH-83)	
Izolacijski umetak 340.129	Insulation insert 340.129		1Hkr	
Umetak na spoju dva krila- 340.137	Insert on two sash joint-brushes 340.137		1Hkr	
Izolacijski umetak 340.132	Insulation insert 340.132		ML1-Lpreč1-31	
Izbor okova i ručaka za podizno klizni mehanizam 406.08.06	Selection of hardware and handles for L&S hardware 406.08.06		1	
X-brtva-opcija (za pozicije izložene udarima padalina)	X-gasket-options (for positions exposed to rainfall)		MH-80	

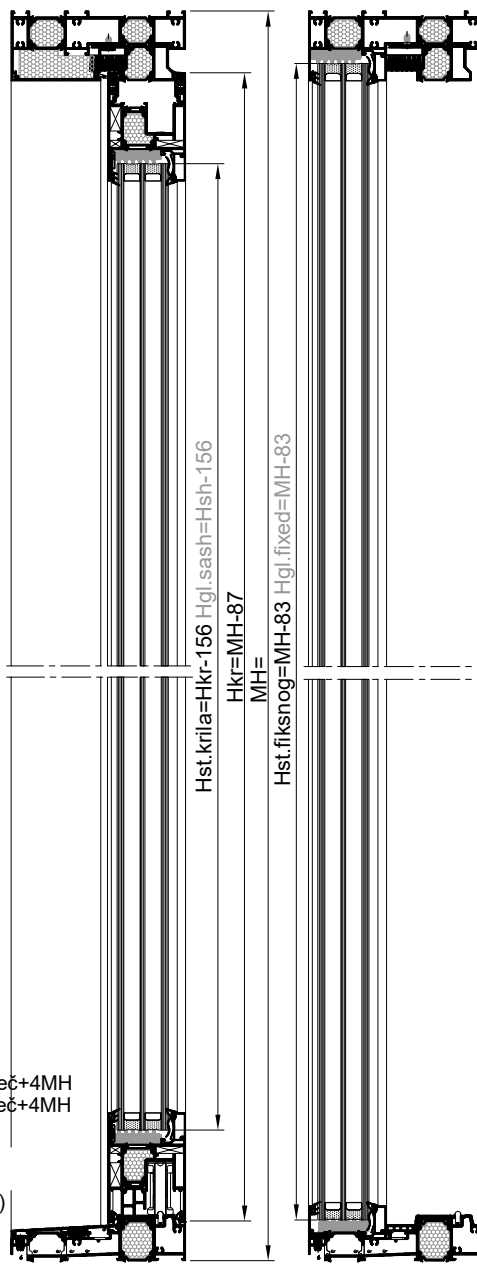
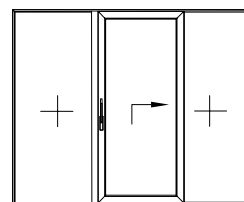

\* VIDJET STRANICU KATALOGA 406.11.117  
SEE PAGE 406.11.117

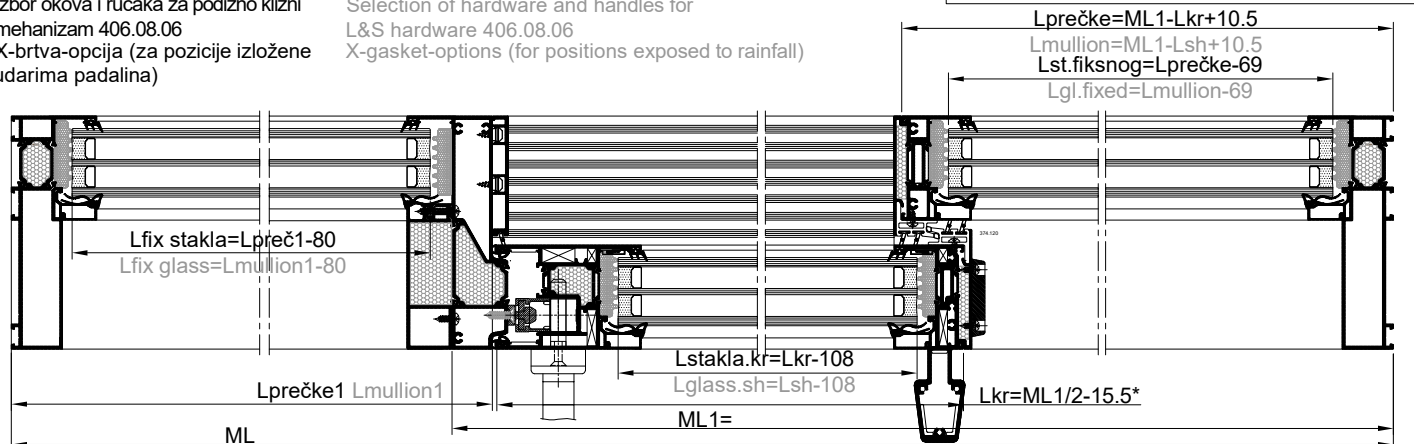





# FEAL



Skenirajte QR kod i registrirajte se na [partner.feal.ba](https://partner.feal.ba)

*Scan the QR code and register on [partner.feal.ba](https://partner.feal.ba)*

## TERMO 150

Knjiga B / *Book B*

Lipanj 2021 / *June 2021*

FEAL d.o.o.  
Trnska cesta 146  
88220 Široki Brijeg  
Bosna i Hercegovina  
Tel. +387 39 704-269; 705-807; 705-636  
Fax. +387 39 704-358  
[info@feal.ba](mailto:info@feal.ba)  
[www.feal.ba](http://www.feal.ba)