

FEAL

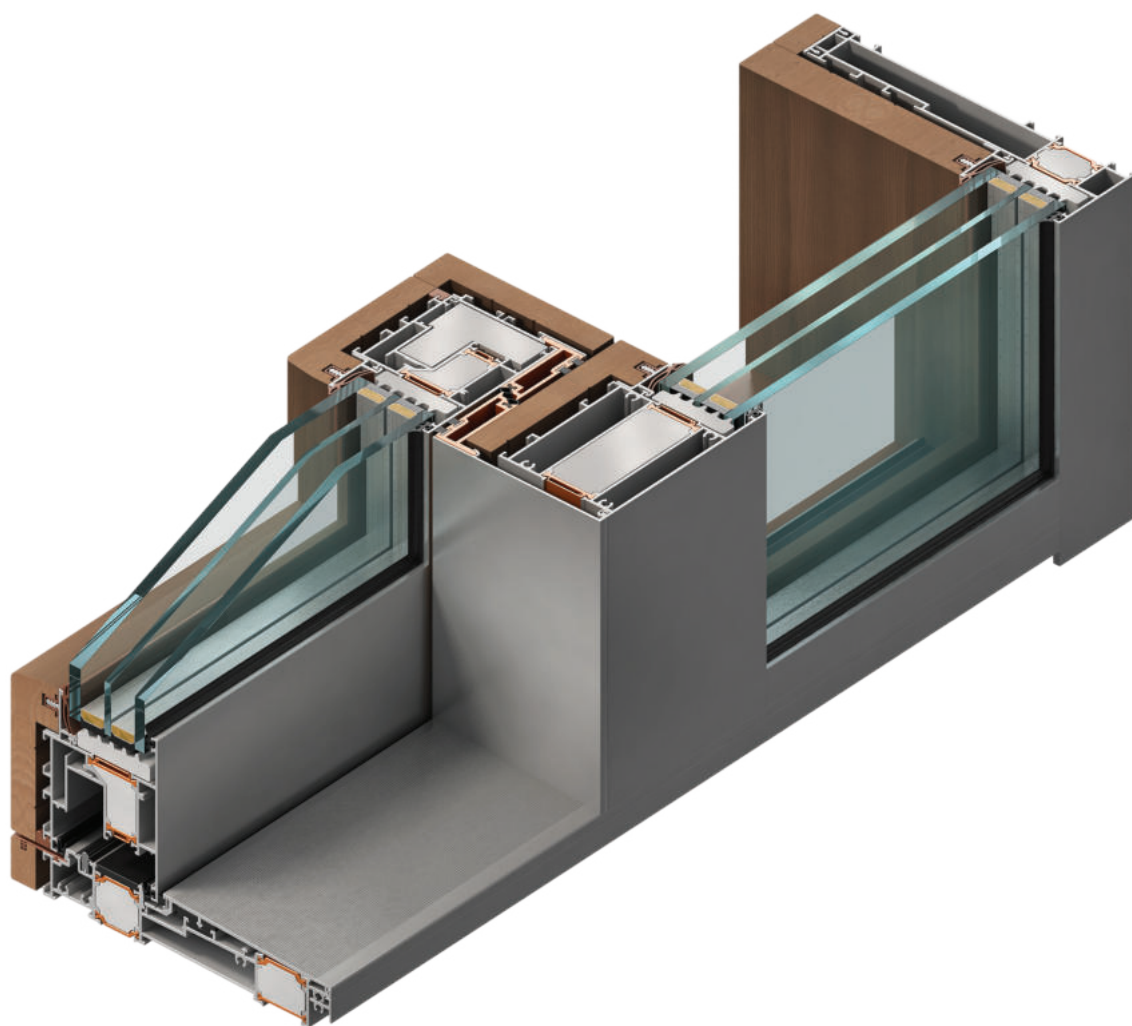

TERMO 200 DA

PODIZNO-KLIZNI SISTEM

LIFT & SLIDE SYSTEM

SADRŽAJ CONTENT

00	ZNAČAJKE SISTEMA	407.00.000-003
00	SYSTEM CHARACTERISTICS	407.00.000-003
01	ISPITIVANJA I CERTIFIKATI	407.01.000-003
01	TESTING AND CERTIFICATES	407.01.000-003
02	DIJAGRAM VELIČINA	407.01.000-009
02	DIMENSIONS CHART	407.01.000-009
03	PROFILI	407.03.000-015
03	PROFILES	407.03.000-015
04	VEZNI ELEMENTI	407.04.000-003
04	CONNECTION ELEMENTS	407.04.000-003
05	PVC ELEMENTI	407.05.000-005
05	PVC ELEMENTS	407.05.000-005
06	MEHANIZMI	407.06.000-011
06	MECHANISMS	407.06.000-011
07	BRTVILA	407.07.000-005
07	GASKETS	407.07.000-005
08	DODACI	407.08.000-005
08	ACCESSORIES	407.08.000-005
09	PRESJECI	407.09.000-027
09	CROSS SECTIONS	407.09.000-027
10	OBRADA I MONTAŽA	407.10.000-054
10	PROCESSING AND MONTAGE	407.10.000-054
11	REZNE LISTE	407.11.000-009
11	CUTTING LISTS	407.11.000-009

Značajke sistema

System characteristics

PODIZNO - KLIZNI SISTEM VRATA LIFT AND SLIDE DOOR SYSTEM

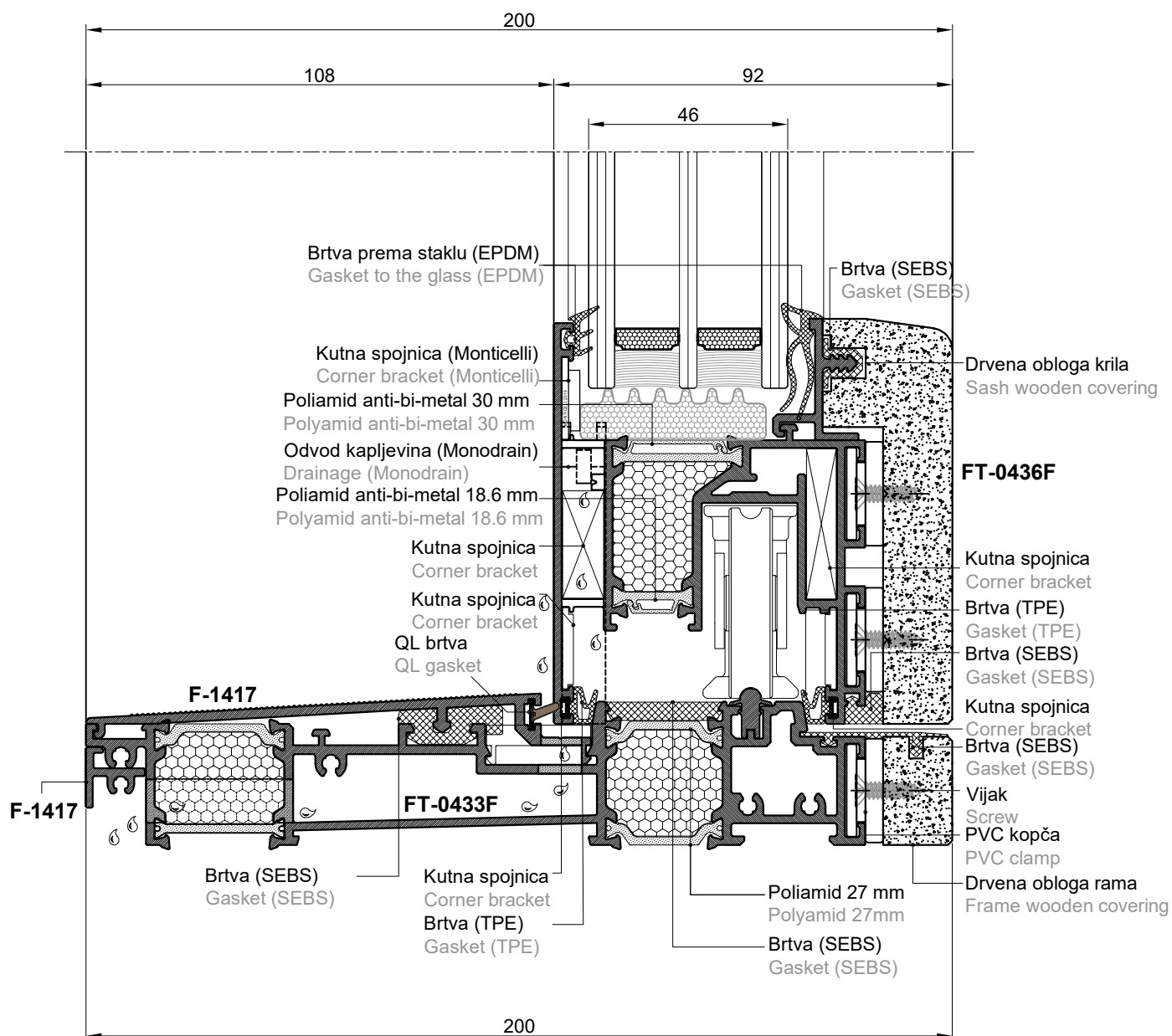

OPIS SISTEMA TERMO 200 DA / DESCRIPTION OF SYSTEM TERMO 200 DA

- Sistem TERMO 200 DA koristi se za izradu podizno - kliznih vrata (jedno krilo podizno klizno+fiksno, dva srednja krila podizno klizna bokovi fiksni, bokovi podizno klizna krila a sredina fiksna).
- System TERMO 200 DA is used for making lift and slide doors (single sash lift&slide + fixed, double central sashes lift & slide with side profile fixed and lift&slide sash on side with central fixed part).
- Profil rama i krila sastoji se iz:
vanjskog al. profila + poliamidne trake + unutarnjeg al. profila i drvene obloge
drvenu oblogu spajamo s pripadajućim profilom pomoću kopči.
- Profiles of sash and frame are consisted of:
exterior al. profile + polyamide bar + interior al. profile and wooden covering
wooden covering is connected to the adequate al. profile with clamps.
- Profili su izvedeni s prekinutim toplinskim mostom osnovne ugradbene dubine:
ram 200 mm i krilo 92 mm.
- Profiles are made with thermal bridge with main mounting depth of:
frame 200 mm and sash 92 mm.
- Prekid toplinskog mosta postiže se poliamidnim trakama (27 mm i 30 mm za ram i 18.6 mm i 30 mm za krilo (antibimetalni)).
- Thermal bridge break is accomplished with polyamide bars (27 mm i 30 mm for frame and 18.6 mm and 30 mm for sash (antibimetal)).
- Radi poboljšanja toplinskih karakteristika (smanjenja toplinske provodljivosti) u komore profila se ugrađuju trake od ekstrudiranog polistirena (XPS - a).
- For thermal characteristics improvement (reduction of thermal conductivity) into the profiles chambers extruded bars of polystyrene bars (XPS) are imbed.
- U kombinaciji s troslojnim staklom i odgovarajućim distancerom stakla sistem može postići ukupni koeficijent prolaska topline $U_d = 1$ [W/m²K].
- In combination of triple glazed windows and adequate glass spacer system can reach total heat transfer coefficient of $U_d = 1$ [W/m²K].
- Brtvljenje između krila i rama izvedeno je EPDM brtvama.
- Sealing between sash and frame is done with EPDM gaskets.
- Staklo je u krilu učvršćeno unutarnjim letvicama te zabrtvljeno EPDM brtvama s obje strane.
- Glass in the window is fastened with inner stripes and sealed with EPDM gaskets along both sides.
- Okov je sistematski (podizno - klizni) proizvođača Hautau.
- Hardware is systematic (lift and slide) manufactured by Hautau.

Karakteristika sistema: / System characteristics:

- Materijal /	Material	EN AW - 6060
- Masa krila /	Sash weight	150 - 300 kg
- Debljina stakla /	Glass thickness	46 mm
- Materijal za brtvljenje (EPDM) /	Sealing material (EPDM)	DIN 7863
- Zrakopropusnost /	Air permeability	Class 4
- Vodonepropusnost /	Watertightness	9A
- Otpornost na udar vjetra /	Resistance to wind	C4/B4
- Proračun U_d koeficijenta /	U_d coefficient calculation	DIN EN ISO 10077-2
- Površinska obrada /	Surface processing	DIN 17611
- Kontrola kvalitete /	Quality control	DIN EN ISO 9001

Ispitivanja i certifikati

Testing and certificates

ISPITIVANJA I CERTIFIKATI TEST AND CERTIFICATES			
Vrsta ispitivanja Type of test	Dvokrilna vrata Double casement door	Trokrlina vrata Triple casement door	Četverokrilna vrata Four casement door
Zrakopropusnost Air permeability EN12207	Class 4		
Vodonepropusnost Watertightness EN 12208	9A		
Vjetronepropusnost Resistance to wind EN 12210	C4/B4		
Buka Rw Airborne sound reduction EN ISO 717-1			
Protuprovalnost Protection against burglary EN 1627			
Otpornost na istezanje, torziju... Resistance at strain, torsion...			
Pendtl test Impact resistance test EN 13049			
Protupožarnost Fire resistance test DIN EN 1363-1			
Toplinska provodljivost vrata, u skladu s EN ISO 10077-1, je Uw=1.1 [W/m²K] Thermal conductivity doors, in accordant with EN ISO 10077-1, is Uw=1.1 [W/m²K]			

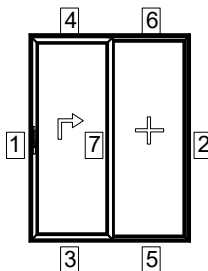
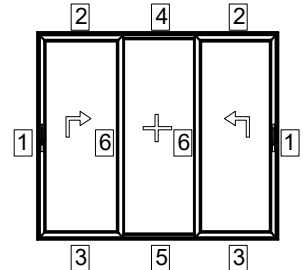
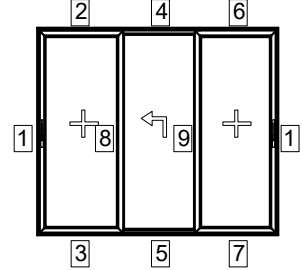
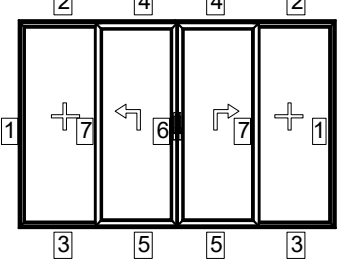
		Uf1 W/m ² K	Uf2 W/m ² K	Uf3 W/m ² K	Uf4 W/m ² K	Uf5 W/m ² K	Uf6 W/m ² K	Uf7 W/m ² K	Uf8 W/m ² K	Uf9 W/m ² K	Ug W/m ² K	Uw W/m ² K
	Termo 200 DA										0,7	≥1,1
	Dvokrilna vrata Double casement door (2600x2200)	1.9	1.5	1.8	2.1	1.5	1.6	2.9				*
	Termo 200 DA										0,7	≥1,1
	Trokrilna vrata Triple casement door (3900x2200)	1.9	2.1	1.8	1.6	1.5	2.9					*
	Termo 200 DA										0,7	≥1,1
	Trokrilna vrata Triple casement door (3900x2200)	1.5	1.6	1.5	2.1	1.8	1.4	1.5	2.9	3.0		*
	Termo 200 DA										0,7	≥1,0
	Četverokrilna vrata Four casement door (5200x2200)	1.5	1.6	1.5	2.1	1.8	1.8	2.9				*
		* 2,0	* 2,3	* 2,3	* 2,6	* 2,1	* 2,2	* 3,3			0,5	≥0,87
											*	≥0,96

Proračun koeficijenta prolaza topline
Calculation of thermal transmittance



<http://termika.feal.ba/>

* Uf i Uw izračuni bez XPS ispuna u profilima

* Uf and Uw calculations without XPS isolation in the profiles

Dijagram veličina Dimensions chart

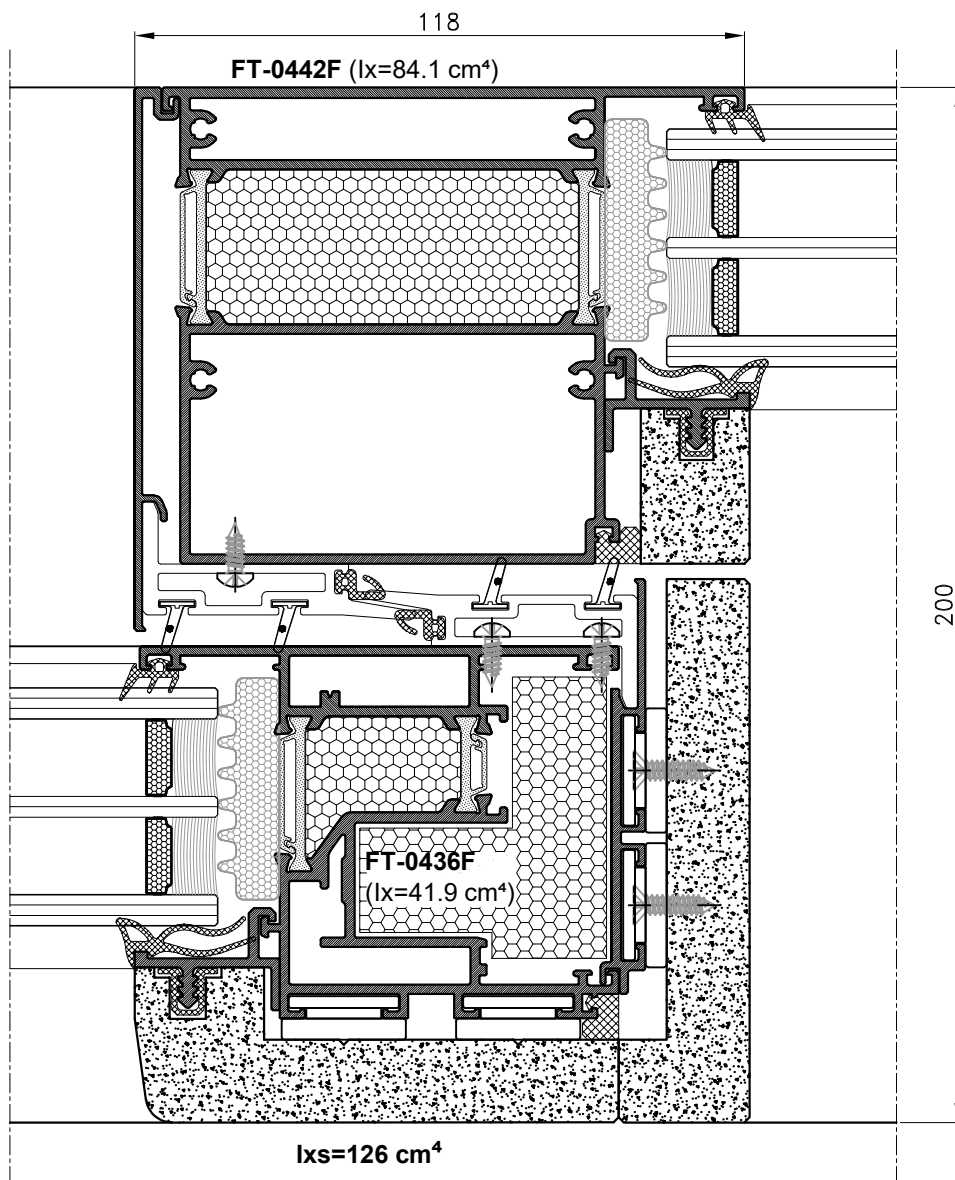

Max. omjer visine
i širine krila

$H:L \leq 2.5$

Max. sash
height/width ratio

$H:L \leq 2.5$

 Nije dopušteno
Not allowed

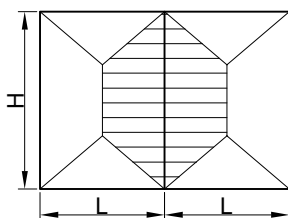

H= Visina krila
H= Sash height

L= Širina krila
L= Sash width

500 Pa ———

800 Pa ———

1200 Pa ———

2000 Pa ———

2400 Pa ———

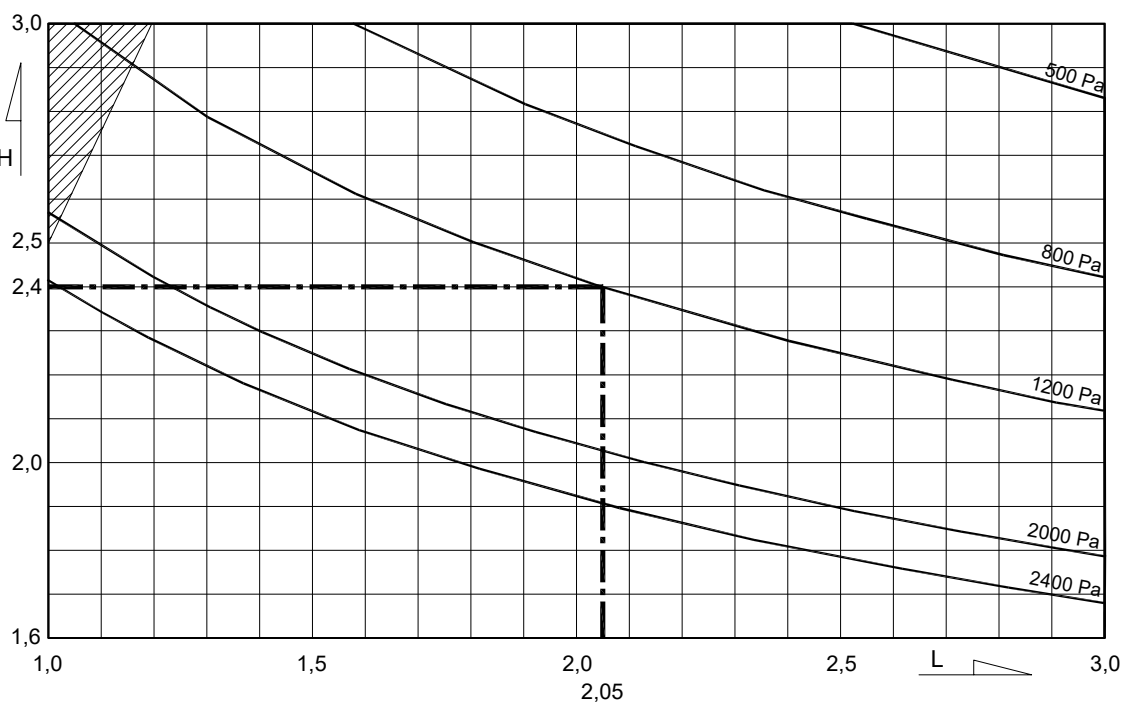

primjer: $H \times L = 2400 \times 2050$ (1200 Pa)

example: $H \times L = 2400 \times 2050$ (1200 Pa)

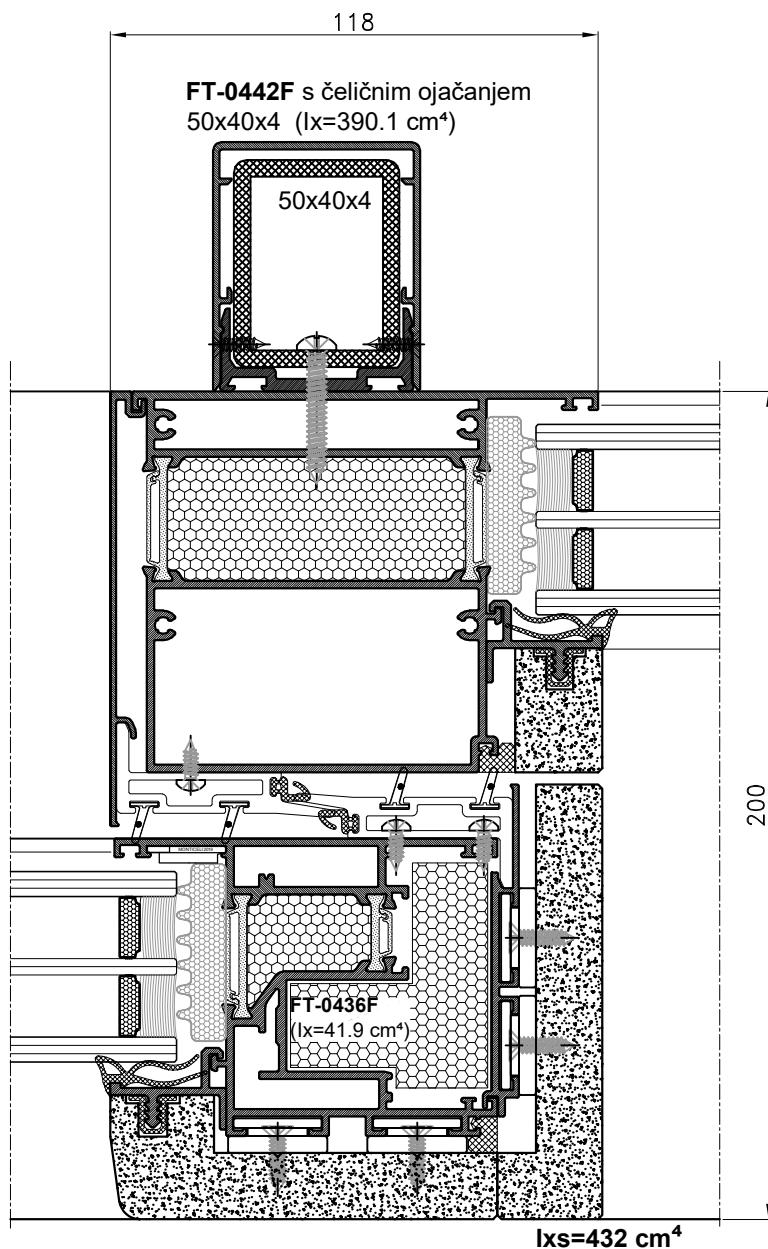

Max. omjer visine
i širine krila
 $H:L \leq 2.5$
Max. sash
height/width ratio
 $H:L \leq 2.5$

 Nije dopušteno
Not allowed

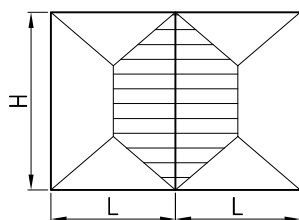

H= Visina krila
H= Sash height
L= Širina krila
L= Sash width

500 Pa ———
800 Pa ———
1200 Pa ———
2000 Pa ———
2400 Pa ———

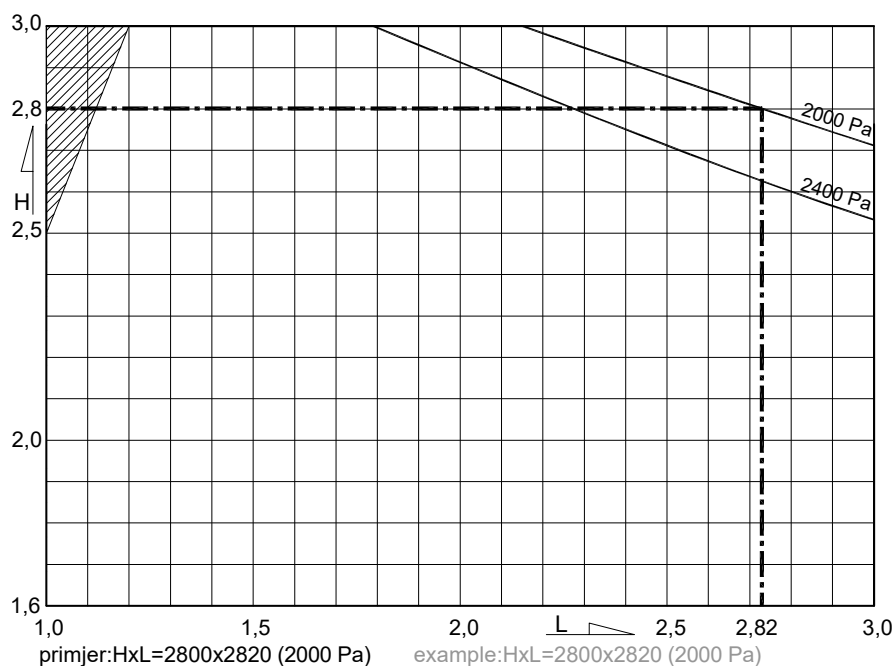

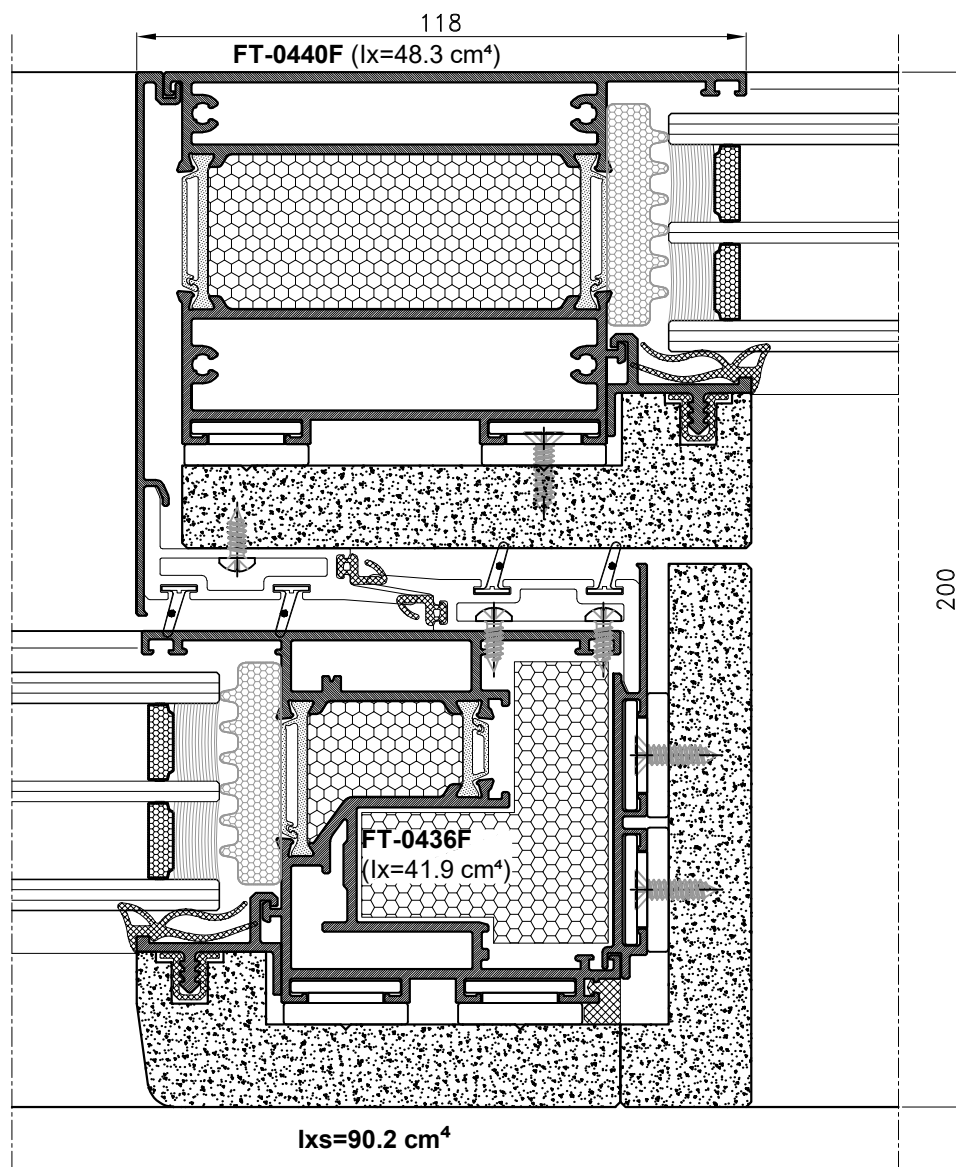

Max. omjer visine i širine krila
H:L ≤ 2.5

Max. sash height/width ratio
H:L ≤ 2.5

 Nije dopušteno
Not allowed

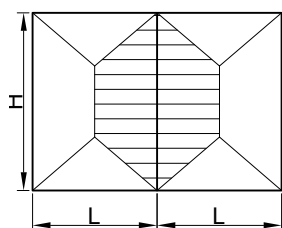

H= Visina krila
H= Sash height

L= Širina krila
L= Sash width

500 Pa ———
800 Pa ———
1200 Pa ———
2000 Pa ———
2400 Pa ———

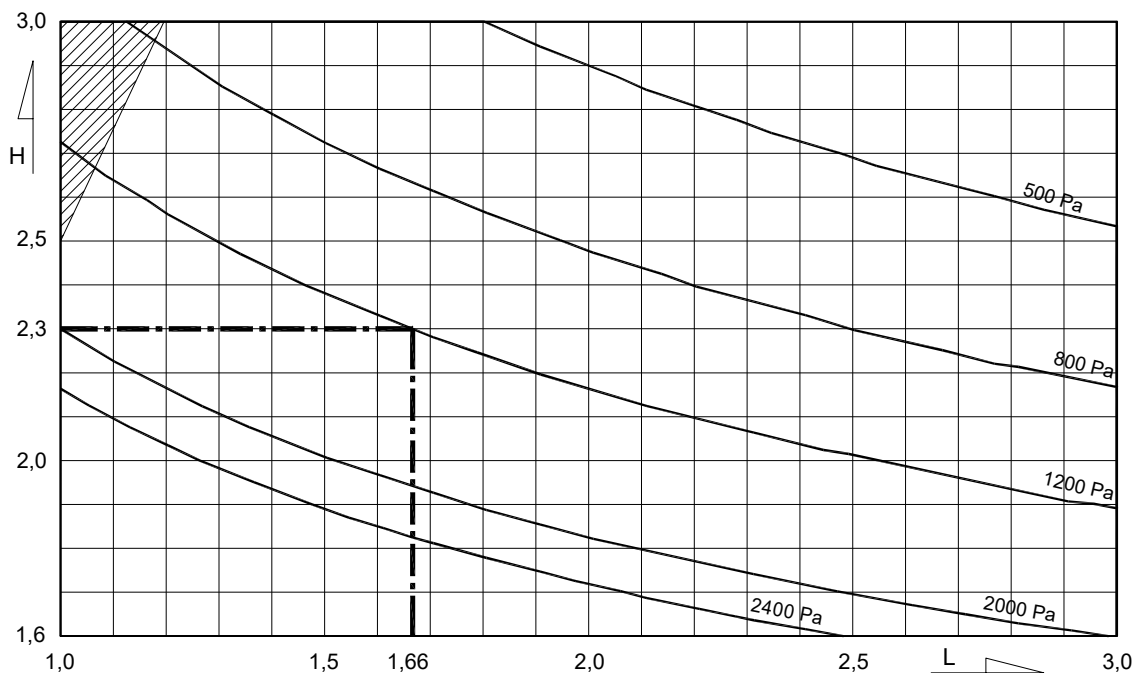

primjer: HxL=2300x1660 (1200 Pa)

example: HxL=2300x1660 (1200 Pa)

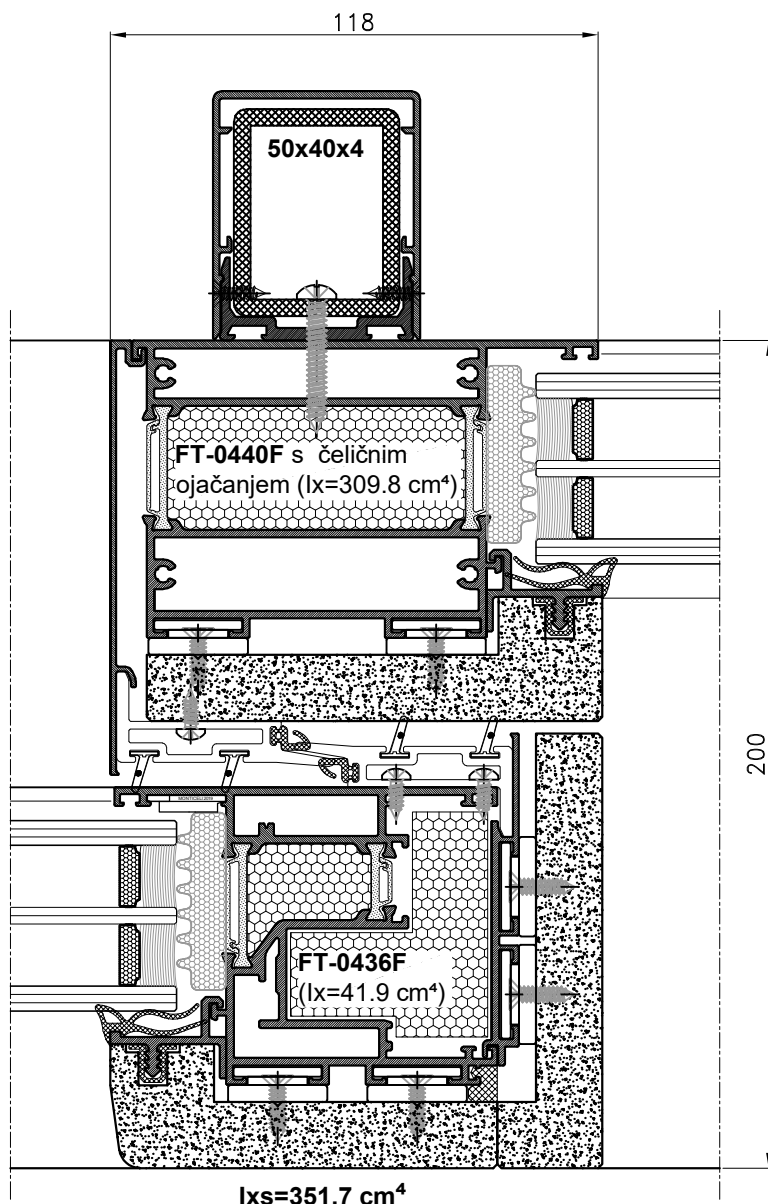

Max. omjer visine i širine krila

H:L ≤ 2.5

Max. sash height/width ratio

H:L ≤ 2.5

 Nije dopušteno
Not allowed

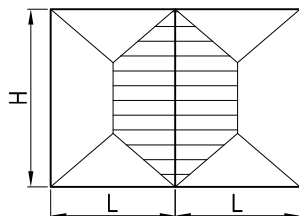

H= Visina krila
H= Sash height
L= Širina krila
L= Sash width

500 Pa ———
800 Pa ———
1200 Pa ———
2000 Pa ———
2400 Pa ———

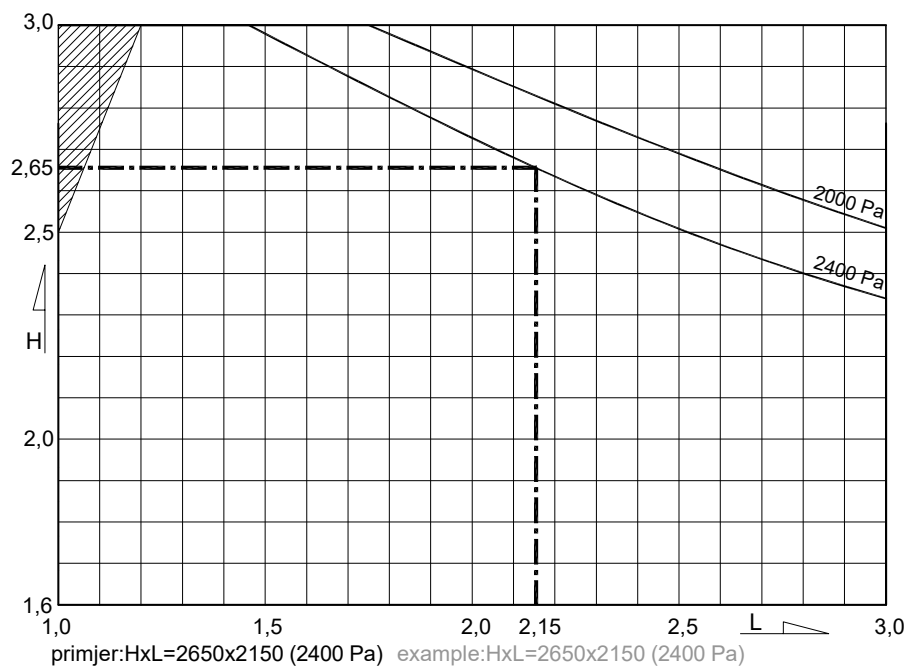

primjer: HxL=2650x2150 (2400 Pa) example: HxL=2650x2150 (2400 Pa)

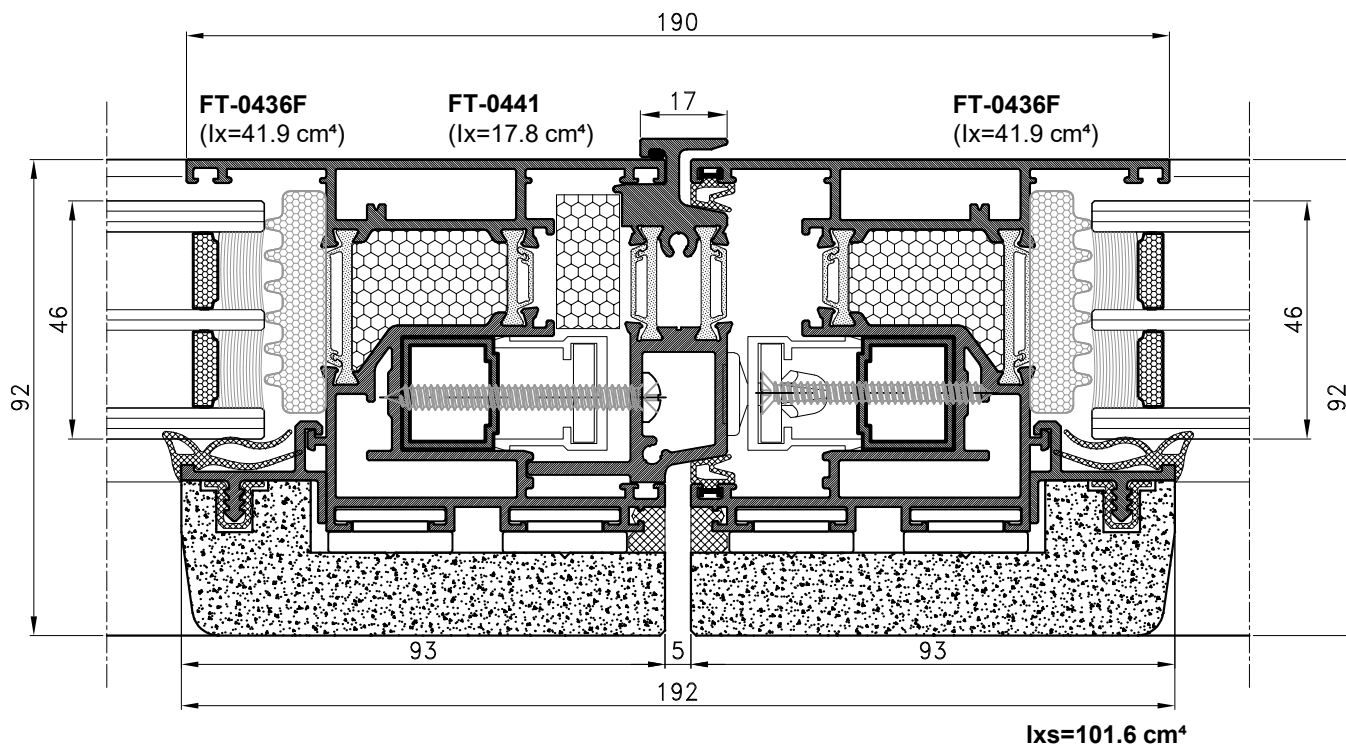

Max. omjer visine
i širine krila

H:L ≤ 2.5

Max. sash
height/width ratio

H:L ≤ 2.5

 Nije dopušteno
Not allowed

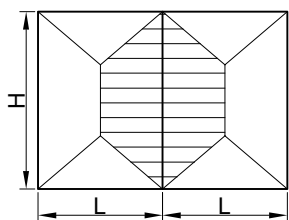

H= Visina krila
H= Sash height

L= Širina krila
L= Sash width

500 Pa

800 Pa

1200 Pa

2000 Pa

2400 Pa

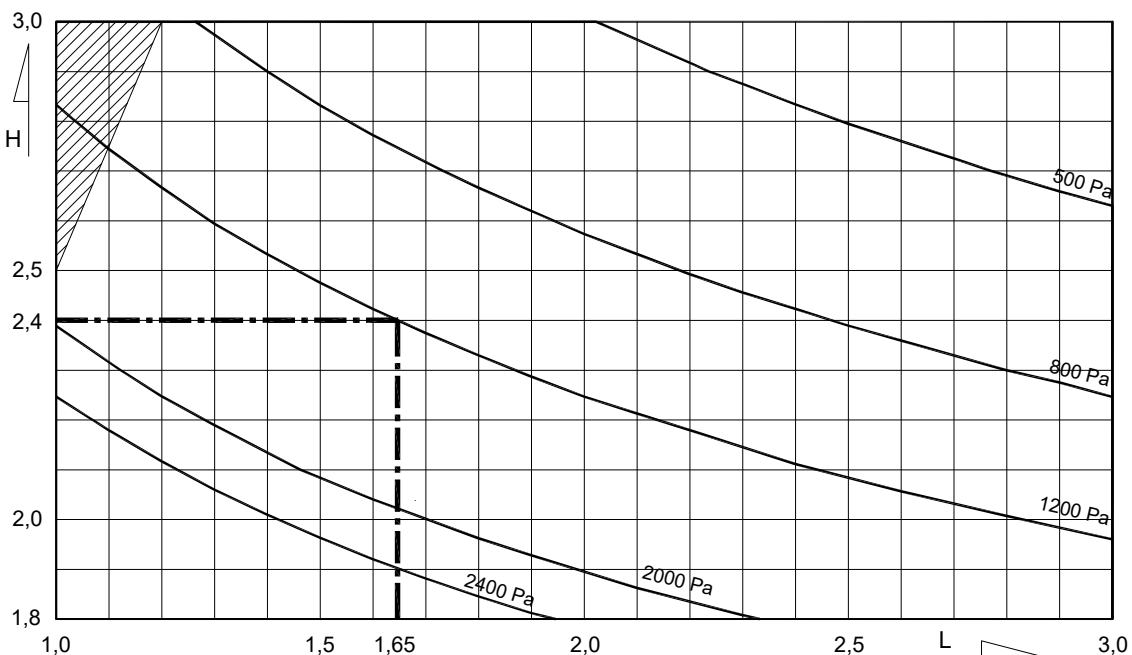

primjer:HxL=2400x1650(1200 Pa) example:HxL=2400x1650(1200 Pa)

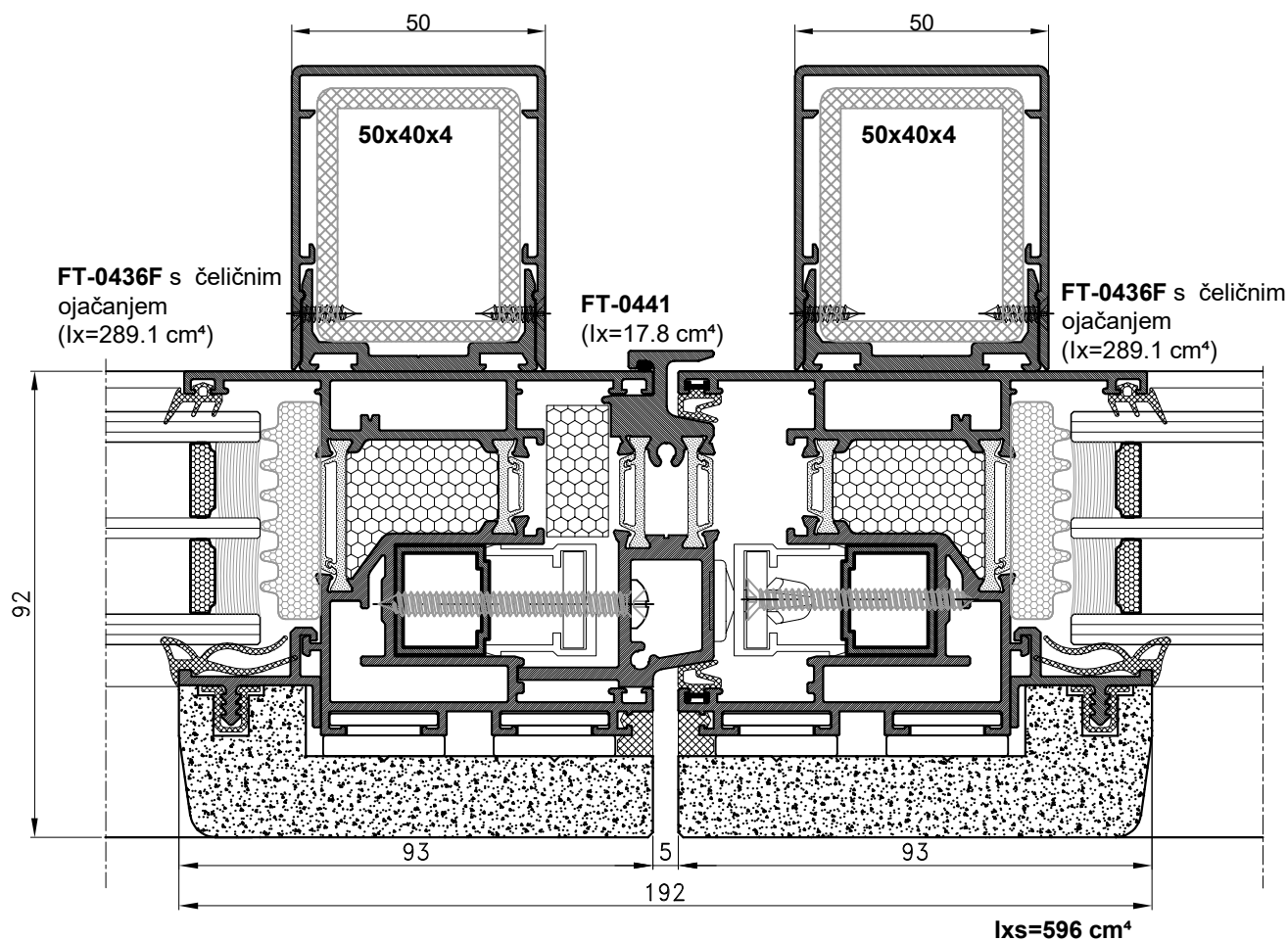

Max. omjer visine i širine krila
H:L ≤ 2.5

Max. sash height/width ratio
H:L ≤ 2.5

 Nije dopušteno
Not allowed

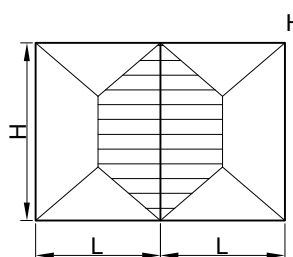

H= Visina krila
H= Sash height

L= Širina krila
L= Sash width

500 Pa

800 Pa

1200 Pa

2000 Pa

2400 Pa

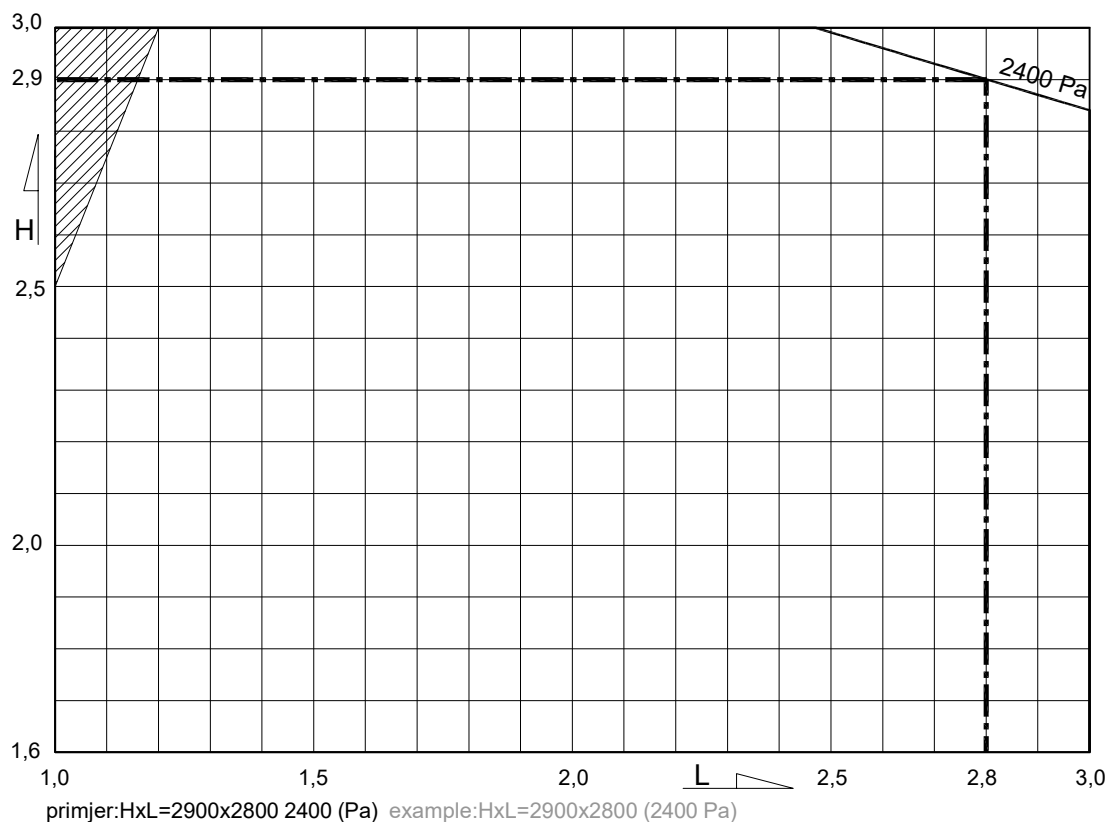

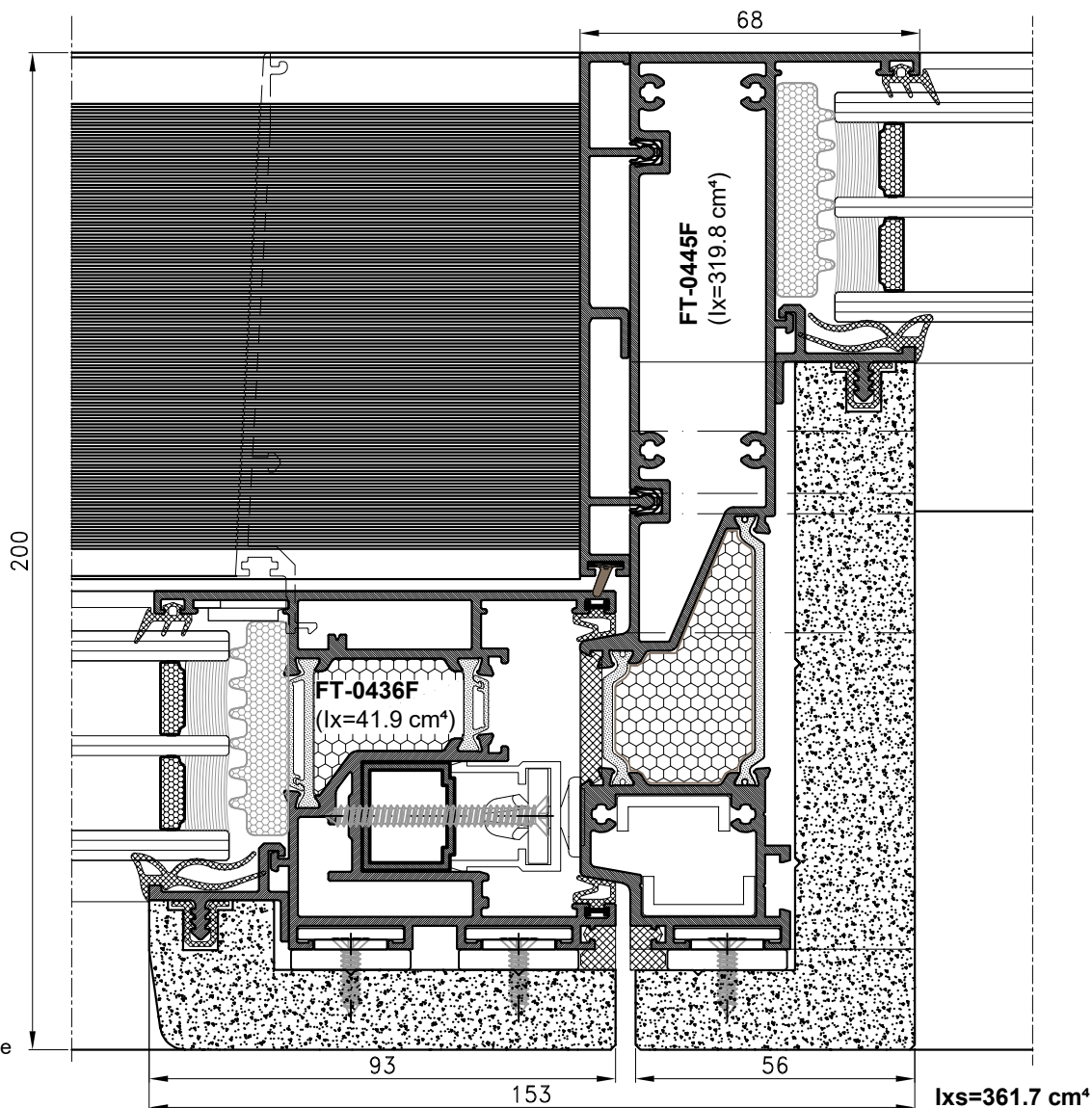

Max. omjer visine i širine krila
H:L ≤ 2.5

Max. sash height/width ratio
H:L ≤ 2.5

 Nije dopušteno
Not allowed

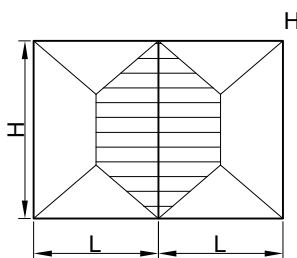

H= Visina krila
H= Sash height

L= Širina krila
L= Sash width

500 Pa ———

800 Pa ———

1200 Pa ———

2000 Pa ———

2400 Pa ———

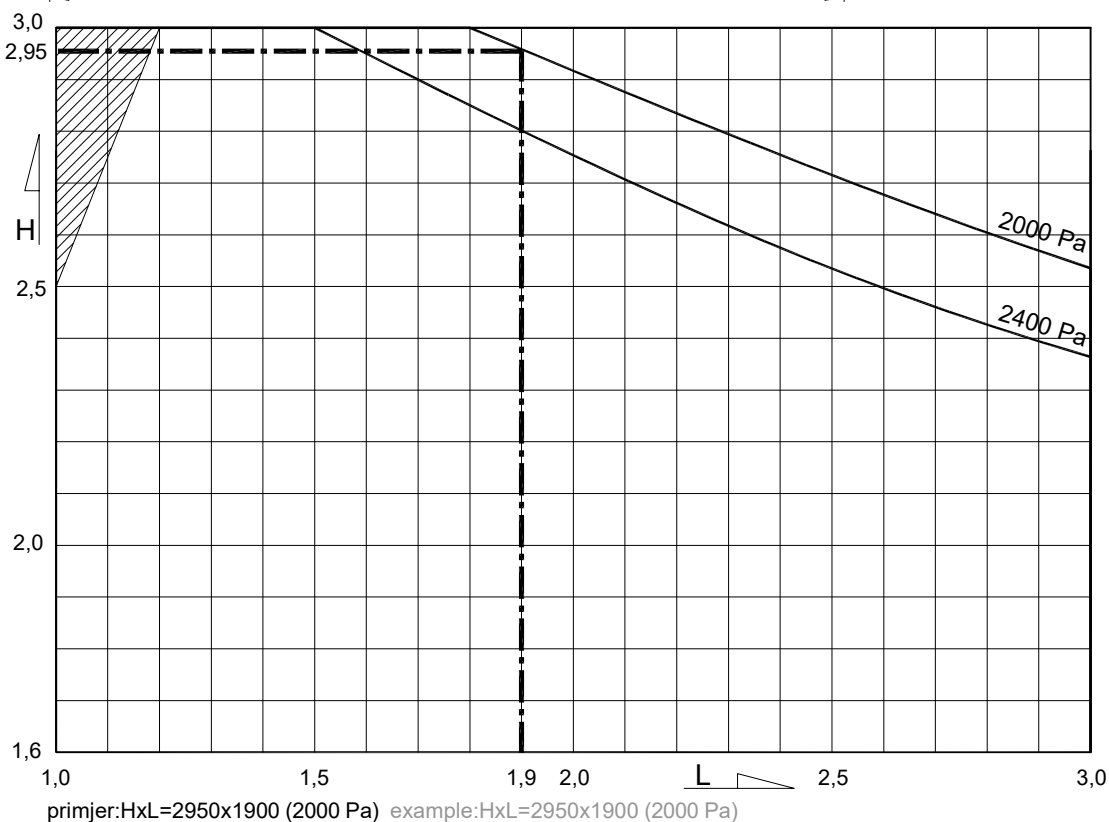

primjer: HxL=2950x1900 (2000 Pa) example: HxL=2950x1900 (2000 Pa)

Profili Profiles

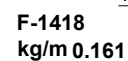
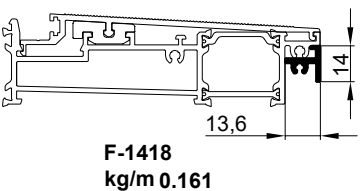
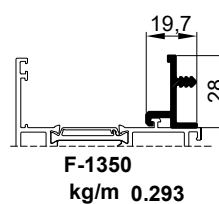
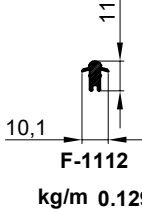
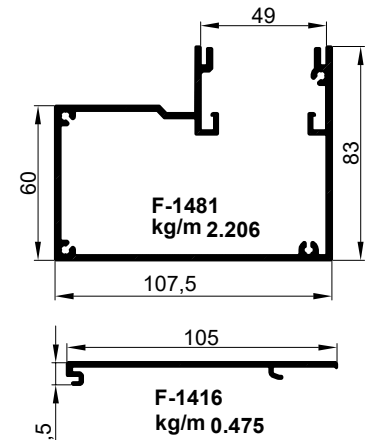
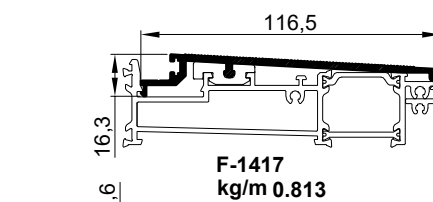
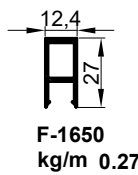
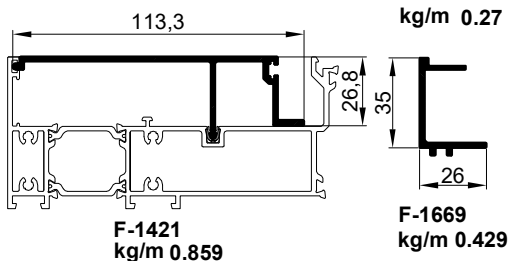
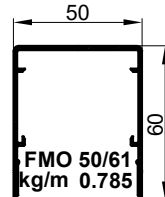
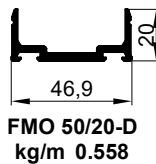
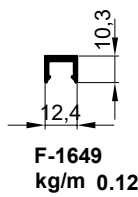
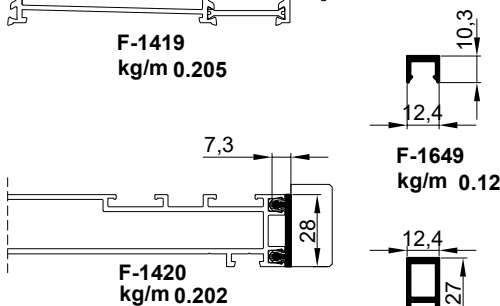
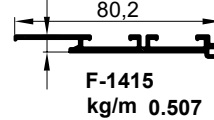
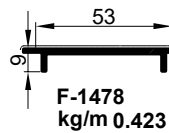
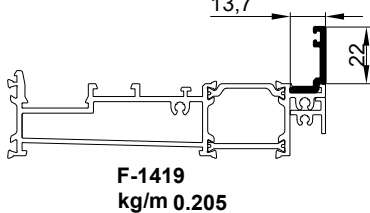
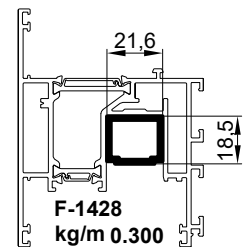
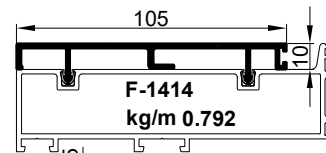
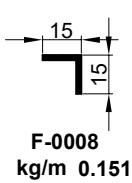
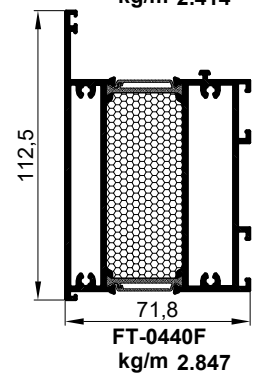
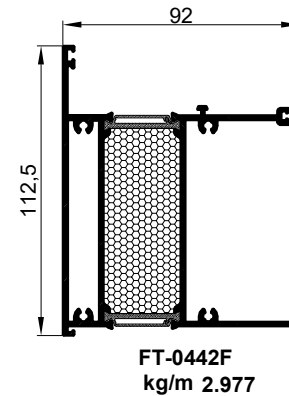
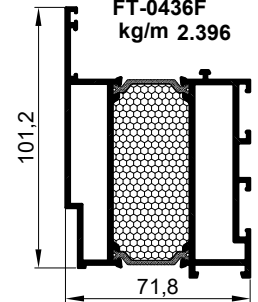
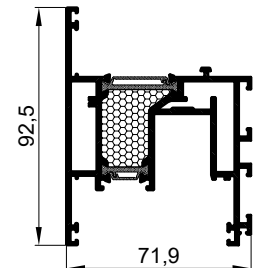
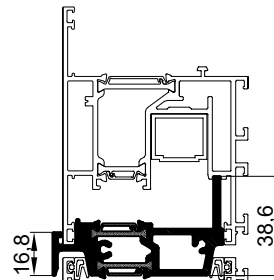
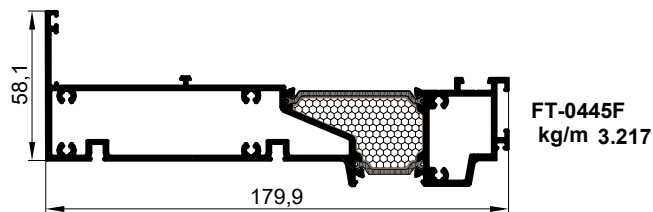
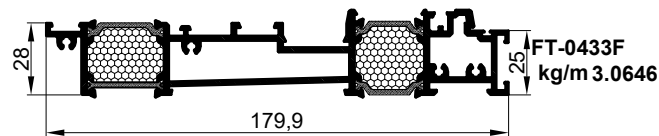
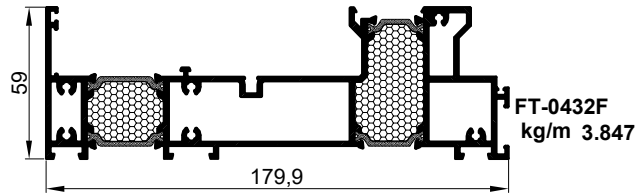
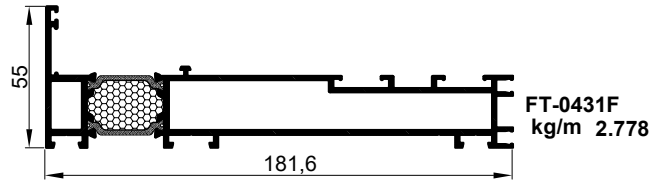
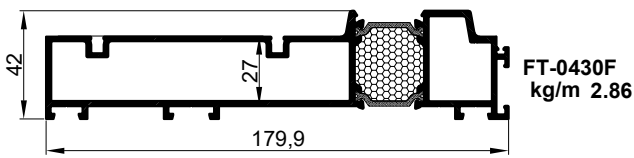

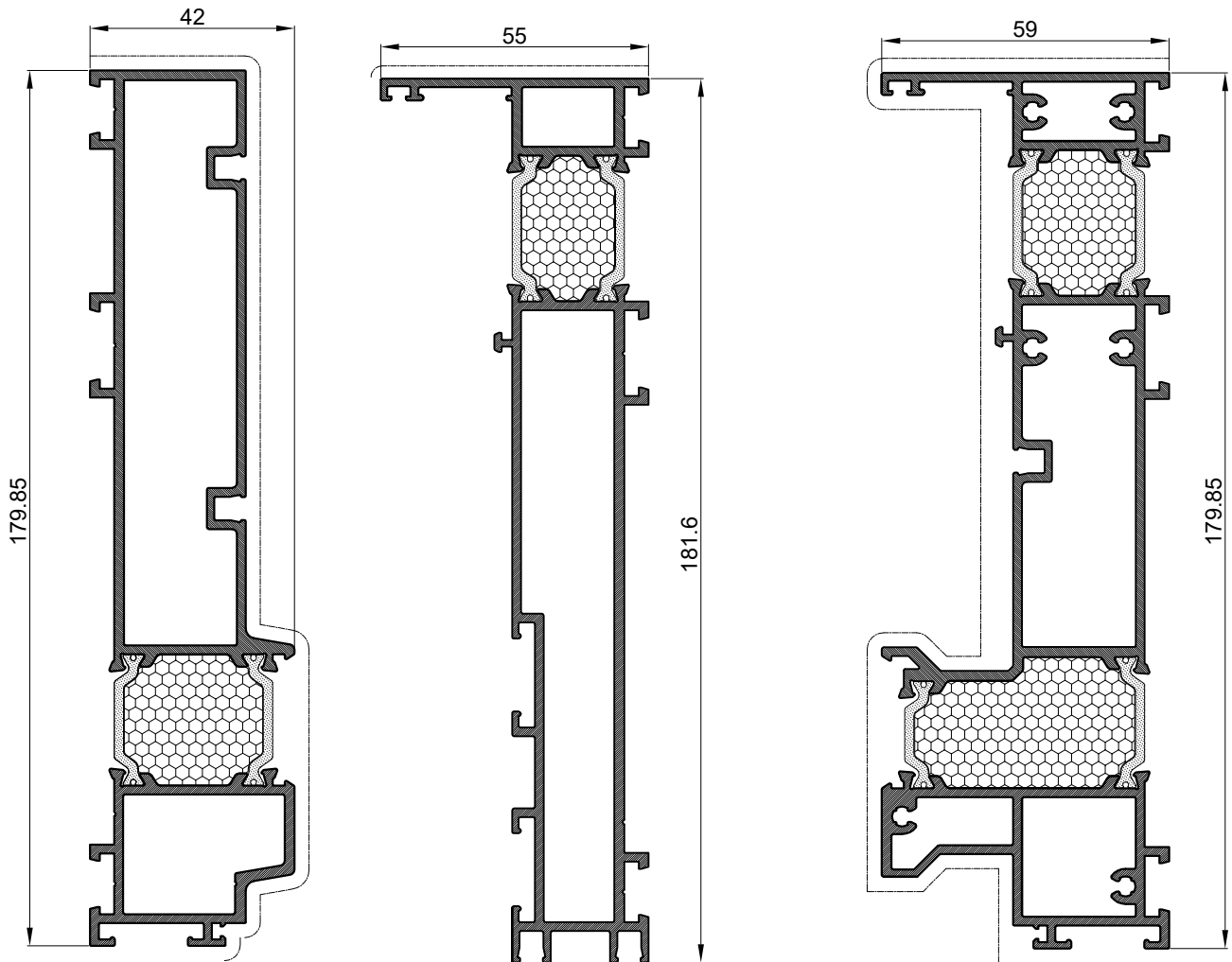

Profil rama Profile frame		
Art.Br. Art.Nr.	FT-0430F	
Težina Weight	kg/m	2.86
Opseg Perimeter	mm	576.71
Moment inercije Moment of inertia	I_x (cm ⁴)	16.45
	I_y (cm ⁴)	267.89
	W_x (cm ³)	7.13
	W_y (cm ³)	35.57
L	mm	6500

Profil rama Profile frame		
Art.Br. Art.Nr.	FT-0431F	
Težina Weight	kg/m	2.778
Opseg Perimeter	mm	662.73
Moment inercije Moment of inertia	I_x (cm ⁴)	13.06
	I_y (cm ⁴)	288.24
	W_x (cm ³)	3.41
	W_y (cm ³)	36.53
L	mm	6500

Profil rama Profile frame		
Art.Br. Art.Nr.	FT-0432F	
Težina Weight	kg/m	3.847
Opseg Perimeter	mm	700.13
Moment inercije Moment of inertia	I_x (cm ⁴)	37.31
	I_y (cm ⁴)	464.03
	W_x (cm ³)	10.81
	W_y (cm ³)	50.00
L	mm	6500

PROFIL BEZ XPS ISPUNE U NAZIVU NEMA NASTAVKA „F”
PROFILES WITHOUT XPS DO NOT HAVE ENDING "F"

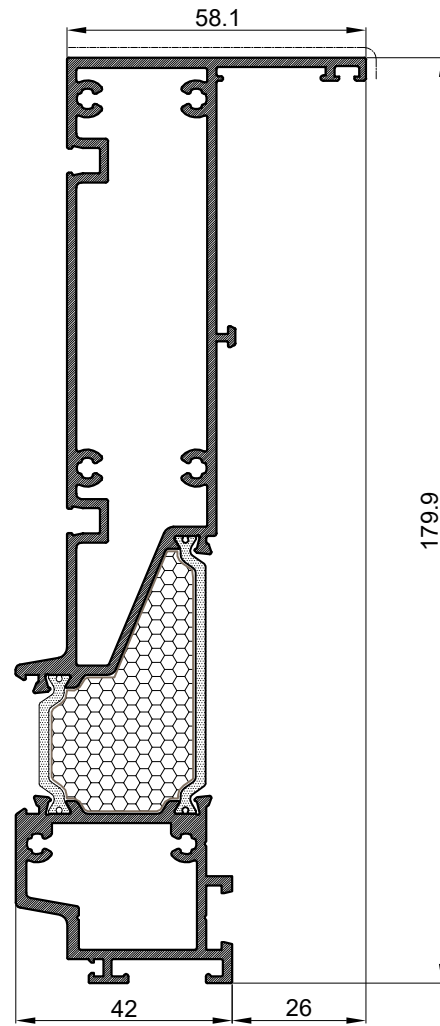
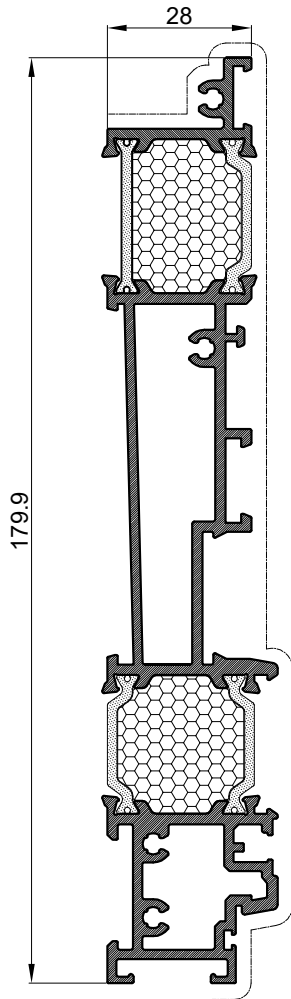

Profil rama Profile frame		
Art.Br. Art.Nr.	FT-0433F	
Težina Weight	kg/m	3.0646
Opseg Perimeter	mm	643.03
Moment inercije Moment of inertia	I_x (cm ⁴)	8.71
	I_y (cm ⁴)	230.71
	W_x (cm ³)	4.98
	W_y (cm ³)	28.61
L	mm	6500

Profil prečke Profile mullion		
Art.Br. Art.Nr.	FT-0445F	
Težina Weight	kg/m	3.217
Opseg Perimeter	mm	618.52
Moment inercije Moment of inertia	I_x (cm ⁴)	319.95
	I_y (cm ⁴)	23.95
	W_x (cm ³)	43.82
	W_y (cm ³)	5.41
	L	mm

PROFIL BEZ XPS ISPUNE U NAZIVU NEMA NASTAVKA „F”
PROFILES WITHOUT XPS DO NOT HAVE ENDING "F"

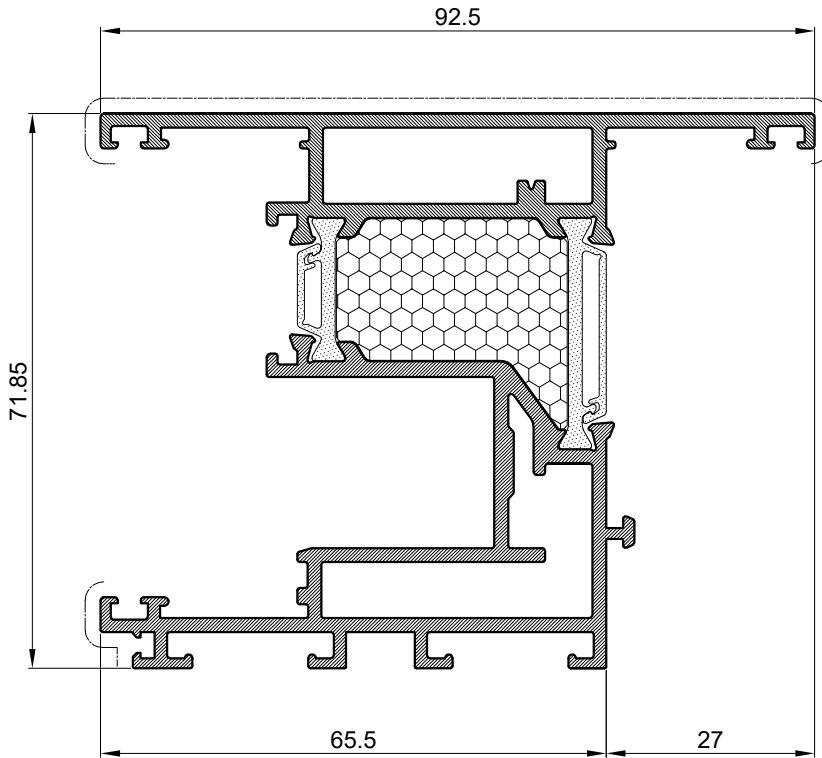

Profil krila Profile sash		
Art.Br. Art.Nr.	FT-0436F	
Težina Weight	kg/m	2.396
Opseg Perimeter	mm	581.91
Moment inercije Moment of inertia	I_x (cm^4)	34.56
	I_y (cm^4)	41.90
	W_x (cm^3)	7.02
	W_y (cm^3)	14.71
L	mm	6500

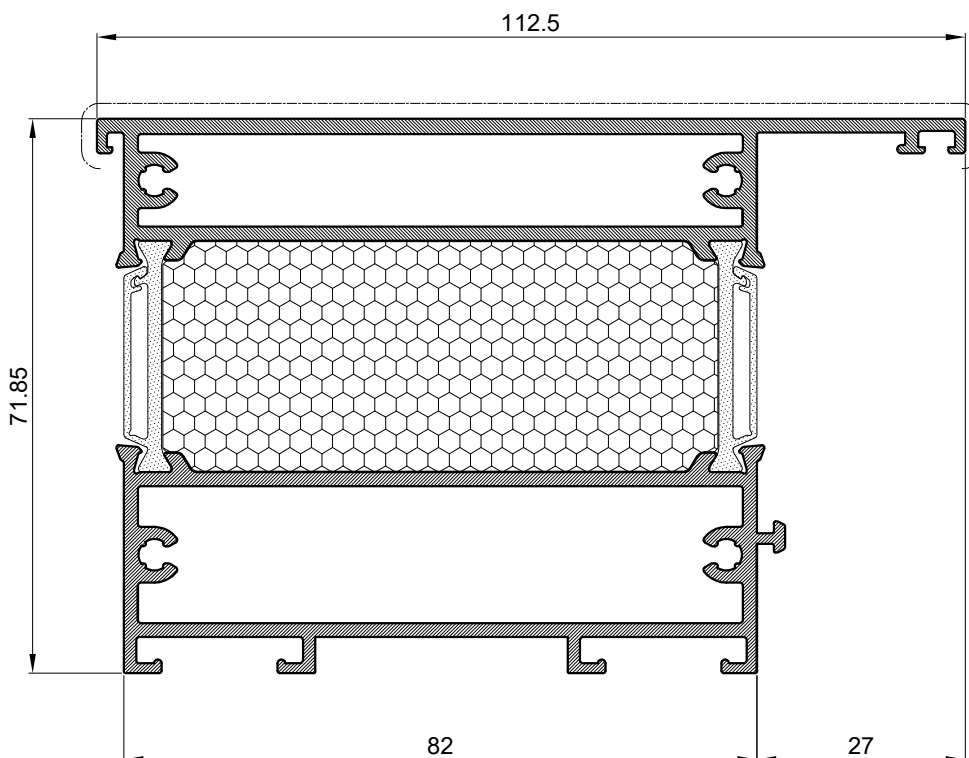

Profil prečke Profile mullion		
Art.Br. Art.Nr.	FT-0440F	
Težina Weight	kg/m	2.847
Opseg Perimeter	mm	445.73
Moment inercije Moment of inertia	I_x (cm^4)	94.34
	I_y (cm^4)	48.33
	W_x (cm^3)	14.57
	W_y (cm^3)	16.64
L	mm	6500

PROFIL BEZ XPS ISPUNE U NAZIVU NEMA NASTAVKA „F”
PROFILES WITHOUT XPS DO NOT HAVE ENDING „F”

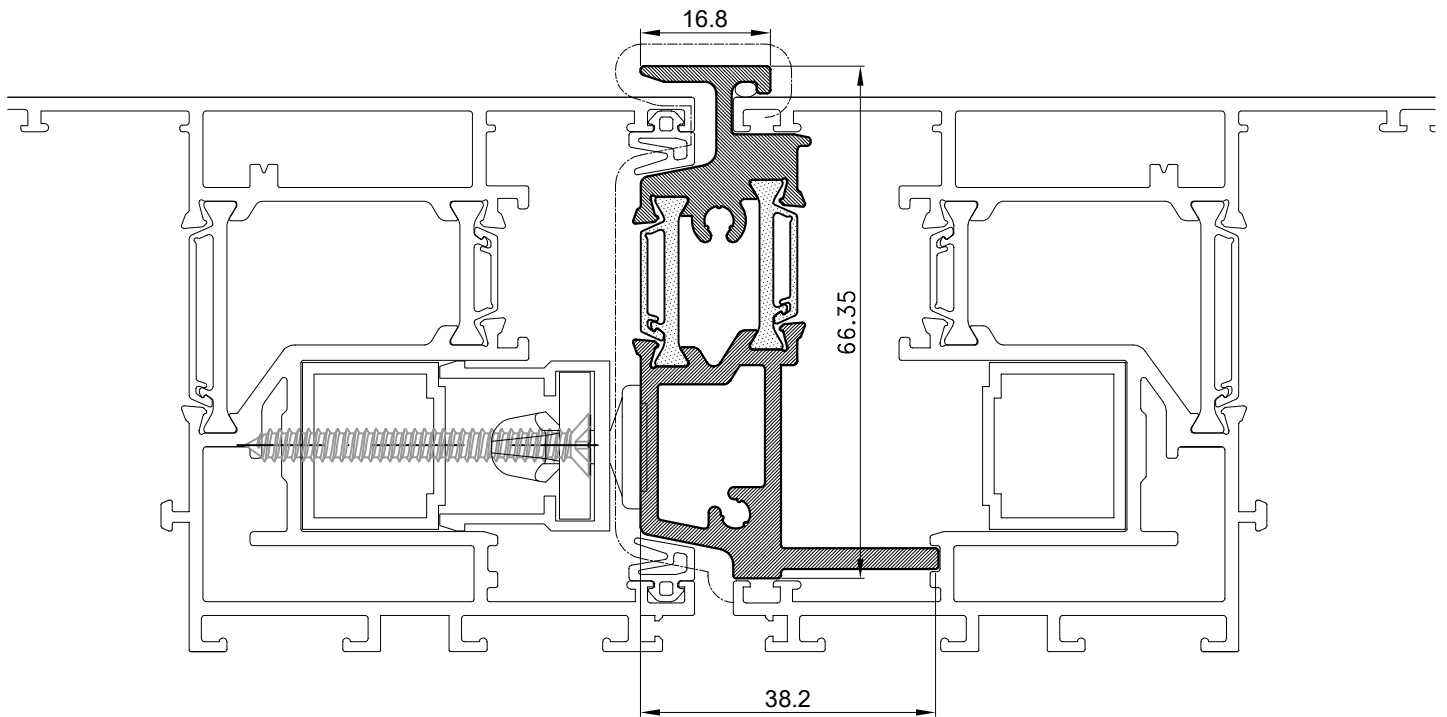

Spoj za četverokrilno Joint for four-sash		
Art.Br. Art.Nr.	FT-0441	
Težina Weight	kg/m	1.523
Opseg Perimeter	mm	581.91
Moment inercije Moment of inertia	I _x (cm ⁴)	3.31
	I _y (cm ⁴)	18.25
	W _x (cm ³)	1.28
	W _y (cm ³)	6.68
L	mm	6500

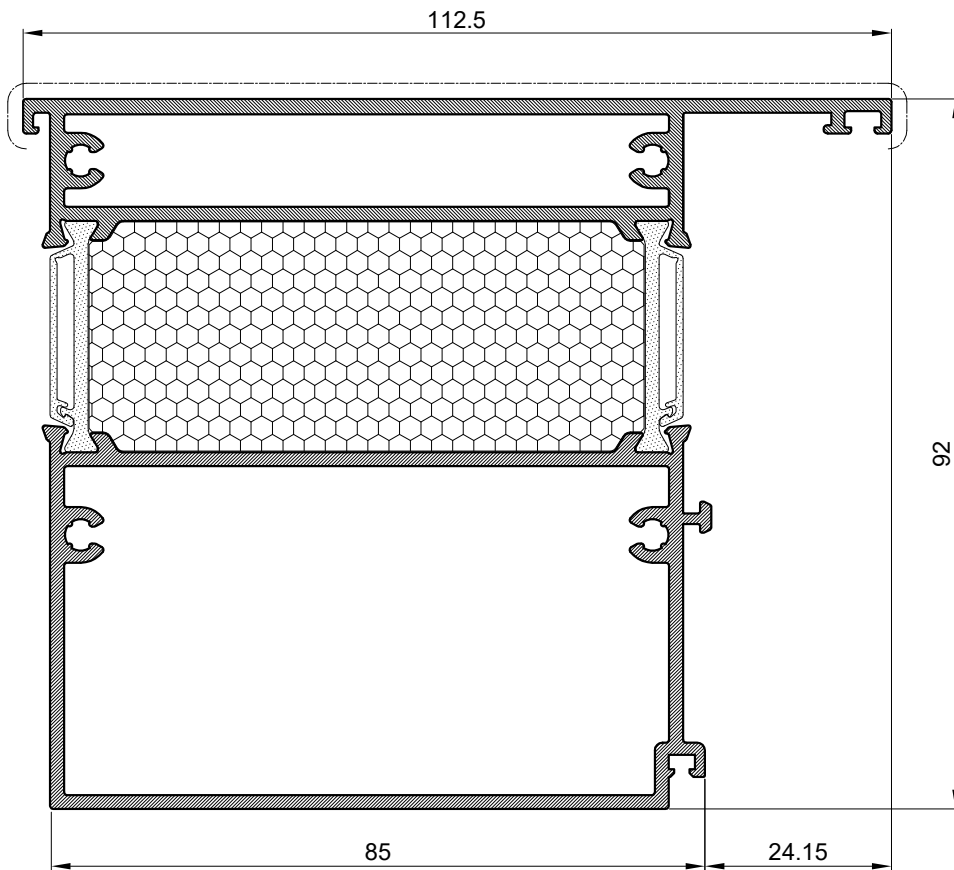

Profil prečke Profile mullion		
Art.Br. Art.Nr.	FT-0442F	
Težina Weight	kg/m	2.977
Opseg Perimeter	mm	495.11
Moment inercije Moment of inertia	I_x (cm ⁴)	105.56
	I_y (cm ⁴)	84.11
	W_x (cm ³)	16.36
	W_y (cm ³)	20.67
L	mm	6500

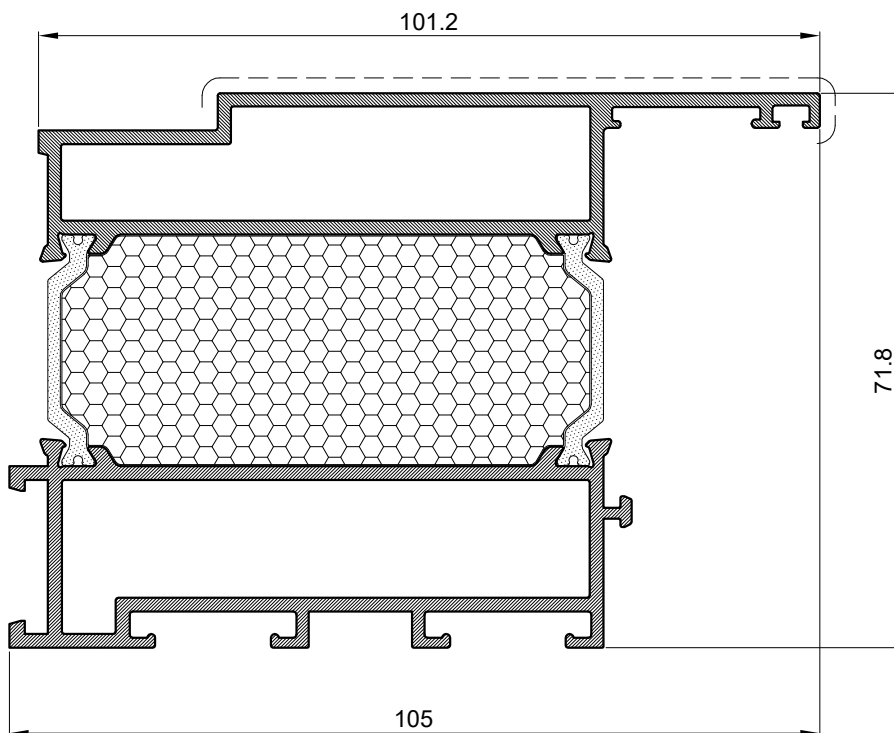

Profil umetka za fiksni dio Insert profile for fixed part		
Art.Br. Art.Nr.	FT-0446F	
Težina Weight	kg/m	2.414
Opseg Perimeter	mm	474.00
Moment inercije Moment of inertia	I_x (cm ⁴)	41.76
	I_y (cm ⁴)	64.81
	W_x (cm ³)	15.51
	W_y (cm ³)	10.63
L	mm	6500

PROFIL BEZ XPS ISPUNE U NAZIVU NEMA NASTAVKA „F”
PROFILES WITHOUT XPS DO NOT HAVE ENDING "F"

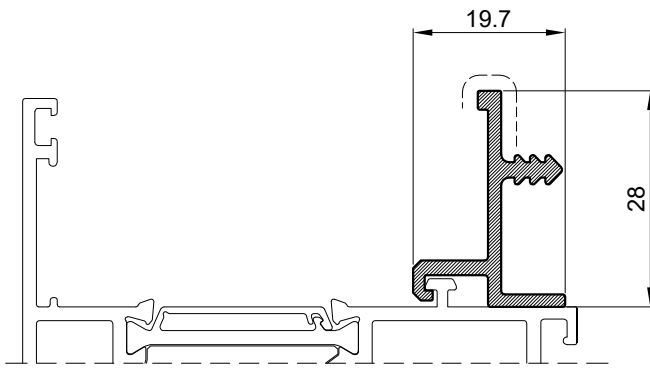

Staklo lajsna Glazing bead		
Art.-Br. Art.-Nr.	F-1350	
Težina Weight	kg/m	0.293
Opseg Perimeter	mm	124.90
L	mm	6500

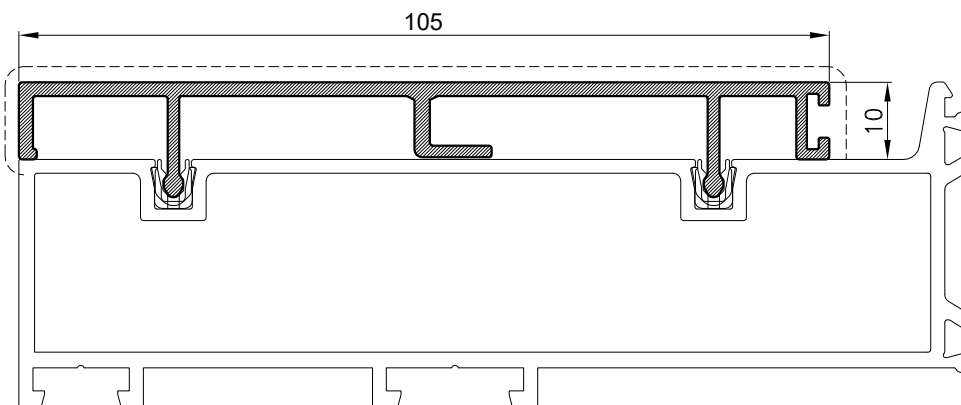

Profil Profile		
Art.-Br. Art.-Nr.	F-1414	
Težina Weight	kg/m	0.792
Opseg Perimeter	mm	339.05
L	mm	6500

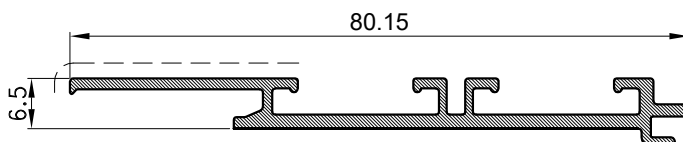

Profil Profile		
Art.-Br. Art.-Nr.	F-1415	
Težina Weight	kg/m	0.507
Opseg Perimeter	mm	348.15
L	mm	6500

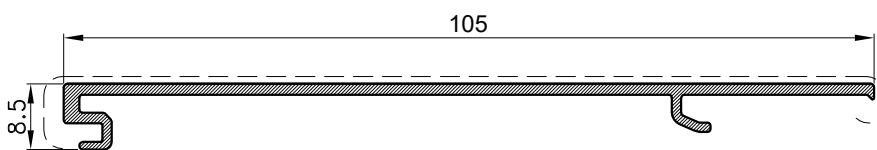

Profil Profile		
Art.-Br. Art.-Nr.	F-1416	
Težina Weight	kg/m	0.475
Opseg Perimeter	mm	462.32
L	mm	6500

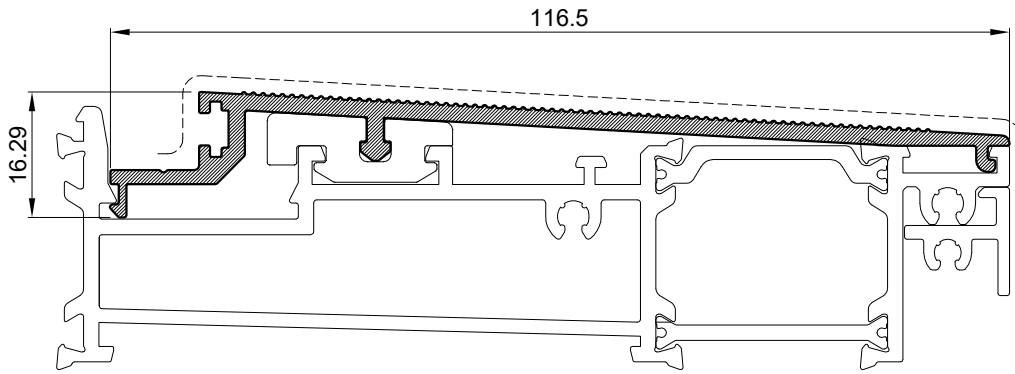

Profil Profile		
Art.-Br. Art.-Nr.	F-1417	
Težina Weight	kg/m	0.813
Opseg Perimeter	mm	319.92
L	mm	6500

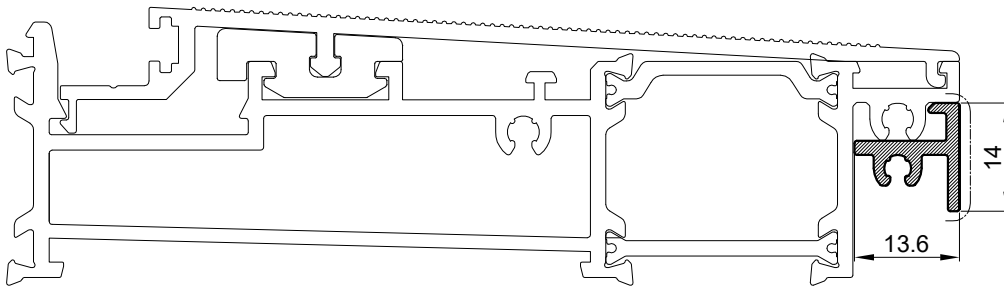

Profil Profile		
Art.-Br. Art.-Nr.	F-1418	
Težina Weight	kg/m	0.161
Opseg Perimeter	mm	73.66
L	mm	6500

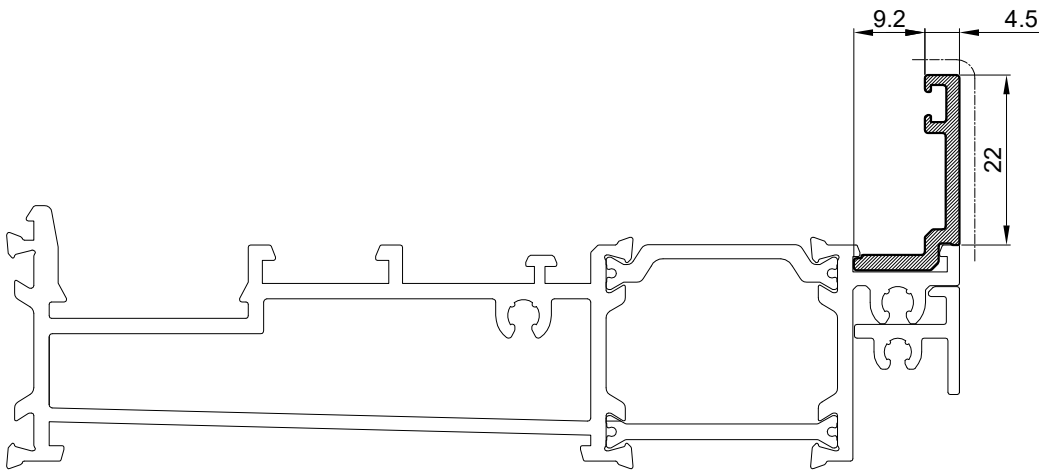

Profil Profile		
Art.-Br. Art.-Nr.	F-1419	
Težina Weight	kg/m	0.205
Opseg Perimeter	mm	89.12
L	mm	6500

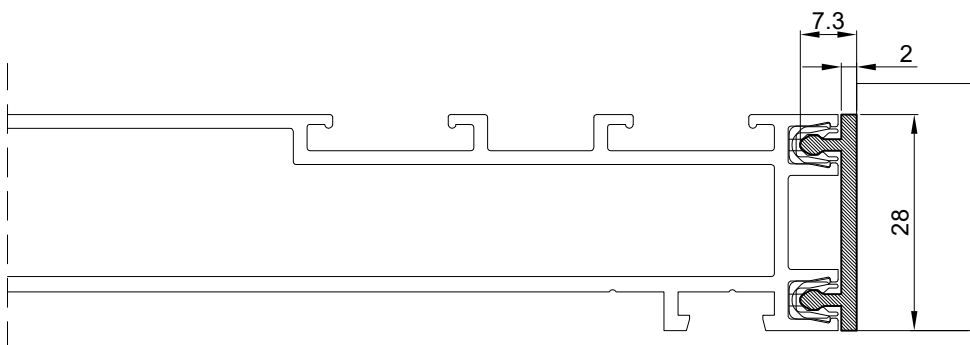

Profil Profile		
Art.-Br. Art.-Nr.	F-1420	
Težina Weight	kg/m	0.202
Opseg Perimeter	mm	81.15
L	mm	6500

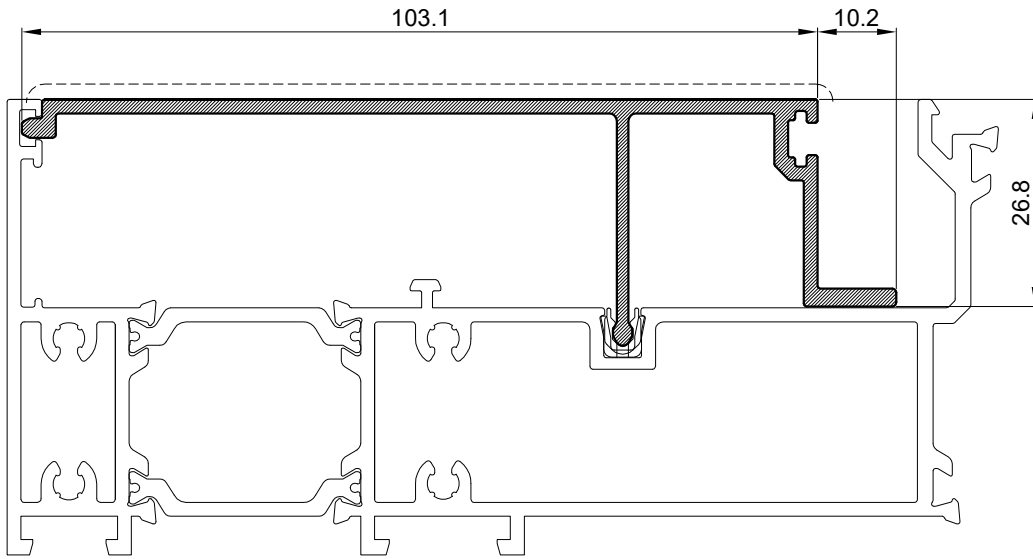

Profil Profile		
Art.-Br. Art.-Nr.	F-1421	
Težina Weight	kg/m	0.859
Opseg Perimeter	mm	553.90
L	mm	6500

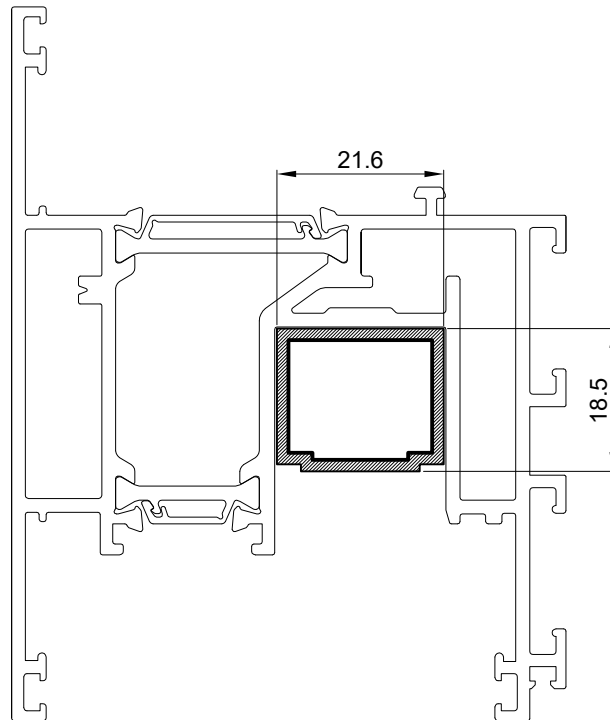

Profil Profile		
Art.-Br. Art.-Nr.	F-1428	
Težina Weight	kg/m	0.300
Opseg Perimeter	mm	80.19
L	mm	6500

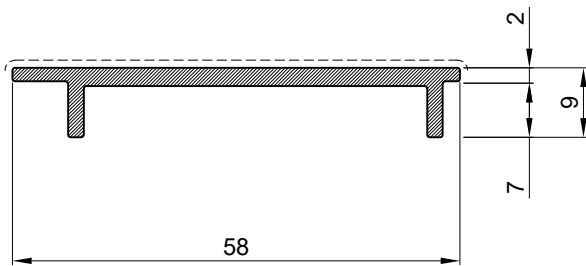

Profil Profile		
Art.-Br. Art.-Nr.	F-1478	
Težina Weight	kg/m	0.423
Opseg Perimeter	mm	145.78
L	mm	6500

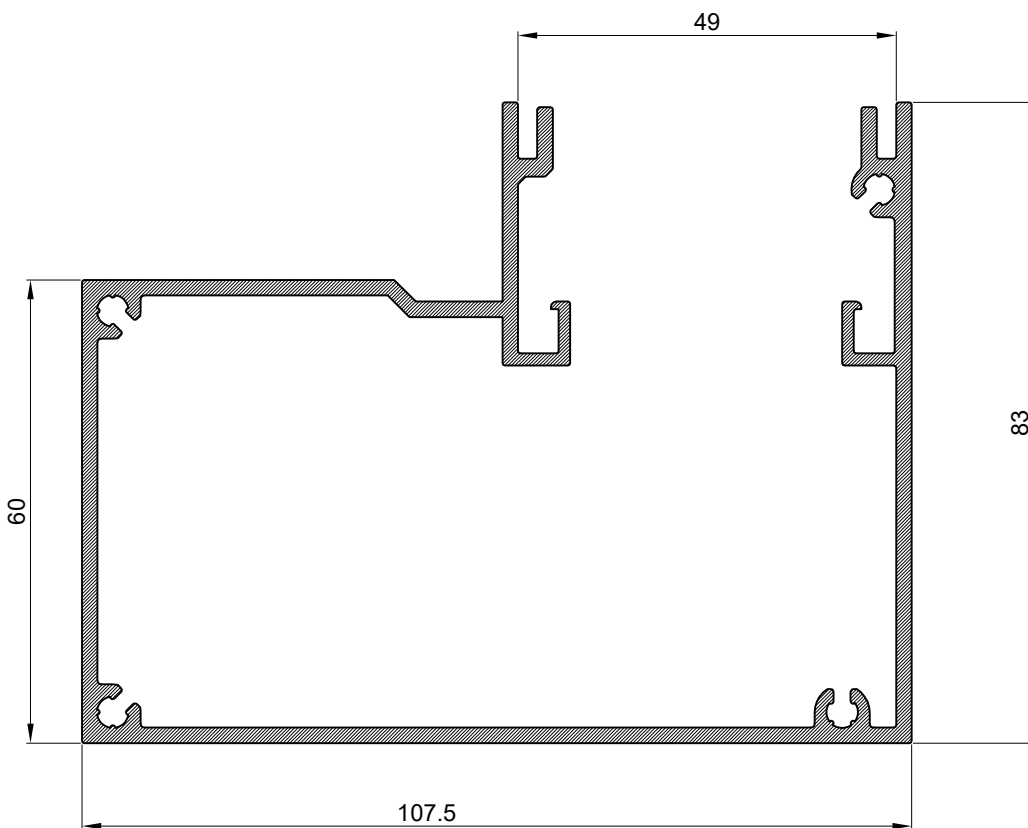

Profil Profile		
Art.-Br. Art.-Nr.	F-1481	
Težina Weight	kg/m	2.206
Opseg Perimeter	mm	819.40
L	mm	6500

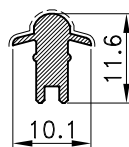

Al vodilica Al guide		
Art.-Br. Art.-Nr.	F-1112	
Težina Weight	kg/m	0.129
Opseg Perimeter	mm	45.43
L	mm	6500

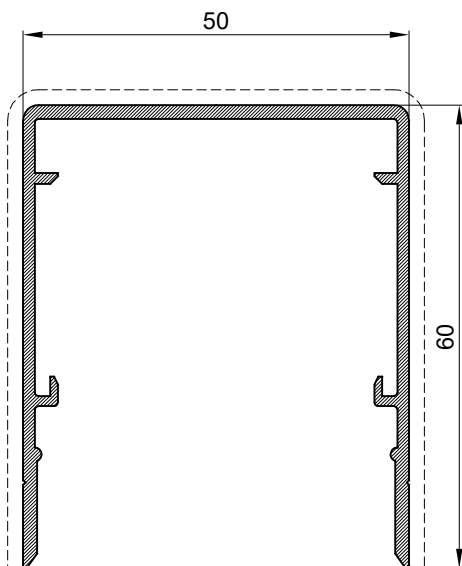
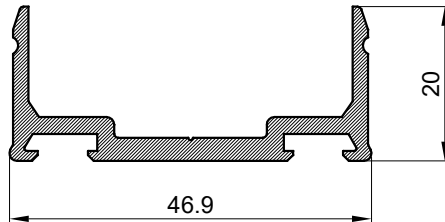
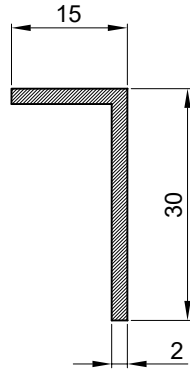
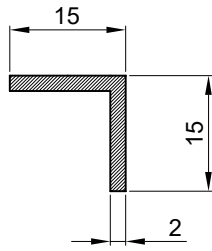

Profil Profile		
Art.-Br. Art.-Nr.	F-0008	
Težina Weight	kg/m	0.151
Opseg Perimeter	mm	60.00
L	mm	6500

Profil Profile		
Art.-Br. Art.-Nr.	F-0171	
Težina Weight	kg/m	0.232
Opseg Perimeter	mm	90.00
L	mm	6500

Profil Profile		
Art.-Br. Art.-Nr.	FMO 50/20-D	
Težina Weight	kg/m	0.558
Opseg Perimeter	mm	184.82
L	mm	6500

Profil Profile		
Art.-Br. Art.-Nr.	FMO 50/61	
Težina Weight	kg/m	0.785
Opseg Perimeter	mm	365.55
L	mm	6500

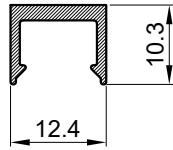

Profil Profile		
Art.-Br. Art.-Nr.	F-1649	
Težina Weight	kg/m	0.120
Opseg Perimeter	mm	62.37
L	mm	6500

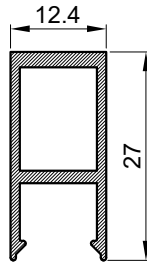

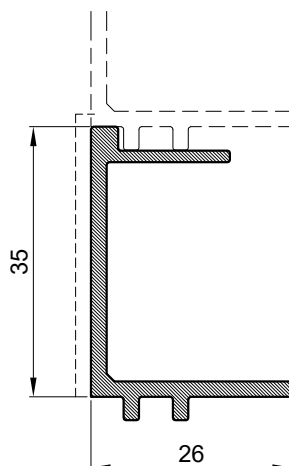

Profil Profile		
Art.-Br. Art.-Nr.	F-1650	
Težina Weight	kg/m	0.270
Opseg Perimeter	mm	99.51
L	mm	6500



Profil Profile		
Art.-Br. Art.-Nr.	F-1669	
Težina Weight	kg/m	0.421
Opseg Perimeter	mm	163.34
L	mm	6500

Vezni elementi

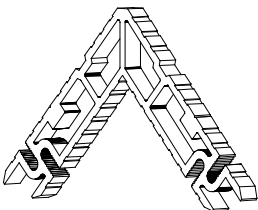
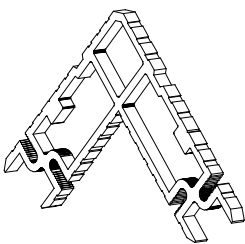
Connection elements

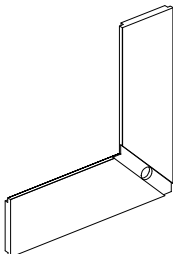
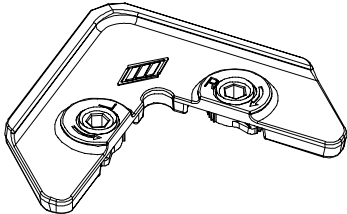
Oznaka Code	Izgled-presjek View-cross section	Opis Description	Materijal Material	Napomena Remark
710.193		<ul style="list-style-type: none"> - Kutna spojnica za komoru 25.2x9.9 - Corner bracket for chamber 25.2x9.9 	Al	
710.401		<ul style="list-style-type: none"> - Kutna spojnica za komoru 35.1x7.25 - Corner bracket for chamber 17.2x13 	Al	
730.002		<ul style="list-style-type: none"> - Kutna spojnica za komoru 2x4.8 - Corner bracket for chamber 24x8.4 	INOX	
730.017		<ul style="list-style-type: none"> - Kutnik u krilu za vanjsko spajanje (Termo 200 DA) - Corner bracket in sash for outside connection (Termo 200 DA) 	Zamak Zamak	
731.010		<ul style="list-style-type: none"> - Kutna spojnica za usku komoru - Monticelli - Corner bracket for tight chamber - Monticelli 	Zamak #3 Zamak #3	

PVC elementi
PVC elements

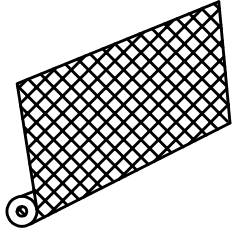
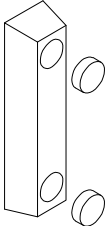
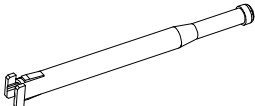
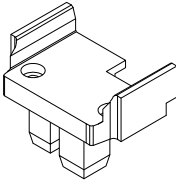
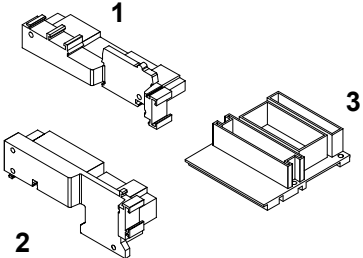
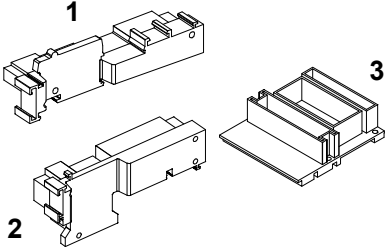
Oznaka Code	Izgled-presjek View-cross section	Opis Description	Materijal Material	Napomena Remark
340.047		- Mreža - Grid	PVC	
345.010		- Ublaživač udara krila (Termo 200 DA) - Sash hit bumper (Termo 200 DA)	EPDM	
360.009		- Sustav odvodnje kapljevina Monodrain - Drainage system Monodrain	Tvrda guma Hard rubber	
363.030		- Gumeni umetak za profil FT-0441 - Rubber insert for profile FT-0441	Tvrda guma Hard rubber	
365.058		- Set umetaka za lijeva vrata 1. 365.052 1 kom 2. 365.054 1 kom 3. 365.056 1 kom - Set of inserts for left door 1. 365.052 1 pcs 2. 365.054 1 pcs 3. 365.056 1 pcs	Tvrda guma Hard rubber	
365.059		- Set umetaka za desna vrata 1. 365.053 1 kom 2. 365.055 1 kom 3. 365.056 1 kom - Set of inserts for right door 1. 365.053 1 pcs 2. 365.055 1 pcs 3. 365.056 1 pcs	Tvrda guma Hard rubber	

Oznaka Code	Izgled-presjek View-cross section	Opis Description	Materijal Material	Napomena Remark
371.021		- Set čepova za masku na spoju krila i prečke (Termo 200 DA) 1. 371.020 2. 375.064 - Caps set for mask on sash and mullion joint (Termo 200 DA) 1. 371.020 2. 375.064	PVC	
374.083		- PVC umetak na spoju prečke i krila - PVC insert on mullion and sash joint	PVC	
374.063		- PVC umetak rama FT-0433 - PVC insert for frame FT-0433	Tvrda guma Hard rubber	
375.020		- Stara oznaka OK-120-01 - Former code OK120-01	PVC+EPDM PVC+EPDM	
375.048		- Umetak - Insert	PVC 30% st. vlakana PVC 30% gl. fibers	
375.050		- Kopča za spajanje drvenih obloga i al. profila Termo 200 DA - Clamp for connection of wooden coverings and al. profiles Termo 200 DA	PA6 30% st. vlakana PA6 30% gl. fibers	

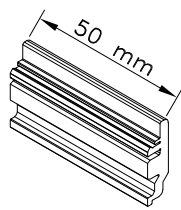
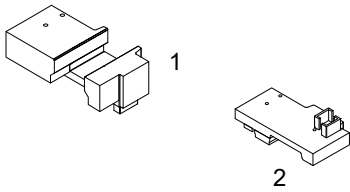
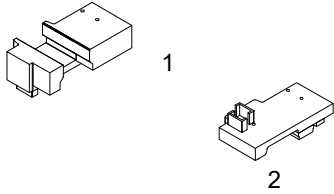
Oznaka Code	Izgled-presjek View-cross section	Opis Description	Materijal Material	Napomena Remark
373.078		-Usmjerivač krila -Minimalno četiri po krilu -Sash guide -Minimum of four per sash	PVC	
363.077		Set umetaka za lijeva trokrilna vrata (Termo 200 DA) 1. 363.071 kom.1 2. 363.073 kom.1 - Inserts set for left three-leaf doors (Termo 200 DA) 1. 363.071 pcs. 1 2. 363.073 pcs. 1	TPV	
363.078		Set umetaka za desna trokrilna vrata (Termo 200 DA) 1. 363.072 kom.1 2. 363.074 kom.1 - Inserts set for right three-leaf doors (Termo 200 DA) 1. 363.072 pcs. 1 2. 363.074 pcs. 1	TPV	

Mehanizmi Mechanisms

PODIZNO-KLIZNI MECHANIZAM ATRIUM Alu-HS 300 (HAUTAU)

- za krilo FT-0436F
- težina krila max. 300 kg
- mjere krila Fb x Fh = (720-3235) x (1200-2700)
- položaj ručke
 - vrata (Fh 2101-2400)..... 1004 mm

LIFT AND SLIDE MECHANISM ATRIUM Alu-HS 300 (HAUTAU)

- for sash FT-0436F
- sash weight max. 300 kg
- sash measurements Fb x Fh = (720-3235) x (1200-2700)
- handle position
 - door (Fh 2101-2400)..... 1004 mm

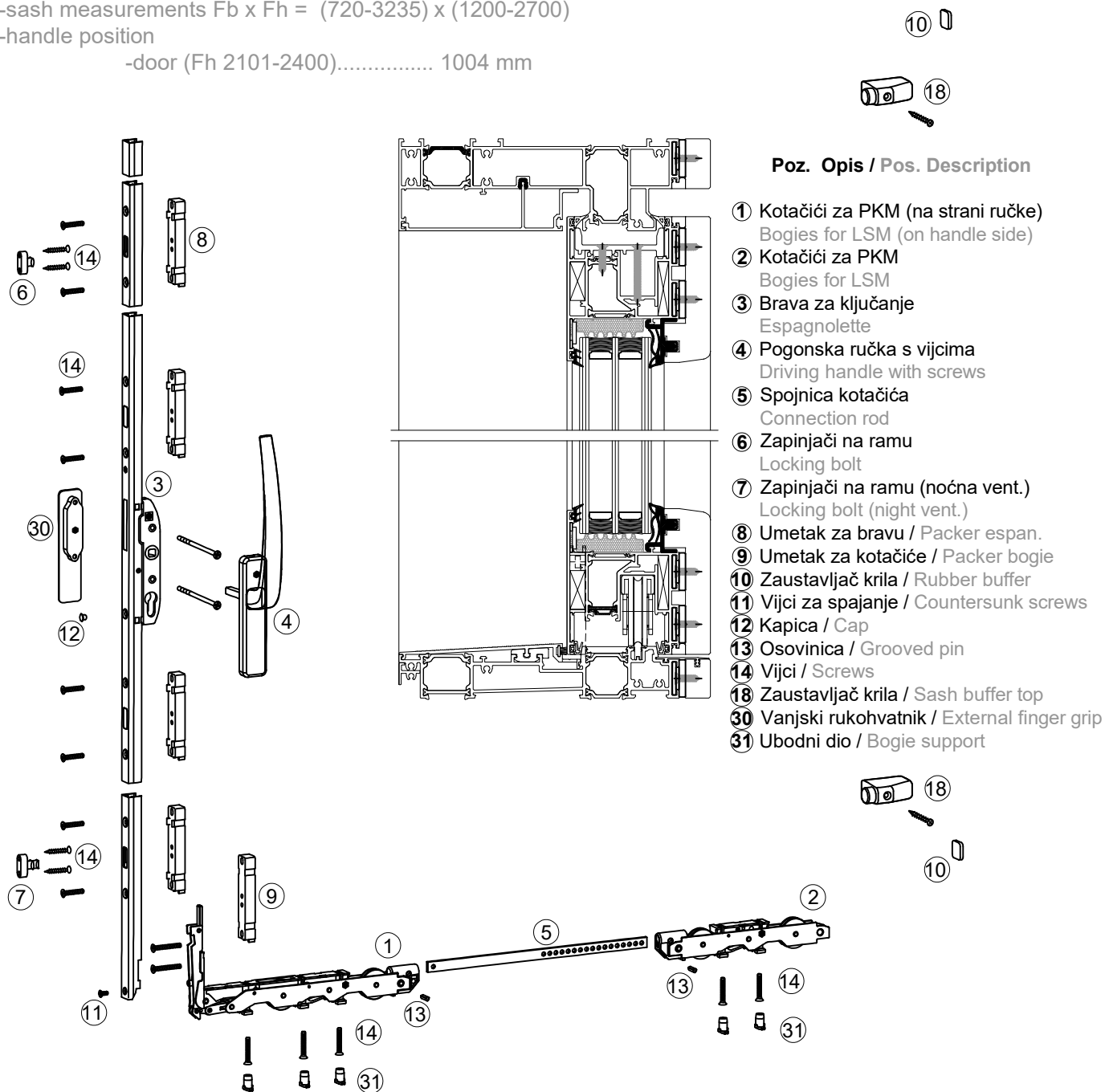

Poz. Opis / Pos. Description

- ① Kotačići za PKM (na strani ručke)
Bogies for LSM (on handle side)
- ② Kotačići za PKM
Bogies for LSM
- ③ Brava za ključanje
Espagnolette
- ④ Pogonska ručka s vijcima
Driving handle with screws
- ⑤ Spojnica kotačića
Connection rod
- ⑥ Zapinjači na ramu
Locking bolt
- ⑦ Zapinjači na ramu (noćna vent.)
Locking bolt (night vent.)
- ⑧ Umetak za bravu / Packer espan.
- ⑨ Umetak za kotačiće / Packer bogie
- ⑩ Zaustavljač krila / Rubber buffer
- ⑪ Vijci za spajanje / Countersunk screws
- ⑫ Kapica / Cap
- ⑬ Osovinica / Grooved pin
- ⑭ Vijci / Screws
- ⑮ Zaustavljač krila / Sash buffer top
- ⑯ Vanjski rukohvatnik / External finger grip
- ⑰ Ubodni dio / Bogie support

Montažne mjere za podizno-klizni mehanizam ATRIUM ALU-HS 300
 Montage measurements for lift and slide mechanism ATRIUM ALU-HS 300

TERMO 200 DA



Montaža prihvatnika na ramu
 Montage of frame acceptors

	A	B	C
Gr.180	-	600	1000
Gr.210	750	1200	1600
Gr.240	750	1200	1900
Gr.270	750	1200	2200

Obrada za pogonski mehanizam
 Processing for driving mechanism

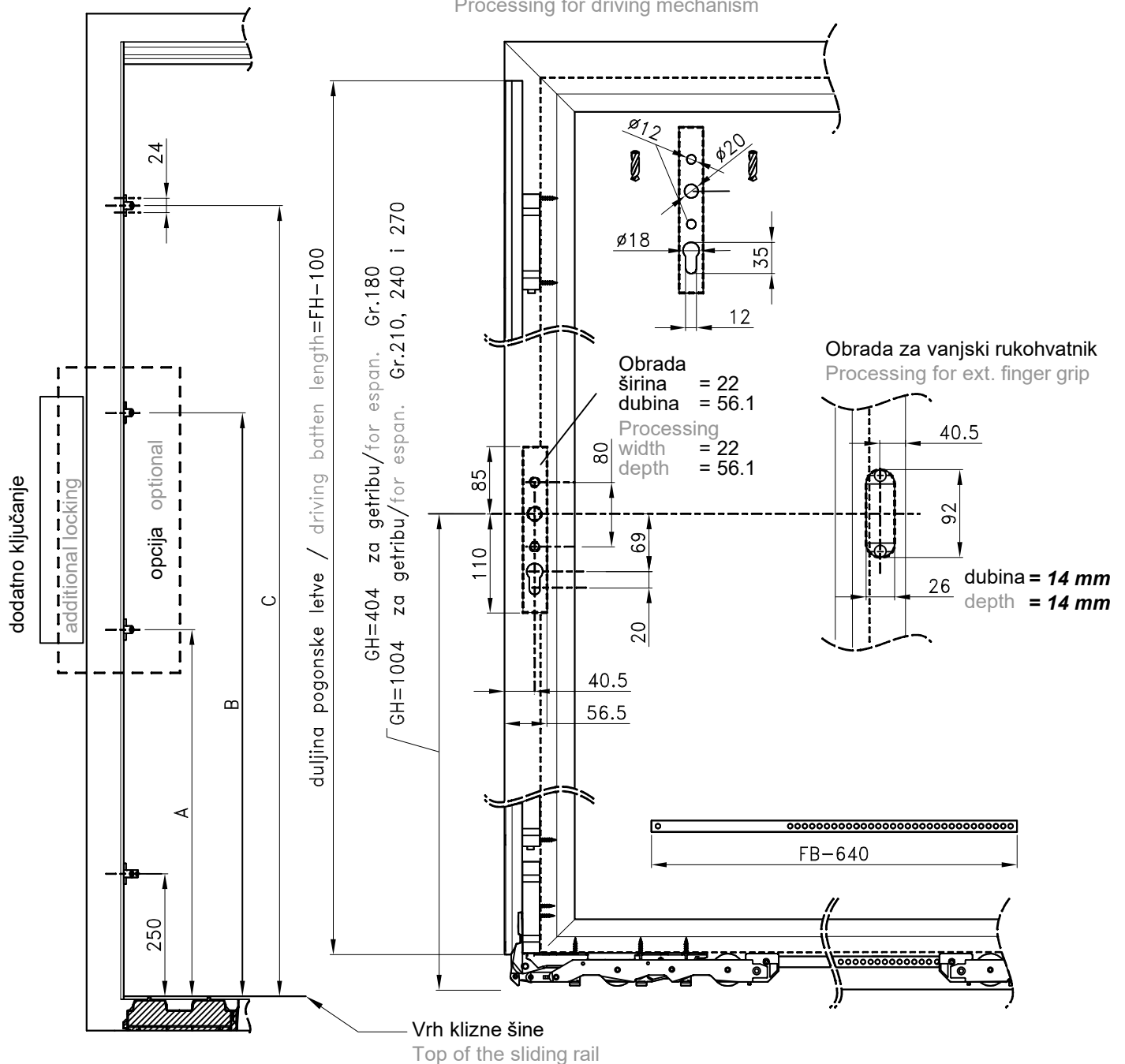

Montažne mjere za podizno-klizni mehanizam ATRIUM ALU-HS 300 Montage measurements for lift and slide mechanism ATRIUM ALU-HS 300

TERMO 200 DA



Montaža prihvatnika na ramu Montage of frame acceptors

	A	B	C
Gr.180	-	600	1000
Gr.210	750	1200	1600
Gr.240	750	1200	1900
Gr.270	750	1200	2200

① Kotačić/Bogies HS 300 (na strani ručke)/(handle side)

Kotači/Bogies HS 300 184575

② Kotačić/Bogies HS 300

Kotači/Bogies HS 300 184575

③ Brava za ključanje/Espagnolette

do/up to 300 kg

Brava s više ključanja/Multilock espag. Gr. 180
FH 1200 - 1800 mm 195419

Brava s više ključanja/Multilock espag. Gr. 210
FH 1801 - 2100 mm 195425

Brava s više ključanja/Multilock espag. Gr. 240
FH 2101 - 2400 mm 195431

Brava s više ključanja/Multilock espag. Gr. 270
FH 2401 - 2700 mm 195437

④ ③ Pogonska ručka s vijcima/Driving handle with screws

108.001.xx

01 Na upit/On request (RAL 9001)

03 Crna/Black 196859

04 Na upit/On request (Natural)

108.002.xx

01 Na upit/On request (RAL 9001)

03 Crna/Black 196871

04 Na upit/On request (Natural)

108.003.xx

01 RAL 9001 246212

03 Crna/Black 246272

04 Natural 246182

108.006.xx

01 RAL 9001 191554

03 Crna/Black 193015

04 Natural 204553

108.007.xx

01 RAL 9001 191557

03 Crna/Black 193618

04 Natural 204556

⑤ Spojnica za kotačiće/Connection rod

do/up to 300 kg

Spojnica za kotačiće/Connection rod Gr. 150
FB 720 - 1500 mm 184578

Spojnica za kotačiće/Connection rod Gr. 200
FB 1501 - 2000 mm 184581

Spojnica za kotačiće/Connection rod Gr. 250
FB 2001 - 2500 mm 184584

Spojnica za kotačiće/Connection rod Gr. 323
FH 2501 - 3235 mm 184587

⑥ Zapinjači na ramu/Locking bolt

Zapinjači na ramu/Locking bolt 184803

⑦ Zapinjač na ramu noćna vent.

Locking bolt for night vent.

Zapinjač na ramu noćna vent. 184749

Locking bolt for night vent.

⑧ ⑨ Umetak za bravu/ Packer

Umetak za bravu/Packer 188633

⑩ ⑪ ⑫

⑬ ⑳ Dodaci za/Accessories for Alu-HS 300

Dodaci za/Accessories for Alu-HS 300 188636

⑭ Vijci/Screws





Vijci/Screws 204319

⑮ Zaustavljač krila/Sash buffer

Zaustavljač krila/Sash buffer bijeli/white 187480



Zaustavljač krila/Sash buffer crni/black 187477

Zaustavljač krila/Sash buffer sivi/grey 239855

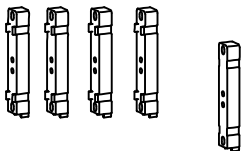
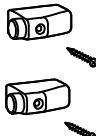
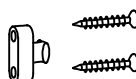
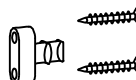
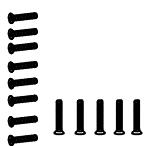
Oznaka Code	Izgled-presjek View-cross section	Opis Description	Materijal Material	Napomena Remark
149.001		<ul style="list-style-type: none"> -Kotačići za podizno klizni mehanizam ATRIUM Alu-HS 300 (300 kg) -Oznaka proizvođača 184575 -Za krilo FT-0436F i vodilicu F-1112 - Bogies for Lift and slide mechanism ATRIUM Alu-HS 300 (300 kg) -Manufacturer code 184575 -For sash FT-0436F and guide F-1112 	-	
		Hautau		
149.002		<ul style="list-style-type: none"> -Set dijelova mehanizma ATRIUM Alu-HS 300 -Oznaka proizvođača 188636 -Set of parts ATRIUM Alu-HS 300 -Manufacturer code 188636 	-	
		Hautau		
149.007		<ul style="list-style-type: none"> - Brava za ključanje HS 200 vel. 180 - Oznaka proizvođača 195419 (Fh 1200-1800) - Espagnolette HS 200 size180 - Manufacturer code 195419 (Fh 1200-1800) 	-	
149.008		<ul style="list-style-type: none"> - Brava za ključanje HS 200 vel. 210 - Oznaka proizvođača 195425 (Fh 1801-2100) - Espagnolette HS 200 size 210 - Manufacturer code 195425 (Fh 1801-2100) 		
149.009		<ul style="list-style-type: none"> - Brava za ključanje HS 200 vel. 240 - Oznaka proizvođača 195431 (Fh 2101-2400) - Espagnolette HS 200 size 240 - Manufacturer code 195431 (Fh 2101-2400) 		
149.010		<ul style="list-style-type: none"> - Brava za ključanje HS 200 vel. 270 - Oznaka proizvođača 195437 (Fh 2401-2700) - Espagnolette HS 200 size 270 - Manufacturer code 195437 (Fh 2401-2700) 		
		Hautau		
149.011		<ul style="list-style-type: none"> - Spojnica kotačića Gr. 150 - Oznaka proizvođača 184578 (Fb 720-1500) - Connecting rod Gr. 150 - Manufacturer code 184578 (Fb 720-1500) 	-	
149.012		<ul style="list-style-type: none"> - Spojnica kotačića Gr. 200 - Oznaka proizvođača 184581 (Fb 1501-2000) - Connecting rod Gr. 200 - Manufacturer code 184581 (Fb 1501-2000) 		
149.013		<ul style="list-style-type: none"> - Spojnica kotačića Gr. 250 - Oznaka proizvođača 184584 (Fb 2001-2500) - Connecting rod Gr. 250 - Manufacturer code 184584 (Fb 2001-2500) 		
149.014		<ul style="list-style-type: none"> - Spojnica kotačića Gr. 323 - Oznaka proizvođača 184587 (Fb 2501-3235) - Connecting rod Gr. 323 - Manufacturer code 184587 (Fb 2501-3235) 		
		Hautau		

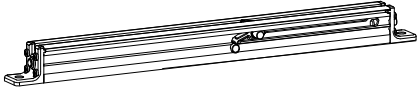
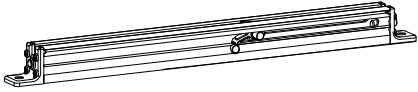
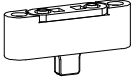
Oznaka Code	Izgled-presjek View-cross section	Opis Description	Materijal Material	Napomena Remark
149.029		<ul style="list-style-type: none"> - Umetci za bravu i kotačiće - Oznaka proizvođača 188633 - Packers for espag. and bogies - Manufacturer code 188633 	-	
		Hautau		
149.024		<ul style="list-style-type: none"> - Zaustavljač krila set - Oznaka proizvođača..... 187480-bijeli 187477-crni 239855-sivi - Sash buffer set - Manufacturer code..... 187480-white 187477-black 239855-gray 	-	
		Hautau		
149.028		<ul style="list-style-type: none"> - Zapinjač na ramu - Oznaka proizvođača 184803 - Striker - Manufacturer code 184803 	-	
		Hautau		
149.026		<ul style="list-style-type: none"> - Zapinjač na ramu (noćna ventilacija) - Oznaka proizvođača 184749 - Striker (night vent) - Manufacturer code 184749 	-	
		Hautau		
149.027		<ul style="list-style-type: none"> - Set vijaka - Oznaka proizvođača 198105 - Screw set - Manufacturer code 198105 	-	
		Hautau		

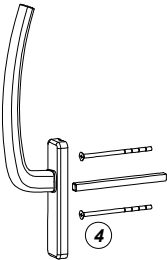
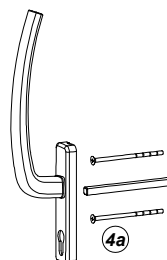
Oznaka Code	Izgled-presjek View-cross section	Opis Description	Materijal Material	Napomena Remark
149.030		<ul style="list-style-type: none"> - Usporivač krila za težine krila ≤ 200 kg - Atrium comfort close -HAUTAU - Sash retarder for sash weight ≤ 200 kg - Atrium comfort close -HAUTAU 	-	
		Hautau		
149.031		<ul style="list-style-type: none"> - Usporivač krila za težine krila > 200....300 kg - Atrium comfort close -HAUTAU - Sash retarder for sash weight > 200....300 kg - Atrium comfort close -HAUTAU) 	-	
		Hautau		
149.032		<ul style="list-style-type: none"> - Usporivač krila-dodatak na ramu - Atrium comfort close -HAUTAU - Sash retarder - addition on frame - Atrium comfort close -HAUTAU 	-	
		Hautau		

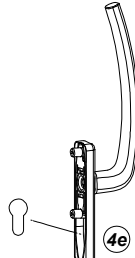
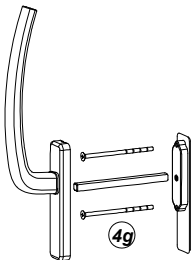

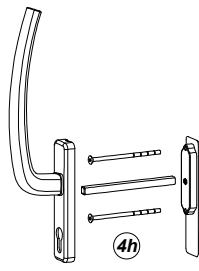
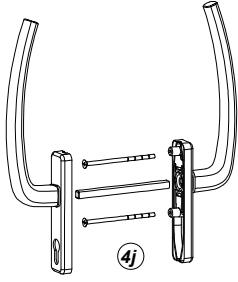
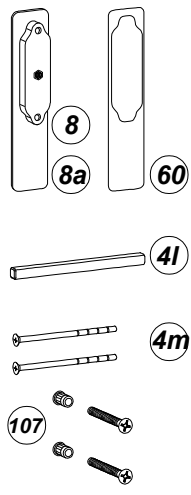

Oznaka Code	Izgled-presjek View-cross section	Opis Description	Materijal Material	Napomena Remark
108.001.01 03 04		<ul style="list-style-type: none"> - Unutarnja ručka (bez vanjskog prihvatnika) - Oznaka proizvođača na upit (RAL 9001) 196859 (crna) na upit (natural) - Interior handle (without exterior finger grip) - Manufacturer code on req. (RAL 9001) 196859 (black) on req. (natural) 	-	
108.002.01 03 04		<ul style="list-style-type: none"> - Unutarnja ručka sa cilindrom za ključanje (bez vanjskog prihvatnika) - Oznaka proizvođača na upit (RAL 9001) 196871 (crna) na upit (natural) - Interior handle with locking cylinder (without exterior finger grip) - Manufacturer code on req. (RAL 9001) 196871 (black) on req. (natural) 	-	
108.003.01 03 04		<ul style="list-style-type: none"> - Unutarnja ručka (bez vanjskog prihvatnika i osovine) - Oznaka proizvođača 246212 (RAL 9001) 246272 (crna) 246182 (natural) - Interior handle (without exterior finger grip and axle) - Manufacturer code 246212 (RAL 9001) 246272 (black) 246182 (natural) 	-	
108.004.01 03 04		<ul style="list-style-type: none"> - Unutarnja ručka sa cilindrom za ključanje (bez vanjskog prihvatnika i osovine) - Oznaka proizvođača 246215 (RAL 9001) 246275 (crna) 246185 (natural) - Interior handle with locking cylinder (without exterior finger grip and axle) - Manufacturer code 246215 (RAL 9001) 246275 (black) 246185 (natural) 	-	
108.005.01 03 04		<ul style="list-style-type: none"> - Vanjska ručka sa cilindrom za ključanje (bez osovine) - Oznaka proizvođača 246218 (RAL 9001) 246278 (crna) 246188 (natural) - Exterior handle with locking cylinder (without axle) - Manufacturer code 246218 (RAL 9001) 246278 (black) 246188 (natural) 	-	
180.006.01 03 04		<ul style="list-style-type: none"> - Unutarnja ručka -set - Oznaka proizvođača 191554 (RAL 9001) 193615 (crna) 204553 (natural) - Interior handle -set - Manufacturer code 191554 (RAL 9001) 193615 (black) 204553 (natural) 	-	

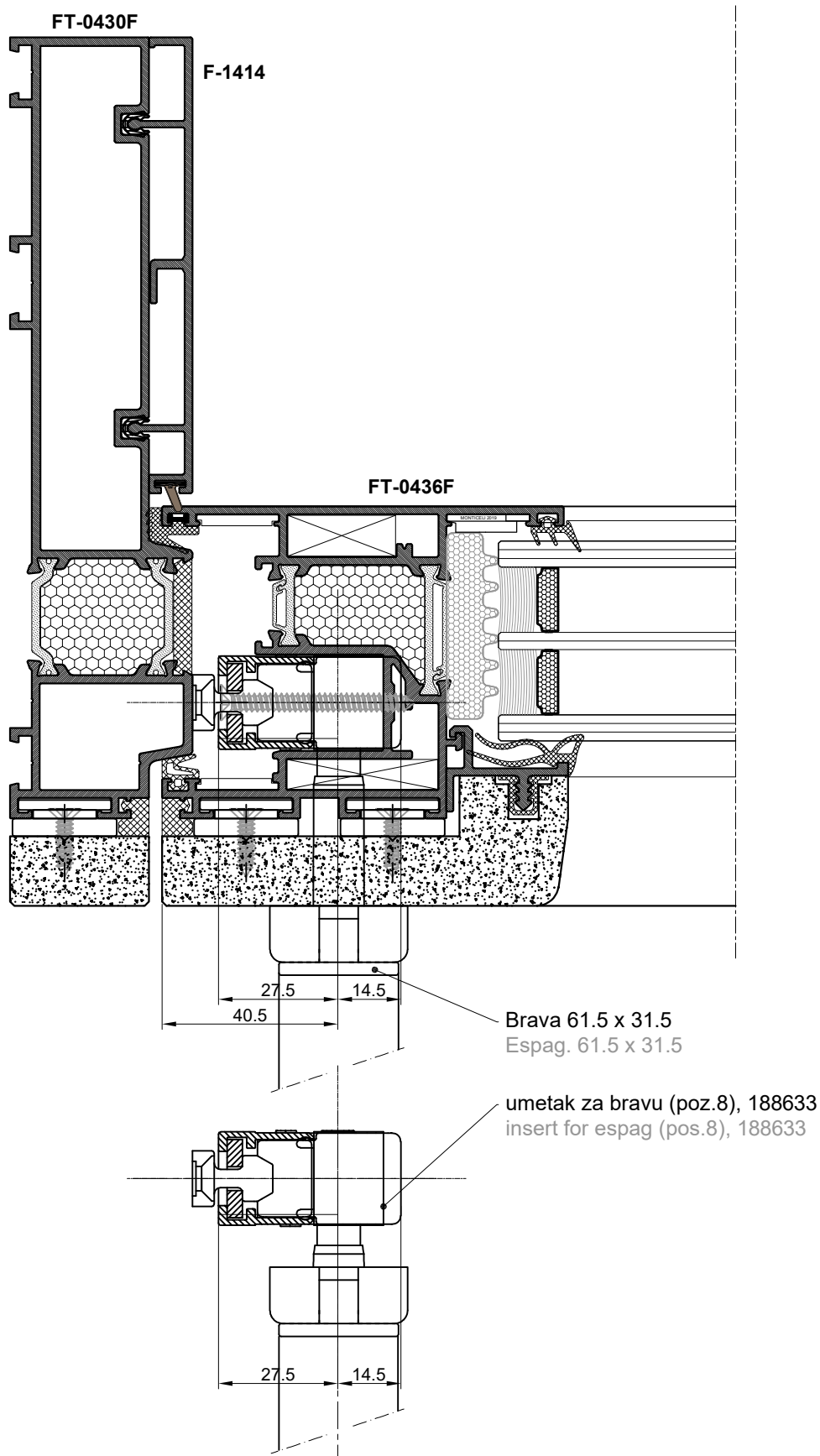
Oznaka Code	Izgled-presjek View-cross section	Opis Description	Materijal Material	Napomena Remark
108.007.01 03 04		<ul style="list-style-type: none"> - Unutarnja ručka-set (sa cilindrom za ključanje) - Oznaka proizvođača 191557 (RAL 9001) 193618 (crna) 204556 (natural) - Interior handle-set (with locking cylinder) - Manufacturer code 191557 (RAL 9001) 193618 (black) 204556 (natural) <p>Hautau</p>	-	
108.008.01 03 04		<ul style="list-style-type: none"> - Pogonske ručke-set (sa cilindrom za ključanje) - Oznaka proizvođača 191563 (RAL 9001) 193621 (crna) 206863 (natural) - Driving handles-set (with lockig cylinder) - Manufacturer code 191563 (RAL 9001) 193621 (black) 206863 (natural) <p>Hautau</p>	-	
108.009.01 03 04		<ul style="list-style-type: none"> -Standardni vanjski rukohvatnik 9.5 mm - Oznaka proizvođača 191527 (RAL 9001) 193600 (crna) 185158 (natural) -Standard exterior finger grip 9.5 mm - Manufacturer code 191527 (RAL 9001) 193600 (black) 185158 (natural) -Ravni vanjski rukohvatnik 6.5 mm -Oznaka proizvođača 217698 (RAL 9001) 217704 (crna) 217692 (natural) -Flat exterior finger grip 6.5 mm -Manufacturer code 217698 (RAL 9001) 217704 (black) 217692 (natural) -Brtva za vanjski rukohvatnik -Gasket for exterior finger grip -Osovina -Axle -Vijci M5x100 -Screws M5x100 -Zakivne matice sa vijkom -Rivet nuts with screw <p>Hautau</p>	-	

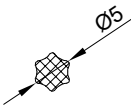

PODIZNO-KLIZNI MEHANIZAM ATRIUM Alu-HS 300 (HAUTAU)
LIFT AND SLIDE MECHANISM ATRIUM Alu-HS 300 (HAUTAU)



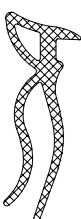

Brtila Gaskets

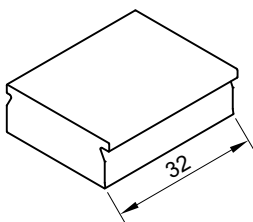
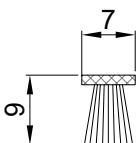
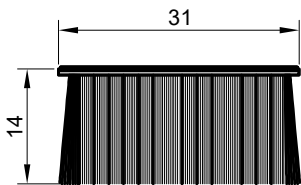
Oznaka Code	Izgled-presjek View- cross section	Opis Description	Materijal Material	Napomena Remark
321.002		- Brtva prema staklu /vanjska/ - Gasket to the glass /exterior/	EPDM	65
340.048		- Brtva - držač mreže komarice - Stara oznaka 00600/55 - Gasket - mosquito net holder - Former code 00600/55	TPE	65
341.013		- *Unutarnja brtvau donjem i vertikalnom pojasu krila FT-1120 - *Inside gasket in lower and vertical sash zone FT-1120 * Opcija korištenja brtve * Using a gasket (options)	EPDM	70
344.073		- Brtva na spoju dva krila - Gasket on connection of two sash	TPE	65
344.045		- Brtva u drvetu za prihvat staklo lajsne i prečke - Wood gasket for accepting glazing bead and mullion	(TPE) SEBS	85
344.049		- Brtva prema staklu /unutarnja, nosi 3.5-4.5 mm - Gasket to the glass /interior, carries 3.5-4.5 mm/	(TPE) SEBS	65

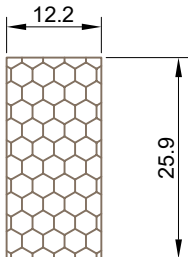
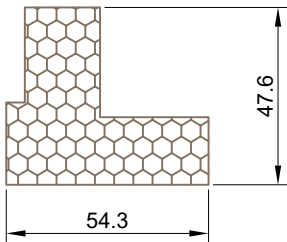
Oznaka Code	Izgled-presjek View- cross section	Opis Description	Materijal Material	Napomena Remark
344.061		- Brtva u ramu - Gasket in frame * Opcija korištenja brtve * Using a gasket (options)	EPDM	65
344.062		- Brtva na ramu FT-0433F - fiksni dio - Gasket on frame FT-0433F - fixed part	EPDM	65
344.063		- Unutarnja brtva - Interior gasket	EPDM	65
344.064		- Brtva na ramu FT-0433F ispod lajsne F-1417 - Gasket on frame FT-0433F under plate F-1417	EPDM	65
344.065		- Brtva na ramu FT-0433F - Gasket on frame FT-0433F	EPDM	65
344.067		- Brtva gornjeg pojasa krila prema ramu (TERMO 150 i TERMO 200 DA) - Upper zone gasket of sash to the frame (TERMO 150 and TERMO 200 DA) * Opcija korištenja brtve * Using a gasket (options)	TPE	65

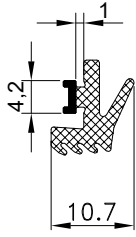
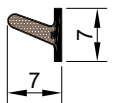
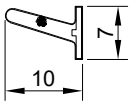
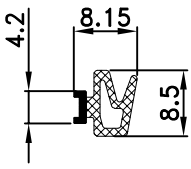
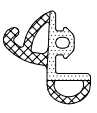
Oznaka Code	Izgled-presjek View- cross section	Opis Description	Materijal Material	Napomena Remark
344.044		<ul style="list-style-type: none"> - Gumeni umetak na profilu FT-0433F ispod krila TERMO 200 DA - Rubber insert on profile FT-0433F under sash TERMO 200 DA 	TPE	50
347.003		<ul style="list-style-type: none"> - Četkasta brtva 7x9 - Brush gasket 7x9 	PP	
347.009		<ul style="list-style-type: none"> - Četkasta brtva (samoljepljiva-za TERMO 200 DA) - Dim: 31x72x14 - Proizvođač: Schlegel - Brush gasket (self-adhesive -for TERMO 200 DA) - Dim: 31x72x14 - Produced by: Schlegel 		
340.013		<ul style="list-style-type: none"> - Ispuna po opsegu stakla - Izterm plamaframe - Insulation around the glass - Isoterm plamaframe 	PPE	
340.076		<ul style="list-style-type: none"> - Umetak u vertikalnom pojasu krila FT-0441 prema FT-0436F - Termoblok 25.9x12.2 za TERMO 200 DA - Insert in vertical sash field FT-0441 to the FT-0436F - Termoblock 25.9x12.2 for TERMO 200 DA 	XPS	
340.083		<ul style="list-style-type: none"> - Termoblok 54.3x47.6 za TERMO 200 DA (umetak ispod krila uz prečku) - Termoblock 54.3x47.6 for TERMO 200 DA (insert under the sash along mullion) 	XPS	



Oznaka Code	Izgled-presjek View- cross section	Opis Description	Materijal Material	Napomena Remark
344.106		<ul style="list-style-type: none"> -*Vanjska brtva u donjem i vertikalnom pojasu krila FT-1120 -*Outside gasket in lower and vertical sash zone FT-1120 <p>* Opcija korištenja brtve * Using a gasket (options)</p>	TPE	
347.011		<ul style="list-style-type: none"> - *Brtva (7 mm) - *Gasket (7 mm) 		
347.012		<ul style="list-style-type: none"> - *Brtva (10 mm) - *Gasket (10 mm) <p>* Opcija korištenja brtve * Using a gasket (options)</p>		
344.108		<ul style="list-style-type: none"> - Brtva u donjem pojasu krila FT-1120 - Gasket in lower sash zone FT-1120 	TPE	
327.003		<ul style="list-style-type: none"> - Brtva u krilu (TERMO 150 i TERMO 200 DA) - Gasket in sash (TERMO 150 i TERMO 200 DA) 	EPDM -Coex	
348.067		<ul style="list-style-type: none"> - Brtva gornjeg pojasa krila prema ramu (TERMO 150 i TERMO 200 DA) - Upper zone gasket of sash to the frame (TERMO 150 and TERMO 200 DA) 	EPDM	

Oznaka Code	Izgled-presjek View- cross section	Opis Description	Materijal Material	Napomena Remark
348.061		- Brtva u ramu - Gasket in frame	EPDM	

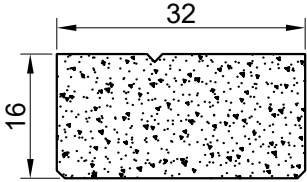
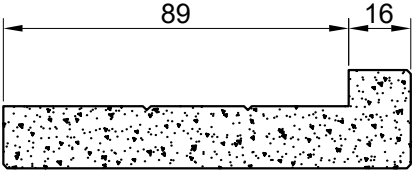
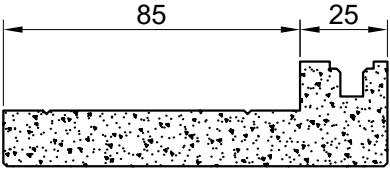
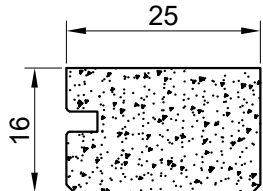
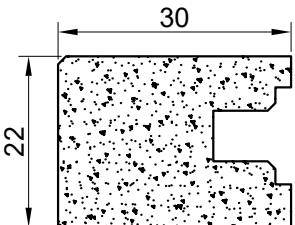
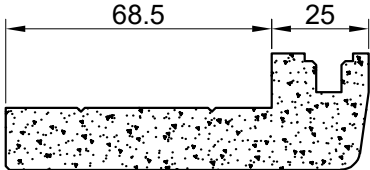
Dodaci Accessories

Oznaka Code	Izgled-presjek View-cross section	Opis Description	Materijal Material	Napomena Remark
600.011.01 .02		- Drvena obloga rama FT-0430F, FT-0431F i FT-0432F - Wooden covering of frame FT-0430F, FT-0431F and FT-0432F	Hrast Oak Ayous	
600.012.01 .02		- Drvena obloga krila FT-0436F uz prečku FT-0440F i FT-0442F - Wooden covering of sash FT-0436F to the mullion FT-0440F and FT-0442F	Hrast Oak Ayous	
600.013.01 .02		- Drvena obloga prečke FT-0440F - Wooden covering of mullion FT-0440F	Hrast Oak Ayous	
600.015.01 .02		- Drvena obloga krila FT-0433F - Wooden covering of sash FT-0433F	Hrast Oak Ayous	
600.016.01 .02		- Drvena obloga prečke FT-0442F i staklo lajsne na fiksnom dijelu - Wooden covering of mullion FT-0442F and glass plate on fixed part	Hrast Oak Ayous	
600.017.01 .02		- Drvena obloga krila FT-0436F uz prečku FT-0440F - Wooden covering of sash FT-0436F to the mullion FT-0440F	Hrast Oak Ayous	

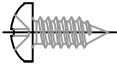
Oznaka Code	Izgled-presjek View-cross section	Opis Description	Materijal Material	Napomena Remark
600.018.01 .02		<ul style="list-style-type: none"> - Drvena obloga rama FT-0431F i prečke FT-0445F - Wooden covering of frame FT-0431F and mulion FT-0445F 	Hrast Oak Ayous	
600.020.01 .02		<ul style="list-style-type: none"> - Drvena obloga rama FT-0433F - Wooden covering of frame FT-0433F 	Hrast Oak Ayous	
600.021.01 .02		<ul style="list-style-type: none"> - Drvena obloga rama FT-0432F - Wooden covering of frame FT-0432F 	Hrast Oak Ayous	
600.030.01 .02		<ul style="list-style-type: none"> - Drvena obloga rama FT-0446F - Wooden covering of frame FT-0446F 	Hrast Oak Ayous	
521.209		<ul style="list-style-type: none"> - Bočni čep za kadice za klizni sistem TERMO 200 DA - Side sill cap for sliding system TERMO 200 DA 	Al.	

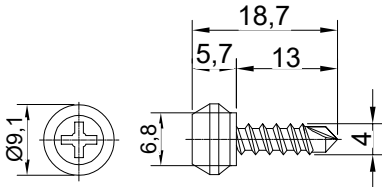
Oznaka Code	Opis Description	Izgled-presjek View-cross section	Materijal Material	Napomena Remark
433.004	Vijak 3.5x16 DIN 7981 Screw 3.5x16 DIN 7981		INOX A2	
433.020	Vijak 3.9x25 DIN 7981 Screw 3.9x25 DIN 7981		INOX A2	
433.022	Vijak 3.9x38 DIN 7981 Screw 3.9x38 DIN 7981		INOX A2	
433.033	Vijak 4.2x32 DIN 7981 Screw 4.2x32 DIN 7981		INOX A2	
433.050	Vijak 4.8x60 DIN 7981 Screw 4.8x60 DIN 7981		INOX A2	
433.104	Vijak 3.9x13 DIN 7982 Screw 3.9x13 DIN 7982		INOX A2	
433.105	Vijak 3.9x16 DIN 7982 Screw 3.9x16 DIN 7982		INOX A2	
433.108	Vijak 3.9x25 DIN 7982 Screw 3.9x25 DIN 7982		INOX A2	
433.122	Vijak 4.2x38 DIN 7982 Screw 4.2x38 DIN 7982		INOX A2	
433.202	Vijak za drvo 3.0x10.0 Screw for wood 3.0x16.0		INOX A2	
433.201	Vijak za drvo 3.0x16.0 Screw for wood 3.0x16.0		INOX A2	
433.199	Vijak za drvo 3.0x25.0 Screw for wood 3.0x16.0		INOX A2	
433.204	Vijak za klipsanje 4.0x13 Screw for clipping 4.0x13		INOX A2	

Presjeci

Cross sections

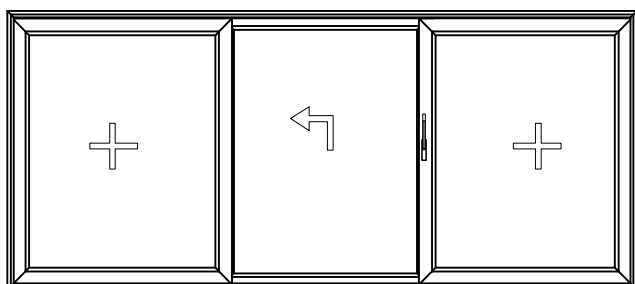
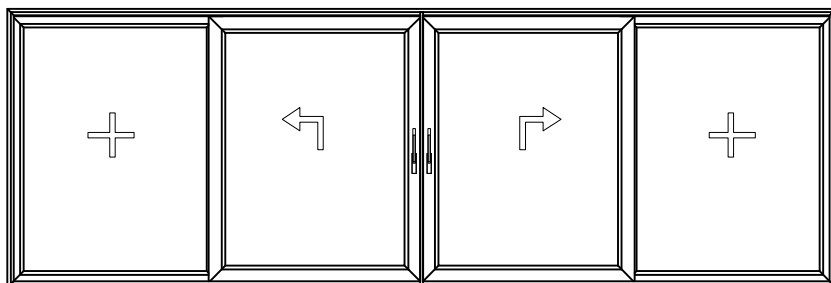
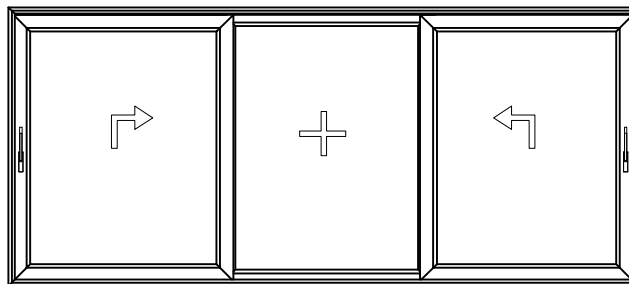
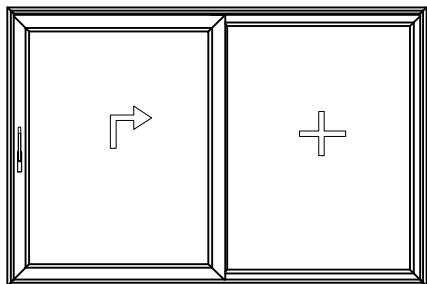

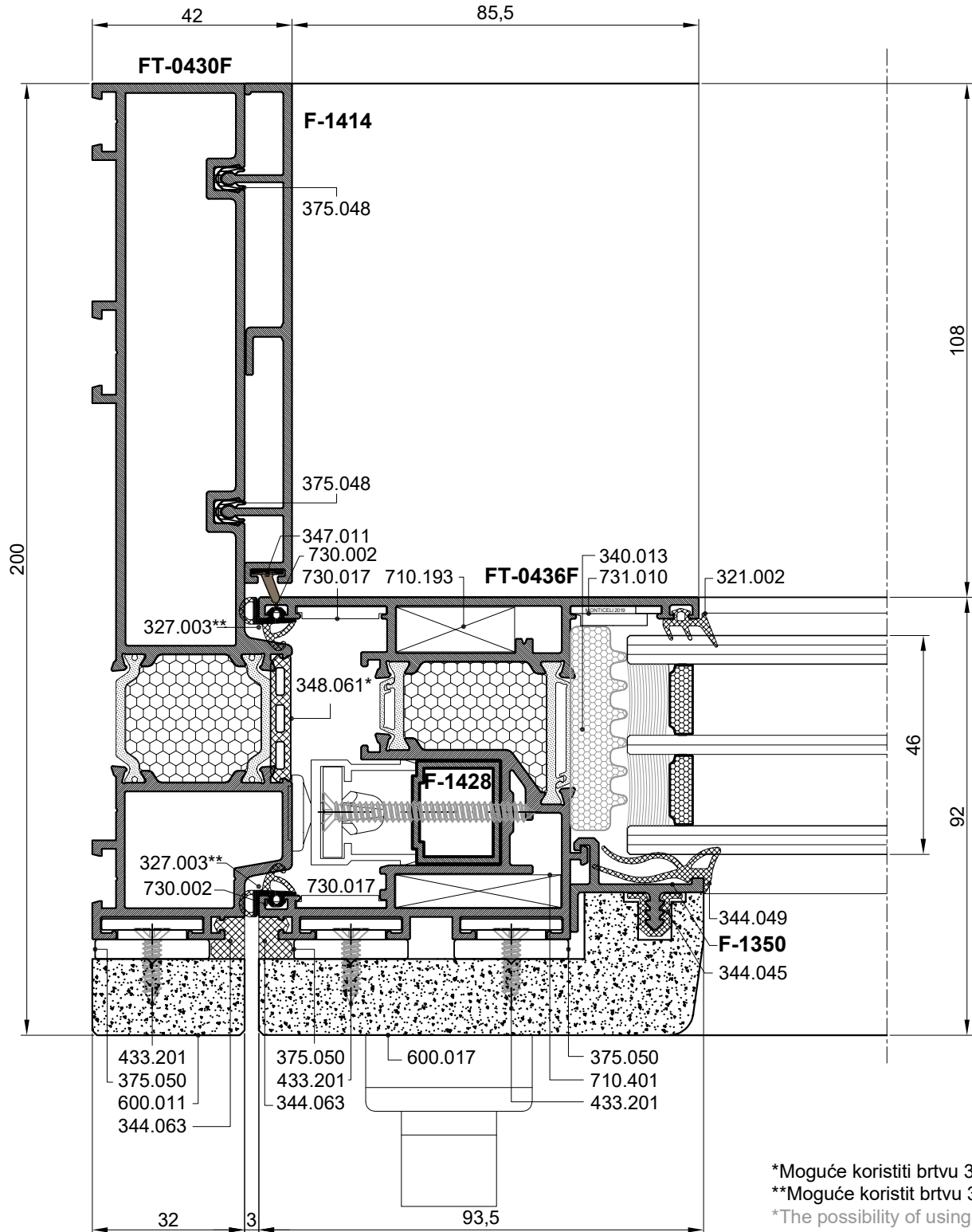
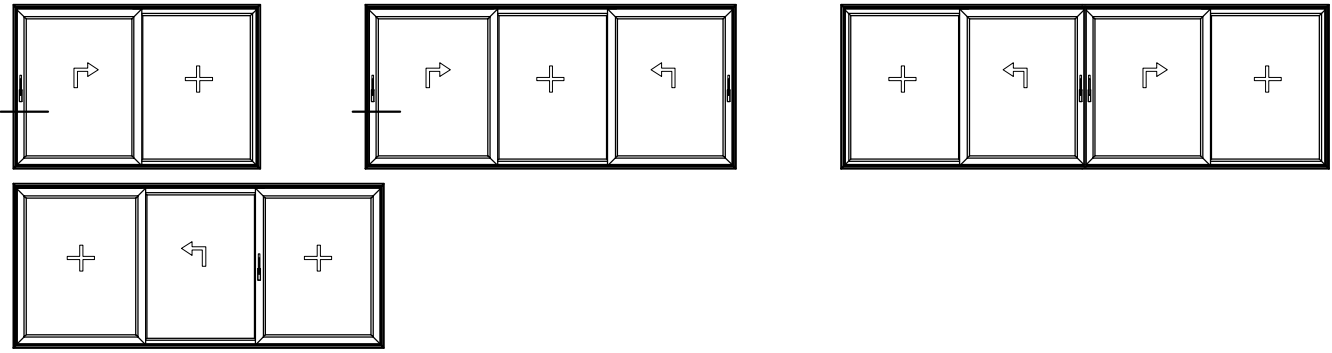

*Moguće koristiti brtvu 344.061

**Moguće koristiti brtvu 344.108

*The possibility of using a gasket 344.061

**The possibility of using a gasket 344.108

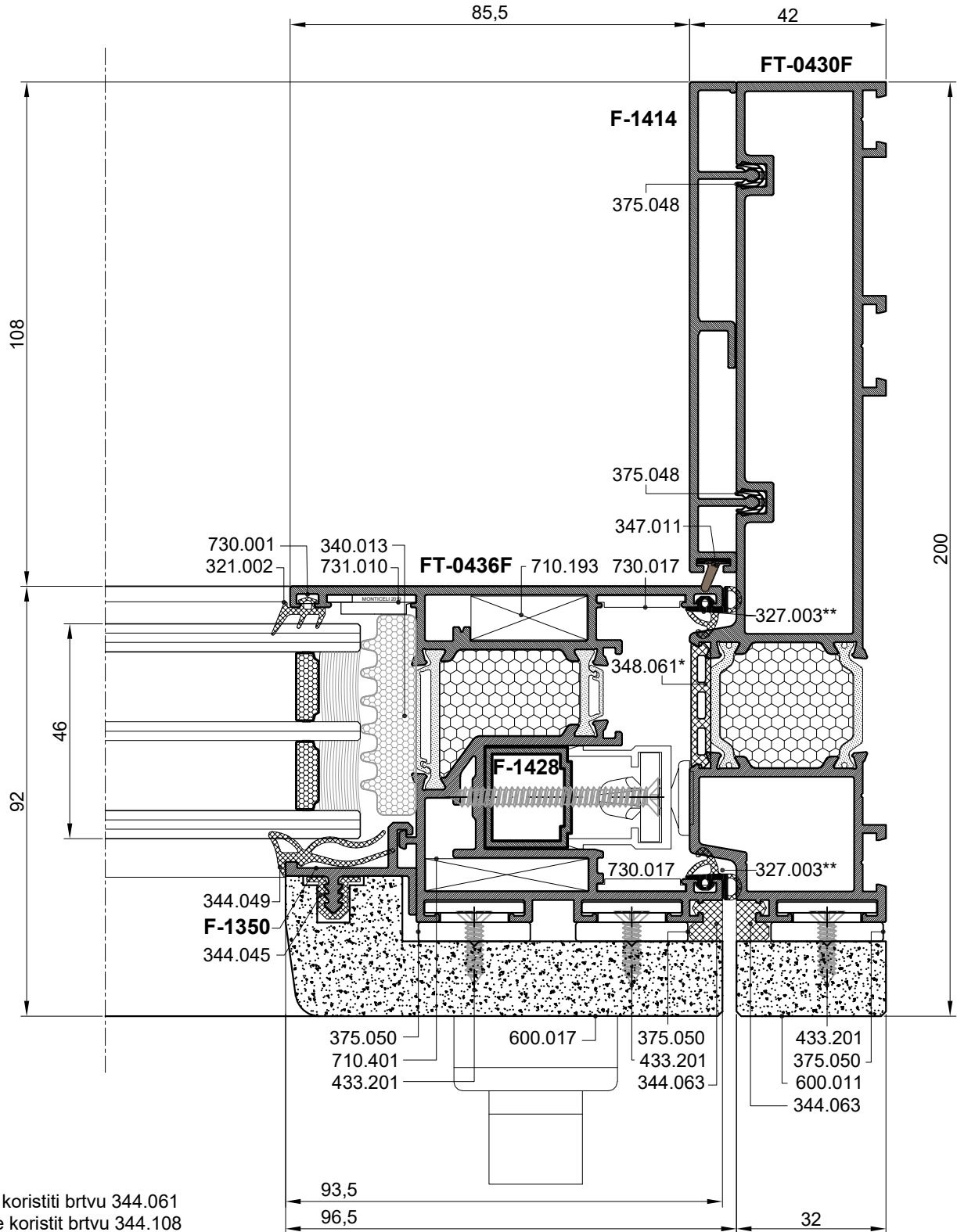
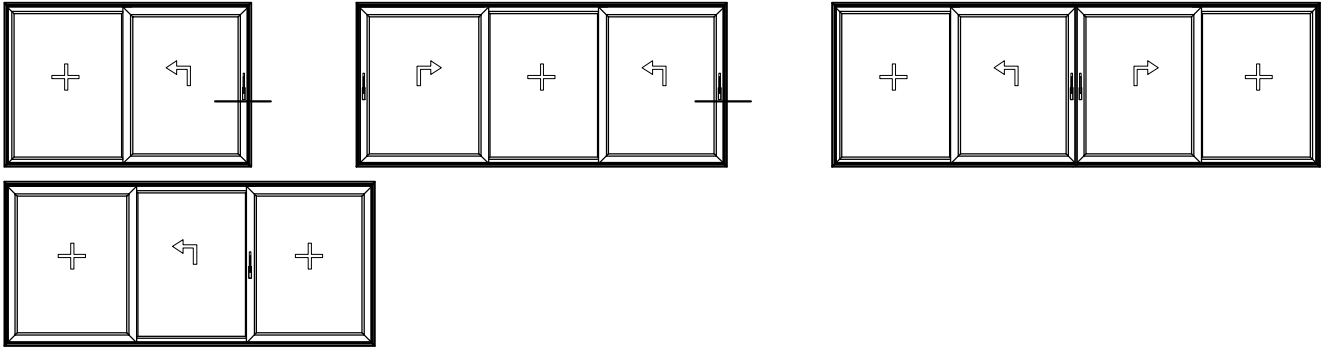

*Moguće koristiti brtvu 344.061

**Moguće koristiti brtvu 344.108

*The possibility of using a gasket 344.061

**The possibility of using a gasket 344.108

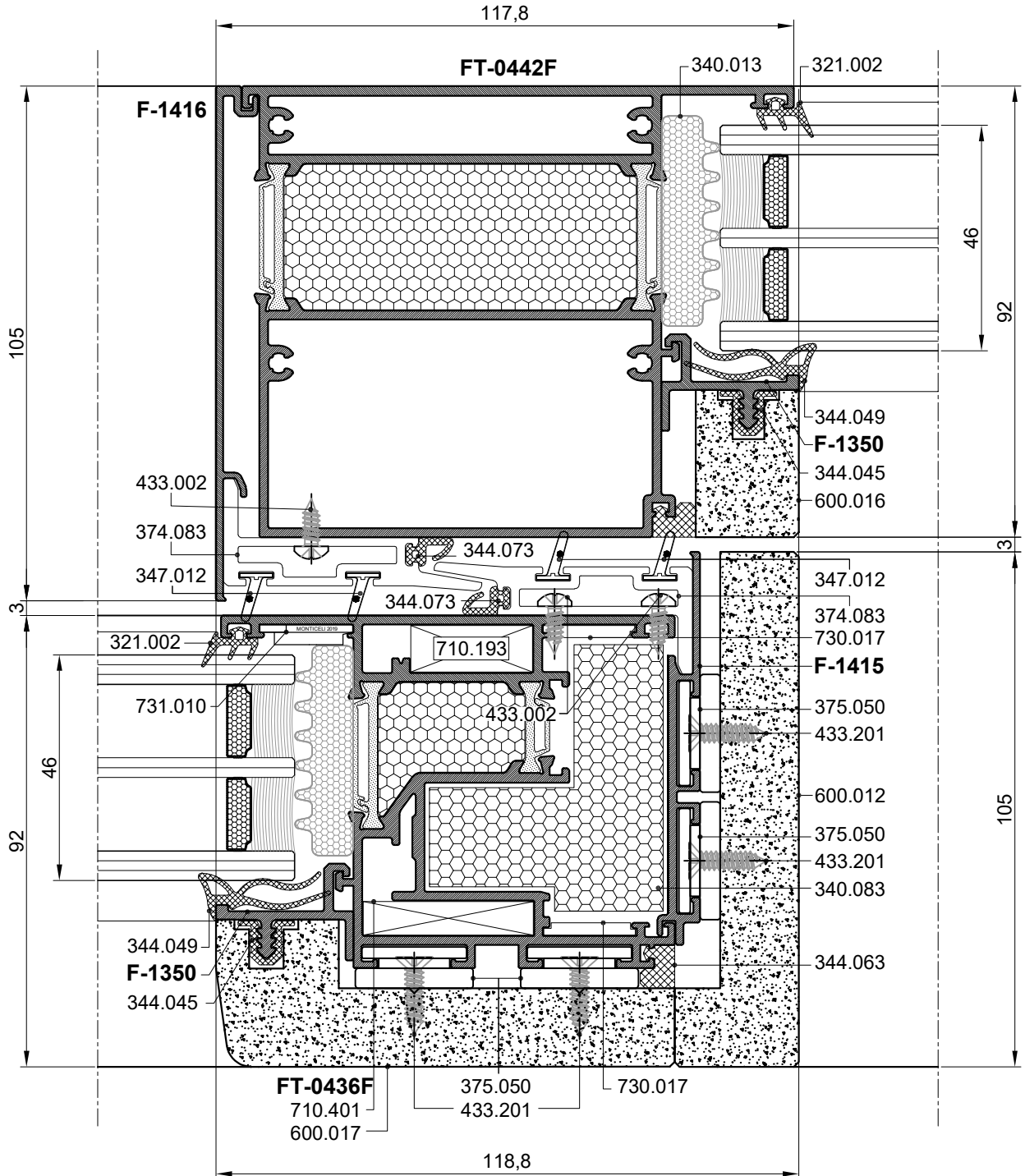
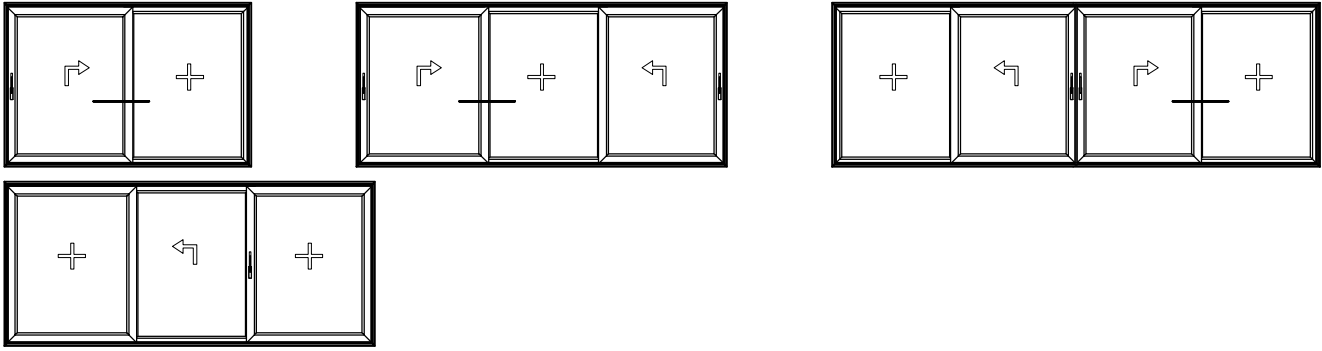

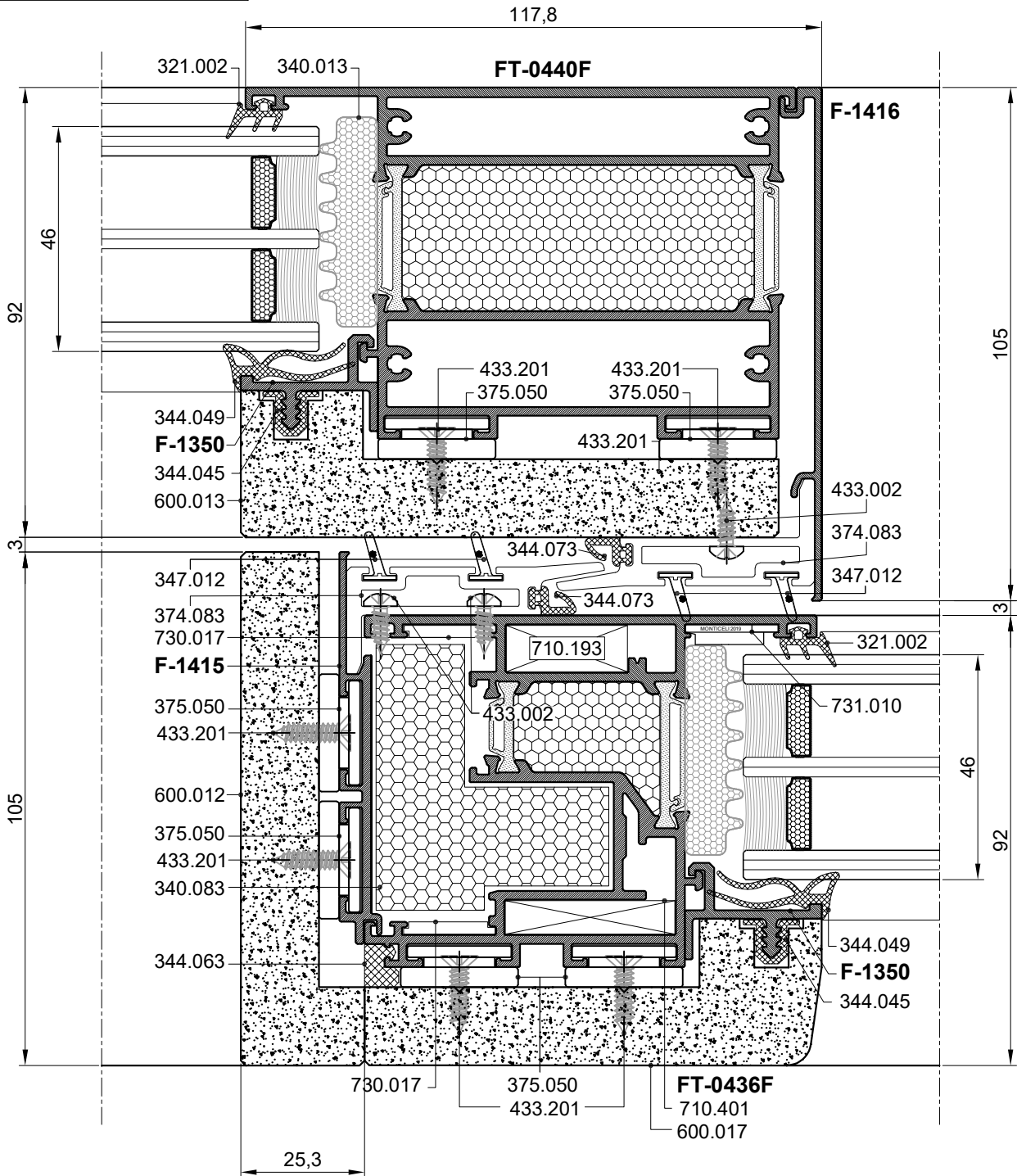
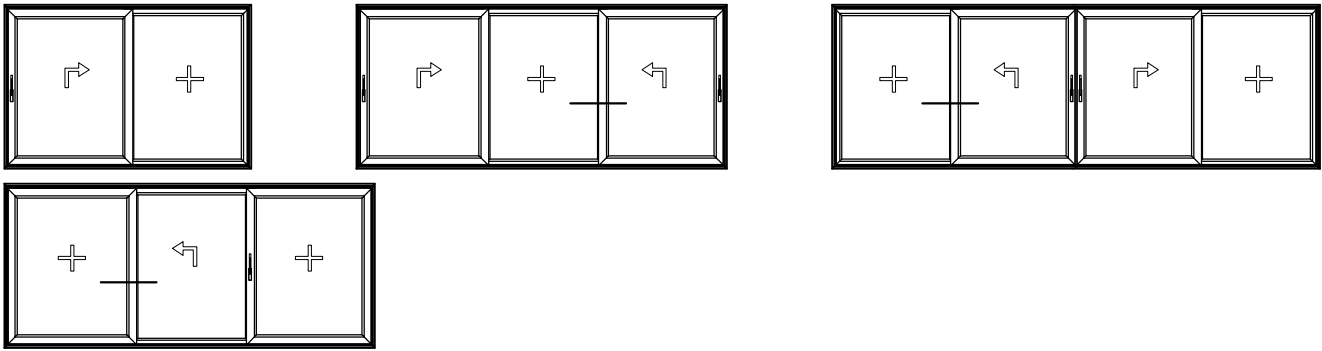

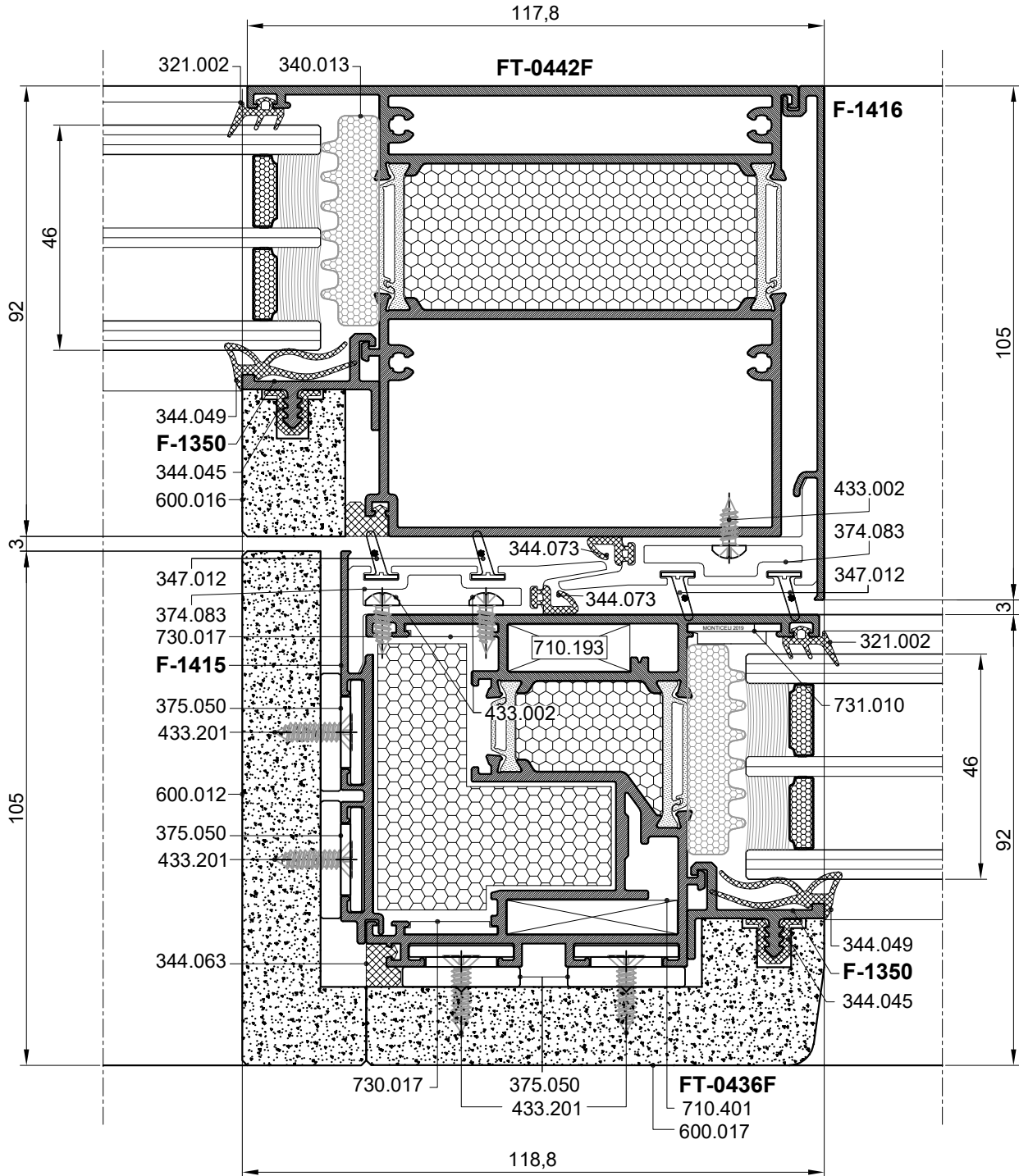
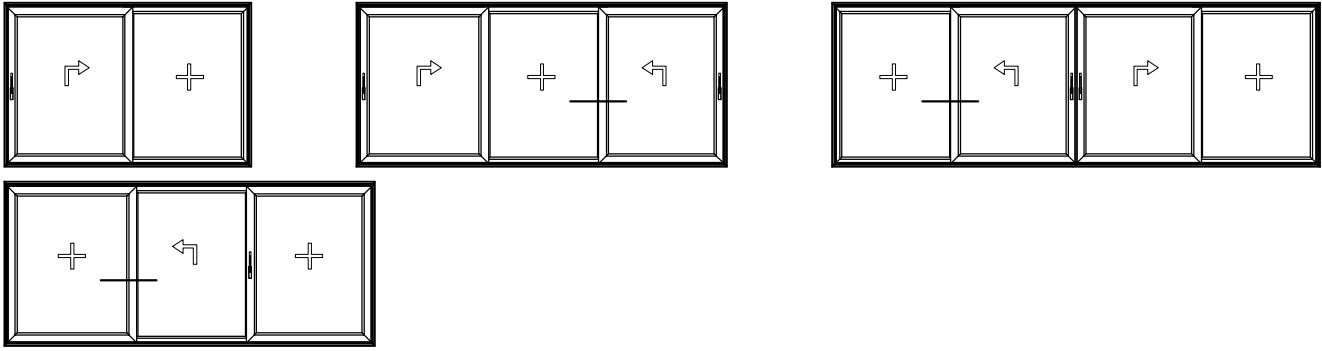

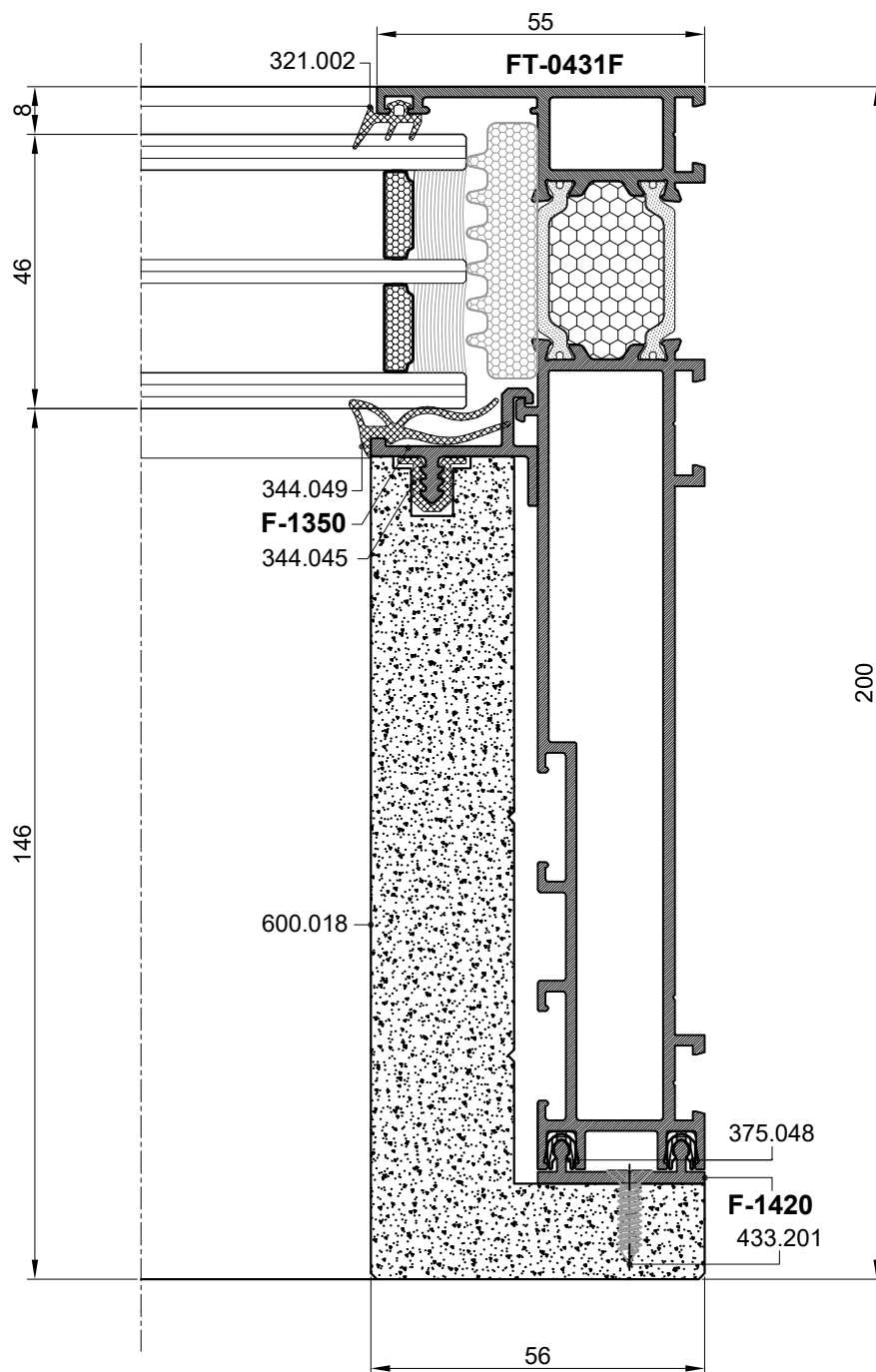
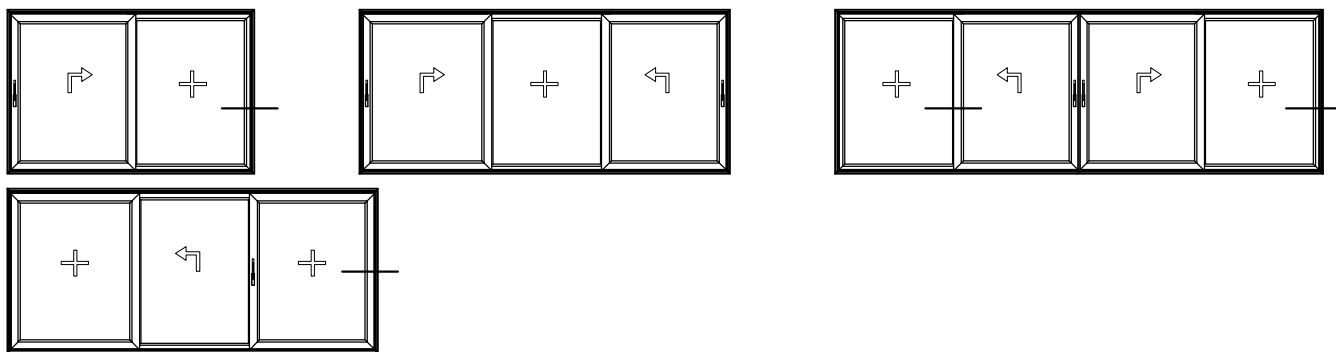

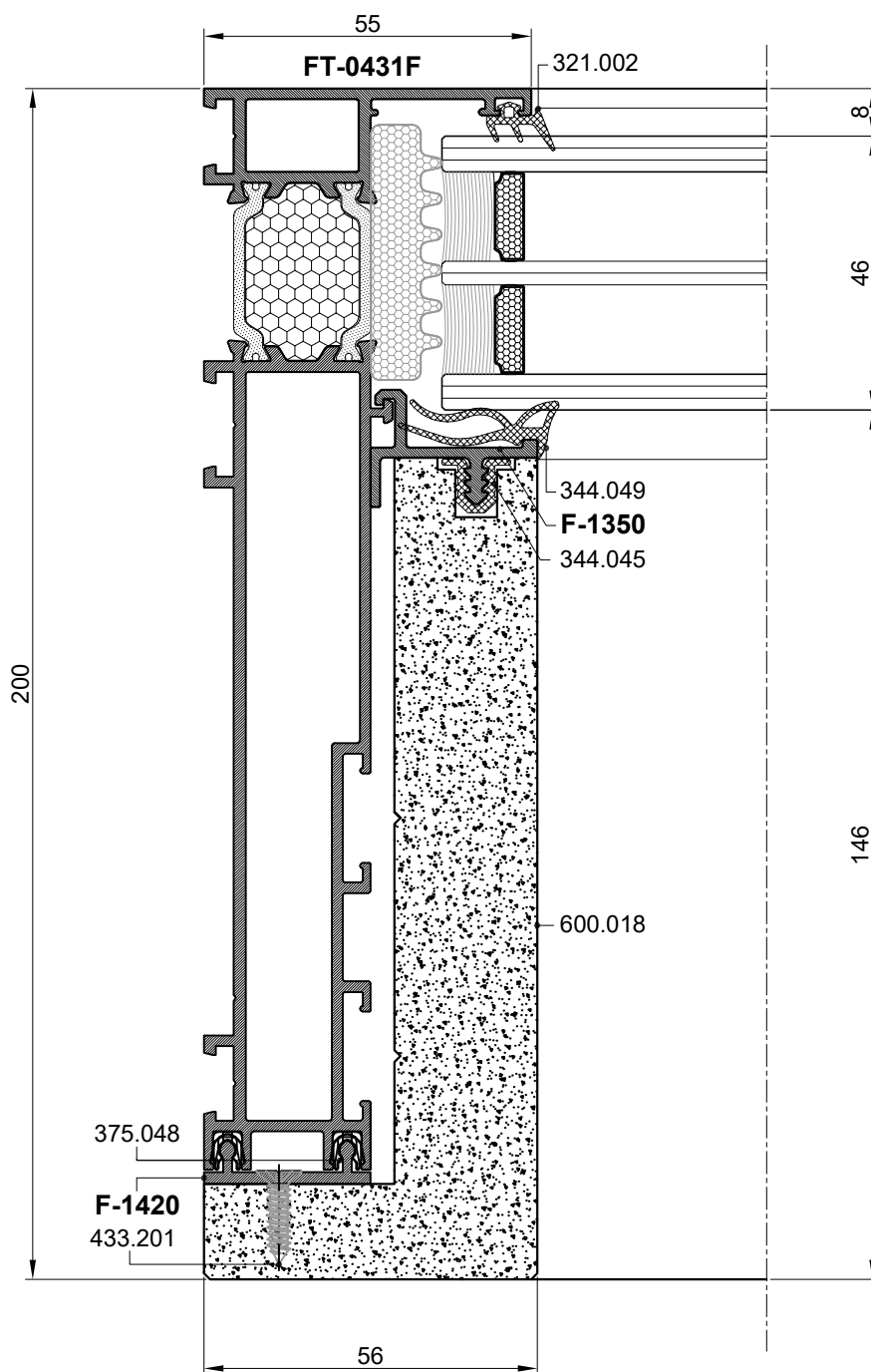
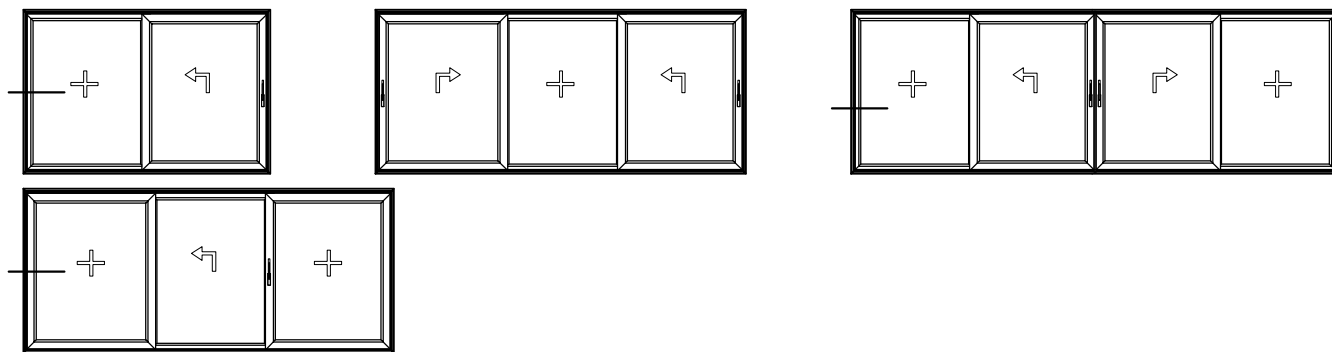

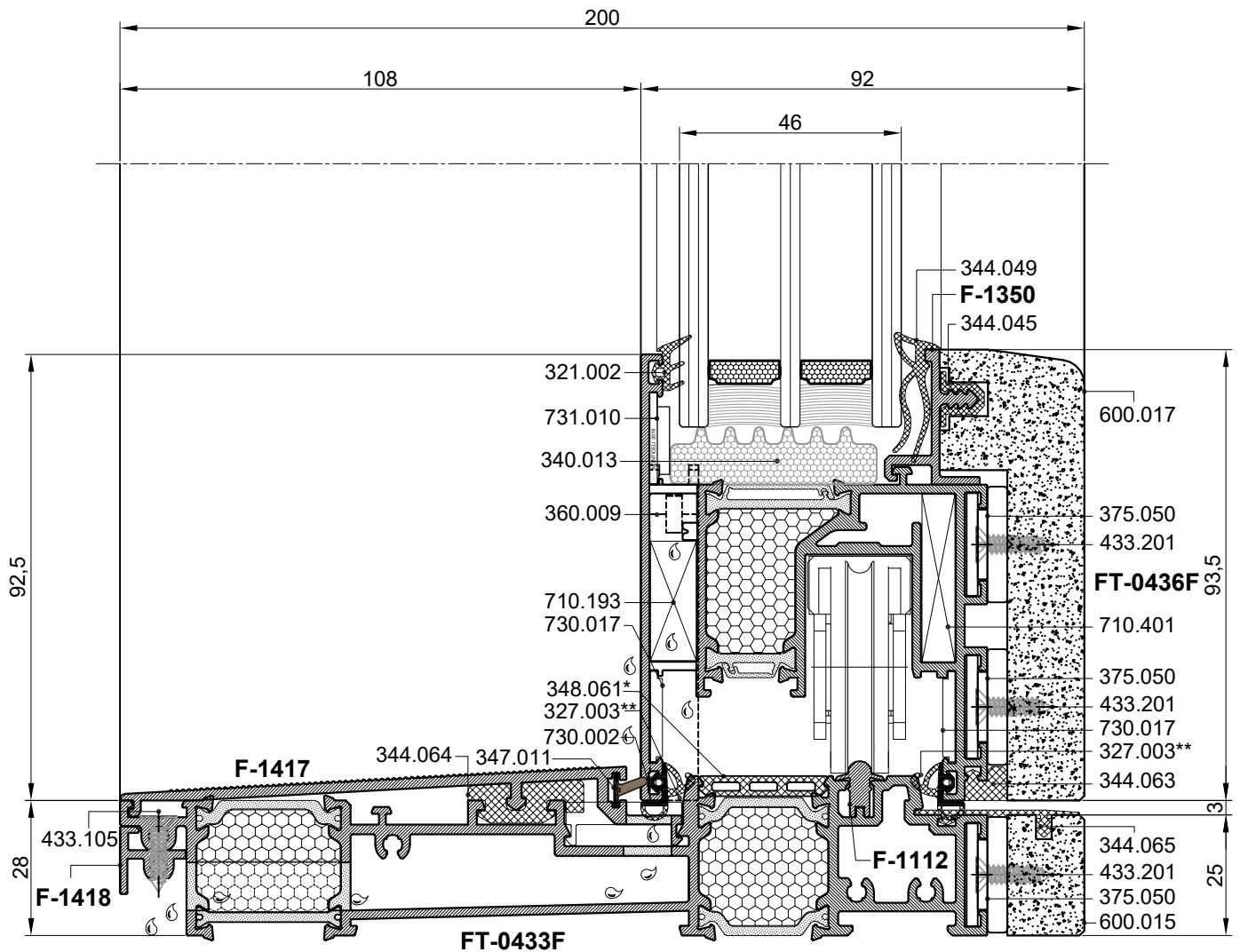
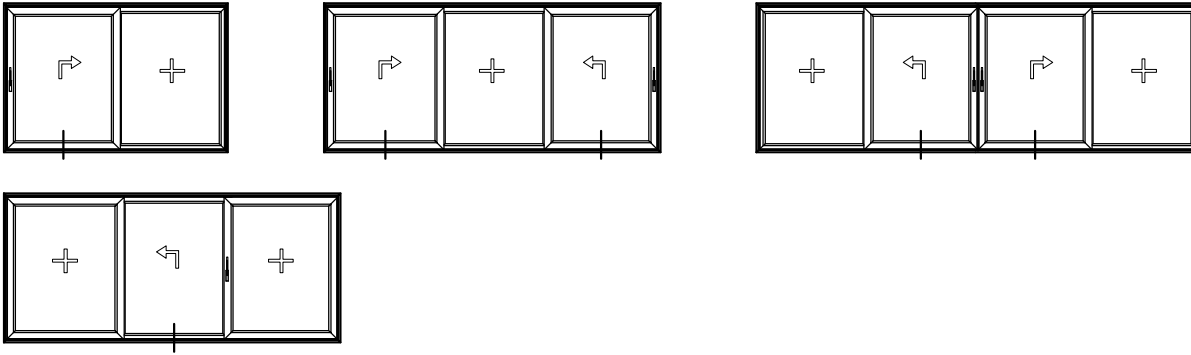

*Moguće koristiti brtvu 344.061

**Moguće koristiti brtvu 344.108

*The possibility of using a gasket 344.061

**The possibility of using a gasket 344.108

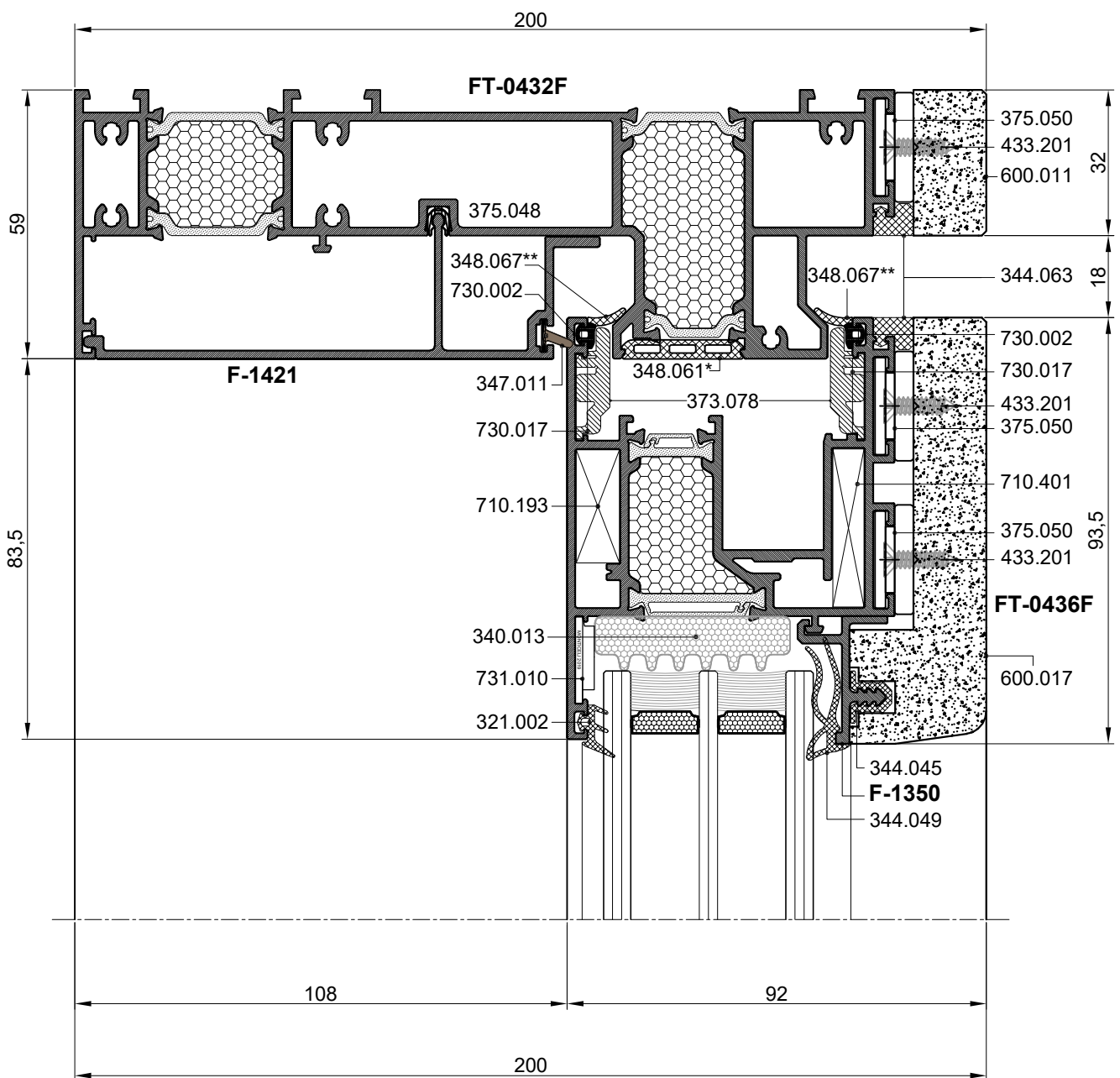
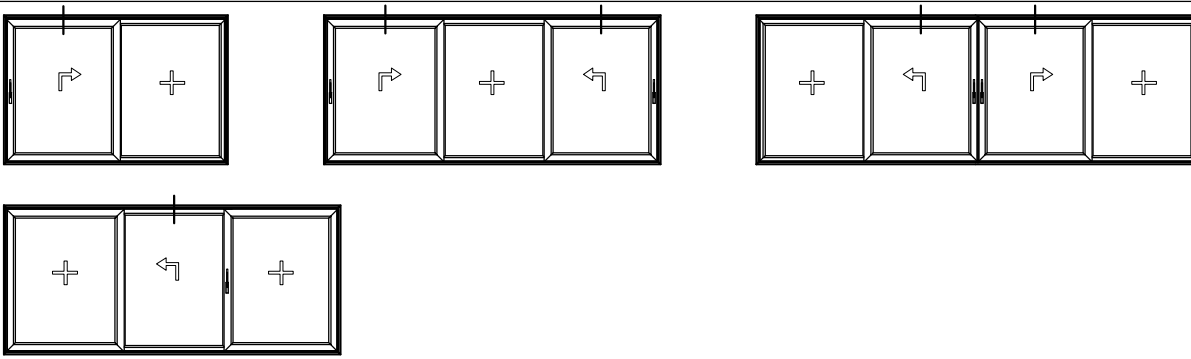

*Moguće koristiti brtvu 344.061

**Moguće koristiti brtvu 344.067

*The possibility of using a gasket 344.061

**The possibility of using a gasket 344.067

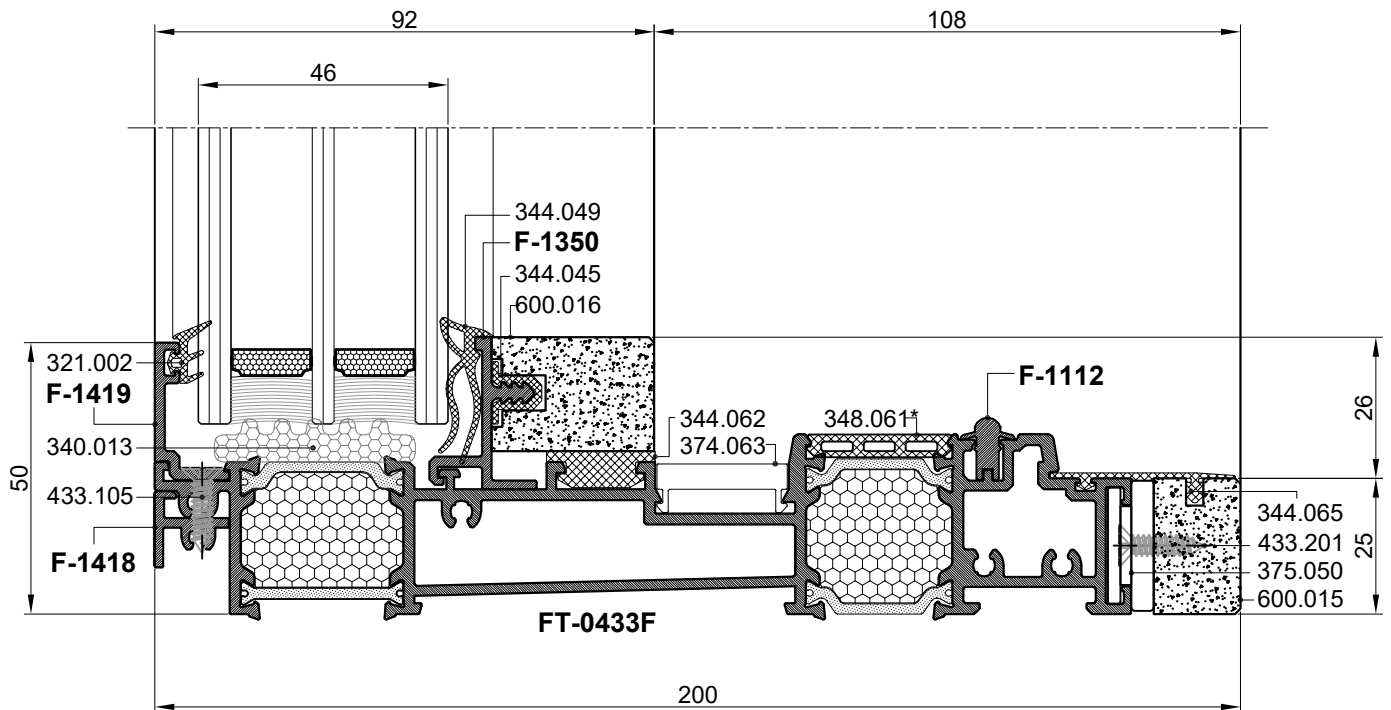
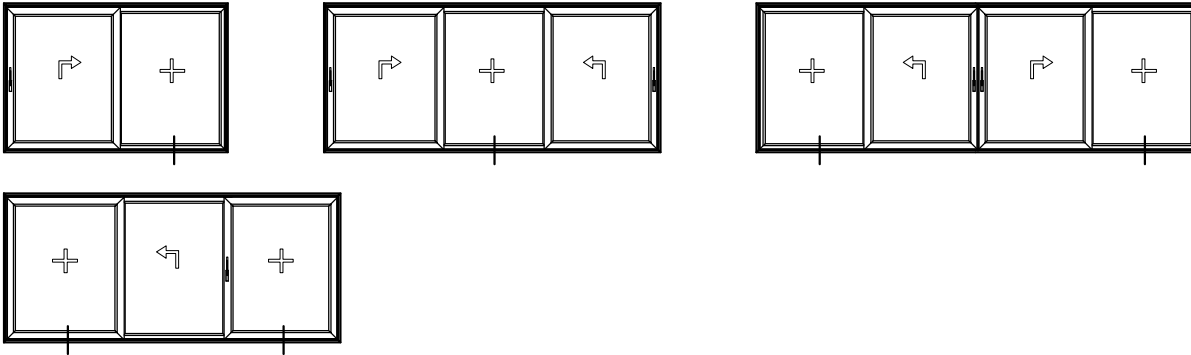

*Moguće koristiti brtvu 344.061

*The possibility of using a gasket 344.061

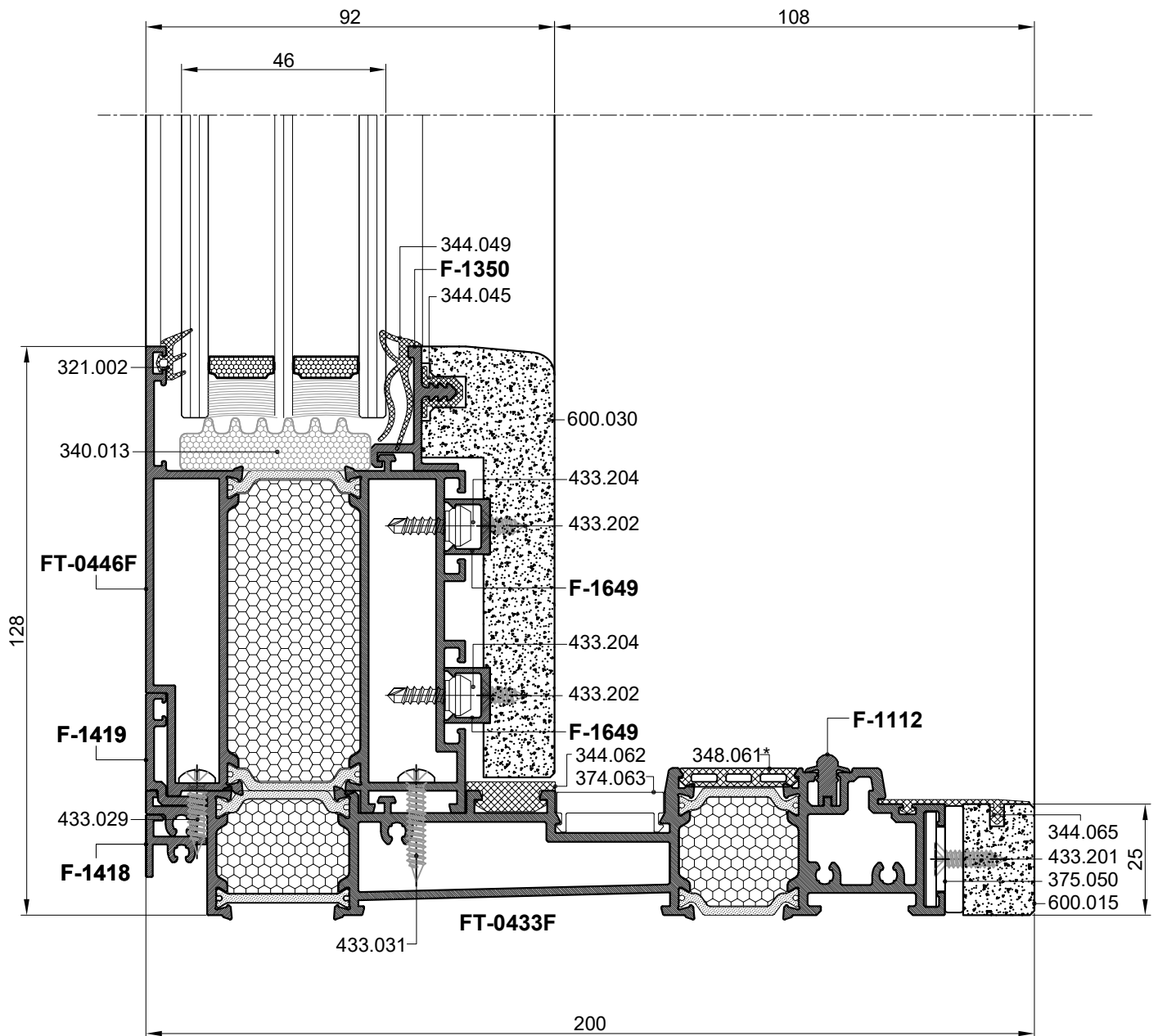
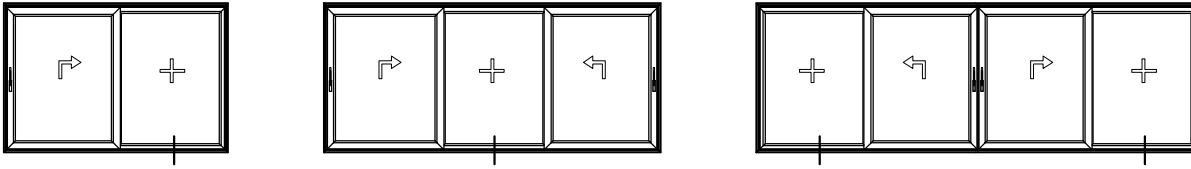

*Moguće koristiti brtvu 344.061

*The possibility of using a gasket 344.061

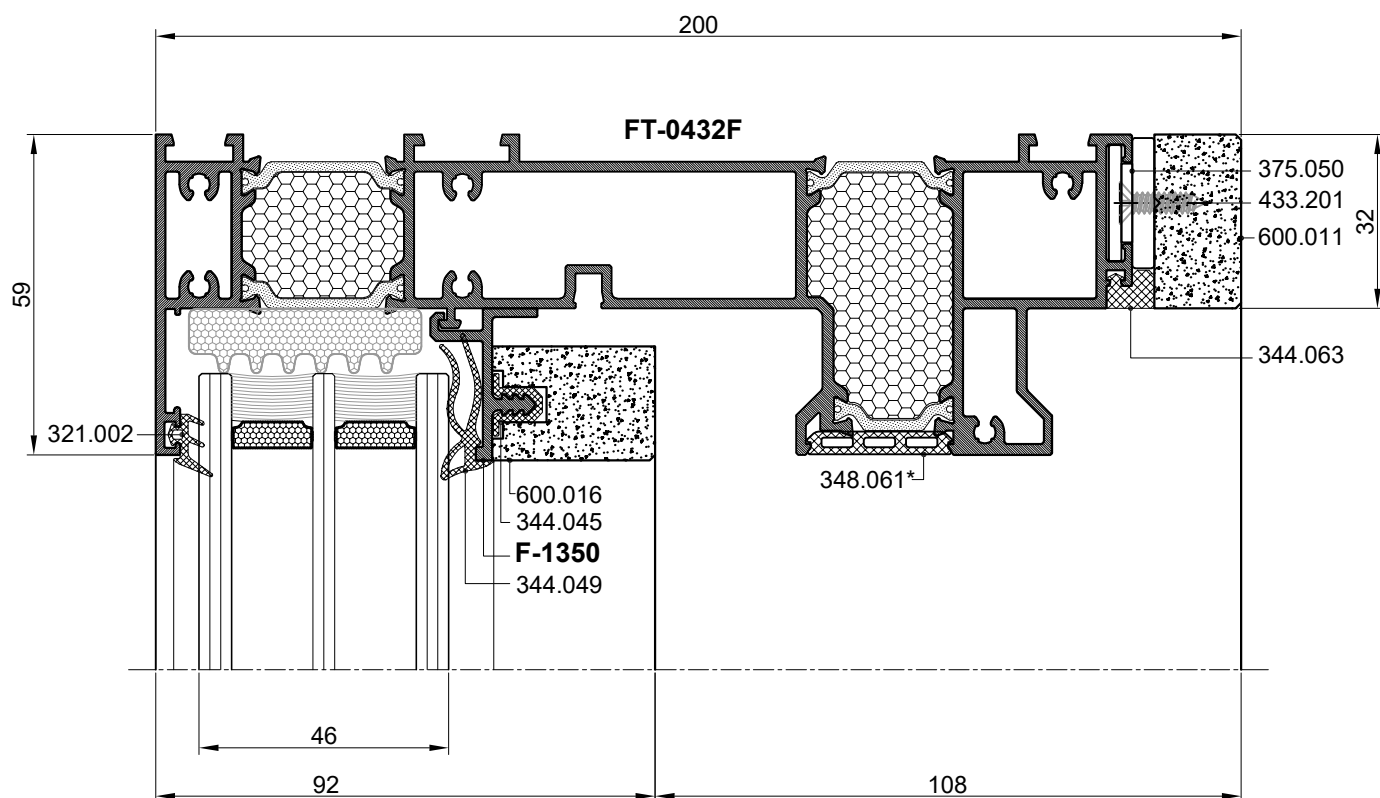
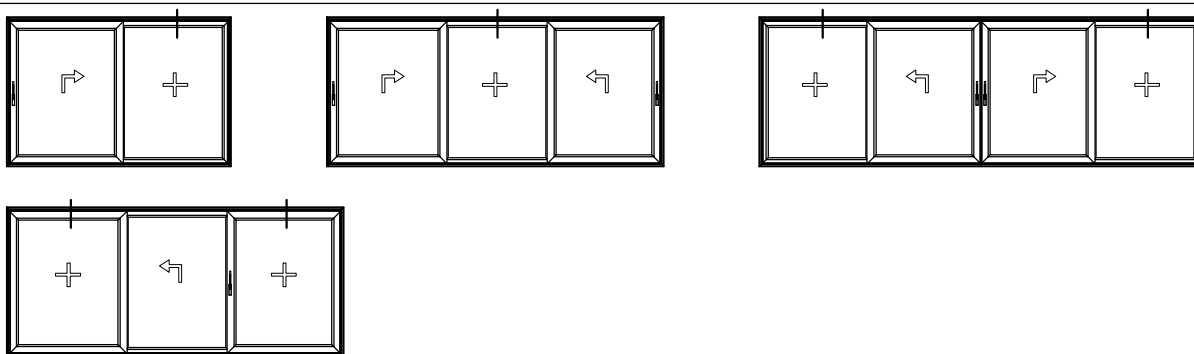

*Moguće koristiti brtvu 344.061

*The possibility of using a gasket 344.061

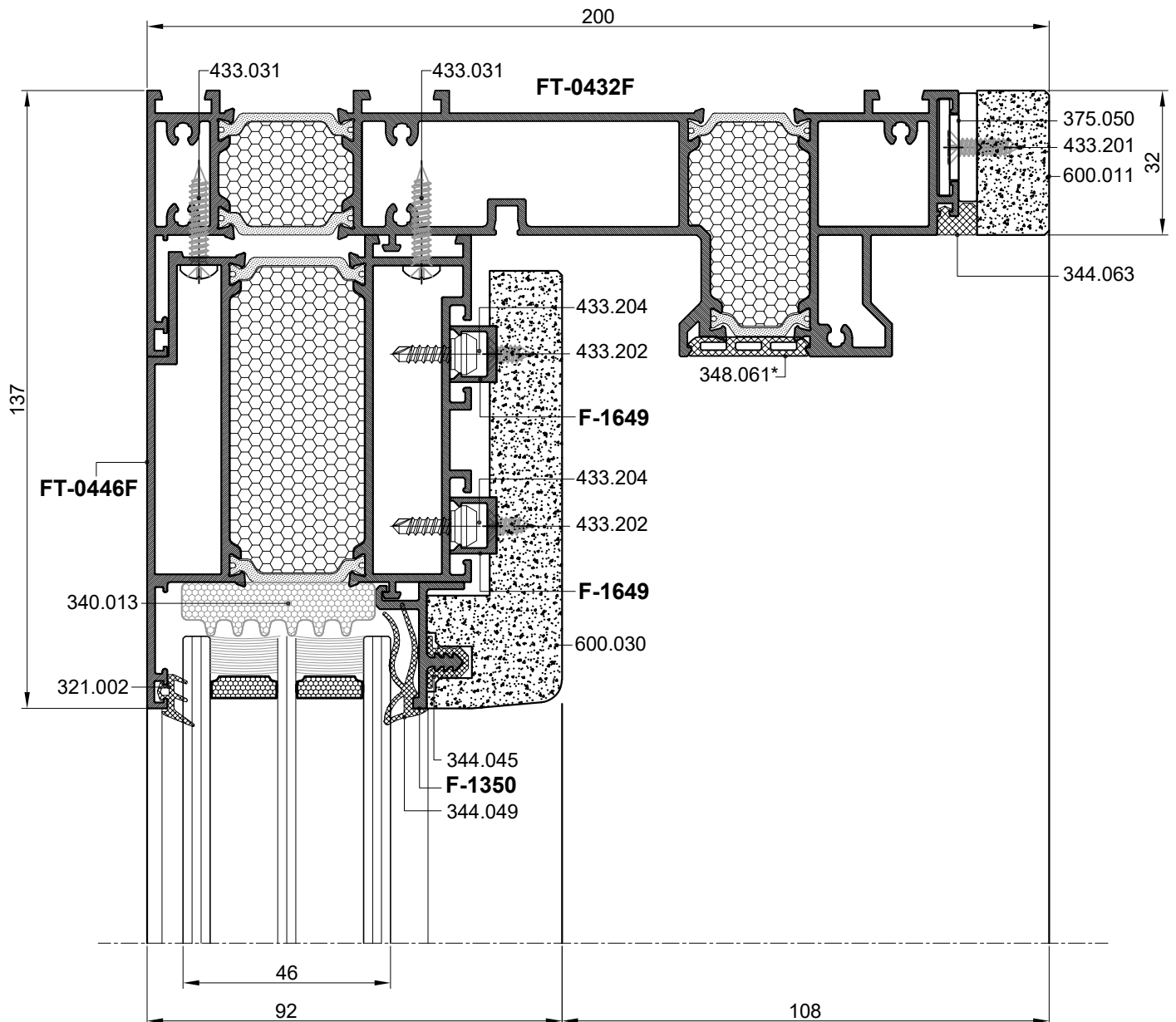
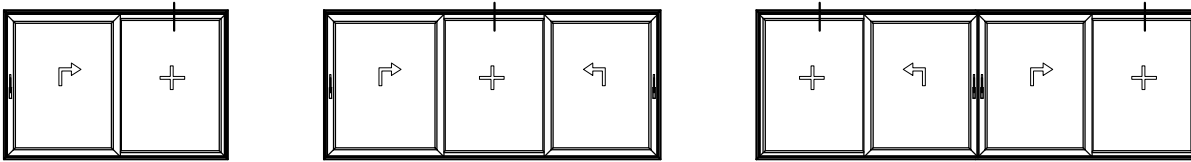

*Moguće koristiti brtvu 344.061

*The possibility of using a gasket 344.061

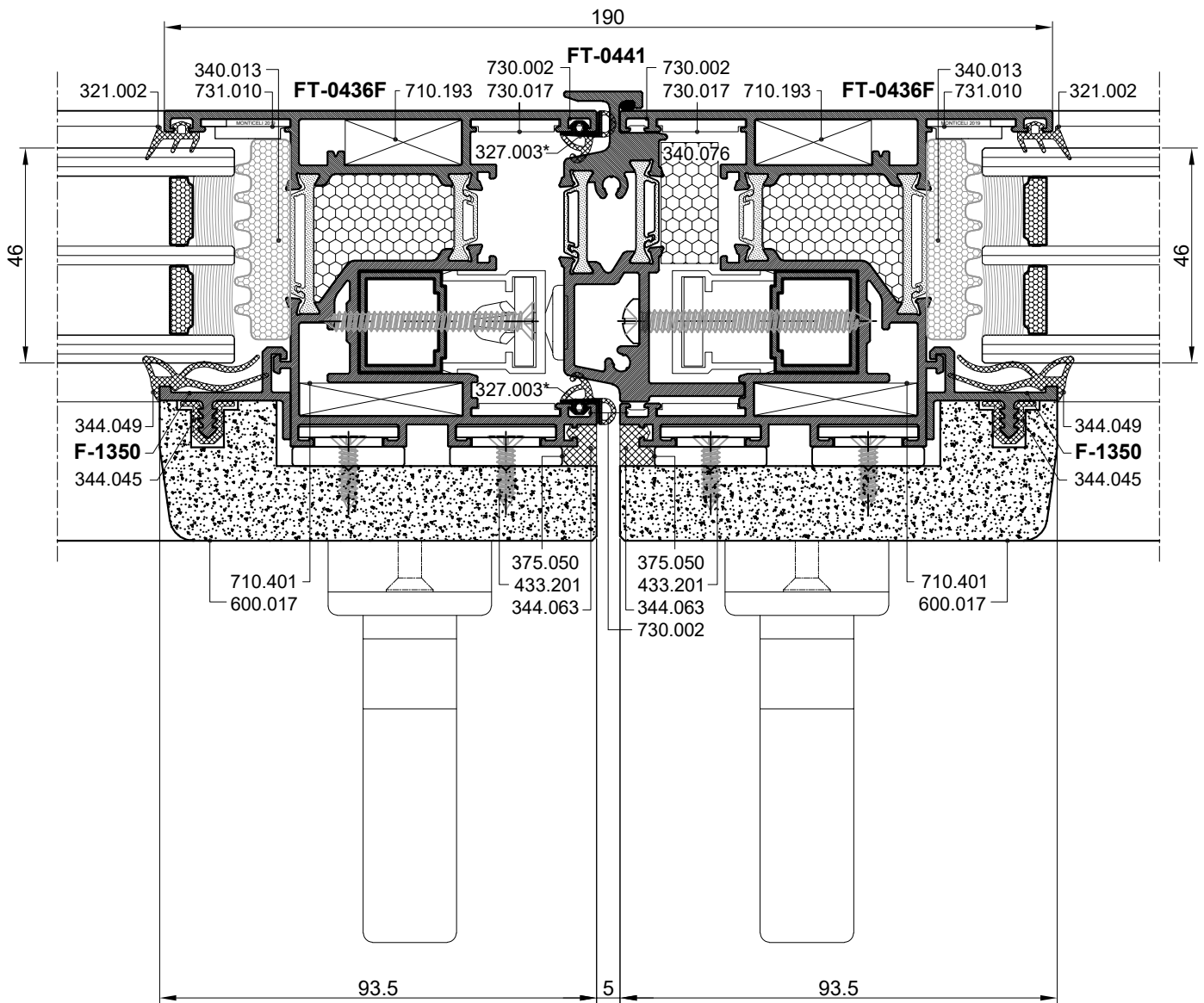
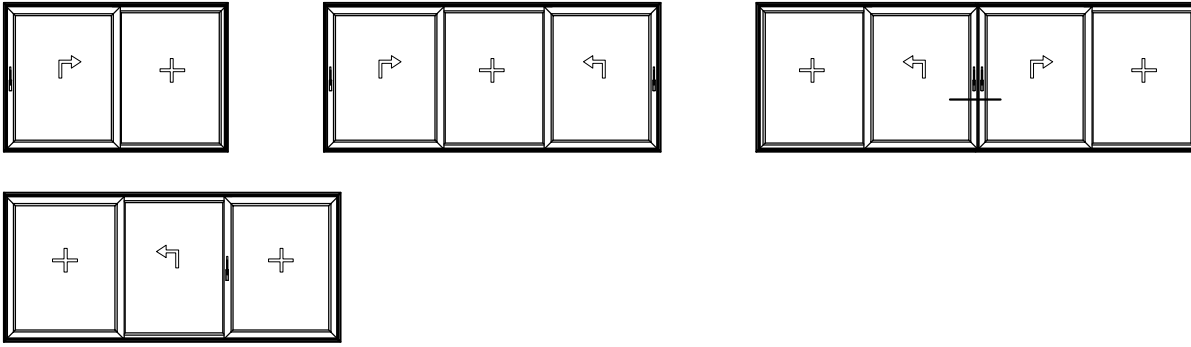

*Moguće koristiti brtvu 344.108

*The possibility of using a gasket 344.108

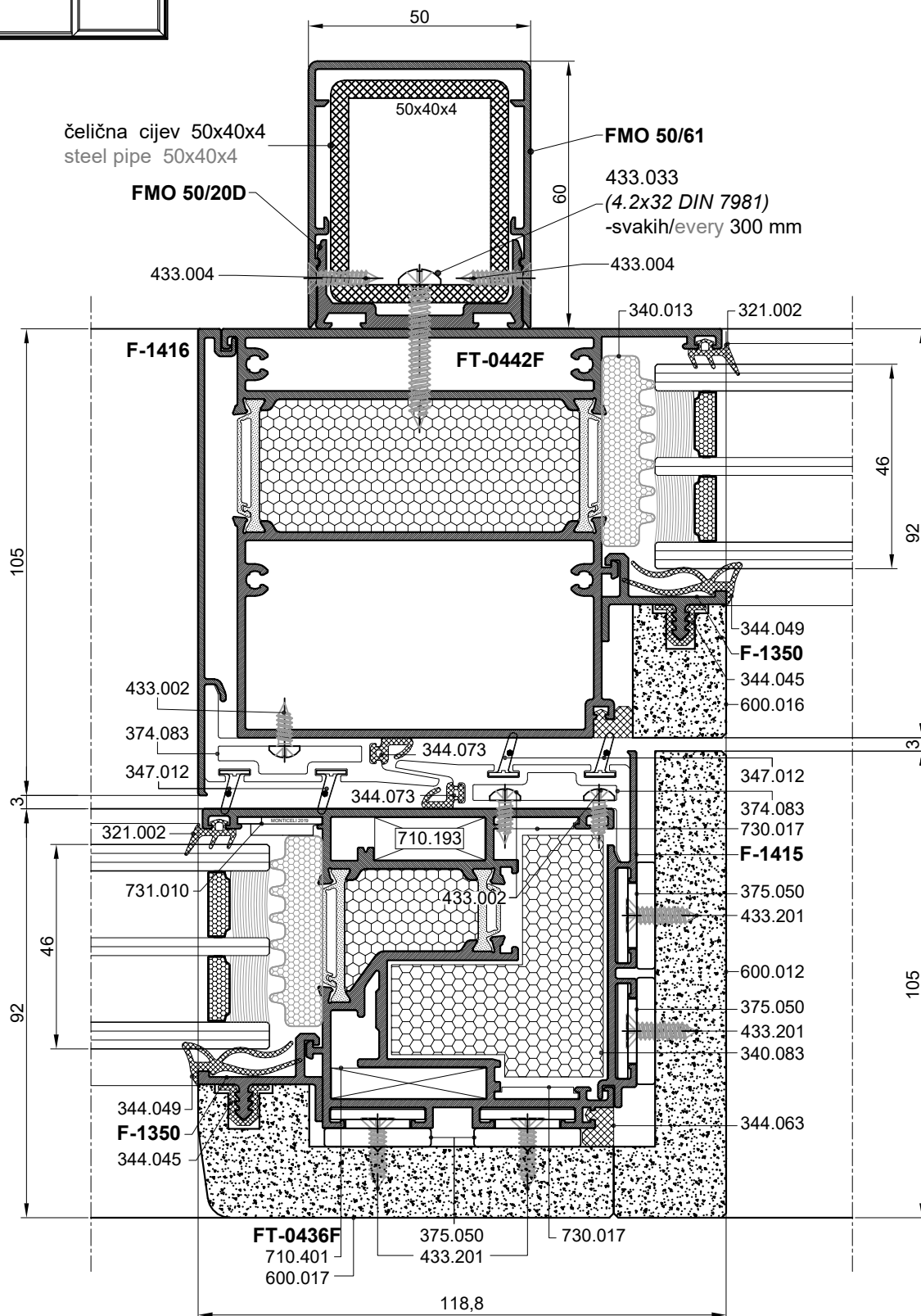
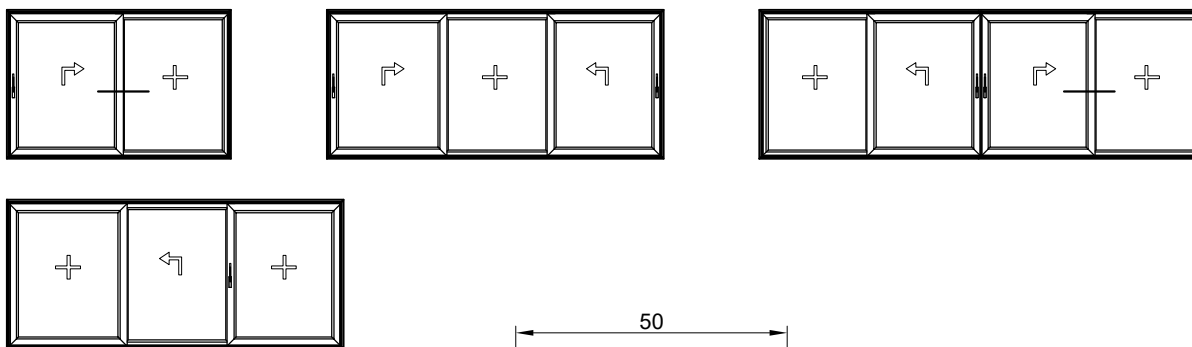

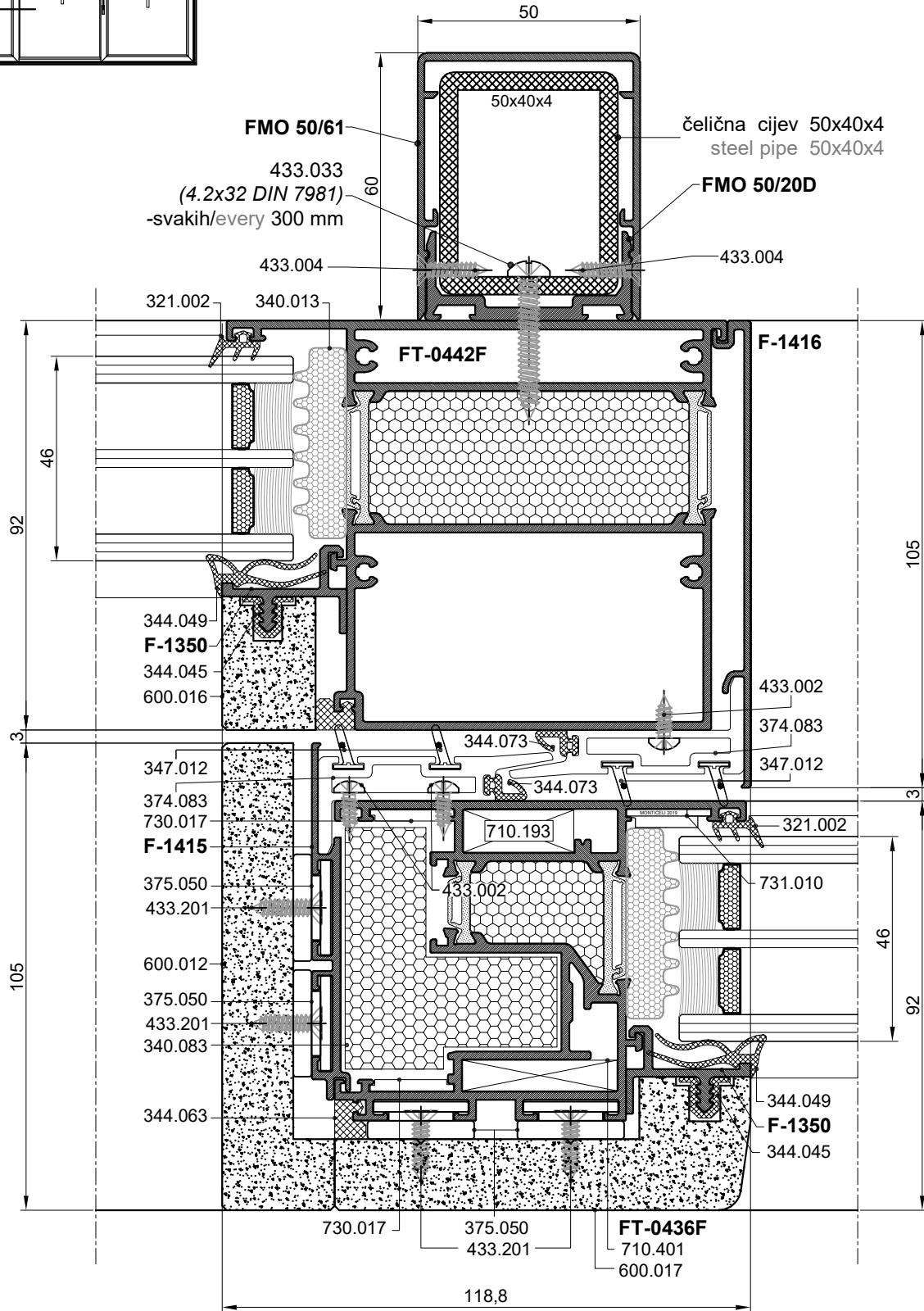
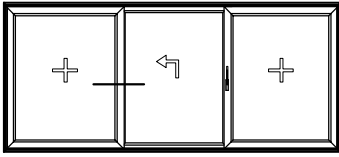
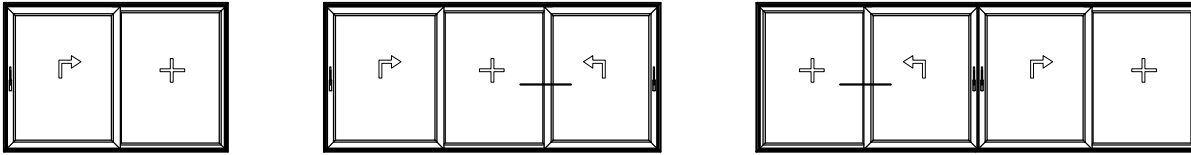

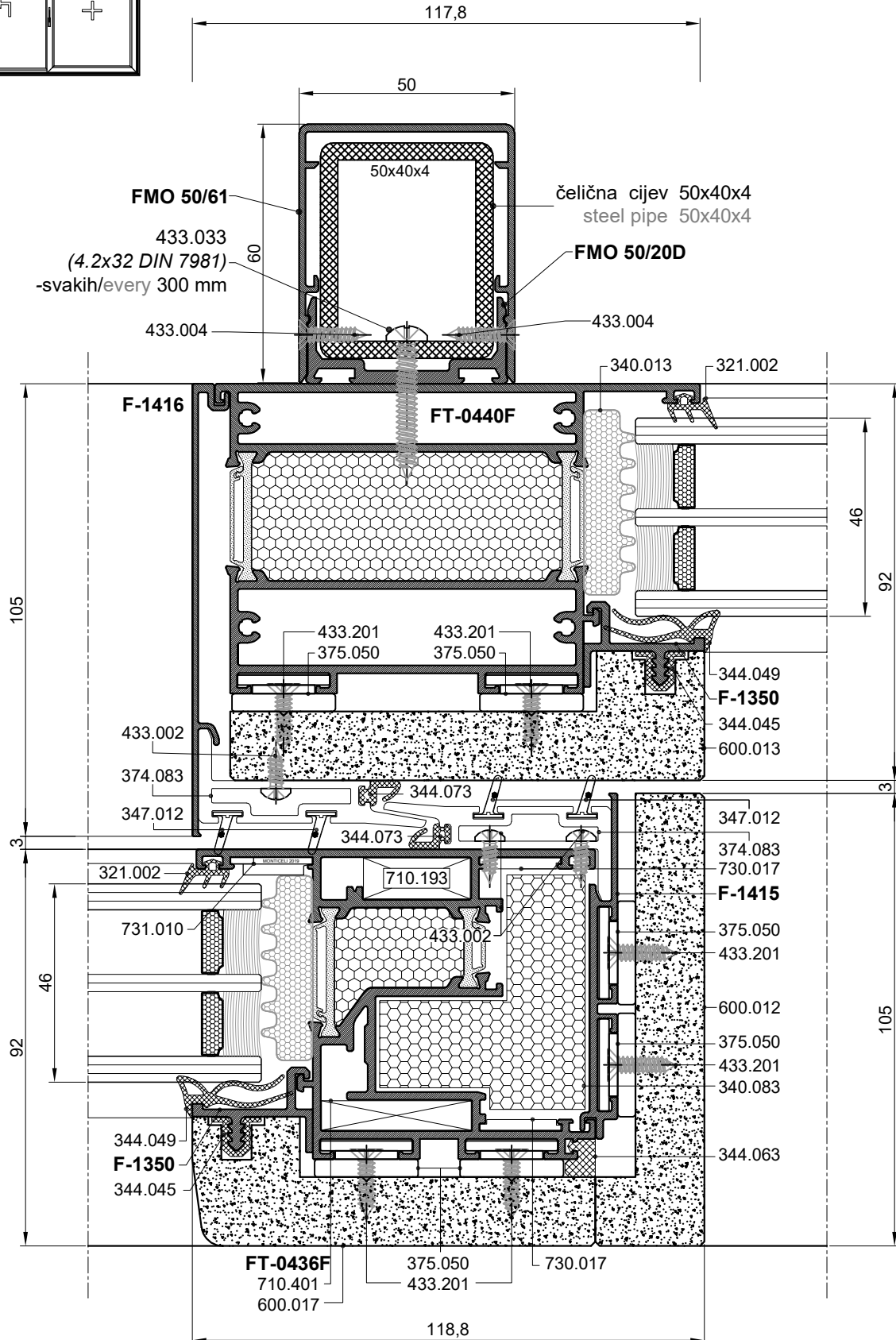
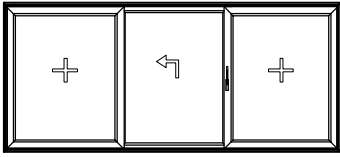
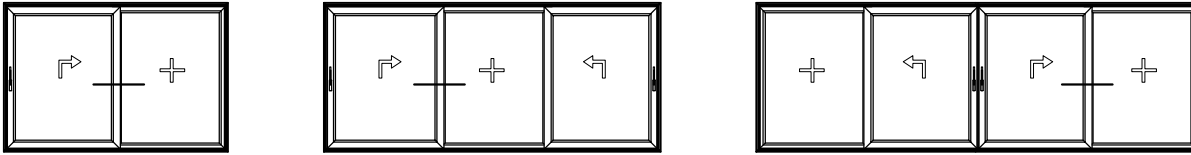

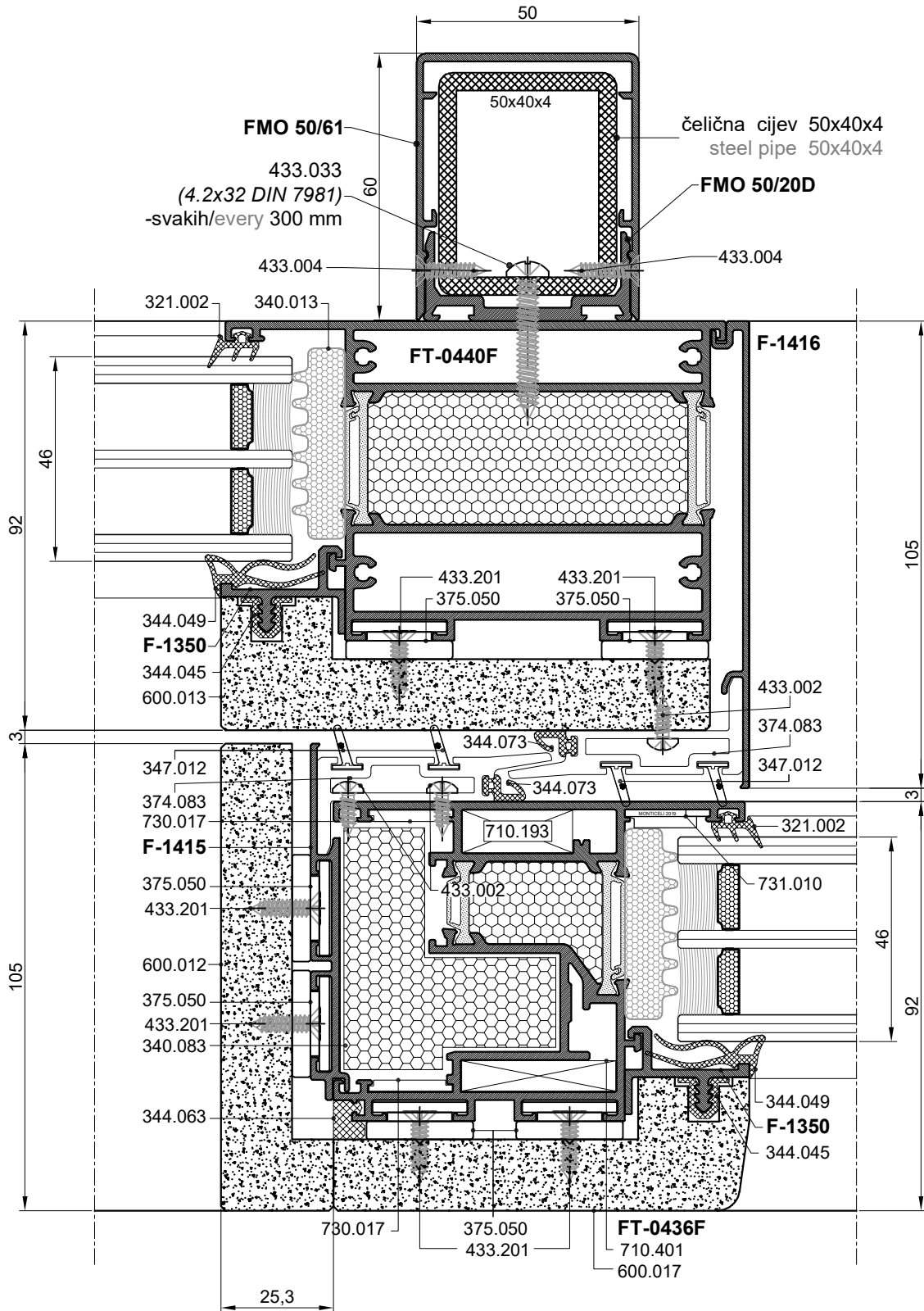
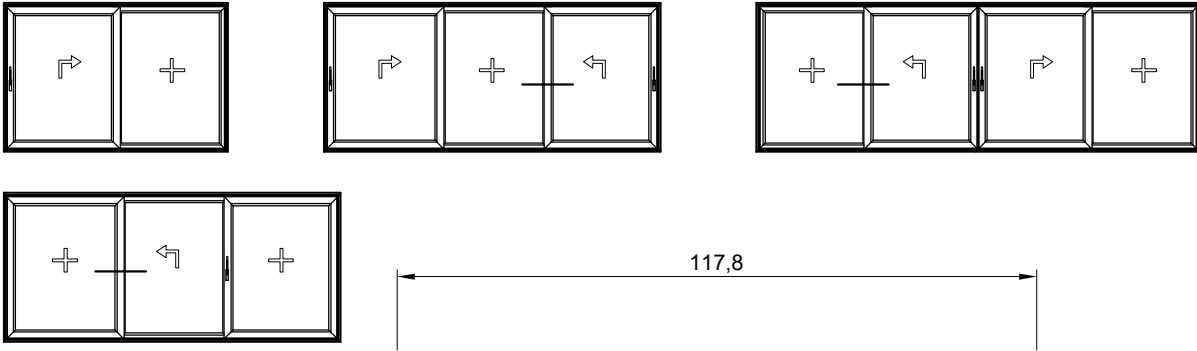

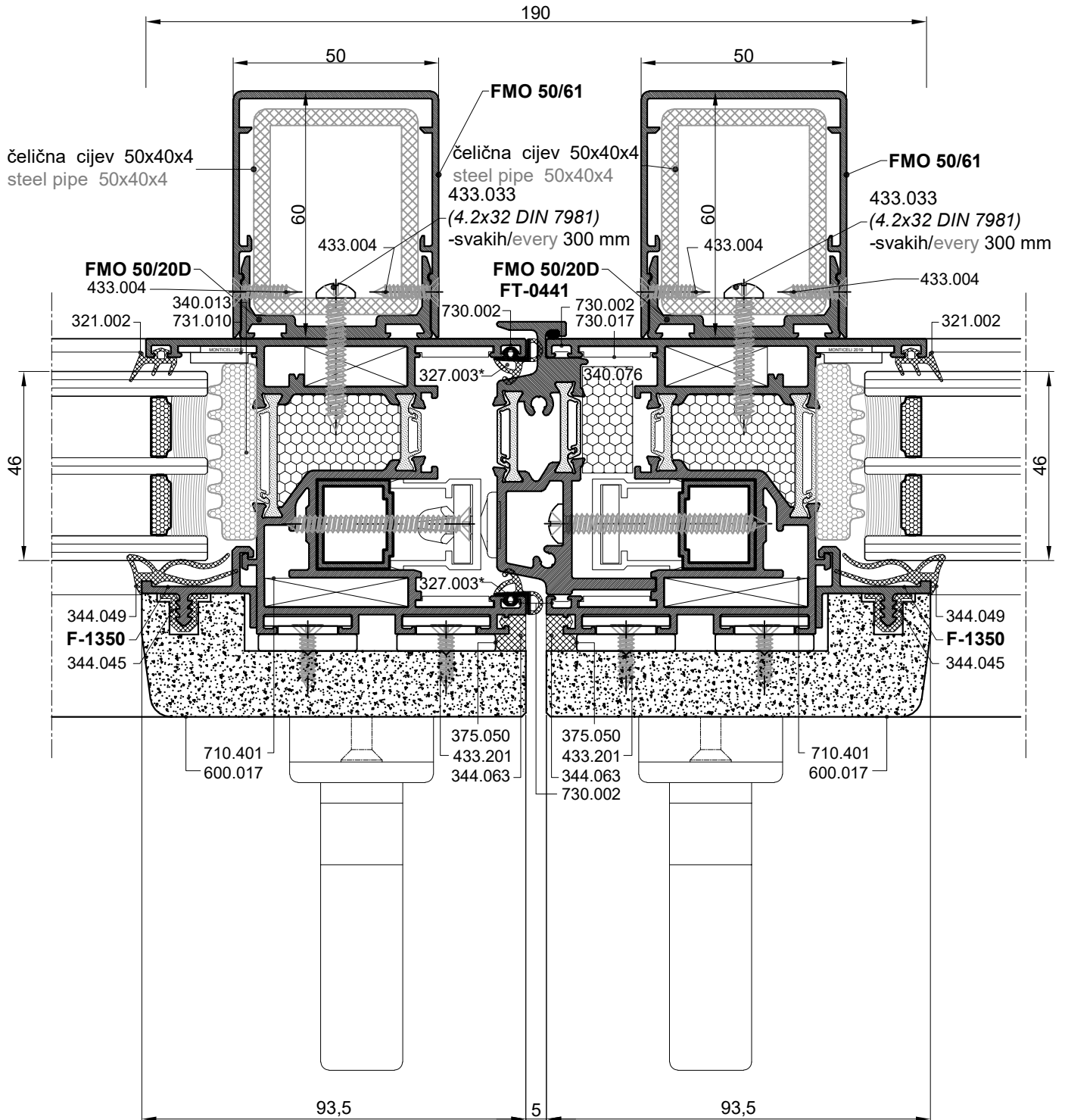
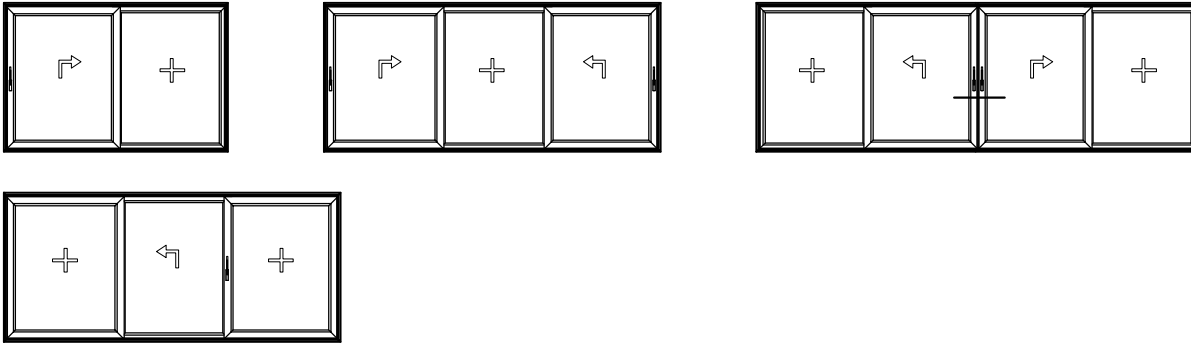

*Moguće koristiti brtvu 344.108

*The possibility of using a gasket 344.108

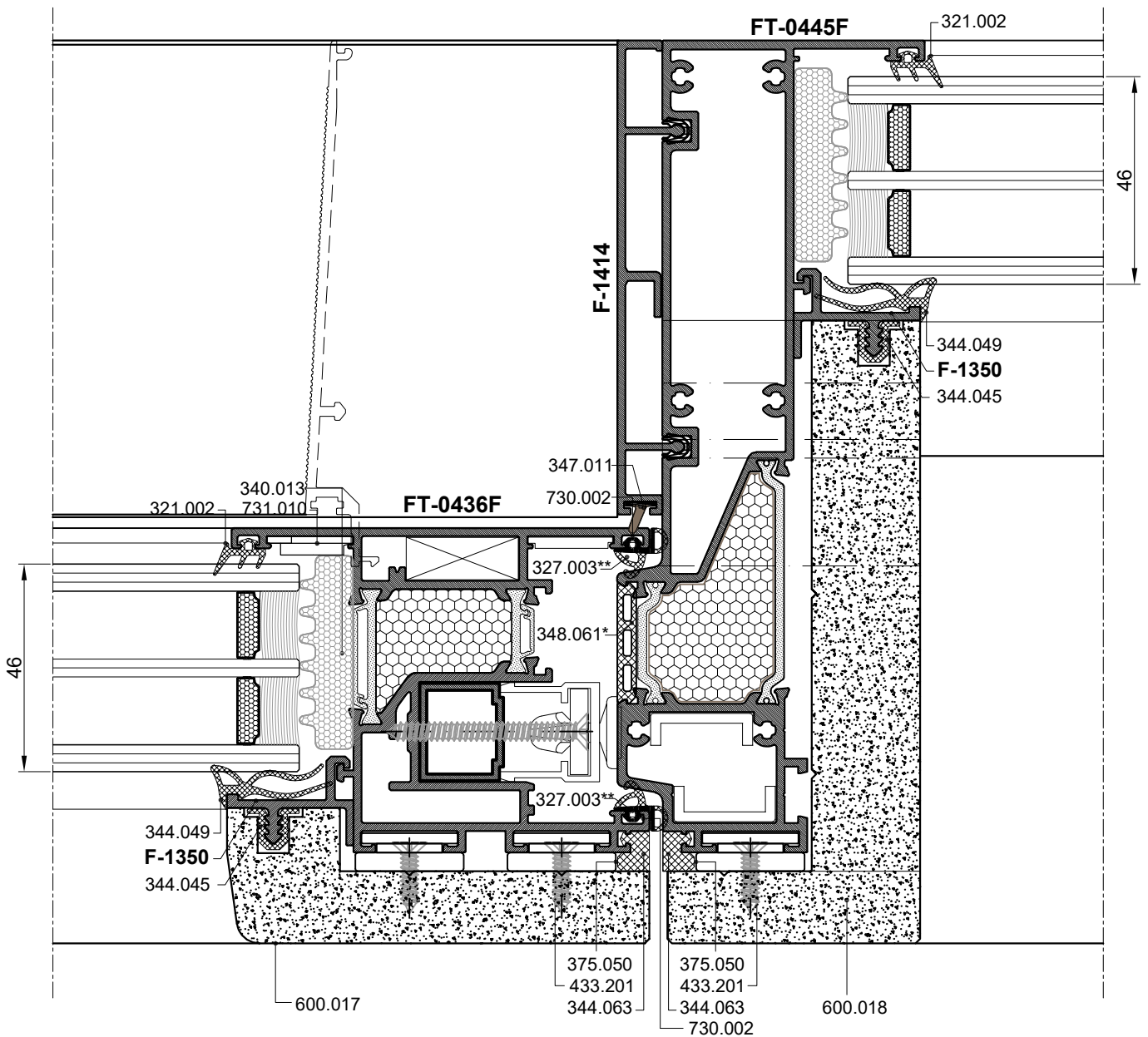
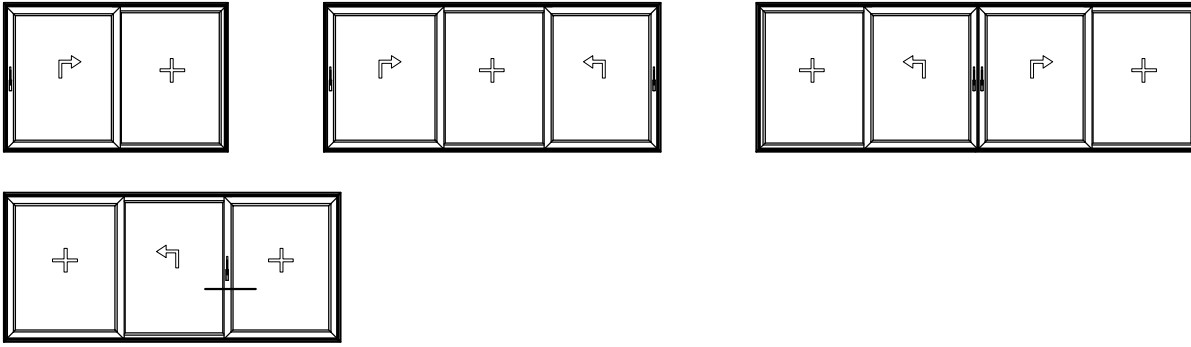

*Moguće koristiti brtvu 344.061

**Moguće koristiti brtvu 344.108

*The possibility of using a gasket 344.061

**The possibility of using a gasket 344.108

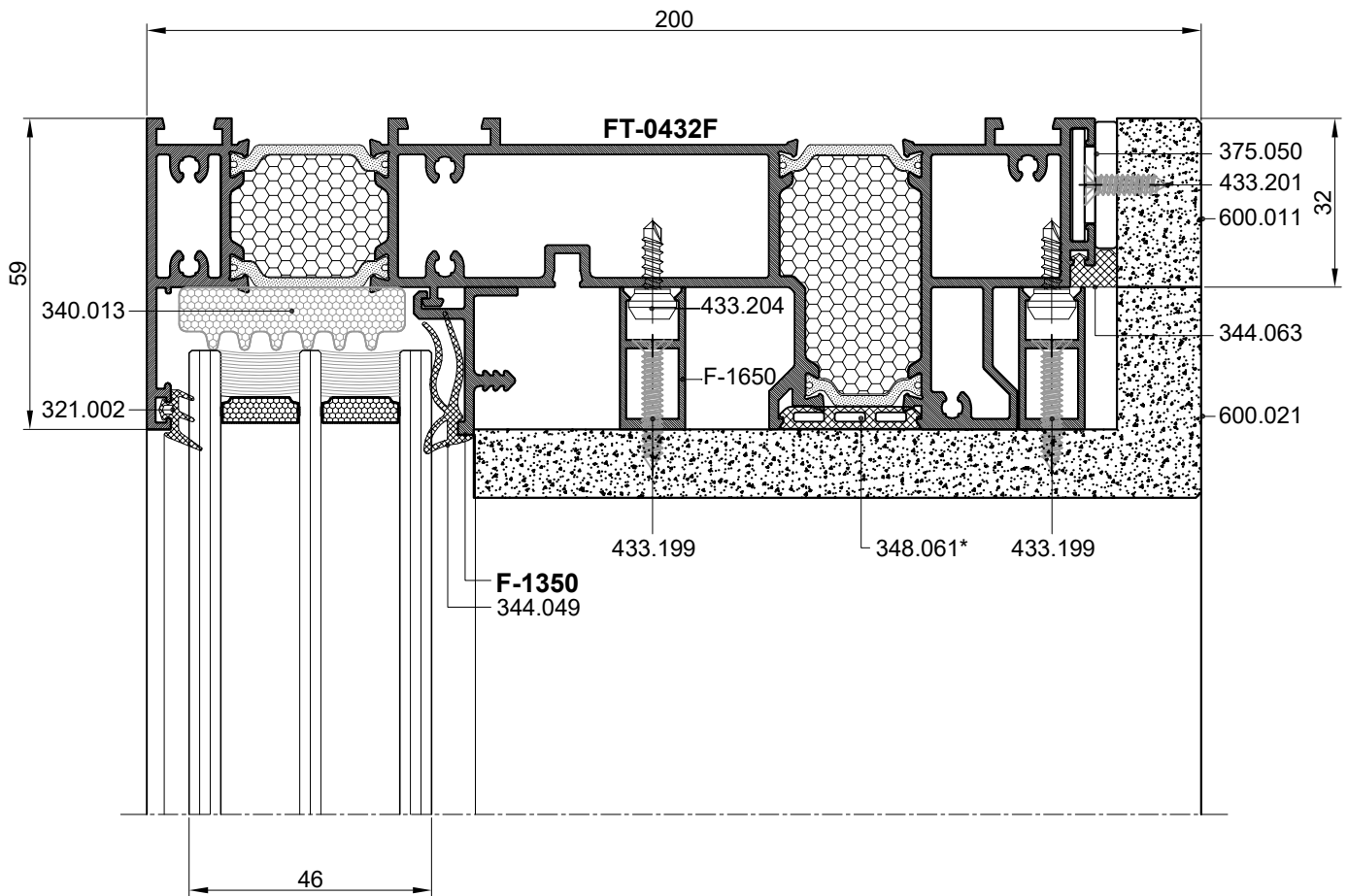
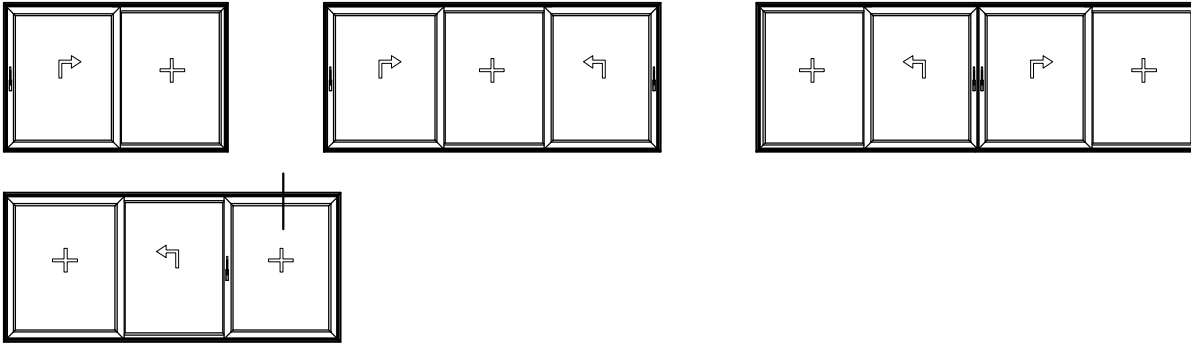

*Moguće koristiti brtvu 344.061

*The possibility of using a gasket 344.061

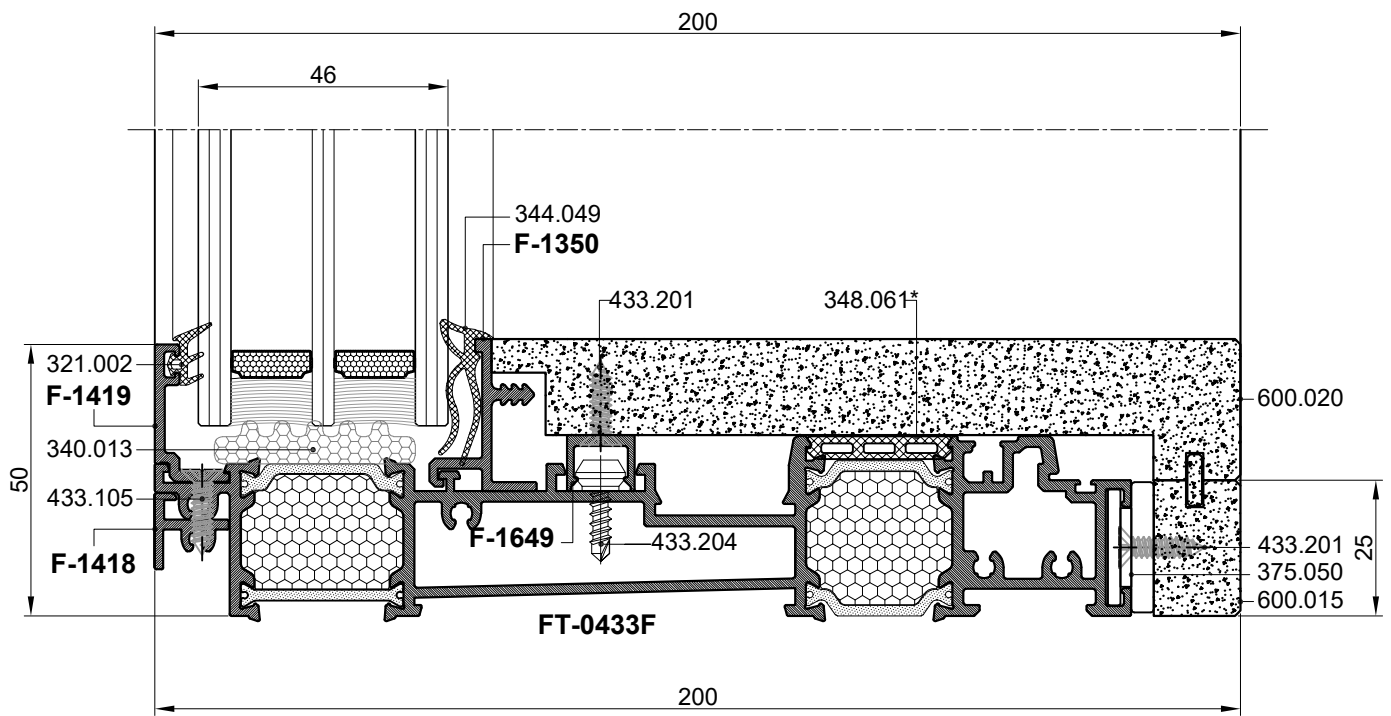
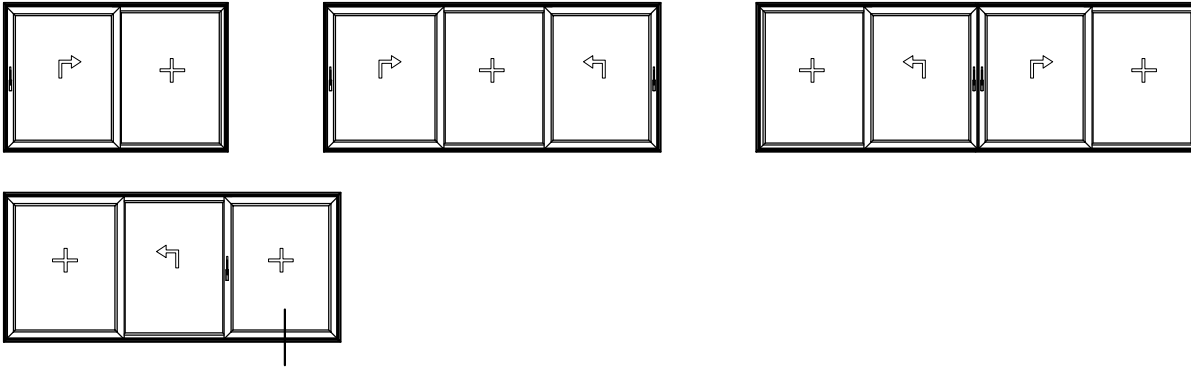

*Moguće koristiti brtvu 344.061

*The possibility of using a gasket 344.061

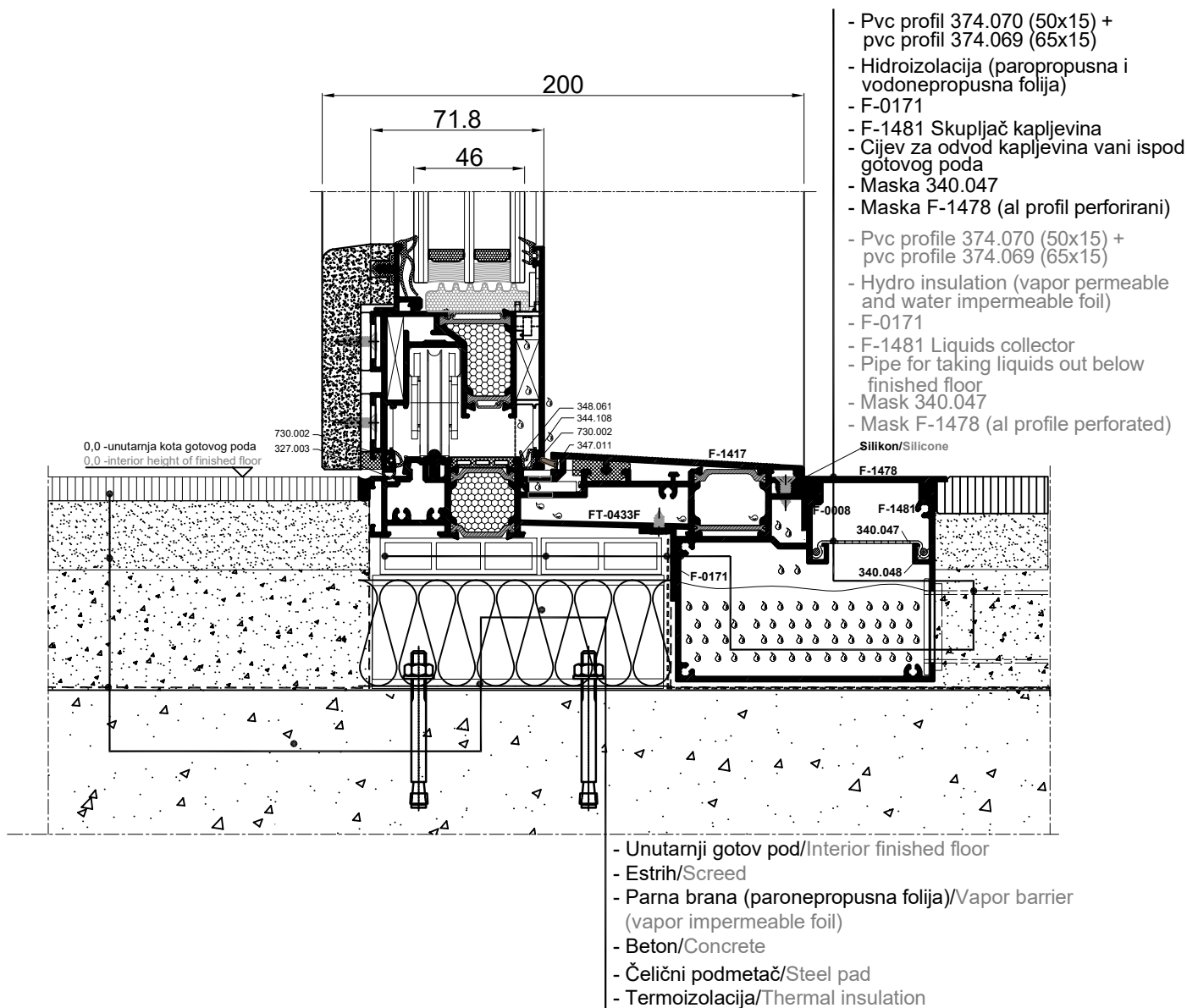
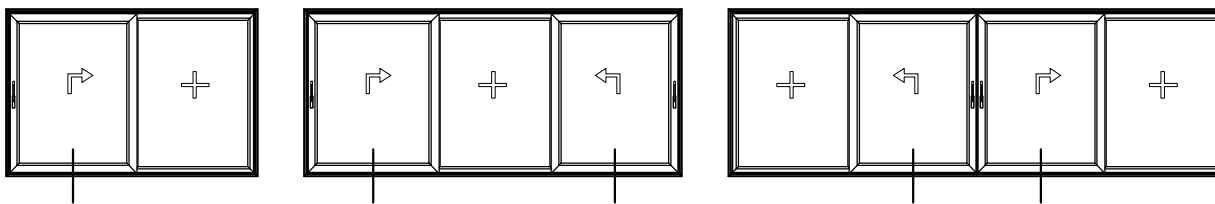

Napomena:

- Montaža vrata sa dodatnim profilom za sakupljanje kapljevina
- Visina praga u odnosu na kotu gotova poda 10 mm.

Remark:

- Door montage with additional profile for liquid collecting
- Threshold height with reference to height of finished floor 10 mm

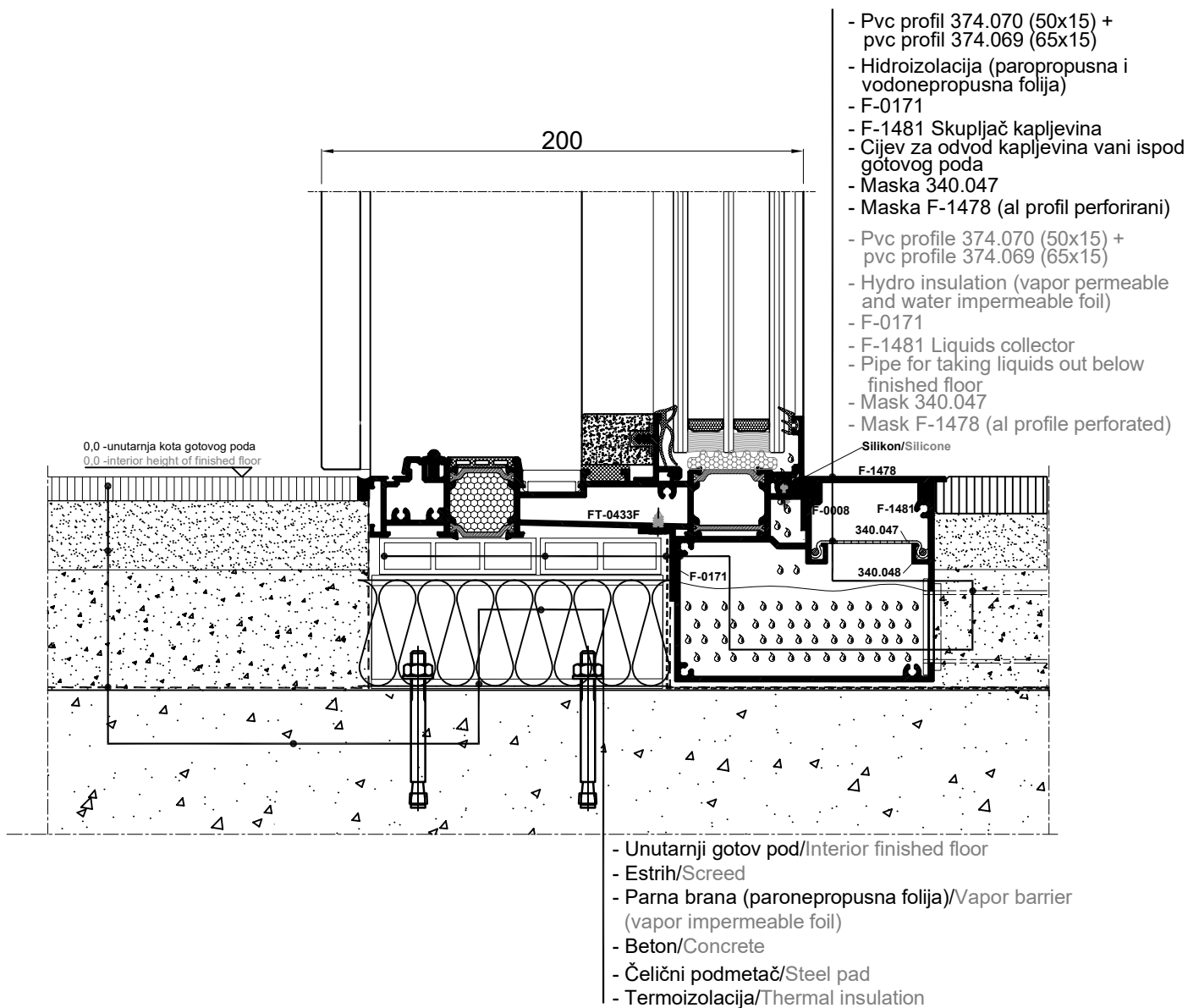
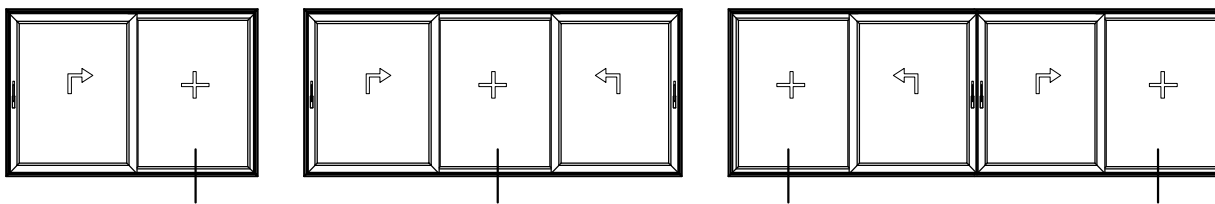

Napomena:

- Montaža vrata sa dodatnim profilom za sakupljanje kapljevina
- Visina praga u odnosu na kotu gotova poda 10 mm.

Remark:

- Door montage with additional profile for liquid collecting
- Threshold height with reference to height of finished floor 10 mm

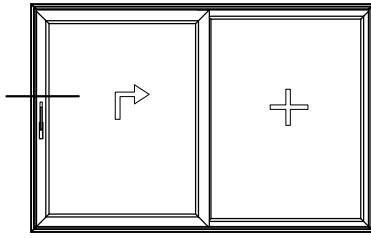

- vanjska završna obrada
- vanjska toplinska izolacija
- paropropusna i vodonepropusna folija (hidroizolacija)
- toplinska izolacija
- paro i vodonepropusna folija (parna brana)
- unutarnja završna obrada
- exterior finishing
- exterior thermal insulation
- vapor permeable and water impermeable foil (hydro insulation)
- thermal insulation
- vapor and water impermeable foil (vapor barrier)
- interior finishing

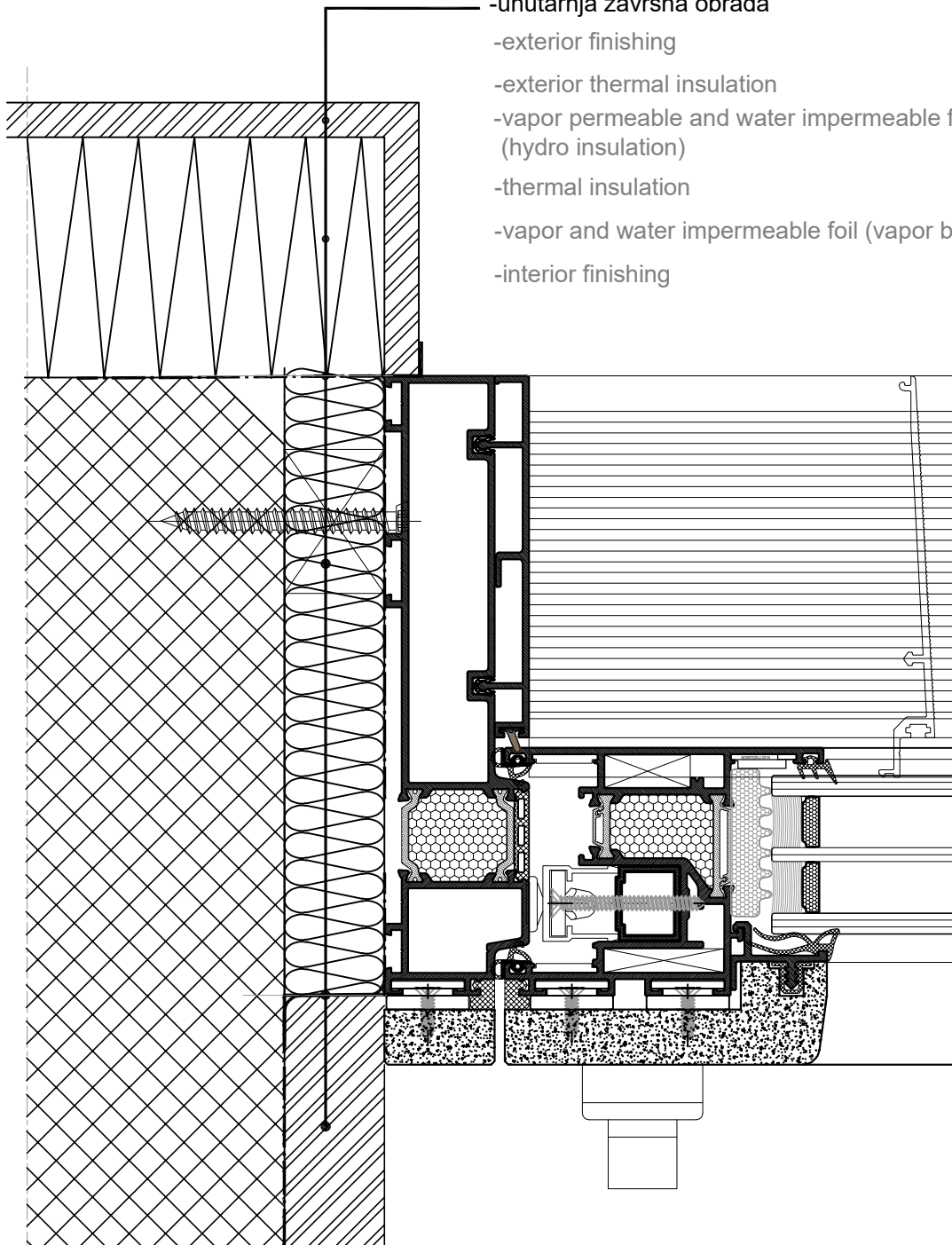

Prikaz odvodnje vode sa dodatnim profilom za sakupljanje kapljevina za klizne sistema (niske pragove do 10 mm):

Display of drainage system with additional profile for liquid collecting for sliding systems (low thresholds up to 10 mm):

1 - klizni sistemi (ugradnja sa visinom praga u odnosu na gotov pod do 13 mm)

1 - sliding systems (installation with threshold height in reference to the finished floor up to 13 mm)

2 - terasa

2 - terrace

3 - cijev za odvod kapljevina iz kliznog sistema preko dodatnog profila za sakupljanje kroz estrih (preko terase) u svodnu cijev za oborinske vode

3 - pipe for drainage from sliding system with additional profile for liquids collecting through screed (over terrace) into drainpipe

4 - svodne cijevi za oborinske vode

4 - drainpipe

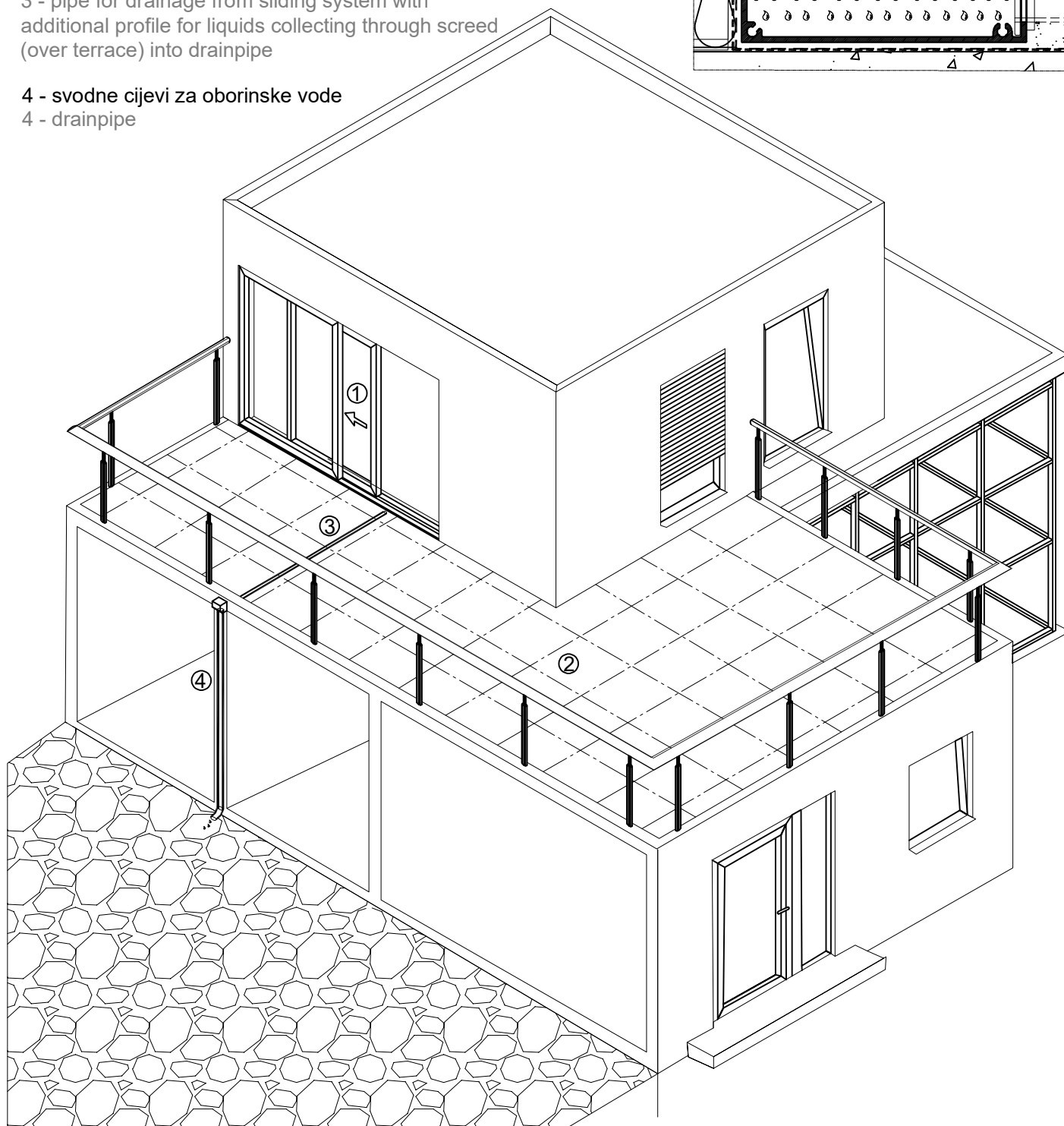
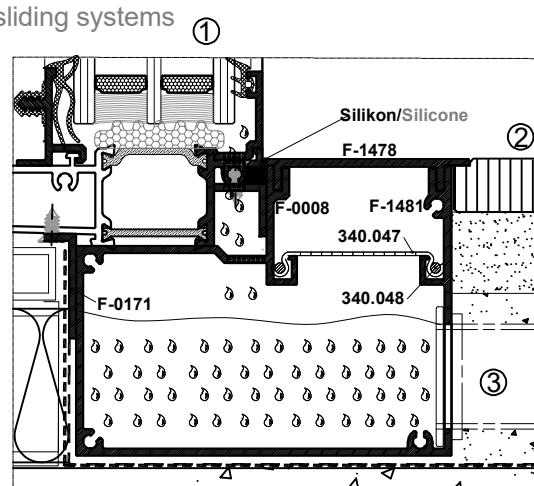

Obrada i montaža

Processing and montage

UPREŠAVANJE STJENKE PROFILA U KUTNU SPOJNICU CRIMPING PROFILE WALL IN CORNER BRACKET

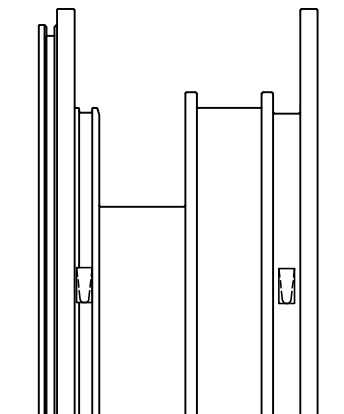
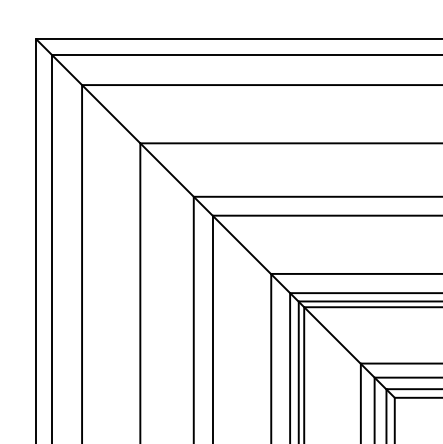
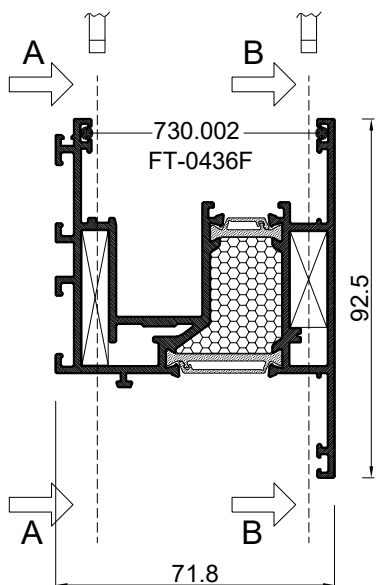

Spajanje kutnikom 710.193
uprešavanjem stijenke profila
prema kutniku
Corn. brac. connection 710.193
aluminium profile corner
crimping

Spajanje kutnikom 710.401
uprešavanjem stijenke profila
prema kutniku
Corn. brac. connection 710.401
aluminium profile corner
crimping

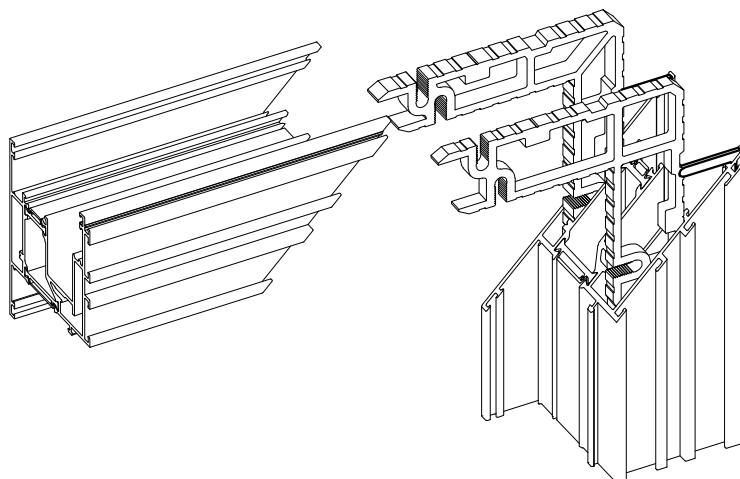
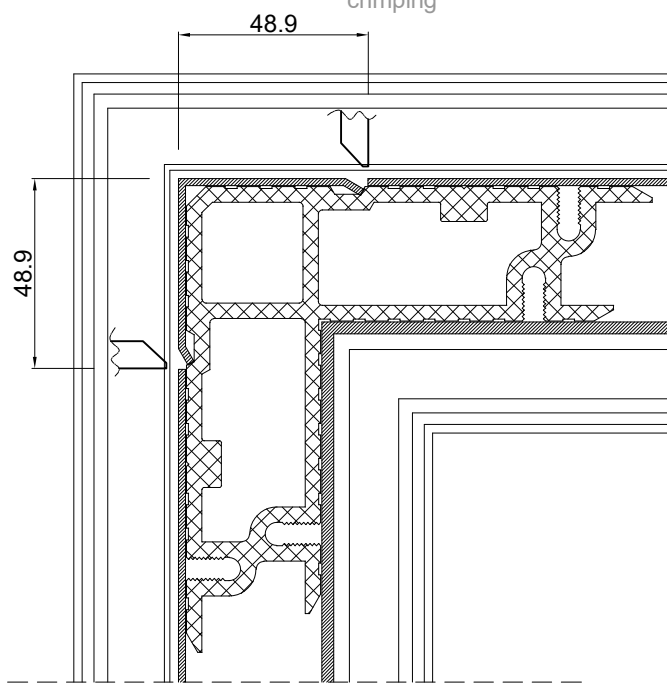
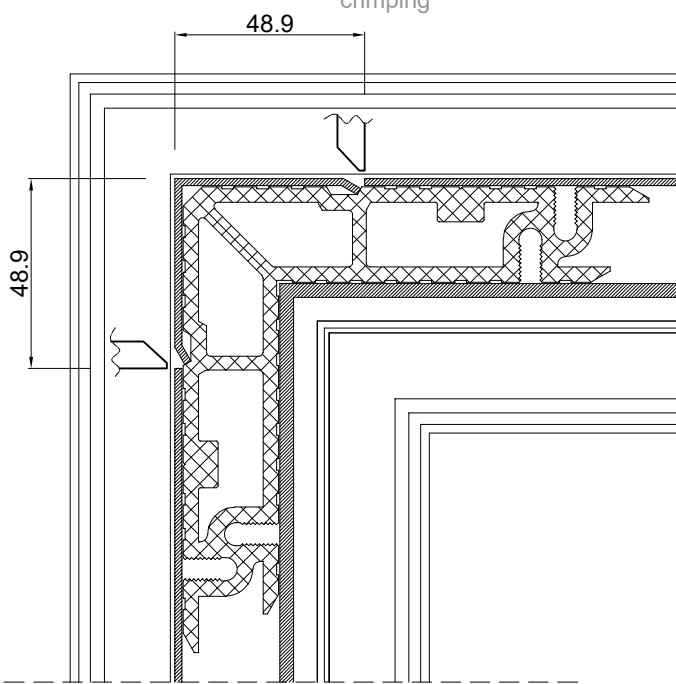

Vanjski spoj krila pomoću kutnika 730.017 Outside connection of sash with corner bracket 730.017

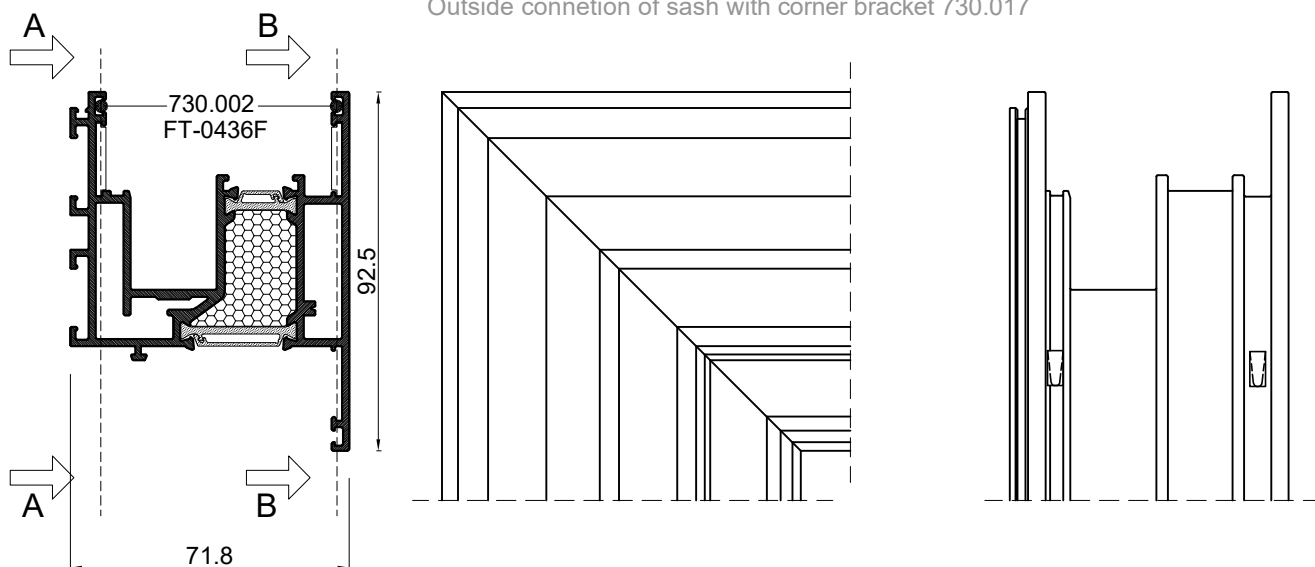

Spajanje kutnikom 730.017 Connecting with cor. brac. 730.017

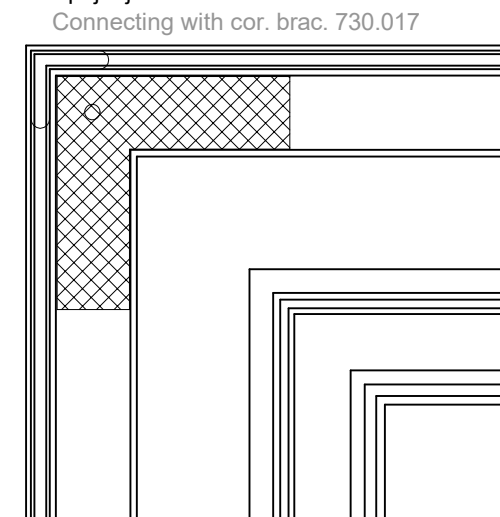

Spajanje kutnikom 730.017 Connecting with cor. brac. 730.017

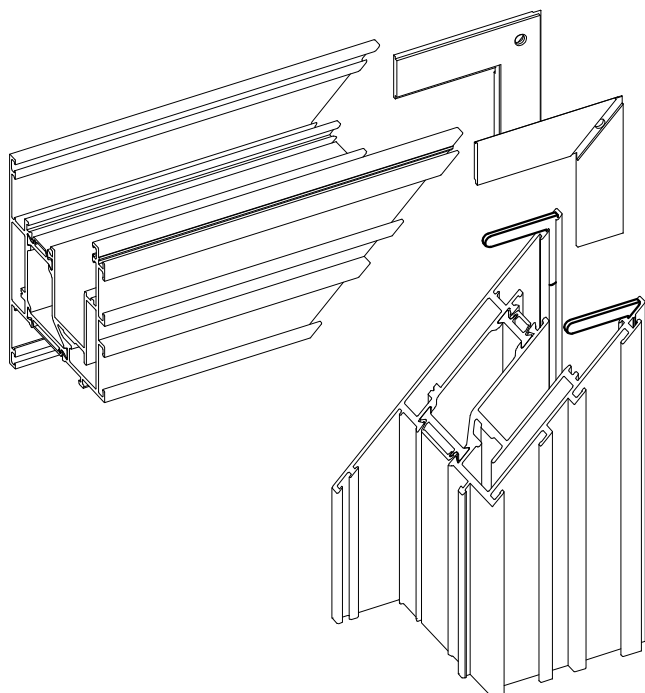
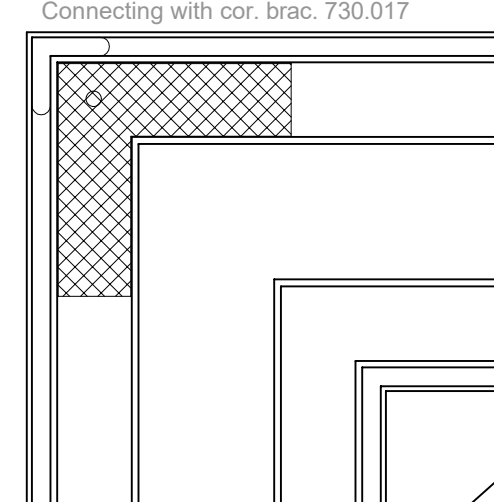

Ubrizgavanje dvokomponentnog ljepljiva
kroz PVC umetak
(npr. Wurth 2K-PUR - 0892 135)
Injection of two component glue
through PVC insert
(e.g. Wurth 2K-PUR - 0892 135)

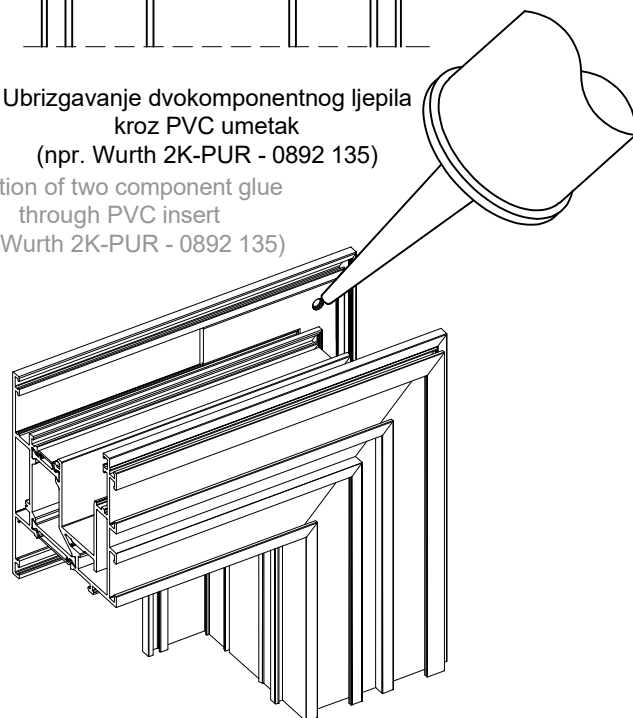

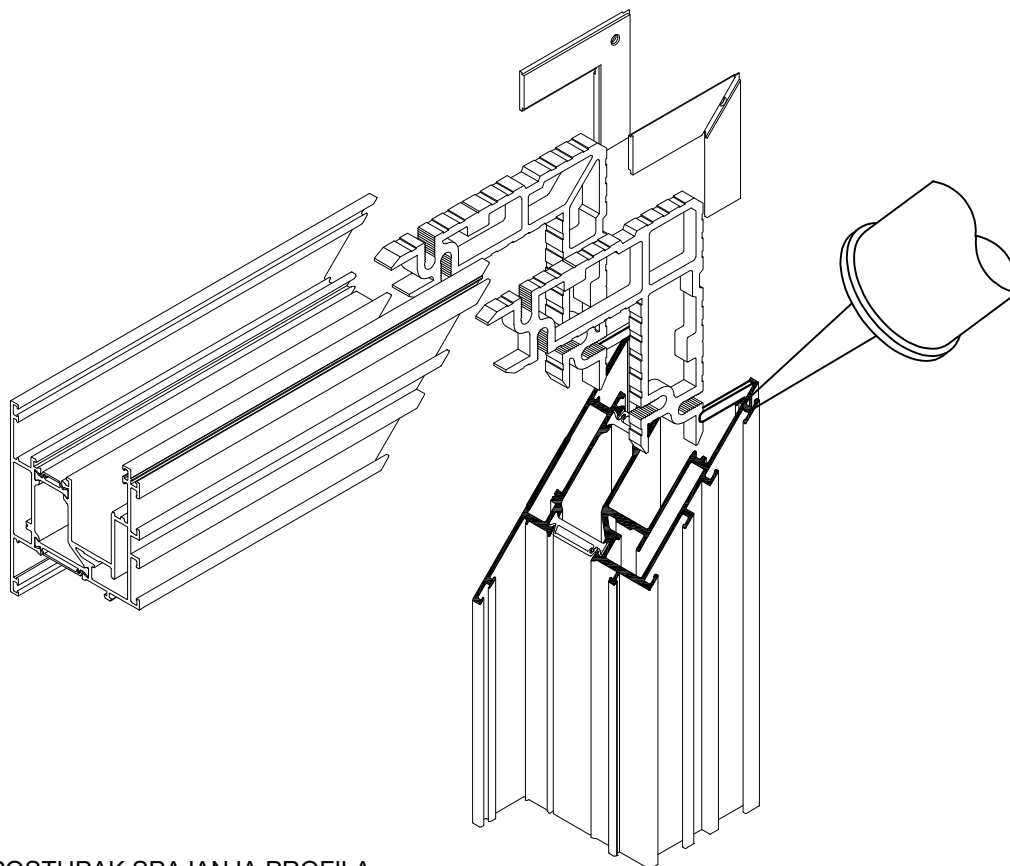
SPAJANJE PROFILA KUTNIM SPOJNICAMA
PROFILE CONNECTION WITH CORNER BRACKETSPOSTUPAK SPAJANJA PROFILA:
PROFILE CONNECTION PROCEDURE:

1. Površine koje se spajaju-rezove očistiti i odmastiti prikladnim sredstvom /npr.Sika Remover 208; Wurth-kat.br.:892 130 30/.
1. Surfaces that are connecting - clean and degreased the cut with suitable products /e.g. Sika Remover 208; Wurth-kat. No.:892 130 30/.
2. Premazati površine koje se spajaju ljepilom za metal /npr. Sika Force 7851; Wurth-kat.br.:892 130 010/.
2. Smear surfaces that are connecting with metal glue /e.g. Sika Force 7851; Wurth-kat.No.:892 130 010/.
- 2.1. Ljepilo za metal ušpricati u komoru za kutnik - po opsegu komore
- 2.1. Spurt metal glue into chambers for the corner bracket (on chamber circumference)
3. Profile s kutnikom izravnati i spojiti
3. Level profiles with corner brackets and connect
4. Dio ljepila koji iscuri između rezova očistiti sredstvom za čišćenje i odmašćivanje /npr.Sika Remover 208; Wurth-kat.br.:892 130 30/.
4. Leaking glue that comes from the joints remove with cleaning and degrease product /e.g.Sika Remover 208; Wurth-kat.No.:892 130 30/.

NAPOMENA:
REMARK:

Ovaj postupak spajanja profila primjenjiv je za sve Feal-ove kutnike i njima odgovarajuće komore:

This profile connection procedure is applicable for all Feal corner brackets and their appropriate chambers.

Lijepljenjem rezova i kutnika ljepilima za metal osigurava se potrebna zrako- i vodonepropusnosti spoja kao i dodatna mehanička čvrstoća spoja.

Gluing cuts and corners with metal glues provides necessary air and water tightness of the joint and additional mechanical properties.

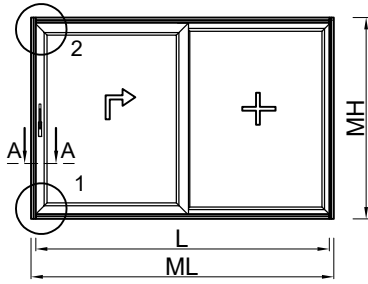

presjek A-A M 1:1
cross section A-A M 1:1

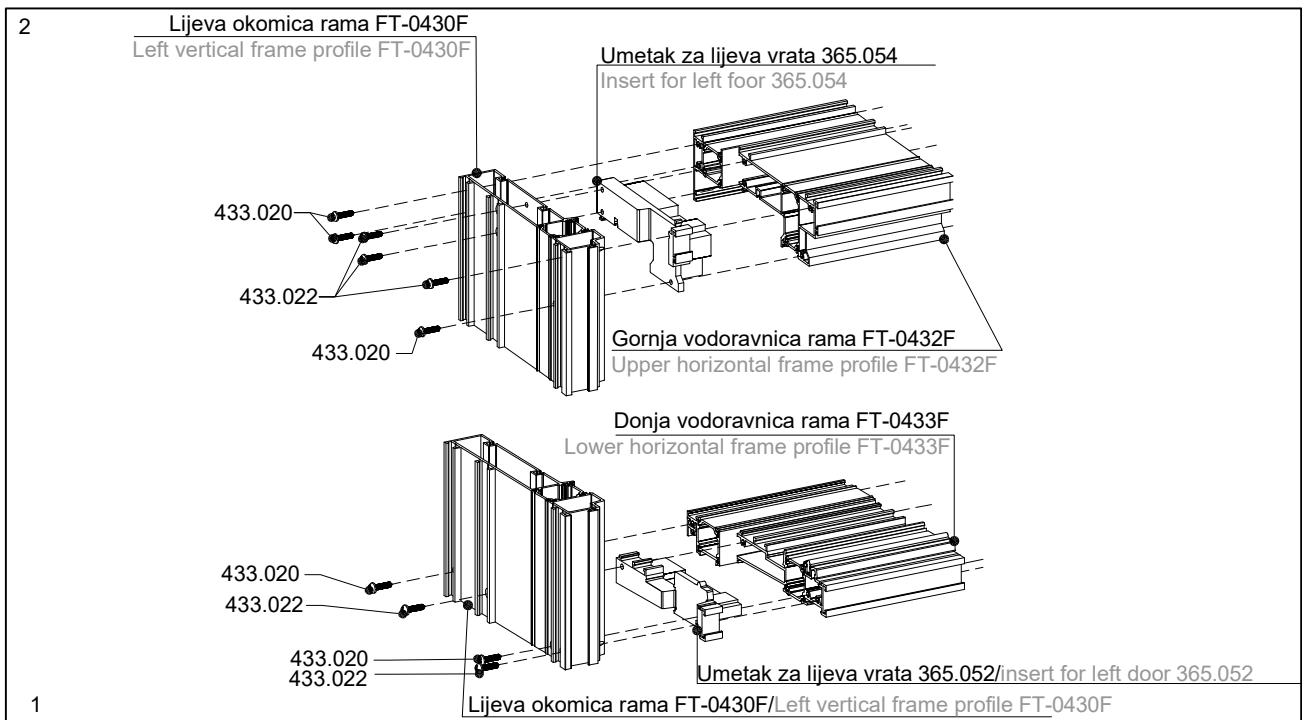
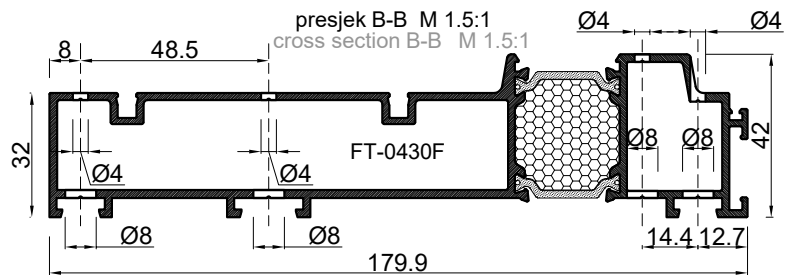
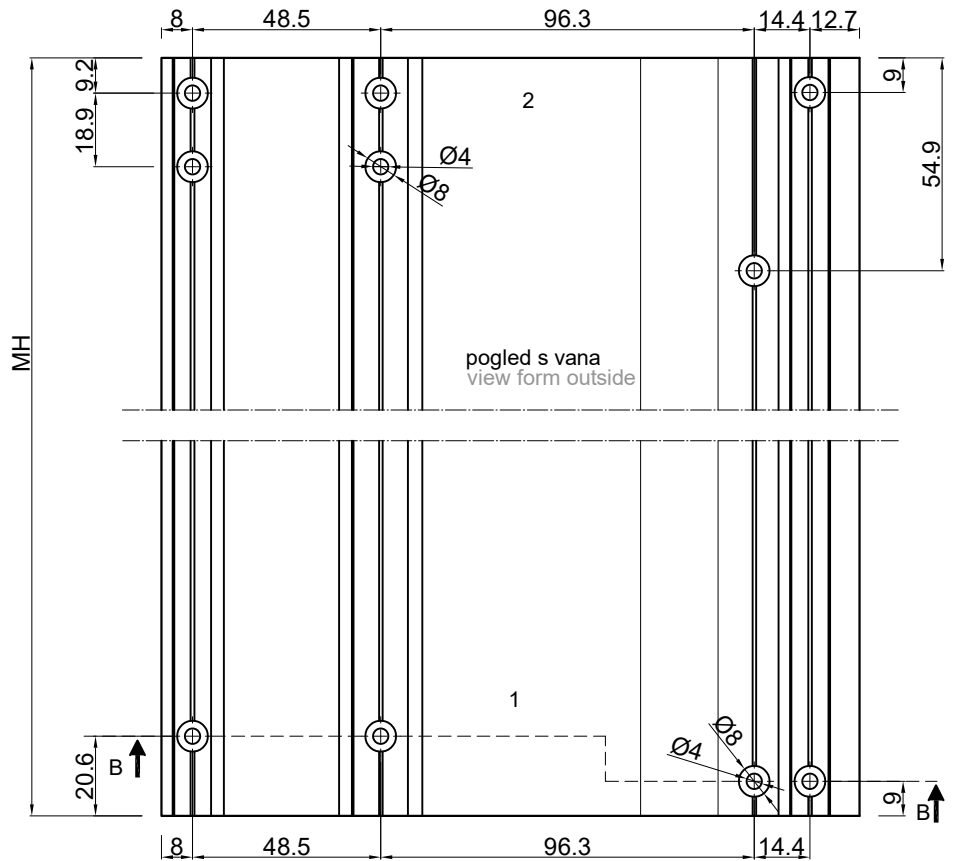
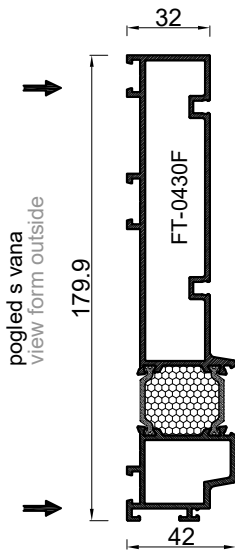

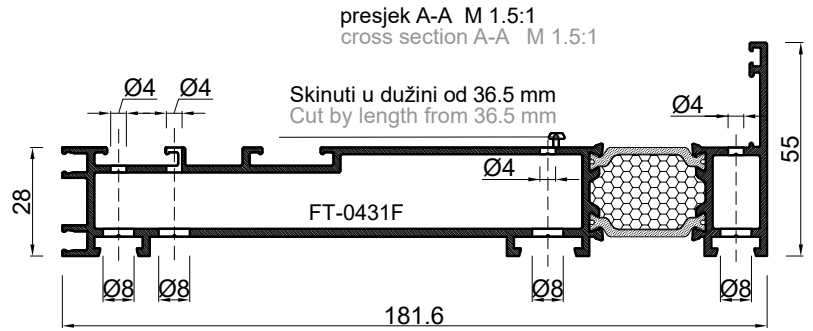
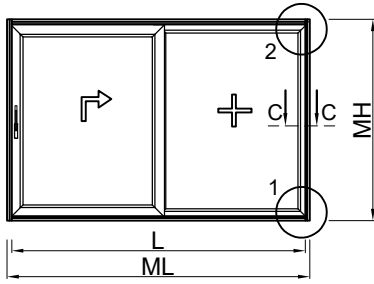

presjek C-C M 1:1
cross section C-C M 1:1

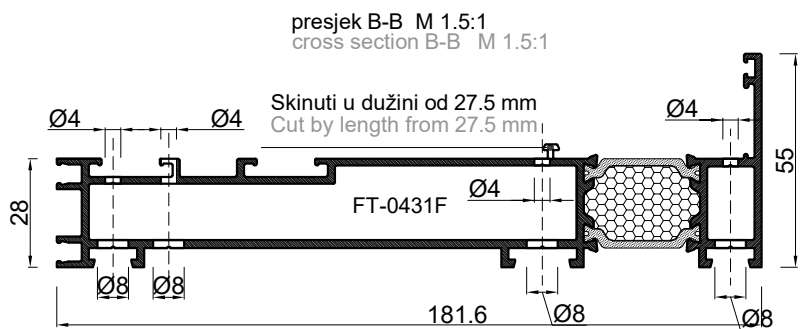
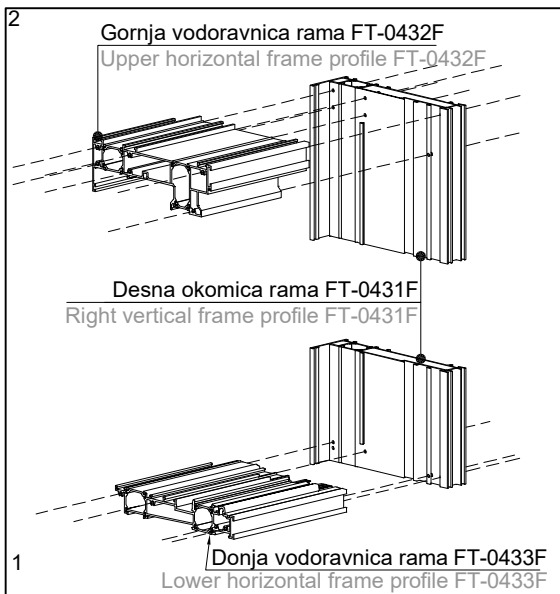
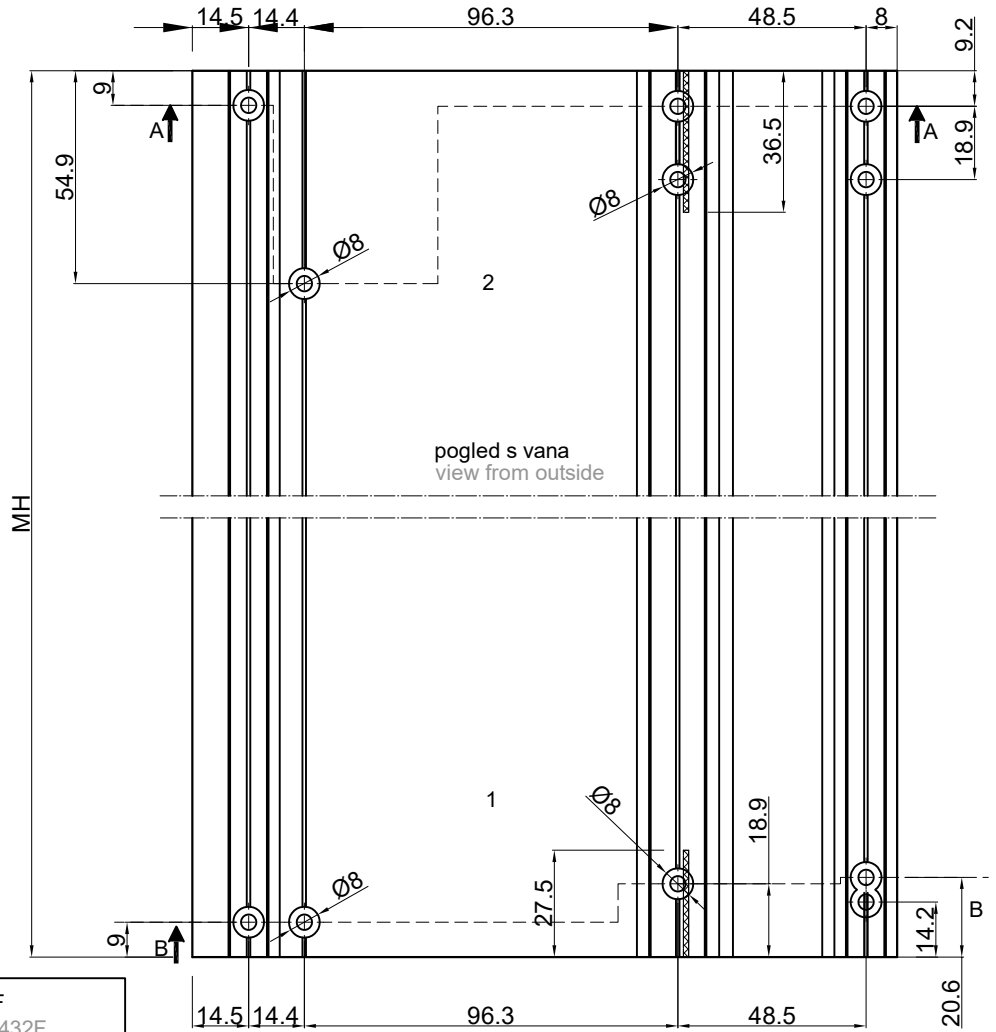
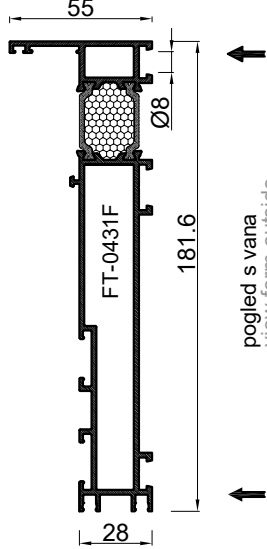

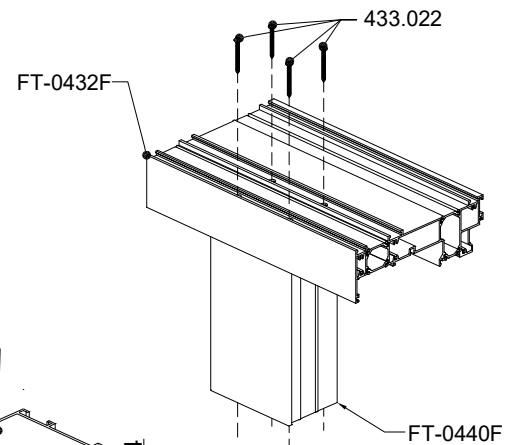
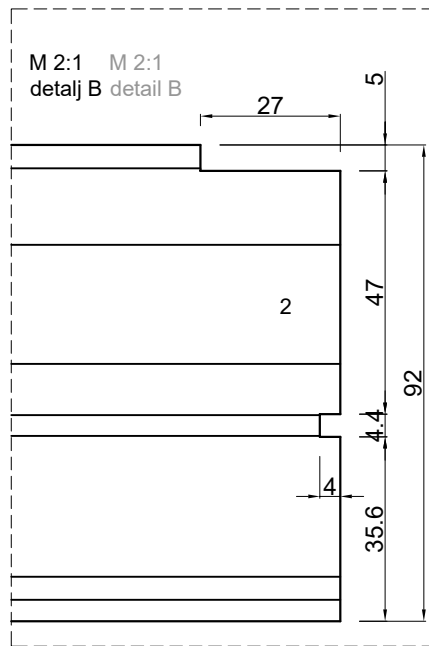
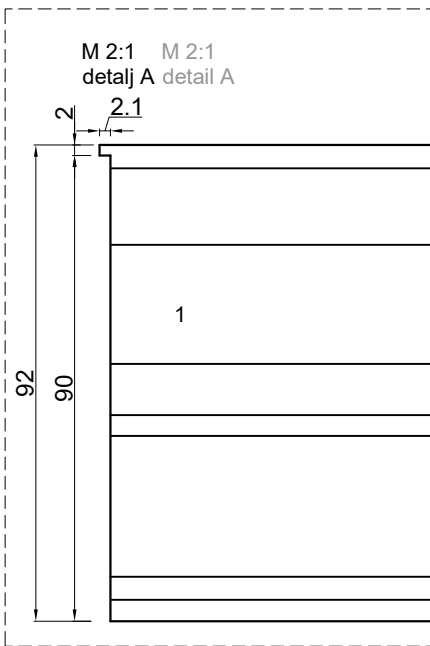
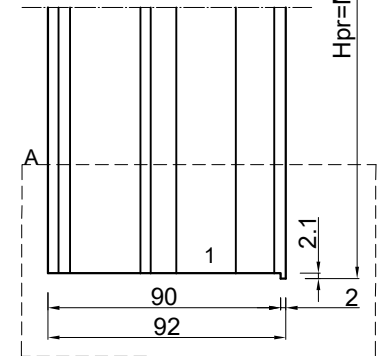
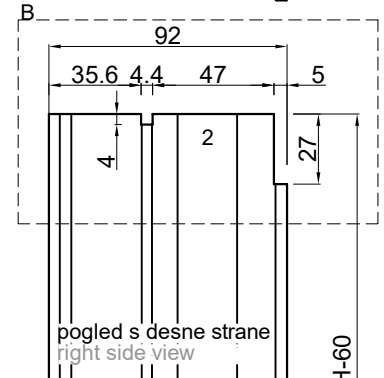
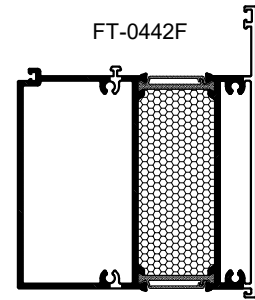
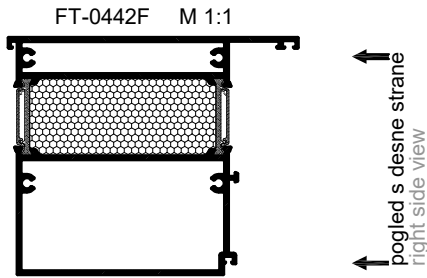
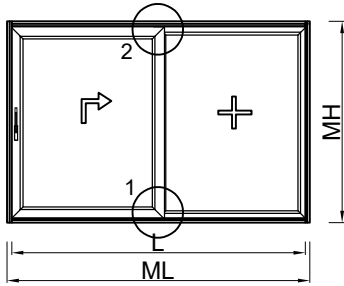

Profil FT-0442F obraditi na sljedeći način:
Profile FT-0442F process like:

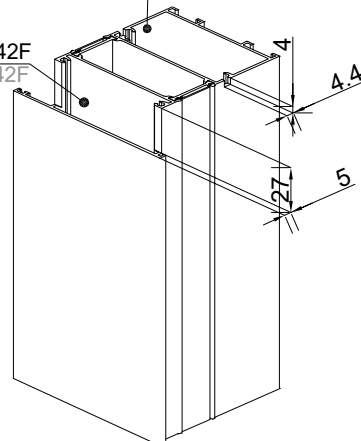
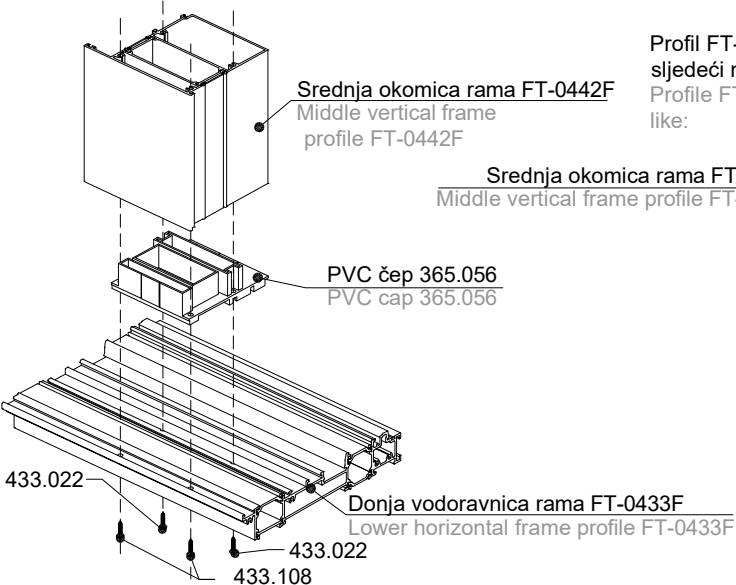

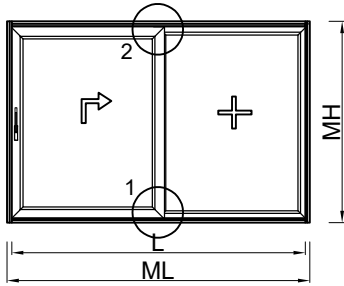

FT-0440F M 1:1

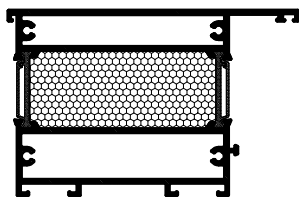

↑ pogled s desne strane
↑ right side view

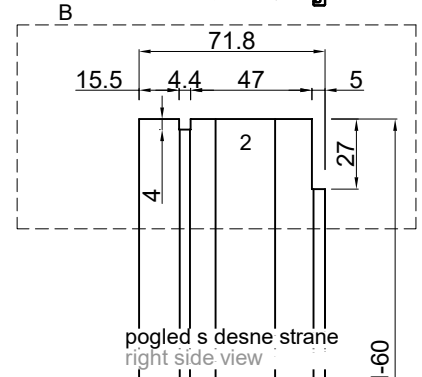
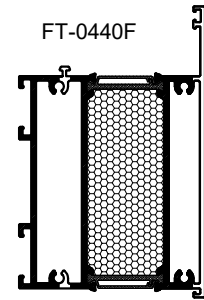

↑ pogled s desne strane
↑ right side view

Hpr=MH-60

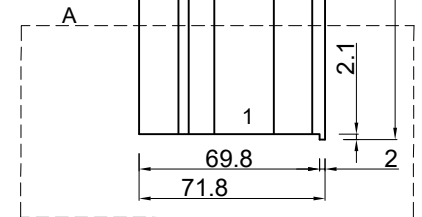

M 2:1 M 2:1
detalj A detalj A

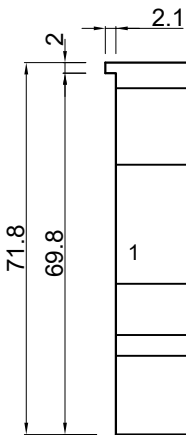

M 2:1 M 2:1
detalj B detalj B

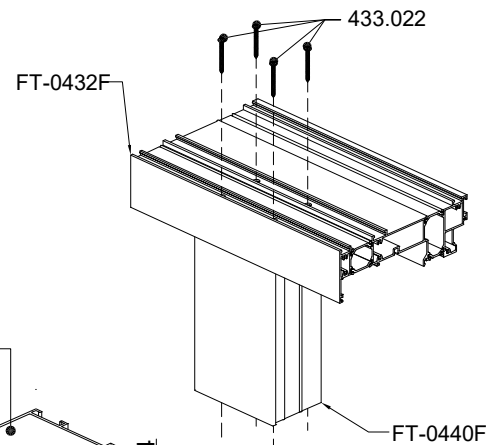
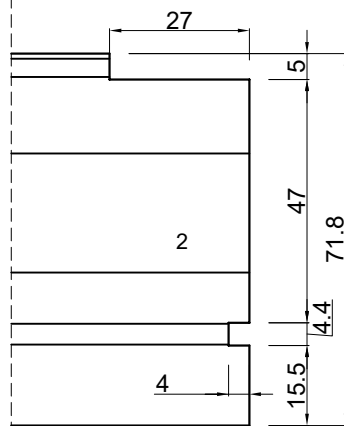

Profil FT-0440F obraditi na
sljedeći način:
Profile FT-0440F process
like:

Srednja okomica rama FT-0440F
Middle vertical frame
profile FT-0440F

Srednja okomica rama FT-0440F
Middle horizontal frame
profile FT-0440F

PVC čep 365.056
PVC cap 365.056

Donja vodoravnica rama FT-0433F
Lower horizontal frame profile FT-0433F

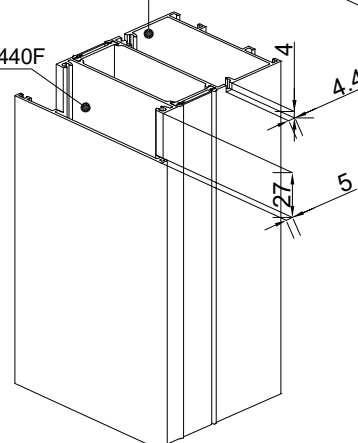
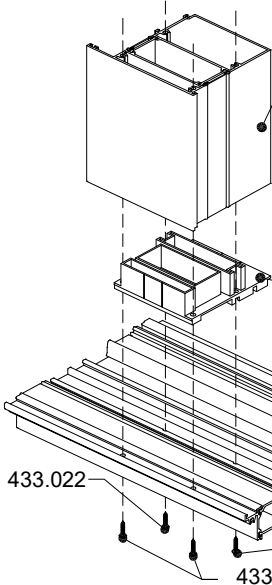

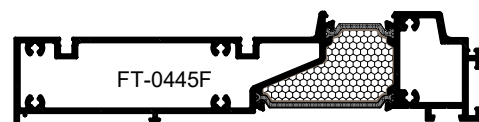
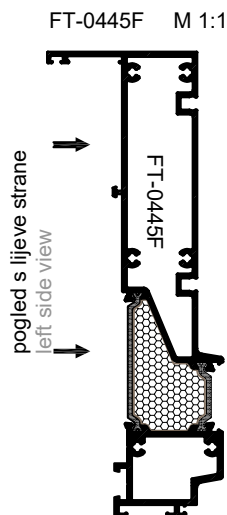
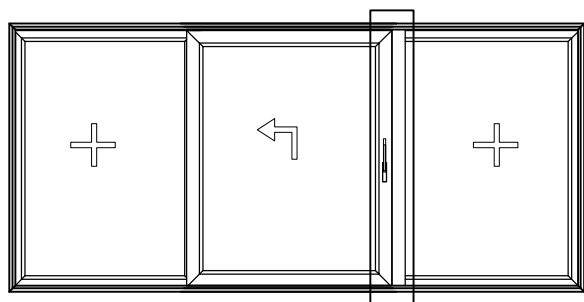

- Obrada profila prečke FT-0445F zapilavanjem.
- Processing mullion profile FT-0445F with cutting.

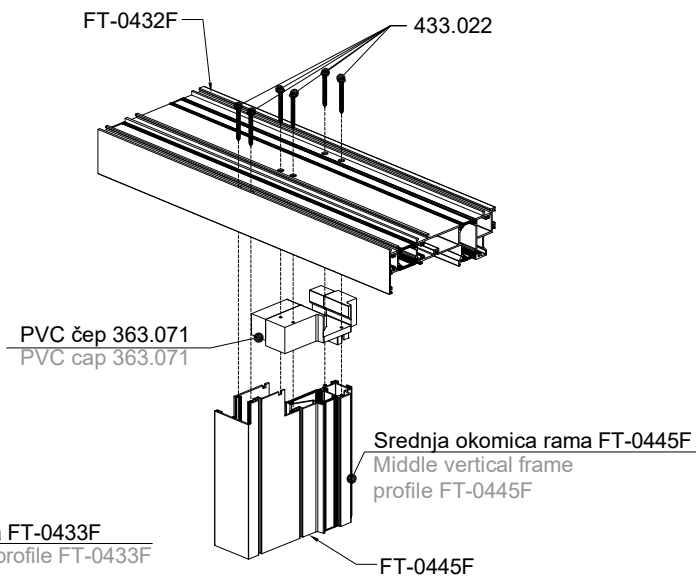
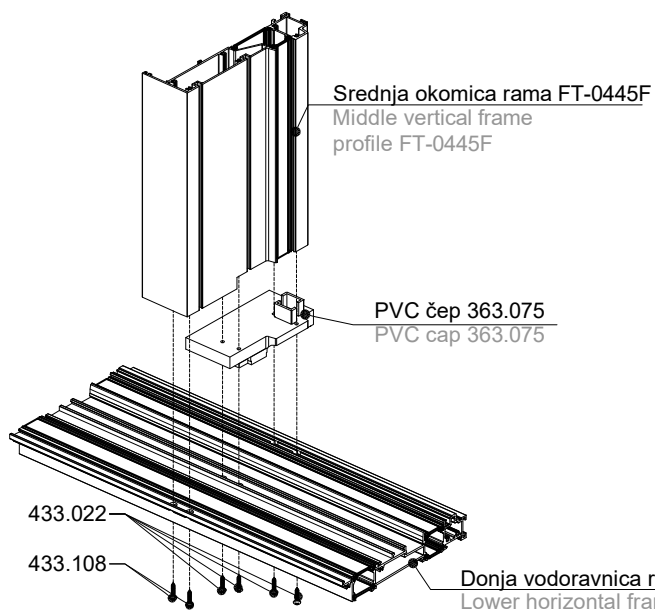
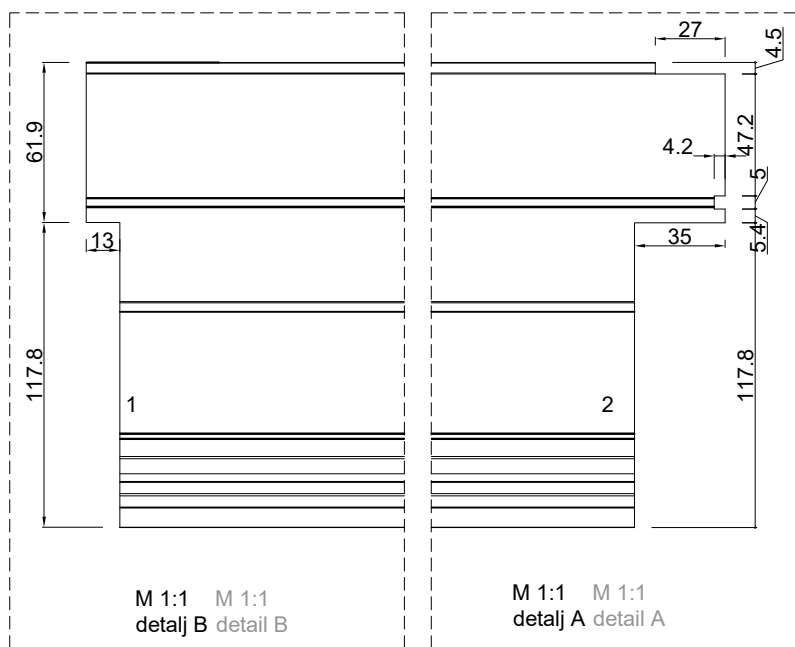
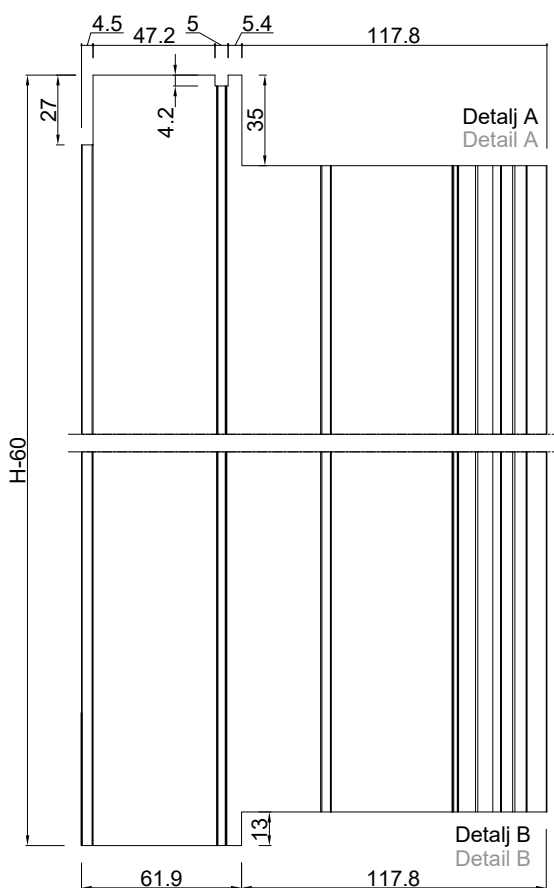

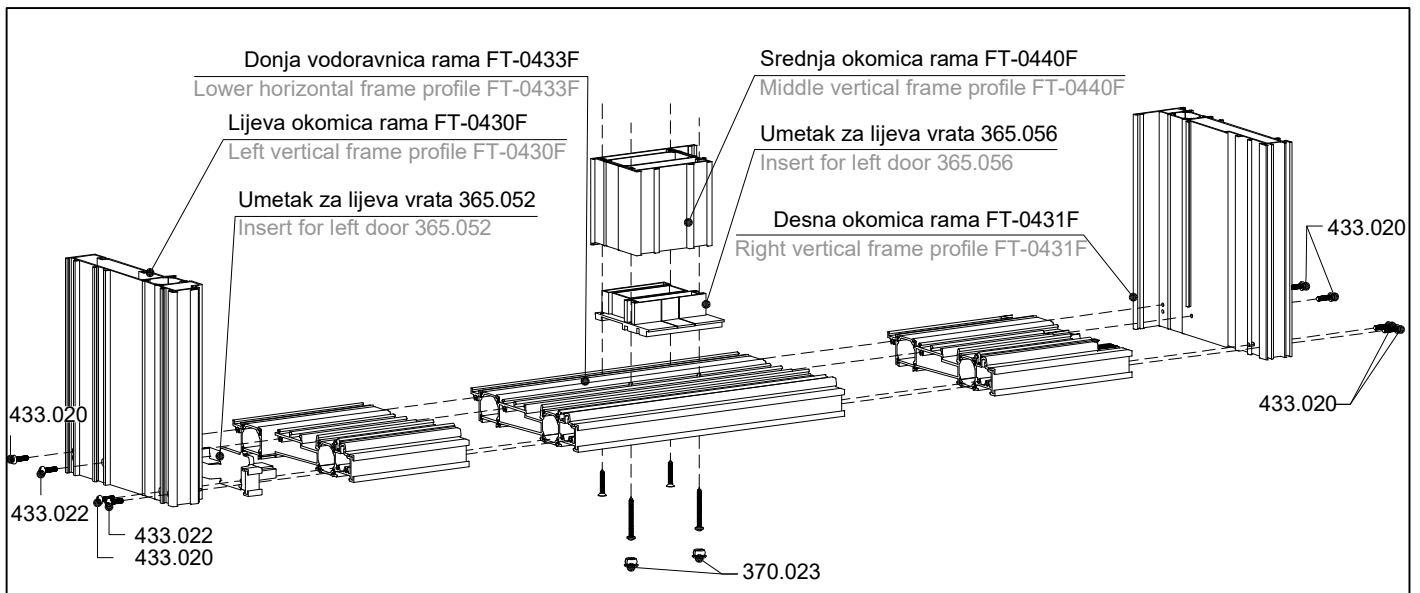
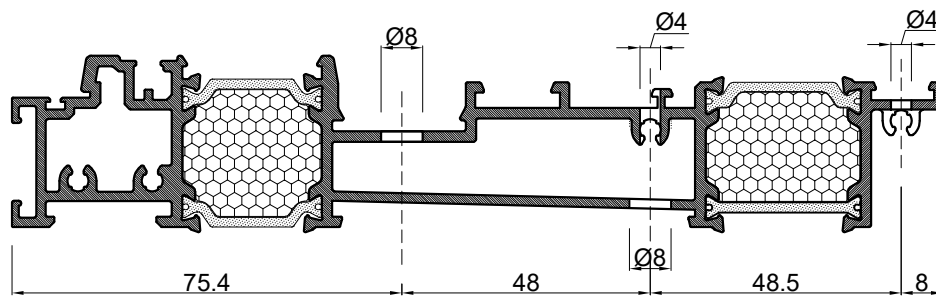
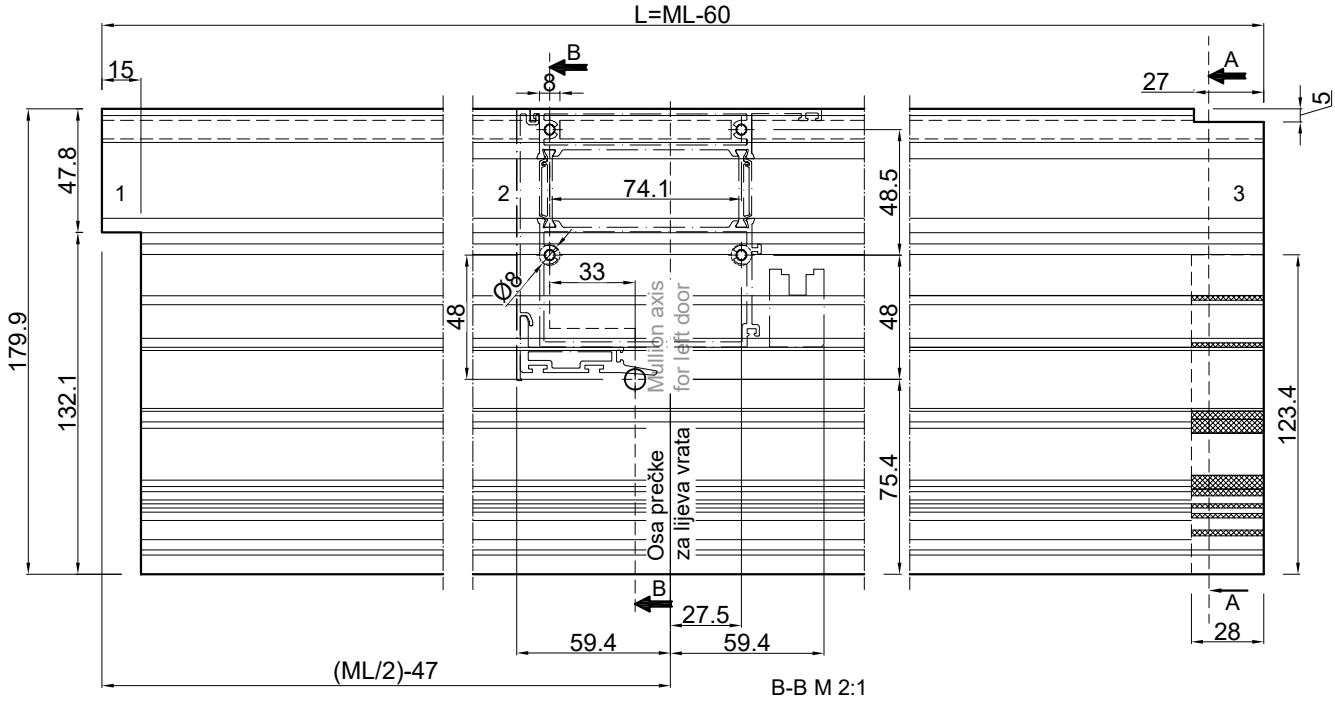
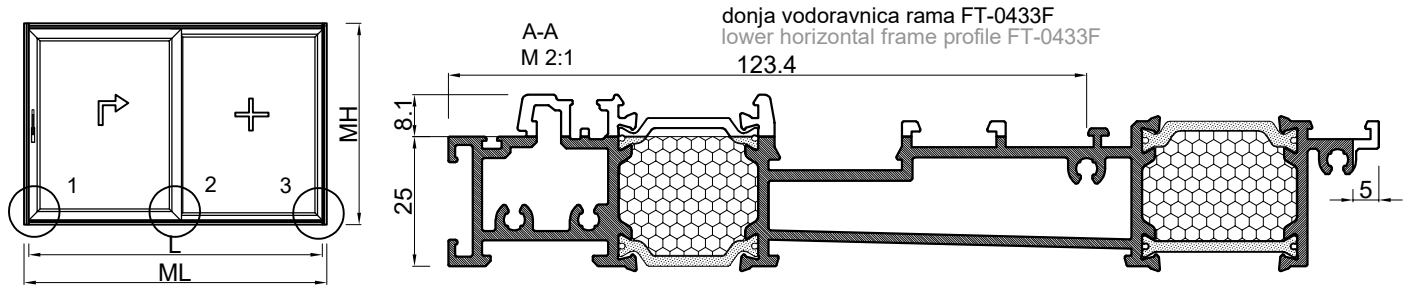

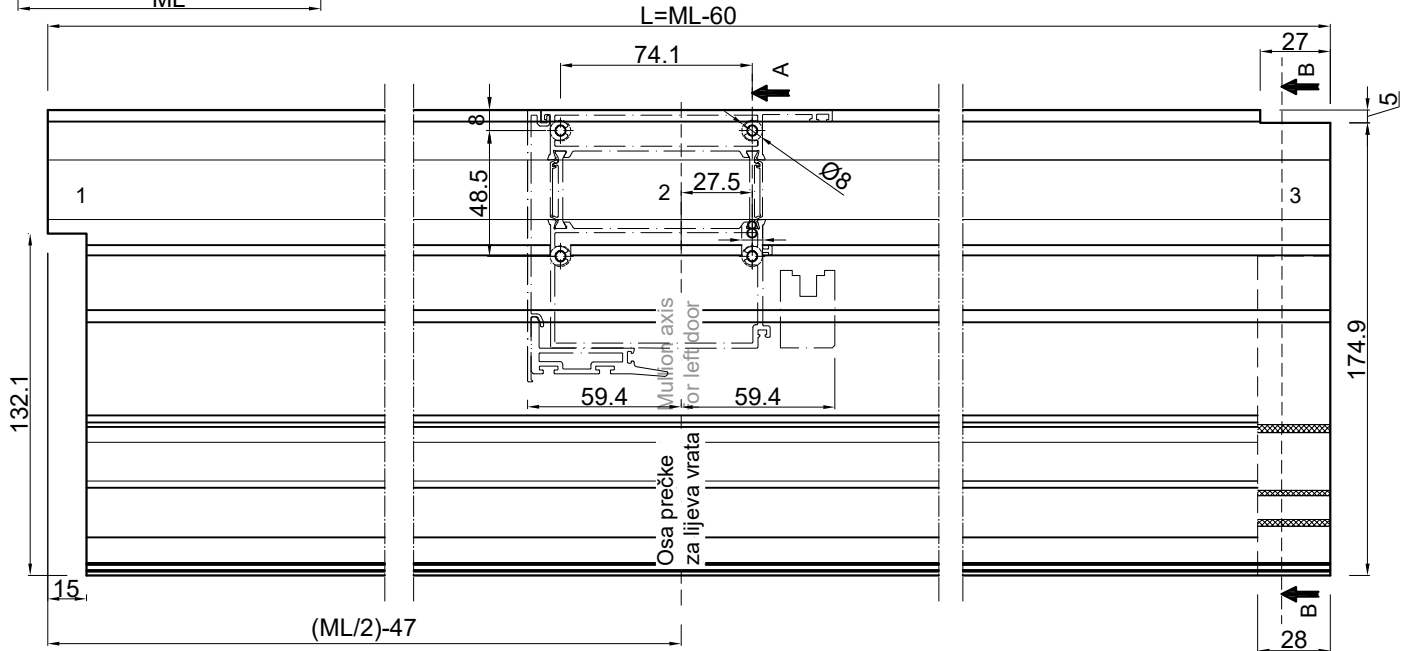
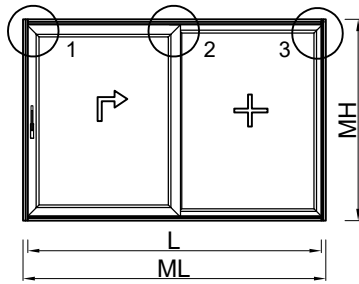

A-A
M 2:1
FT-0432F

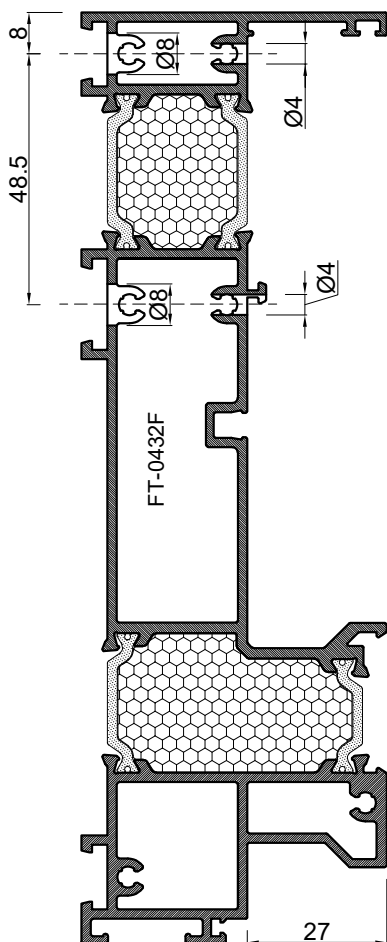

B-B
M 2:1

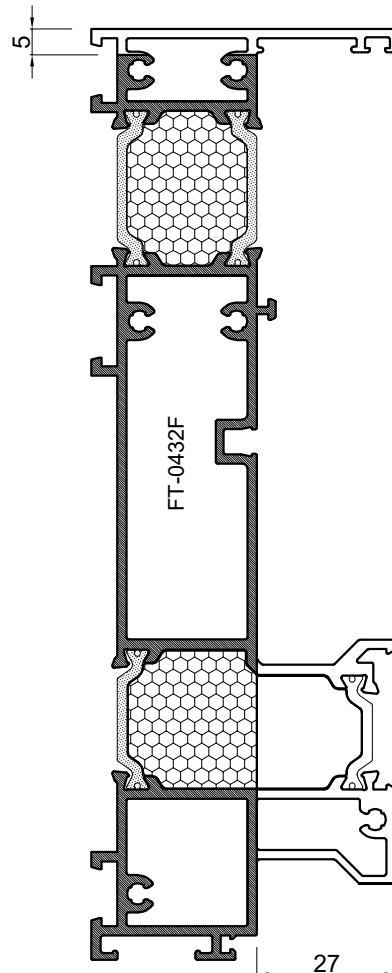

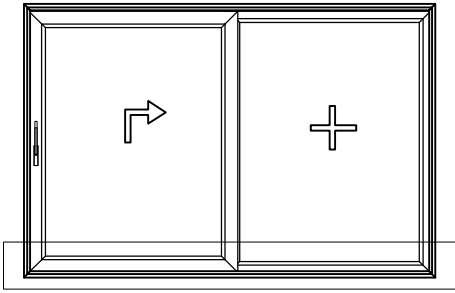

M 2:1 presjek A-A
M 2:1 cross section A-A

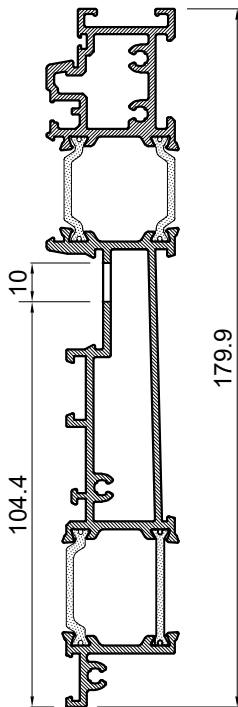

M 2:1 presjek B-B
M 2:1 cross section B-B

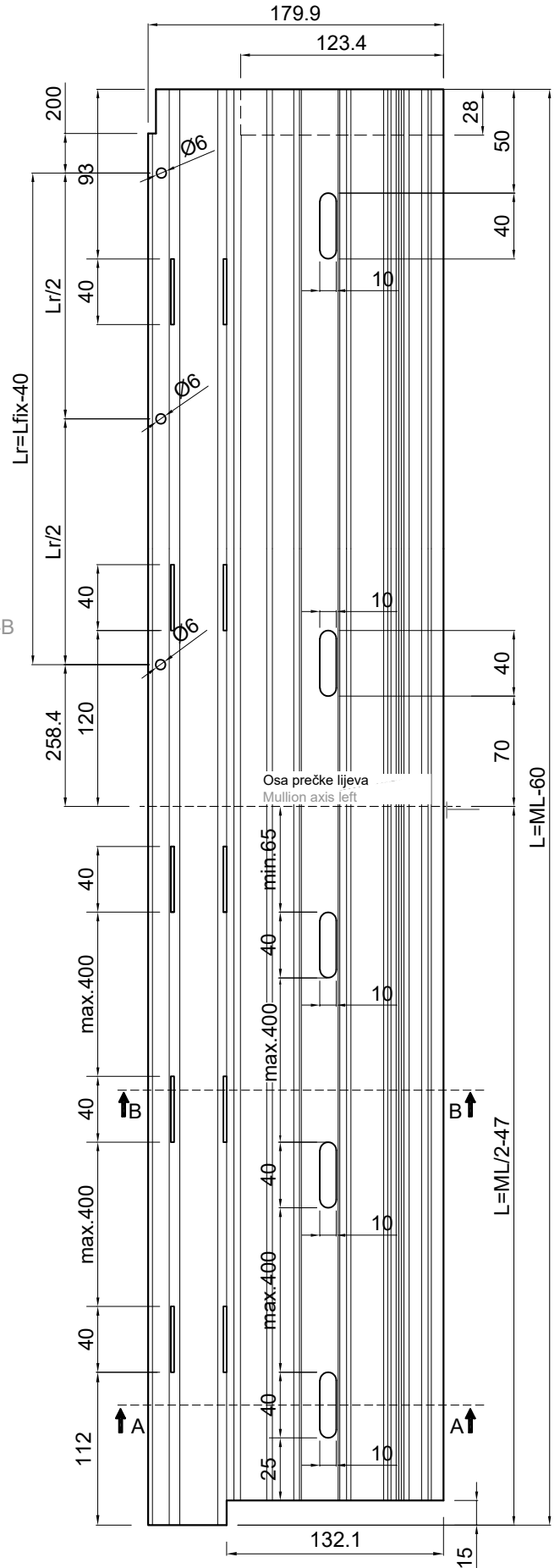
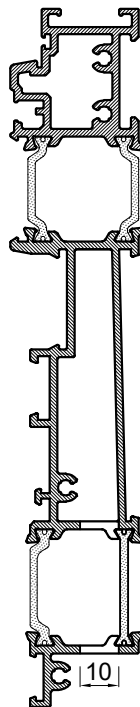

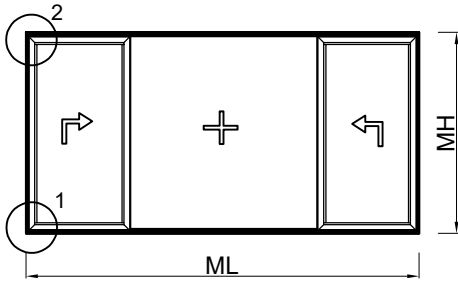

presjek A-A M 1:1
cross section A-AM 1:1

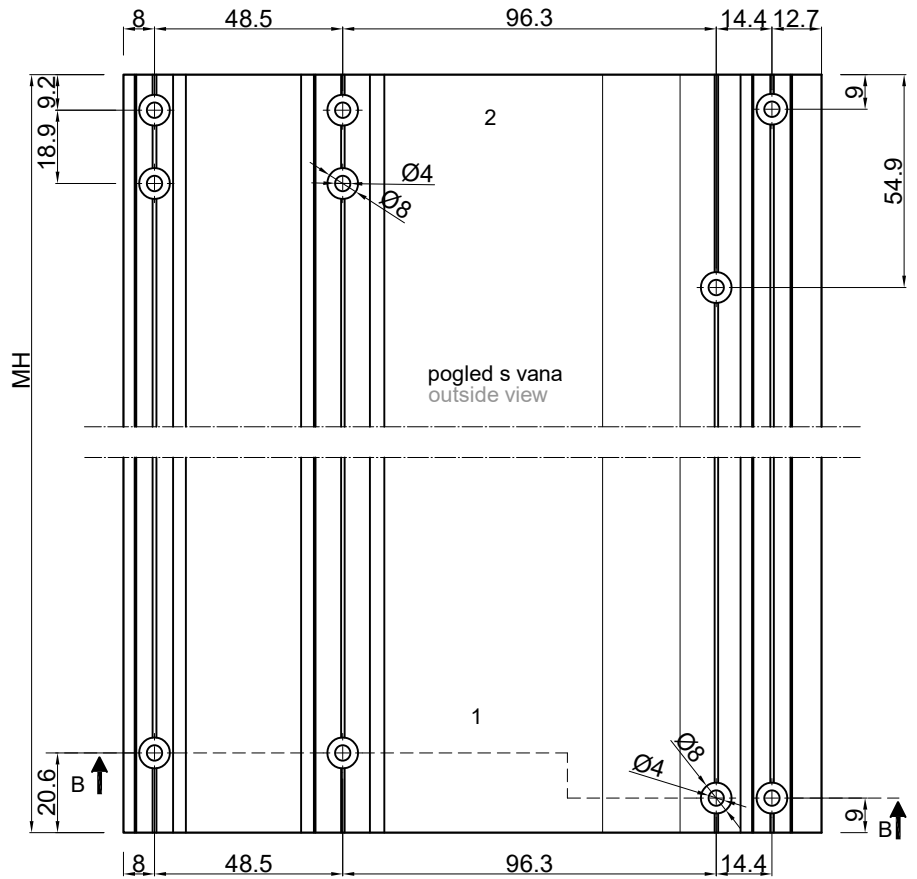
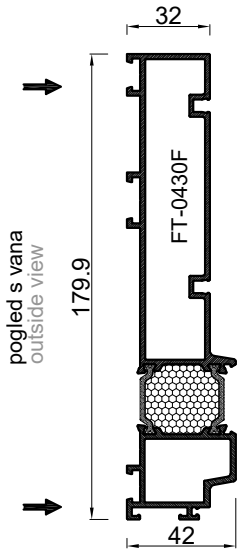

presjek B-B M 1.5:1
cross section B-B M 1.5:1

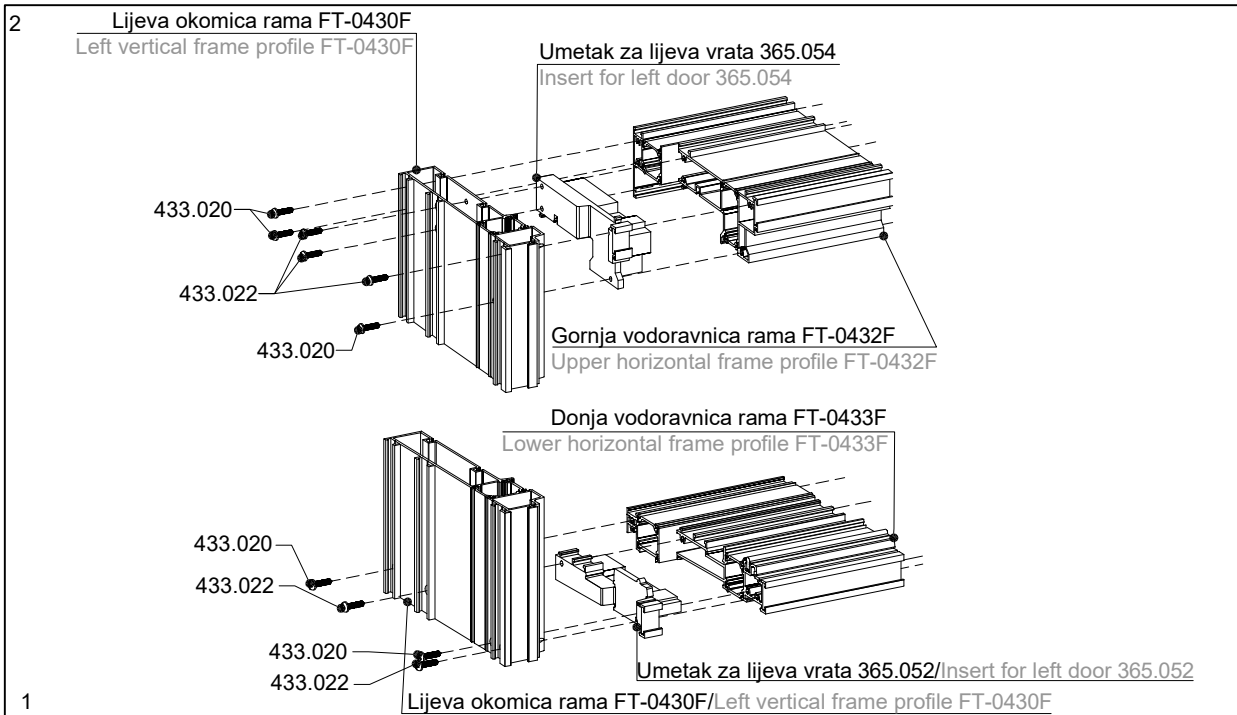
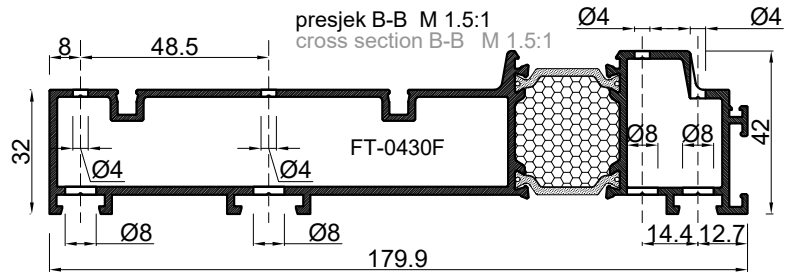

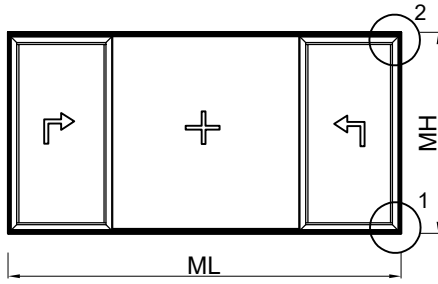

presjek A-AM 1:1
cross section A-AM 1:1

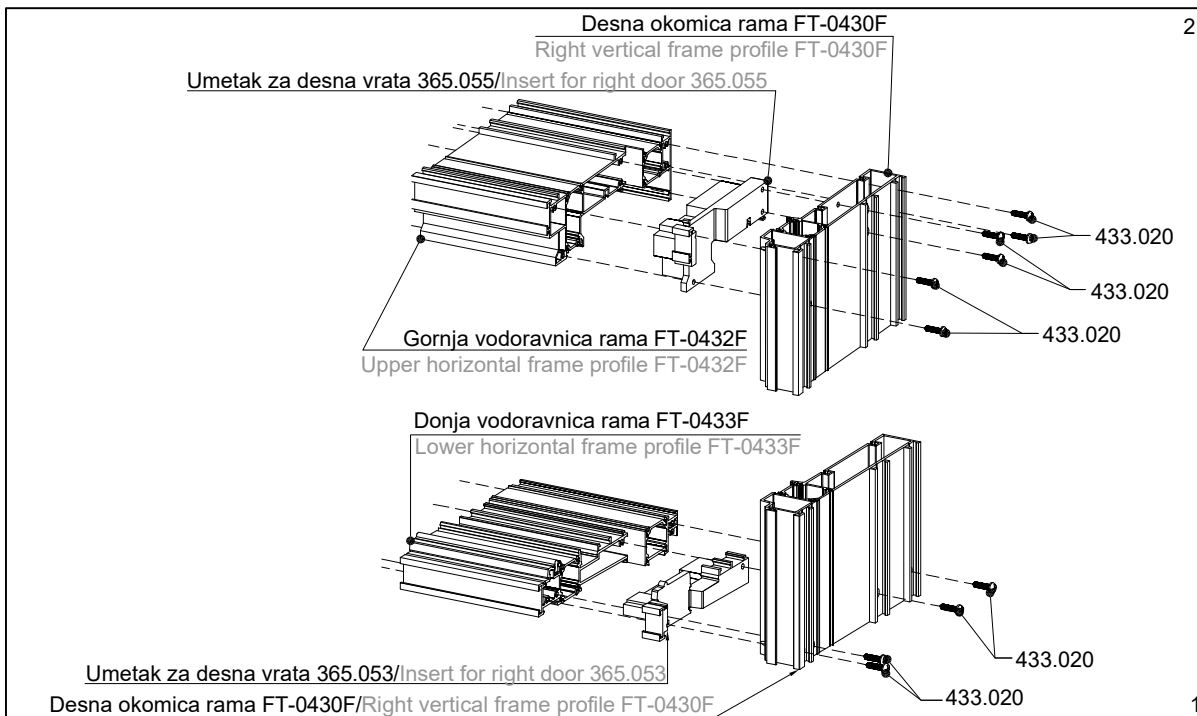
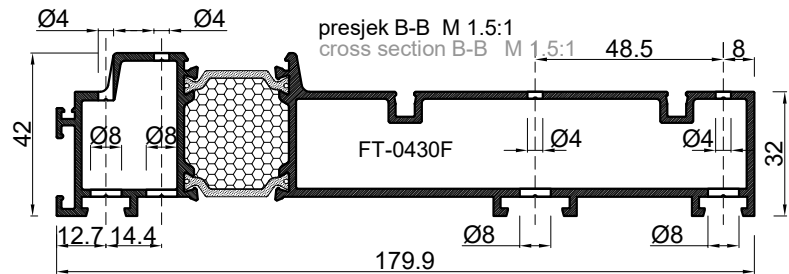
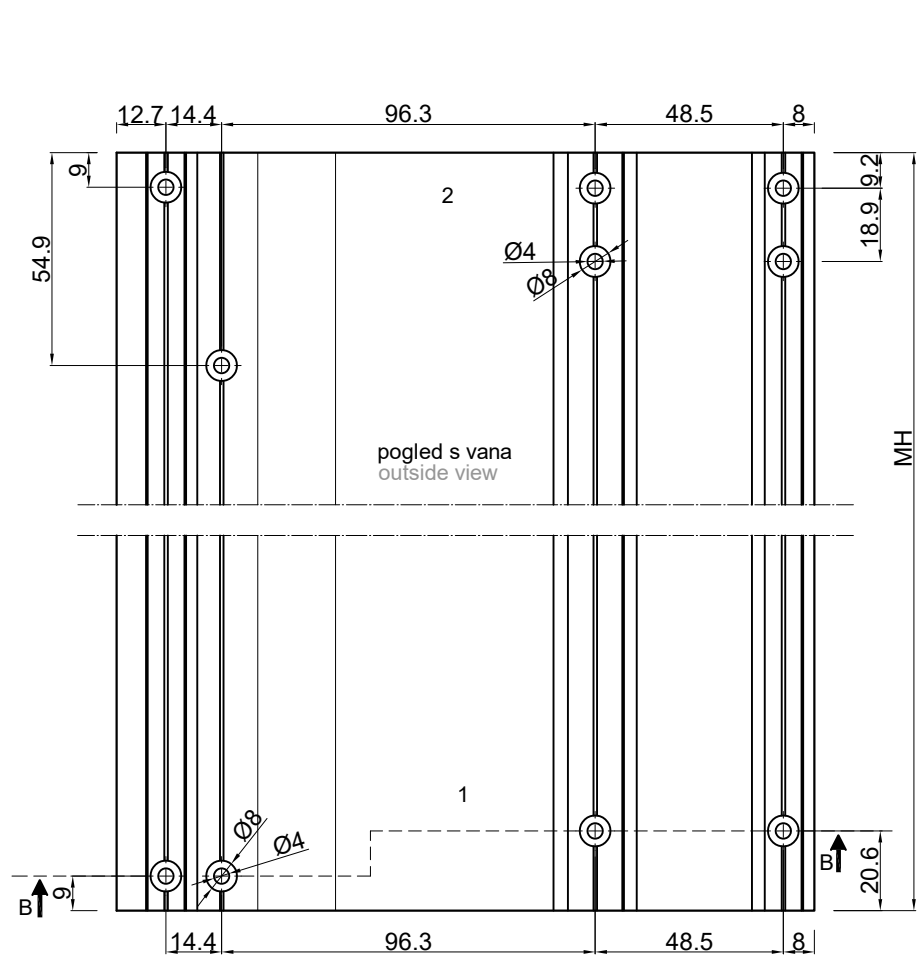
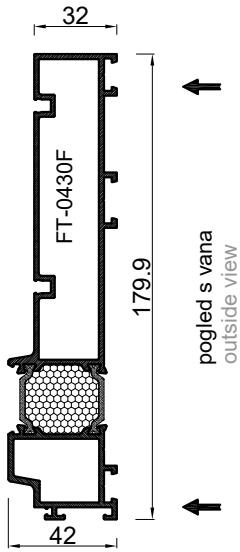

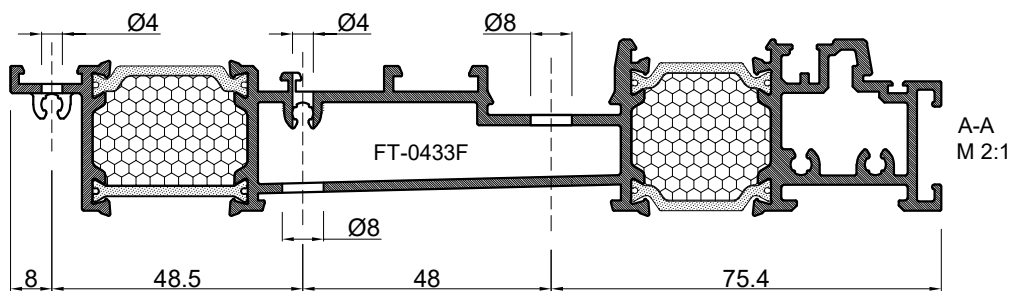
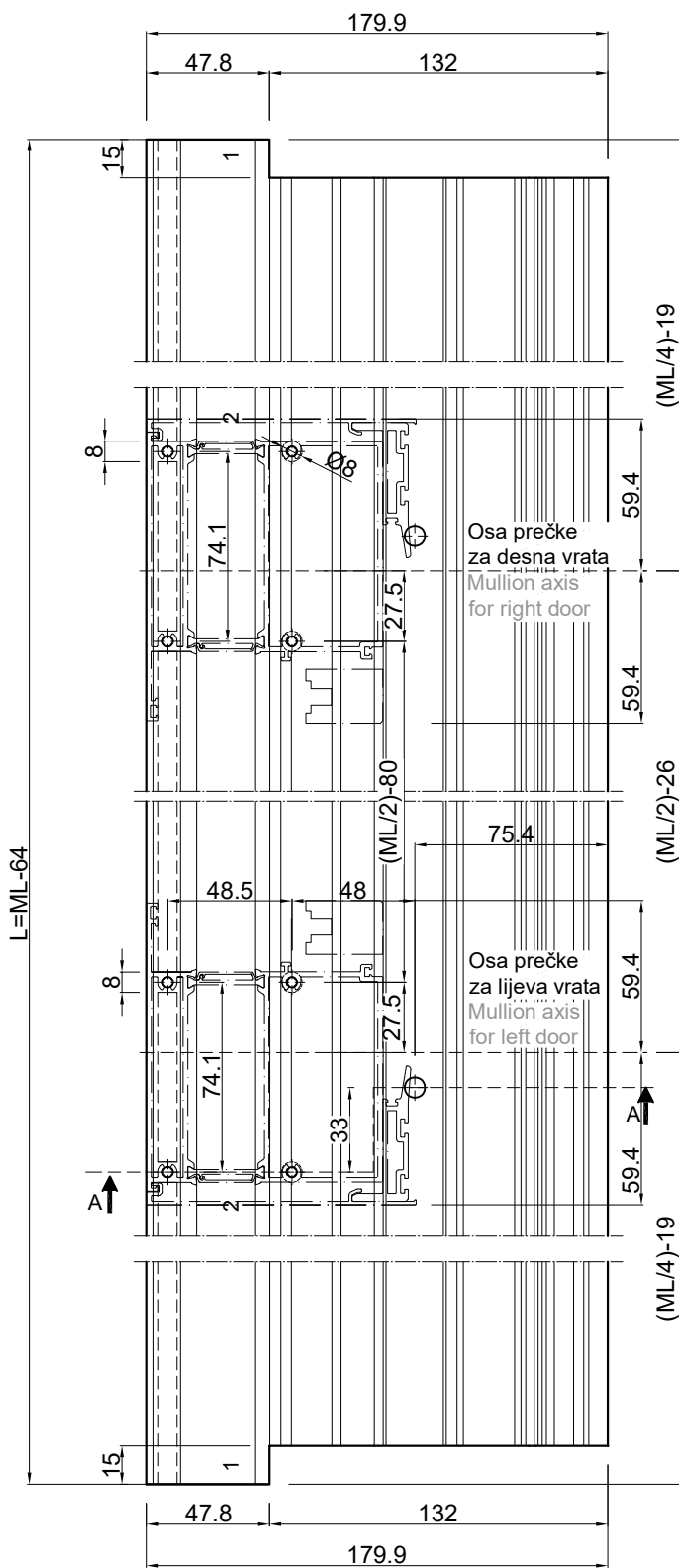
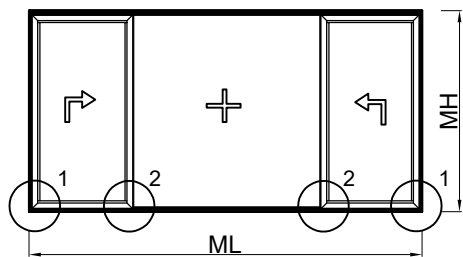

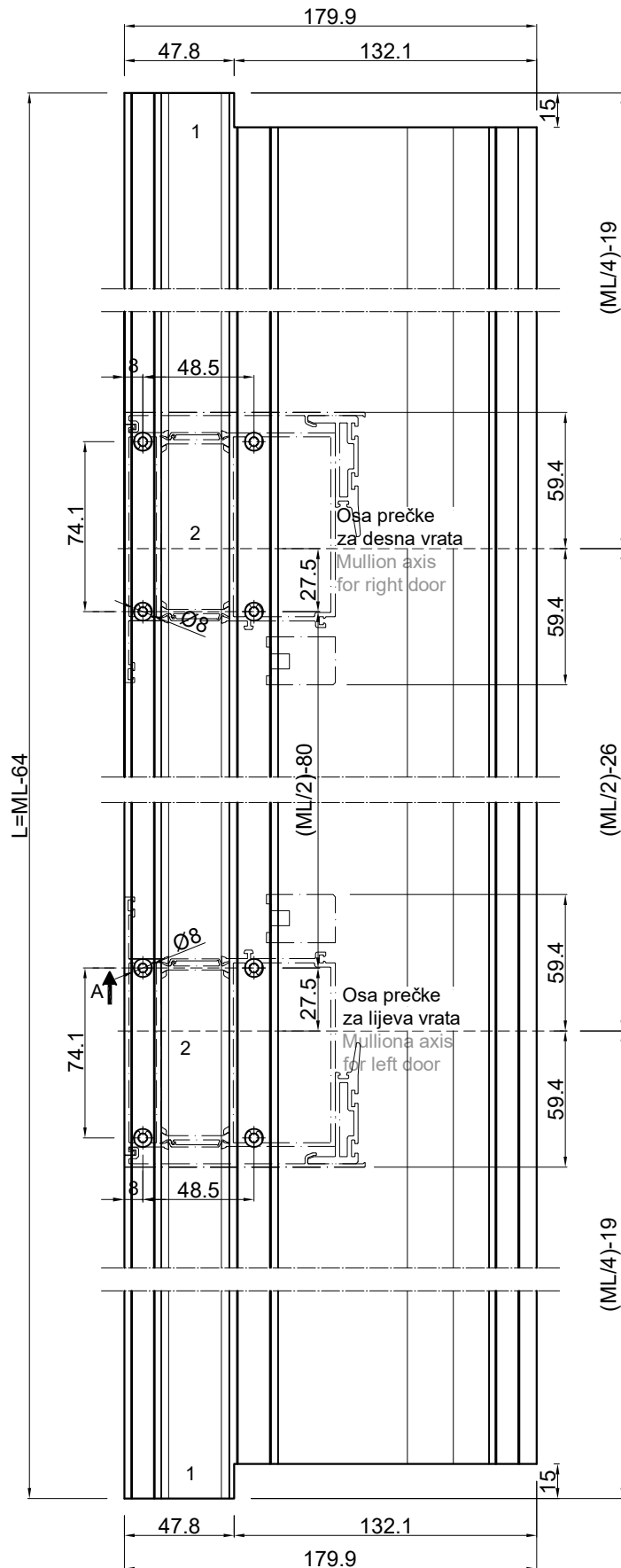
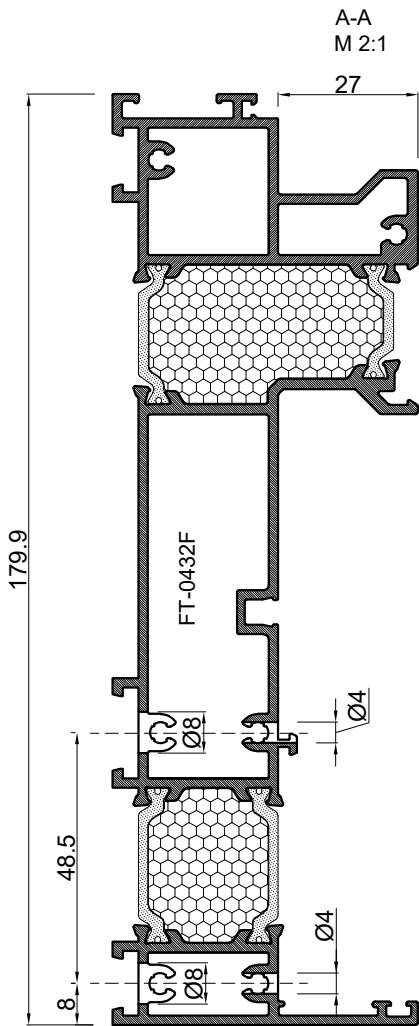
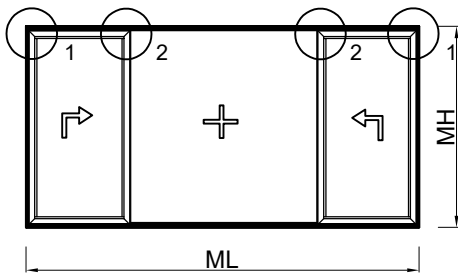

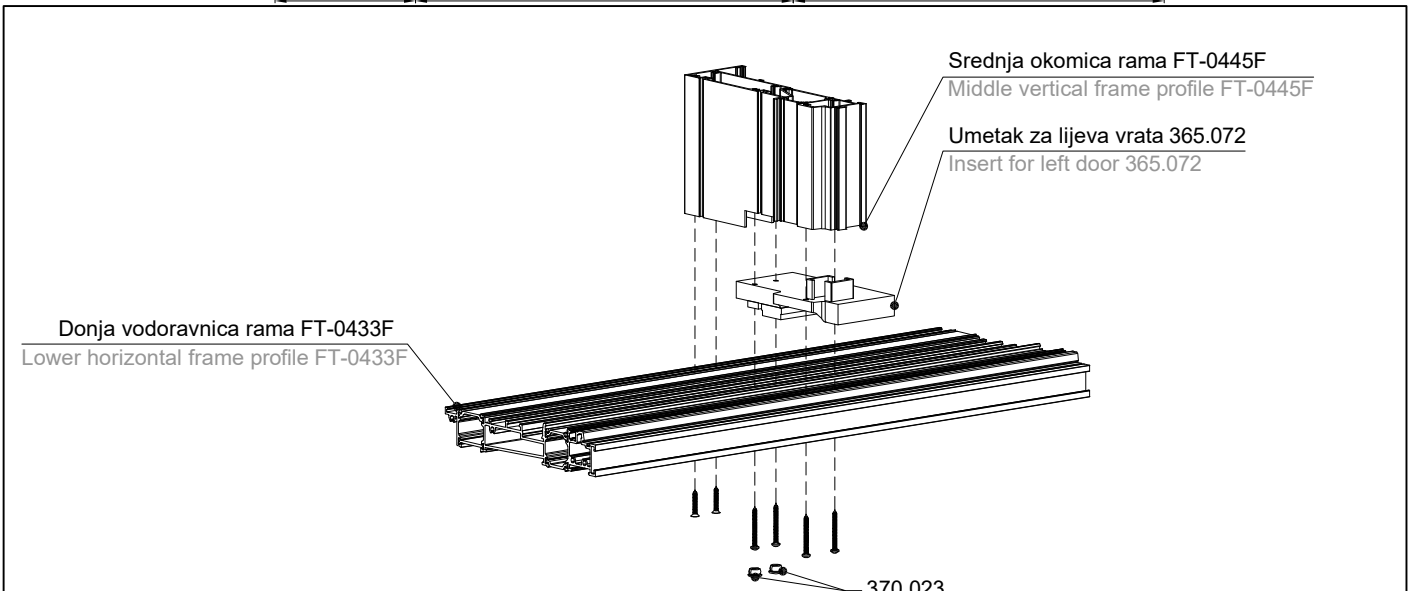
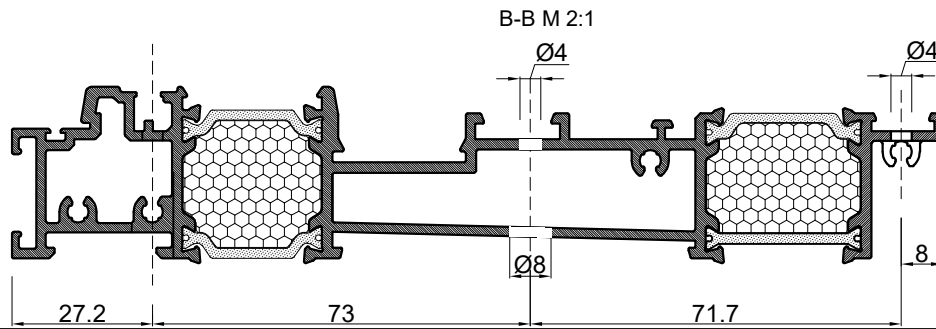
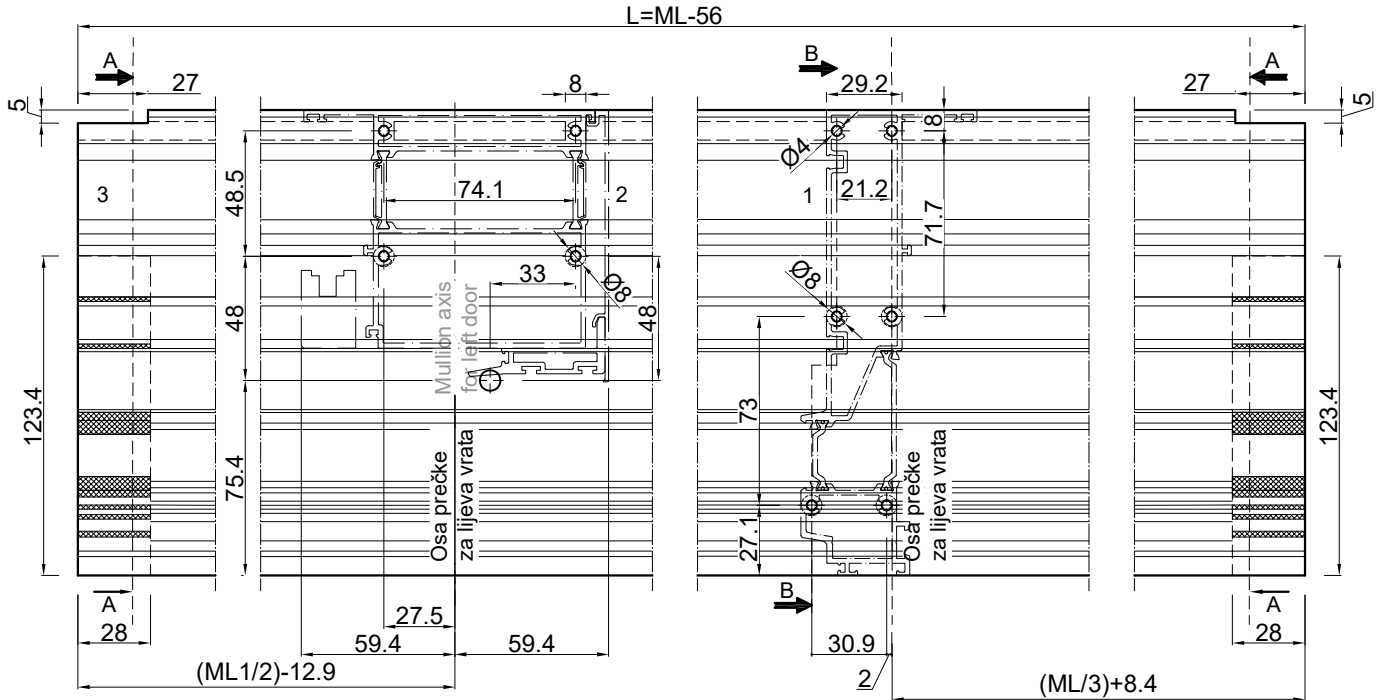
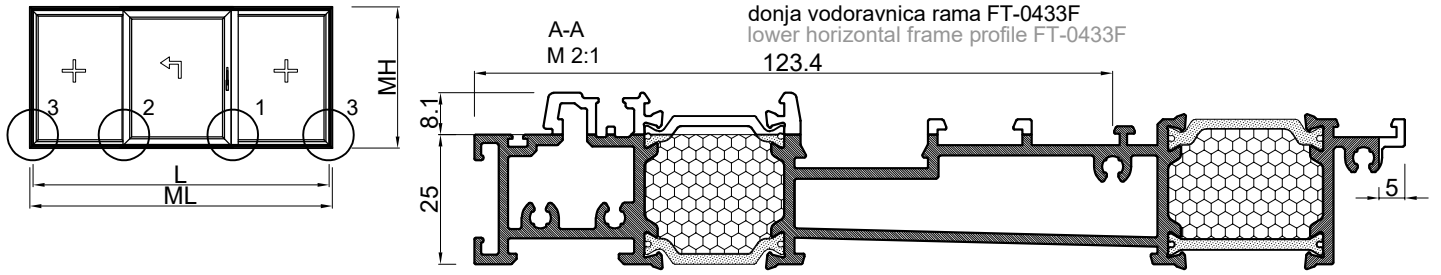

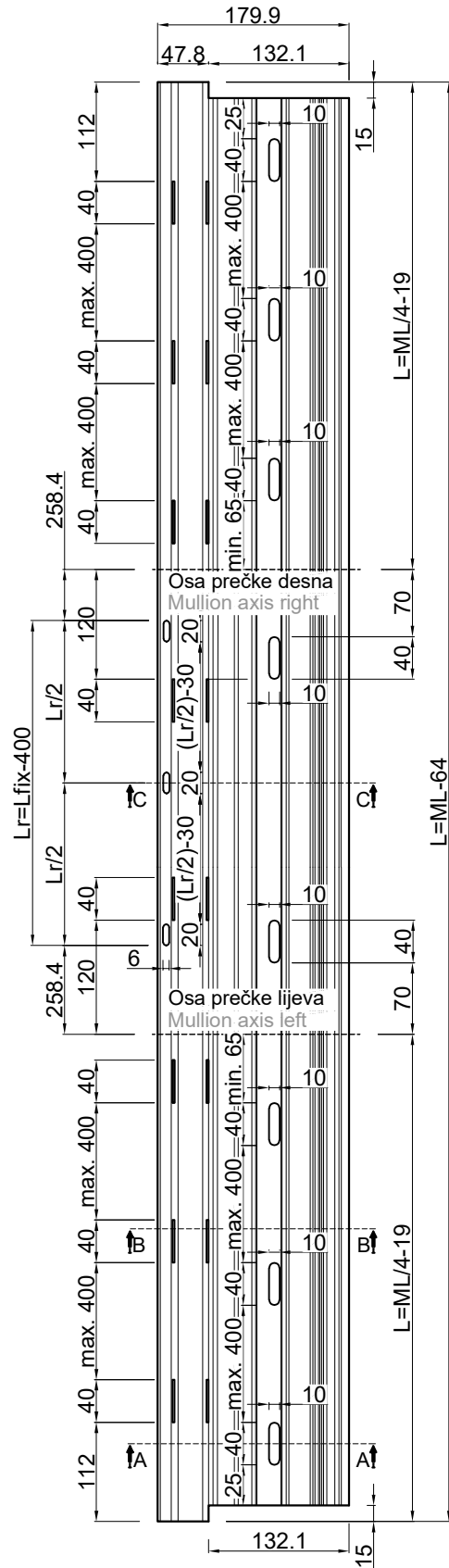
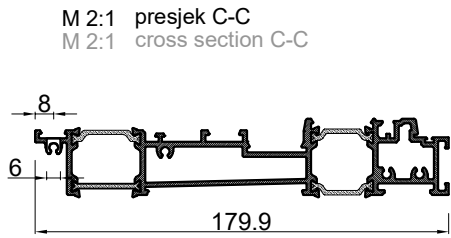
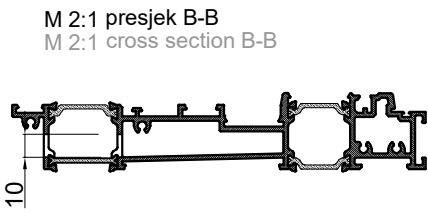
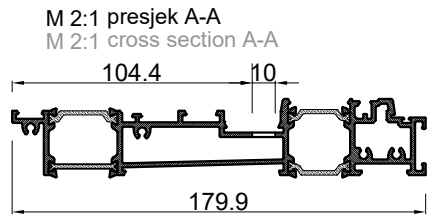
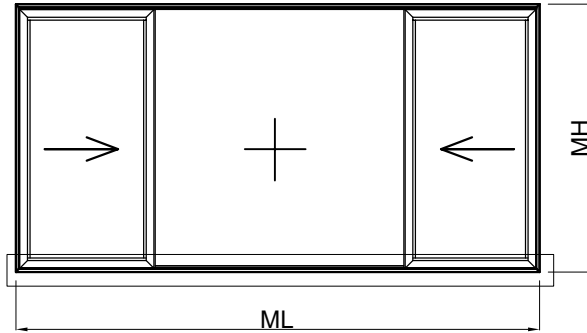

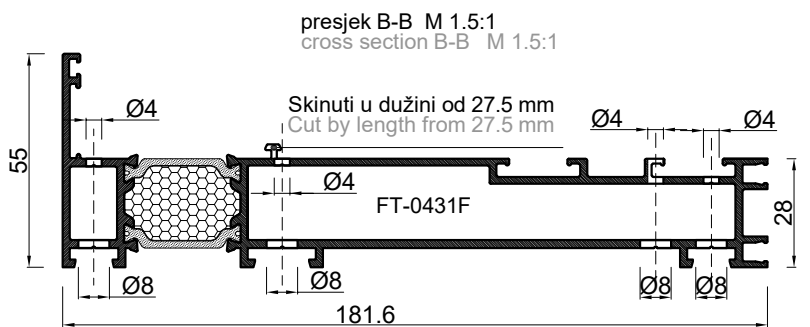
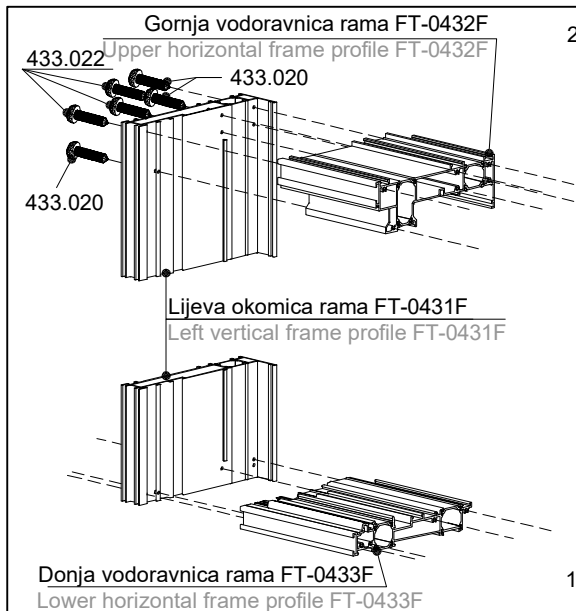
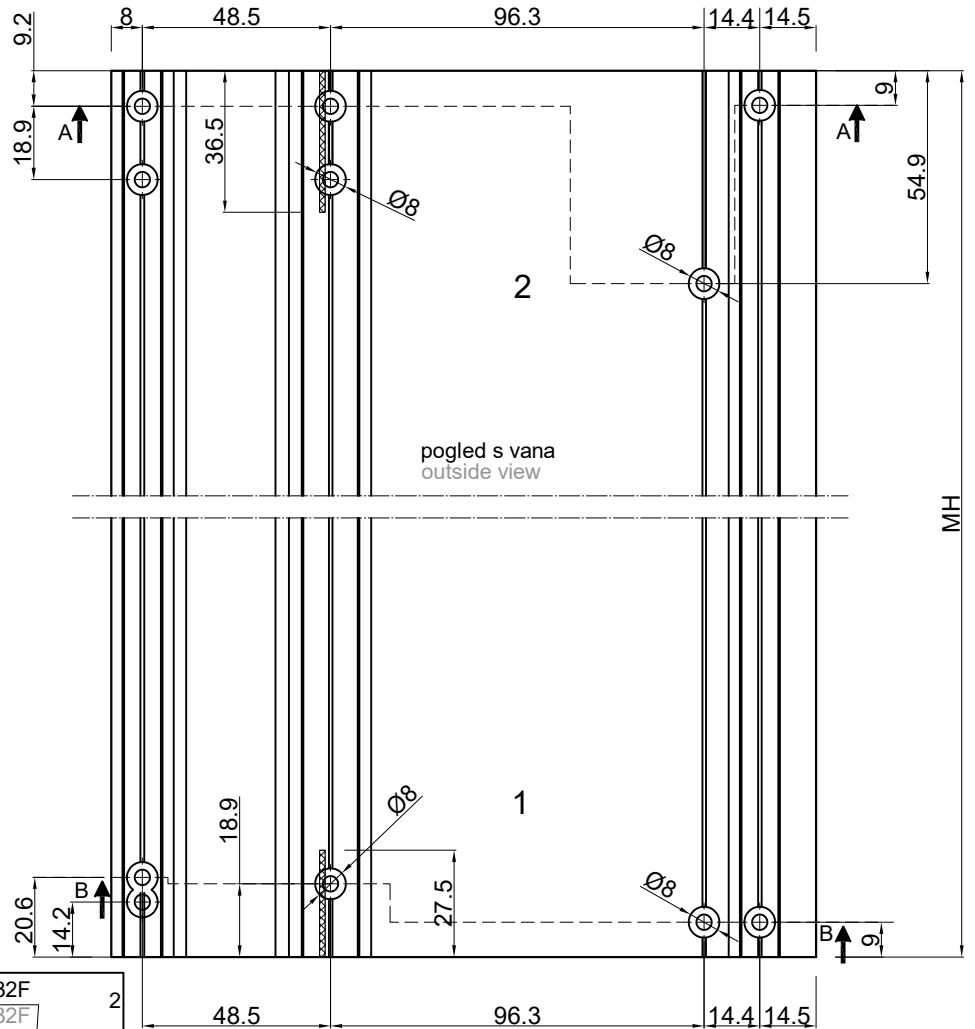
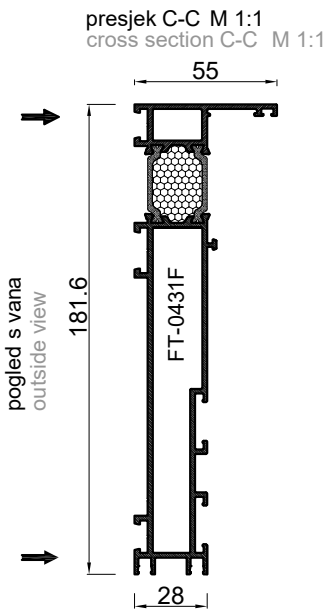
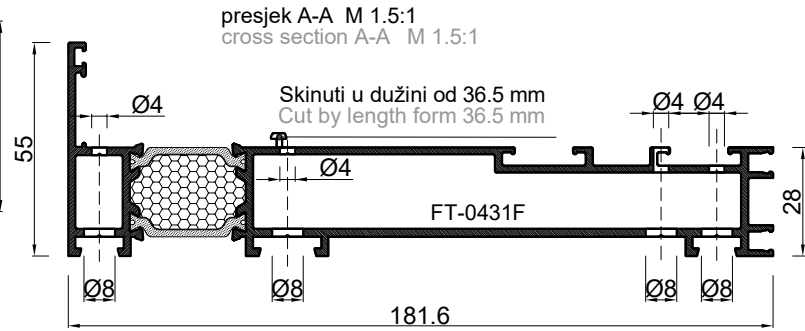
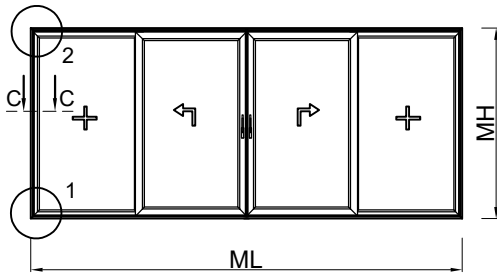

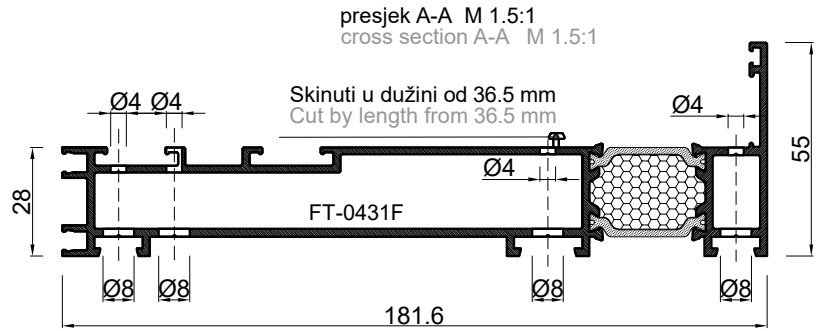
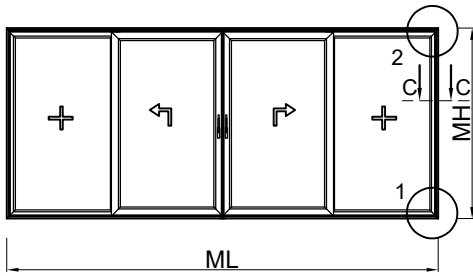

presjek C-C M 1:1
cross section C-C M 1:1

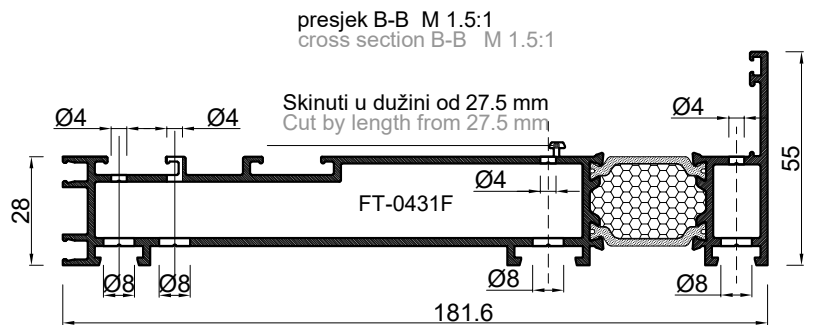
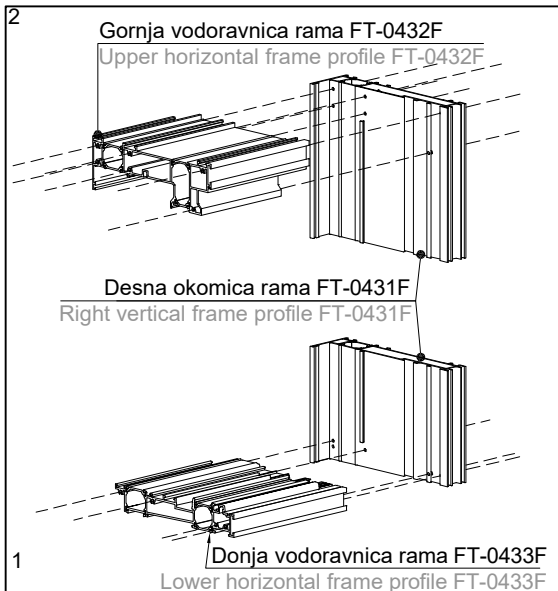
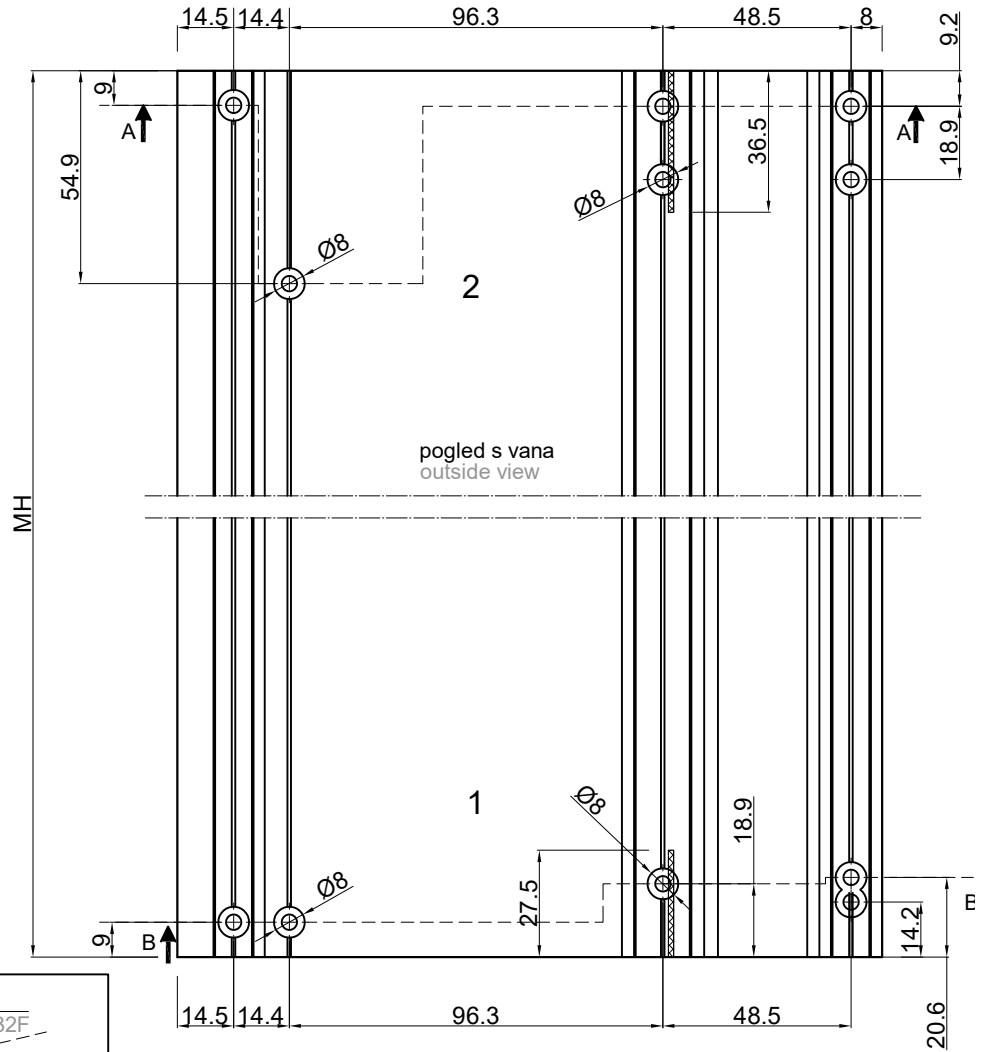
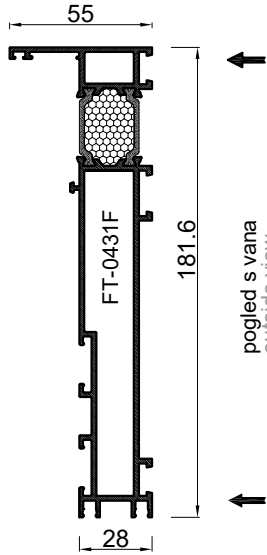

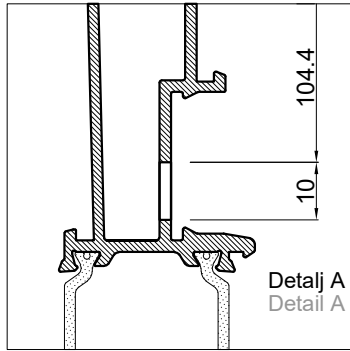
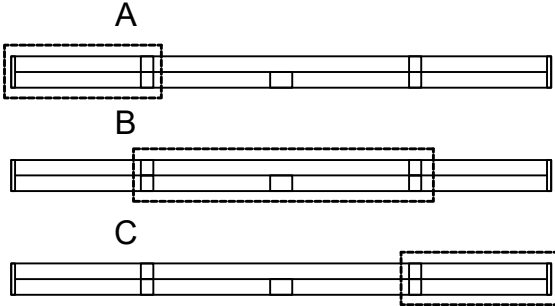
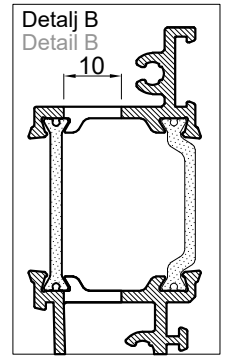
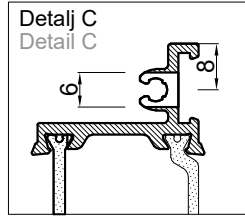
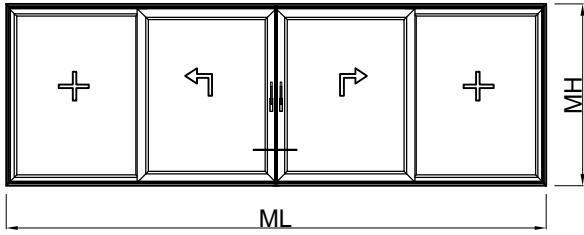

A

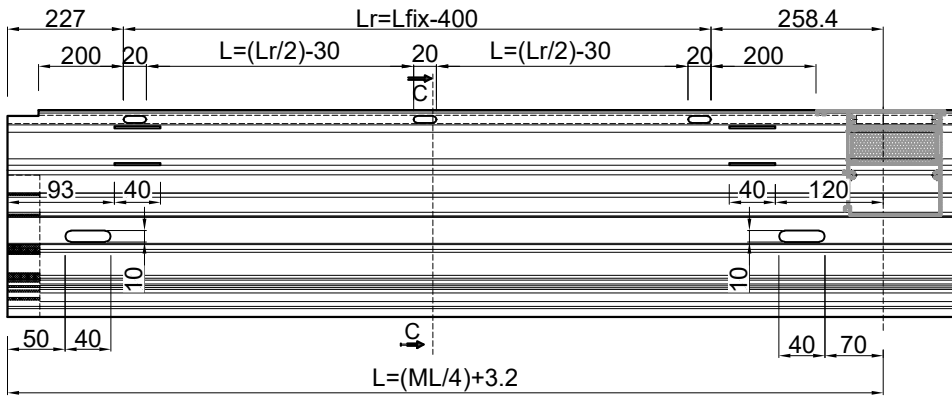

presjek C-C
cross section C-C

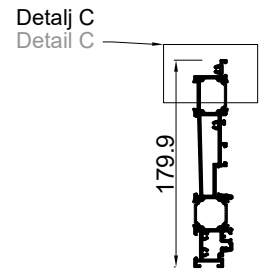

B

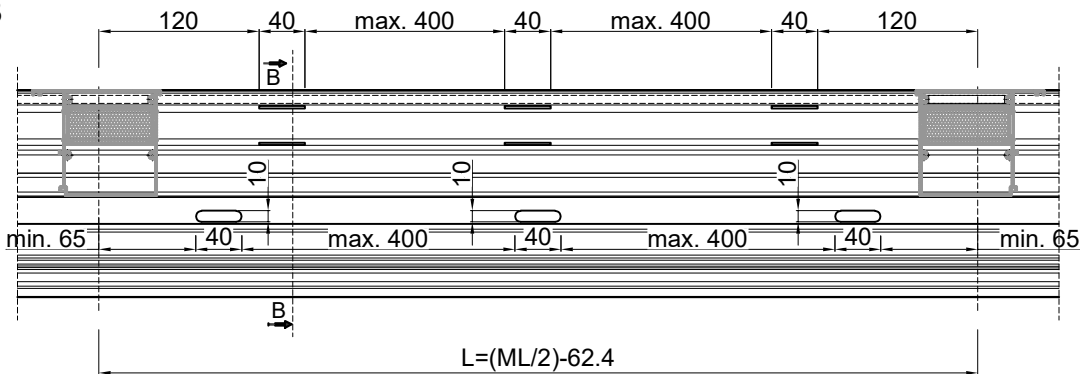

presjek B-B
cross section B-B

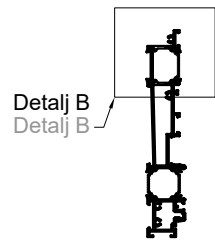

C

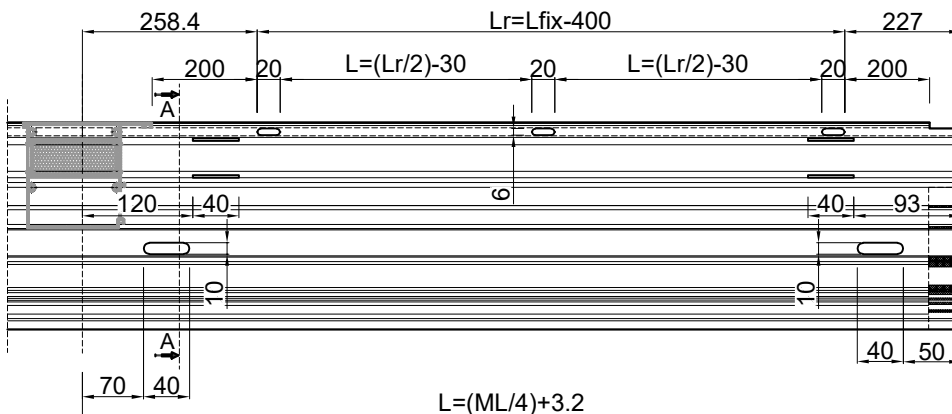

presjek A-A
cross section A-A

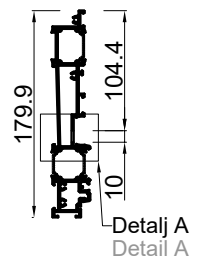

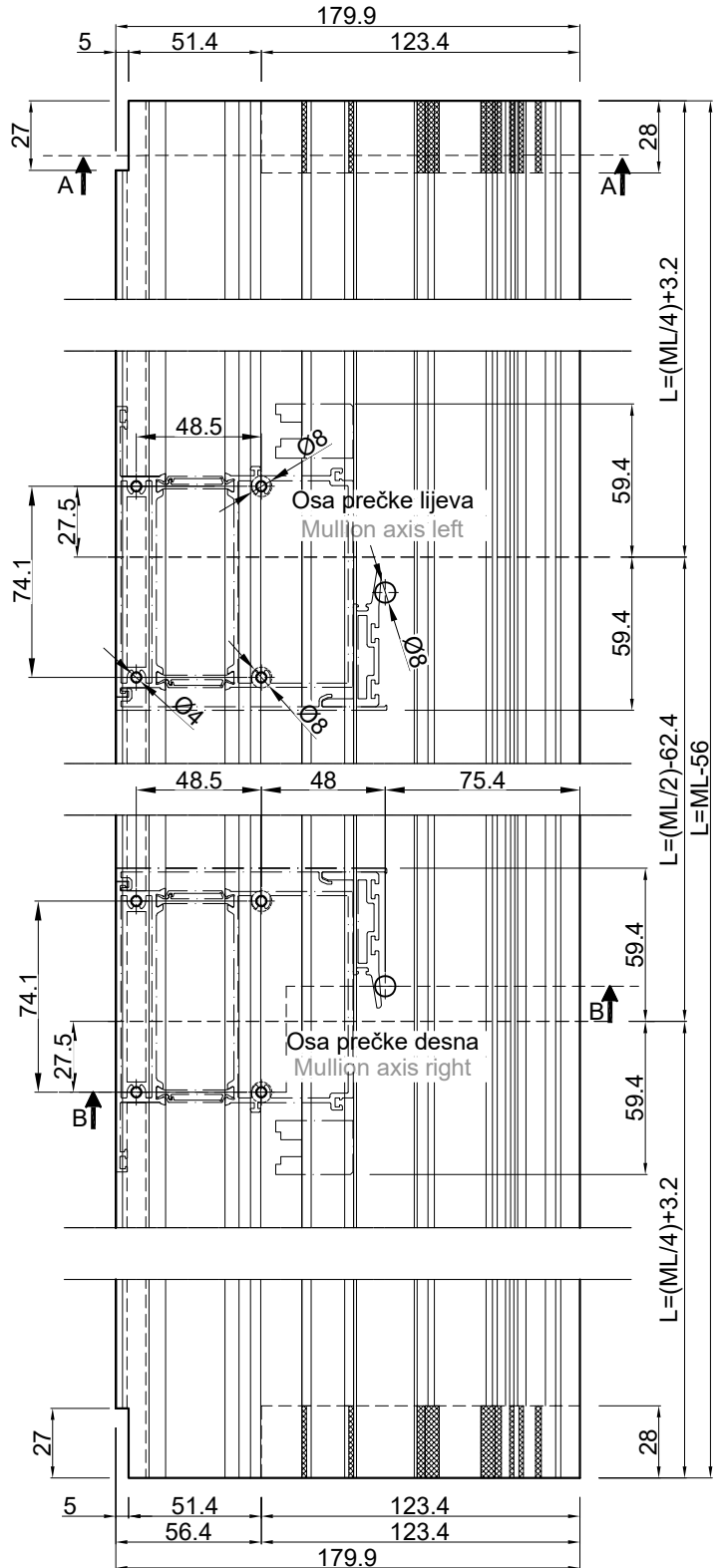
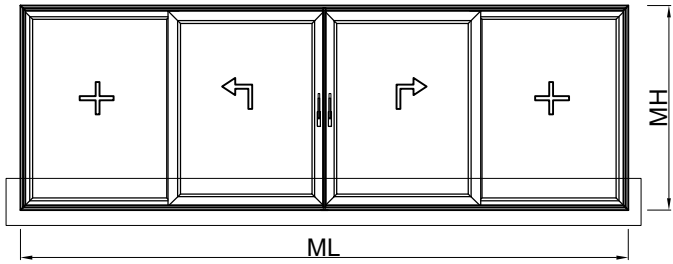

B-B M 2:1
FT-0433F

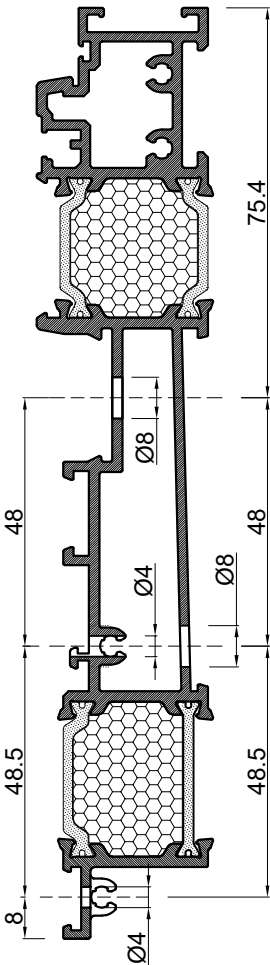

A-A M 2:1
FT-0433F

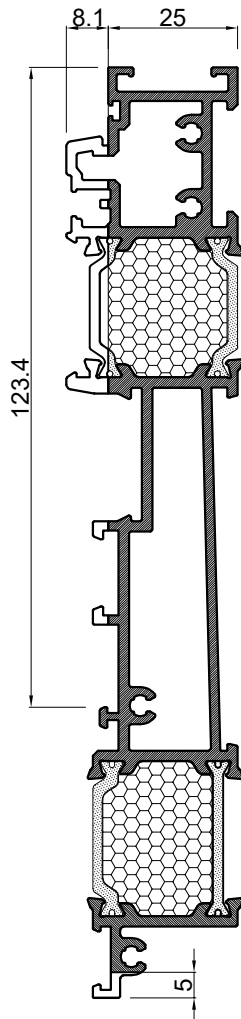

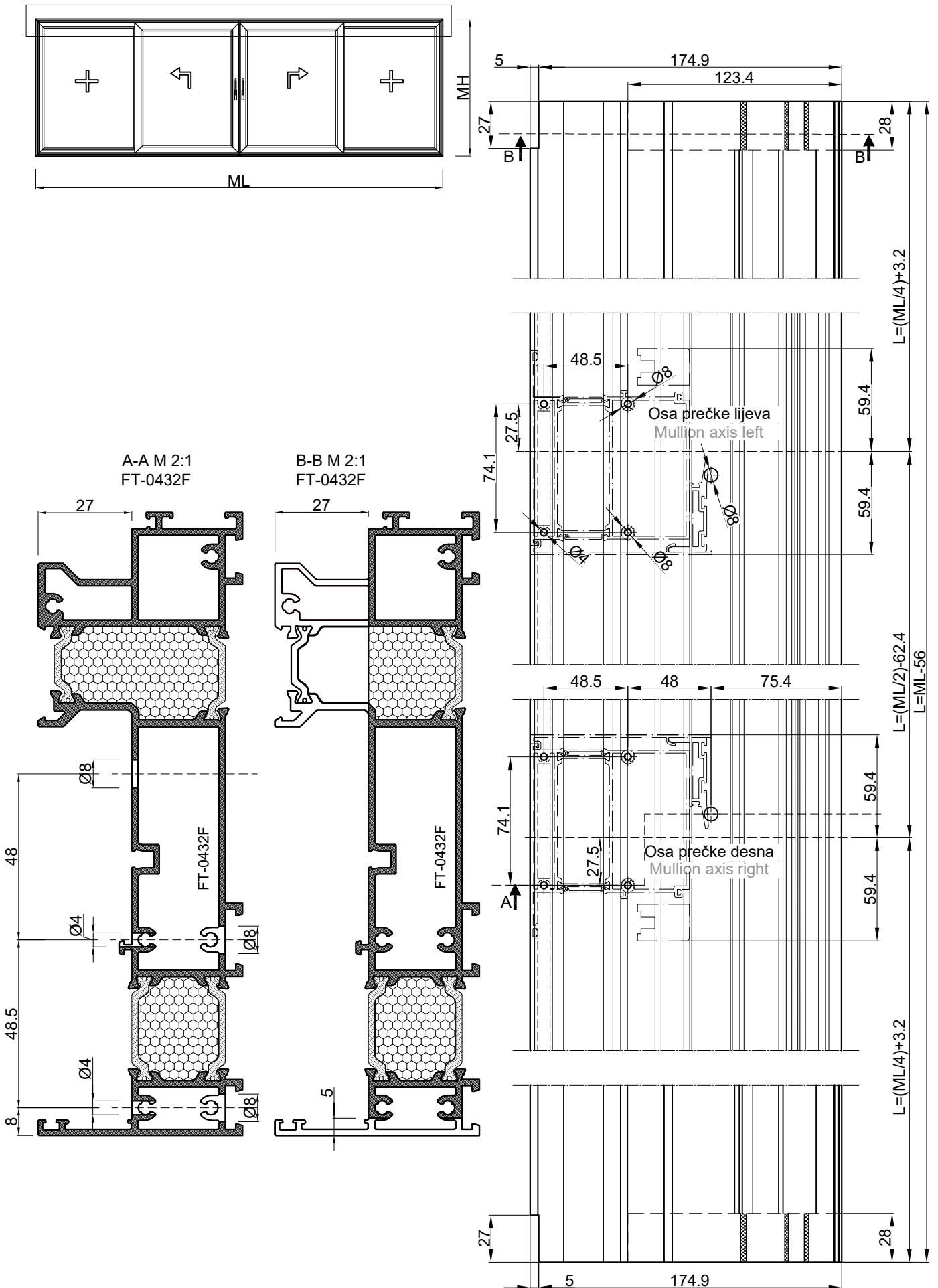

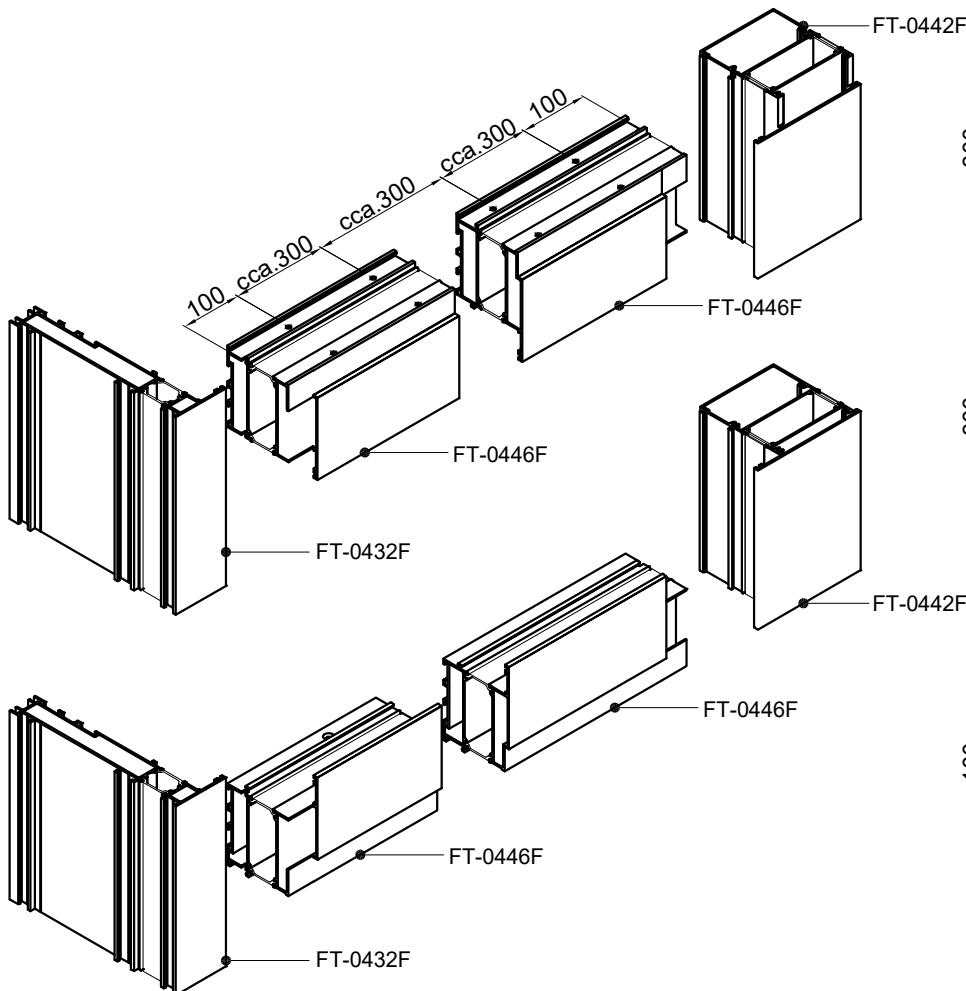
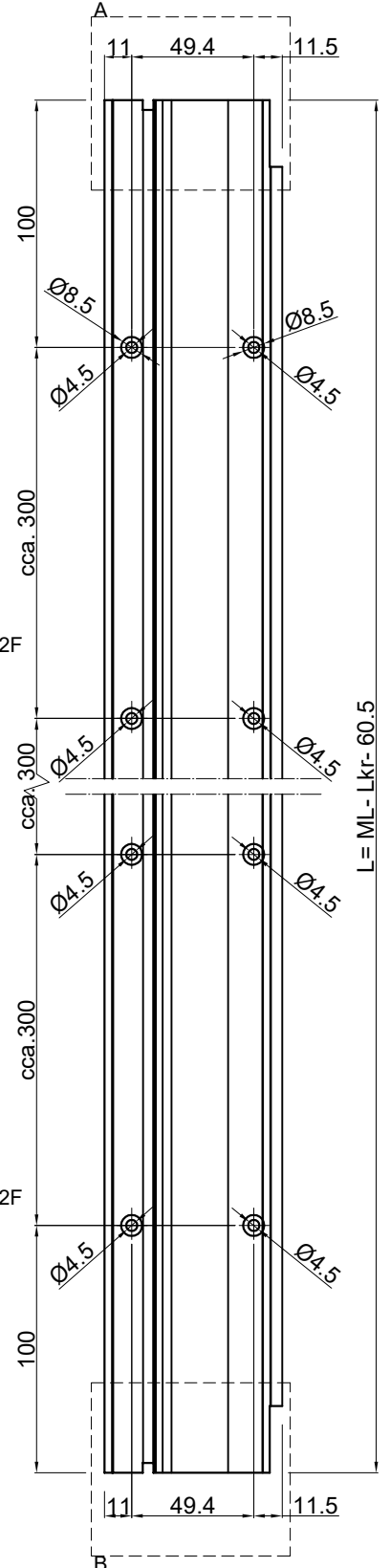
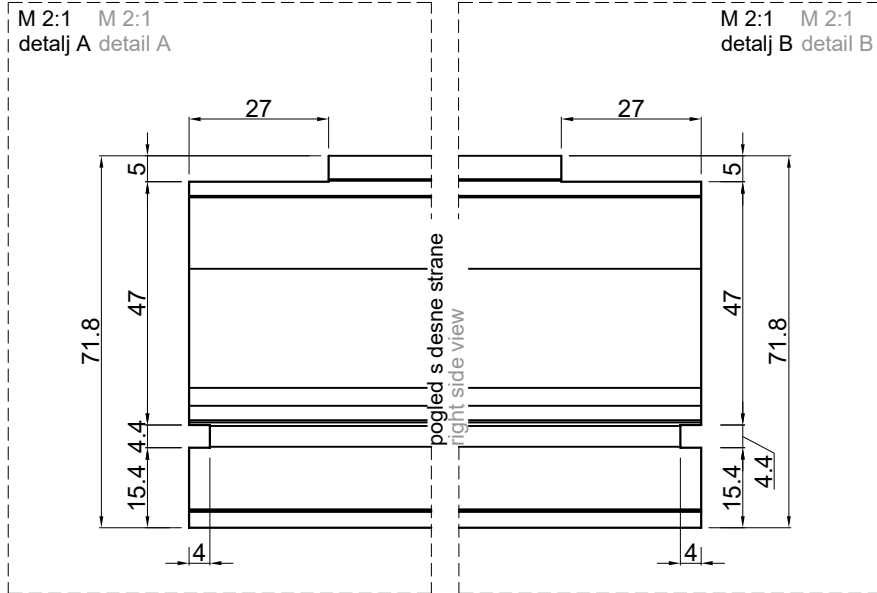
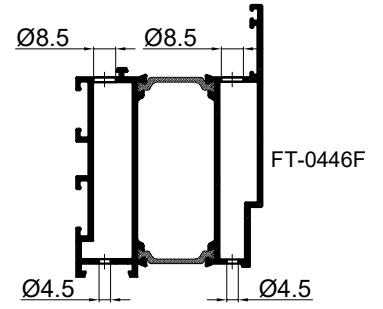
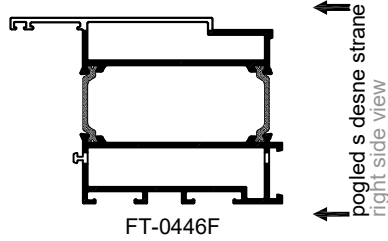
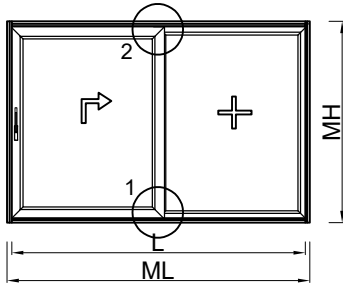

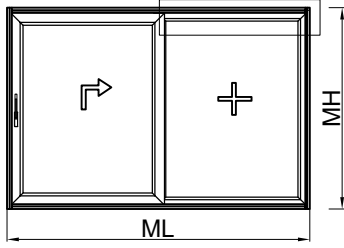

Spajanje profila FT-0446F za ram FT-0432F
Connection profile FT-0446F with frame FT-0432F

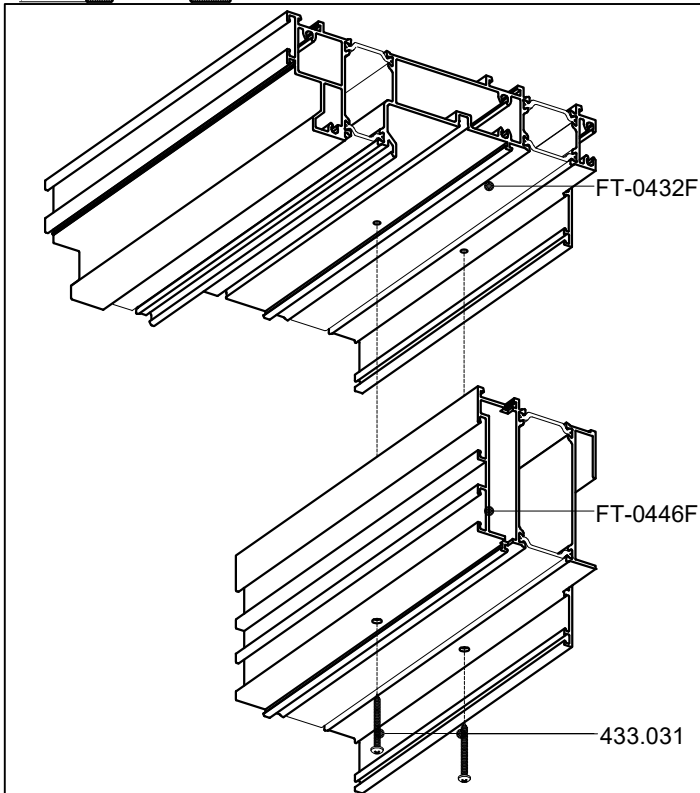
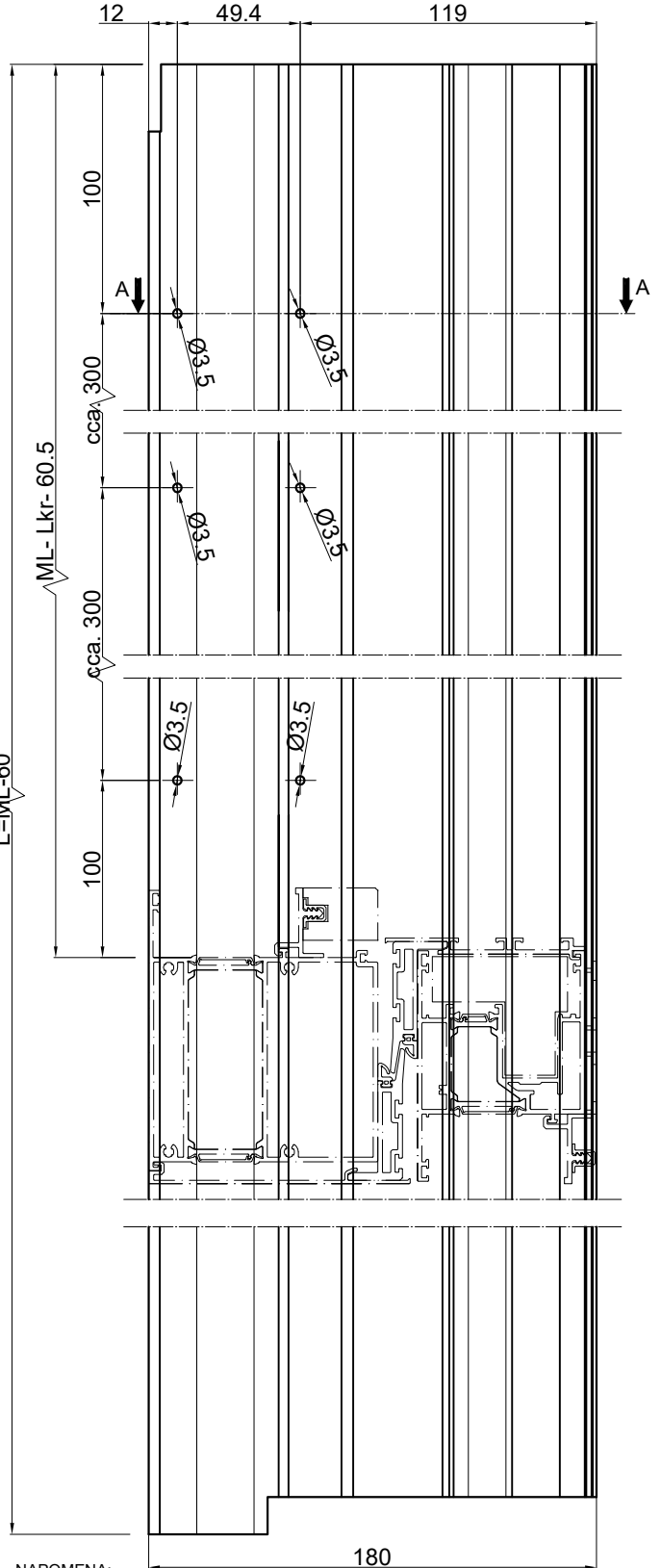
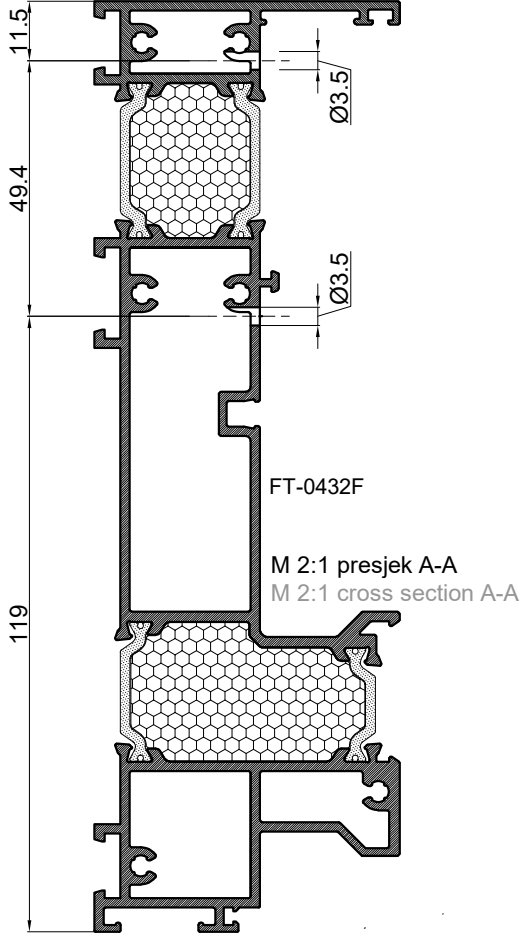
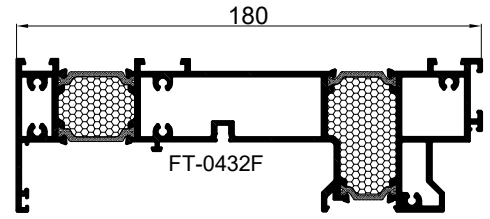

NAPOMENA:
REMARK:
Moguće koristiti profil FT-0446F kao šablon
Possible to use profile FT-0446F as template

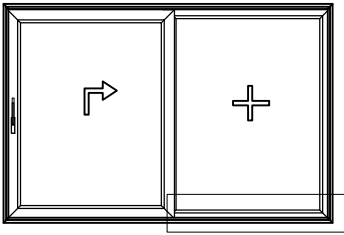

Spajanje profila FT-0446F za ram FT-0433F
Connection profile FT-0446F with frame
FT-0433F

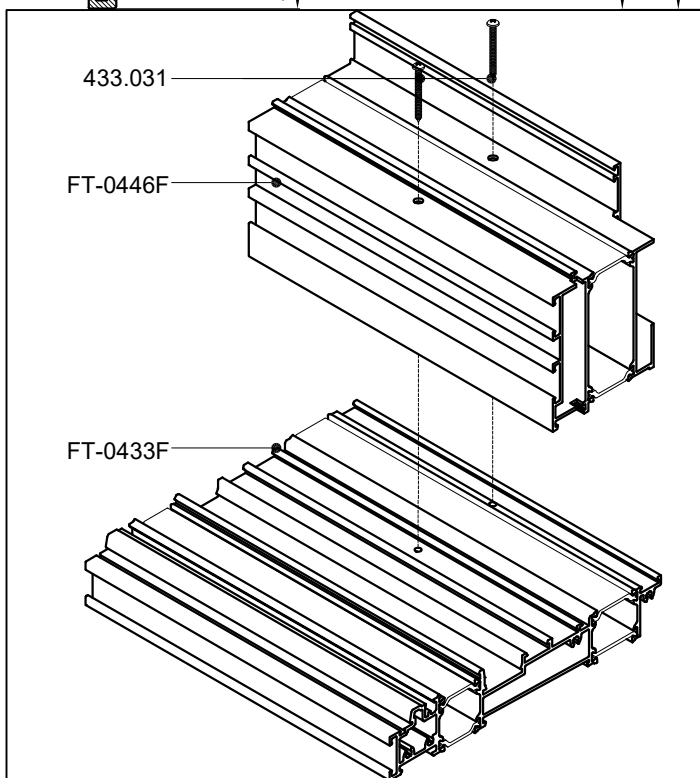
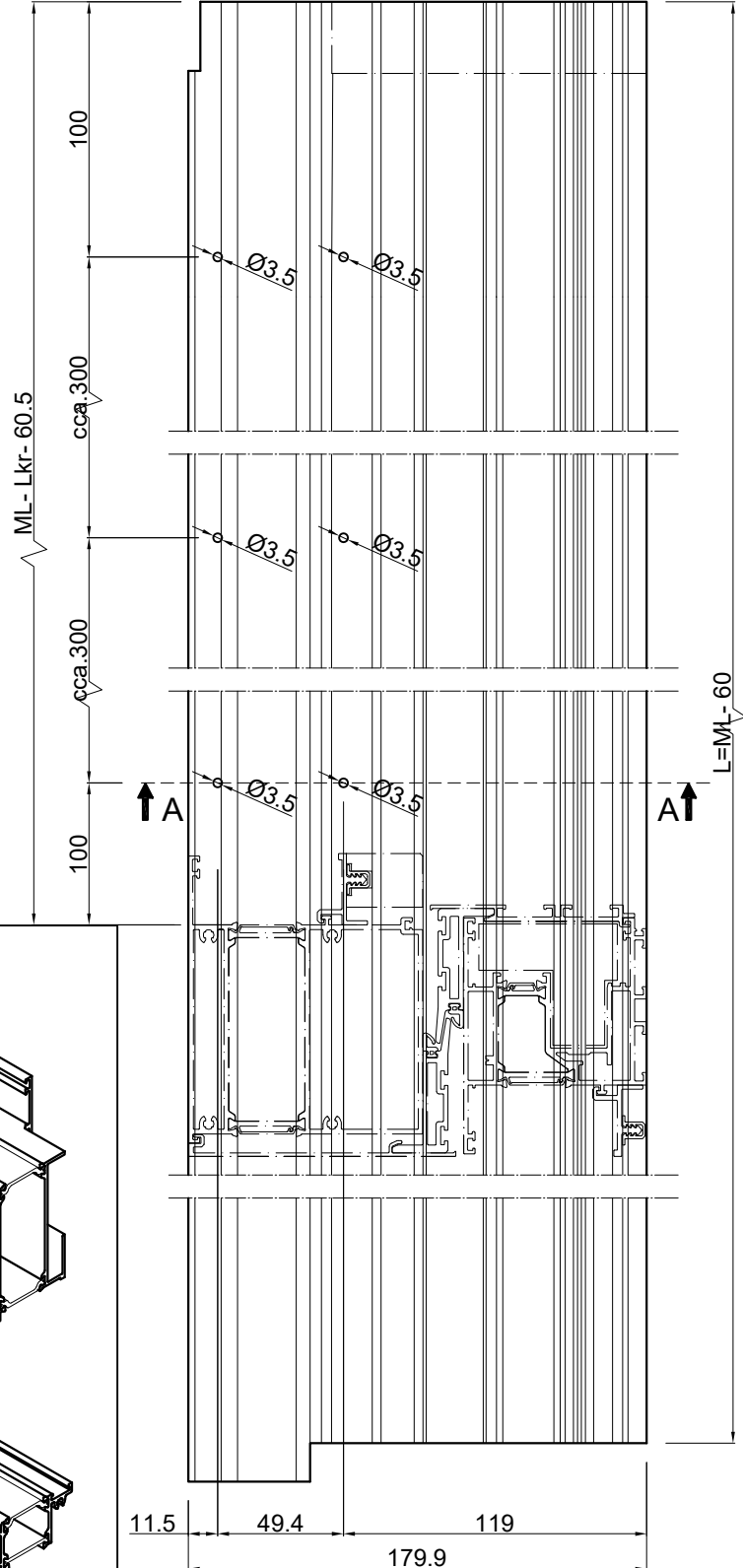
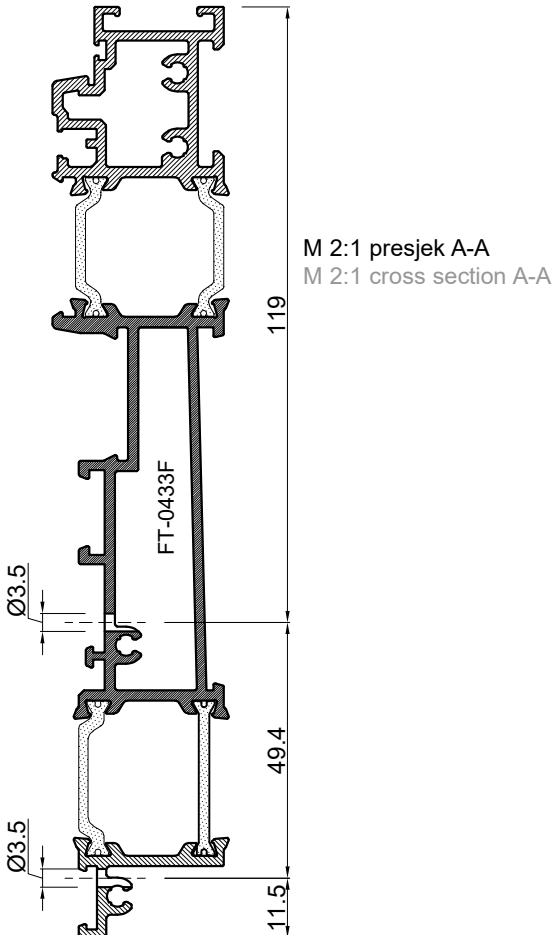
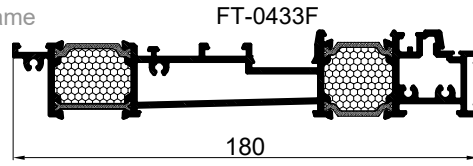

NAPOMENA:
REMARK:
Moguće koristiti profil FT-0446F kao šablon
Possible to use profile FT-0446F as template

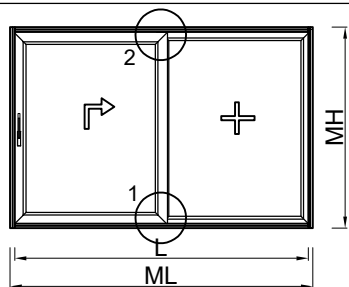

Obrada drvene obloge 600.016
Processing wooden coverings 600.016 with cutting

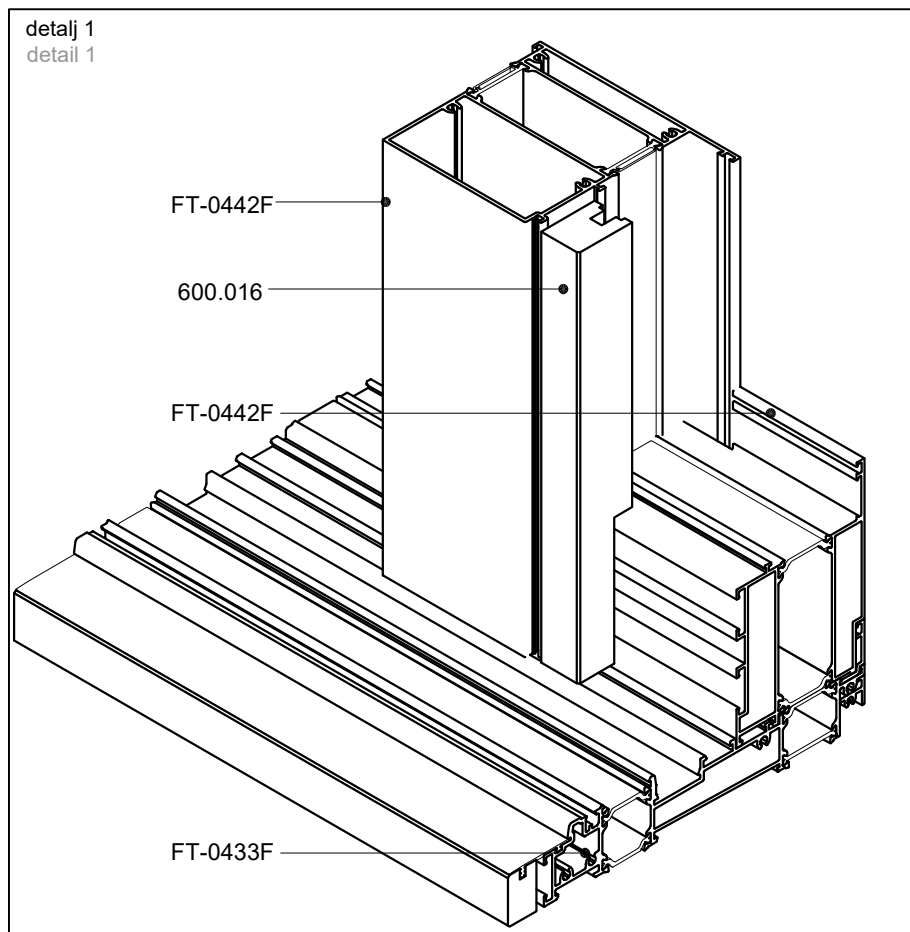
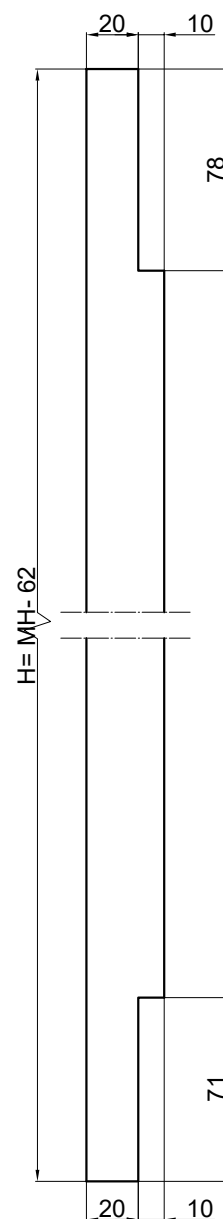
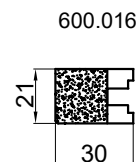
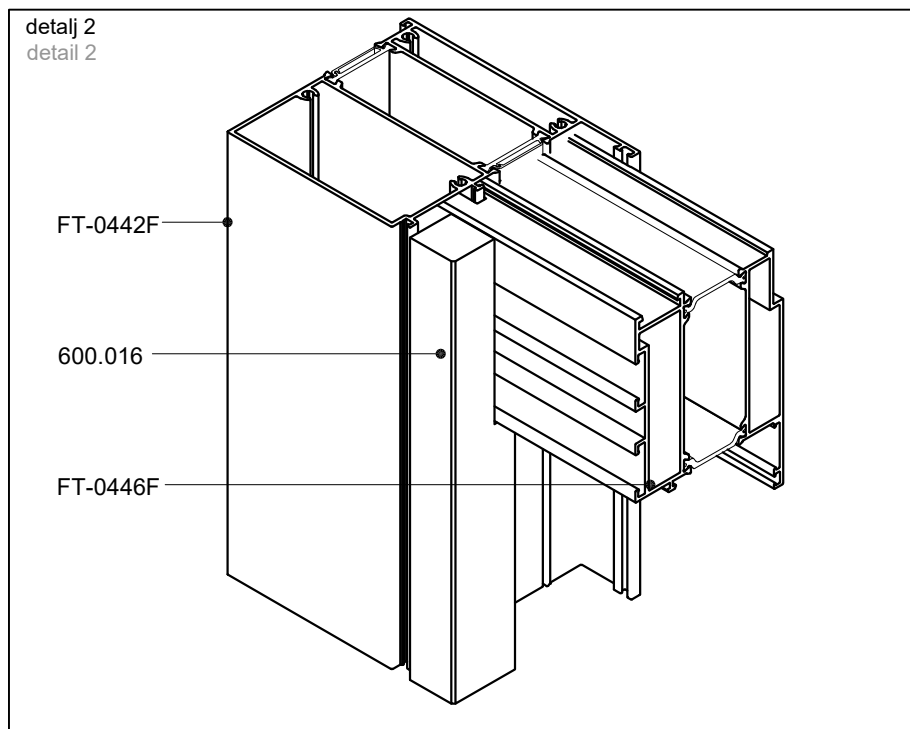

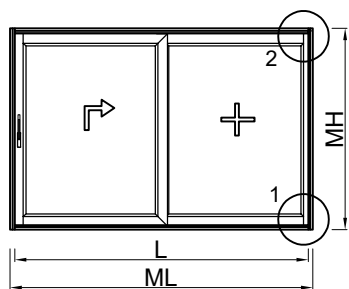

Obrada drvene obloge 600.018
Processing wooden coverings 600.018 with cutting

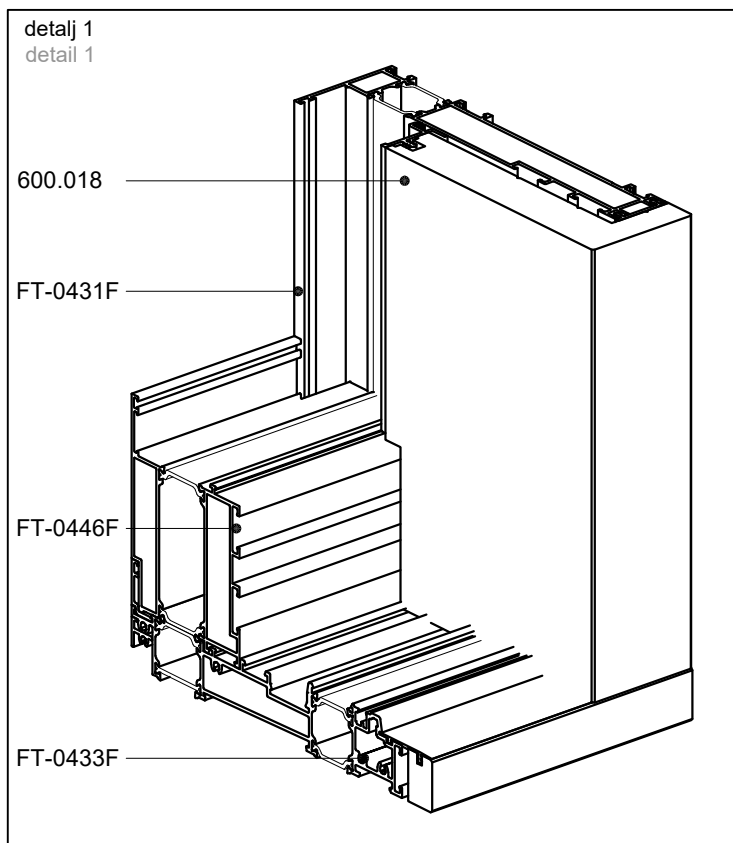
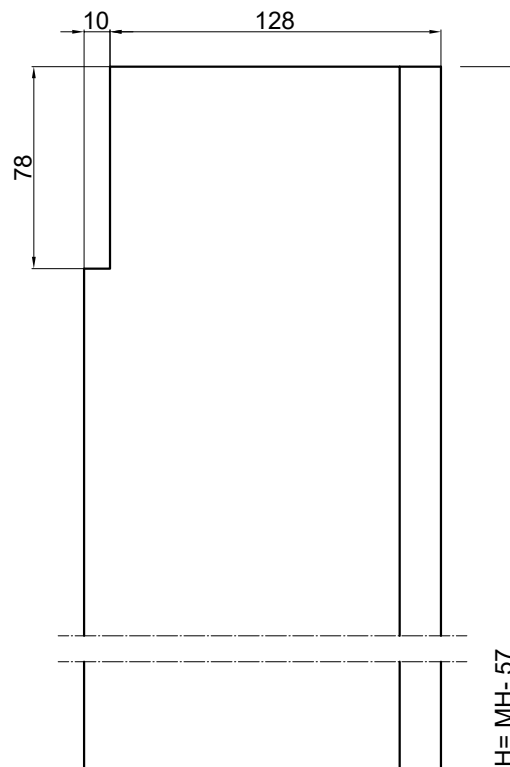
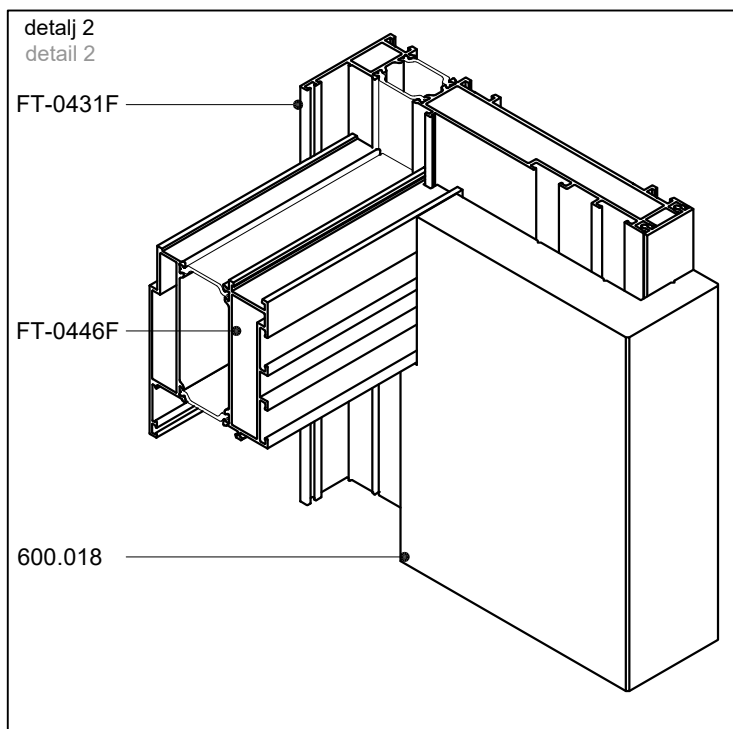
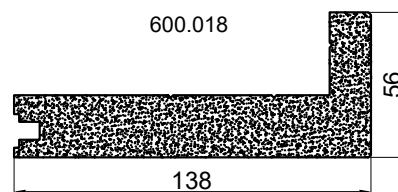

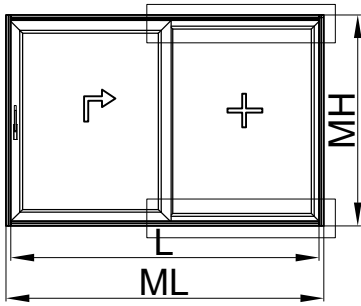

det.2
montaža drvene obloge 600.030 na profil FT-0446F
mount wooden covering 600.030 on profile FT-0446F

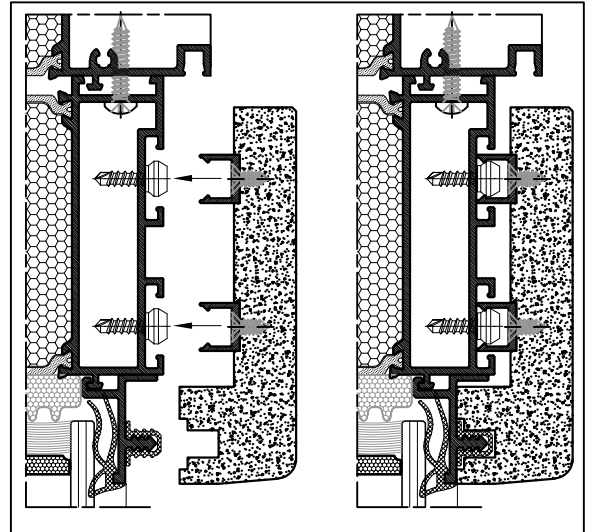

600.030
drvenu oblogu obraditi
(12.5x1.5 mm) za prihvat
profila F-1469 pomoću
vijaka 433.202
processing wooden covering
(12.5x1.5 mm) for mount
profile F-1469 with screws
433.202

det.1
montaža drvene obloge 600.030 na profil FT-0446F
mount wooden covering 600.030 on profile FT-0446F

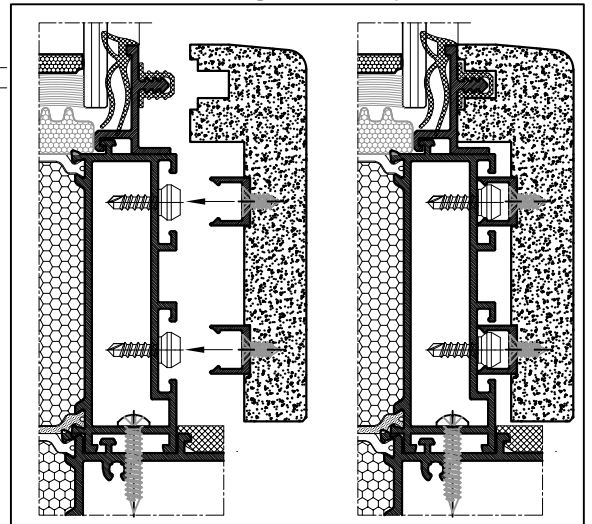

600.030
drvenu oblogu obraditi
(12.5x1.5 mm) za prihvat
profila F-1469 pomoću
vijaka 433.202
processing wooden covering
(12.5x1.5 mm) for mount
profile F-1469 with screws
433.202

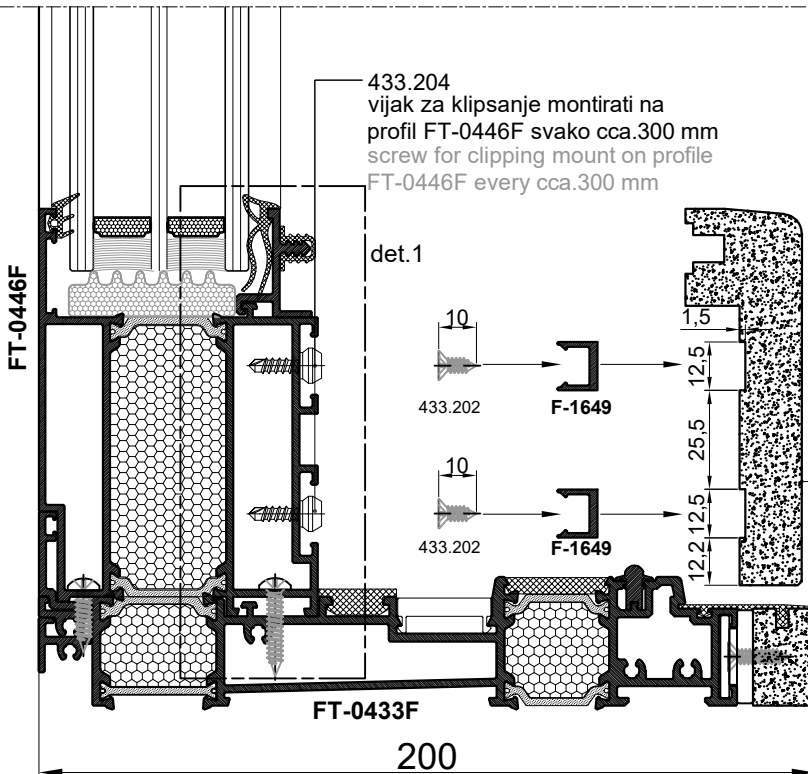
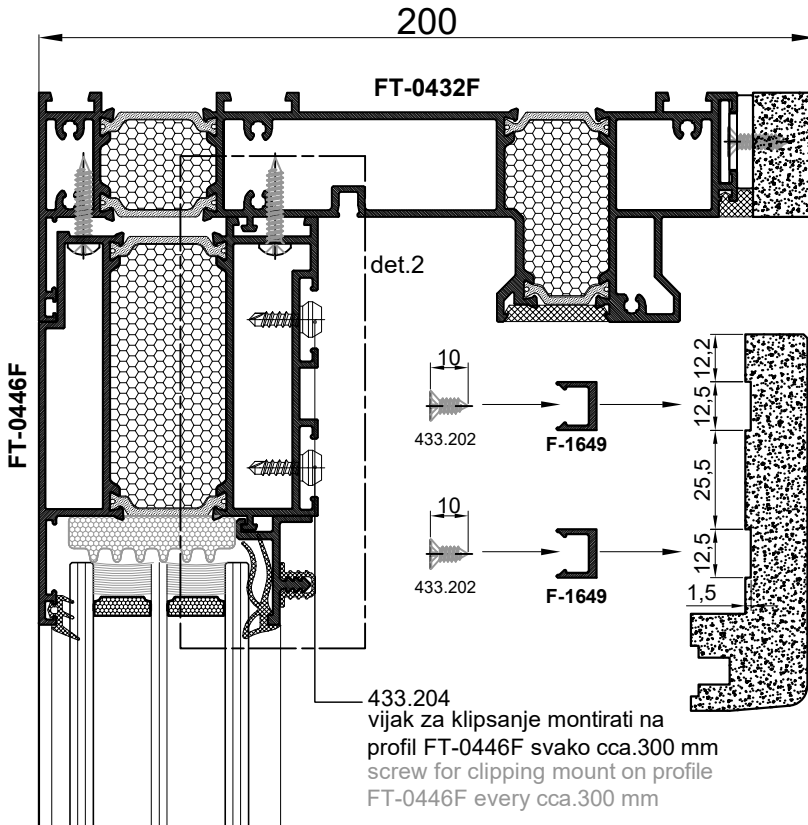

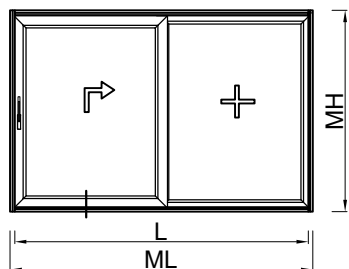

presjek A-A
cross section A-A

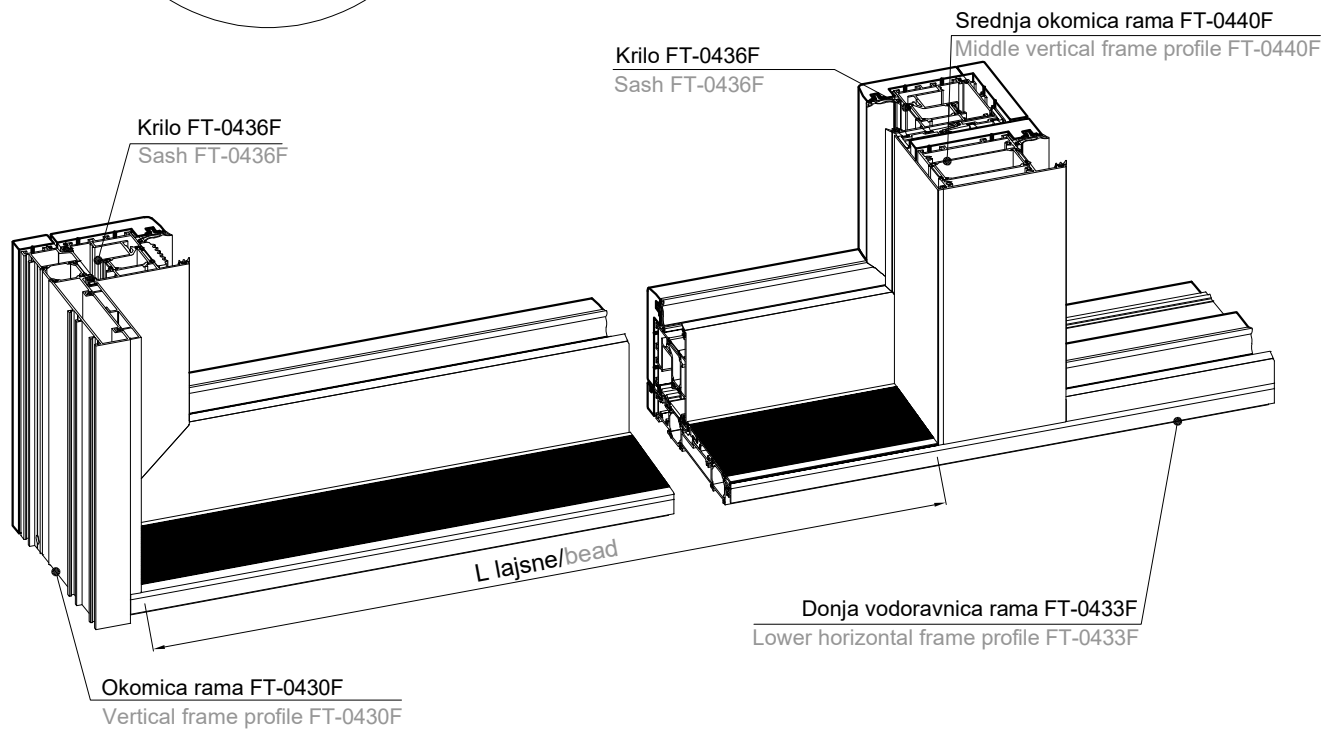
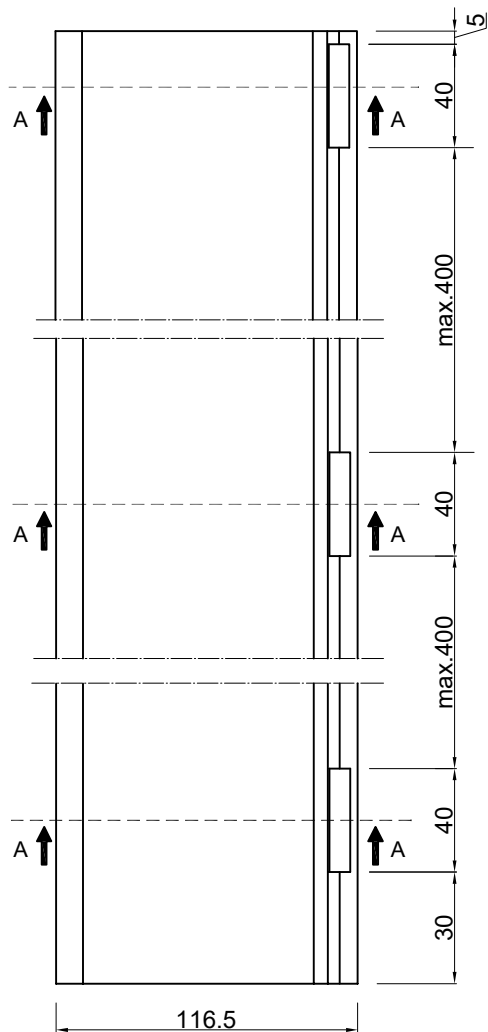
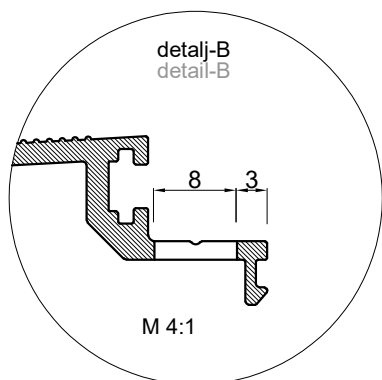
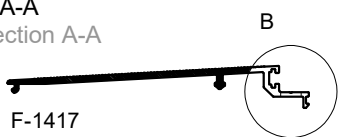

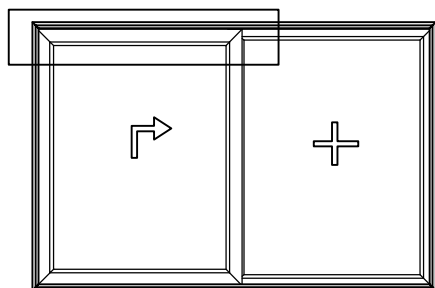

Pogled izvana
Outside view

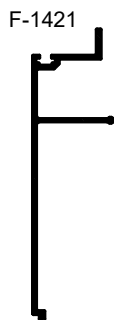

F-1421

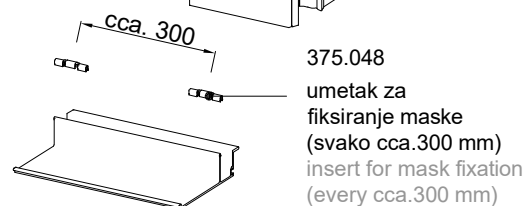
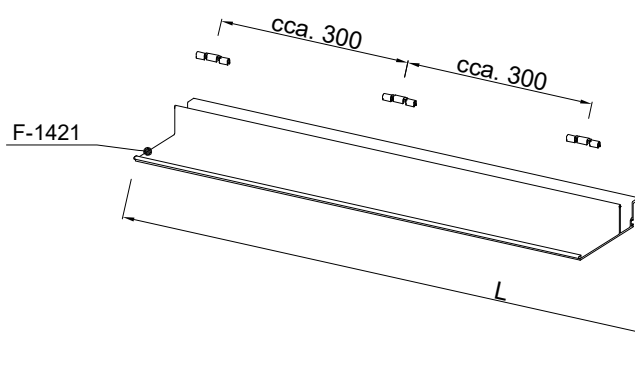
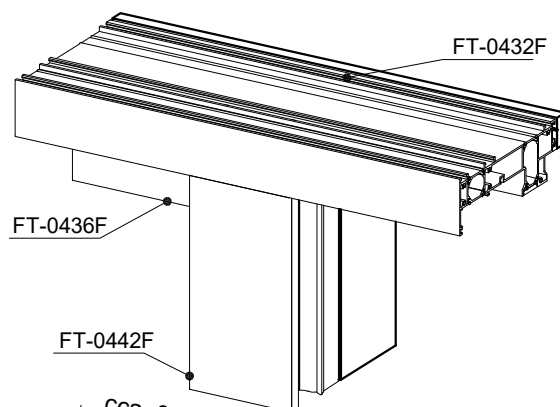
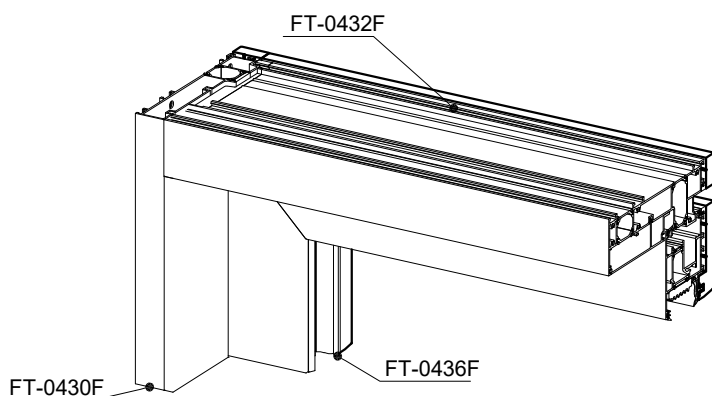
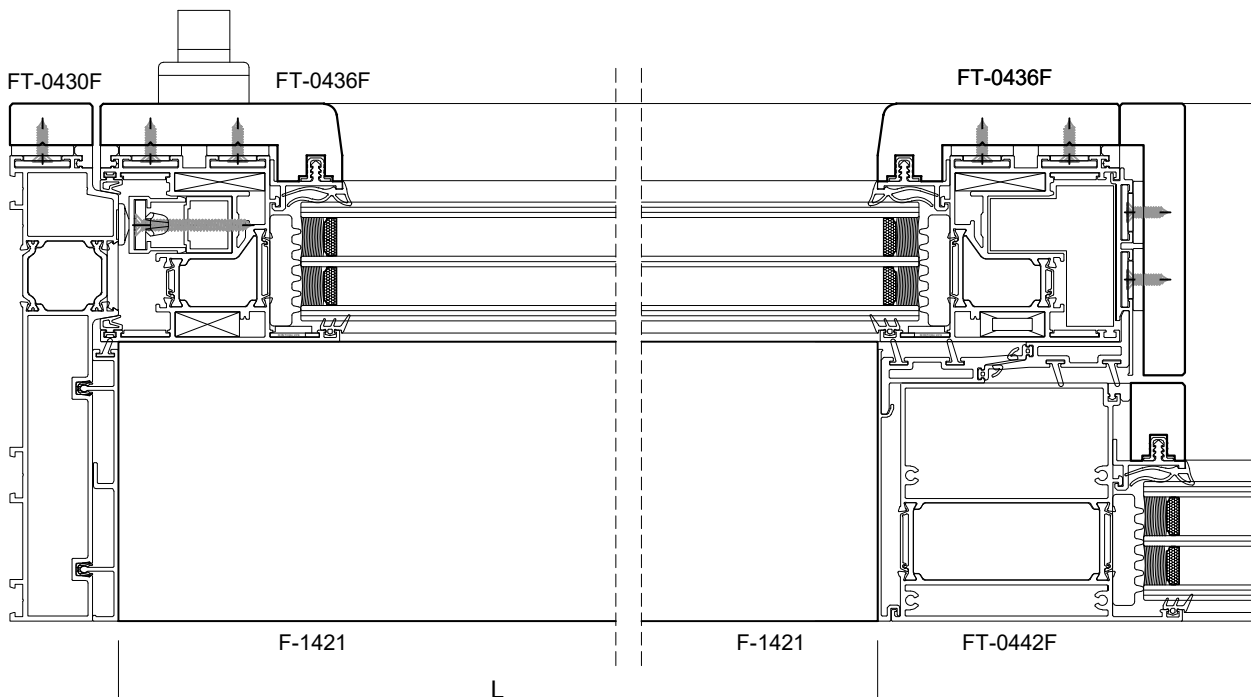

375.048
umetak za
fiksiranje maske
(svako cca.300 mm)
insert for mask fixation
(every cca.300 mm)

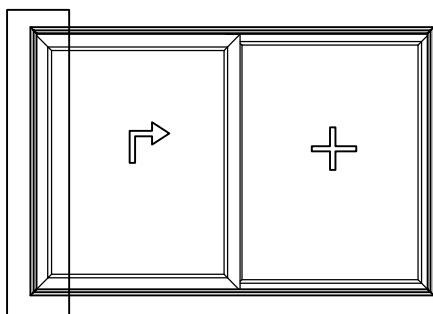

Pogled izvana
Outside view

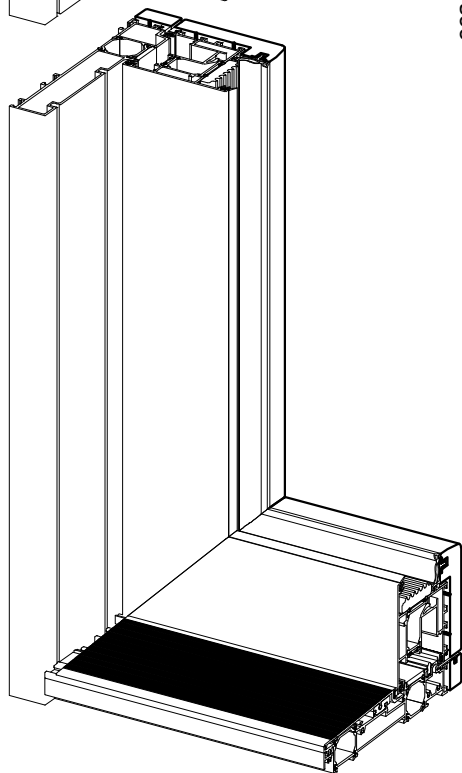
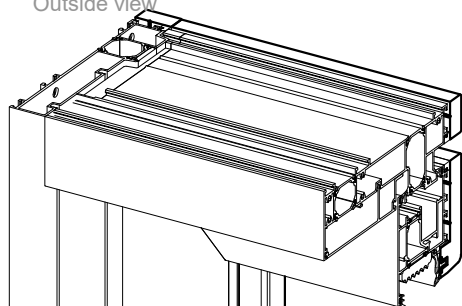

375.048
umetak za
fiksiranje maske
(svako cca.300 mm)
375.048
insert for mask fixation
(every cca.300 mm)

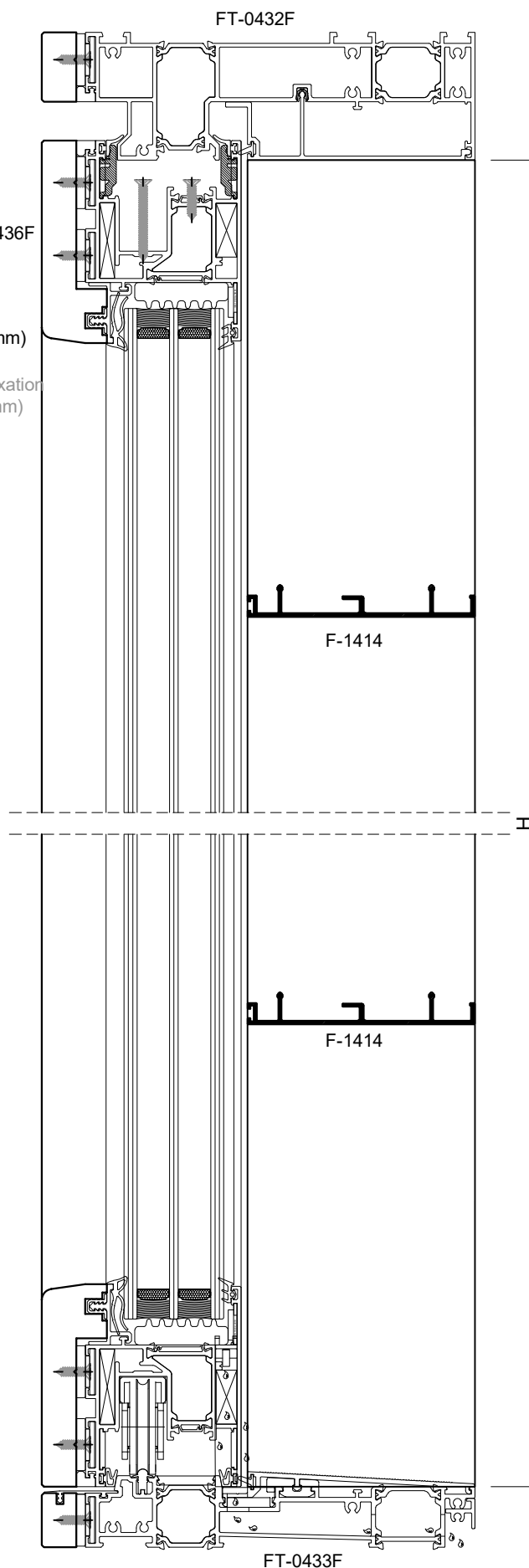
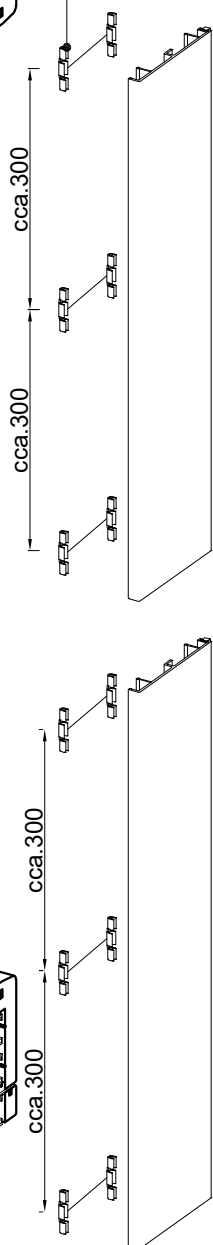

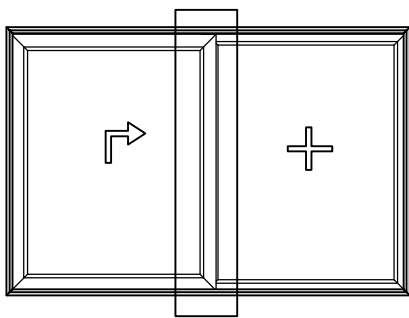

Pogled izvana
Outside view

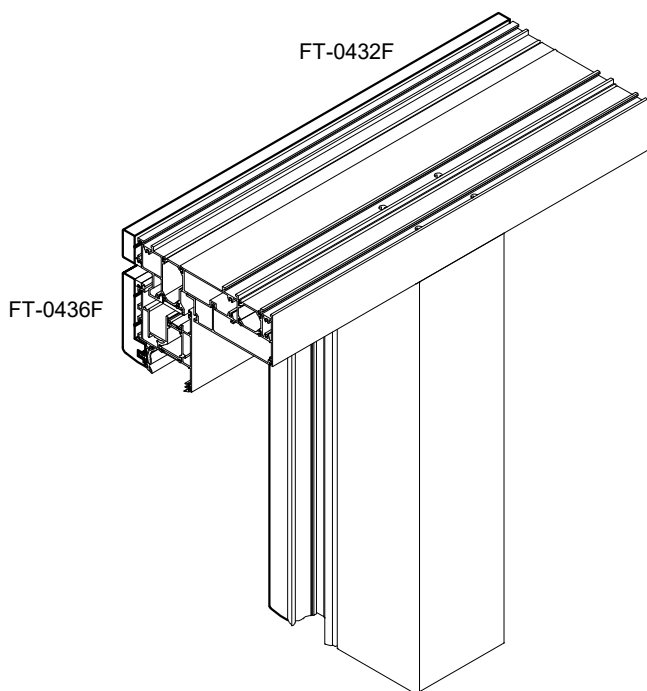

FT-0432F

FT-0436F

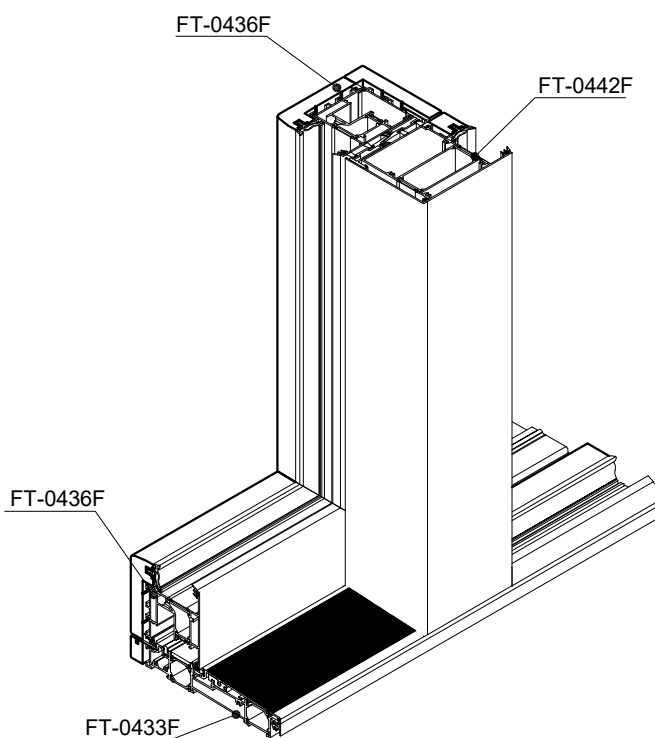

FT-0436F

FT-0442F

FT-0436F

FT-0433F

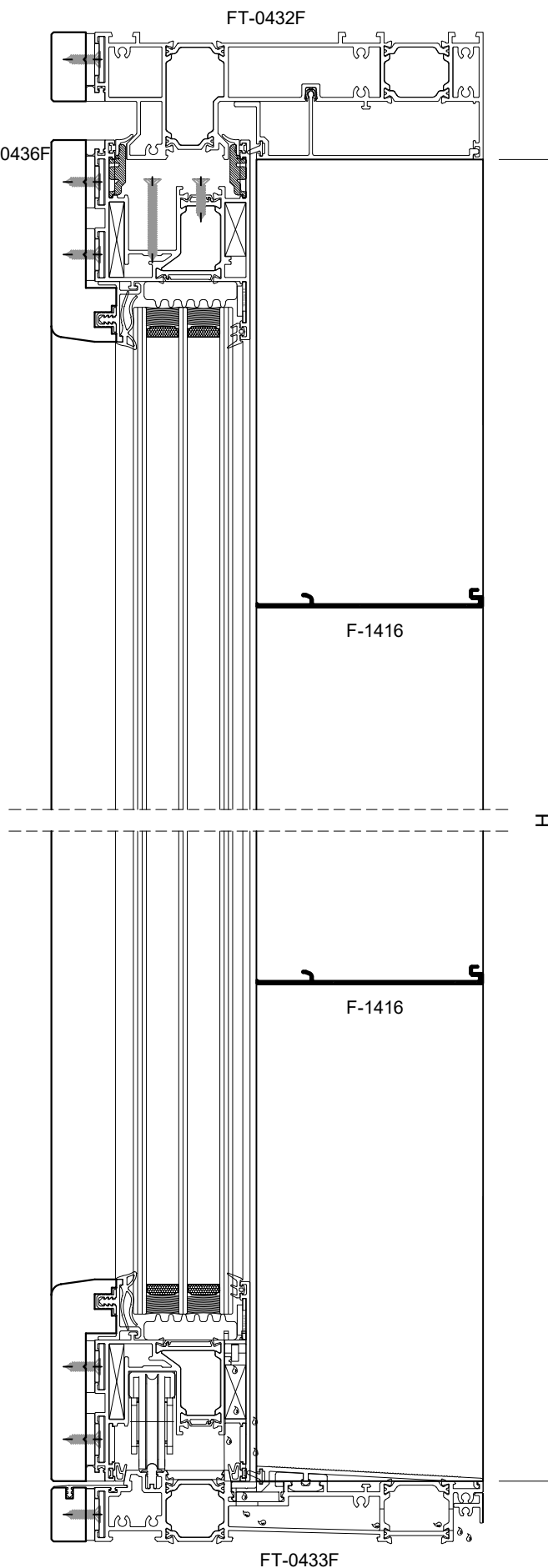

FT-0432F

FT-0436F

F-1416

F-1416

FT-0433F

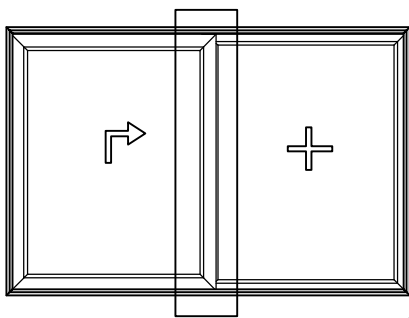

Pogled izvana
Outside view

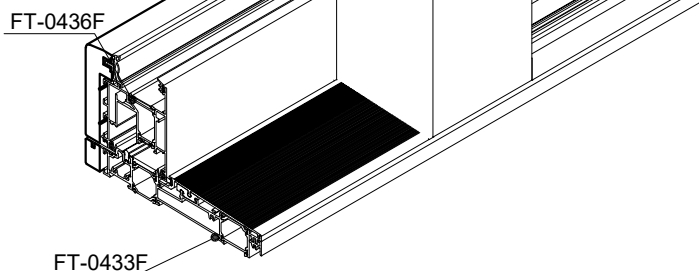
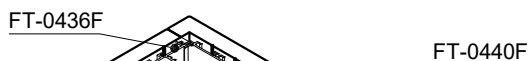
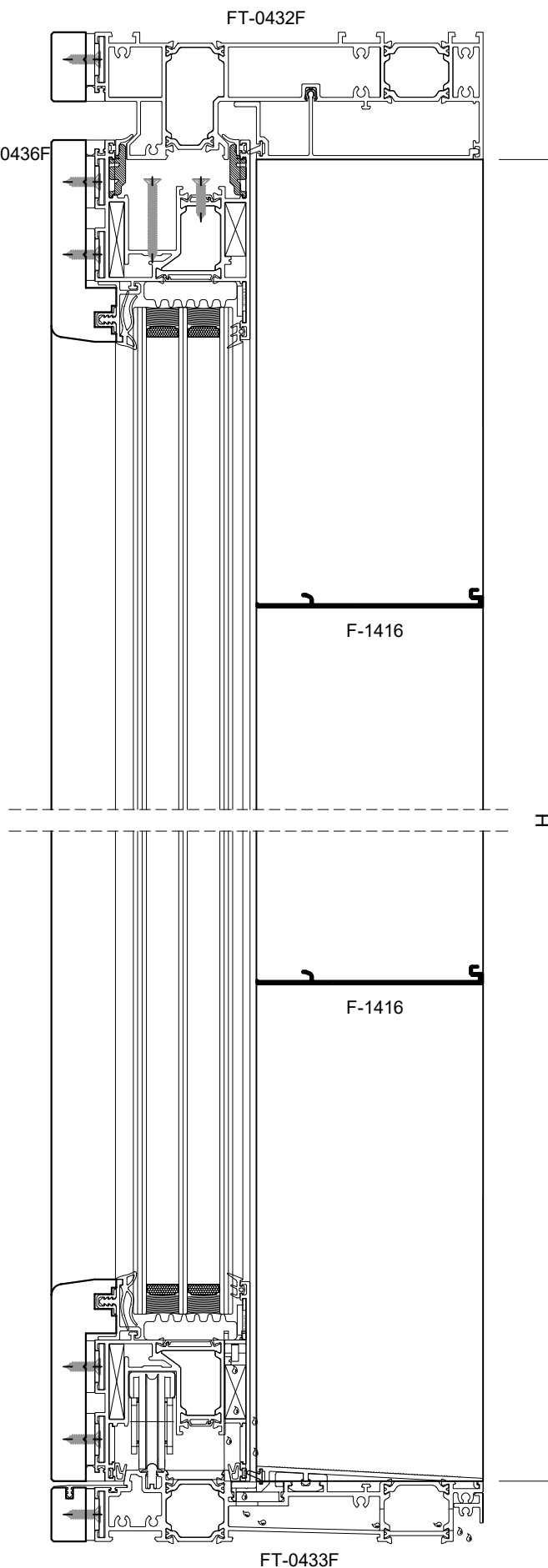
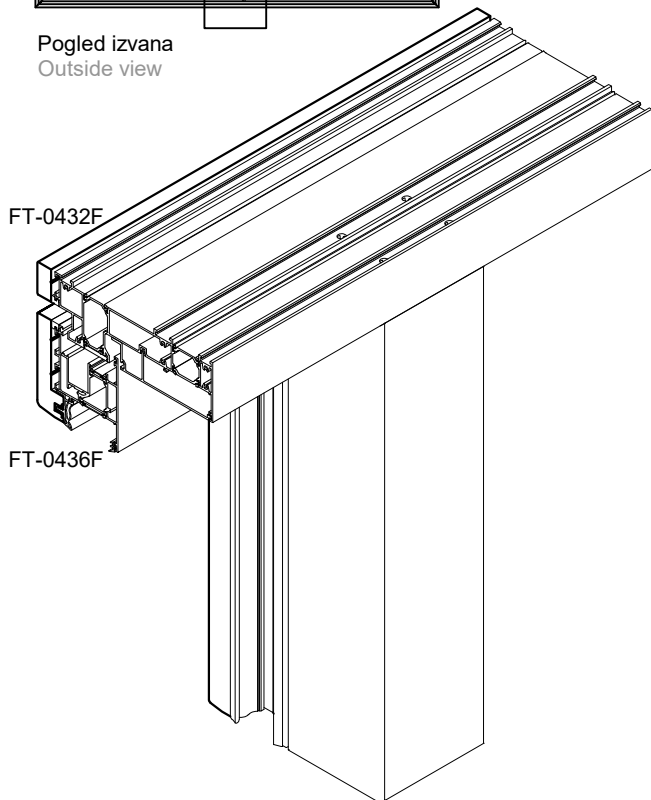

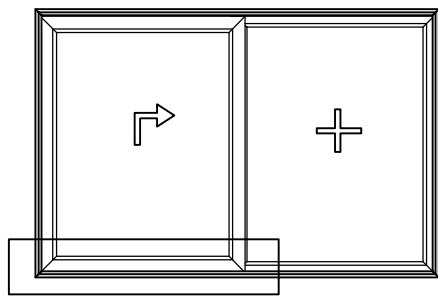

Pogled izvana
Outside view

F-1417

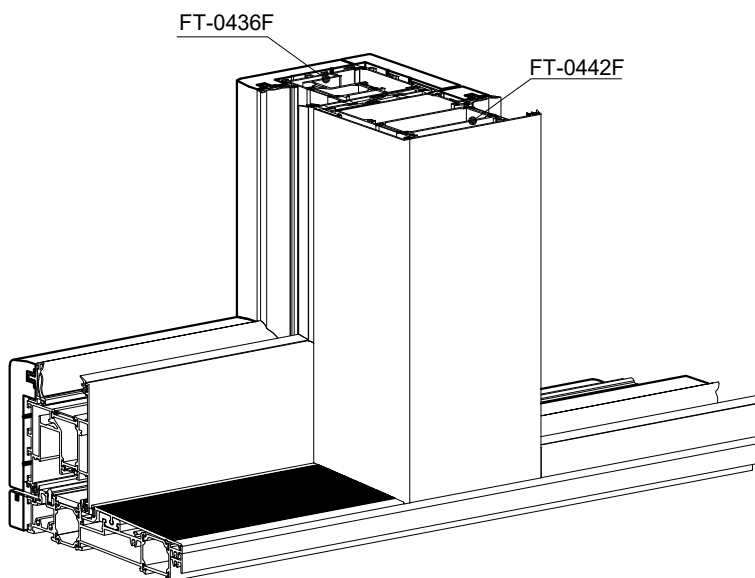
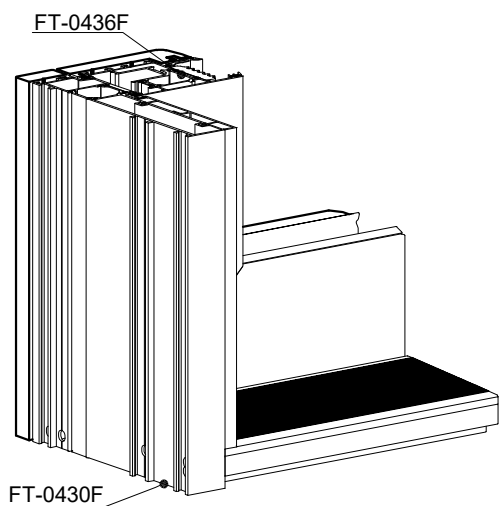
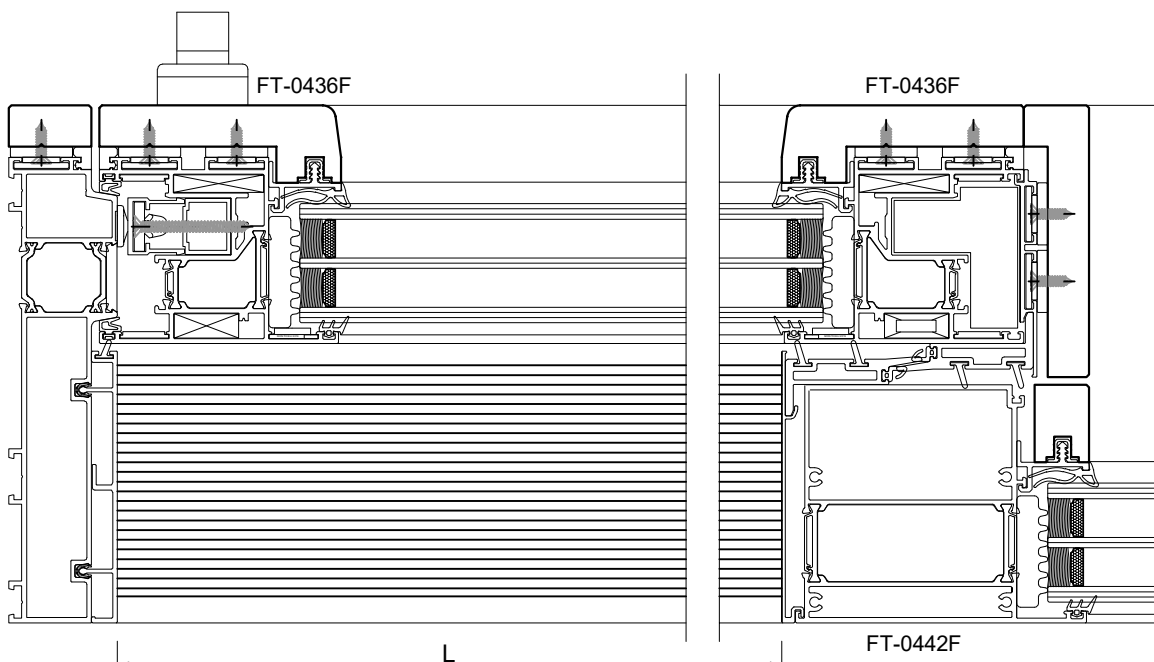
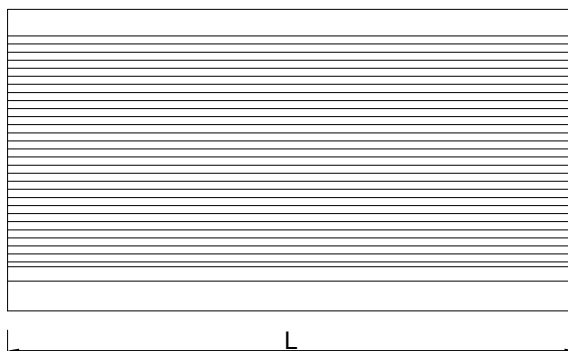

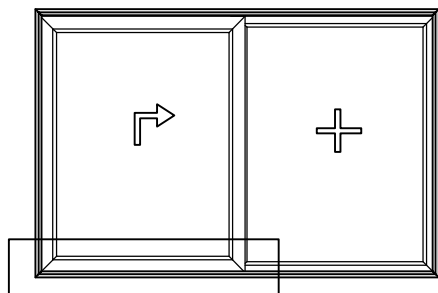

Pogled izvana
Outside view

F-1417

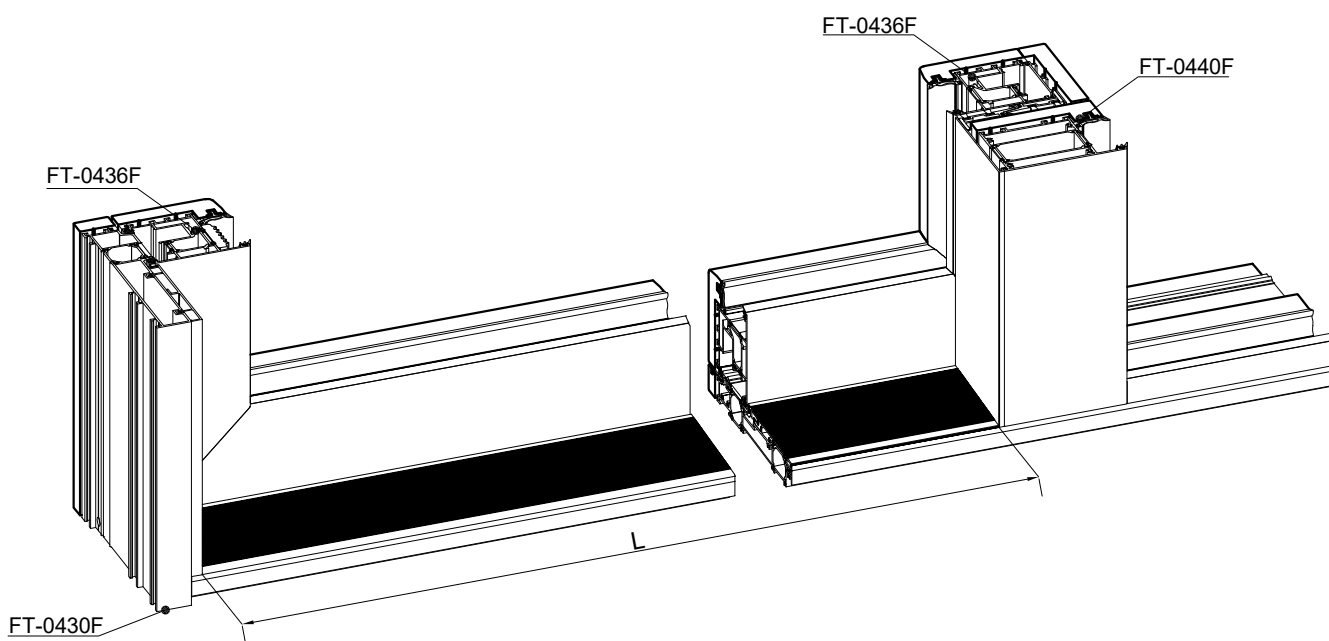
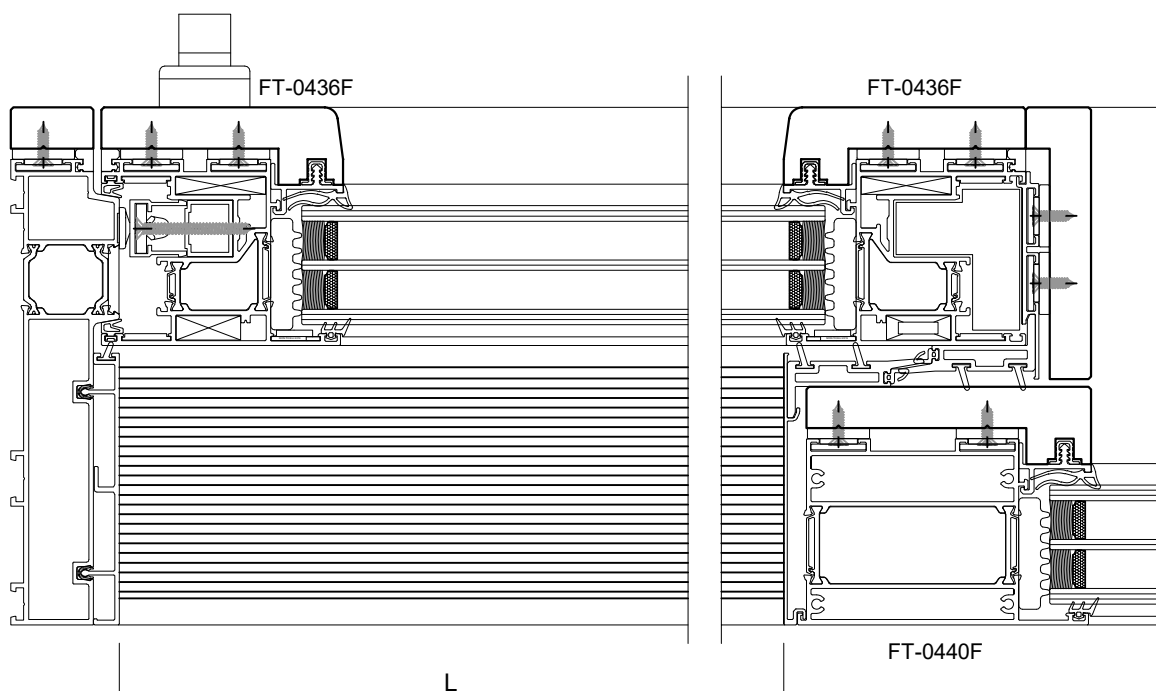
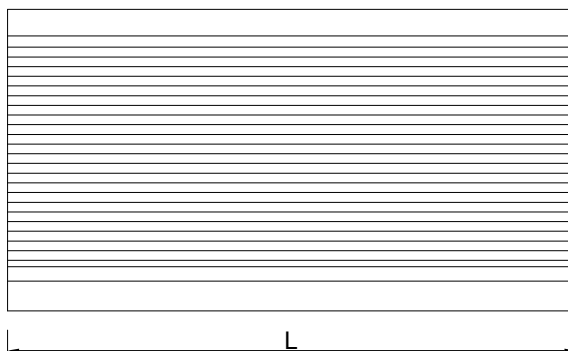

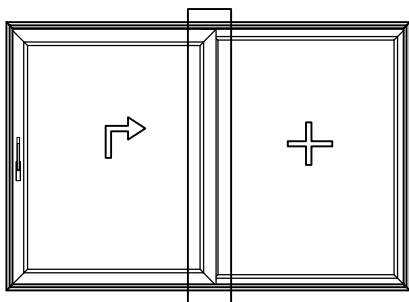

- Obrada profila maske F-1415 zapilavanjem.
- Processing mask profile F-1415 with cutting.

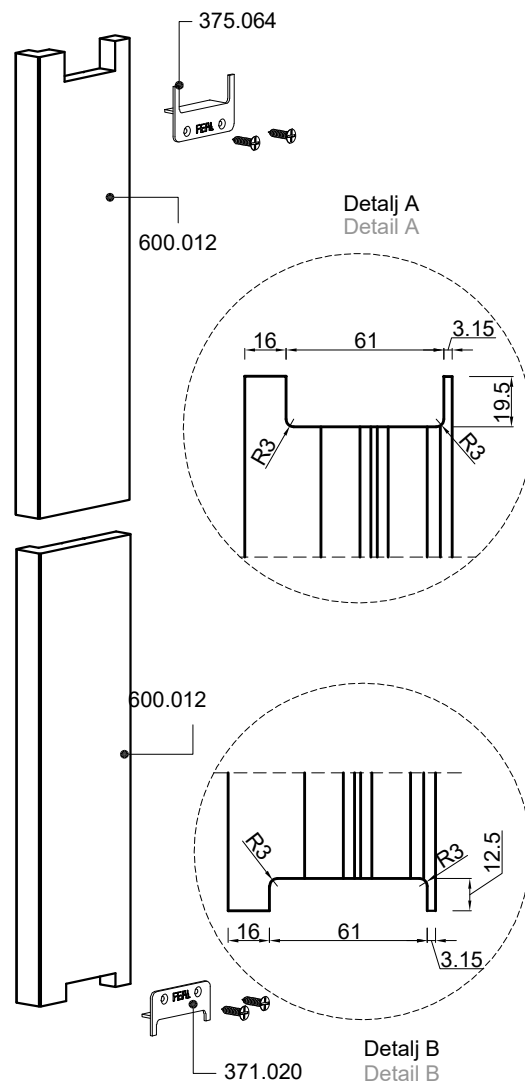
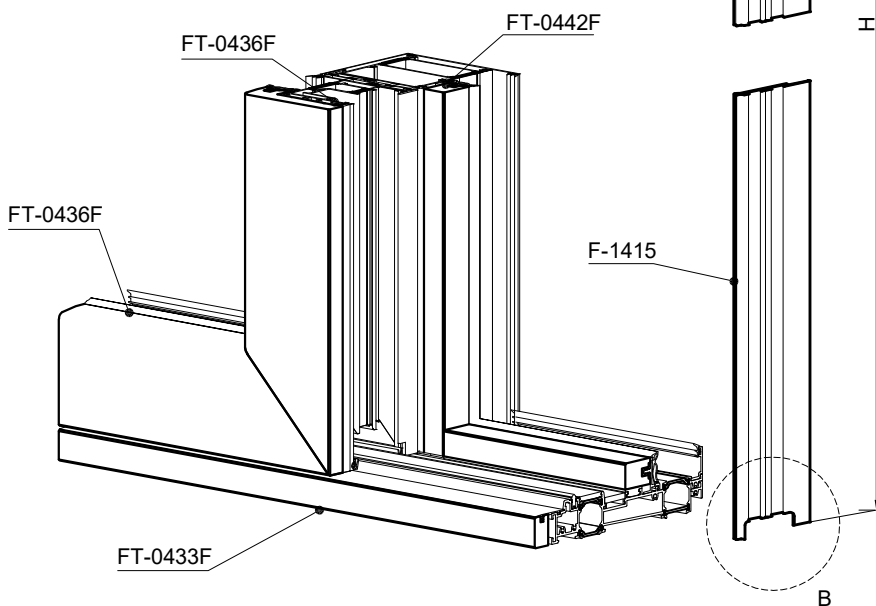
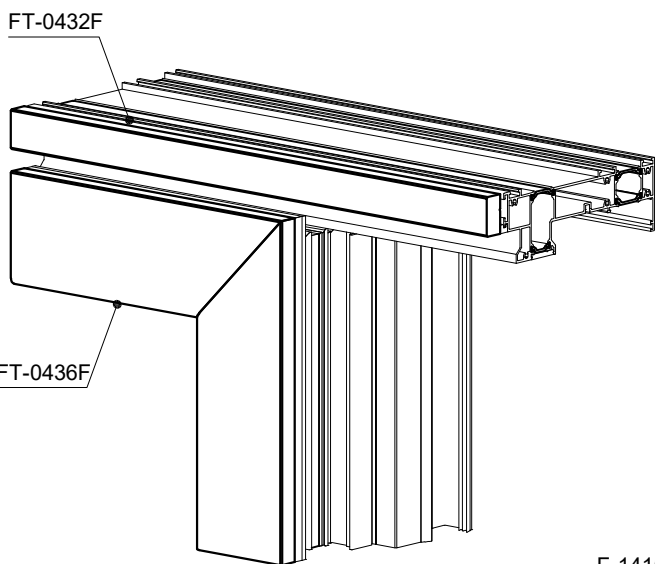
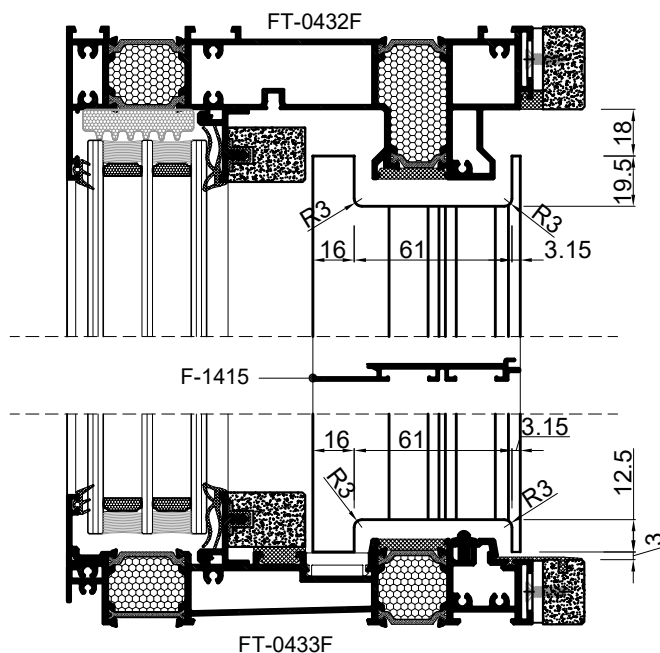

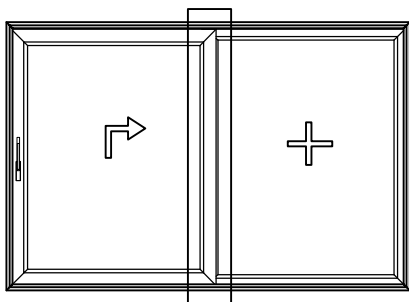

- Obrada profila drvene maske 600.012 zapilavanjem.
- Processing wooden mask profile 600.012 with cutting

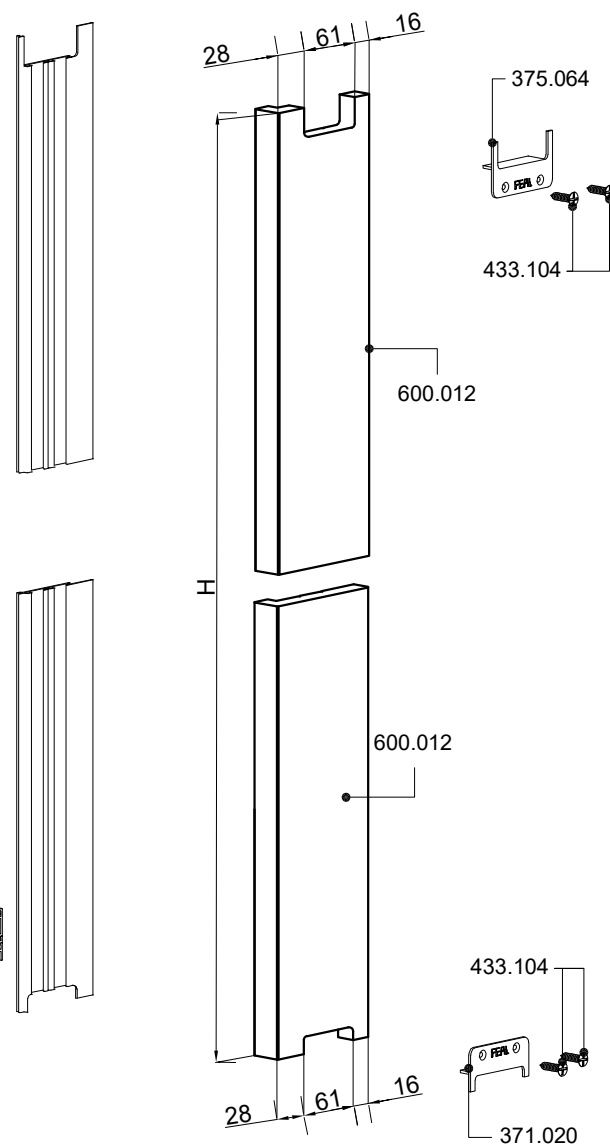
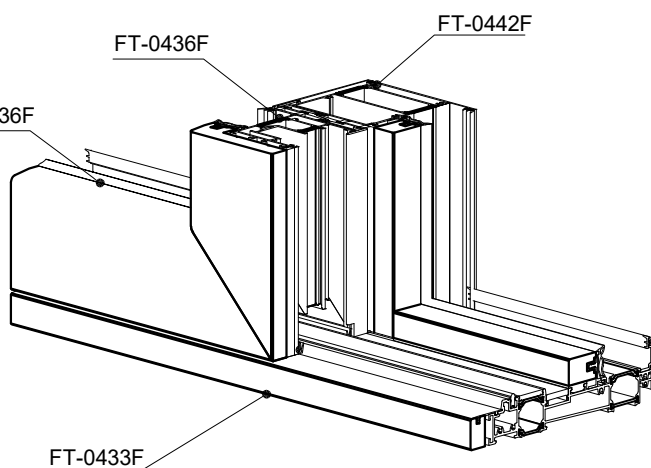
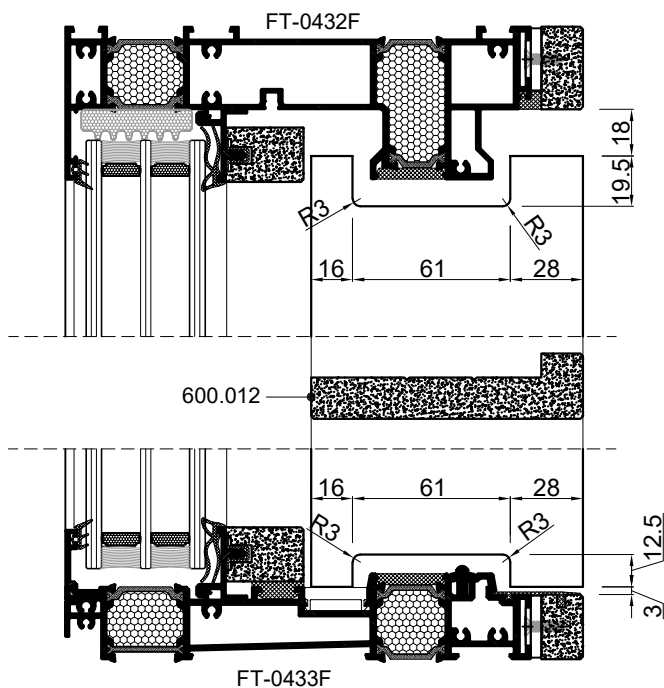
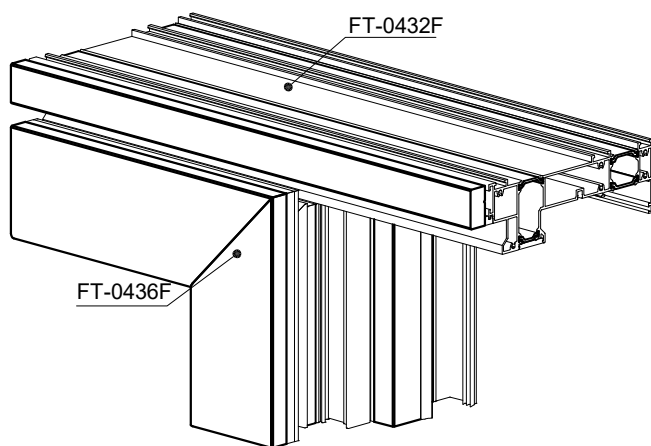

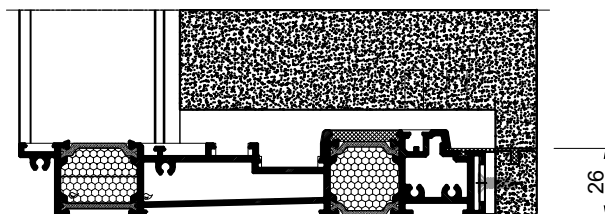
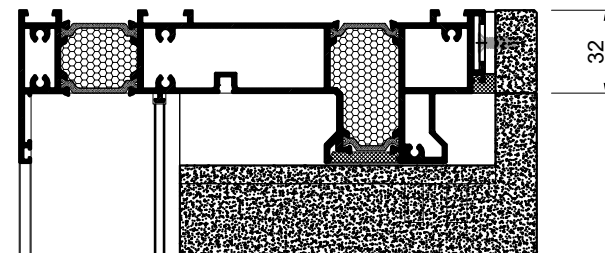
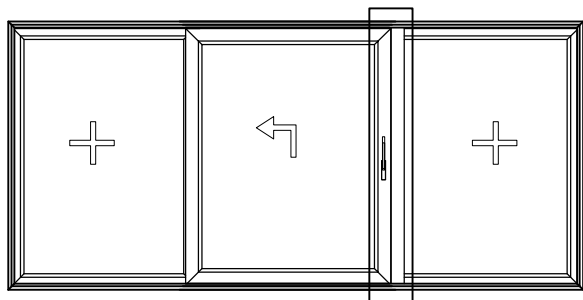

- Obrada drvene obloge 600.018 zapilavanjem.
- Processing wooden coverings 600.018 with cutting.

FT-0432F

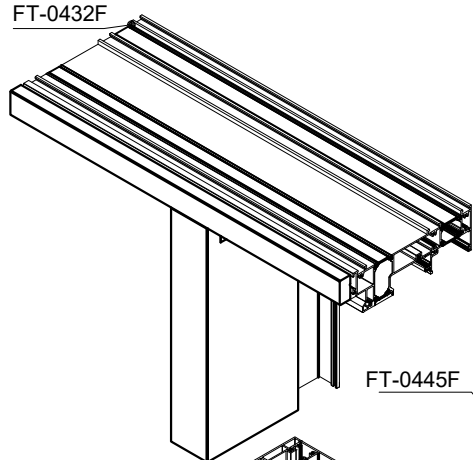

FT-0445F

FT-0445F

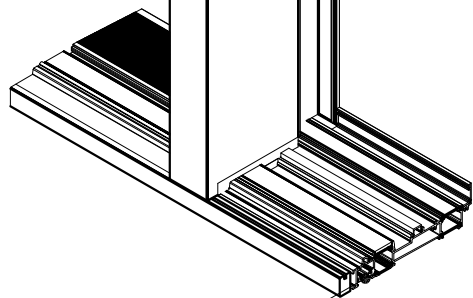

FT-0433F

FT-0445F

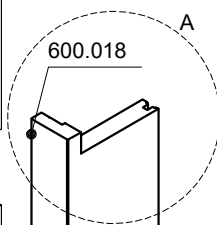

600.018

A

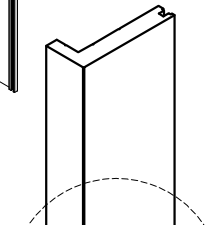

600.018

B

Detalj A
Detail A

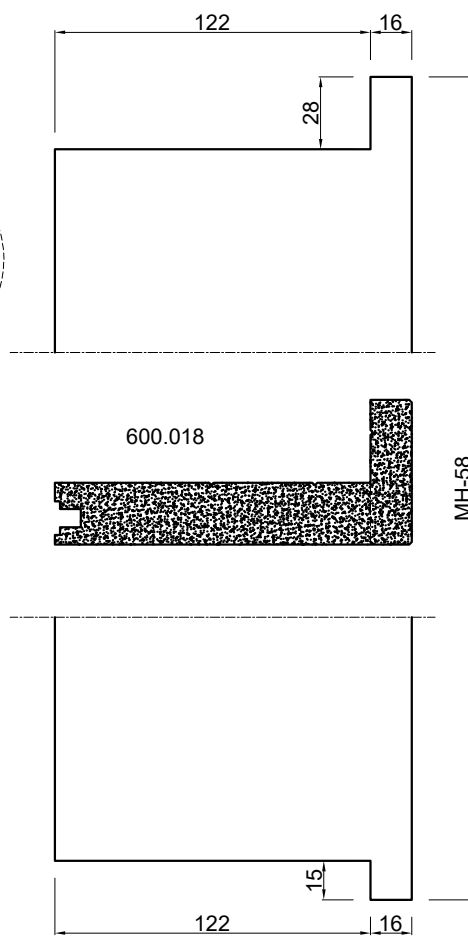

Detalj B
Detail B

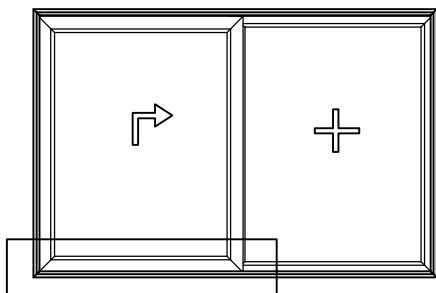

Pogled izvana
Outside view

UGRADNJA UBLAŽIVAČA UDARA KRILA 345.010:

- koristi se kod dvokrilnog i četverokrilnog podizno kliznog s fiksnim dijelom
- ugrađuje se na krilo, simetrično gore i dolje

INSTALLATION OF SASH BUFFER 345.010:

- is used by two and four sash lift and slide window with fixed part
- is mounted onto sash, symmetrically up and down

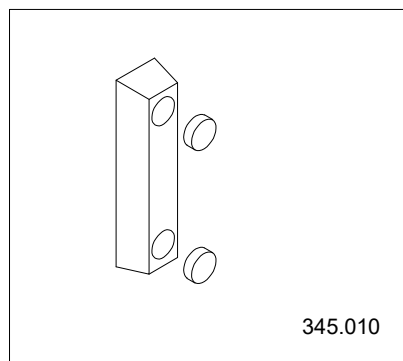
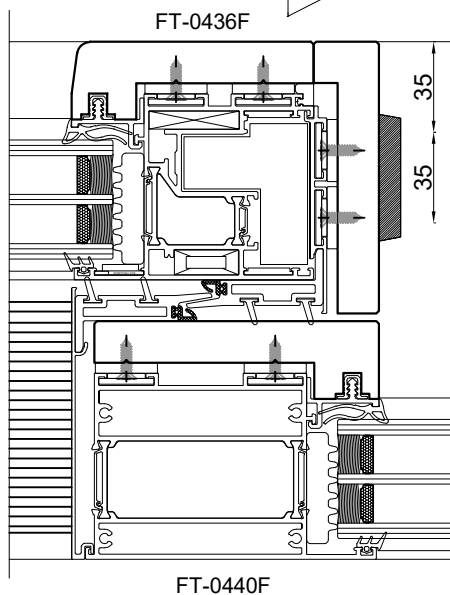
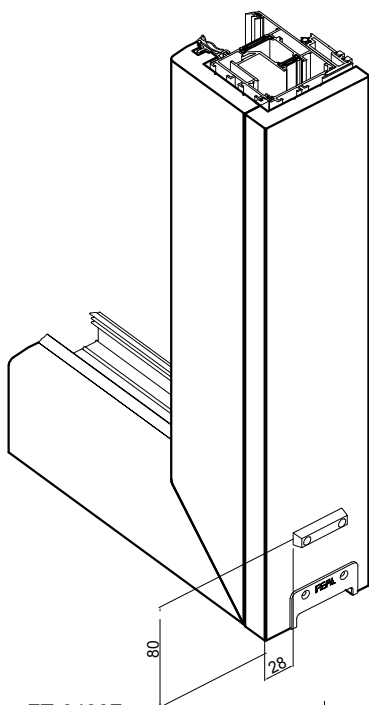
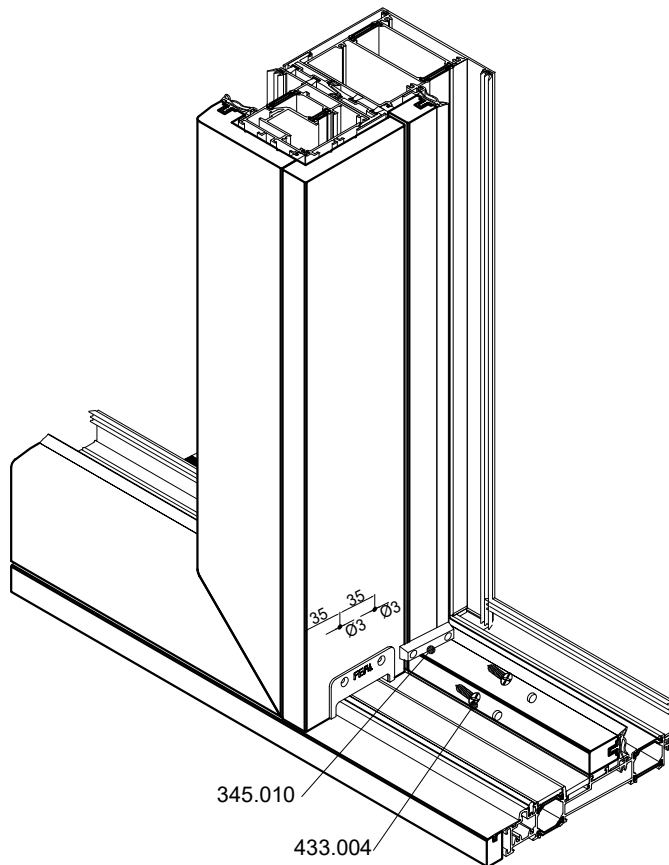

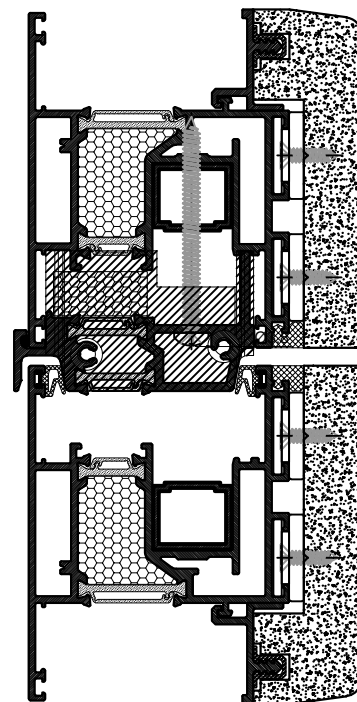
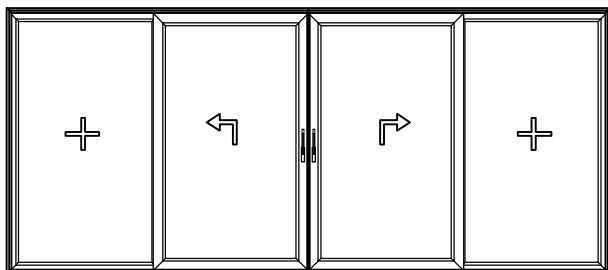

- Ugradnja i obrada profila FT-0441 za spoj četverokrlnog
- Ugradnja čepa 363.030
- Montage and processing of profile FT-0441 for four sash joint
- Cap installation 363.030

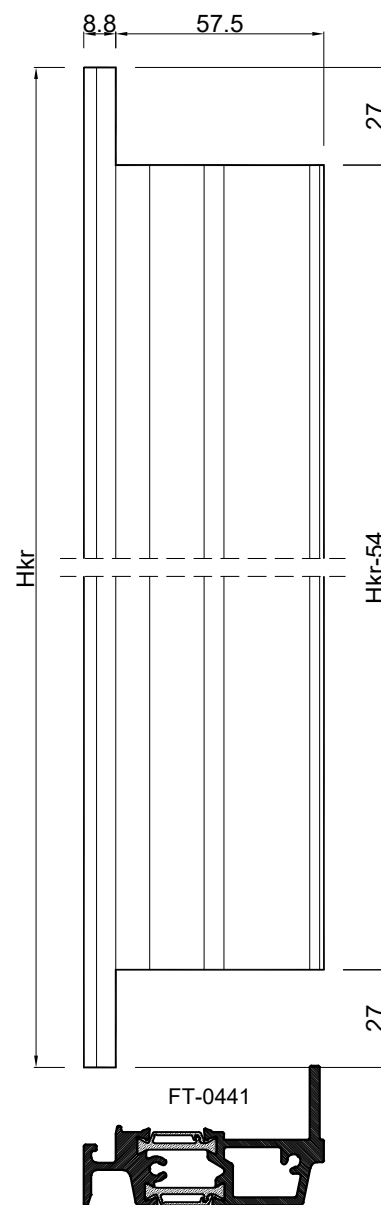
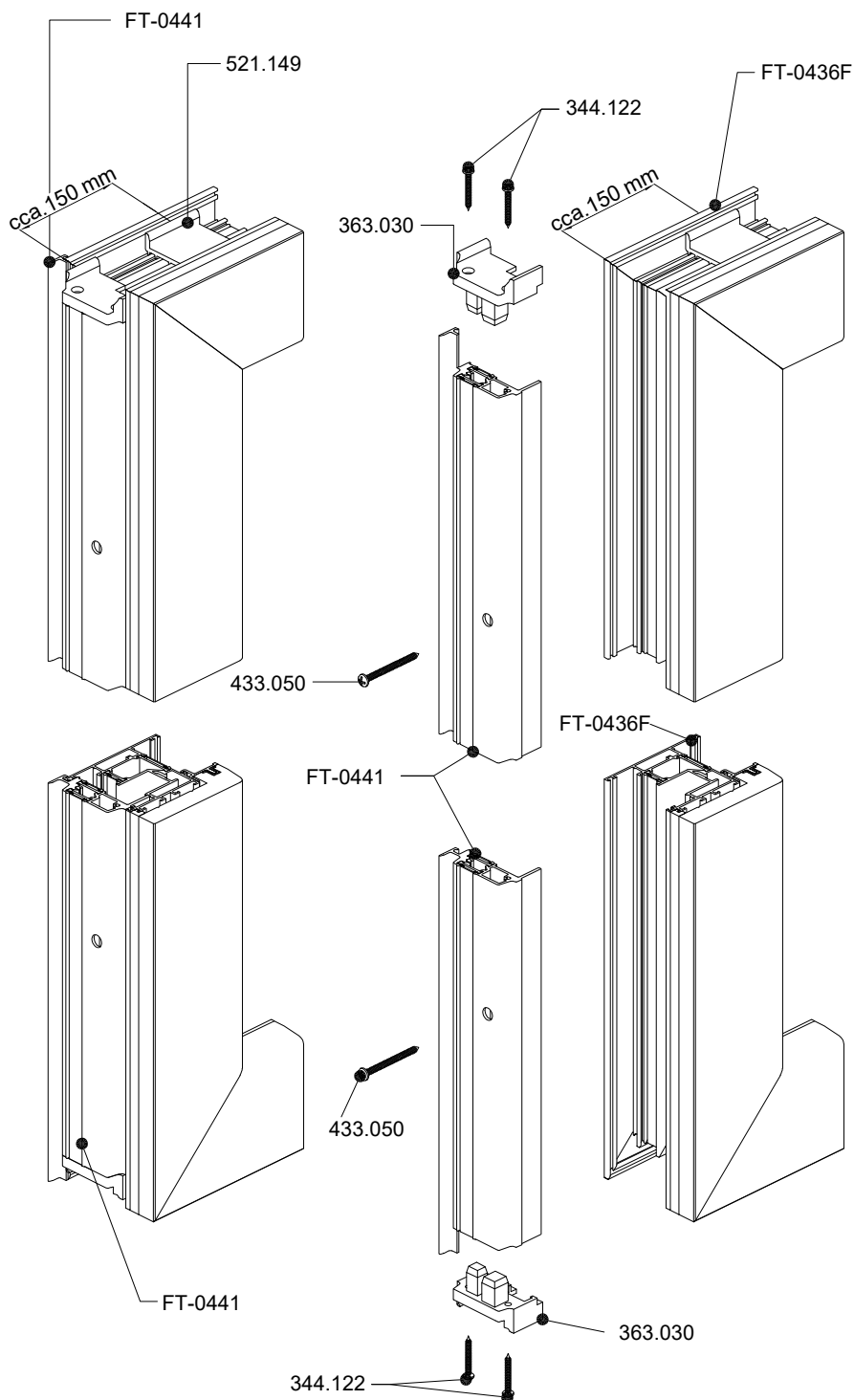

- Obrada profila krila za skriveni odvod kapljevina
- Processing sash profile for hidden drainage
- Obrada na profilu krila FT-0436F za odvod kapljevina.
- Processing on sash profile FT-0436F for drainage.

Obrada profila se izvodi na:

Processing profile is done on:

Univerzalna glodalica / stubna bušilica

Universal milling machine / press drill

Alat: vretenasto glodalo Ø10 / svrdlo Ø10

Tool: end mill Ø10 / bore Ø10

Kapljevina se izvode van pomoću monodrain cijevčice 360.009

Extract liquid using Monodrain tube 360.009

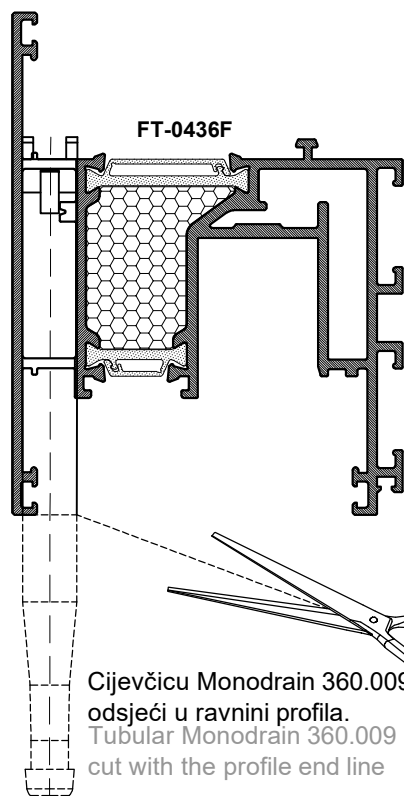
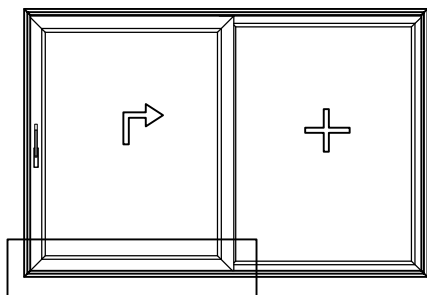

360.009

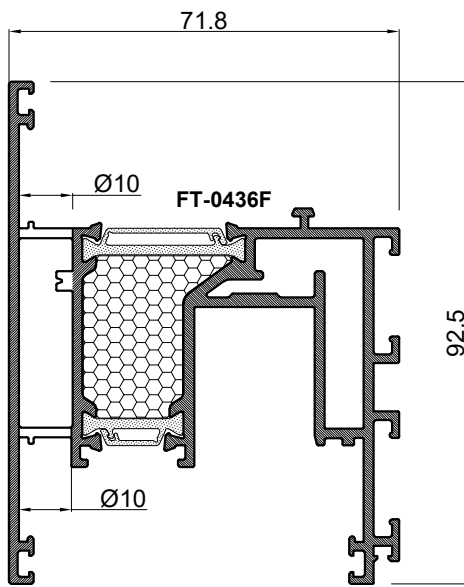

Cijevčicu Monodrain 360.009
odsjeći u ravni profila.
Tubular Monodrain 360.009
cut with the profile end line

Izvod kapljevina iz profila pomoću cijevčice Monodrain 360.009
Extract liquid from the profile using Monodrain tube 360.009

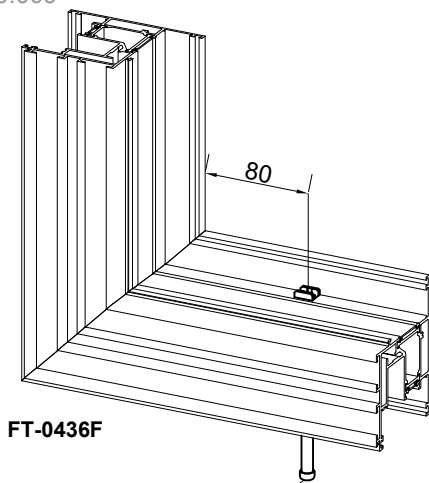

FT-0436F

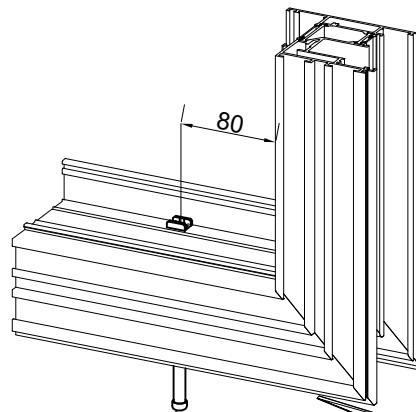
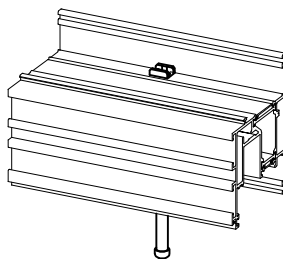

max 700

max 700

Prikaz montaže drvene obloge 600.008 na krilo FT-0436F
Display of wooden covering montage 600.008 on sash FT-0436F

375.050

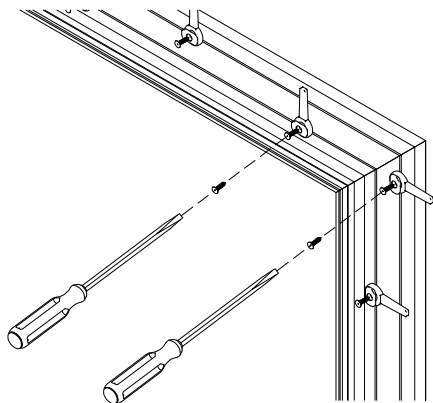
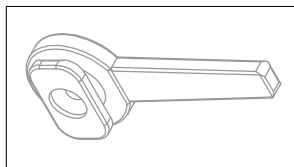

1. Montiranje kopči na drvenu oblogu pomoću vijaka
1. Montage of clamps on wooden covering with screws

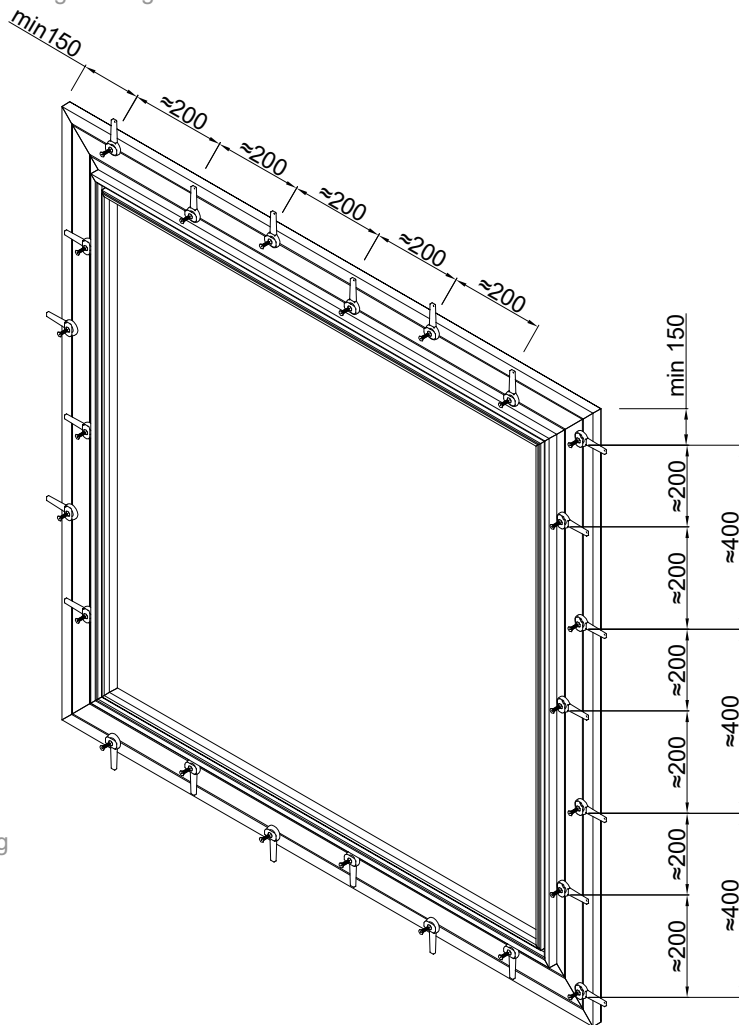

2. Rasporediti kopče po obodu drvene obloge s pravilnim razmacima u položaju otključano
2. Arrange clamps along covering edge with equal spacing in position unlocked

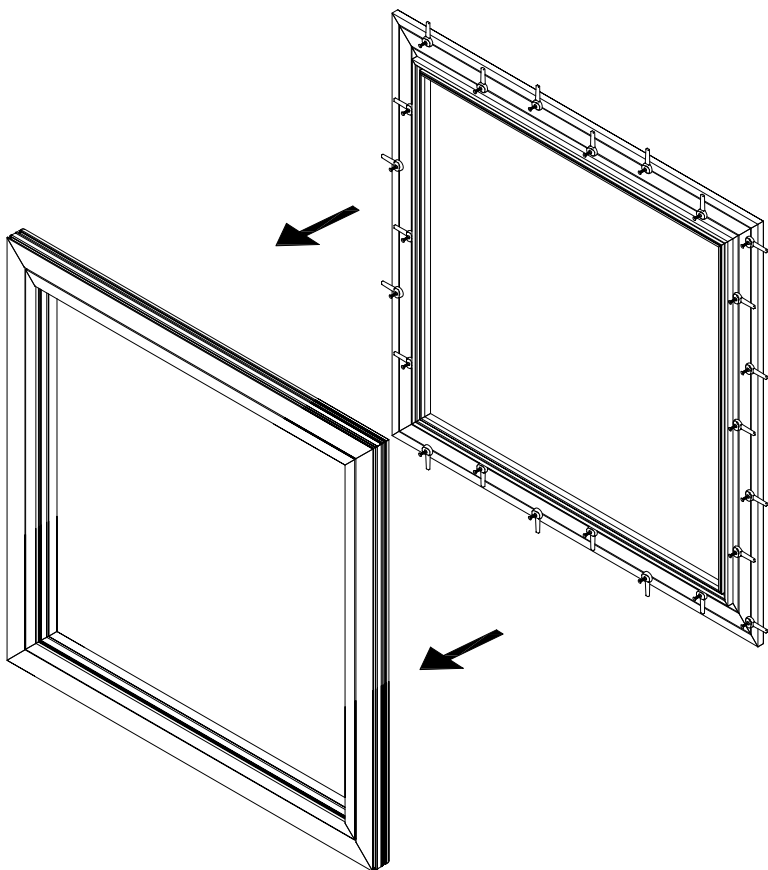

3. Postaviti drvenu oblogu na krilo
3. Place wooden covering onto sash

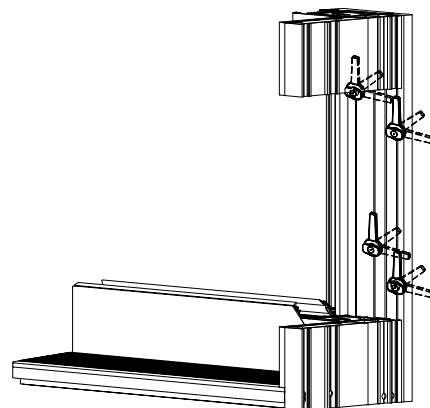

4. Postaviti kopče u položaj zaključano
4. Place clamps in position locked

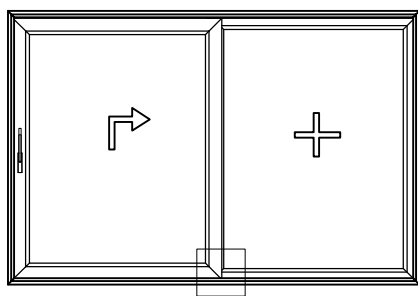

Umetanje gumenog čepa ispod krila
Insertion of rubber cap under sash

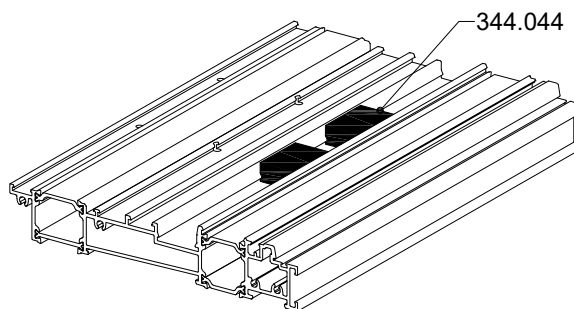
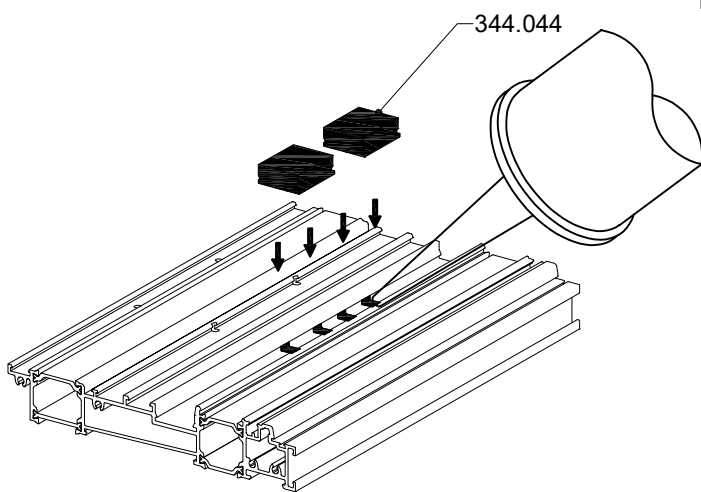
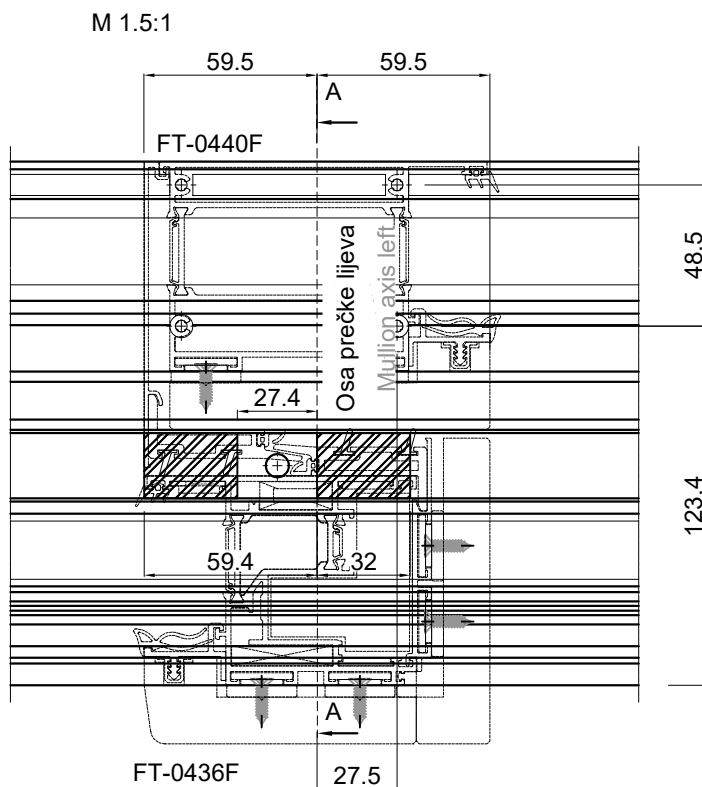
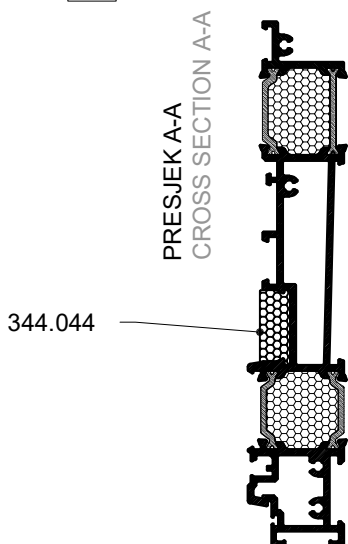

Postupak:

Procedure:

1. Površine koje se spajaju očistiti i odmastiti prikladnim sredstvom /npr. Sika Remover 208; Wurh - kat. br.: 892 130 30/.
1. Surfaces that are connecting - clean and degreased the cut with suitable products /e.g. Sika Remover 208; Wurh - kat. No.: 892 130 30/.
2. Premazati površine koje se spajaju silikonom na nekoliko mjesta te gumeni čep (344.044) umetnuti na odgovarajuće mjesto
2. Smear surfaces that are connecting with silicone on several places and the rubber cap (344.044) place on appropriate place

Napomena:

Remark:

Ljepljenjem gumenog čepa za metal osigurava se potrebna zrako - vodonepropusnost spoja.
Gluing of rubber cap on metal insures needed air and water impermeability of the joint

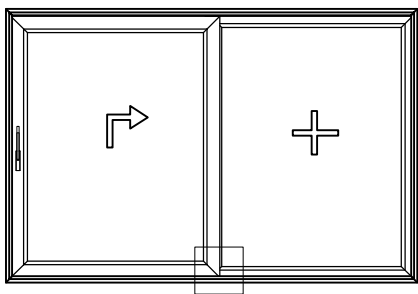

Detalj obrade PVC umetka 374.063
Detail of processing PVC insert 374.063

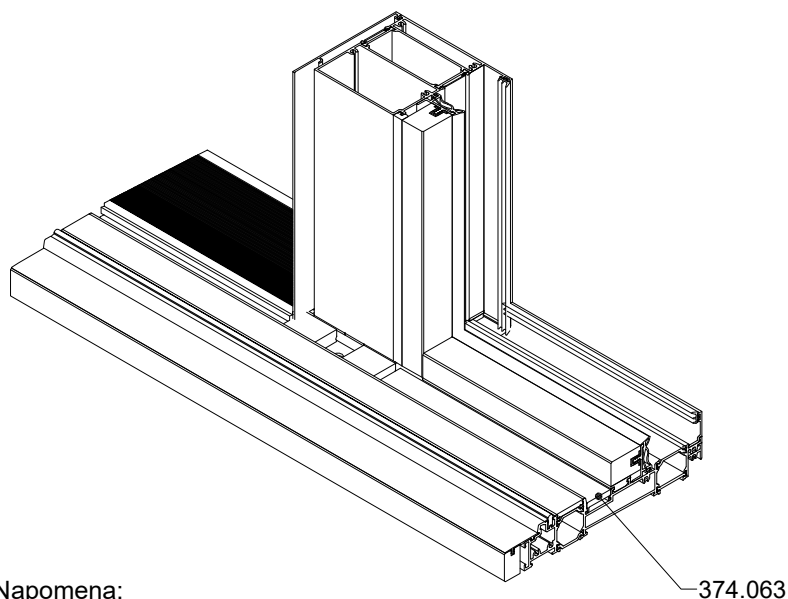
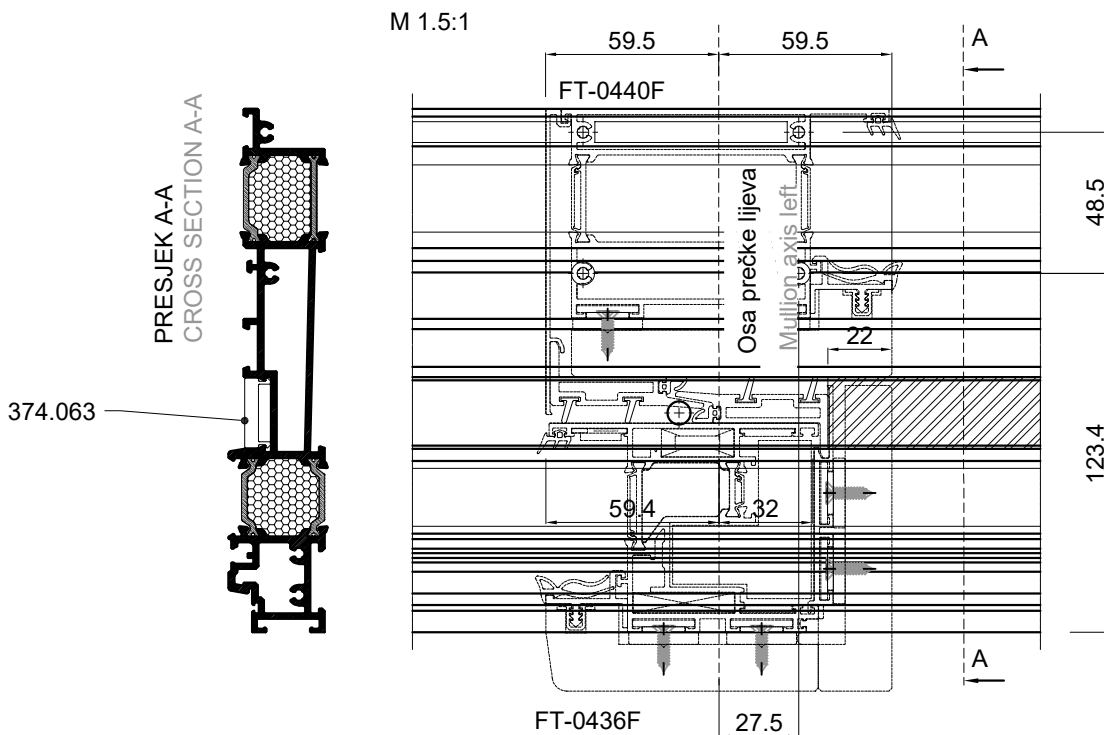

Napomena:
Remark:

Produžiti PVC umetak 374.063 za 22 mm od drvene obloge prečke rama
Prolong PVC insert 374.063 by 22 mm from wooden covering of frame mullion

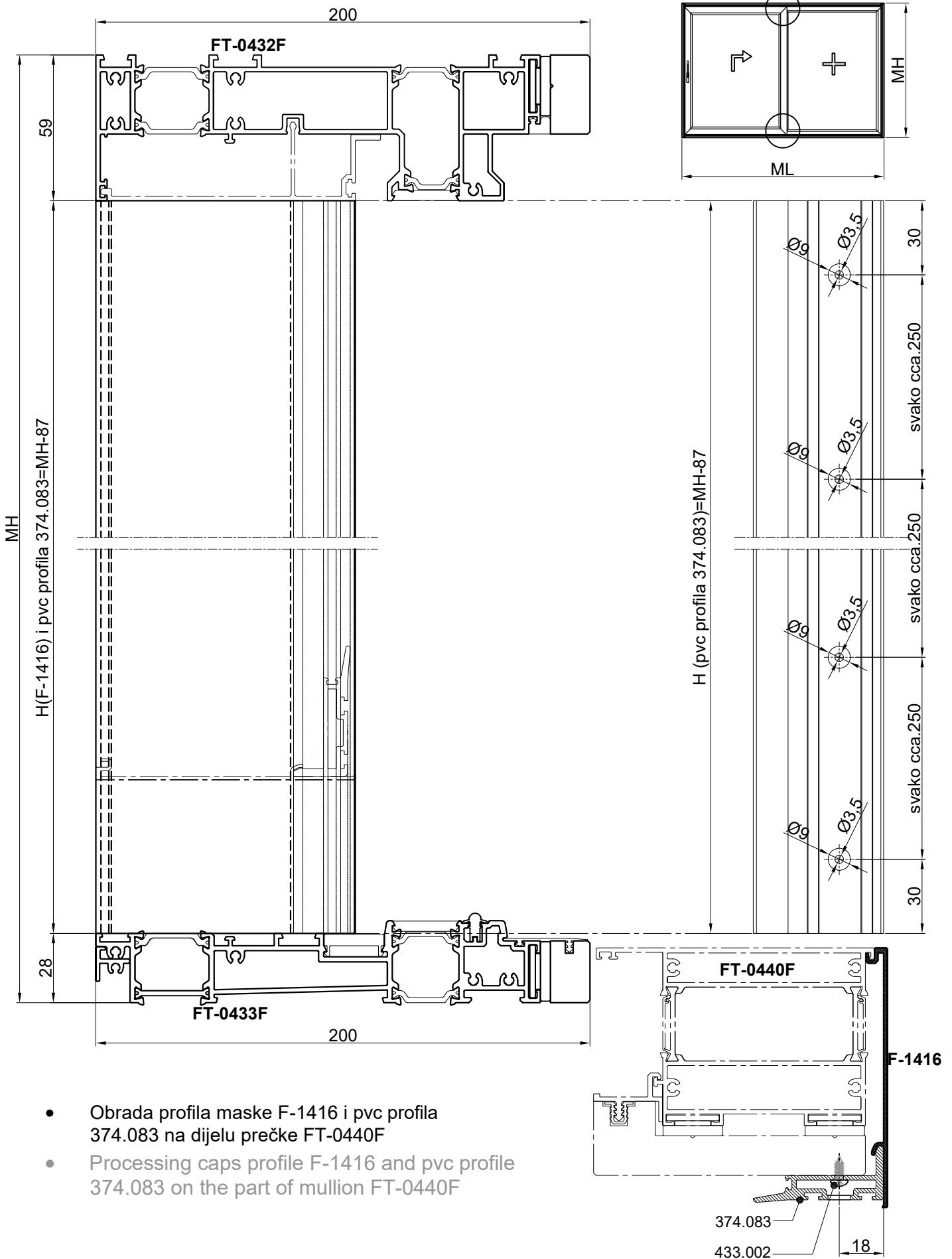

- Obrada profila maske F-1416 i pvc profila 374.083 na dijelu prečke FT-0440F
- Processing caps profile F-1416 and pvc profile 374.083 on the part of mullion FT-0440F

OBRADA ZA BRAVU Atrium Alu-HS 200 (Hautau)

- obrada na glodalici vretenastim glodalom
- za krilo FT-0436F

PROCESSING PROF ESPAG Atrium Alu-HS 300 (Hautau)

- processing od mill machine with end mill
- for sash FT-0436F

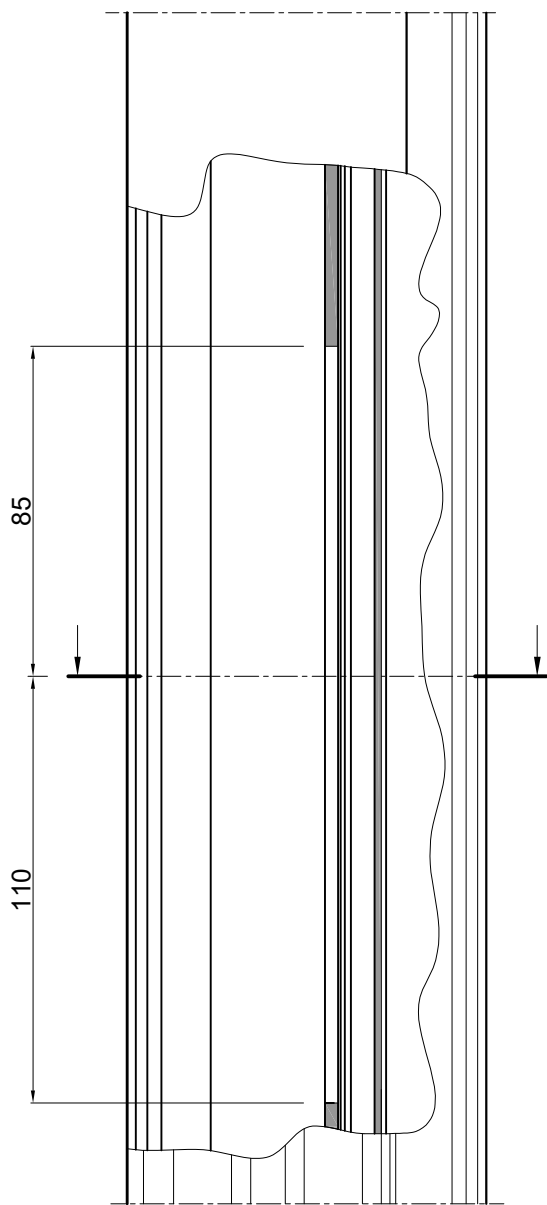

FT-0436F

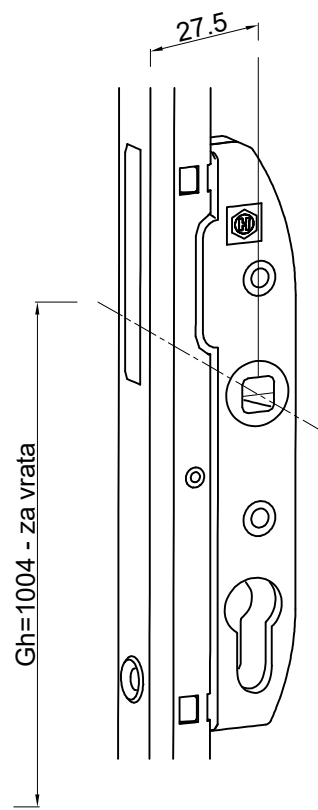
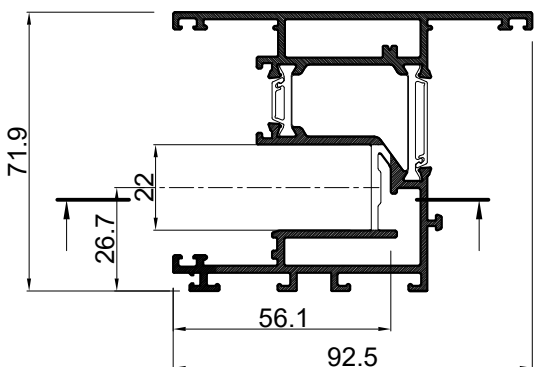
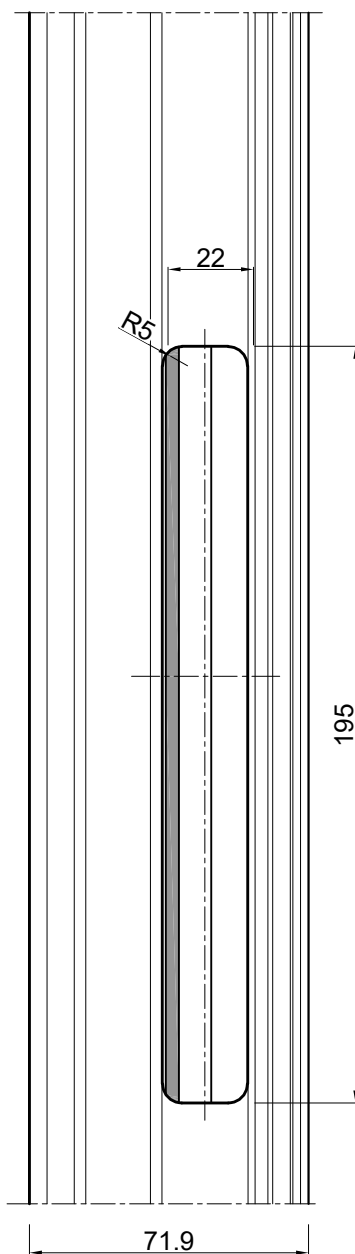

brava/espag Atrium Alu-HS 200

OBRADA PROFILA **FT-0436F** ZA RUČKU 108.001, Hautau
PROCESSING PROFILE **FT-0436F** FOR HANDLE 108.001, Hautau

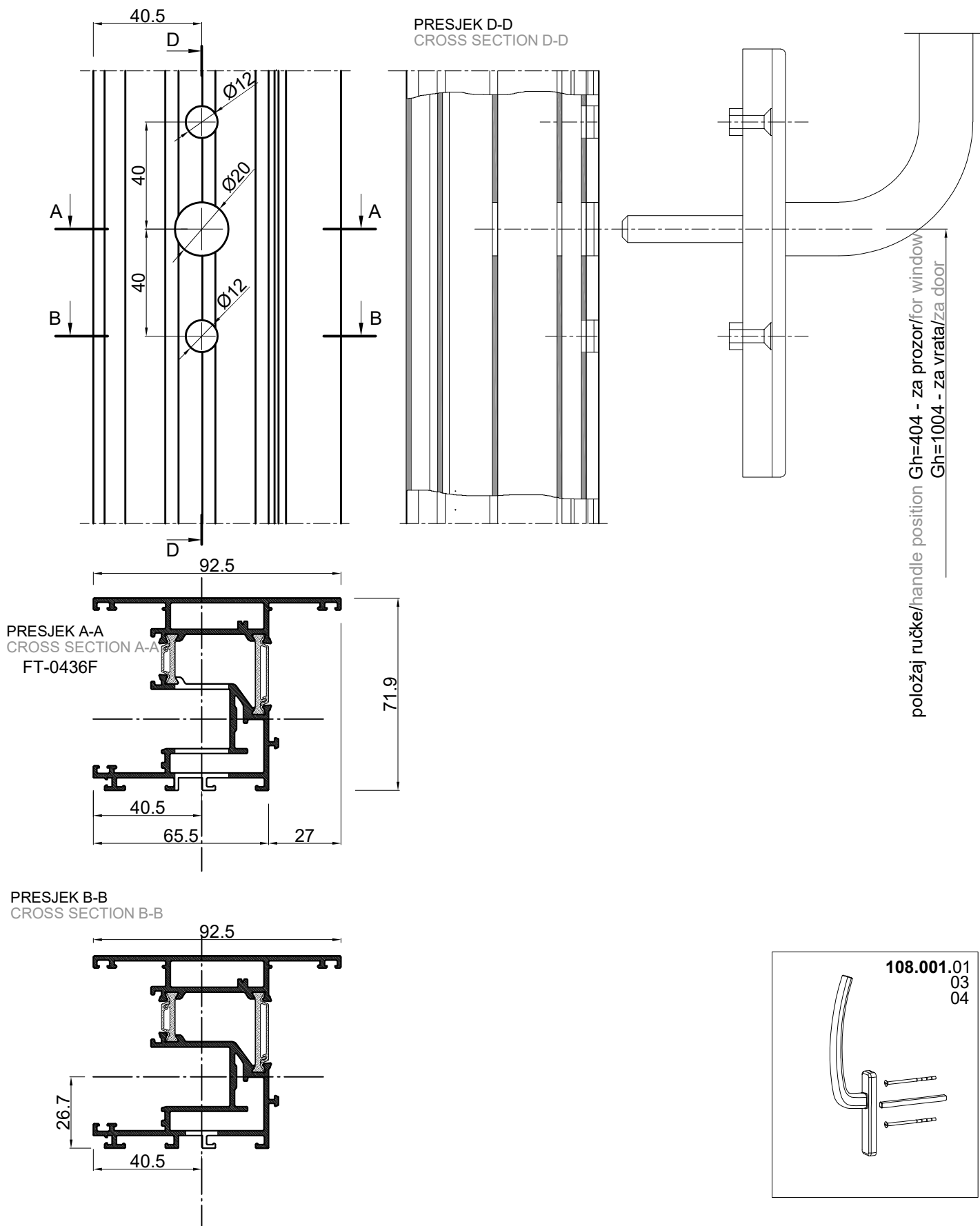

- za bravu Atrium Alu-HS 200 (Hautau)
- for espag Atrium Alu-HS 200 (Hautau)

OBRADA PROFILA FT-0436F ZA RUČKU 108.007, Hautau PROCESSING PROFILE FT-0436F FOR HANDLE 108.007, Hautau

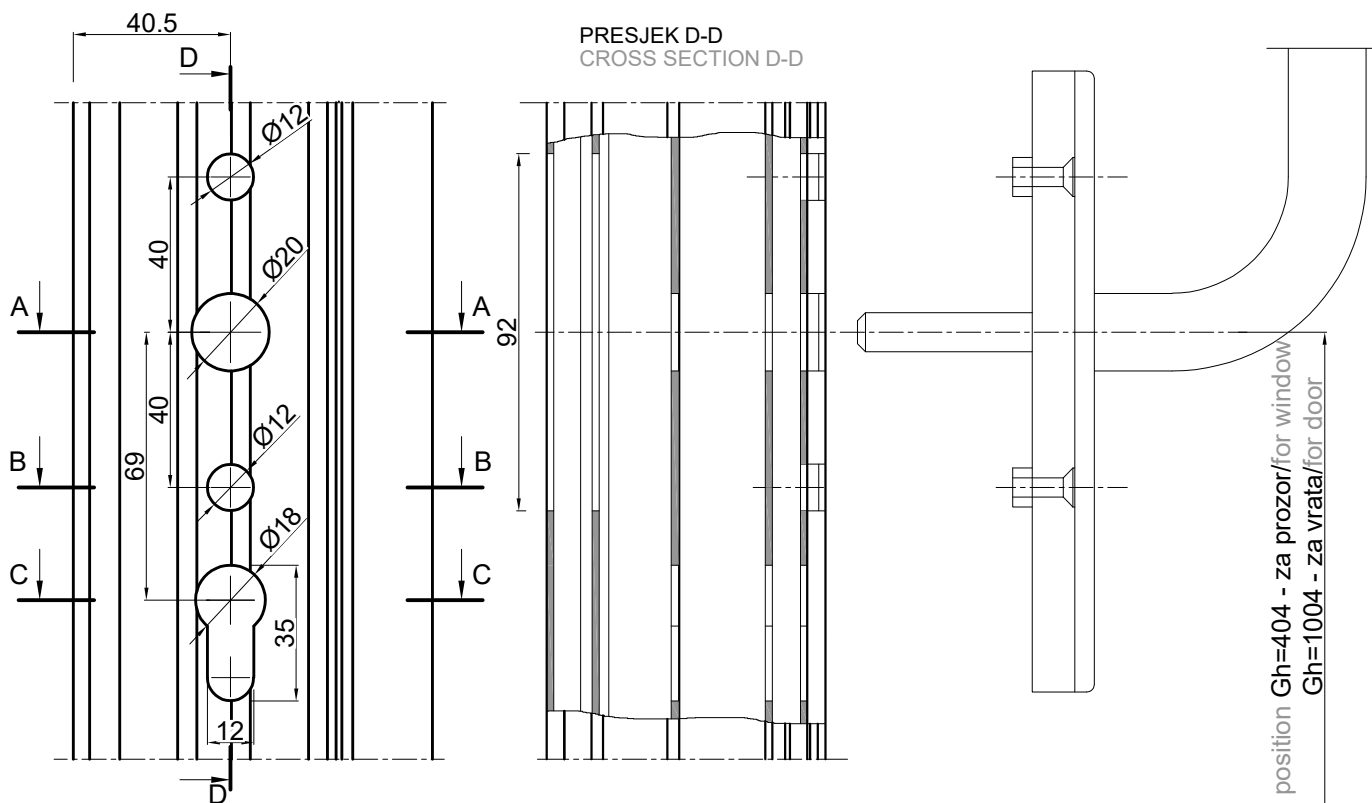

PRESJEK A-A
CROSS SECTION A-A

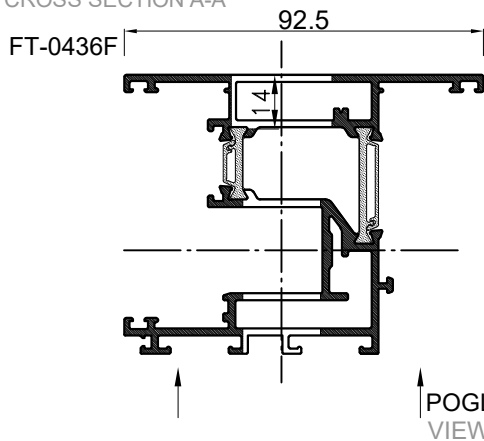

PRESJEK C-C
CROSS SECTION C-C

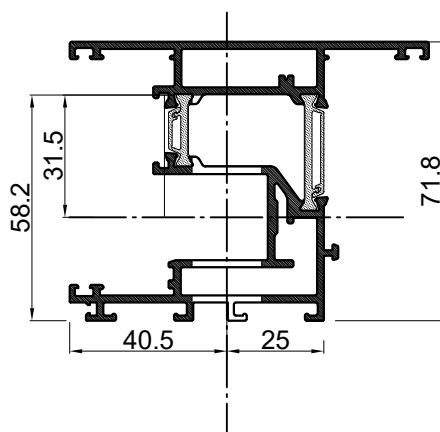

PRESJEK B-B
CROSS SECTION B-B

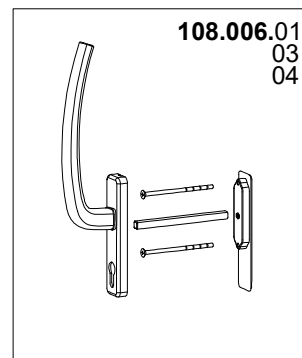
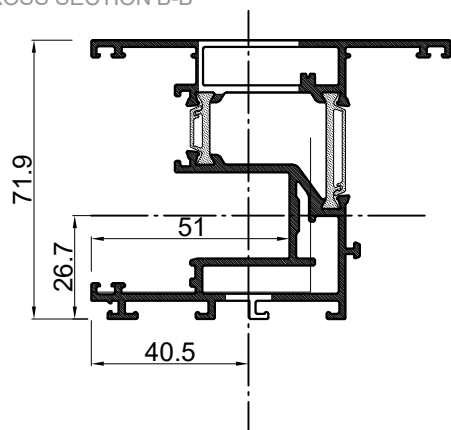

- za bravu Atrium Alu-HS 200 (Hautau)
- for espag Atrium Alu-HS 200 (Hautau)

OBRADA PROFILA FT-0436F ZA RUČKU 108.006, Hautau PROCESSING PROFILE FT-0436F FOR HANDLE 108.006, Hautau

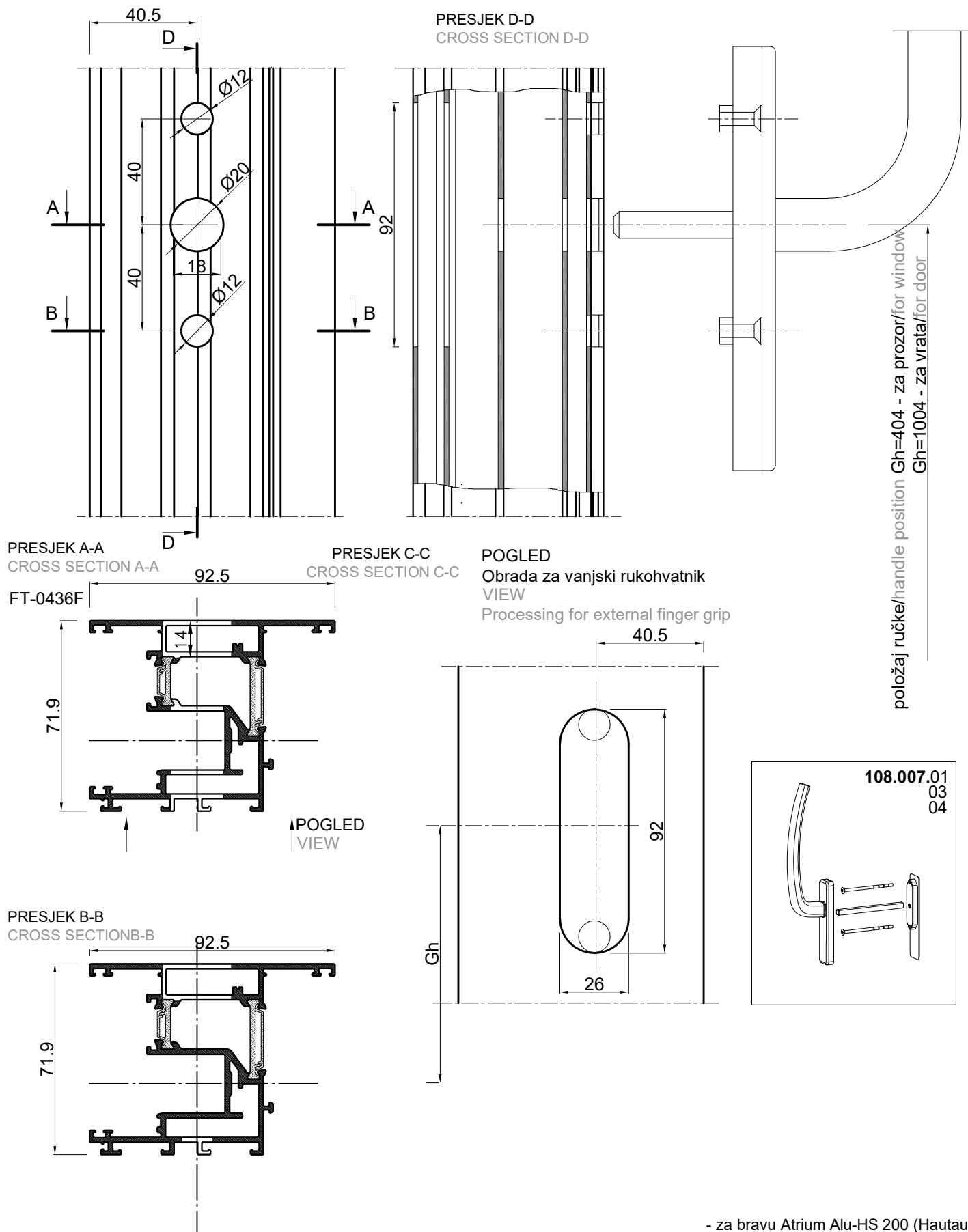

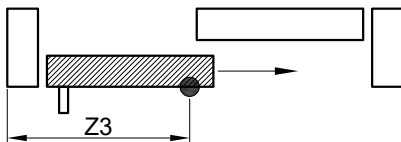
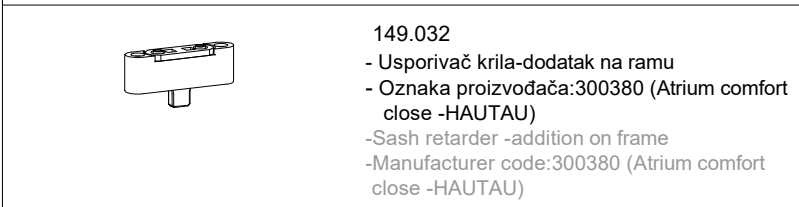
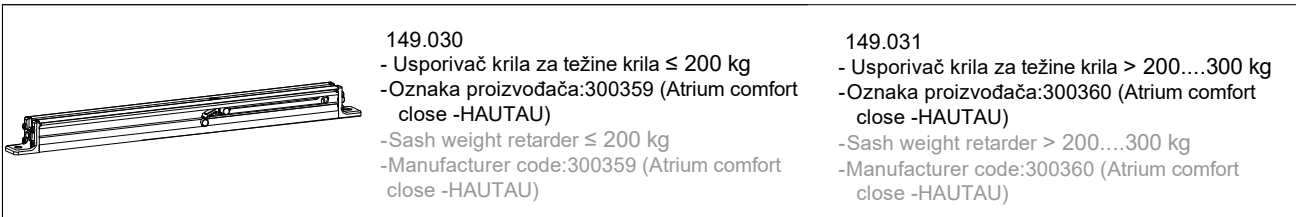
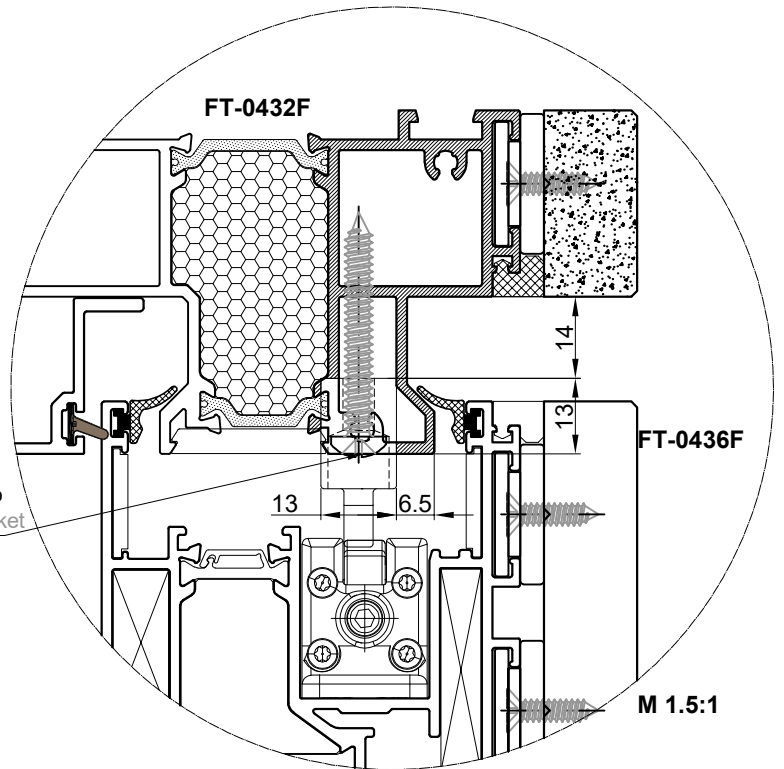
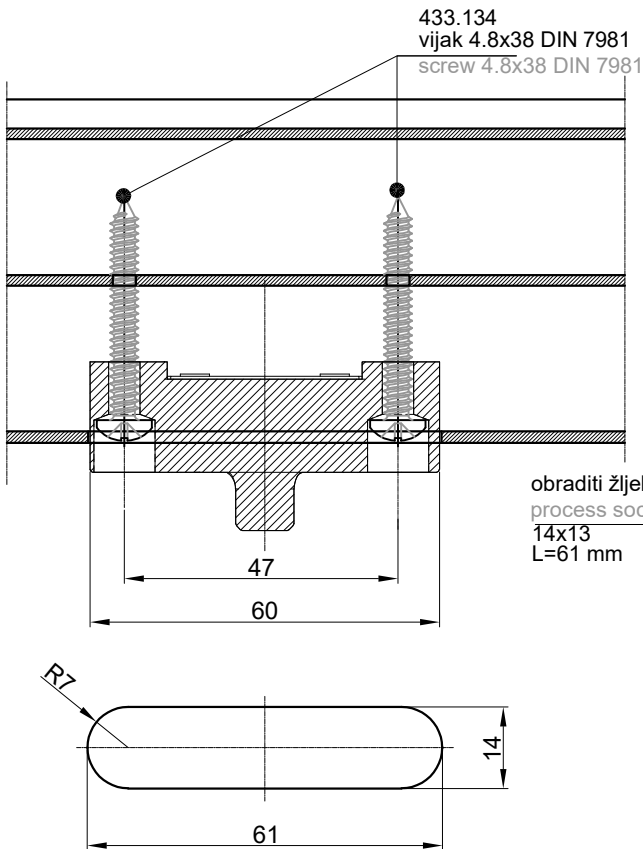

Z3= FB-70

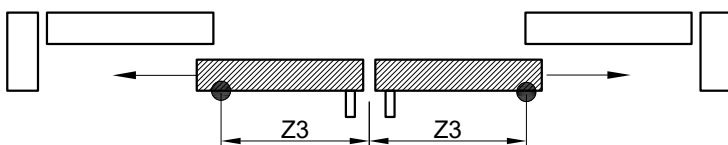
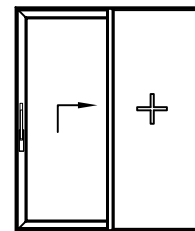

Z3= FB-123

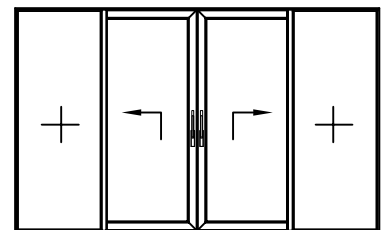

FB-širina krila
FB-sash width

- pozicija usporivača (dio na ramu)....149.032
- supprt position (part on frame)....149.032

- Mogućnost podešavanja
- Adjustment option

U slučaju netočnosti u pogledu položaja dijela koji ide na ram, krajnji položaj krila povezan s ramom može se podesiti. Postaviti ključ veličine 3 u utor 6x4 mm u utoru za podešavanje.

L (rotacija u smjeru suprotnom od kazaljke na satu): zatvaranje krila će se pomaknuti u smjeru strane ručke (0 ... 5 mm).

R (rotacija u smjeru kazaljke na satu): zatvaranje krila će se pomaknuti u smjeru strana bez ručke (0 ... 5 mm)

In case of inaccuracy concerning position of the frame piece, the end position of the sash related to the frame can be adjusted. Put allen key size 3 through the groove 6 x 4 mm into the adjusting screw.

L (counter-clockwise rotation): closing of sash will be shifted in direction of handle side (0 ... 5 mm).

R (clockwise rotation): closing of sash will be shifted in direction of non-handle side (0 ... 5 mm)

- NAPOMENA:

Podešavati se može nakon ostakljivanja krila i montaže na ram.

- NOTE:

Adjustments may be changed after glazing the sash and mounting the frame!

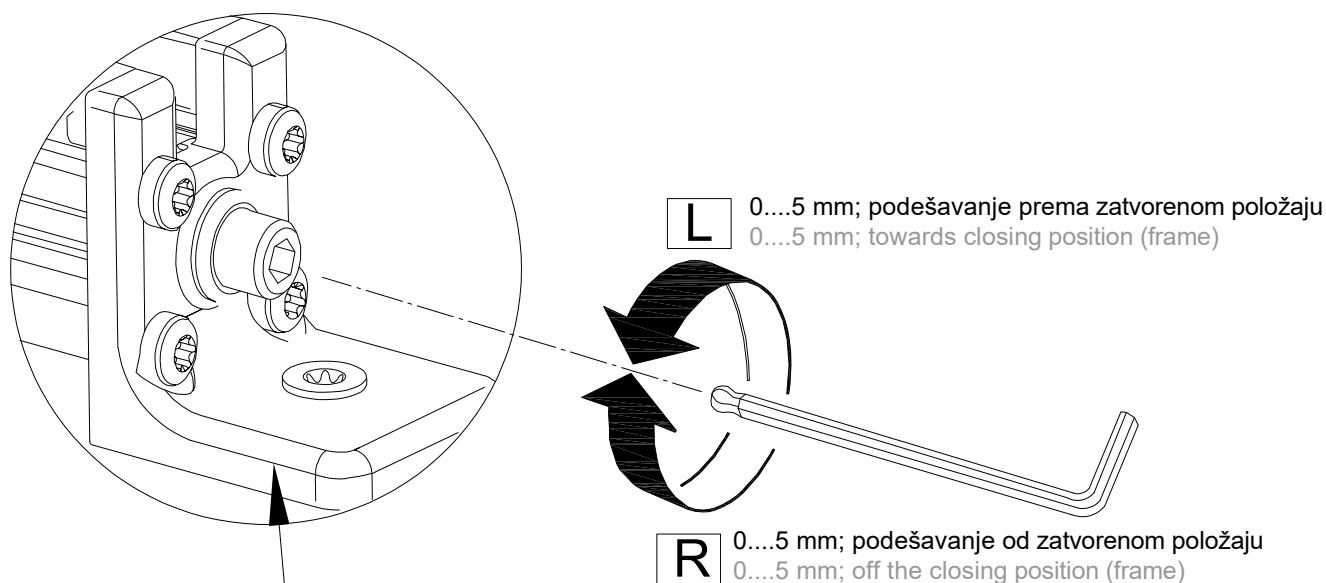

podešavanje položaja zatvaranje
adjustment at closing edge

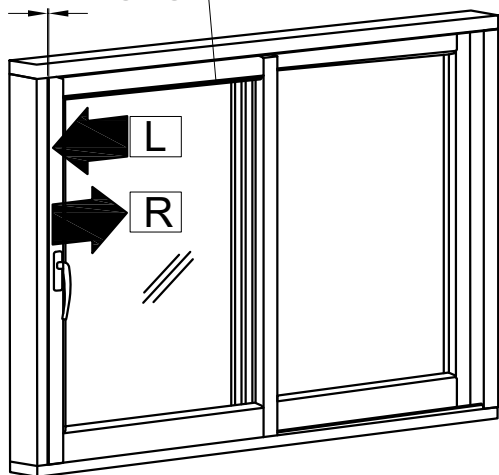

Montaža usporivača na ramu i kilu

Određivanje pozicije dijela na ramu i usporivača na krlu.

Usporivač se montira u nenapregnutom položaju. Pozicija dijela na ramu određuje si iz formule $Z3=FB(\text{širina krla})-70$. $Z3$ -mjera od početka rama. Determining the position of the part on the frame and the comfort close on the sash.

Comfort close is mounted in untensioned position. Position part of the frame determining: $Z3=FB(\text{sash width})-70$ $Z3$ -measurement from beginig sash

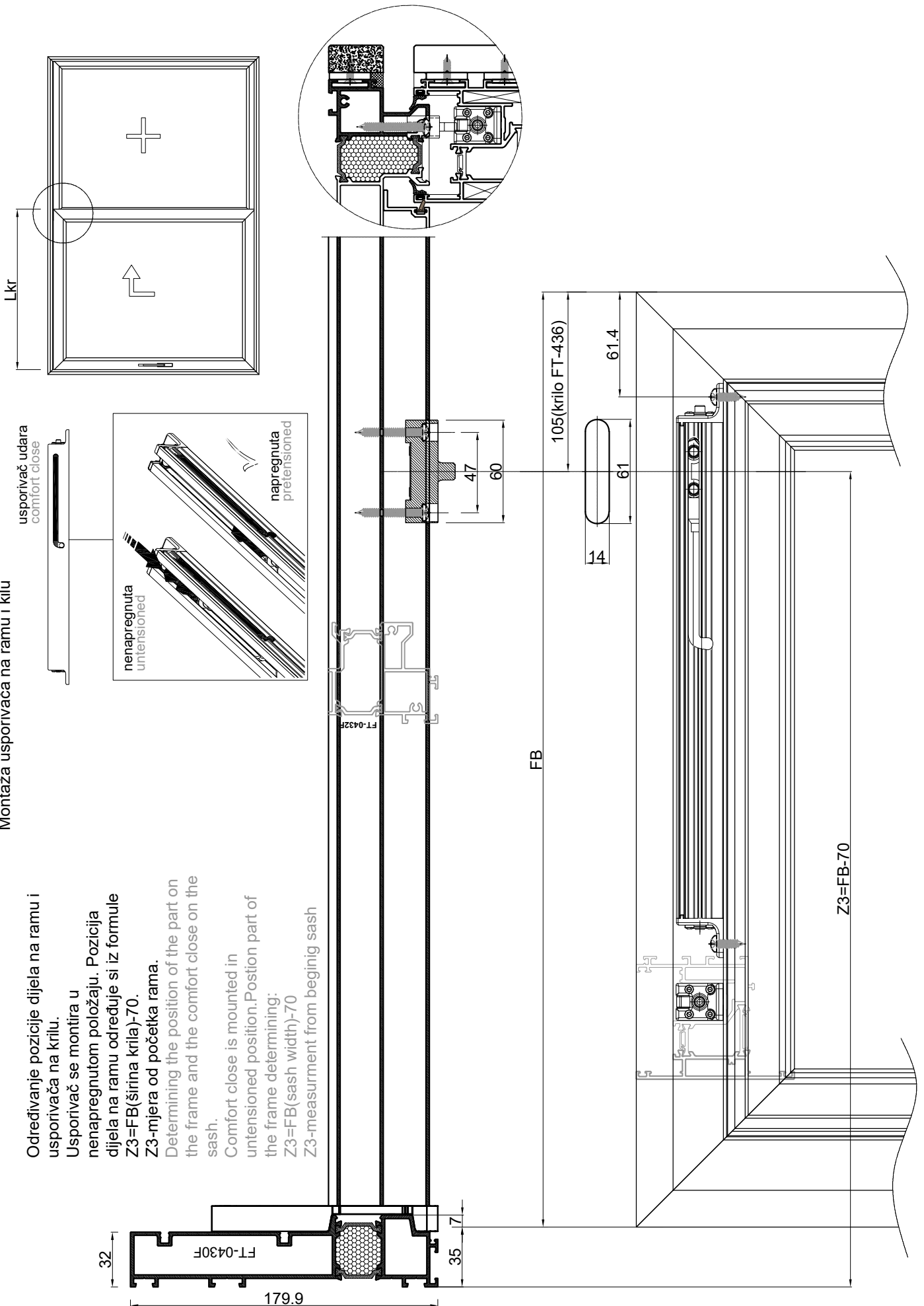

MONTAŽA OPRUGE ZA LAGANO POKRETANJE RUČKE PODIZNO KLIZNOG MEHANIZMA MOUNT SPRING ASSIST SYSTEM WITHIN THE ESPAG

Opruga za težine krila
Accessories for sash weight
≤ 200 kg

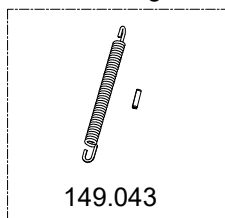

Opruga za težine krila
Accessories for sash weight
> 200 kg

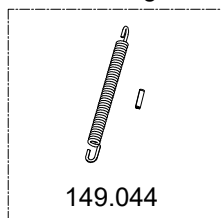

- A..... Postaviti bravu u dignuti položaj (otključano) (A.1/A.2).
 - B..... Postaviti zatik u određeni položaj na bravi (već postoji rupa na bravi)
 - C..... Pozicija opruge na bravi
 - D..... Povuci kraj zatezne opruge preko zuba na bravi (pomoću odvijača) (D.1/D.2).
 - E..... Ispravno namontirana opruga
- A.....Bring espag into raised position (A.1/A.2).
 - B.....Drive in the dowel pin.
 - C.....Position tension spring within the espag.
 - D.....Pull the end of the tension spring over the tappet at the drive rod (by means of a screw driver) (D.1/D.2).
 - E..... Correct mounted spring assist system

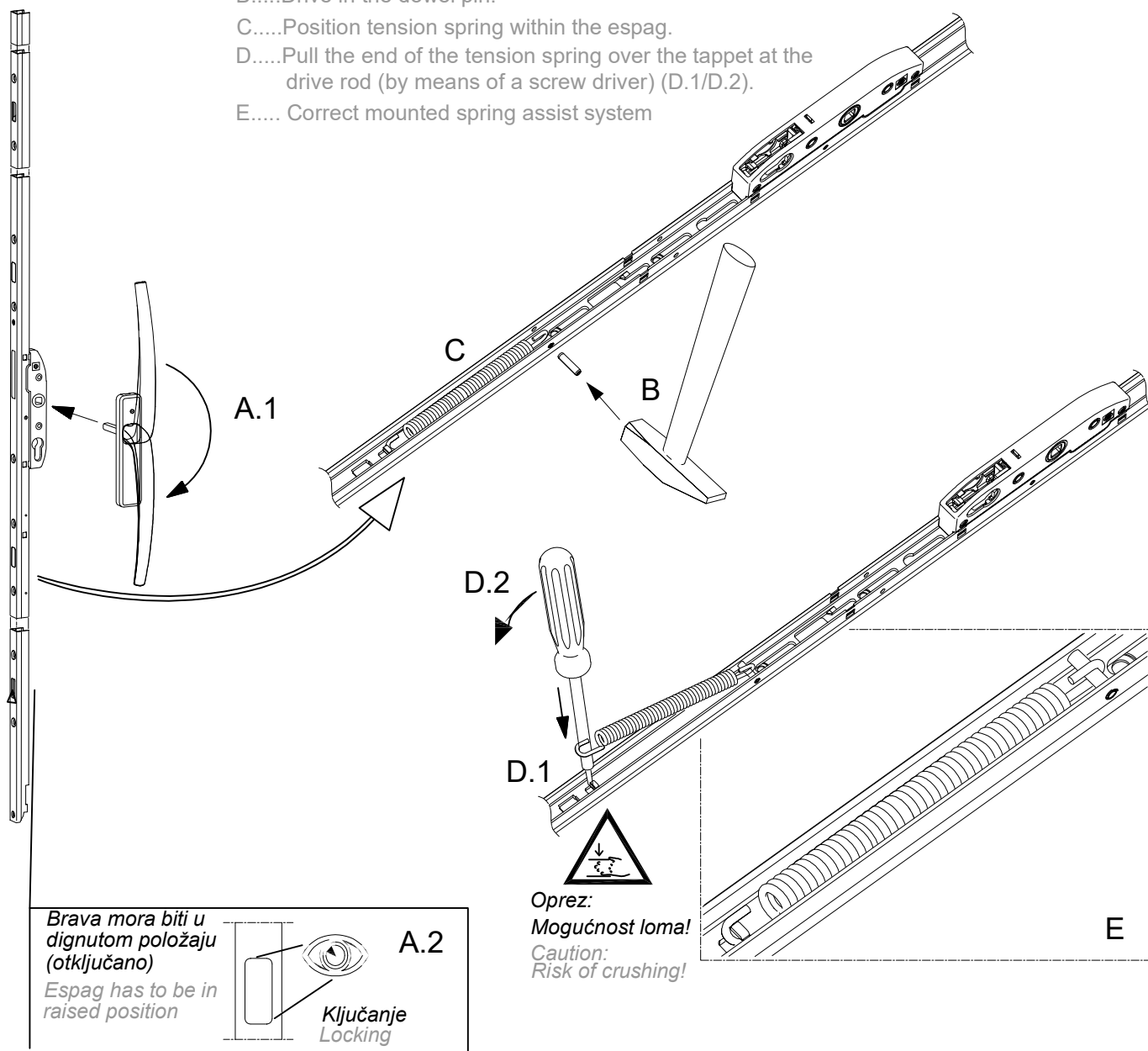

Rezne liste Cutting lists

Profili Profiles	Kom Pcs	Mjera Measure	Pilanje Cutting
FT-0430F Okomica rama - strana krila	1	MH	90-90
FT-0431F Okomica rama - fiksna strana	1	MH	90-90
FT-0433F Vodoravnica rama - prag	1	Lpr=ML-60	90-90
FT-0432F Vodoravnica rama - gornji dio	1	Lgr=ML-60	90-90
FT-0436F Okomica krila	2	Hkr=MH-78	45-45
FT-0436F Vodoravnica krila	2	Lkr=ML/2-16	45-45
FT-0442F Prečka (bez drvene obloge)	1	Hpr=MH-60	90-90
F-1350 Vodoravna lajsna-krilo	2	Llk=Lkr-187	90-90
F-1350 Okomita lajsna-krilo	2	Hlk=Hkr-187	90-90
F-1350 Vodoravna lajsna-fiksno	2	Llf=ML-Lkr-116	90-90
F-1350 Okomita lajsna-fiksno	2	Hlf=MH-63.5	90-90
F-1414 Lajsna na ramu FT-0430F	1	Hi=MH-87	90-90
F-1415 Lajsna na krilu - uz prečku	1	Hi=MH-78	90-90
F-1416 Lajsna na prečki	1	Hi=MH-87	90-90
F-1417 Lajsna na pragu	1	Li=ML/2-116.5	90-90
F-1418 Okapnica na pragu	1	Lo=ML-60	90-90
F-1419 Staklo lajsna - fiksni dio	1	Lfix=ML/2-98.5	90-90
F-1420 Držač drvene obloge 600.011	1	MH	90-90
F-1421 Lajsna na ramu FT-0432F	1	Li=ML/2-116.5	90-90
F-1428 Umetak ispod brave	1	Hu=MH-180	90-90
F-1112 Al. vodilica	1	Lš=ML-103	90-90
Drvene obloge Wooden coverings			
600.011 Okomica uz ram FT-0430F	1	MH	90-90
600.011 Vodoravnica uz ram FT-0432F	1	Li=ML-32	90-90
600.012 Obloga krila uz prečku	1	Ho=MH-78	90-90
600.016 Obloga prečke na FT-0442F	1	Ho=MH-62	90-90
600.015 Obloga rama FT-0433F	1	Lo=ML-32	90-90
600.016 Vodoravna obloga na fix. dijelu	2	Lo=ML/2-100.5	90-90
600.017 Vodoravnica krila	2	Lo=ML/2-16	45-45
600.017 Okomica krila	2	Ho=MH-78	45-45
600.018 Okomica uz ram FT-0431F	1	Ho=MH-57	90-90
Okovi Hardware			
710.193 Kutnik krila	4		
710.401 Pomoćni kutnik krila	4		
730.017 Pomoćni kutnik krila	8		
730.002 Pomoćni kutnik krila	8		
731.010 Pomoćni kutnik krila	4		
Podizno-klizni mehanizam HAUTAU			
Brtve i dodatci Gaskets and accessories			
321.002 Brtva u krilu		(ML+2MH)x2	
327.003 Brtva u krilu		2Lkr+2Hkr	
344.073 Brtva na prečki		2MH	
344.045 Brtva u krilu		(ML+2MH)x2	
344.049 Brtva u krilu		(ML+2MH)x2	
348.061 Brtva na ramu		2ML+MH	
344.062 Brtva na ramu		ML/2	
344.063 Brtva na ramu i krilu		2ML+4MH	
344.064 Brtva ispod lajsne na pragu		ML/2	
344.065 Brtva na pragu		ML	
348.067 Brtva u krilu		ML	
340.013 Ispuna ispod stakla		(ML+2MH)x2	
345.010 Ublaživač udara	2		
347.011 QL brtva 7mm		2ML+MH	
347.012 QL brtva 10mm		4MH	
360.009 Monodrain - izvod kapljevina		Lkr/400	
365.058 Set umetaka za lijeva vrata ili	1		
365.059 Set umetaka za desna vrata	1		
371.021 Set umetaka za masku krila	1		
374.083 PVC umetak-spoj prečke i kr.	1	Hkr	90-90
374.083 PVC umetak-spoj prečke i kr.	1	MH-87	90-90
374.063 PVC umetak na pragu	1	(ML/2)-79.5	
375.048 Umetak - kopča		(ML/600)+(4MH/300)	
375.050 Kopča za drvo		(2ML/250)+(MH/250) + (ML/200)+(3MH/200)	
373.078 Usmjerivač krila	4		
344.044 Gumeni umetak ispod krila	2		
347.009 Četkica u gornjem dijelu	1		
Staklo Glass			
46 mm Staklo na fiksnoj dijelu		(ML/2 - 68.5) x (MH-79)	
46 mm Staklo na krilu		(Lkr-155) x (Hkr-155)	

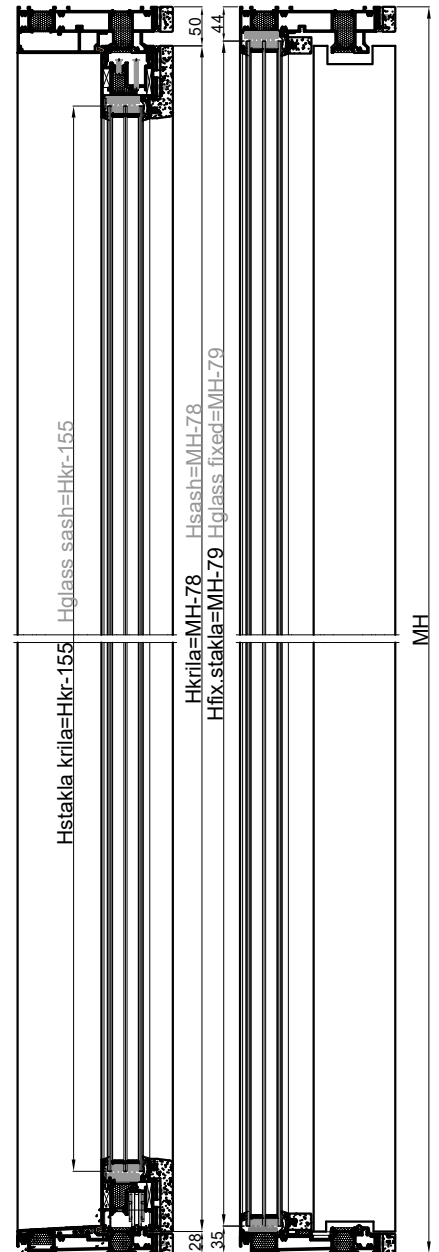
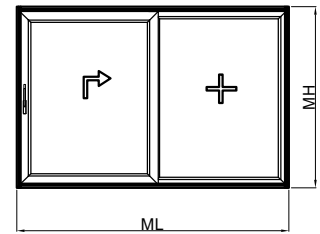

Lprečke=ML/2+68.5 Lmullion=ML/2+68.5
Lstakla fixnog=ML/2-68.5 Lgl.fixed=ML/2-68.5

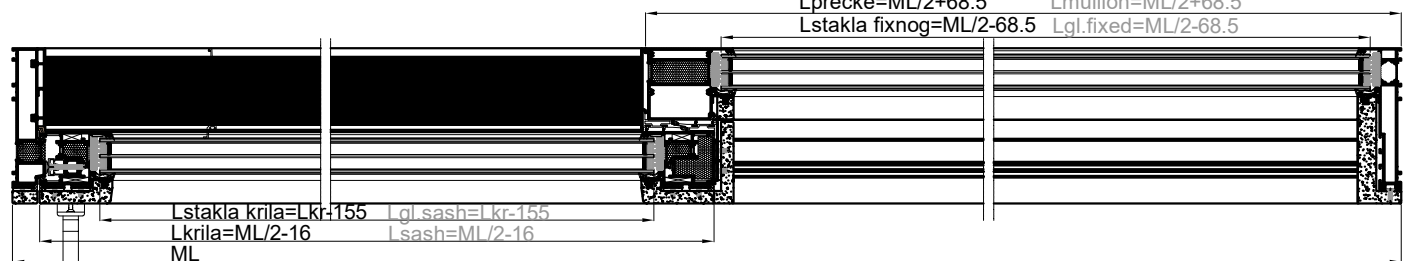

Profili Profiles		Kom Pcs	Mjera Measure	Pilanje Cutting
FT-0430F	Okomica rama - strana krila	1	MH	90-90
FT-0431F	Okomica rama - fiksna strana	1	MH	90-90
FT-0433F	Vodoravnica rama - prag	1	Lpr=ML-60	90-90
FT-0432F	Vodoravnica rama - gornji dio	1	Lgr=ML-60	90-90
FT-0436F	Okomica krila	2	Hkr=MH-78	45-45
FT-0436F	Vodoravnica krila	2	Lkr=ML/2-16	45-45
FT-0440F	Prečka (s drvenom oblogom)	1	Hpr=MH-60	90-90
F-1350	Vodoravna lajsna-krilo	2	Llk=Lkr-187	90-90
F-1350	Okomita lajsna-krilo	2	Hlk=Hkr-187	90-90
F-1350	Vodoravna lajsna-fiksno	2	Llf=ML-Lkr-116	90-90
F-1350	Okomita lajsna-fiksno	2	Hlf=MH-63.5	90-90
F-1414	Lajsna na ramu FT-0430F	1	HI=MH-87	90-90
F-1415	Lajsna na krilu - uz prečku	1	HI=MH-78	90-90
F-1416	Lajsna na prečki	1	HI=MH-87	90-90
F-1417	Lajsna na pragu	1	LI=ML/2-116.5	90-90
F-1418	Okapnica na pragu	1	Lo=ML-60	90-90
F-1419	Staklo lajsna - fiksni dio	1	Lfix=ML/2-98.5	90-90
F-1420	Držač drvene obloge 600.011	1	MH	90-90
F-1421	Lajsna na ramu FT-0432F	1	LI=ML/2-116.5	90-90
F-1428	Umetak ispod brave	1	Hu=MH-180	90-90
F-1112	Al. vodilica	1	Lš=ML-103	90-90
Drvene obloge Wooden coverings				
600.011	Okomica uz ram FT-0430F	1	MH	90-90
600.011	Vodoravnica uz ram FT-0432F	1	LI=ML-32	90-90
600.012	Obloga krila uz prečku	1	Ho=MH-78	90-90
600.013	Obloga prečke na FT-0440F	1	Ho=MH-62	90-90
600.015	Obloga rama FT-0433F	1	Lo=ML-32	90-90
600.016	Vodoravna obloga na fix. dijelu	2	Lo=ML/2-100.5	90-90
600.017	Vodoravnica krila	2	Lo=ML/2-16	45-45
600.017	Okomica krila	2	Ho=MH-78	45-45
600.018	Okomica uz ram FT-0431F	1	Ho=MH-57	90-90
Okovi Hardware				
710.193	Kutnik krila	4		
710.401	Pomoćni kutnik krila	4		
730.017	Pomoćni kutnik krila	8		
730.002	Pomoćni kutnik krila	8		
731.010	Pomoćni kutnik krila	4		
Podizno-klizni mehanizam HAUTAU				
Brtve i dodatci Gaskets and accessories				
321.002	Brtva u krilu		(ML+2MH)x2	
327.003	Brtva u krilu		2Lkr+2Hkr	
344.073	Brtva na prečki		2MH	
344.045	Brtva u krilu		(ML+2MH)x2	
344.049	Brtva prema staklu		(ML+2MH)x2	
348.061	Brtva na ramu		2ML+MH	
344.062	Brtva na ramu		ML/2	
344.063	Brtva na ramu i krilu		ML+MH+2Lkr+2Hkr	
344.064	Brtva ispod lajsne na pragu		ML/2	
344.065	Brtva na pragu		ML	
348.067	Brtva u krilu		2Lkr	
340.013	Ispuna ispod stakla		(ML+2MH)x2	
345.010	Ublaživač udara	2		
347.011	QL brtva 7mm		2ML+MH	
347.012	QL brtva 10mm		4MH	
360.009	Monodrain - izvod kapljevina		Lkr/400	
365.058	Set umetaka za lijeva vrata ili	1		
365.059	Set umetaka za desna vrata	1		
371.021	Set umetaka za masku krila	1		
374.083	PVC umetak - spoj preč. i krila	1	Hkr	90-90
374.083	PVC umetak - spoj preč. i krila	1	MH-87	90-90
374.063	PVC umetak na pragu	1	(ML/2)-79.5	
375.048	Umetak - kopča		(ML/600)+(4MH/300)	
375.050	Kopča za drvo		(2ML/250)+(MH/250)+(ML/200)+(3MH/200)	
373.078	Usmjerivač krila	4		
344.044	Gumeni umetak ispod krila	2		
347.009	Četkica u gornjem dijelu	1		
Staklo Glass				
46 mm	Staklo na fiksnoj dijelu		(ML/2 - 68.5) x (MH-79)	
46 mm	Staklo na krilu		(Lkr-155) x (Hkr-155)	

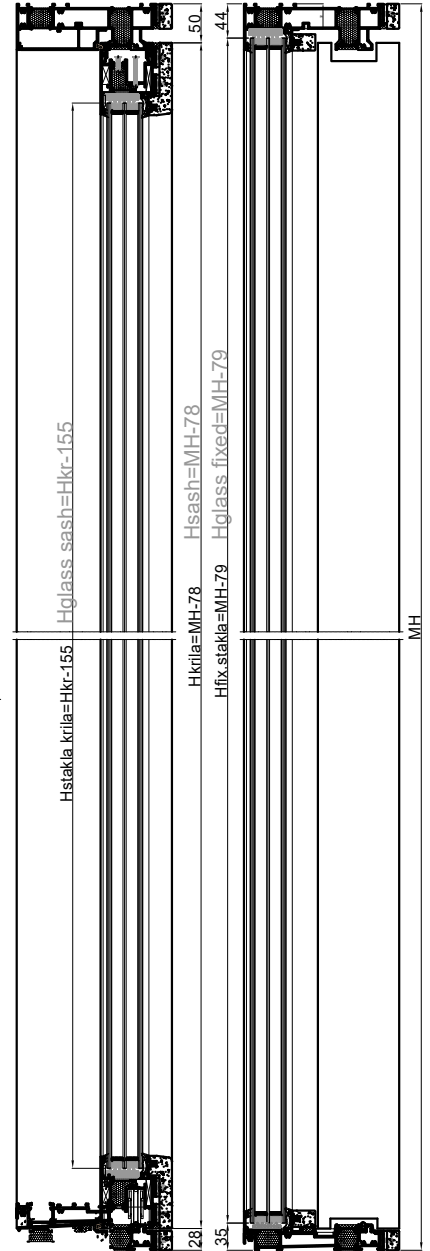
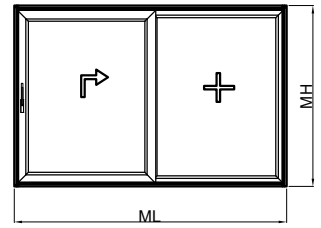

Lprečke=ML/2+68.5 Lmullion=ML/2+68.5
Lstakla fixnog=ML/2-68.5 Lgl.fixed=ML/2-68.5

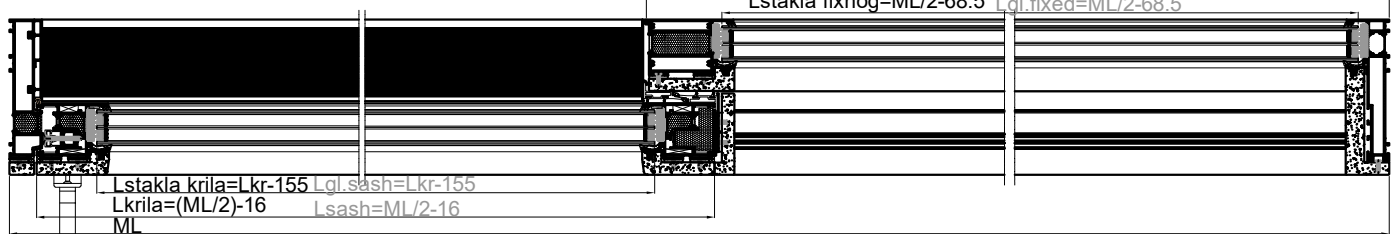

Profili Profiles	Kom Pcs	Mjera Measure	Pilanje Cutting
FT-0430F Okomica rama - strana krila	Vertical frame profile - sash side	1	MH 90-90
FT-0431F Okomica rama - fiksna strana	Vertical frame profile - fixed side	1	MH 90-90
FT-0433F Vodoravnica rama - prag	Horizontal frame profile - treshold	1	Lpr=ML-60 90-90
FT-0432F Vodoravnica rama - gornji dio	Horizontal frame profile - topside	1	Lgr=ML-60 90-90
FT-0436F Okomica krila	Vertical sash profile	2	Hkr=MH-78 45-45
FT-0436F Vodoravnica krila	Horizontal sash profile	2	Lkr=ML/2-16 45-45
FT-0442F Prečka (bez drvene obloge)	Mullion (without wooden covering)	1	Hpr=MH-60 90-90
FT-0446F Profil umetka za fiksni dio	Insert profile -fixed	2	Lum=ML/2-45 90-90
F-1350 Vodoravna lajsna-krilo	Horizontal plate - sash	2	Llk=Lkr-187 90-90
F-1350 Okomita lajsna-krilo	Vertical plate - sash	2	Hlk=Hkr-187 90-90
F-1350 Vodoravna lajsna-fiksno	Horizontal plate - fixed	2	Llf=ML-Lkr-116 90-90
F-1350 Okomita lajsna-fiksno	Vertical plate - fixed	2	Hlf=MH-217.5 90-90
F-1414 Lajsna na ramu FT-0430F	Plate on frame FT-0430F	1	Hi=MH-87 90-90
F-1415 Lajsna na krilu - uz prečku	Plate on sash - to the mullion	1	Hi=MH-78 90-90
F-1416 Lajsna na prečki	Plate on mullion	1	Hi=MH-87 90-90
F-1417 Lajsna na pragu	Plate on treshold	1	Li=ML/2-116.5 90-90
F-1418 Okapnica na pragu	Drip profile on treshold	1	Lo=ML-60 90-90
F-1419 Staklo lajsna - fiksni dio	Glazing bead - fixed part	1	Lfix=ML/2-98.5 90-90
F-1420 Držač drvene obloge 600.011	Wooden covering holder 600.011	1	MH 90-90
F-1421 Lajsna na ramu FT-0432F	Plate on frame FT-0432F	1	Li=ML/2-116.5 90-90
F-1428 Umetak ispod brave	Insert under the lock	1	Hu=MH-180 90-90
F-1112 Al. vodilica	Al. guide	1	Lš=ML-103 90-90
F-1649 Držač drvene obloge 600.030	Wooden covering holder 600.030	4	Lo=ML/2-100.5 90-90
Drvene obloge Wooden coverings			
600.011 Okomica uz ram FT-0430F	Vertical cover to the frame FT-0430F	1	MH 90-90
600.011 Vodoravnica uz ram FT-0432F	Horizontal cover to the frame FT-0432F	1	Li=ML-32 90-90
600.012 Obloga krila uz prečku	Sash coverings to the mullion	1	Ho=MH-78 90-90
600.016 Obloga prečke na FT-0442F	Mullion coverings on FT-0442F	1	Ho=MH-62 90-90
600.015 Obloga rama FT-0433F	Frame coverings FT-0433F	1	Lo=ML-32 90-90
600.030 Vodoravna obloga na fix. dijelu	Horizontal coverings on fix. section	2	Lo=ML/2-100.5 90-90
600.017 Vodoravnica krila	Horizontal sash profile	2	Lo=ML/2-16 45-45
600.017 Okomica krila	Vertical frame profile	2	Ho=MH-78 45-45
600.018 Okomica uz ram FT-0431F	Vertical cover to the sash FT-0431F	1	Ho=MH-57 90-90
Okovi Hardware			
710.193 Kutnik krila	Sash corner bracket	4	
710.401 Pomoćni kutnik krila	Support frame corner bracket	4	
730.017 Pomoćni kutnik krila	Support frame corner bracket	8	
730.002 Pomoćni kutnik krila	Support frame corner bracket	8	
731.010 Pomoćni kutnik krila	Support frame corner bracket	4	
Podizno-klizni mehanizam HAUTAU			
Brtve i dodatci Gaskets and accessories			
321.002 Brtva u krilu	Gasket in sash		(ML+2MH)x2
327.003 Brtva u krilu	Gasket in sash		2Lkr+2Hkr
344.073 Brtva na prečki	Gasket on mullion		2MH
344.045 Brtva u krilu	Gasket in sash		(ML+2MH)x2
344.049 Brtva u krilu	Gasket in sash		(ML+2MH)x2
348.061 Brtva na ramu	Gasket on frame		2ML+MH
344.062 Brtva na ramu	Gasket on frame		ML/2
344.063 Brtva na ramu i krilu	Gasket on frame and sash		2ML+4MH
344.064 Brtva ispod lajsne na pragu	Gasket under the plate on treshold		ML/2
344.065 Brtva na pragu	Gasket on treshold		ML
348.067 Brtva u krilu	Gasket in sash		ML
340.013 Ispuna ispod stakla	Filling under the glass		(ML+2MH)x2
345.010 Ublaživač udara	Bump absorber	2	
347.011 QL brtva 7mm	QL gasket 7mm		2ML+MH
347.012 QL brtva 10mm	QL gasket 10mm		4MH
360.009 Monodrain - izvod kapljevina	Monodrain - liquid excerpt		Lkr/400
365.058 Set umetaka za lijeva vrata ili	Set of inserts for left door or	1	
365.059 Set umetaka za desna vrata	Set of inserts for right door	1	
371.021 Set umetaka za masku krila	Set of inserts for mullion mask	1	
374.083 PVC umetak-spoj prečke i kr.	PVC insert-contact of mullion and sash	1	Hkr 90-90
374.083 PVC umetak-spoj prečke i kr.	PVC insert-contact of mullion and sash	1	MH-87 90-90
374.063 PVC umetak na pragu	PVC insert on treshold	1	(ML/2)-79.5
375.048 Umetak - kopča	Insert - Clamp		(ML/600)+(4MH/300)
375.050 Kopča za drvo	Clamp for wood		(2ML/250)+(MH/250) + (ML/200)+(3MH/200)
373.078 Usmjerivač krila	Sash router	4	
344.044 Gumeni umetak ispod krila	Rubber insert	2	
347.009 Četkica u gornjem dijelu	Brush insert	1	

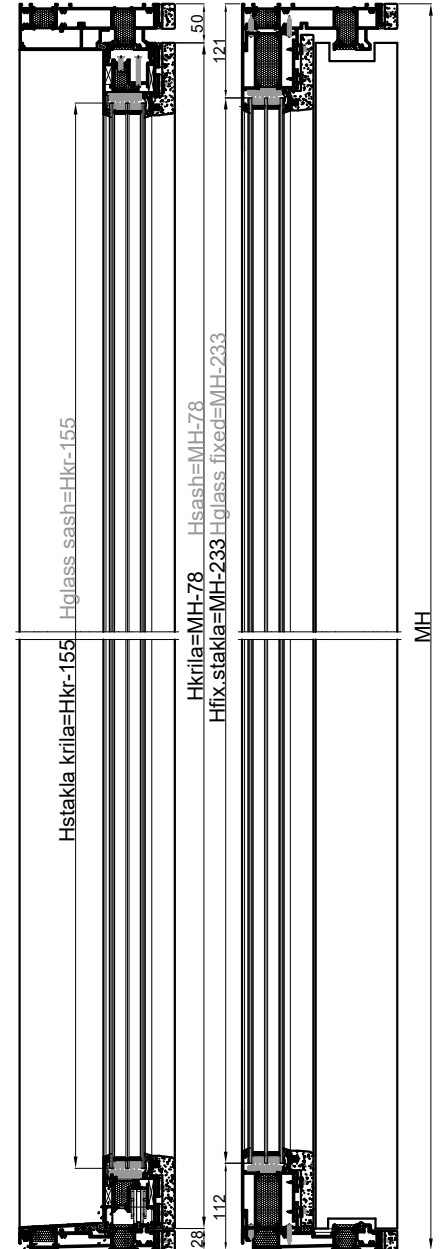
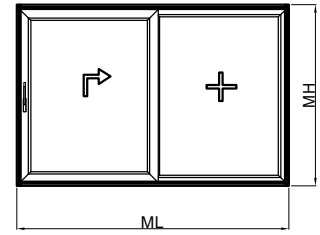

Staklo Glass	Mjera Measure
46 mm Staklo na fiksnom dijelu	Glass on the fixed part (ML/2 - 68.5) x (MH-233)
46 mm Staklo na krilu	Glass on the sash (Lkr-155) x (Hkr-155)

$$L_{prečke} = ML/2 + 68.5 \quad L_{mullion} = ML/2 + 68.5$$

$$L_{stakla\ fixnog} = ML/2 - 68.5 \quad L_{gl.\ fixed} = ML/2 - 68.5$$

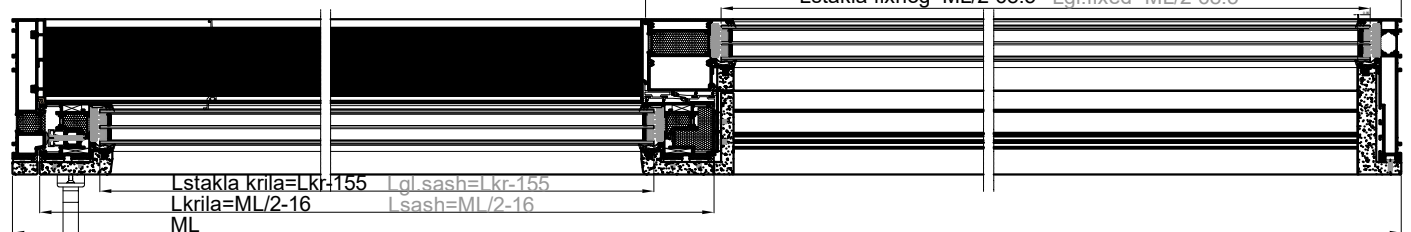

Profili	Profiles	Kom	Pcs	Mjera	Measure	Pilanje	Cutting
FT-0430F	Okomica rama - strana krila	Vertical frame profile- sash side	1	MH			90-90
FT-0431F	Okomica rama - fiksna strana	Vertical frame profile- fixed side	1	MH			90-90
FT-0433F	Vodoravnica rama - prag	Horizontal frame profile- treshold	1	Lpr=ML-60			90-90
FT-0432F	Vodoravnica rama - gornji dio	Horizontal frame profile- topside	1	Lgr=ML-60			90-90
FT-0436F	Okomica krila	Vertical sash profile	2	Hkr=MH-78			45-45
FT-0436F	Vodoravnica krila	Horizontal sash profile	2	Lkr=ML/2-16			45-45
FT-0440F	Prečka (s drvenom oblogom)	Mullion (with wooden covering)	1	Hpr=MH-60			90-90
FT-0446F	Profil umetka za fiksni dio	Insert profile -fixed	2	Lum=ML/2-45			90-90
F-1350	Vodoravna lajsna-krilo	Horizontal plate - sash	2	Llk=Lkr-187			90-90
F-1350	Okomita lajsna-krilo	Vertical plate - sash	2	Hlk=Hkr-187			90-90
F-1350	Vodoravna lajsna-fiksno	Horizontal plate - fixed	2	Llf=ML-Lkr-116			90-90
F-1350	Okomita lajsna-fiksno	Vertical plate - fixed	2	Hlf=MH-217.5			90-90
F-1414	Lajsna na ramu FT-0430F	Plate on frame FT-0430F	1	HI=MH-87			90-90
F-1415	Lajsna na krilu - uz prečku	Plate on sash - to the mullion	1	HI=MH-78			90-90
F-1416	Lajsna na prečki	Plate on mullion	1	HI=MH-87			90-90
F-1417	Lajsna na pragu	Plate on treshold	1	LI=ML/2-116.5			90-90
F-1418	Okapnica na pragu	Drip profile on treshold	1	Lo=ML-60			90-90
F-1419	Staklo lajsna - fiksni dio	Glazing bead - fixed part	1	Lfix=ML/2-98.5			90-90
F-1420	Držač drvene obloge 600.011	Wooden covering holder 600.011	1	MH			90-90
F-1421	Lajsna na ramu FT-0432F	Plate on frame FT-0432F	1	LI=ML/2-116.5			90-90
F-1428	Umetak ispod brave	Insert under the lock	1	Hu=MH-180			90-90
F-1112	Al. vodilica	Al. guide	1	Lš=ML-103			90-90
F-1649	Držač drvene obloge 600.030	Wooden covering holder 600.030	4	Lo=ML/2-100.5			90-90
Drvene obloge Wooden coverings							
600.011	Okomica uz ram FT-0430F	Vertical cover to the frame FT-0430F	1	MH			90-90
600.011	Vodoravnica uz ram FT-0432F	Horizontal cover to the frame FT-0432F	1	LI=ML-32			90-90
600.012	Obloga krila uz prečku	Sash coverings to the mullion	1	Ho=MH-78			90-90
600.013	Obloga prečke na FT-0440F	Mullion coverings on FT-0440F	1	Ho=MH-62			90-90
600.015	Obloga rama FT-0433F	Frame coverings FT-0433F	1	Lo=ML-32			90-90
600.030	Vodoravna obloga na fix.dijelu	Horizontal coverings on fix. section	2	Lo=ML/2-100.5			90-90
600.017	Vodoravnica krila	Horizontal sash profile	2	Lo=ML/2-16			45-45
600.017	Okomica krila	Vertical frame profile	2	Ho=MH-78			45-45
600.018	Okomica uz ram FT-0431F	Vertical cover to the sash FT-0431F	1	Ho=MH-57			90-90
Okovi Hardware							
710.193	Kutnik krila	Sash corner bracket	4				
710.401	Pomoćni kutnik krila	Support frame corner bracket	4				
730.017	Pomoćni kutnik krila	Support frame corner bracket	8				
730.002	Pomoćni kutnik krila	Support frame corner bracket	8				
731.010	Pomoćni kutnik krila	Support frame corner bracket	4				
Podizno-klizni mehanizam HAUTAU							
Brtve i dodatci Gaskets and accessories							
321.002	Brtva u krilu	Gasket in sash		(ML+2MH)x2			
327.003	Brtva u krilu	Gasket in sash		2Lkr+2Hkr			
344.073	Brtva na prečki	Gasket on mullion		2MH			
344.045	Brtva u krilu	Gasket in sash		(ML+2MH)x2			
344.049	Brtva prema staklu	Gasket in sash		(ML+2MH)x2			
348.061	Brtva na ramu	Gasket on frame		2ML+MH			
344.062	Brtva na ramu	Gasket on frame		ML/2			
344.063	Brtva na ramu i krilu	Gasket on frame and sash		ML+MH+2Lkr+2Hkr			
344.064	Brtva ispod lajsne na pragu	Gasket under the plate on treshold		ML/2			
344.065	Brtva na pragu	Gasket on treshold		ML			
348.067	Brtva u krilu	Gasket in sash		2Lkr			
340.013	Ispuna ispod stakla	Filling under the glass		(ML+2MH)x2			
345.010	Ublaživač udara	Bump absorber	2				
347.011	QL brtva 7mm	QL gasket 7mm		2ML+MH			
347.012	QL brtva 10mm	QL gasket 10mm		4MH			
360.009	Monodrain - izvod kapljevina	Monodrain - liquid excerpt		Lkr/400			
365.058	Set umetaka za lijeva vrata ili	Set of inserts for left door	1				
365.059	Set umetaka za desna vrata	Set of inserts for right door	1				
371.021	Set umetaka za masku krila	Set of inserts for mullion mask	1				
374.083	PVC umetak - spoj preč. i krila	PVC insert-contact of mullion and sash	1	Hkr			90-90
374.083	PVC umetak - spoj preč. i krila	PVC insert-contact of mullion and sash	1	MH-87			90-90
374.063	PVC umetak na pragu	PVC insert on treshold	1	(ML/2)-79.5			
375.048	Umetak - kopča	Insert - Clamp		(ML/600)+(4MH/300)			
375.050	Kopča za drvo	Clamp for wood		(2ML/250)+(MH/250)+(ML/200)+(3MH/200)			
373.078	Usmjerivač krila	Sash router	4				
344.044	Gumeni umetak ispod krila	Rubber insert	2				
347.009	Četkica u gornjem dijelu	Brush insert	1				

Staklo	Glass	Mjera	Measure
46 mm	Staklo na fiksnoj dijelu	Glass on the fixed part	(ML/2 - 68.5) x (MH-233)
46 mm	Staklo na krilu	Glass on the sash	(Lkr-155) x (Hkr-155)

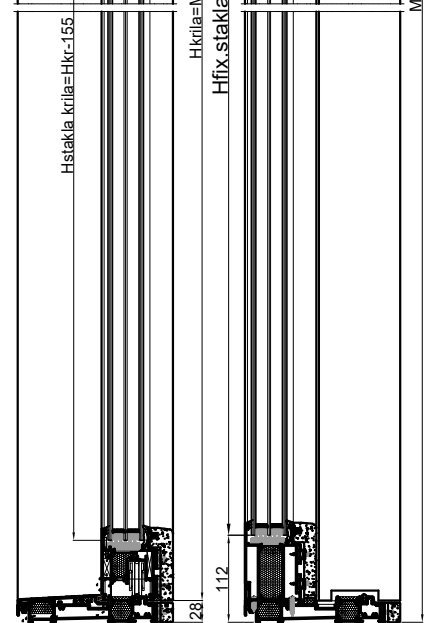
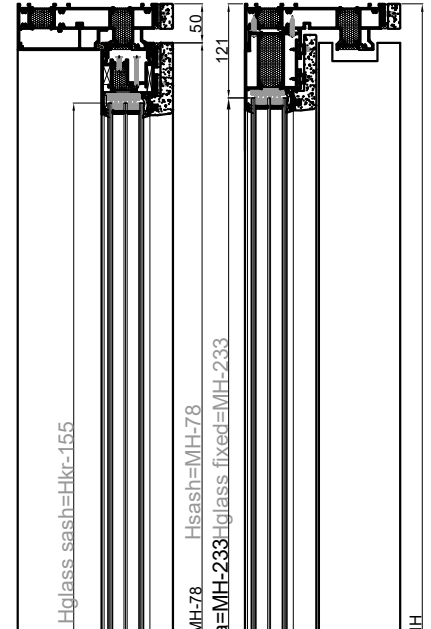
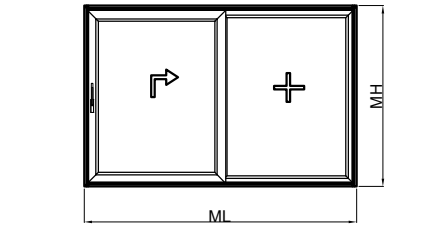
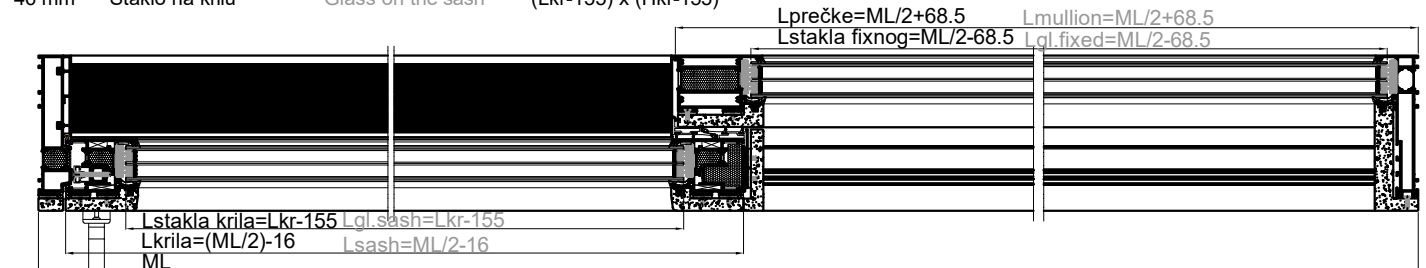

Profil Profiles	Kom Pcs	Mjera Measure	Pilanje Cutting
FT-0430F Okomica rama - strana krila	2	MH	90-90
FT-0433F Vodoravnica rama - prag	1	Lpr=ML-64	90-90
FT-0432F Vodoravnica rama - gornji dio	1	Lgr=ML-64	90-90
FT-0436F Okomica krila	4	Hkr=MH-78	45-45
FT-0436F Vodoravnica krila	4	Lkr=ML/4+12	45-45
FT-0442F Prečka (bez drvene obloge)	2	Mullion (without wooden covering)	90-90
F-1350 Vodoravna lajsna-krilo	4	Llk=Lkr-187	90-90
F-1350 Okomita lajsna-krilo	4	Hlk=Hkr-187	90-90
F-1350 Vodoravna lajsna-fiksno	2	Llf=ML-2Lkr-121	90-90
F-1350 Okomita lajsna-fiksno	2	Hlf=MH-63.5	90-90
F-1414 Lajsna na ramu FT-0430F	2	Hi=MH-87	90-90
F-1415 Lajsna na krilu - uz prečku	2	Hi=MH-78	90-90
F-1416 Lajsna na prečki	2	Hi=MH-87	90-90
F-1417 Lajsna na pragu	2	Li=ML/4-88.5	90-90
F-1418 Okapnica na pragu	1	Lo=ML-64	90-90
F-1419 Staklo lajsna - fiksni dio	1	Lfix=2Lkr-167	90-90
F-1421 Lajsna na ramu FT-0432F	2	Li=ML/4-88.5	90-90
F-1428 Umetak ispod brave	2	Hu=MH-180	90-90
F-1112 Al. vodilica	1	Lš=ML-94	90-90

Drvene obloge Wooden coverings

600.011 Okomica uz ram FT-0430F	2	MH	90-90
600.011 Vodoravnica uz ram FT-0432F	1	Li=ML-64	90-90
600.012 Obloga krila uz prečku	2	Ho=MH-78	90-90
600.016 Obloga prečke na FT-0442F	2	Ho=MH-62	90-90
600.015 Obloga rama FT-0433F	1	Lo=ML-64	90-90
600.016 Vodoravna obloga na fix. dijelu	2	Lo=2Lkr-99	90-90
600.017 Vodoravnica krila	4	Lo=ML/4+12	45-45
600.017 Okomica krila	4	Ho=MH-78	45-45

Okovi Hardware

710.193 Kutnik krila	8		
710.401 Pomoćni kutnik krila	8		
730.017 Pomoćni kutnik krila	16		
730.002 Pomoćni kutnik krila	16		
731.010 Pomoćni kutnik krila	8		

Podizno-klizni mehanizam HAUTAU

Brtve i dodatci Gaskets and accessories

321.002 Brtva u krilu		ML+2MH+4Lkr+4Hkr	
327.003 Brtva u krilu		4Lkr+4Hkr	
344.073 Brtva na prečki		4MH	
344.045 Brtva u krilu		2ML+2MH+4Lkr+4Hkr	
344.049 Brtva u krilu		ML+2MH+4Lkr+4Hkr	
348.061 Brtva na ramu		2ML+2MH	
344.062 Brtva na ramu		ML/2	
344.063 Brtva na ramu i krilu		ML+2MH+4Lkr+4Hkr	
344.064 Brtva ispod lajsne na pragu		ML/2	
344.065 Brtva na pragu		ML	
348.067 Brtva u krilu		4Lkr	
340.013 Ispuna ispod stakla		2ML+6MH	
345.010 Ublaživač udara krila	4		
347.011 QL brtva 7mm		2ML+2MH	
347.012 QL brtva 10mm		8MH	
360.009 Monodrain-izvod kapljevina		Lkr/400	
365.058 Set umetaka za lijeva vrata	1		
365.059 Set umetaka za desna vrata	1		
371.021 Set umetaka za masku preč.	2		
374.083 PVC umetak	2	Hkr	90-90
374.083 PVC umetak	2	MH-87	90-90
374.063 PVC umetak na pragu	1	ML-2Lkr-80.5	
375.048 Umetak - kopča		(ML/600)+(4MH/300)	
375.050 Kopča za drvo		(2ML/250)+(2MH/250) + (ML/200)+(3MH/100)	
373.078 Usmjerivač krila	8		
344.044 Gumeni umetak ispod krila	4		
347.009 Četkica u gornjem dijelu	2		

Staklo Glass

	Mjera Measure
46 mm Staklo na fiksnom dijelu	(2Lkr-137) x (MH-79)
46 mm Staklo na krilu	(Lkr-155) x (Hkr-155)

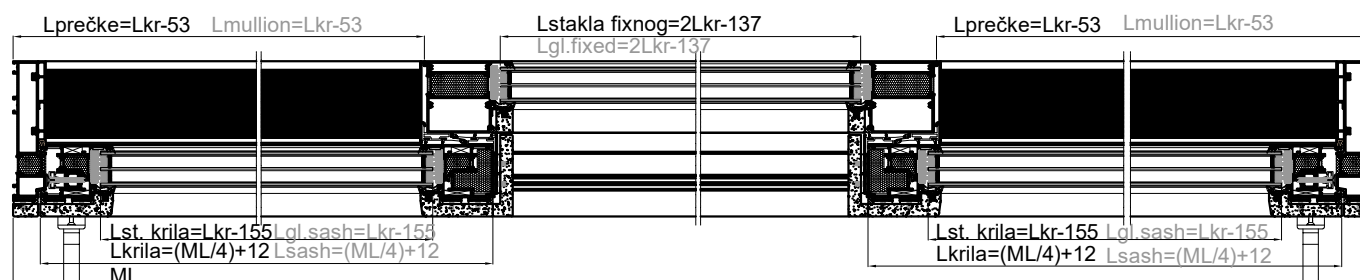
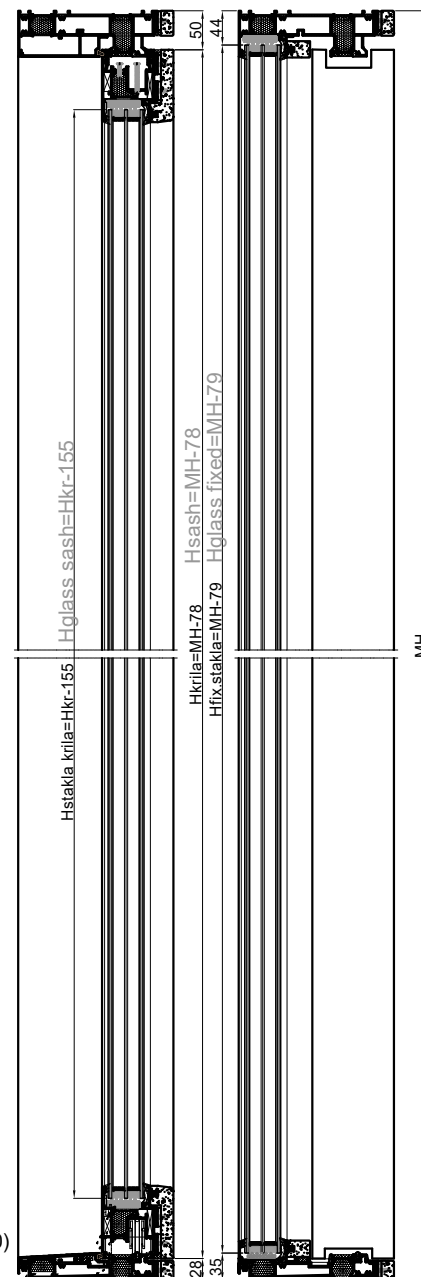
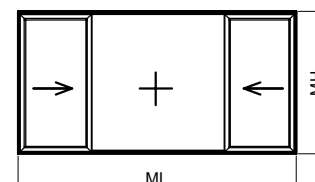

Profili Profiles		Kom Pcs	Mjera Measure	Pilanje Cutting
FT-0430F	Okomica rama - strana krila	2	MH	90-90
FT-0433F	Vodoravnica rama - prag	1	Lpr=ML-64	90-90
FT-0432F	Vodoravnica rama - gornji dio	1	Lgr=ML-64	90-90
FT-0436F	Okomica krila	4	Hkr=MH-78	45-45
FT-0436F	Vodoravnica krila	4	Lkr=ML/4+12	45-45
FT-0440F	Prečka (sa drvenom oblogom)	2	Hpr=MH-60	90-90
F-1350	Vodoravna lajsna-krilo	4	Llk=Lkr-187	90-90
F-1350	Okomita lajsna-krilo	4	Hlk=Hkr-187	90-90
F-1350	Vodoravna lajsna-fiksno	2	Llf=ML-2Lkr-121	90-90
F-1350	Okomita lajsna-fiksno	2	Hlf=MH-63.5	90-90
F-1414	Lajsna na ramu FT-0430F	2	HI=MH-87	90-90
F-1415	Lajsna na krilu - uz prečku	2	HI=MH-78	90-90
F-1416	Lajsna na prečki	2	HI=MH-87	90-90
F-1417	Lajsna na pragu	2	LI=ML/4-88.5	90-90
F-1418	Okapnica na pragu	1	Lo=ML-64	90-90
F-1419	Staklo lajsna - fiksni dio	1	Lfix=2Lkr-167	90-90
F-1421	Lajsna na ramu FT-0432F	2	LI=ML/4-88.5	90-90
F-1428	Umetak ispod brave	2	Hu=MH-180	90-90
F-1112	Al. vodilica	1	Lš=ML-94	90-90

Drvene obloge Wooden coverings

600.011	Okomica uz ram FT-0430F	2	MH	90-90
600.011	Vodoravnica uz ram FT-0432F	1	LI=ML-64	90-90
600.012	Obloga krila uz prečku	2	Ho=MH-78	90-90
600.013	Obloga prečke na FT-0440F	2	Ho=MH-62	90-90
600.015	Obloga rama FT-0433F	1	Lo=ML-64	90-90
600.016	Vod. obloga na fix. dijelu	2	Lo=2Lkr-99	90-90
600.017	Vodoravnica krila	4	Lo=ML/4+12	45-45
600.017	Okomica krila	4	Ho=MH-78	45-45

Okovi Hardware

710.193	Kutnik krila	8		
710.401	Pomoćni kutnik krila	8		
730.017	Pomoćni kutnik krila	16		
730.002	Pomoćni kutnik krila	16		
731.010	Pomoćni kutnik krila	8		
Podizno-klizni mehanizam HAUTAU				

Brtve i dodatci Gaskets and accessories

321.002	Brtva u krilu		ML+2MH+4Lkr+4Hkr	
327.003	Brtva u krilu		4Lkr+4Hkr	
344.073	Brtva na prečki		4MH	
344.045	Brtva u krilu		2ML+2MH+4Lkr+4Hkr	
344.049	Brtva u krilu		ML+2MH+4Lkr+4Hkr	
348.061	Brtva na ramu		2ML+2MH	
344.062	Brtva na ramu		ML/2	
344.063	Brtva na ramu i krilu		ML+2MH+4Lkr+4Hkr	
344.064	Brtva ispod lajsne na pragu		ML/2	
344.065	Brtva na pragu		ML	
348.067	Brtva u krilu		4Lkr	
340.013	Ispuna ispod stakla		2ML+6MH	
345.010	Ublaživač udara krila	4		
347.011	QL brtva 7mm		2ML+2MH	
347.012	QL brtva 10mm		8MH	
360.009	Monodrain - izvod kapljevina		Lkr/400	
365.058	Set umetaka za lijeva vrata	1		
365.059	Set umetaka za desna vrata	1		
371.021	Set umetaka za masku preč.	2		
374.083	PVC umetak	2	Hkr	90-90
374.083	PVC umetak	2	MH-87	90-90
374.063	PVC umetak na pragu	1	ML-2Lkr-80.5	
375.048	Umetak - kopča		(ML/600)+(4MH/300)	
375.050	Kopča za drvo		(2ML/250)+(2MH/250)+(ML/200)+(3MH/100)	
373.078	Usmjerivač krila	8		
344.044	Gumeni umetak ispod krila	4		
347.009	Četkica u gornjem dijelu	2		

Staklo Glass

			Mjera Measure
46 mm	Staklo na fiksnom dijelu	1	(2Lkr-137) x (MH-79)
46 mm	Staklo na krilu	2	(Lkr-155) x (Hkr-155)

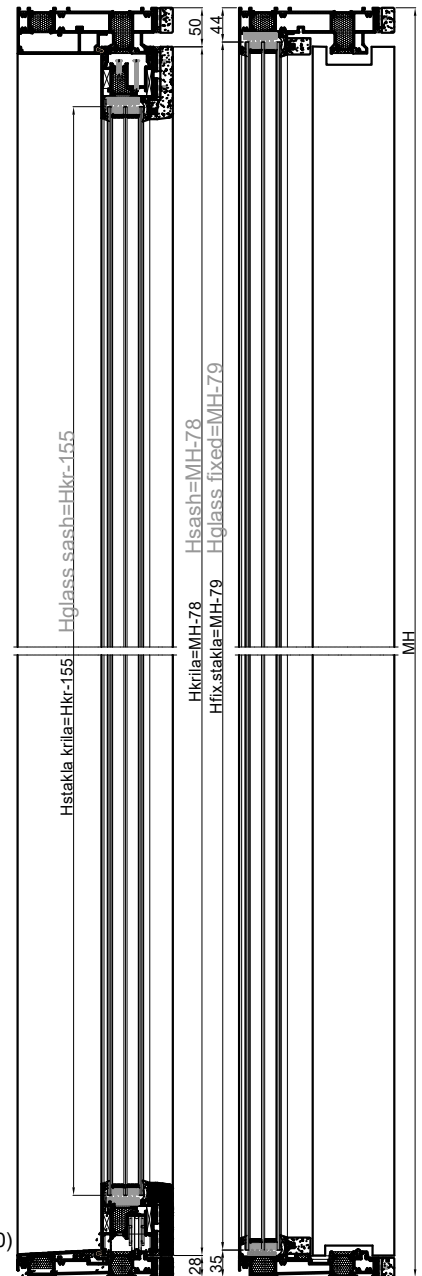
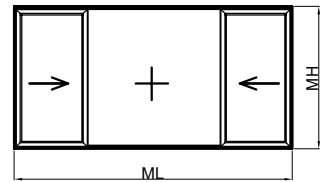

Profili	Profiles	Kom	Pcs	Mjera	Measure	Pilanje	Cutting
FT-0430F	Okomica rama - strana krila	Vertical frame profile- sash side	2	MH		90-90	
FT-0433F	Vodoravnica rama - prag	Horizontal frame profile- treshold	1	Lpr=ML-64		90-90	
FT-0432F	Vodoravnica rama - gornji dio	Horizontal frame profile- topside	1	Lgr=ML-64		90-90	
FT-0436F	Okomica krila	Vertical sash profile	4	Hkr=MH-78		45-45	
FT-0436F	Vodoravnica krila	Horizontal sash profile	4	Lkr=ML/4+12		45-45	
FT-0442F	Prečka (bez drvene obloge)	Mullion (without wooden covering)	2	Hpr=MH-60		90-90	
FT-0446F	Profil umetka za fiksni dio	Insert profile -fixed	2	Lum=2Lkr-167		90-90	
F-1350	Vodoravna lajsna-krilo	Horizontal plate - sash	4	Llk=Lkr-187		90-90	
F-1350	Okomita lajsna-krilo	Vertical plate - sash	4	Hlk=Hkr-187		90-90	
F-1350	Vodoravna lajsna-fiksno	Horizontal plate - fixed	2	Llf=ML-2Lkr-121		90-90	
F-1350	Okomita lajsna-fiksno	Vertical plate - fixed	2	Hlf=MH-217.5		90-90	
F-1414	Lajsna na ramu FT-0430F	Plate on frame FT-0430F	2	HI=MH-87		90-90	
F-1415	Lajsna na krilu - uz prečku	Plate on sash - to the mullion	2	HI=MH-78		90-90	
F-1416	Lajsna na prečki	Plate on mullion	2	HI=MH-87		90-90	
F-1417	Lajsna na pragu	Plate on treshold	2	LI=ML/4-88.5		90-90	
F-1418	Okapnica na pragu	Drip profile on treshold	1	Lo=ML-64		90-90	
F-1419	Staklo lajsna - fiksni dio	Glazing bead - fixed part	1	Lfix=2Lkr-167		90-90	
F-1421	Lajsna na ramu FT-0432F	Plate on frame FT-0432F	2	LI=ML/4-88.5		90-90	
F-1428	Umetak ispod brave	Insert under the lock	2	Hu=MH-180		90-90	
F-1112	Al. vodilica	Al. guide	1	Lš=ML-94		90-90	
F-1649	Držač drvene obloge 600.030	Wooden covering holder 600.030	4	Lo=2Lkr-169		90-90	
Drvene obloge Wooden coverings							
600.011	Okomica uz ram FT-0430F	Vertical cover to the frame FT-0430F	2	MH		90-90	
600.011	Vodoravnica uz ram FT-0432F	Horizontal cover to the frame FT-0432F	1	LI=ML-64		90-90	
600.012	Obloga krila uz prečku	Sash coverings to the mullion	2	Ho=MH-78		90-90	
600.016	Obloga prečke na FT-0442F	Mullion coverings on FT-0442F	2	Ho=MH-62		90-90	
600.015	Obloga rama FT-0433F	Frame coverings FT-0433F	1	Lo=ML-64		90-90	
600.030	Vodoravna obloga na fix. dijelu	Horizontal coverings on fix. section	2	Lo=2Lkr-99		90-90	
600.017	Vodoravnica krila	Horizontal sash profile	4	Lo=ML/4+12		45-45	
600.017	Okomica krila	Vertical frame profile	4	Ho=MH-78		45-45	
Okovi Hardware							
710.193	Kutnik krila	Sash corner bracket	8				
710.401	Pomoćni kutnik krila	Support frame corner bracket	8				
730.017	Pomoćni kutnik krila	Support frame corner bracket	16				
730.002	Pomoćni kutnik krila	Support frame corner bracket	16				
731.010	Pomoćni kutnik krila	Support frame corner bracket	8				
Podizno-klizni mehanizam HAUTAU Lift and slide mechanism HAUTAU							
Brtve i dodatci Gaskets and accessories							
321.002	Brtva u krilu	Gasket in sash		ML+2MH+4Lkr+4Hkr			
327.003	Brtva u krilu	Gasket in sash		4Lkr+4Hkr			
344.073	Brtva na prečki	Gasket on mullion		4MH			
344.045	Brtva u krilu	Gasket in sash		2ML+2MH+4Lkr+4Hkr			
344.049	Brtva u krilu	Gasket in sash		ML+2MH+4Lkr+4Hkr			
348.061	Brtva na ramu	Gasket on frame		2ML+2MH			
344.062	Brtva na ramu	Gasket on frame		ML/2			
344.063	Brtva na ramu i krilu	Gasket on frame and sash		ML+2MH+4Lkr+4Hkr			
344.064	Brtva ispod lajsne na pragu	Gasket under the plate on treshold		ML/2			
344.065	Brtva na pragu	Gasket on treshold		ML			
348.067	Brtva u krilu	Gasket in sash		4Lkr			
340.013	Ispuna ispod stakla	Filling under the glass		2ML+6MH			
345.010	Ublaživač udara krila	Absorber of sash bump	4				
347.011	QL brtva 7mm	QL gasket 7mm		2ML+2MH			
347.003	QL brtva 10mm	QL gasket 10mm		8MH			
360.009	Monodrain-izvod kapljevina	Monodrain - liquid excerpt		Lkr/400			
365.058	Set umetaka za lijeva vrata	Set of inserts for left door	1				
365.059	Set umetaka za desna vrata	Set of inserts for right door	1				
371.021	Set umetaka za masku preč.	Set of inserts for mullion mask	2				
374.083	PVC umetak	PVC insert	2	Hkr		90-90	
374.083	PVC umetak	PVC insert	2	MH-87		90-90	
374.063	PVC umetak na pragu	PVC insert on treshold	1	ML-2Lkr-80.5			
375.048	Umetak - kopča	Insert - Clamp		(ML/600)+(4MH/300)			
375.050	Kopča za drvo	Clamp for wood		(2ML/250)+(2MH/250) + (ML/200)+(3MH/100)			
373.078	Usmjerivač krila	Sash router	8				
344.044	Gumeni umetak ispod krila	Rubber insert	4				
347.009	Četkica u gornjem dijelu	Brush insert	2				
Staklo Glass							
46 mm	Staklo na fiksnom dijelu	Glass on the fixed part	1	(2Lkr-137) x (MH-233)			
46 mm	Staklo na krilu	Glass on the sash	2	(Lkr-155) x (Hkr-155)			

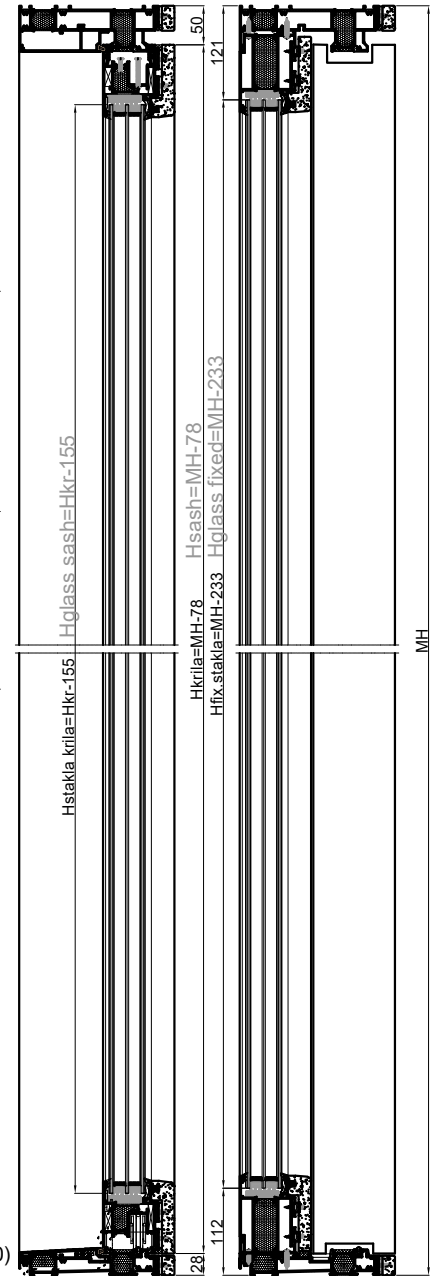

Profili	Profiles	Kom	Pcs	Mjera	Measure	Pilanje	Cutting
FT-0430F	Okomica rama - strana krila	Vertical frame profile- sash side	2	MH		90-90	
FT-0433F	Vodoravnica rama - prag	Horizontal frame profile- treshold	1	Lpr=ML-64		90-90	
FT-0432F	Vodoravnica rama - gornji dio	Horizontal frame profile- topside	1	Lgr=ML-64		90-90	
FT-0436F	Okomica krila	Vertical sash profile	4	Hkr=MH-78		45-45	
FT-0436F	Vodoravnica krila	Horizontal sash profile	4	Lkr=ML/4+12		45-45	
FT-0440F	Prečka (sa drvenom oblogom)	Mullion (with wooden covering)	2	Hpr=MH-60		90-90	
FT-0446F	Profil umetka za fiksni dio	Insert profile -fixed	2	Lum=2Lkr-167		90-90	
F-1350	Vodoravna lajsna-krilo	Horizontal plate - sash	4	Llk=Lkr-187		90-90	
F-1350	Okomita lajsna-krilo	Vertical plate - sash	4	Hlk=Hkr-187		90-90	
F-1350	Vodoravna lajsna-fiksno	Horizontal plate - fixed	2	Llf=ML-2Lkr-121		90-90	
F-1350	Okomita lajsna-fiksno	Vertical plate - fixed	2	Hlf=MH-217.5		90-90	
F-1414	Lajsna na ramu FT-0430F	Plate on frame FT-0430F	2	HI=MH-87		90-90	
F-1415	Lajsna na krilu - uz prečku	Plate on sash - to the mullion	2	HI=MH-78		90-90	
F-1416	Lajsna na prečki	Plate on mullion	2	HI=MH-87		90-90	
F-1417	Lajsna na pragu	Plate on treshold	2	LI=ML/4-88.5		90-90	
F-1418	Okapnica na pragu	Drip profile on treshold	1	Lo=ML-64		90-90	
F-1419	Staklo lajsna - fiksni dio	Glazing bead - fixed part	1	Lfix=2Lkr-167		90-90	
F-1421	Lajsna na ramu FT-0432F	Plate on frame FT-0432F	2	LI=ML/4-88.5		90-90	
F-1428	Umetak ispod brave	Insert under the lock	2	Hu=MH-180		90-90	
F-1112	Al. vodilica	Al. guide	1	Lš=ML-94		90-90	
F-1649	Držač drvene obloge 600.030	Wooden covering holder 600.030	4	Lo=2Lkr-169		90-90	
Drvene obloge Wooden coverings							
600.011	Okomica uz ram FT-0430F	Vertical cover to the frame FT-0430F	2	MH		90-90	
600.011	Vodoravnica uz ram FT-0432F	Horizontal cover to the frame FT-0432F	2	LI=ML-64		90-90	
600.012	Obloga krila uz prečku	Sash coverings to the mullion	2	Ho=MH-78		90-90	
600.013	Obloga prečke na FT-0440F	Mullion coverings on FT-0440F	2	Ho=MH-62		90-90	
600.015	Obloga rama FT-0433F	Frame coverings FT-0433F	1	Lo=ML-64		90-90	
600.030	Vod. obloga na fix.dijelu	Horizontal coverings on fix. section	2	Lo=2Lkr-99		90-90	
600.017	Vodoravnica krila	Horizontal sash profile	4	Lo=ML/4+12		45-45	
600.017	Okomica krila	Vertical frame profile	4	Ho=MH-78		45-45	
Okovi Hardware							
710.193	Kutnik krila	Sash corner bracket	8				
710.401	Pomoćni kutnik krila	Support frame corner bracket	8				
730.017	Pomoćni kutnik krila	Support frame corner bracket	16				
730.002	Pomoćni kutnik krila	Support frame corner bracket	16				
731.010	Pomoćni kutnik krila	Support frame corner bracket	8				
Podizno-klizni mehanizam HAUTAU Lift and slide mechanism HAUTAU							
Brtve i dodatci Gaskets and accessories							
321.002	Brtva u krilu	Gasket in sash		ML+2MH+4Lkr+4Hkr			
327.003	Brtva u krilu	Gasket in sash		4Lkr+4Hkr			
344.073	Brtva na prečki	Gasket on mullion		4MH			
344.045	Brtva u krilu	Gasket in sash		2ML+2MH+4Lkr+4Hkr			
344.049	Brtva u krilu	Gasket in sash		ML+2MH+4Lkr+4Hkr			
348.061	Brtva na ramu	Gasket on frame		2ML+2MH			
344.062	Brtva na ramu	Gasket on frame		ML/2			
344.063	Brtva na ramu i krilu	Gasket on frame and sash		ML+2MH+4Lkr+4Hkr			
344.064	Brtva ispod lajsne na pragu	Gasket under the plate on treshold		ML/2			
344.065	Brtva na pragu	Gasket on treshold		ML			
348.067	Brtva u krilu	Gasket in sash		4Lkr			
340.013	Ispuna ispod stakla	Filling under the glass		2ML+6MH			
345.010	Ublaživač udara krila	Absorber of sash bump	4				
347.011	QL brtva 7mm	QL gasket 7mm		2ML+2MH			
347.012	QL brtva 10mm	QL gasket 10mm		8MH			
360.009	Monodrain - izvod kapljevina	Monodrain - liquid excerpt		Lkr/400			
365.058	Set umetaka za lijeva vrata	Set of inserts for left door	1				
365.059	Set umetaka za desna vrata	Set of inserts for right door	1				
371.021	Set umetaka za masku preč.	Set of inserts for mullion mask	2				
374.083	PVC umetak	PVC insert	2	Hkr	90-90		
374.083	PVC umetak	PVC insert	2	MH-87	90-90		
374.063	PVC umetak na pragu	PVC insert on treshold	1	ML-2Lkr-80.5			
375.048	Umetak - kopča	Insert - Clamp		(ML/600)+(4MH/300)			
375.050	Kopča za drvo	Clamp for wood		(2ML/250)+(2MH/250)+(ML/200)+(3MH/100)			
373.078	Usmjerivač krila	Sash router	8				
344.044	Gumeni umetak ispod krila	Rubber insert	4				
347.009	Četkica u gornjem dijelu	Brush insert	2				
Staklo Glass							
46 mm	Staklo na fiksnom dijelu	Glass on the fixed part	1	(2Lkr-137) x (MH-79)			
46 mm	Staklo na krilu	Glass on the sash	2	(Lkr-155) x (Hkr-155)			

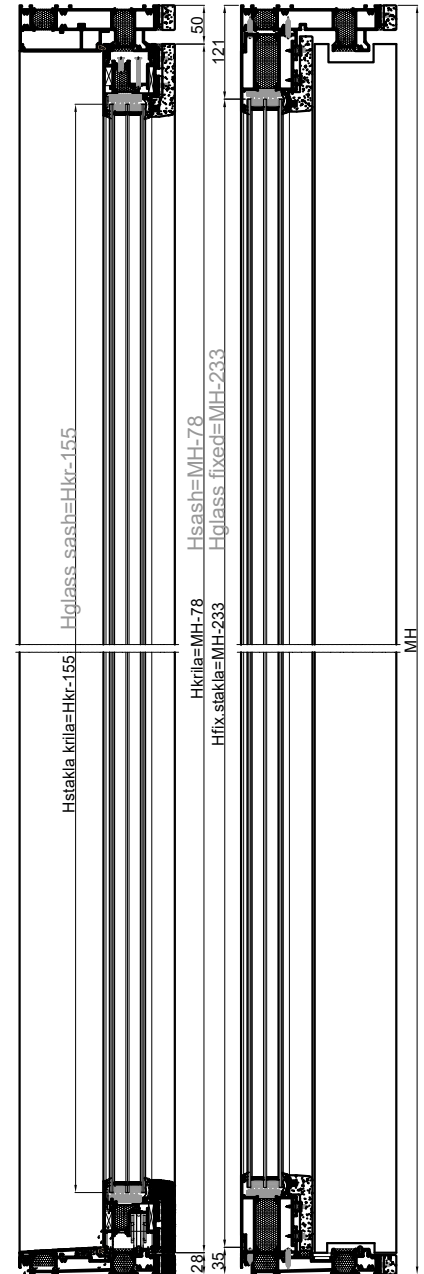

Profili Profiles		Kom Pcs	Mjera Measure	Pilanje Cutting
FT-0431F Okomica rama	Vertical frame profile	2	MH	90-90
FT-0433F Vodoravnica rama - prag	Horizontal frame profile- treshold	1	Lpr=ML-56	90-90
FT-0432F Vodoravnica rama - gornji dio	Horizontal frame profile- topside	1	Lgr=ML-56	90-90
FT-0436F Okomica krila	Vertical sash profile	4	Hkr=MH-78	45-45
FT-0436F Vodoravnica krila	Horizontal sash profile	4	Lkr=ML/4	45-45
FT-0441 Okomiti dodatak krila	Vertical sash addition	1	Hkr=MH-78	90-90
FT-0442F Prečka (bez drvene obloge)	Mullion (without wooden covering)	2	Hpr=MH-60	90-90
F-1350 Vodoravna lajsna-krilo	Horizontal plate - sash	4	Llk=Lkr-187	90-90
F-1350 Okomita lajsna-krilo	Vertical plate - sash	4	Hlk=Hkr-187	90-90
F-1350 Vodoravna lajsna-fiksno	Horizontal plate - fixed	4	Llf=(ML/2)-Lkr-84	90-90
F-1350 Okomita lajsna-fiksno	Vertical plate - fixed	4	Hlf=MH-63.5	90-90
F-1415 Lajsna na krilu - uz prečku	Plate on sash - to the mullion	2	HI=MH-78	90-90
F-1416 Lajsna na prečki	Plate on mullion	2	HI=MH-87	90-90
F-1417 Lajsna na pragu	Plate on treshold	1	LI=2Lkr-182	90-90
F-1418 Okapnica na pragu	Drip profile on treshold	1	Lo=ML-56	90-90
F-1419 Staklo lajsna - fiksni dio	Glazing bead - fixed part	2	Lfix=ML/4-82	90-90
F-1420 Držač drvene obloge 600.011	Wooden covering holder 600.011	2	MH	90-90
F-1421 Lajsna na ramu FT-0432F	Plate on frame FT-0432F	2	LI=ML/2-181	90-90
F-1428 Umetak ispod brave	Insert under the lock	2	Hu=MH-180	90-90
F-1112 Al. vodilica	Al. guide	1	Lš=ML-112	90-90
Drvene obloge Wooden coverings				
600.018 Okomica uz ram FT-0431F	Vertical cover to the frame FT-0431F	2	MH-57	90-90
600.011 Vodoravnica uz ram FT-0432F	Horizontal cover to the frame FT-0432F	1	LI=ML	90-90
600.012 Obloga krila uz prečku	Sash coverings to the mullion	2	Ho=MH-78	90-90
600.016 Obloga prečke na FT-0442F	Mullion coverings on FT-0442F	2	Ho=MH-62	90-90
600.015 Obloga rama FT-0433F	Frame coverings FT-0433F	1	Lo=ML	90-90
600.016 Vodoravna obloga na fix. dijelu	Horizontal coverings on fix. section	4	Lo=ML/4-84	90-90
600.017 Vodoravnica krila	Horizontal sash profile	4	Lo=ML/4	45-45
600.017 Okomica krila	Vertical frame profile	4	Ho=MH-78	45-45
Okovi Hardware				
710.193 Kutnik krila	Sash corner bracket	8		
710.401 Pomoćni kutnik krila	Support frame corner bracket	8		
730.017 Pomoćni kutnik krila	Support frame corner bracket	16		
730.002 Pomoćni kutnik krila	Support frame corner bracket	16		
731.010 Pomoćni kutnik krila	Support frame corner bracket	8		
Podizno-klizni mehanizam HAUTAU	Lift and slide mechanism HAUTAU			
Brtve i dodatci Gaskets and accessories				
321.002 Brtva u krilu	Gasket in sash		2ML+8MH	
327.003 Brtva u krilu	Gasket in sash		4Lkr+2Hkr	
344.073 Brtva na prečki	Gasket on mullion		4MH	
344.045 Brtva u krilu	Gasket in sash		2ML+8MH	
344.049 Brtva u krilu	Gasket in sash		2ML+8MH	
348.061 Brtva na ramu	Gasket on frame		2ML	
344.062 Brtva na ramu	Gasket on frame		ML/2	
344.063 Brtva na ramu i krilu	Gasket on frame and sash		2ML+6MH	
344.064 Brtva ispod lajsne na pragu	Gasket under the plate on treshold		ML/2	
344.065 Brtva na pragu	Gasket on treshold		ML	
348.067 Brtva u krilu	Gasket in sash		4Lkr	
340.013 Ispuna ispod stakla	Filling under the glass		2ML+8MH	
345.010 Ublaživač udara krila	Absorber of sash bump	4		
347.011 QL brtva 7mm	QL gasket 7mm		2ML	
347.012 QL brtva 10mm	QL gasket 10mm		8MH	
360.009 Monodrain - izvod kapljevina	Monodrain - liquid excerpt		Lkr/400	
371.021 Set umetaka za masku preč.	Set of inserts for mullion mask	2		
374.083 PVC umetak	PVC insert	2	Hkr	90-90
374.083 PVC umetak	PVC insert	2	MH-87	90-90
374.063 PVC umetak na pragu	PVC insert on treshold	2	(ML/2)-Lkr-63.5	
375.048 Umetak - kopča	Insert - Clamp		(ML/600)+(4MH/300)	
375.050 Kopča za drvo	Clamp for wood		(2ML/250)+(ML/200)+(3MH/100)	
373.078 Usmjerivač krila	Sash router	8		
344.044 Gumeni umetak ispod krila	Rubber insert	4		
347.009 Četkica u gornjem dijelu	Brush insert	2		
363.030 Gumeni umetak za FT-0441	Rubber insert for FT-0441	2		
Staklo Glass				
46 mm Staklo na fiksnoj dijelu	Glass on the fixed part	2	(ML/4-52) x (MH-79)	
46 mm Staklo na krilu	Glass on the sash	2	(Lkr-155) x (Hkr-155)	

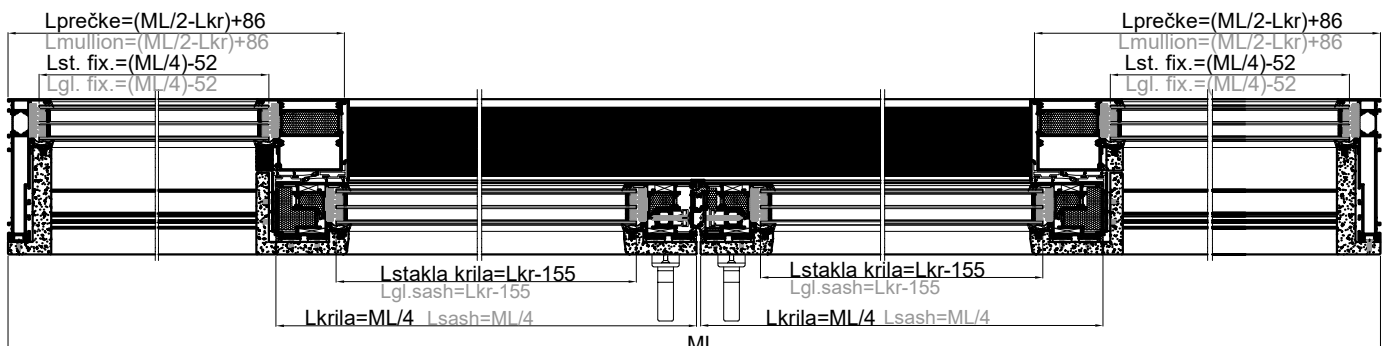
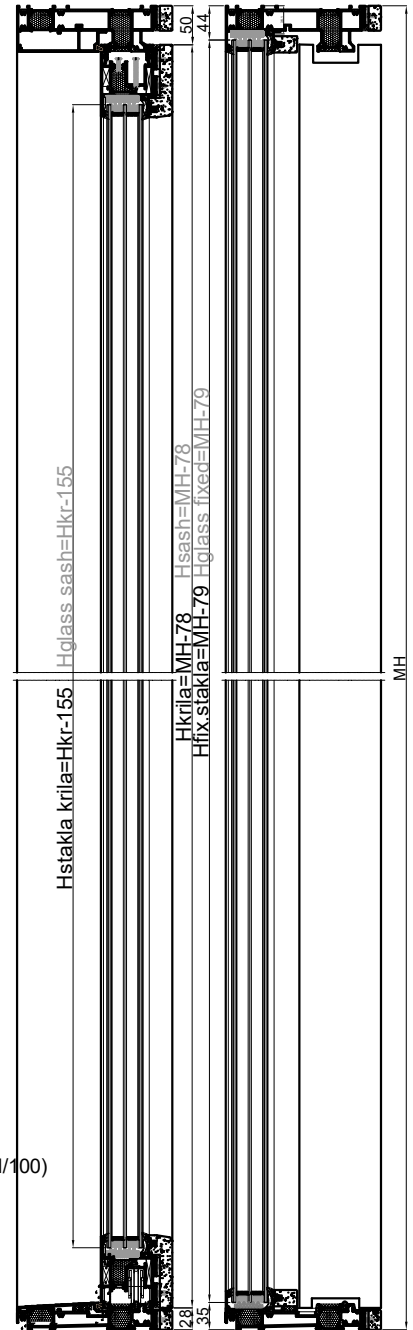
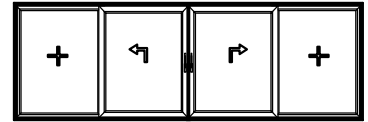

Profili Profiles		Kom Pcs	Mjera Measure	Pilanje Cutting
FT-0431F Okomica rama - strana krila	Vertical frame profile	2	MH	90-90
FT-0433F Vodoravnica rama - prag	Horizontal frame profile- treshold	1	Lpr=ML-56	90-90
FT-0432F Vodoravnica rama - gornji dio	Horizontal frame profile- topside	1	Lgr=ML-56	90-90
FT-0436F Okomica krila	Vertical sash profile	4	Hkr=MH-78	45-45
FT-0436F Vodoravnica krila	Horizontal sash profile	4	Lkr=ML/4	45-45
FT-0441 Okomiti dodatak krila	Vertical sash addition	1	Hkr=MH-78	90-90
FT-0440F Prečka	Mullion	2	Hpr=MH-60	90-90
F-1350 Vodoravna lajsna-krilo	Horizontal plate - sash	4	Llk=Lkr-187	90-90
F-1350 Okomita lajsna-krilo	Vertical plate - sash	4	Hlk=Hkr-187	90-90
F-1350 Vodoravna lajsna-fiksno	Horizontal plate - fixed	4	Llf=(ML/2)-Lkr-84	90-90
F-1350 Okomita lajsna-fiksno	Vertical plate - fixed	4	Hlf=MH-63.5	90-90
F-1415 Lajsna na krilu - uz prečku	Plate on sash - to the mullion	2	HI=MH-78	90-90
F-1416 Lajsna na prečki	Plate on mullion	2	HI=MH-87	90-90
F-1417 Lajsna na pragu	Plate on treshold	1	LI=2Lkr-182	90-90
F-1418 Okapnica na pragu	Drip profile on treshold	1	Lo=ML-56	90-90
F-1419 Staklo lajsna - fiksni dio	Glazing bead - fixed part	2	Lfix=ML/4-82	90-90
F-1420 Držač drvene obloge 600.011	Wooden covering holder 600.011	2	MH	90-90
F-1421 Lajsna na ramu FT-0432F	Plate on frame FT-0432F	2	LI=ML/2-181	90-90
F-1428 Umetak ispod brave	Insert under the lock	2	Hu=MH-180	90-90
F-1112 Al. vodilica	Al. guide	1	Lš=ML-112	90-90
Drvene obloge Wooden coverings				
600.018 Okomica uz ram FT-0431F	Vertical cover to the frame FT-0431F	2	MH-57	90-90
600.011 Vodoravnica uz ram FT-0432F	Horizontal cover to the frame FT-0432F	1	LI=ML	90-90
600.012 Obloga krila uz prečku	Sash coverings to the mullion	2	Ho=MH-78	90-90
600.013 Obloga prečke na FT-0440F	Mullion coverings on FT-0440F	2	Ho=MH-62	90-90
600.015 Obloga rama FT-0433F	Frame coverings FT-0433F	1	Lo=ML	90-90
600.016 Vodoravna obloga na fix.dijelu	Horizontal coverings on fix. section	4	Lo=ML/4-84	90-90
600.017 Vodoravnica krila	Horizontal sash profile	4	Lo=ML/4	45-45
600.017 Okomica krila	Vertical frame profile	4	Ho=MH-78	45-45
Okovi Hardware				
710.193 Kutnik krila	Sash corner bracket	8		
710.401 Pomoćni kutnik krila	Support frame corner bracket	8		
730.017 Pomoćni kutnik krila	Support frame corner bracket	16		
730.002 Pomoćni kutnik krila	Support frame corner bracket	16		
731.010 Pomoćni kutnik krila	Support frame corner bracket	8		
Podizno-klizni mehanizam HAUTAU Lift and slide mechanism HAUTAU				
Brtve i dodatci Gaskets and accessories				
321.002 Brtva u krilu	Gasket in sash		2ML+8MH	
327.003 Brtva u krilu	Gasket in sash		4Lkr+2Hkr	
344.073 Brtva na prečki	Gasket on mullion		4MH	
344.045 Brtva u krilu	Gasket in sash		2ML+8MH	
344.049 Brtva u krilu	Gasket in sash		2ML+8MH	
348.061 Brtva na ramu	Gasket on frame		2ML	
344.062 Brtva na ramu	Gasket on frame		ML/2	
344.063 Brtva na ramu i krilu	Gasket on frame and sash		2ML+6MH	
344.064 Brtva ispod lajsne na pragu	Gasket under the plate on treshold		ML/2	
344.065 Brtva na pragu	Gasket on treshold		ML	
348.067 Brtva u krilu	Gasket in sash		4Lkr	
340.013 Ispuna ispod stakla	Filling under the glass		2ML+8MH	
345.010 Ublaživač udara krila	Absorber of sash bump	4		
347.011 QL brtva 7mm	QL gasket 7mm		2ML	
347.012 QL brtva 10mm	QL gasket 10mm		8MH	
360.009 Monodrain - izvod kapljevina	Monodrain - liquid excerpt		Lkr/400	
371.021 Set umetaka za masku preč.	Set of inserts for mullion mask	2		
374.083 PVC umetak	PVC insert	2	Hkr	90-90
374.083 PVC umetak	PVC insert	2	MH-87	90-90
374.063 PVC umetak na pragu	PVC insert on treshold	2	(ML/2)-Lkr-63.5	
375.048 Umetak - kopča	Insert - Clamp		(ML/600)+(4MH/300)	
375.050 Kopča za drvo	Clamp for wood		(2ML/250)+(ML/200)+(3MH/100)	
373.078 Usmjerivač krila	Sash router	8		
344.044 Gumeni umetak ispod krila	Rubber insert	4		
347.009 Četkica u gornjem dijelu	Brush insert	2		
363.030 Gumeni umetak za FT-0441	Rubber insert for FT-0441	2		
Staklo Glass				
46 mm Staklo na fiksnoj dijelu	Glass on the fixed part	2	Mjera Measure (ML/4-52) x (MH-79)	
46 mm Staklo na krilu	Glass on the sash	2	(Lkr-155) x (Hkr-155)	

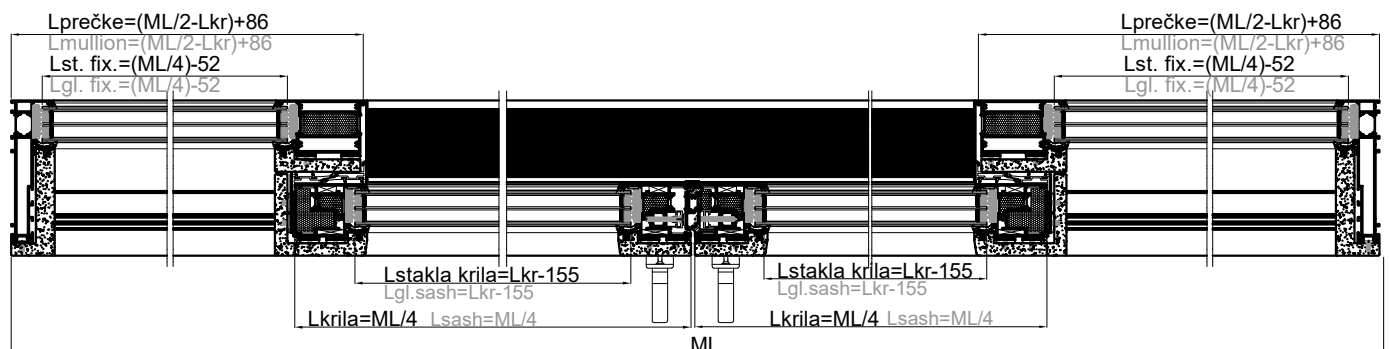
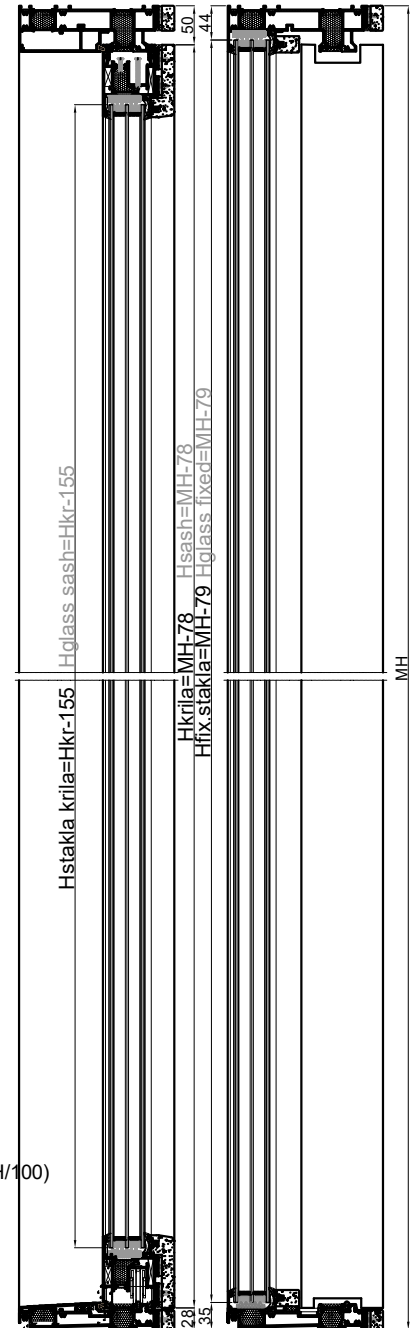
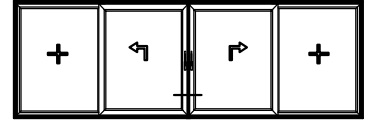

Profili Profiles		KomPcs	Mjera Measure	Pilanje Cutting
FT-0431F Okomica rama	Vertical frame profile	2	MH	90-90
FT-0433F Vodoravnica rama - prag	Horizontal frame profile- treshold	1	Lpr=ML-56	90-90
FT-0432F Vodoravnica rama - gornji dio	Horizontal frame profile- topside	1	Lgr=ML-56	90-90
FT-0436F Okomica krila	Vertical sash profile	4	Hkr=MH-78	45-45
FT-0436F Vodoravnica krila	Horizontal sash profile	4	Lkr=ML/4	45-45
FT-0441 Okomiti dodatak krila	Vertical sash addition	1	Hkr=MH-78	90-90
FT-0442F Prečka (bez drvene obloge)	Mullion (without wooden covering)	2	Hpr=MH-60	90-90
FT-0446F Profil umetka za fiksni dio	Insert profile -fixed	4	Lum=ML/4-27.5	90-90
F-1350 Vodoravna lajsna-krilo	Horizontal plate - sash	4	Llk=Lkr-187	90-90
F-1350 Okomita lajsna-krilo	Vertical plate - sash	4	Hlk=Hkr-187	90-90
F-1350 Vodoravna lajsna-fiksno	Horizontal plate - fixed	4	Llf=(ML/2)-Lkr-84	90-90
F-1350 Okomita lajsna-fiksno	Vertical plate - fixed	4	Hlf=MH-217.5	90-90
F-1415 Lajsna na krilu - uz prečku	Plate on sash - to the mullion	2	HI=MH-78	90-90
F-1416 Lajsna na prečki	Plate on mullion	2	HI=MH-87	90-90
F-1417 Lajsna na pragu	Plate on treshold	1	LI=2Lkr-182	90-90
F-1418 Okapnica na pragu	Drip profile on treshold	1	Lo=ML-56	90-90
F-1419 Staklo lajsna - fiksni dio	Glazing bead - fixed part	2	Lfix=ML/4-82	90-90
F-1420 Držač drvene obloge 600.011	Wooden covering holder 600.011	2	MH	90-90
F-1421 Lajsna na ramu FT-0432F	Plate on frame FT-0432F	2	LI=ML/2-181	90-90
F-1428 Umetak ispod brave	Insert under the lock	2	Hu=MH-180	90-90
F-1112 Al. vodilica	Al. guide	1	Lš=ML-112	90-90
F-1649 Držač drvene obloge 600.030	Wooden covering holder 600.030	8	Lo=ML/4-84	90-90
Drvene obloge Wooden coverings				
600.018 Okomica uz ram FT-0431F	Vertical cover to the frame FT-0431F	2	MH-57	90-90
600.011 Vodoravnica uz ram FT-0432F	Horizontal cover to the frame FT-0432F	1	LI=ML	90-90
600.012 Obloga krila uz prečku	Sash coverings to the mullion	2	Ho=MH-78	90-90
600.016 Obloga prečke na FT-0442F	Mullion coverings on FT-0442F	2	Ho=MH-62	90-90
600.015 Obloga rama FT-0433F	Frame coverings FT-0433F	1	Lo=ML	90-90
600.030 Vodoravna obloga na fix.dijelu	Horizontal coverings on fix. section	4	Lo=ML/4-84	90-90
600.017 Vodoravnica krila	Horizontal sash profile	4	Lo=ML/4	45-45
600.017 Okomica krila	Vertical frame profile	4	Ho=MH-78	45-45
Okovi Hardware				
710.193 Kutnik krila	Sash corner bracket	8		
710.401 Pomoćni kutnik krila	Support frame corner bracket	8		
730.017 Pomoćni kutnik krila	Support frame corner bracket	16		
730.002 Pomoćni kutnik krila	Support frame corner bracket	16		
731.010 Pomoćni kutnik krila	Support frame corner bracket	8		
Podizno-klizni mehanizam HAUTAU	Lift and slide mechanism HAUTAU			
Brtve i dodatci Gaskets and accessories				
321.002 Brtva u krilu	Gasket in sash		2ML+8MH	
327.003 Brtva u krilu	Gasket in sash		4Lkr+2Hkr	
344.073 Brtva na prečki	Gasket on mullion		4MH	
344.045 Brtva u krilu	Gasket in sash		2ML+8MH	
344.049 Brtva u krilu	Gasket in sash		2ML+8MH	
348.061 Brtva na ramu	Gasket on frame		2ML	
344.062 Brtva na ramu	Gasket on frame		ML/2	
344.063 Brtva na ramu i krilu	Gasket on frame and sash		2ML+6MH	
344.064 Brtva ispod lajsne na pragu	Gasket under the plate on treshold		ML/2	
344.065 Brtva na pragu	Gasket on treshold		ML	
348.067 Brtva u krilu	Gasket in sash		4Lkr	
340.013 Ispuna ispod stakla	Filling under the glass		2ML+8MH	
345.010 Ublaživač udara krila	Absorber of sash bump	4		
347.011 QL brtva 7mm	QL gasket 7mm		2ML	
347.012 QL brtva 10mm	QL gasket 10mm		8MH	
360.009 Monodrain - izvod kapljevina	Monodrain - liquid excerpt		Lkr/400	
371.021 Set umetaka za masku preč.	Set of inserts for mullion mask	2		
374.083 PVC umetak	PVC insert	2	Hkr	90-90
374.083 PVC umetak	PVC insert	2	MH-87	90-90
374.063 PVC umetak na pragu	PVC insert on treshold	2	(ML/2)-Lkr-63.5	
375.048 Umetak - kopča	Insert - Clamp		(ML/600)+(4MH/300)	
375.050 Kopča za drvo	Clamp for wood		(2ML/250)+(ML/200)+(3MH/100)	
373.078 Usmjerivač krila	Sash router	8		
344.044 Gumeni umetak ispod krila	Rubber insert	4		
347.009 Četkica u gornjem dijelu	Brush insert	2		
363.030 Gumeni umetak za FT-0441	Rubber insert for FT-0441	2		
Staklo Glass				
46 mm	Staklo na fiksnom dijelu	2	(ML/4-52) x (MH-233)	
46 mm	Staklo na krilu	2	(Lkr-155) x (Hkr-155)	

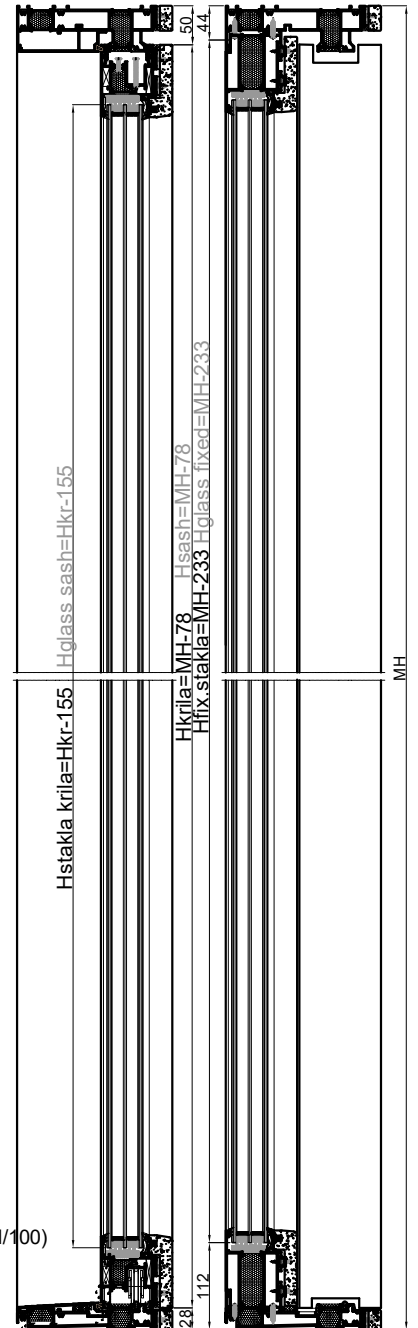
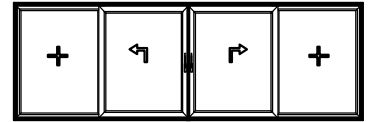

Profili Profiles		Kom	Pcs	Mjera Measure	Pilanje Cutting
FT-0431F	Okomica rama - strana krila	Vertical frame profile	2	MH	90-90
FT-0433F	Vodoravnica rama - prag	Horizontal frame profile- treshold	1	Lpr=ML-56	90-90
FT-0432F	Vodoravnica rama - gornji dio	Horizontal frame profile- topside	1	Lgr=ML-56	90-90
FT-0436F	Okomica krila	Vertical sash profile	4	Hkr=MH-78	45-45
FT-0436F	Vodoravnica krila	Horizontal sash profile	4	Lkr=ML/4	45-45
FT-0441	Okomiti dodatak krila	Vertical sash addition	1	Hkr=MH-78	90-90
FT-0440F	Prečka	Mullion	2	Hpr=MH-60	90-90
FT-0446F	Profil umetka za fiksni dio	Insert profile -fixed	4	Lum=ML/4-27.5	90-90
F-1350	Vodoravna lajsna-krilo	Horizontal plate - sash	4	Llk=Lkr-187	90-90
F-1350	Okomita lajsna-krilo	Vertical plate - sash	4	Hlk=Hkr-187	90-90
F-1350	Vodoravna lajsna-fiksno	Horizontal plate - fixed	4	Llf=(ML/2)-Lkr-84	90-90
F-1350	Okomita lajsna-fiksno	Vertical plate - fixed	4	Hlf=MH-63.5	90-90
F-1415	Lajsna na krilu - uz prečku	Plate on sash - to the mullion	2	HI=MH-78	90-90
F-1416	Lajsna na prečki	Plate on mullion	2	HI=MH-87	90-90
F-1417	Lajsna na pragu	Plate on treshold	1	LI=2Lkr-182	90-90
F-1418	Okapnica na pragu	Drip profile on treshold	1	Lo=ML-56	90-90
F-1419	Staklo lajsna - fiksni dio	Glazing bead - fixed part	2	Lfix=ML/4-82	90-90
F-1420	Držač drvene obloge 600.011	Wooden covering holder 600.011	2	MH	90-90
F-1421	Lajsna na ramu FT-0432F	Plate on frame FT-0432F	2	LI=ML/2-181	90-90
F-1428	Umetak ispod brave	Insert under the lock	2	Hu=MH-180	90-90
F-1112	Al. vodilica	Al. guide	1	Lš=ML-112	90-90
F-1649	Držač drvene obloge 600.030	Wooden covering holder 600.030	8	Lo=ML/4-84	90-90
Drvene obloge Wooden coverings					
600.018	Okomica uz ram FT-0431F	Vertical cover to the frame FT-0431F	2	MH-57	90-90
600.011	Vodoravnica uz ram FT-0432F	Horizontal cover to the frame FT-0432F	1	LI=ML	90-90
600.012	Obloga krila uz prečku	Sash coverings to the mullion	2	Ho=MH-78	90-90
600.013	Obloga prečke na FT-0440F	Mullion coverings on FT-0440F	2	Ho=MH-62	90-90
600.015	Obloga rama FT-0433F	Frame coverings FT-0433F	1	Lo=ML	90-90
600.030	Vodoravna obloga na fix. dijelu	Horizontal coverings on fix. section	4	Lo=ML/4-84	90-90
600.017	Vodoravnica krila	Horizontal sash profile	4	Lo=ML/4	45-45
600.017	Okomica krila	Vertical frame profile	4	Ho=MH-78	45-45
Okovi Hardware					
710.193	Kutnik krila	Sash corner bracket	8		
710.401	Pomoćni kutnik krila	Support frame corner bracket	8		
730.017	Pomoćni kutnik krila	Support frame corner bracket	16		
730.002	Pomoćni kutnik krila	Support frame corner bracket	16		
731.010	Pomoćni kutnik krila	Support frame corner bracket	8		
Podizno-klizni mehanizam HAUTAU Lift and slide mechanism HAUTAU					
Brtve i dodatci Gaskets and accessories					
321.002	Brtva u krilu	Gasket in sash		2ML+8MH	
327.003	Brtva u krilu	Gasket in sash		4Lkr+2Hkr	
344.073	Brtva na prečki	Gasket on mullion		4MH	
344.045	Brtva u krilu	Gasket in sash		2ML+8MH	
344.049	Brtva u krilu	Gasket in sash		2ML+8MH	
348.061	Brtva na ramu	Gasket on frame		2ML	
344.062	Brtva na ramu	Gasket on frame		ML/2	
344.063	Brtva na ramu i krilu	Gasket on frame and sash		2ML+6MH	
344.064	Brtva ispod lajsne na pragu	Gasket under the plate on treshold		ML/2	
344.065	Brtva na pragu	Gasket on treshold		ML	
348.067	Brtva u krilu	Gasket in sash		4Lkr	
340.013	Ispuna ispod stakla	Filling under the glass		2ML+8MH	
345.010	Ublaživač udara krila	Absorber of sash bump	4		
347.011	QL brtva 7mm	QL gasket 7mm		2ML	
347.012	QL brtva 10mm	QL gasket 10mm		8MH	
360.009	Monodrain - izvod kapljevina	Monodrain - liquid excerpt		Lkr/400	
371.021	Set umetaka za masku preč.	Set of inserts for mullion mask	2		
374.083	PVC umetak	PVC insert	2	Hkr	90-90
374.083	PVC umetak	PVC insert	2	MH-87	90-90
374.063	PVC umetak na pragu	PVC insert on treshold	2	(ML/2)-Lkr-63.5	
375.048	Umetak - kopča	Insert - Clamp		(ML/600)+(4MH/300)	
375.050	Kopča za drvo	Clamp for wood		(2ML/250)+(ML/200)+(3MH/100)	
373.078	Usmjerivač krila	Sash router	8		
344.044	Gumeni umetak ispod krila	Rubber insert	4		
347.009	Četkica u gornjem dijelu	Brush insert	2		
363.030	Gumeni umetak za FT-0441	Rubber insert for FT-0441	2		

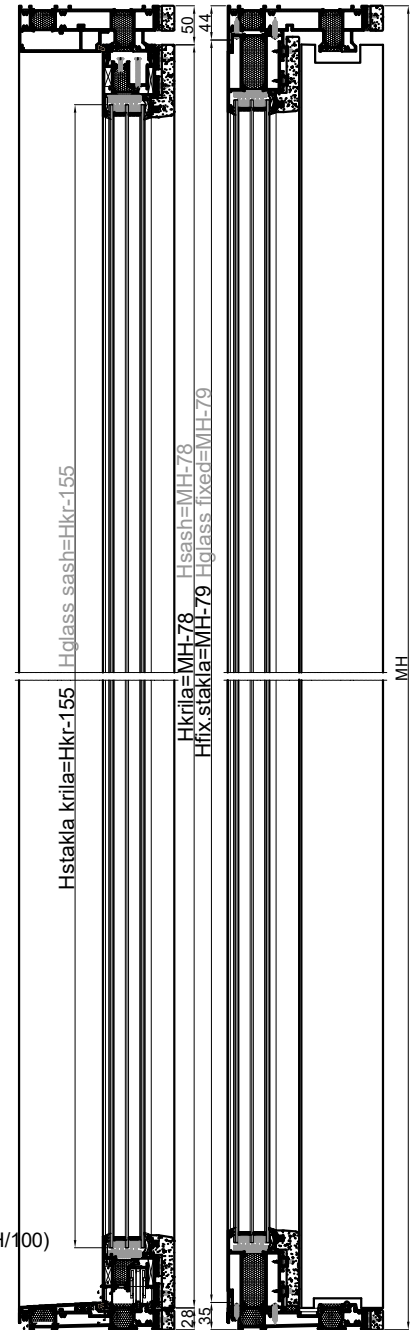
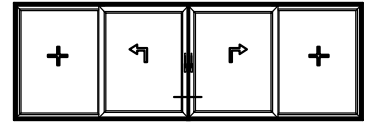

Staklo Glass Mjera Measure

46 mm	Staklo na fiksnom dijelu	Glass on the fixed part	2	(ML/4-52) x (MH-79)
46 mm	Staklo na krilu	Glass on the sash	2	(Lkr-155) x (Hkr-155)

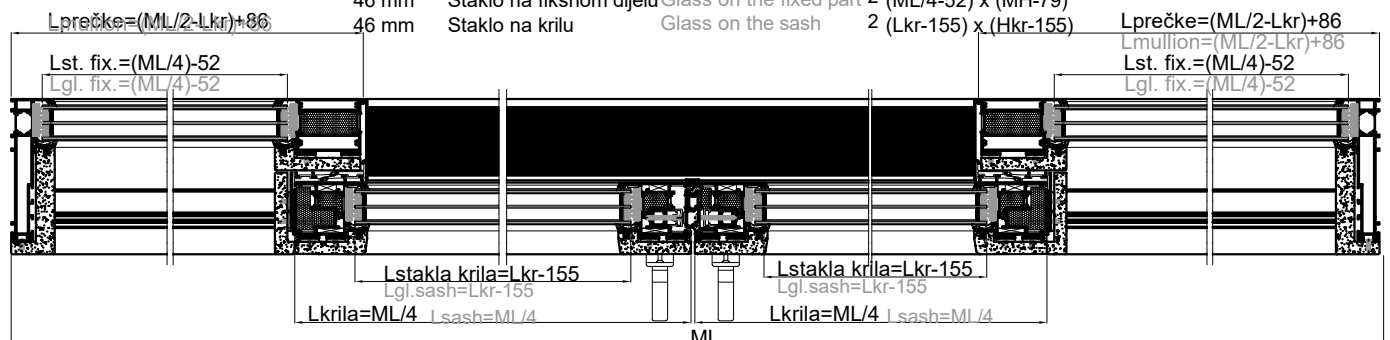

Profili Profiles	Kom Pcs	Mjera Measure	Pilanje Cutting
FT-0431F Okomica rama	2	MH	90-90
FT-0433F Vodoravnica rama - prag	1	Lpr=ML-56	90-90
FT-0432F Vodoravnica rama - gornji dio	1	Lgr=ML-56	90-90
FT-0436F Okomica krila	2	Hkr=MH-78	45-45
FT-0436F Vodoravnica krila	2	Lkr=(ML1/2)-16	45-45
FT-0442F Prečka (bez drvene obloge)	1	Hpr=MH-60	90-90
FT-0445F Prečka	1	Hpr=MH-60	90-90
F-1350 Vodoravna lajsna-krilo	2	Llk=Lkr-187	90-90
F-1350 Okomita lajsna-krilo	2	Hlk=Hkr-187	90-90
F-1350 Vodoravna lajsna-fiksno1	2	Llf=(ML1/2)-100.5	90-90
F-1350 Vodoravna lajsna-fiksno2	2	Llf=ML-ML1-81	90-90
F-1350 Okomita lajsna-fiksno	4	Hlf=MH-111	90-90
F-1415 Lajsna na krilu - uz prečku	1	HI=MH-78	90-90
F-1416 Lajsna na prečki	1	HI=MH-87	90-90
F-1417 Lajsna na pragu	1	LI=(ML1/2)-116.5	90-90
F-1418 Okapnica na pragu	1	Lo=ML-110	90-90
F-1419 Staklo lajsna - fiksni dio1	1	Lfix=ML1/2-98.3	90-90
F-1419 Staklo lajsna - fiksni dio2	1	Lfix=ML-ML1-81	90-90
F-1420 Držač drvene obloge 600.011	2	MH	90-90
F-1421 Lajsna na ramu FT-0432F	1	LI=(ML1/2)-116.5	90-90
F-1428 Umetak ispod brave	1	Hu=MH-180	90-90
F-1112 Al. vodilica	1	Lš=ML1-98	90-90
F-1649 Držač drvene obloge 600.020	1	Lo=ML-ML1-81	90-90
F-1650 Držač drvene obloge 600.021	2	Lo=ML-ML1-81	90-90
Drvene obloge Wooden coverings			
600.018 Okomica uz ram FT-0431F	2	MH-57	90-90
600.011 Vodoravnica uz ram FT-0432F	1	LI=ML	90-90
600.012 Obloga krila uz prečku	1	Ho=MH-78	90-90
600.015 Obloga rama FT-0433F	1	Lo=ML	90-90
600.016 Obloga prečke FT-0442F	1	Ho=MH-62	90-90
600.016 Vod. obloga na fix1. dijelu	2	Lo=ML1/2-100.5	90-90
600.017 Vodoravnica krila	2	Lo=ML1/2-16	45-45
600.017 Okomica krila	2	Ho=MH-78	45-45
600.018 Obloga prečke FT-0445F	1	Ho=MH-58	90-90
600.020 Obloga rama FT-0433F	1	Lo=ML-ML1-81	90-90
600.021 Obloga rama FT-0432F	1	Lo=ML-ML1-81	90-90
Okovi Hardware			
710.193 Kutnik krila	4		
710.401 Pomoćni kutnik krila	4		
730.017 Pomoćni kutnik krila	8		
730.002 Pomoćni kutnik krila	8		
731.010 Pomoćni kutnik krila	4		
Podizno-klizni mehanizam HAUTAU			
Brtve i dodatci Gaskets and accessories			
321.002 Brtva na ramu i krilu		2ML+6MH	
327.003 Brtva u krilu		2Lkr+2Hkr	
344.073 Brtva na prečki		2MH	
344.045 Brtva na ramu i krilu		2ML+6MH	
344.049 Brtva na ramu i krilu		2ML+6MH	
348.061 Brtva na ramu		2ML	
344.062 Brtva na ramu		ML1/2	
344.063 Brtva na ramu i krilu		2ML+4MH	
344.064 Brtva ispod lajsne na pragu		ML1/2	
344.065 Brtva na pragu		ML1	
348.067 Brtva u krilu		ML1	
340.013 Ispuna ispod stakla		2ML+6MH	
345.010 Ublaživač udara	2		
347.011 QL brtva 7mm		2ML1+MH	
347.012 QL brtva 10mm		4MH	
360.009 Monodrain - izvod kapljevina		Lkr/400	
363.077 Set umetaka za lijeva vrata	1		
365.056 PVC umetak-spoj prečke i ra.	1		
371.021 Set umetaka za masku krila	1		
374.083 PVC umetak-spoj prečke i kr.	1	Hkr	90-90
374.083 PVC umetak-spoj prečke i kr.	1	MH-87	90-90
374.063 PVC umetak na pragu	1	ML/3	
375.048 Umetak - kopča		(ML/600)+(4MH/300)	
375.050 Kopča za drvo		(2ML/250)+(MH/250)	
373.078 Usmjerivač krila	4		
344.044 Gumeni umetak ispod krila	2		
347.009 Četkica u gornjem dijelu	1		

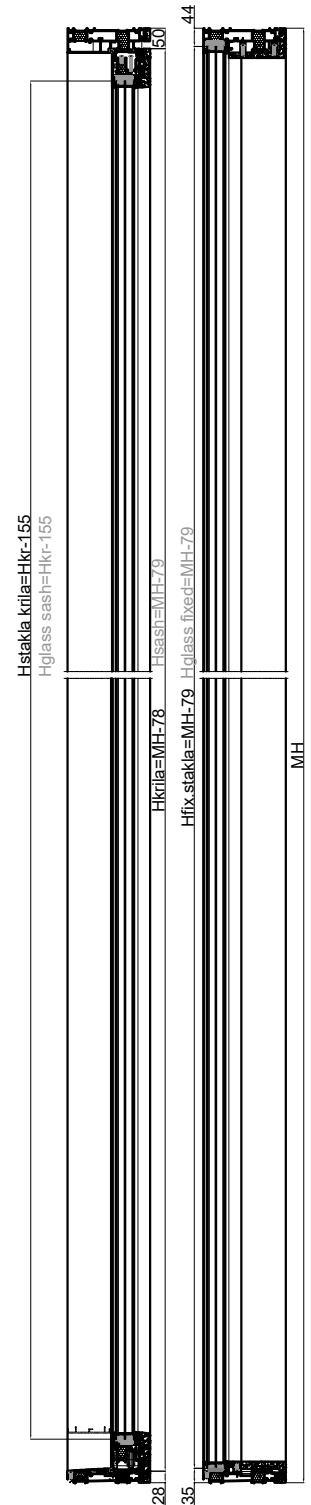
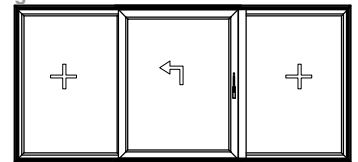

	Mjera Measure
Staklo 46 mm	Staklo na fixnom1 dijelu Glass on the fixed1 part (ML1/2 - 68.5) x (MH-79)
Glass 46 mm	Staklo na fixnom2 dijelu Glass on the fixed2 part (ML-ML1-49) x (MH-79)
Glass 46 mm	Staklo na krilu Glass on the sash (Lkr-155) x (Hkr-155)

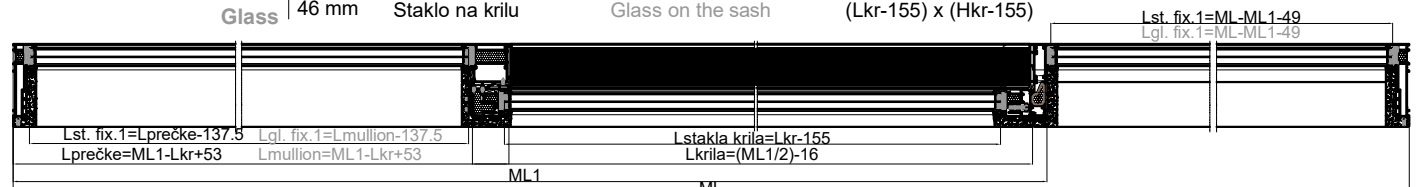

Profili Profiles	Kom Pcs	Mjera Measure	Pilanje Cutting
FT-0431F Okomica rama	2	MH	90-90
FT-0433F Vodoravnica rama - prag	1	Lpr=ML-56	90-90
FT-0432F Vodoravnica rama - gornji dio	1	Lgr=ML-56	90-90
FT-0436F Okomica krila	2	Hkr=MH-78	45-45
FT-0436F Vodoravnica krila	2	Lkr=(ML1/2)-16	45-45
FT-0440F Prečka (sa drv. oblogom)	1	Hpr=MH-60	90-90
FT-0445F Prečka	1	Hpr=MH-60	90-90
F-1350 Vodoravna lajsna-krilo	2	Llk=Lkr-187	90-90
F-1350 Okomita lajsna-krilo	2	Hlk=Hkr-187	90-90
F-1350 Vodoravna lajsna-fiksno1	2	Llf=(ML1/2)-100.5	90-90
F-1350 Vodoravna lajsna-fiksno2	2	Llf=ML-ML1-81	90-90
F-1350 Okomita lajsna-fiksno	4	Hlf=MH-111	90-90
F-1415 Lajsna na krilu - uz prečku	1	HI=MH-78	90-90
F-1416 Lajsna na prečki	1	HI=MH-87	90-90
F-1417 Lajsna na pragu	1	LI=(ML1/2)-116.5	90-90
F-1418 Okapnica na pragu	1	Lo=ML-110	90-90
F-1419 Staklo lajsna - fiksni dio1	1	Lfix=ML1/2-98.3	90-90
F-1419 Staklo lajsna - fiksni dio2	1	Lfix=ML-ML1-81	90-90
F-1420 Držač drvene obloge 600.011	2	MH	90-90
F-1421 Lajsna na ramu FT-0432F	1	LI=(ML1/2)-116.5	90-90
F-1428 Umetak ispod brave	1	Hu=MH-180	90-90
F-1112 Al. vodilica	1	Lš=ML1-98	90-90
F-1649 Držač drvene obloge 600.020	1	Lo=ML-ML1-81	90-90
F-1650 Držač drvene obloge 600.021	2	Lo=ML-ML1-81	90-90
Drvene obloge Wooden coverings			
600.018 Okomica uz ram FT-0431F	2	MH-57	90-90
600.011 Vodoravnica uz ram FT-0432F	1	LI=ML	90-90
600.012 Obloga krila uz prečku	1	Ho=MH-78	90-90
600.015 Obloga rama FT-0433F	1	Lo=ML	90-90
600.013 Obloga prečke FT-0440F	1	Ho=MH-62	90-90
600.016 Vod. obloga na fix1. dijelu	2	Lo=ML1/2-100.5	90-90
600.017 Vodoravnica krila	2	Lo=ML1/2-16	45-45
600.017 Okomica krila	2	Ho=MH-78	45-45
600.018 Obloga prečke FT-0445F	1	Ho=MH-58	90-90
600.020 Obloga rama FT-0433F	1	Lo=ML-ML1-81	90-90
600.021 Obloga rama FT-0432F	1	Lo=ML-ML1-81	90-90
Okovi Hardware			
710.193 Kutnik krila	4		
710.401 Pomoćni kutnik krila	4		
730.017 Pomoćni kutnik krila	8		
730.002 Pomoćni kutnik krila	8		
731.010 Pomoćni kutnik krila	4		
Podizno-klizni mehanizam HAUTAU			
Brtve i dodatci Gaskets and accessories			
321.002 Brtva na ramu i krilu		2ML+6MH	
327.003 Brtva u krilu		2Lkr+2Hkr	
344.073 Brtva na prečki		2MH	
344.045 Brtva na ramu i krilu		2ML+6MH	
344.049 Brtva na ramu i krilu		2ML+6MH	
348.061 Brtva na ramu		2ML	
344.062 Brtva na ramu		ML1/2	
344.063 Brtva na ramu i krilu		2ML+4MH	
344.064 Brtva ispod lajsne na pragu		ML1/2	
344.065 Brtva na pragu		ML1	
348.067 Brtva u krilu		ML1	
340.013 Ispuna ispod stakla		2ML+6MH	
345.010 Ublaživač udara	2		
347.011 QL brtva 7mm		2ML1+MH	
347.012 QL brtva 10mm		4MH	
360.009 Monodrain - izvod kapljevina		Lkr/400	
363.077 Set umetaka za lijeva vrata	1		
365.056 PVC umetak-spoj prečke i ra.	1		
371.021 Set umetaka za masku krila	1		
374.083 PVC umetak-spoj prečke i kr.	1	Hkr	90-90
374.083 PVC umetak-spoj prečke i kr.	1	MH-87	90-90
374.063 PVC umetak na pragu	1	ML/3	
375.048 Umetak - kopča		(ML/600)+(4MH/300)	
375.050 Kopča za drvo		(2ML/250)+(MH/250)	
373.078 Usmjerivač krila	4		
344.044 Gumeni umetak ispod krila	2		
347.009 Četkica u gornjem dijelu	1		

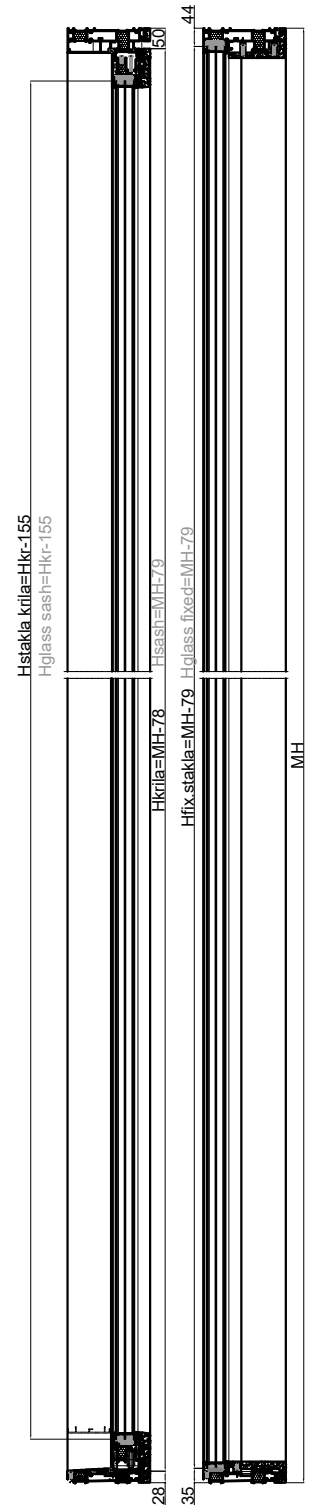
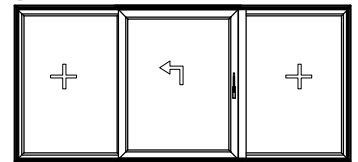

Staklo Glass	46 mm	Staklo na fixnom1 dijelu	Glass on the fixed1 part	(ML1/2 - 68.5) x (MH-79)
	46 mm	Staklo na fixnom2 dijelu	Glass on the fixed2 part	(ML-ML1-49) x (MH-79)
	46 mm	Staklo na krilu	Glass on the sash	(Lkr-155) x (Hkr-155)

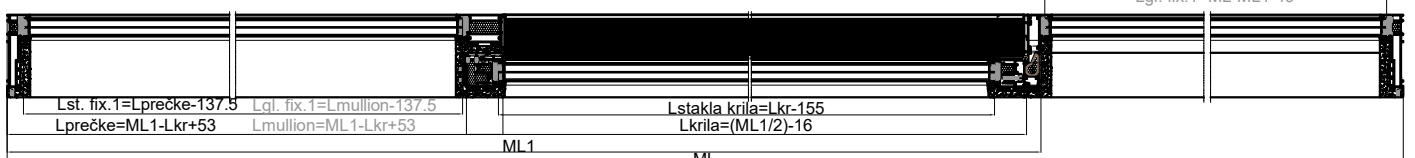

Profili Profiles		Kom Pcs	Mjera Measure	Pilanje Cutting
FT-0431F Okomica rama	Vertical frame profile	2	MH	90-90
FT-0433F Vodoravnica rama - prag	Horizontal frame profile- treshold	1	Lpr=ML-56	90-90
FT-0432F Vodoravnica rama - gornji dio	Horizontal frame profile- topside	1	Lgr=ML-56	90-90
FT-0436F Okomica krila	Vertical sash profile	2	Hkr=MH-78	45-45
FT-0436F Vodoravnica krila	Horizontal sash profile	2	Lkr=(ML1/2)-16	45-45
FT-0442F Prečka (bez drvene obloge)	Mullion (without wooden covering)	1	Hpr=MH-60	90-90
FT-0445F Prečka	Mullion	1	Hpr=MH-60	90-90
F-1350 Vodoravna lajsna-krilo	Horizontal plate - sash	2	Llk=Lkr-187	90-90
F-1350 Okomita lajsna-krilo	Vertical plate - sash	2	HIK=Hkr-187	90-90
F-1350 Vodoravna lajsna-fiksno1	Horizontal plate - fixed1	2	Llf=(ML1/2)-100.5	90-90
F-1350 Vodoravna lajsna-fiksno2	Horizontal plate - fixed2	2	Llf=ML-ML1-81	90-90
F-1350 Okomita lajsna-fiksno	Vertical plate - fixed	4	HIlf=MH-111	90-90
F-1415 Lajsna na krilu - uz prečku	Plate on sash - to the mullion	1	HI=MH-78	90-90
F-1416 Lajsna na prečki	Plate on mullion	1	HI=MH-87	90-90
F-1417 Lajsna na pragu	Plate on treshold	1	LI=(ML1/2)-116.5	90-90
F-1418 Okapnica na pragu	Drip profile on treshold	1	Lo=ML-110	90-90
F-1419 Staklo lajsna - fiksni dio1	Glazing bead - fixed part1	1	Lfix=ML1/2-98.3	90-90
F-1419 Staklo lajsna - fiksni dio2	Glazing bead - fixed part2	1	Lfix=ML-ML1-81	90-90
F-1420 Držać drvene obloge 600.011	Wooden covering holder 600.011	2	MH	90-90
F-1421 Lajsna na ramu FT-0432F	Plate on frame FT-0432F	1	LI=(ML1/2)-116.5	90-90
F-1428 Umetak ispod brave	Insert under the lock	1	Hu=MH-180	90-90
F-1112 Al. vodilica	Al. guide	1	Lš=ML1-98	90-90
F-1649 Držać drvene obloge 600.020	Wooden covering holder 600.020	1	Lo=ML-ML1-81	90-90
Drvene obloge Wooden coverings				
600.018 Okomica uz ram FT-0431F	Vertical cover to the frame FT-0431F	2	MH-57	90-90
600.011 Vodoravnica uz ram FT-0432F	Horizontal cover to the frame FT-0432F	1	LI=ML	90-90
600.012 Obloga krila uz prečku	Sash coverings to the mullion	1	Ho=MH-78	90-90
600.015 Obloga rama FT-0433F	Frame coverings FT-0433F	1	Lo=ML	90-90
600.016 Obloga prečke FT-0442F	Mullion coverings FT-0442F	1	Ho=MH-62	90-90
600.016 Vod. obloga na fix1. dijelu	Horizontal coverings on fix1. section	2	Lo=ML1/2-100.5	90-90
600.017 Vodoravnica krila	Horizontal sash profile	2	Lo=ML1/2-16	45-45
600.017 Okomica krila	Vertical frame profile	2	Ho=MH-78	45-45
600.018 Obloga prečke FT-0445F	Mullion coverings FT-0445F	1	Ho=MH-58	90-90
600.020 Obloga rama FT-0433F	Frame coverings FT-0433F	1	Lo=ML-ML1-81	90-90
600.016 Obloga rama FT-0432F	Frame coverings FT-0432F	1	Lo=ML-ML1-81	90-90
Okovi Hardware				
710.193 Kutnik krila	Sash corner bracket	4		
710.401 Pomoćni kutnik krila	Support frame corner bracket	4		
730.017 Pomoćni kutnik krila	Support frame corner bracket	8		
730.002 Pomoćni kutnik krila	Support frame corner bracket	8		
731.010 Pomoćni kutnik krila	Support frame corner bracket	4		
Podizno-klizni mehanizam HAUTAU Lift and slide mechanism HAUTAU				
Brtve i dodatci Gaskets and accessories				
321.002 Brtva na ramu i krilu	Gasket on frame and sash		2ML+6MH	
327.003 Brtva u krilu	Gasket in sash		2Lkr+2Hkr	
344.073 Brtva na prečki	Gasket on mullion		2MH	
344.045 Brtva na ramu i krilu	Gasket on frame and sash		2ML+6MH	
344.049 Brtva na ramu i krilu	Gasket on frame and sash		2ML+6MH	
348.061 Brtva na ramu	Gasket on frame		2ML	
344.062 Brtva na ramu	Gasket on frame		ML1/2	
344.063 Brtva na ramu i krilu	Gasket on frame and sash		2ML+4MH	
344.064 Brtva ispod lajsne na pragu	Gasket under the plate on treshold		ML1/2	
344.065 Brtva na pragu	Gasket on treshold		ML1	
348.067 Brtva u krilu	Gasket in sash		ML1	
340.013 Ispuna ispod stakla	Filling under the glass		2ML+6MH	
345.010 Ublaživač udara	Bump absorber	2		
347.011 QL brtva 7mm	QL gasket 7mm		2ML1+MH	
347.012 QL brtva 10mm	QL gasket 10mm		4MH	
360.009 Monodrain - izvod kapljevina	Monodrain - liquid excerpt		Lkr/400	
363.077 Set umetaka za lijeva vrata	Set of inserts for left door	1		
365.056 PVC umetak-spoj prečke i ra.	PVC insert-contact of mullion and frame	1		
371.021 Set umetaka za masku krila	Set of inserts for mullion mask	1		
374.083 PVC umetak-spoj prečke i kr.	PVC insert-contact of mullion and sash	1	Hkr	90-90
374.083 PVC umetak-spoj prečke i kr.	PVC insert-contact of mullion and sash	1	MH-87	90-90
374.063 PVC umetak na pragu	PVC insert on treshold	1	ML/3	
375.048 Umetak - kopča	Insert - Clamp		(ML/600)+(4MH/300)	
375.050 Kopča za drvo	Clamp for wood		(2ML/250)+(MH/250)	
373.078 Usmjerivač krila	Sash router	4		
344.044 Gumeni umetak ispod krila	Rubber insert	2		
347.009 Četkica u gornjem dijelu	Brush insert	1		
Staklo Glass				
46 mm Staklo na fixnom1 dijelu	Glass on the fixed1 part		(ML1/2 - 68.5) x (MH-79)	
46 mm Staklo na fixnom2 dijelu	Glass on the fixed2 part		(ML-ML1-49) x (MH-79)	
46 mm Staklo na krilu	Glass on the sash		(Lkr-155) x (Hkr-155)	

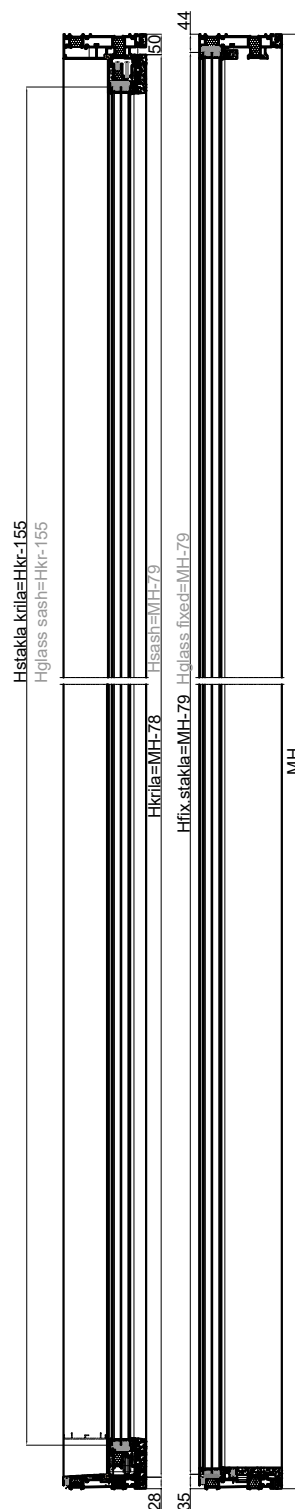
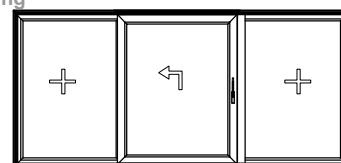

Profili Profiles		Kom Pcs	Mjera Measure	Pilanje Cutting
FT-0431F Okomica rama	Vertical frame profile	2	MH	90-90
FT-0433F Vodoravnica rama - prag	Horizontal frame profile- treshold	1	Lpr=ML-56	90-90
FT-0432F Vodoravnica rama - gornji dio	Horizontal frame profile- topside	1	Lgr=ML-56	90-90
FT-0436F Okomica krila	Vertical sash profile	2	Hkr=MH-78	45-45
FT-0436F Vodoravnica krila	Horizontal sash profile	2	Lkr=(ML/2)-16	45-45
FT-0440F Prečka (sa drv. oblogom)	Mullion (with wooden covering)	1	Hpr=MH-60	90-90
FT-0445F Prečka	Mullion	1	Hpr=MH-60	90-90
F-1350 Vodoravna lajsna-krilo	Horizontal plate - sash	2	Llk=Lkr-187	90-90
F-1350 Okomita lajsna-krilo	Vertical plate - sash	2	Hlk=Hkr-187	90-90
F-1350 Vodoravna lajsna-fiksno1	Horizontal plate - fixed1	2	Llf=(ML/2)-100.5	90-90
F-1350 Vodoravna lajsna-fiksno2	Horizontal plate - fixed2	2	Llf=ML-ML1-81	90-90
F-1350 Okomita lajsna-fiksno	Vertical plate - fixed	4	Hlf=MH-111	90-90
F-1415 Lajsna na krilu - uz prečku	Plate on sash - to the mullion	1	HI=MH-78	90-90
F-1416 Lajsna na prečki	Plate on mullion	1	HI=MH-87	90-90
F-1417 Lajsna na pragu	Plate on treshold	1	LI=(ML/2)-116.5	90-90
F-1418 Okapnica na pragu	Drip profile on treshold	1	Lo=ML-110	90-90
F-1419 Staklo lajsna - fiksni dio1	Glazing bead - fixed part1	1	Lfix=ML/2-98.3	90-90
F-1419 Staklo lajsna - fiksni dio2	Glazing bead - fixed part2	1	Lfix=ML-ML1-81	90-90
F-1420 Držać drvene obloge 600.011	Wooden covering holder 600.011	2	MH	90-90
F-1421 Lajsna na ramu FT-0432F	Plate on frame FT-0432F	1	LI=(ML/2)-116.5	90-90
F-1428 Umetak ispod brave	Insert under the lock	1	Hu=MH-180	90-90
F-1112 Al. vodilica	Al. guide	1	Lš=ML1-98	90-90
F-1649 Držać drvene obloge 600.020	Wooden covering holder 600.020	1	Lo=ML-ML1-81	90-90
Drvene obloge Wooden coverings				
600.018 Okomica uz ram FT-0431F	Vertical cover to the frame FT-0431F	2	MH-57	90-90
600.011 Vodoravnica uz ram FT-0432F	Horizontal cover to the frame FT-0432F	1	LI=ML	90-90
600.012 Obloga krila uz prečku	Sash coverings to the mullion	1	Ho=MH-78	90-90
600.015 Obloga rama FT-0433F	Frame coverings FT-0433F	1	Lo=ML	90-90
600.013 Obloga prečke FT-0440F	Mullion coverings FT-0440F	1	Ho=MH-62	90-90
600.016 Vod. obloga na fix1. dijelu	Horizontal coverings on fix1. section	2	Lo=ML/2-100.5	90-90
600.017 Vodoravnica krila	Horizontal sash profile	2	Lo=ML/2-16	45-45
600.017 Okomica krila	Vertical frame profile	2	Ho=MH-78	45-45
600.018 Obloga prečke FT-0445F	Mullion coverings FT-0445F	1	Ho=MH-58	90-90
600.020 Obloga rama FT-0433F	Frame coverings FT-0433F	1	Lo=ML-ML1-81	90-90
600.016 Obloga rama FT-0432F	Frame coverings FT-0432F	1	Lo=ML-ML1-81	90-90
Okovi Hardware				
710.193 Kutnik krila	Sash corner bracket	4		
710.401 Pomoćni kutnik krila	Support frame corner bracket	4		
730.017 Pomoćni kutnik krila	Support frame corner bracket	8		
730.002 Pomoćni kutnik krila	Support frame corner bracket	8		
731.010 Pomoćni kutnik krila	Support frame corner bracket	4		
Podizno-klizni mehanizam HAUTAU Lift and slide mechanism HAUTAU				
Brtve i dodatci Gaskets and accessories				
321.002 Brtva na ramu i krilu	Gasket on frame and sash		2ML+6MH	
327.003 Brtva u krilu	Gasket in sash		2Lkr+2Hkr	
344.073 Brtva na prečki	Gasket on mullion		2MH	
344.045 Brtva na ramu i krilu	Gasket on frame and sash		2ML+6MH	
344.049 Brtva na ramu i krilu	Gasket on frame and sash		2ML+6MH	
348.061 Brtva na ramu	Gasket on frame		2ML	
344.062 Brtva na ramu	Gasket on frame		ML/2	
344.063 Brtva na ramu i krilu	Gasket on frame and sash		2ML+4MH	
344.064 Brtva ispod lajsne na pragu	Gasket under the plate on treshold		ML/2	
344.065 Brtva na pragu	Gasket on treshold		ML1	
348.067 Brtva u krilu	Gasket in sash		ML1	
340.013 Ispuna ispod stakla	Filling under the glass		2ML+6MH	
345.010 Ublaživač udara	Bump absorber	2		
347.011 QL brtva 7mm	QL gasket 7mm		2ML1+MH	
347.012 QL brtva 10mm	QL gasket 10mm		4MH	
360.009 Monodrain - izvod kapljevina	Monodrain - liquid excerpt		Lkr/400	
363.077 Set umetaka za lijeva vrata	Set of inserts for left door	1		
365.056 PVC umetak-spoj prečke i ra.	PVC insert-contact of mullion and frame	1		
371.021 Set umetaka za masku krila	Set of inserts for mullion mask	1		
374.083 PVC umetak-spoj prečke i kr.	PVC insert-contact of mullion and sash	1	Hkr	90-90
374.083 PVC umetak-spoj prečke i kr.	PVC insert-contact of mullion and sash	1	MH-87	90-90
374.063 PVC umetak na pragu	PVC insert on treshold	1	ML/3	
375.048 Umetak - kopča	Insert - Clamp		(ML/600)+(4MH/300)	
375.050 Kopča za drvo	Clamp for wood		(2ML/250)+(MH/250)	
373.078 Usmjerivač krila	Sash router	4		
344.044 Gumeni umetak ispod krila	Rubber insert	2		
347.009 Četkica u gornjem dijelu	Brush insert	1		
Staklo Glass				
46 mm	Staklo na fixnom1 dijelu	Glass on the fixed1 part	(ML/2 - 68.5) x (MH-79)	
46 mm	Staklo na fixnom2 dijelu	Glass on the fixed2 part	(ML-ML1-49) x (MH-79)	
46 mm	Staklo na krilu	Glass on the sash	(Lkr-155) x (Hkr-155)	

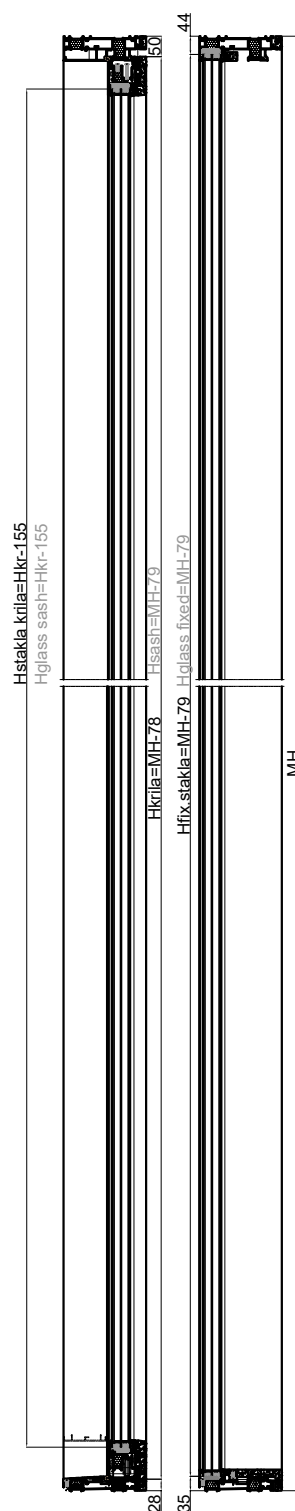
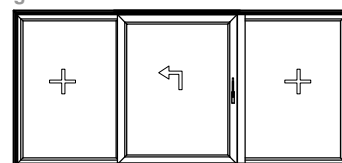

Profili Profiles		Kom Pcs	Mjera Measure	Pilanje Cutting
FT-0431F Okomica rama	Vertical frame profile	2	MH	90-90
FT-0433F Vodoravnica rama - prag	Horizontal frame profile- treshold	1	Lpr=ML-56	90-90
FT-0432F Vodoravnica rama - gornji dio	Horizontal frame profile- topside	1	Lgr=ML-56	90-90
FT-0436F Okomica krila	Vertical sash profile	2	Hkr=MH-78	45-45
FT-0436F Vodoravnica krila	Horizontal sash profile	2	Lkr=(ML1/2)-16	45-45
FT-0442F Prečka (bez drvene obloge)	Mullion (without wooden covering)	1	Hpr=MH-60	90-90
FT-0445F Prečka	Mullion	1	Hpr=MH-60	90-90
FT-0446F Profil umetka za fiksni dio 1	Insert profile - fixed 1	2	Lum=(ML1/2)-98.5	90-90
FT-0446F Profil umetka za fiksni dio 2	Insert profile - fixed 2	2	Lum=ML-ML1-79	90-90
F-1350 Vodoravna lajsna-krilo	Horizontal plate - sash	2	Llk=Lkr-187	90-90
F-1350 Okomita lajsna-krilo	Vertical plate - sash	2	Hlk=Hkr-187	90-90
F-1350 Vodoravna lajsna-fiksno1	Horizontal plate - fixed1	2	Llf=(ML1/2)-100.5	90-90
F-1350 Vodoravna lajsna-fiksno2	Horizontal plate - fixed2	2	Llf=ML-ML1-81	90-90
F-1350 Okomita lajsna-fiksno	Vertical plate - fixed	4	Hlf=MH-217.5	90-90
F-1415 Lajsna na krilu - uz prečku	Plate on sash - to the mullion	1	HI=MH-78	90-90
F-1416 Lajsna na prečki	Plate on mullion	1	HI=MH-87	90-90
F-1417 Lajsna na pragu	Plate on treshold	1	LI=(ML1/2)-116.5	90-90
F-1418 Okapnica na pragu	Drip profile on treshold	1	Lo=ML-110	90-90
F-1419 Staklo lajsna - fiksni dio1	Glazing bead - fixed part1	1	Lfix=ML1/2-98.3	90-90
F-1419 Staklo lajsna - fiksni dio2	Glazing bead - fixed part2	1	Lfix=ML-ML1-81	90-90
F-1420 Držač drvene obloge 600.011	Wooden covering holder 600.011	2	MH	90-90
F-1421 Lajsna na ramu FT-0432F	Plate on frame FT-0432F	1	LI=(ML1/2)-116.5	90-90
F-1428 Umetak ispod brave	Insert under the lock	1	Hu=MH-180	90-90
F-1112 Al. vodilica	Al. guide	1	Lš=ML1-98	90-90
F-1649 Držač drvene obloge 600.030	Wooden covering holder 600.030	4	Lo=(ML1/2)-100.5	90-90
F-1649 Držač drvene obloge 600.030	Wooden covering holder 600.030	4	Lo=ML-ML1-81	90-90
Drvene obloge Wooden coverings				
600.018 Okomica uz ram FT-0431F	Vertical cover to the frame FT-0431F	2	MH-57	90-90
600.011 Vodoravnica uz ram FT-0432F	Horizontal cover to the frame FT-0432F	1	LI=ML	90-90
600.012 Obloga krila uz prečku	Sash coverings to the mullion	1	Ho=MH-78	90-90
600.015 Obloga rama FT-0433F	Frame coverings FT-0433F	1	Lo=ML	90-90
600.016 Obloga prečke FT-0442F	Mullion coverings FT-0442F	1	Ho=MH-62	90-90
600.030 Vod. obloga na fix1.dijelu	Horizontal coverings on fix1. section	2	Lo=ML1/2-100.5	90-90
600.017 Vodoravnica krila	Horizontal sash profile	2	Lo=ML1/2-16	45-45
600.017 Okomica krila	Vertical frame profile	2	Ho=MH-78	45-45
600.018 Obloga prečke FT-0445F	Mullion coverings FT-0445F	1	Ho=MH-58	90-90
600.030 Vod. obloga na fix2.dijelu	Horizontal coverings on fix2. section	2	Lo=ML-ML1-81	90-90
Okovi Hardware				
710.193 Kutnik krila	Sash corner bracket	4		
710.401 Pomoćni kutnik krila	Support frame corner bracket	4		
730.017 Pomoćni kutnik krila	Support frame corner bracket	8		
730.002 Pomoćni kutnik krila	Support frame corner bracket	8		
731.010 Pomoćni kutnik krila	Support frame corner bracket	4		
Podizno-klizni mehanizam HAUTAU	Lift and slide mechanism HAUTAU			
Brtve i dodatci Gaskets and accessories				
321.002 Brtva na ramu i krilu	Gasket on frame and sash		2ML+6MH	
327.003 Brtva u krilu	Gasket in sash		2Lkr+2Hkr	
344.073 Brtva na prečki	Gasket on mullion		2MH	
344.045 Brtva na ramu i krilu	Gasket on frame and sash		2ML+6MH	
344.049 Brtva na ramu i krilu	Gasket on frame and sash		2ML+6MH	
348.061 Brtva na ramu	Gasket on frame		2ML	
344.062 Brtva na ramu	Gasket on frame		ML1/2	
344.063 Brtva na ramu i krilu	Gasket on frame and sash		2ML+4MH	
344.064 Brtva ispod lajsne na pragu	Gasket under the plate on treshold		ML1/2	
344.065 Brtva na pragu	Gasket on treshold		ML1	
348.067 Brtva u krilu	Gasket in sash		ML1	
340.013 Ispuna ispod stakla	Filling under the glass		2ML+6MH	
345.010 Ublaživač udara	Bump absorber	2		
347.011 QL brtva 7mm	QL gasket 7mm		2ML1+MH	
347.012 QL brtva 10mm	QL gasket 10mm		4MH	
360.009 Monodrain - izvod kapljevina	Monodrain - liquid excerpt		Lkr/400	
363.077 Set umetaka za lijeva vrata	Set of inserts for left door	1		
365.056 PVC umetak-spoj prečke i ra.	PVC insert-contact of mullion and frame	1		
371.021 Set umetaka za masku krila	Set of inserts for mullion mask	1		
374.083 PVC umetak-spoj prečke i kr.	PVC insert-contact of mullion and sash	1	Hkr	90-90
374.083 PVC umetak-spoj prečke i kr.	PVC insert-contact of mullion and sash	1	MH-87	90-90
374.063 PVC umetak na pragu	PVC insert on treshold	1	ML/3	
375.048 Umetak - kopča	Insert - Clamp		(ML/600)+(4MH/300)	
375.050 Kopča za drvo	Clamp for wood		(2ML/250)+(MH/250)	
373.078 Usmjerivač krila	Sash router	4		
344.044 Gumeni umetak ispod krila	Rubber insert	2		
347.009 Četkica u gornjem dijelu	Brush insert	1		

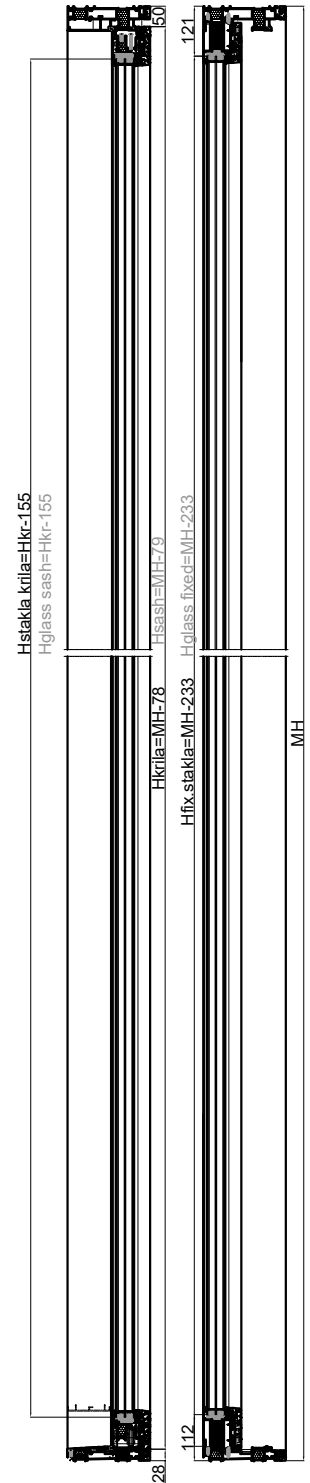
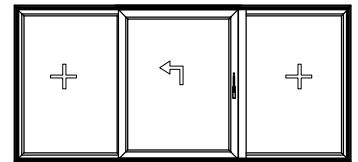

Staklo Glass	Thickness	Location	Formula	Measure
	46 mm	Staklo na fixnom1 dijelu	Glass on the fixed1 part	(ML1/2 - 68.5) x (MH-233)
	46 mm	Staklo na fixnom2 dijelu	Glass on the fixed2 part	(ML-ML1-49) x (MH-233)
	46 mm	Staklo na krilu	Glass on the sash	(Lkr-155) x (Hkr-155)



Profili Profiles **Kom Pcs** **Mjera Measure** **Pilanje Cutting**

FT-0431F	Okomica rama	Vertical frame profile	2	MH	90-90
FT-0433F	Vodoravnica rama - prag	Horizontal frame profile- threshold	1	Lpr=ML-56	90-90
FT-0432F	Vodoravnica rama - gornji dio	Horizontal frame profile- topside	1	Lgr=ML-56	90-90
FT-0436F	Okomica krila	Vertical sash profile	2	Hkr=MH-78	45-45
FT-0436F	Vodoravnica krila	Horizontal sash profile	2	Lkr=(ML1/2)-16	45-45
FT-0440F	Prečka (sa drv. oblogom)	Mullion (with wooden covering)	1	Hpr=MH-60	90-90
FT-0445F	Prečka	Mullion	1	Hpr=MH-60	90-90
FT-0446F	Profil umetka za fiksni dio 1	Insert profile - fixed 1	2	Lum=(ML1/2)-98.5	90-90
FT-0446F	Profil umetka za fiksni dio 2	Insert profile - fixed 2	2	Lum=ML-ML1-79	90-90
F-1350	Vodoravna lajsna-krilo	Vertical plate - sash	2	Llk=Lkr-187	90-90
F-1350	Okomita lajsna-krilo	Vertical plate - sash	2	Hlk=Hkr-187	90-90
F-1350	Vodoravna lajsna-fiksno1	Horizontal plate - fixed1	2	Llf=(ML1/2)-100.5	90-90
F-1350	Vodoravna lajsna-fiksno2	Horizontal plate - fixed2	2	Llf=ML-ML1-81	90-90
F-1350	Okomita lajsna-fiksno	Vertical plate - fixed	4	Hlf=MH-217.5	90-90
F-1415	Lajsna na krilu - uz prečku	Plate on sash - to the mullion	1	HI=MH-78	90-90
F-1416	Lajsna na prečki	Plate on mullion	1	HI=MH-87	90-90
F-1417	Lajsna na pragu	Plate on threshold	1	LI=(ML1/2)-116.5	90-90
F-1418	Okapnica na pragu	Drip profile on threshold	1	Lo=ML-110	90-90
F-1419	Staklo lajsna - fiksni dio1	Glazing bead - fixed part1	1	Lfix=ML1/2-98.3	90-90
F-1419	Staklo lajsna - fiksni dio2	Glazing bead - fixed part2	1	Lfix=ML-ML1-81	90-90
F-1420	Držać drvene obloge 600.011	Wooden covering holder 600.011	2	MH	90-90
F-1421	Lajsna na ramu FT-0432F	Plate on frame FT-0432F	1	LI=(ML1/2)-116.5	90-90
F-1428	Umetak ispod brave	Insert under the lock	1	Hu=MH-180	90-90
F-1112	Al. vodilica	Al. guide	1	Lš=ML1-98	90-90
F-1649	Držać drvene obloge 600.030	Wooden covering holder 600.030	1	Lo=(ML1/2)-100.5	90-90
F-1649	Držać drvene obloge 600.030	Wooden covering holder 600.030	2	Lo=ML-ML1-81	90-90

Drvene obloge Wooden coverings

600.018	Okomica uz ram FT-0431F	Vertical cover to the frame FT-0431F	2	MH-57	90-90
600.011	Vodoravnica uz ram FT-0432F	Horizontal cover to the frame FT-0432F	1	LI=ML	90-90
600.012	Obloga krila uz prečku	Sash coverings to the mullion	1	Ho=MH-78	90-90
600.015	Obloga rama FT-0433F	Frame coverings FT-0433F	1	Lo=ML	90-90
600.013	Obloga prečke FT-0440F	Mullion coverings FT-0440F	1	Ho=MH-62	90-90
600.016	Vod. obloga na fix1. dijelu	Horizontal coverings on fix1. section	2	Lo=ML1/2-100.5	90-90
600.017	Vodoravnica krila	Horizontal sash profile	2	Lo=ML1/2-16	45-45
600.017	Okomica krila	Vertical frame profile	2	Ho=MH-78	45-45
600.018	Obloga prečke FT-0445F	Mullion coverings FT-0445F	1	Ho=MH-58	90-90
600.020	Obloga rama FT-0433F	Frame coverings FT-0433F	1	Lo=ML-ML1-81	90-90
600.021	Obloga rama FT-0432F	Frame coverings FT-0432F	1	Lo=ML-ML1-81	90-90

Okovi Hardware

710.193	Kutnik krila	Sash corner bracket	4		
710.401	Pomoćni kutnik krila	Support frame corner bracket	4		
730.017	Pomoćni kutnik krila	Support frame corner bracket	8		
730.002	Pomoćni kutnik krila	Support frame corner bracket	8		
731.010	Pomoćni kutnik krila	Support frame corner bracket	4		
	Podizno-klizni mehanizam HAUTAU	Lift and slide mechanism HAUTAU			

Brtve i dodatci Gaskets and accessories

321.002	Brtva na ramu i krilu	Gasket on frame and sash		2ML+6MH	
327.003	Brtva u krilu	Gasket in sash		2Lkr+2Hkr	
344.073	Brtva na prečki	Gasket on mullion		2MH	
344.045	Brtva na ramu i krilu	Gasket on frame and sash		2ML+6MH	
344.049	Brtva na ramu i krilu	Gasket on frame and sash		2ML+6MH	
348.061	Brtva na ramu	Gasket on frame		2ML	
344.062	Brtva na ramu	Gasket on frame		ML1/2	
344.063	Brtva na ramu i krilu	Gasket on frame and sash		2ML+4MH	
344.064	Brtva ispod lajsne na pragu	Gasket under the plate on threshold		ML1/2	
344.065	Brtva na pragu	Gasket on threshold		ML1	
348.067	Brtva u krilu	Gasket in sash		ML1	
340.013	Ispuna ispod stakla	Filling under the glass		2ML+6MH	
345.010	Ublaživač udara	Bump absorber	2		
347.011	QL brtva 7mm	QL gasket 7mm		2ML1+MH	
347.012	QL brtva 10mm	QL gasket 10mm		4MH	
360.009	Monodrain - izvod kapljevina	Monodrain - liquid excerpt		Lkr/400	
363.077	Set umetaka za lijeva vrata	Set of inserts for left door	1		
365.056	PVC umetak-spoj prečke i ra.	PVC insert-contact of mullion and frame	1		
371.021	Set umetaka za masku krila	Set of inserts for mullion mask	1		
374.083	PVC umetak-spoj prečke i kr.	PVC insert-contact of mullion and sash	1	Hkr	90-90
374.083	PVC umetak-spoj prečke i kr.	PVC insert-contact of mullion and sash	1	MH-87	90-90
374.063	PVC umetak na pragu	PVC insert on threshold	1	ML/3	
375.048	Umetak - kopča	Insert - Clamp		(ML/600)+(4MH/300)	
375.050	Kopča za drvo	Clamp for wood		(2ML/250)+(MH/250)	
373.078	Usmjerivač krila	Sash router	4		
344.044	Gumeni umetak ispod krila	Rubber insert	2		
347.009	Četkica u gornjem dijelu	Brush insert	1		

Mjera Measure

Staklo Glass	46 mm	Staklo na fixnom1 dijelu	Glass on the fixed1 part	(ML1/2 - 68.5) x (MH-79)
	46 mm	Staklo na fixnom2 dijelu	Glass on the fixed2 part	(ML-ML1-49) x (MH-79)
	46 mm	Staklo na krilu	Glass on the sash	(Lkr-155) x (Hkr-155)

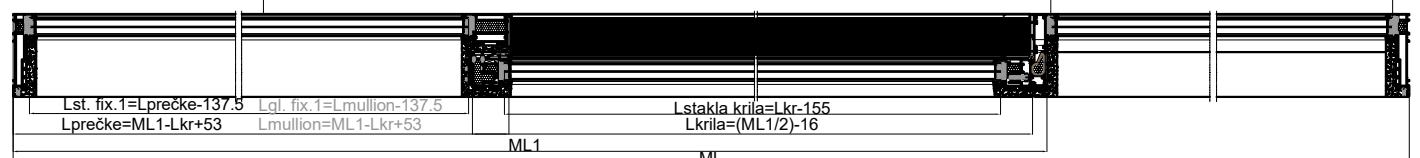
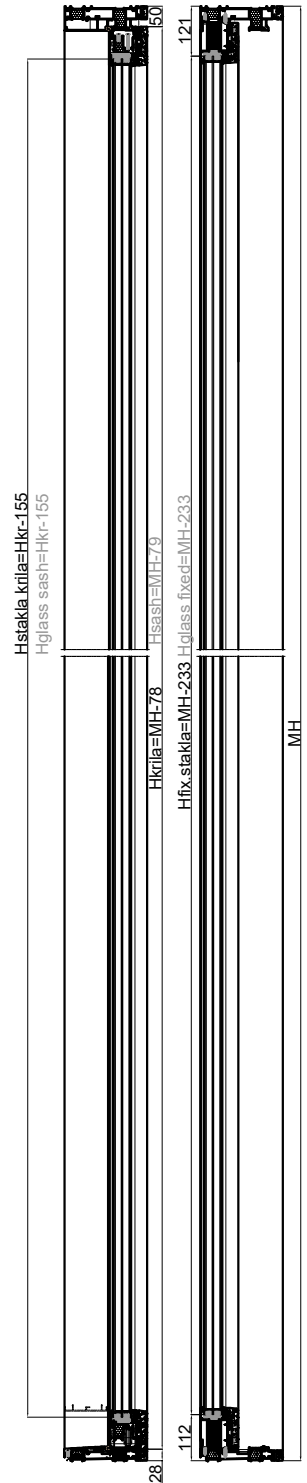
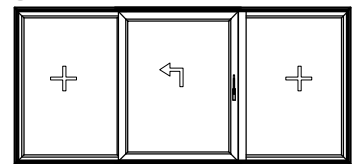

FEAL



Skenirajte QR kod i registrirajte se na partner.feal.ba

Scan the QR code and register on partner.feal.ba

TERMO 200 DA

Knjiga A / *Book A*

Rujan 2021. / *September 2021*

FEAL d.o.o.
Trnska cesta 146
88220 Široki Brijeg
Bosna i Hercegovina
Tel. +387 39 704-269; 705-807; 705-636
Fax. +387 39 704-358
info@feal.ba
www.feal.ba