

# FEAL

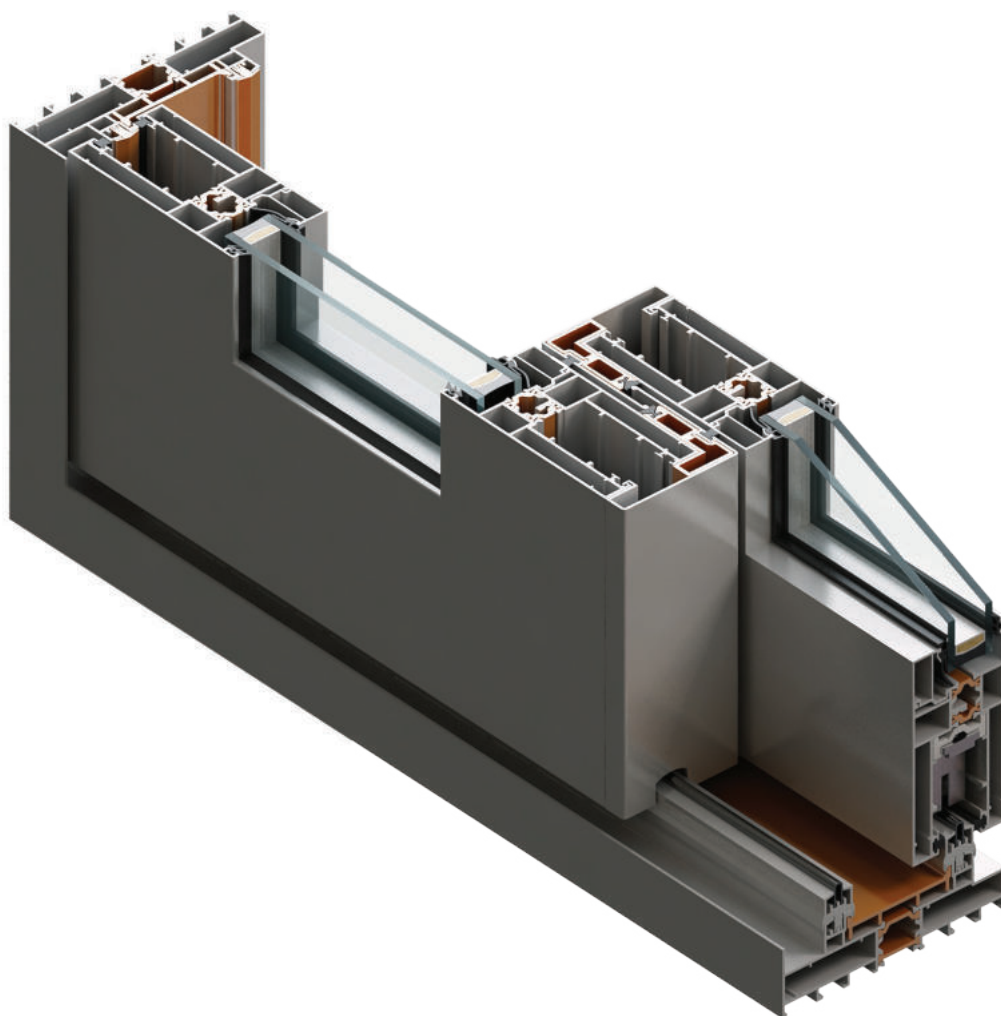

## TERMO 120

PODIZNO-KLIZNA VRATA  
*LIFT & SLIDE DOORS*

Knjiga B / *Book B*



## SADRŽAJ



06	VEZNI ELEMENTI	403.06.000-005
07	PVC ELEMENTI	403.07.000-007
08	MEHANIZMI	403.08.000-009
09	BRTVILA	403.09.000-007
10	DODACI	403.10.000-003
11	OBRADA I MONTAŽA	403.11.000-105
12	REZNE LISTE	403.12.000-019



# Vezni elementi

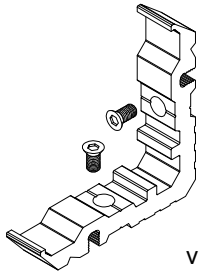
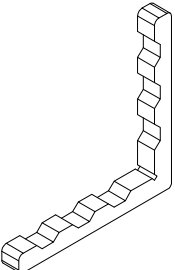
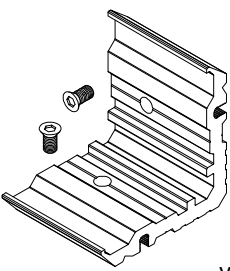
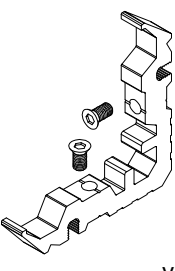
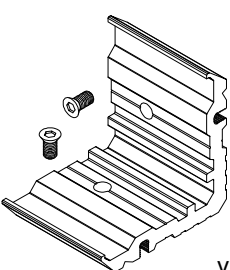
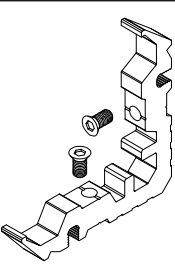

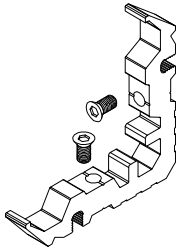
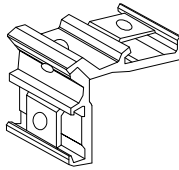
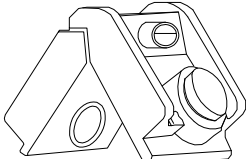
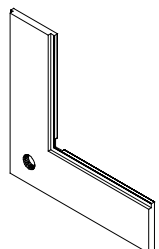
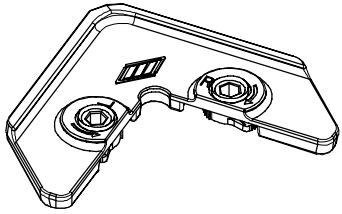
Oznaka	Izgled-presjek	Opis	Materijal	Nap.
710.445	 <p>l=17.5mm vijci 431.266</p>	- Kutna spojnica za komoru 18x13	Al.	
710.011	 <p>l=7.5 mm</p>	- Kutna spojnica za komoru 7.9x8 - Stara oznaka K 120-3	Al.	
710.446	 <p>l=63mm vijci 431.266</p>	- Kutna spojnica za komoru 63.55x13	Al.	
710.504	 <p>l=10.8 mm vijci 431.293</p>	- Kutna spojnica za komoru 11.3X17 (krilo TI 917/ 918 i TI 917/918-A)	Al.	
710.478	 <p>l=69.8mm vijci 431.266</p>	- Kutna spojnica za komoru 70.3x13	Al.	
710.519	 <p>l=10.6 mm vijci 431.293</p>	- Kutna spojnica za komoru 11.1x16.5	Al.	

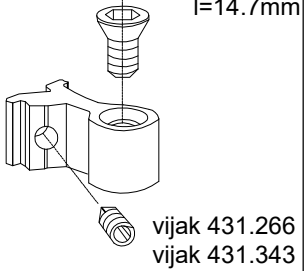
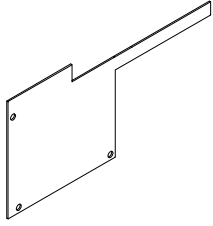
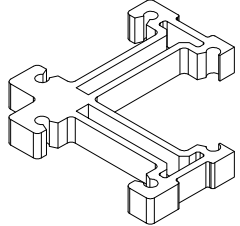
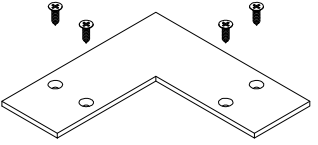
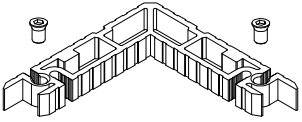
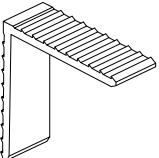

Oznaka	Izgled-presjek	Opis	Materijal	Nap.
710.520	 <p>l=10.6 mm</p> <p>vijci 431.293</p>	- Kutna spojnica za komoru 11.1x16.5	Al.	
730.013		- Kutna spojnica za komoru 41.65x11.2 - Stara oznaka 0432	-	
730.008		- Kutna spojnica za komoru 29x15.2 - Stara oznaka 1001	-	
730.017		- Pomoćni kutnik za komoru 19.2x1.6	Zamak	
731.010		- Kutna spojnica za usku komoru - Stara oznaka 2019/500	Zamak #3	
730.001		- Kutna spojnica za komoru 2x4.8 - Stara oznaka G-112	Inox	

Oznaka	Izgled-presjek	Opis	Materijal	Nap.
710.066	 <p>l=14.7mm</p> <p>vijak 431.266 vijak 431.343</p>	<ul style="list-style-type: none"> <li>- Veznik prečke</li> <li>- Stara oznaka E-200</li> </ul>	Al.	
521.189		- Bočni čep za kadicu (F-1479; F-1480; F-1478)	Al.	
710.407		- Spojnica ramova (dvije; tri staze) pod 90°	Al.	
710.428	 <p>vijci 431.129</p>	- Spojnica ramova TI 931/692	Al.	
710.429	 <p>l=14.6 mm</p> <p>vijci 431.266</p>	- Spojnica ramova TI 931/692	Al.	
710.430		- Spojnica ramova TI 931/692	Al.	



# Pvc elementi

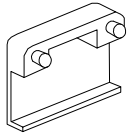
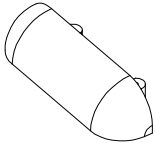
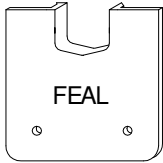
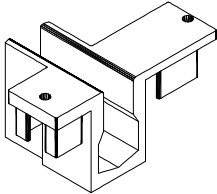
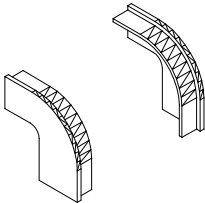

Oznaka	Izgled-presjek	Opis	Materijal	Nap.
373.003.01 02 03		- Maska za drenažni otvor - Stara oznaka 2328	PVC	
370.070.01 03		- Maska sa klapnom za drenažni otvor - Boje: 01- bijela; 03- crna	PVC	
375.016.01 02 03		- Čep maske krila - Stara oznaka DI-261	PVC	
375.017		- Čep profila FT-0706 - Stara oznaka DI-265	PVC	
375.018.01 02 03		- Čep profila F-1231; par - Stara oznaka DI-269	PVC	
375.019.01 02 03		- Umetak za klučanje termo 120 klizno (Notter) - Stara oznaka OK-120-U3	PVC	

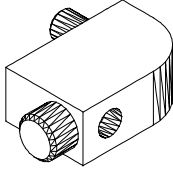
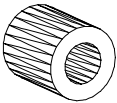
Oznaka	Izgled-presjek	Opis	Materijal	Nap.
375.020		- Odbojnik na krilu - Stara oznaka OK-120-01	-	
345.004		- Odbojnik na ramu FT-0705 - Stara oznaka OK-120-02	ELASTRON G	
345.005		- Odbojnik na krilu FT-0710 za podizno klizni - Stara oznaka OK-120-02-A	ELASTRON G	
345.006		- Odbojnik na ramu FT-0701 za klizni - Stara oznaka OK-120-03	ELASTRON G	
345.007		- Odbojnik na ramu FT-0703 za klizni - Stara oznaka OK-120-04	ELASTRON G	
370.000 370.001 370.002		- Podmetači za staklo 3 mm 370.000 5 mm 370.001 7 mm 370.002 - Stara oznaka 210001319	PVC	

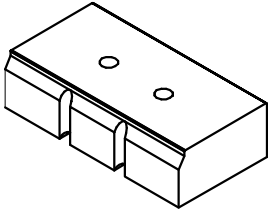
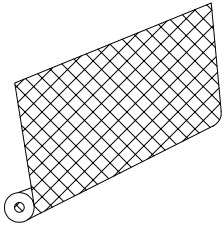
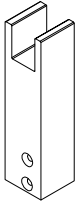
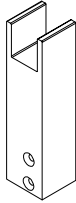
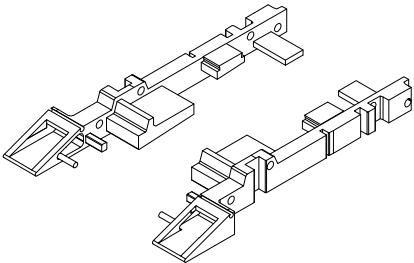
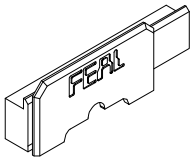
Oznaka	Izgled-presjek	Opis	Materijal	Nap.
363.019		- Gumeni umetak za podizno klizno Termo 120+	Meka guma	
340.047		- Mreža komarice	PVC	
373.060		- Usmjerivač krila FT-0725F	PVC	
373.061		- Usmjerivač krila FT-0710 i FT-0711	PVC	
375.065		- Bočni čepovi za niski prag Termo 120-D plus	PVC	
375.066		- Donji čep maske krila za Termo 120-D plus niski prag-lijevi	PVC	

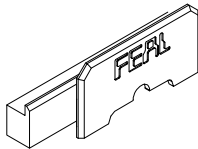
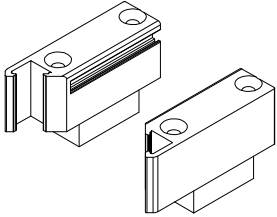
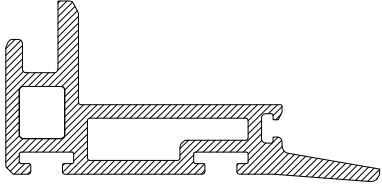
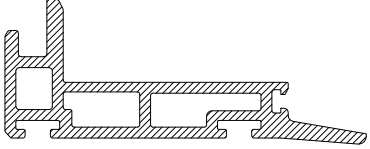
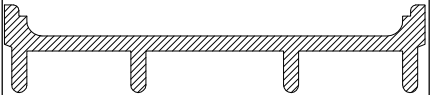
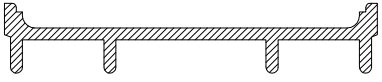
Oznaka	Izgled-presjek	Opis	Materijal	Nap.
375.067		- Donji čep maske krila za Termo 120-D plus niski prag-desni	PVC	
363.049		- Čep umetka za spoj dva krila pod 90°	Tvrda guma	
374.088		- Umetak na spoju dva krila (malo krilo FT-0711)	PVC	
374.075	 M 1:1.25	- Pvc umetakna spoju dva krila i krila i prečke - Krilo FT-0710	PVC	
374.026.01 02 03		- Umetak rama FT-0701 (isporuka u boji po RAL karti) - Stara oznaka PVC-103	PVC	
374.051	 M 1:1.25	- Pvc umetak u ramu FT-0720F	PVC	

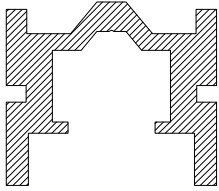
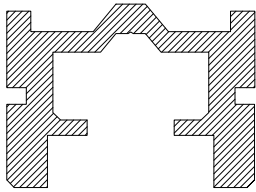
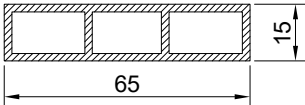
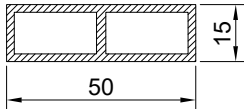
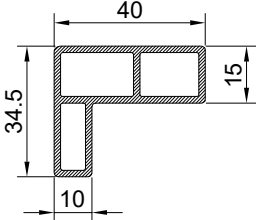

Oznaka	Izgled-presjek	Opis	Materijal	Nap.
374.027		- Umetak za klizno (krilo FT-0710) - Stara oznaka PVC-N1	PVC	
374.042		- Umetak za kotačiće HS-250 (podizno klizno) krilo TI 917/918	PVC	
374.052		- Pvc umetak u krilu FT-0725F za kotačiće HS-250	PVC	
374.068		- Umetak za kotačiće podizno kliznog mehanizma (niski prag)	PVC	
374.096		- Umetak za kotačiće podizno kliznog i kliznog mehanizma Hautau za krilo FT-0711	PVC	
374.034.01 02 03		- Umetak za ram - Stara oznaka PAM1	POLIAMID	

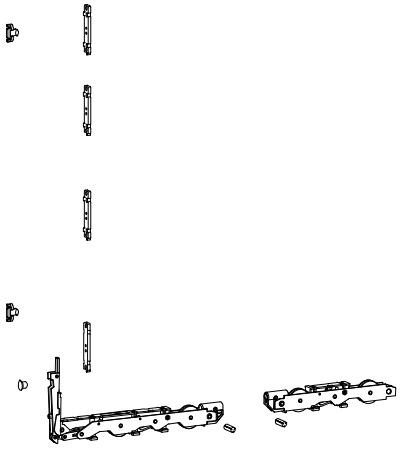
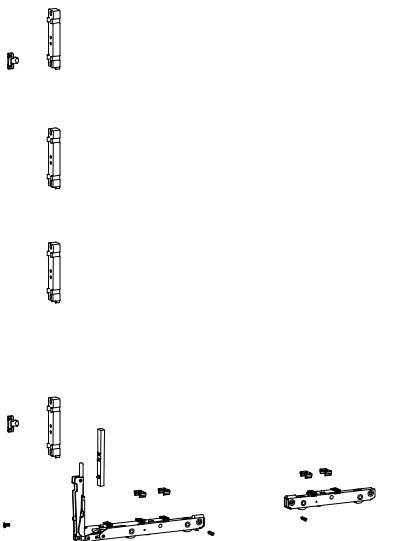
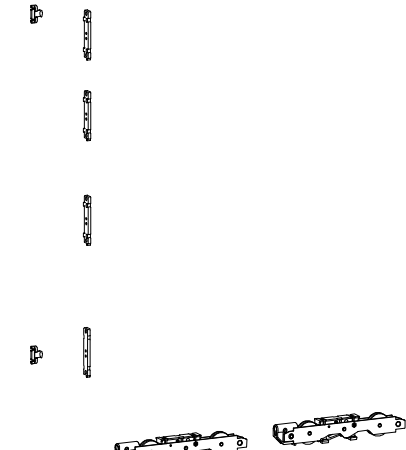

Oznaka	Izgled-presjek	Opis	Materijal	Nap.
374.028		- Umetak za podizno klizno-za bravu (krilo FT-0710) - Stara oznaka PVC-N2	PVC	
374.060		- Umetak za podizno klizno-za bravu (krilo FT-0725F) - Stara oznaka PVC-N2	PVC	
374.069	 M1:2	- PVC profil za ugradnju (65x15)	PVC	
374.070	 M1:2	- PVC profil za ugradnju (50x15)	PVC	
374.037	 M1:2	- PVC profil za ugradnju		

# Mehanizmi

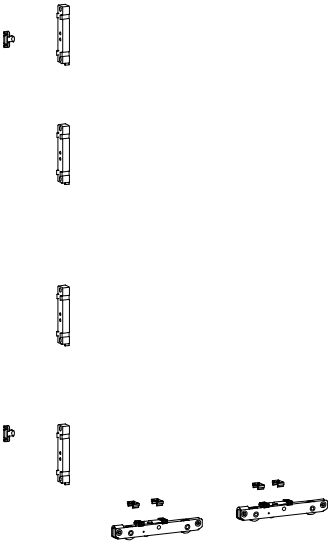

Oznaka	Izgled-presjek	Opis	Materijal	Nap.
149.033		<ul style="list-style-type: none"> <li>- Osnovni set za podizno klizna vrata Termo 120 (krilo FT-0710 i FT-0725F)</li> <li>- Hautau (kotači 330 kg-Atrium HS 330)</li> </ul>		
149.034		<ul style="list-style-type: none"> <li>- Osnovni set za podizno klizna vrata Termo 120 (krilo FT-0711)</li> <li>- Hautau (kotači 200 kg-Atrium HS 200)</li> </ul>		
149.039		<ul style="list-style-type: none"> <li>- Osnovni set za klizna vrata Termo 120 (krilo FT-0710 i FT-0725F)</li> <li>- Hautau (kotači 330 kg-Atrium HS 330)</li> </ul>		

Oznaka	Izgled-presjek	Opis	Materijal	Nap.
149.040		<ul style="list-style-type: none"> <li>- Osnovni set za klizna vrata Termo 120 (krilo FT-0711)</li> <li>- Hautau (kotači 200 kg-Atrium HS 200)</li> </ul>		
149.007		<ul style="list-style-type: none"> <li>- Brava za ključanje HS 200 vel. 180</li> <li>- Oznaka proizvođača 195419 (Fh 1200-1800)</li> </ul>		
149.008		<ul style="list-style-type: none"> <li>- Brava za ključanje HS 200 vel. 210</li> <li>- Oznaka proizvođača 195425 (Fh 1801-2100)</li> </ul>		
149.009		<ul style="list-style-type: none"> <li>- Brava za ključanje HS 200 vel. 240</li> <li>- Oznaka proizvođača 195431 (Fh 2101-2400)</li> </ul>		
149.010		<ul style="list-style-type: none"> <li>- Brava za ključanje HS 200 vel. 270</li> <li>- Oznaka proizvođača 195437 (Fh 2401-2700)</li> </ul>		
149.036		<ul style="list-style-type: none"> <li>- Brava za ključanje HS 120 vel. 180</li> <li>- Oznaka proizvođača 246866 (Fh 1200-1800)</li> </ul>		
149.037		<ul style="list-style-type: none"> <li>- Brava za ključanje HS 120 vel. 210</li> <li>- Oznaka proizvođača 246869 (Fh 1801-2100)</li> </ul>		
149.038		<ul style="list-style-type: none"> <li>- Brava za ključanje HS 120 vel. 240</li> <li>- Oznaka proizvođača 246872 (Fh 2101-2400)</li> </ul>		

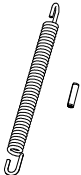
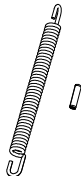
Oznaka	Izgled-presjek	Opis	Materijal	Nap.
149.004		<ul style="list-style-type: none"> <li>- Zatvarač donji i ventilacija (HAUTAU)</li> <li>- Oznaka proizvođača: 214404</li> </ul>		
149.006		<ul style="list-style-type: none"> <li>- Zatvarač gornji (HAUTAU)</li> <li>- Oznaka proizvođača: 214401</li> </ul>		
149.017		<ul style="list-style-type: none"> <li>- Donje ključanje-prag (HAUTAU)</li> <li>- Oznaka proizvođača: 186934</li> </ul>		
149.043		<ul style="list-style-type: none"> <li>- Opruga za bravu podizno kliznog mehanizma (lakše otvaranje ručke) &lt; 200 kg</li> <li>- Oznaka proizvođača: 239654 (Atrium HS -Soft Lift-HAUTAU)</li> </ul>		
149.044		<ul style="list-style-type: none"> <li>- Opruga za bravu podizno kliznog mehanizma (lakše otvaranje ručke) &gt; 200 kg</li> <li>- Oznaka proizvođača: 239657 (Atrium HS -Soft Lift-HAUTAU)</li> </ul>		

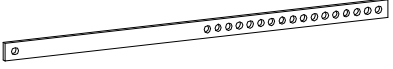
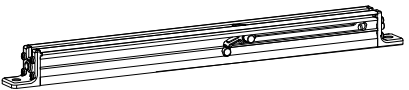
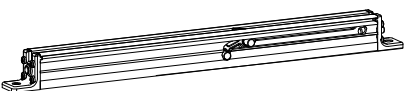
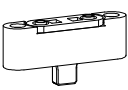
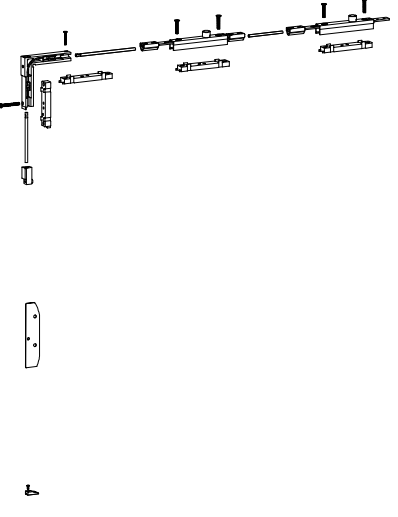
Oznaka	Izgled-presjek	Opis	Materijal	Nap.
149.011		- Spojnica kotačića vel. 150 (HAUTAU) - Oznaka proizvođača 184578 (Fb 720-1500)		
149.012		- Spojnica kotačića vel. 200 - Oznaka proizvođača 184581 (Fb 1501-2000)		
149.013		- Spojnica kotačića vel. 250 - Oznaka proizvođača 184584 (Fb 2001-2500)		
149.014		- Spojnica kotačića vel. 323 - Oznaka proizvođača 184587 (Fb 2501-3235)		
149.030		- Usporivač krila za težine krila ≤ 200 kg - Oznaka proizvođača:300359 (Atrium comfort close -HAUTAU)		
149.031		- Usporivač krila za težine krila > 200....300 kg - Oznaka proizvođača:300360 (Atrium comfort close -HAUTAU)		
149.032		- Usporivač krila-dodatak na ramu - Oznaka proizvođača:300380 (Atrium comfort close -HAUTAU)		
149.042		- Osnovni komplet za protuprovalnost WK2 - Oznaka proizvođača:228487 (Atrium HS -Safe - HAUTAU)		

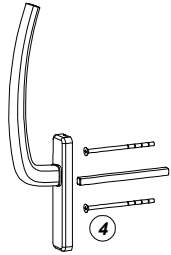
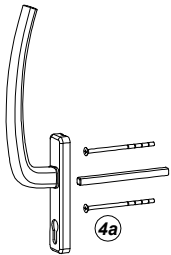
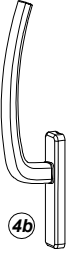
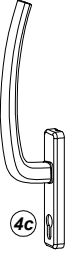
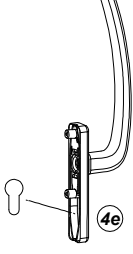
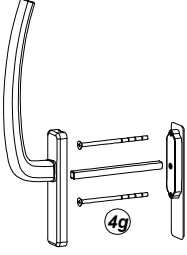
Oznaka	Izgled-presjek	Opis	Materijal	Nap.
<b>108.001.01</b> <b>03</b> <b>04</b> <b>06</b>		- Unutarnja ručka (bez vanjskog prihvatnika) - Oznaka proizvođača    196853    (RAL 9016) 196859    (crna) na upit    (natural) 246230    (srebrena)	Hautau	
<b>108.002.01</b> <b>03</b> <b>04</b> <b>06</b>		- Unutarnja ručka sa cilindrom za ključanje (bez vanjskog prihvatnika) - Oznaka proizvođača    196868    (RAL 9016) 196871    (crna) na upit    (natural) 246242    (srebrena)	Hautau	
<b>108.003.01</b> <b>03</b> <b>04</b> <b>06</b>		- Unutarnja ručka (bez vanjskog prihvatnika i osovine) -Oznaka proizvođača    246287    (RAL 9016) 246272    (crna) 246182    (natural) 246236    (srebrena)	Hautau	
<b>108.004.01</b> <b>03</b> <b>04</b> <b>06</b>		- Unutarnja ručka sa cilindrom za ključanje (bez vanjskog prihvatnika osovine) - Oznaka proizvođača    246290    (RAL 9016) 246275    (crna) 246185    (natural) 246248    (srebrena)	Hautau	
<b>108.005.01</b> <b>03</b> <b>04</b> <b>06</b>		- Vanjska ručka sa cilindrom za ključanje (bez osovine) -Oznaka proizvođača    246293    (RAL 9016) 246278    (crna) 246188    (natural) 246254    (srebrena)	Hautau	
<b>108.006.01</b> <b>03</b> <b>04</b> <b>06</b>		- Unutarnja ručka -set - Oznaka proizvođača    185170    (RAL 9016) 193615    (crna) 204553    (natural) 246227    (srebrena)	Hautau	

Oznaka	Izgled-presjek	Opis	Materijal	Nap.
<b>108.007.01</b> <b>03</b> <b>04</b> <b>06</b>		- Unutarnja ručka-set (sa cilindrom za ključanje) - Oznaka proizvođača    186982    (RAL 9016) 193618    (crna) 204556    (natural) 246239    (srebrena)	Hautau	
<b>108.008.01</b> <b>03</b> <b>04</b> <b>06</b>		- Pogonske ručke-set (sa cilindrom za ključanje) - Oznaka proizvođača    185179    (RAL 9016) 193621    (crna) 206863    (natural) 246251    (srebrena)	Hautau	
<b>108.010.01</b> <b>04</b> <b>05</b>		- Unutarnja ručka za Termo 120-malo krilo (bez vanjskog prihvatnika) -Oznaka proizvođača    206209    (bijela) 206206    (elox) 207361    (smeđa)	Hautau	
<b>108.011.01</b> <b>04</b> <b>05</b>		- Unutarnja ručka za Termo 120-malo krilo (bez vanjskog prihvatnika) sa ključem -Oznaka proizvođača    206218    (bijela) 206215    (elox) 207367    (smeđa)	Hautau	
<b>108.009.01</b> <b>03</b> <b>04</b> <b>06</b>		-Standardni vanjski rukohvatnik 9.5 mm - Oznaka proizvođača    185161    (RAL 9016) 193600    (crna) 185158    (natural) 224259    (srebrena)	Hautau	
<b>108.012.01</b> <b>06</b>		-Ravni vanjski rukohvatnik	Hautau	

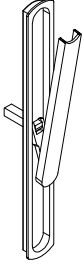
Oznaka	Izgled-presjek	Opis	Materijal	Nap.
<b>100.016.01</b> <b>02</b> <b>03</b>		<ul style="list-style-type: none"> <li>- Ukupavajuća ručka za podizno klizna vrata</li> <li>- Oznaka proizvođača:            PHIB0100-00401 (RAL 9016)....01            PHIB0100-02501 (EV1 silber Si-silber)..02            PHIB0100-02301 (RAL 9005).....03</li> </ul>	Siegenia	

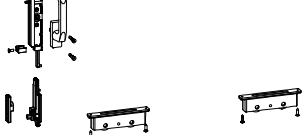
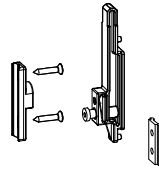
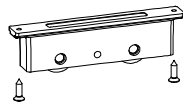
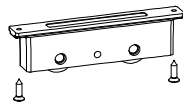
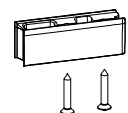
Oznaka	Izgled-presjek	Opis	Materijal	Nap.
133.006		- Osnovni komplet za klizno Notter - Stara oznaka 084 850 00 (za vodilicu F-1112)	-	
133.007		- Osnovni komplet za klizno - Stara oznaka 007 850 00 (za vodilicu od poliamida ili kad kotačići klize po aluminiju)	-	
133.008		- Dodatno ključanje po visini (FH 1401-2400) - Stara oznaka 007 851 00	-	
133.009		- Dodatno kotačići za klizno (Fb >1400) - Stara oznaka 084 852 00 (za vodilicu F-1112)	-	
133.010		- Dodatno kotačići za klizno (Fb >1400) - Stara oznaka 007 852 00 (za vodilicu od poliamida ili kad kotačići klize po aluminiju)	-	
133.011		- Dodatni zapinjač za kratko otvaranje krila radi ventilacije - Stara oznaka 007 853 00	-	

Oznaka	Izgleđ-presjek	Opis	Materijal	Nap.
101.011.04 02 06 07 01		- Ručka za klizno Notter - Stara oznaka 020 314 01	(elox srebrna) (elox smeđa) (srebrna) (smeđa) (bijela)	-
101.012.04 02 06 07 01		- Ručka za klizno Notter - Stara oznaka 020 315 01	(elox siva) (elox smeđa) (srebrna) (smeđa) (bijela)	-
101.003.04 02 01		- Ručka za klizno Notter - Stara oznaka 020 221 01	(elox siva) (elox smeđa) (bijela)	-
101.013.04 02 01		- Ručka za klizno Notter - Stara oznaka 021 221 01	(elox siva) (elox smeđa) (bijela)	-
101.014.04 02 06 07 01		- Ručka za klizno Notter - Stara oznaka 020 915 01	(elox siva) (elox smeđa) (srebrna) (smeđa) (bijela)	-









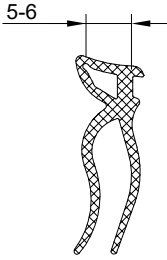
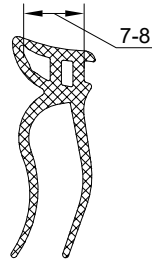
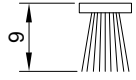
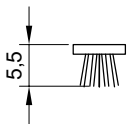
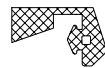
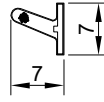

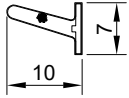
Brtvila

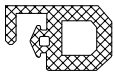

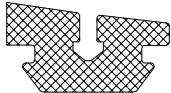
Oznaka	Izgled-presjek	Opis	Materijal	Nap.
321.002		<ul style="list-style-type: none"> <li>- Brtva prema staklu /vanjska/</li> <li>- Stara oznaka 210.001.140 (Z111)</li> </ul>	EPDM	
321.003		<ul style="list-style-type: none"> <li>- Brtva prema staklu /vanjska/</li> <li>- Stara oznaka 210.001.142 (Z113)</li> </ul>	EPDM	
344.014		<ul style="list-style-type: none"> <li>- Brtva vertikalnog pojasa krila</li> <li>- Stara oznaka ART-3866</li> </ul>	EPDM	
311.001		<ul style="list-style-type: none"> <li>- Brtva prema staklu /unutarnja/</li> <li>- Stara oznaka 210.001.125 (921)</li> </ul>	EPDM	
311.002		<ul style="list-style-type: none"> <li>- Brtva prema staklu /unutarnja/</li> <li>- Stara oznaka 210.001.123 (918)</li> </ul>	EPDM	
311.003		<ul style="list-style-type: none"> <li>- Brtva prema staklu /unutarnja, nosi 3-4 mm/</li> </ul>	EPDM	

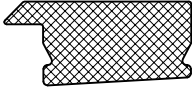
Oznaka	Izgled-presjek	Opis	Materijal	Nap.
311.004		- Brtva prema staklu /unutarnja,nosi 5-6 mm/	EPDM	
311.005		- Brtva prema staklu /unutarnja,nosi 7-8 mm/	EPDM	
347.003		- Četkasta brtva 7x9 - Star oznaka PB*HFC	PP	
347.004		- Četkasta brtva 7x5.5 - Stara oznaka PB*HFC	PP	
344.015		- Brtva fiksnog krila - Stara oznaka B-IF-01	TPE	
347.011		- Brtva za podizno klizno (krilo FT-0710 i FT-0711)		

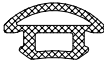
Oznaka	Izgled-presjek	Opis	Materijal	Nap.
347.012		- Brtva za podizno klizno (krilo FT-0725F)		
344.052.01 02 03		- Brtva za ramove T-120 - Isporuka u boji (crna, bijela, siva)	ELASTRON G SEBS	
344.048		- Brtva u krilu FT-0725F za podizno klizno	EPDM	
344.041		- Brtva za lajsnu u fiksnom dijelu	TPE	
344.054		- Brtva krila u donjem pojasu prema pragu	TPE	
344.055		- Brtva za masku F-1381-niski prag	TPE	

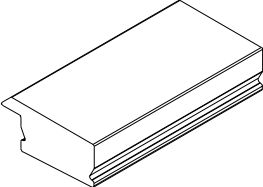
Oznaka	Izgled-presjek	Opis	Materijal	Nap.
344.068		- Brtva na fiksnom dijelu-niski prag sa kadicom	TPE	
344.073		- Brtva na spoju krila	TPE	
344.075		- Brtva na spoju krila pod 90°	TPE	
340.048		-Brtva - držač mreže -Stara oznaka 00600/55		
361.029		- Gumeni umetak u pragu između krila i prečke (niski prag)	TPE	

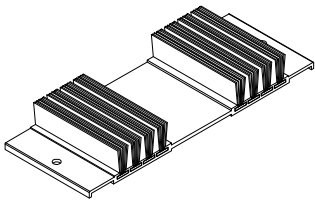
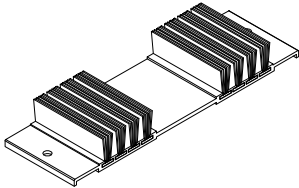
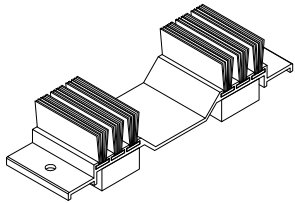
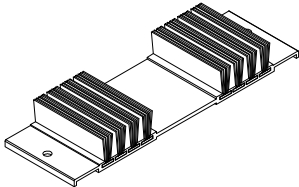
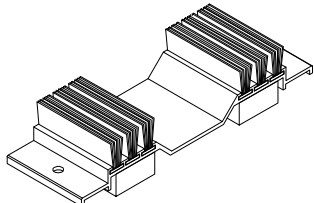
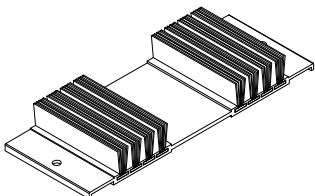
Oznaka	Izgled-presjek	Opis	Materijal	Nap.
340.046		- Umetak sa četkicom-spoj dva krila-(T120-D) - L=52.5 mm	-	
340.041		- Umetak sa četkicom-spoj dva krila-gornji-(T120 plus-D) - L=37.5 mm	-	
340.005		- Umetak sa četkicom-spoj dva krila-(T120plus) - Stara oznaka F 0853/33	-	
340.402		- Umetak sa četkicom-spoj dva krila-(T120 plus) - L=33 mm	-	
340.006		- Umetak sa četkicom-spoj dva krila-(T120) - Stara oznaka F 0853/46	-	
340.007		- Umetak sa četkicom-spoj dva krila-(T120) - Stara oznaka F 1008/46	-	

Oznaka	Izgled-presjek	Opis	Materijal	Nap.
360.012		<ul style="list-style-type: none"> <li>- Gumeni umetak donji za podizno klizno</li> <li>- Spoj dva krila FT-0710</li> <li>- Termo 120</li> <li>- Dimenzije: 48x13.5x110</li> </ul>	EPDM	
360.013		<ul style="list-style-type: none"> <li>- Gumeni umetak donji za podizno klizno</li> <li>- Spoj dva krila FT-0711</li> <li>- Termo 120</li> <li>- Dimenzije: 48x13.5x90</li> </ul>	EPDM	
360.014		<ul style="list-style-type: none"> <li>- Gumeni umetak donji za podizno klizno</li> <li>- Spoj dva krila FT-0725F</li> <li>- Termo 120-D</li> <li>- Dimenzije: 54x12.5x110</li> </ul>	EPDM	
360.015		<ul style="list-style-type: none"> <li>- Gumeni umetak donji za podizno klizna vrata</li> <li>- Spoj dva krila FT-0725F</li> <li>- Termo 120-D plus</li> <li>- Dimenzije: 37x16x110</li> </ul>	EPDM	

# Dodaci

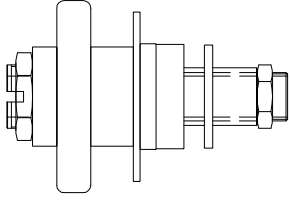
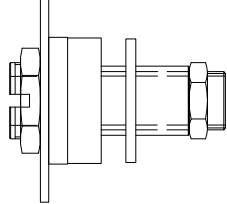
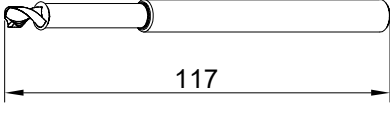

Oznaka	Izgled-presjek	Opis	Materijal	Nap.
220.008		<ul style="list-style-type: none"><li>- Grupa glodala za obradu prečke FT-0706 prema profilu rama FT-0705</li><li>- Stara oznaka GL-T120</li></ul>	-	
220.006		<ul style="list-style-type: none"><li>- Grupa glodala za obradu prečke prema profilu krila i rama</li><li>- Stara oznaka GRUPA GLODALA TERMO 50</li></ul>	-	
220.025		<ul style="list-style-type: none"><li>- Svrdo za proširenje rupe sa <math>\text{Ø}6.4</math> mm na <math>\text{Ø}8</math> mm (za kutnu spojnicu 710.227 - krilo T120)</li></ul>	Čelik	

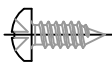
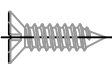
Oznaka	Opis	Izgled-presjek	Materijal	Napomena
433.003	Vijak 3.5x13 DIN 7981			
433.005	Vijak 3.5x19 DIN 7981			
433.007	Vijak 3.5x25 DIN 7981			
433.019	Vijak 3.9x22 DIN 7981			
433.021	Vijak 3.9x32 DIN 7981			
433.048	Vijak 4.8x45 DIN 7981			
433.049	Vijak 4.8x50 DIN 7981			
433.091	Vijak 3.5x13 DIN 7982			
433.092	Vijak 3.5x16 DIN 7982			
433.094	Vijak 3.5x22 DIN 7982			
433.095	Vijak 3.5x25 DIN 7982			
433.108	Vijak 3.9x25 DIN 7982			
433.116	Vijak 4.2x13 DIN 7982			
433.120	Vijak 4.2x25 DIN 7982			
433.121	Vijak 4.2x32 DIN 7982			

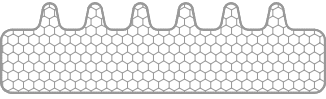
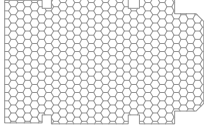
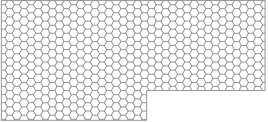
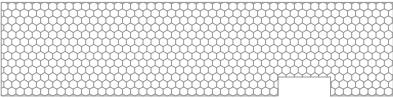
Oznaka	Izgled-presjek	Opis	Materijal	Nap.
348.001		- Ispuna ispod stakla - Stara oznaka CLIMAFILL		
340.013		- Izoterm plameframe		
340.044		- Izolacijski umetak na spoju dva krila	XPS	
340.042		- Izolacijski umetak na ramu T120 plus	XPS	
340.045		- Izolacijski umetak na spoju dva krila	XPS	

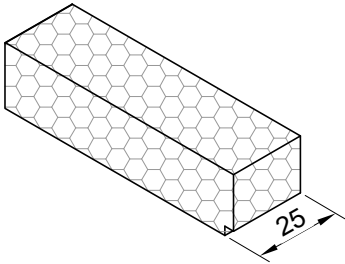
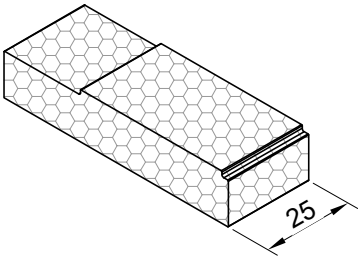
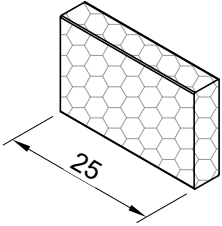
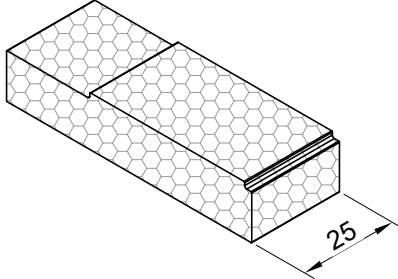
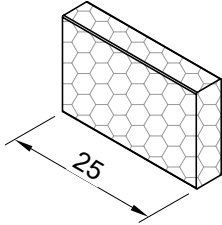
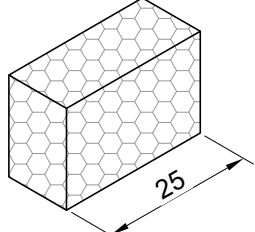
Oznaka	Izgled-presjek	Opis	Materijal	Nap.
340.331		-XPS barijera za komoru 43.3x11.2 - Za profil: FT-0701 (Termo 120)	XPS	
340.333		-XPS barijera za komoru 70.3x14.5 - Za profil: FT-0722F (Termo 120)	XPS	
340.335		-XPS barijera za komoru 5.1x16 -Za profil: FT-0722F (Termo 120)	XPS	
340.337		-XPS barijera za komoru 65.2x14.5 - Za profil: FT-0705 (Termo 120)	XPS	
340.339		-XPS barijera za komoru 8.5x16.2 - Za profil: FT-0705 (Termo 120)	XPS	
340.341		-XPS barijera za komoru 11.3x17 - Za profil: FT-0710 (Termo 120)	XPS	

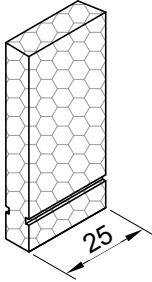
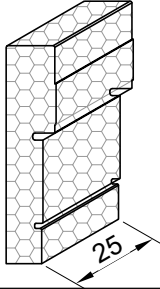
Oznaka	Izgled-presjek	Opis	Materijal	Nap.
340.343		-XPS barijera za komoru 7.9x57.1 - Za profil: FT-0710 (Termo 120)	XPS	
340.345		-XPS barijera za komoru 11.45x50.1 - Za profil: FT-0711 (Termo 120)	XPS	



# Obrada i montaža

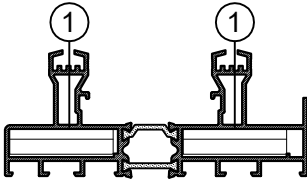
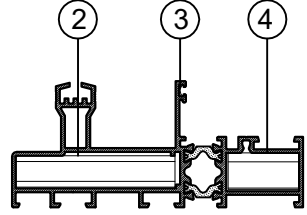
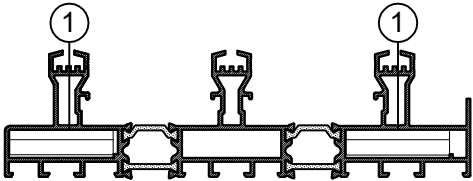
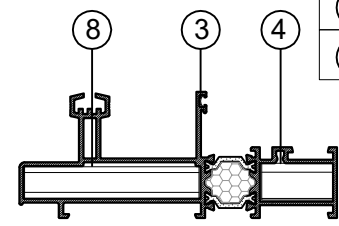
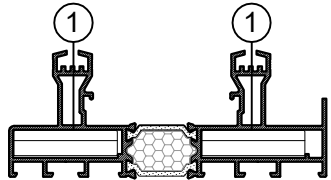
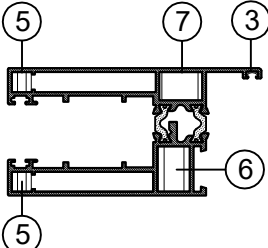
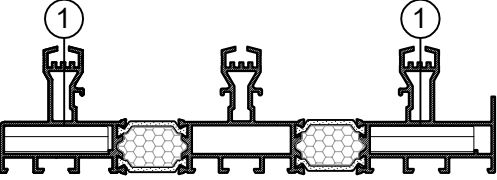
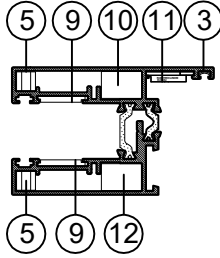
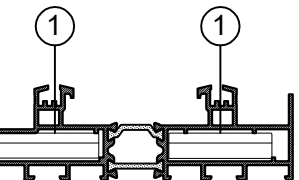
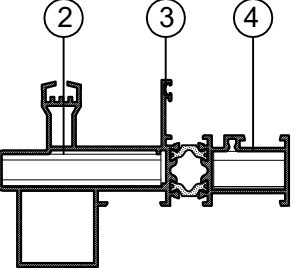
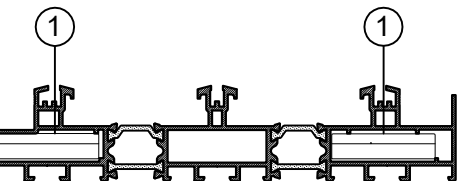

PRIKAZ KUTNIKA U PROFILIMA

<p>FT-0701</p> 	<p>① 730.013</p>	<p>FT-0705</p> 	<p>② 710.446 ③ 730.001 ④ 730.008</p>
<p>FT-0702</p> 	<p>① 730.013</p>	<p>FT-0722F</p> 	<p>⑧ 710.478 ③ 730.001 ④ 730.008</p>
<p>FT-0720F</p> 	<p>① 730.013</p>	<p>FT-0710 i FT-0725F</p> 	<p>③ 730.001 ⑤ 710.011 ⑥ 710.445 ⑦ 710.504</p>
<p>FT-0721F</p> 	<p>① 730.013</p>	<p>FT-0711</p> 	<p>③ 730.001 ⑤ 710.011 ⑨ 730.017 ⑩ 710.520 ⑪ 731.010 ⑫ 731.519</p>
<p>FT-0703</p> 	<p>① 730.013</p>	<p>FT-0707</p> 	<p>② 710.446 ③ 730.001 ④ 730.008</p>
<p>FT-0704</p> 	<p>① 730.013</p>		

## SPAJANJE PROFILA KUTNICIMA POD KUTEM OD 90°

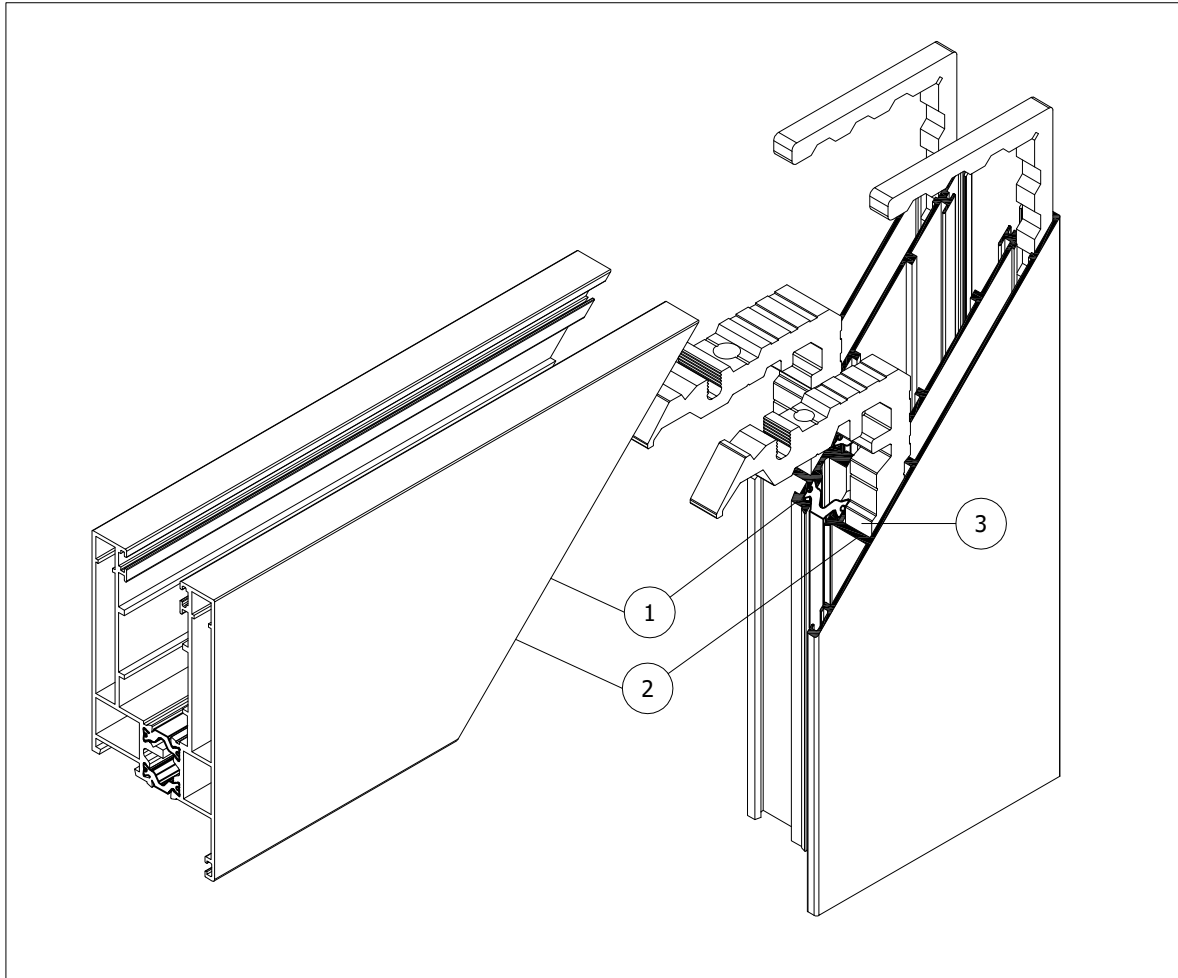

## POSTUPAK SPAJANJA PROFILA:

1. Sve površine koje se spajaju-rezove očistiti i odmastiti odgovarajućim sredstvom /npr. "Henkel" - *Teroson VR 20 ili Teroson FL+ I.*
2. Premazati sve površine koje se spajaju ljeplom za metal /npr. "Henkel" - *Teroson MS 939 I.*
3. Ljepilo za metal ubrizgati u komore za kutnik (po opsegu komore)
4. Profile s kutnicima izravnati i spojiti
5. Dio ljepila koji iscuri između rezova očistiti sredstvom za čišćenje i odmašćivanje /npr. "Henkel" - *Teroson VR 20 ili Teroson FL+ I.*

## NAPOMENA:

Ovaj postupak spajanja profila primjenjiv je za sve Feal-ove kutnike i njima odgovarajuće komore. Lijepljenjem rezova i kutnika ljeplima za metal, osigurava se potrebna zrako- i vodonepropusnosti spoja kao i dodatna mehanička čvrstoća spoja.

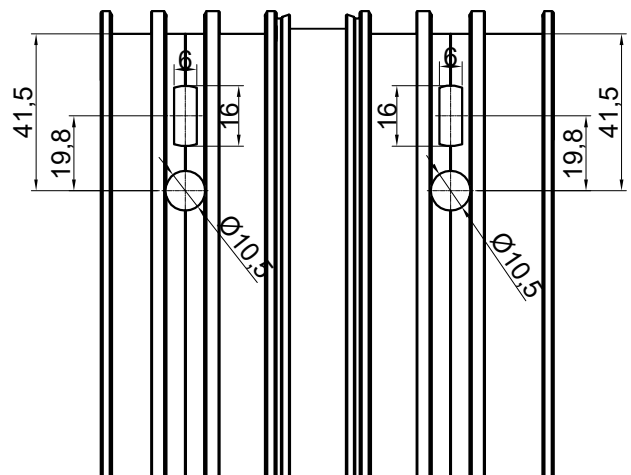
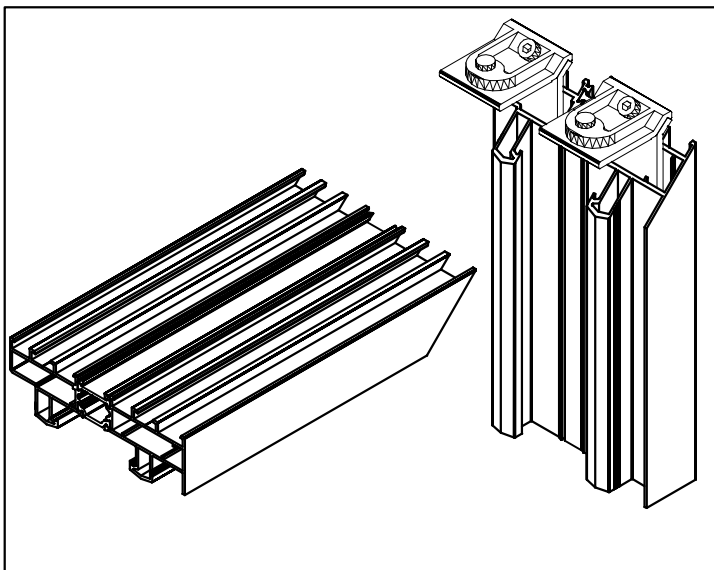
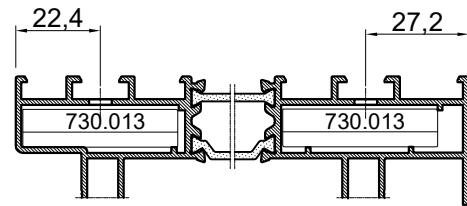
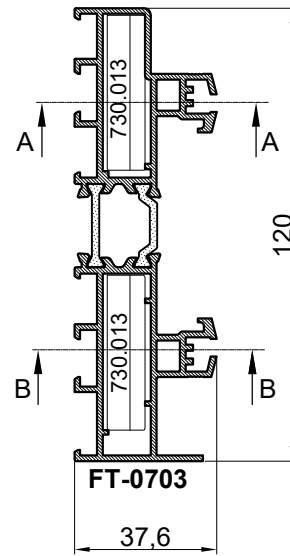
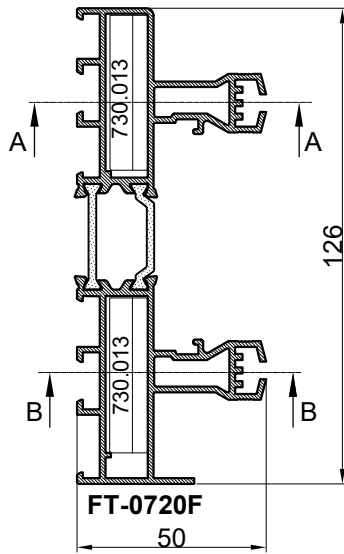
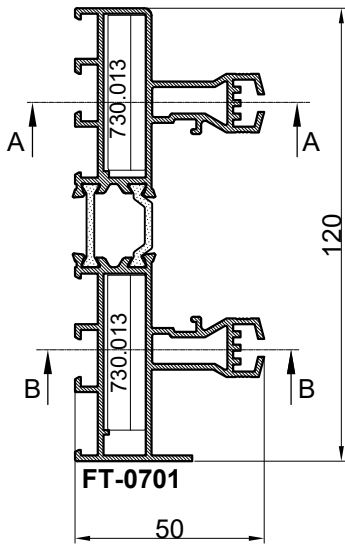
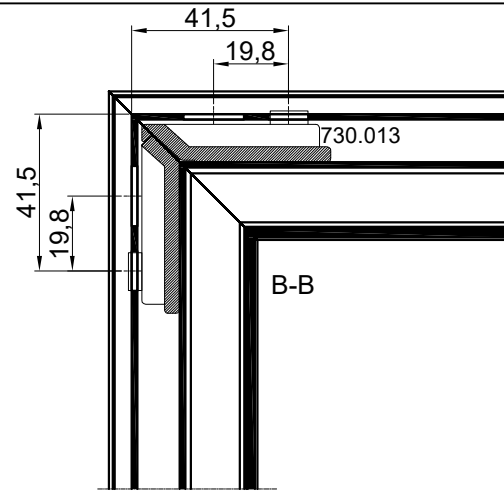
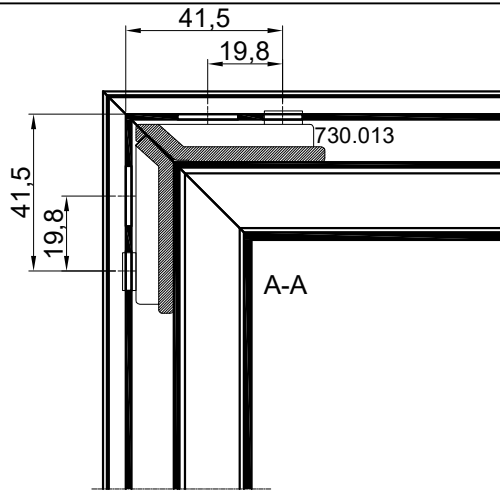

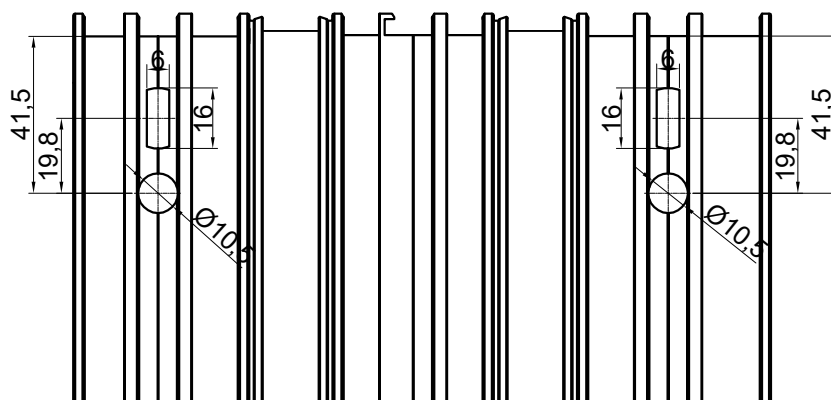
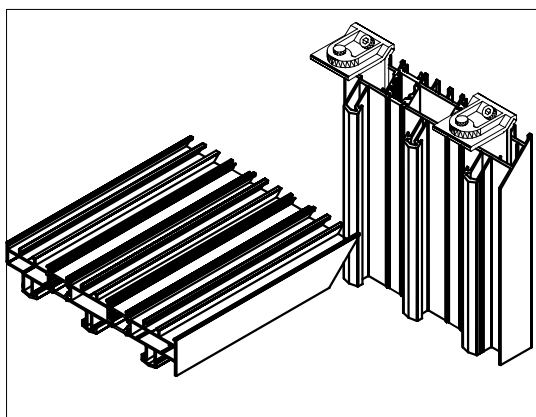
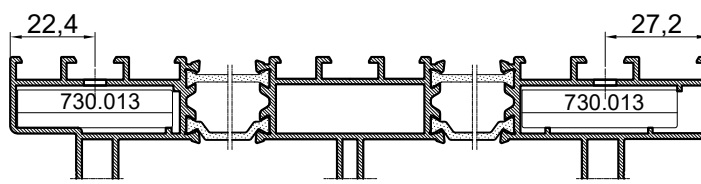
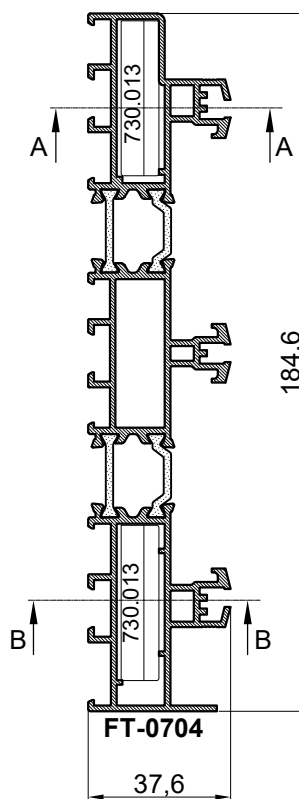
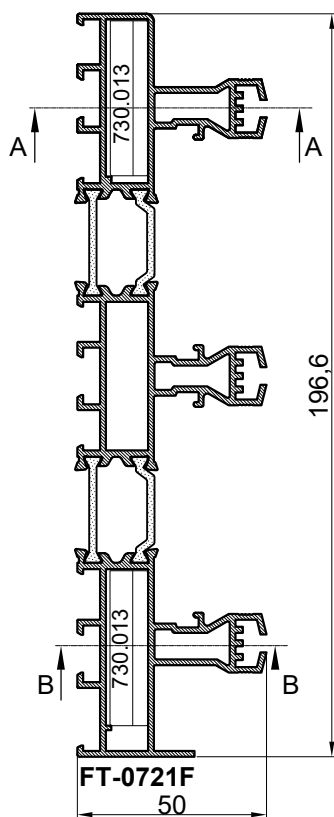
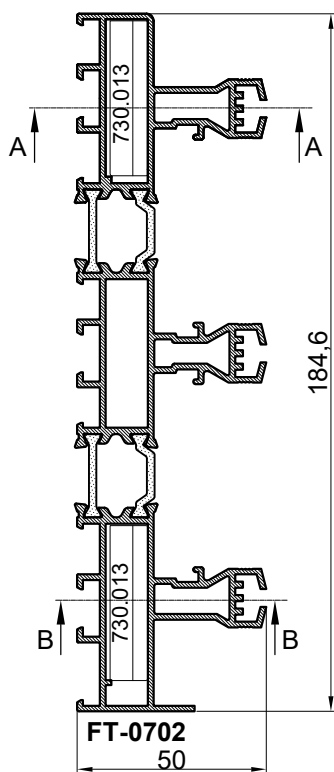
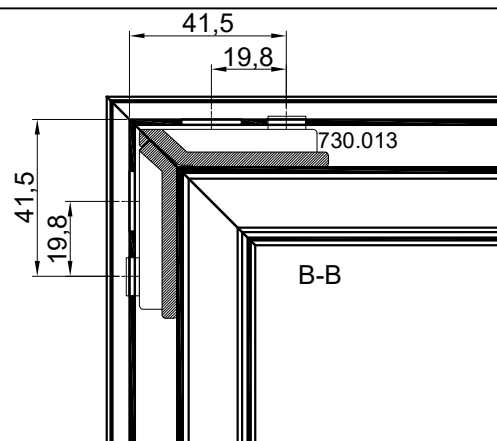
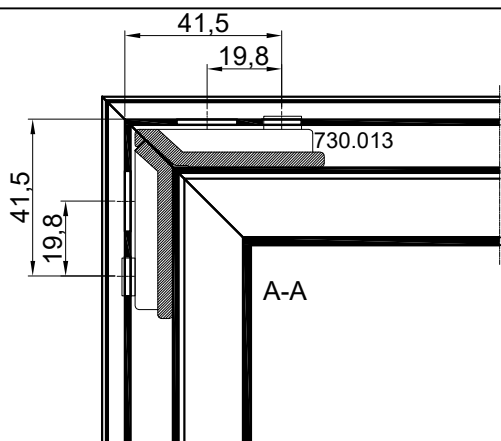

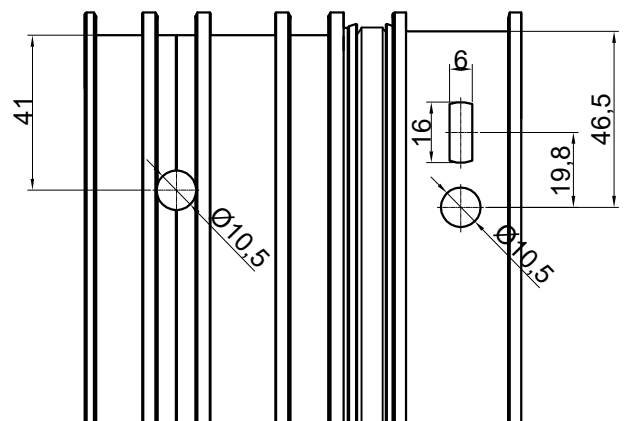
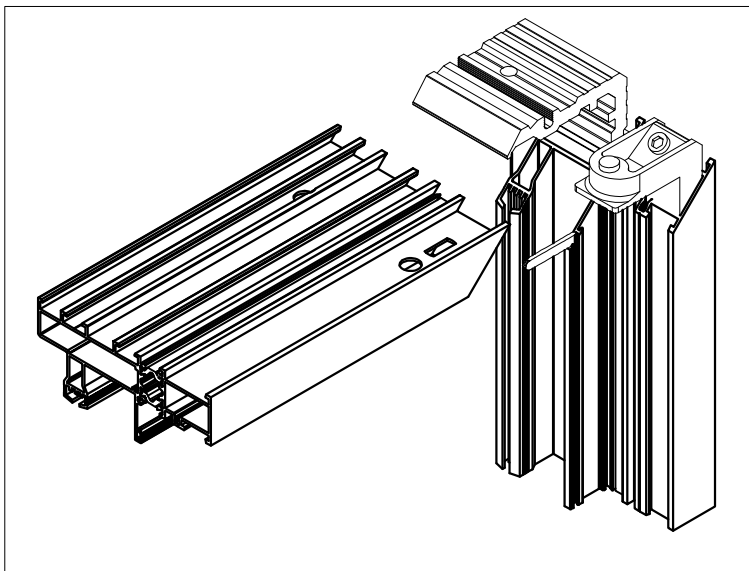
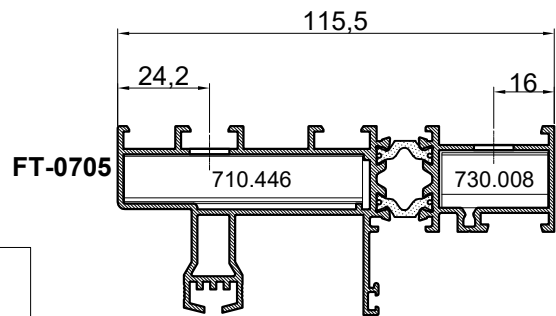
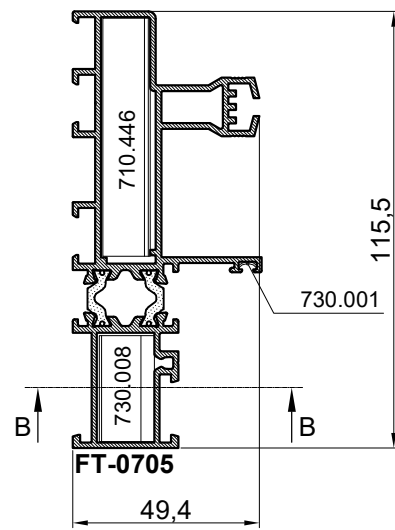
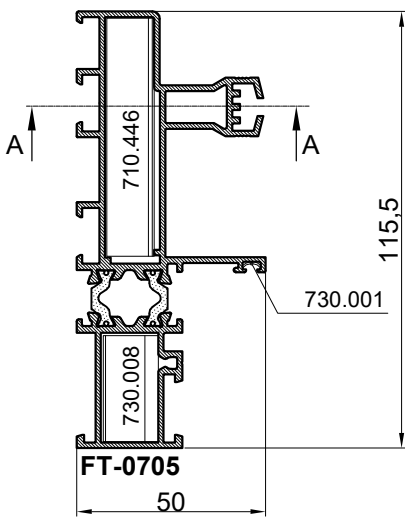
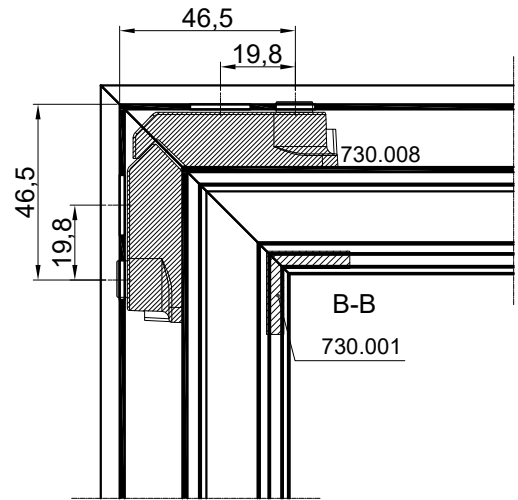
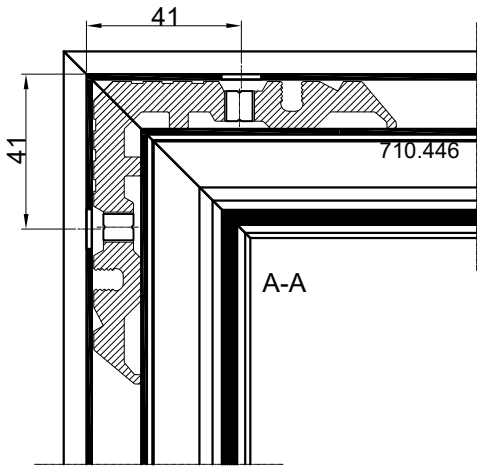

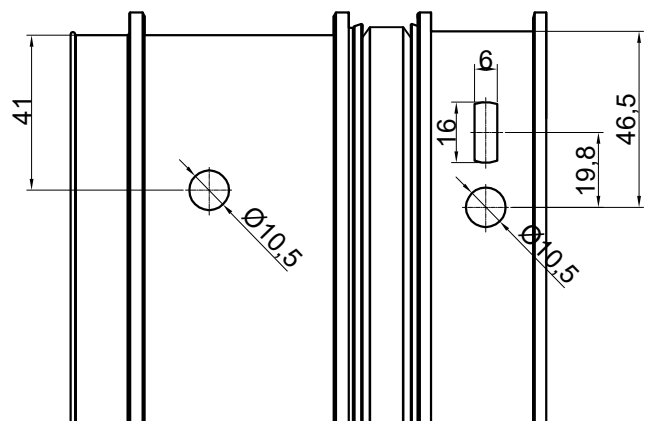
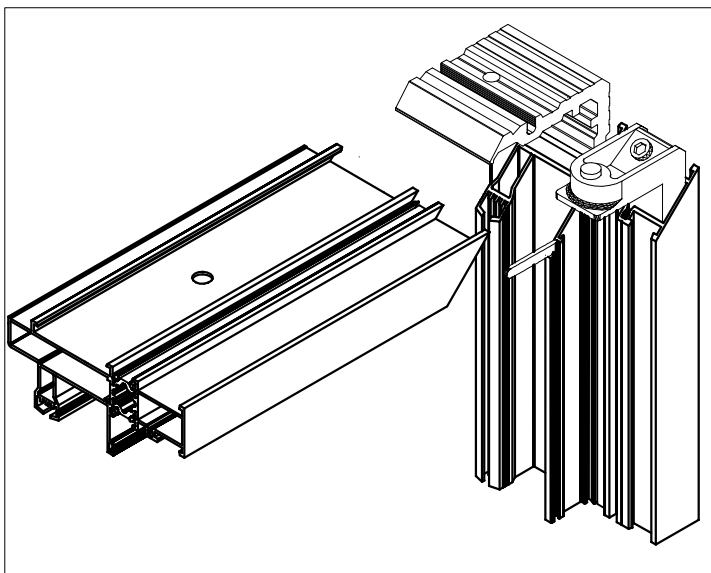
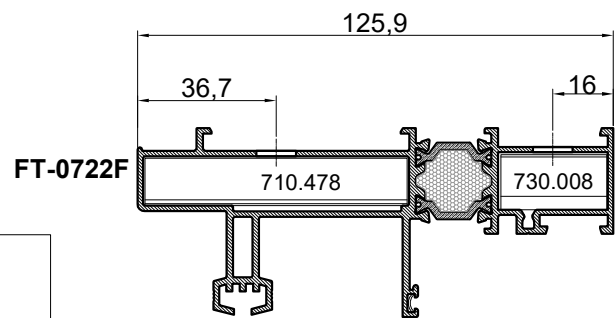
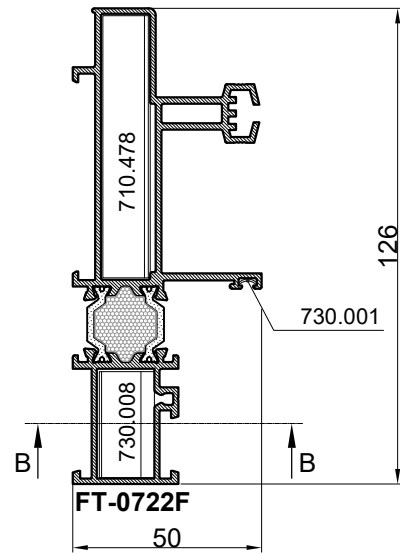
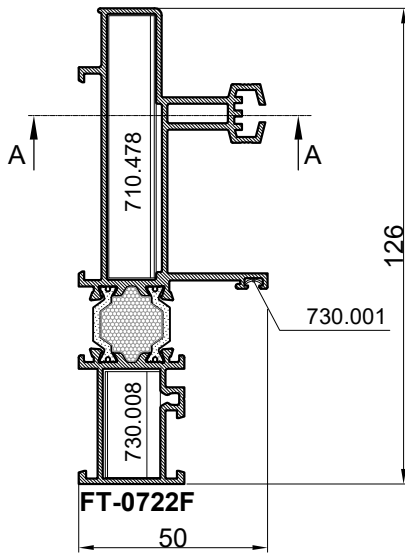
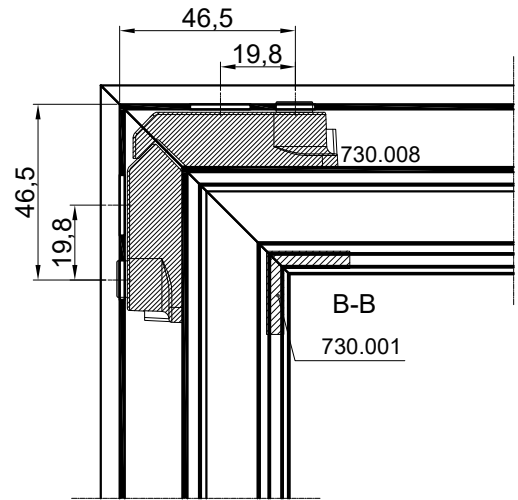
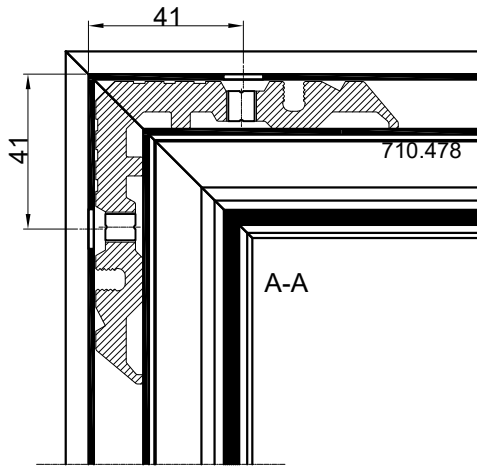

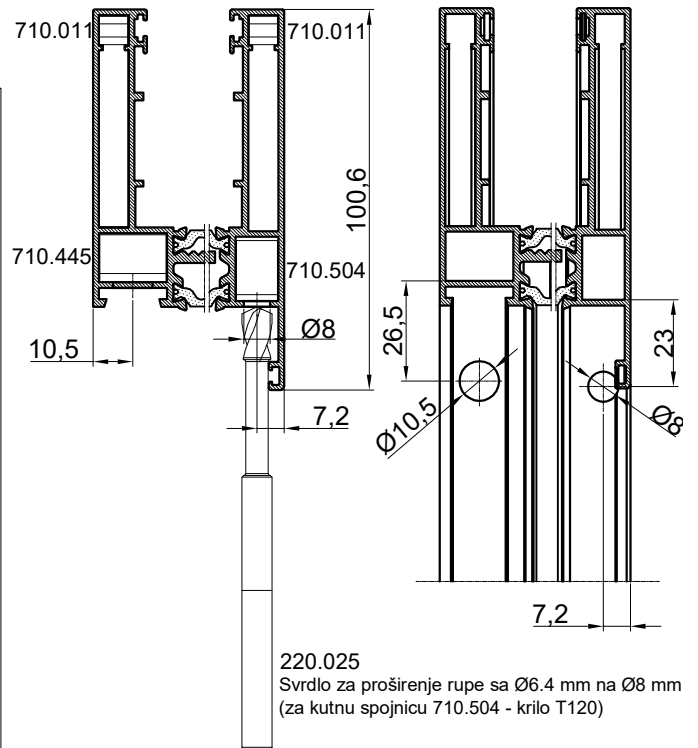
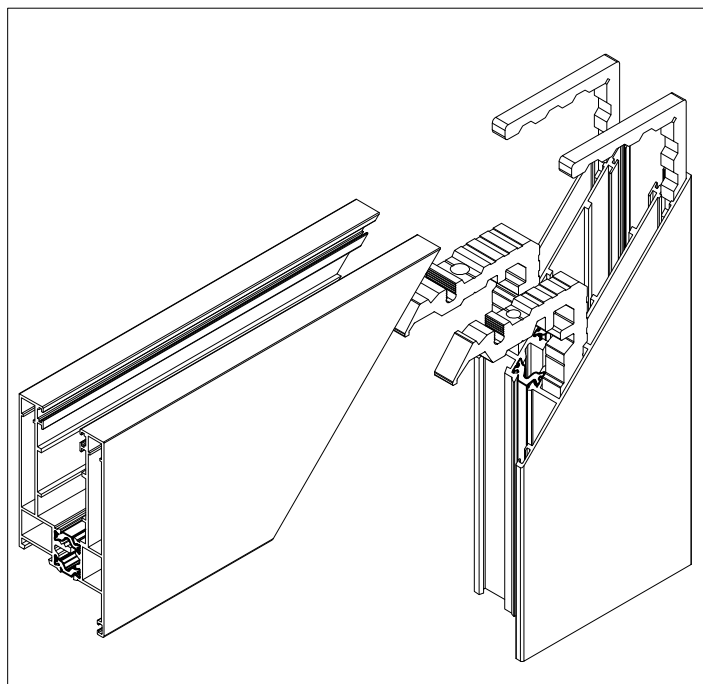
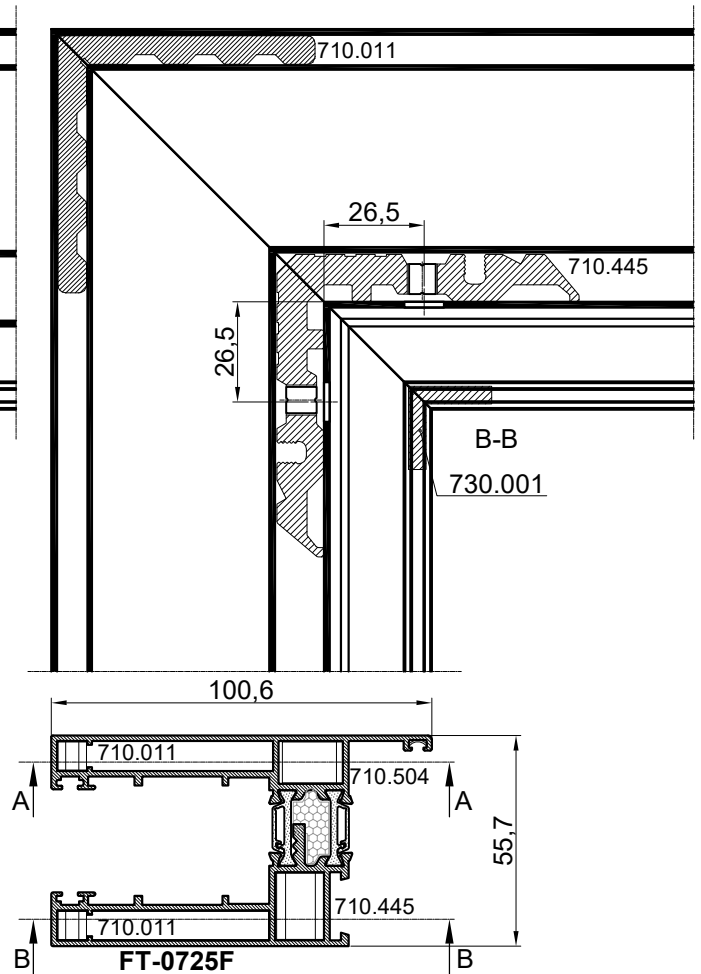
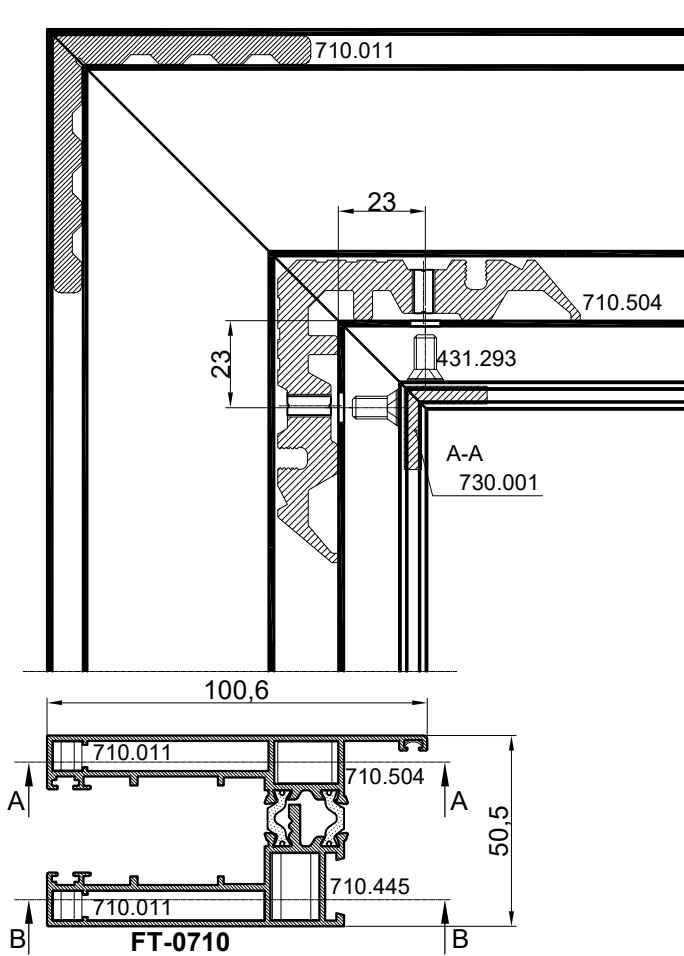

### BUŠENJE RUPE $\varnothing 8$ ZA KUTNIK 710.504:

1. RUPU PROMJERA  $\varnothing 6.4$  mm PROBIJA ŠTANCA U SREDINI KOMORE
2. POMOĆU SVRDLA ZA PROŠIRIVANJE (220.025) RUPU  $\varnothing 6.4$  PROŠIRITI NA  $\varnothing 8$  mm

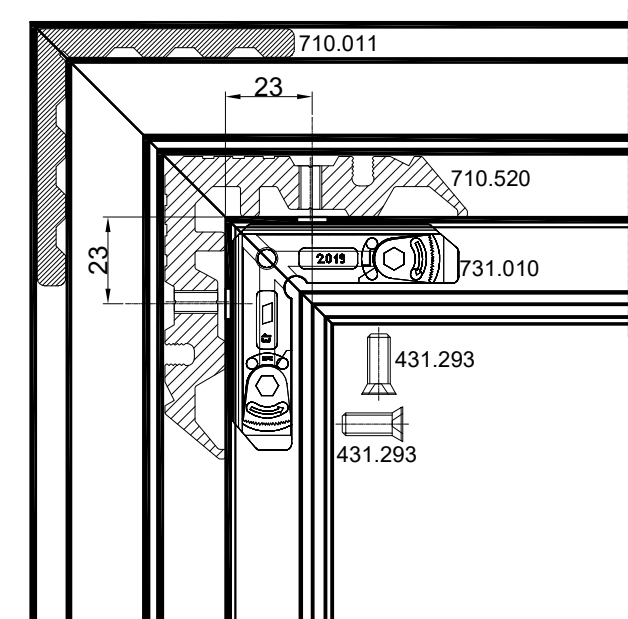

A-A

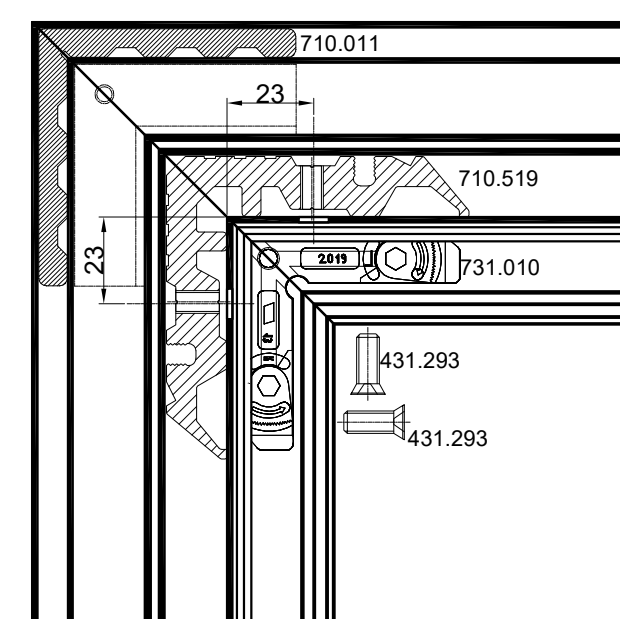

B-B

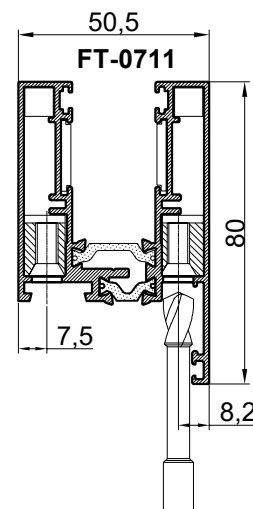
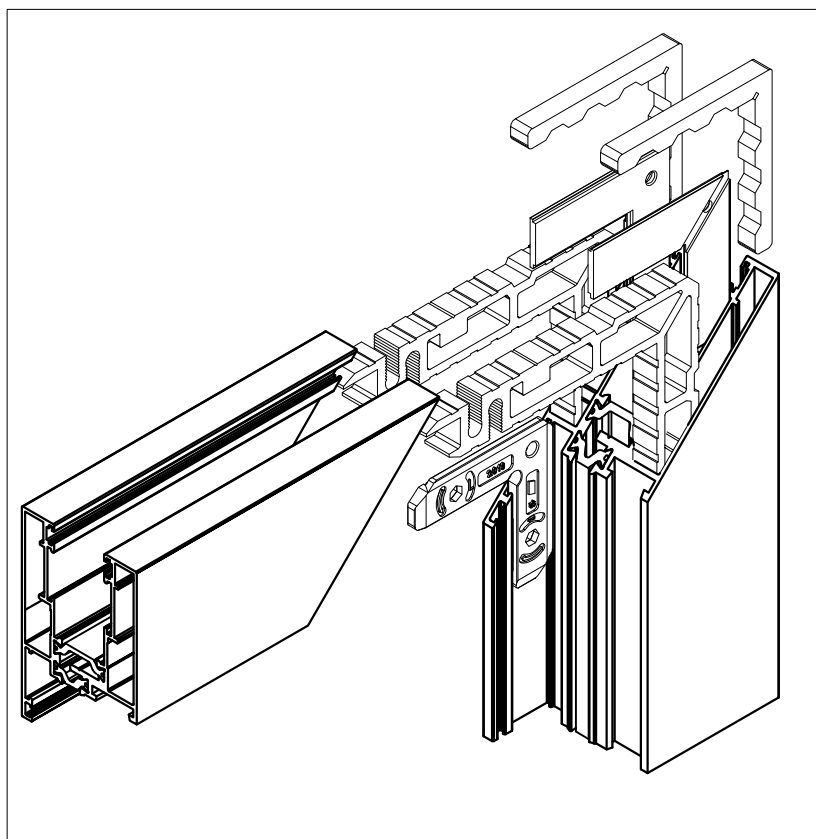
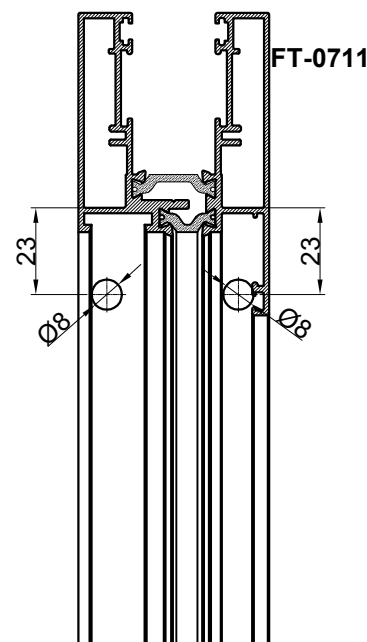
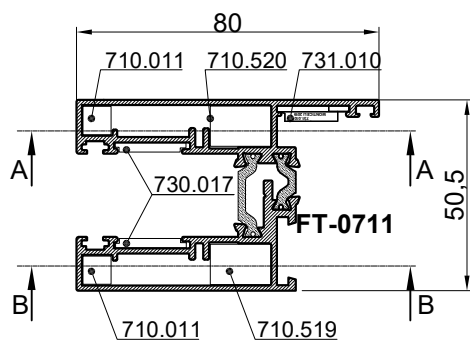

220.025  
Svrđlo za proširenje rupe sa  $\text{Ø}6.4$  mm na  $\text{Ø}8$  mm  
(za kutnu spojnicu 710.520 - krilo T120)

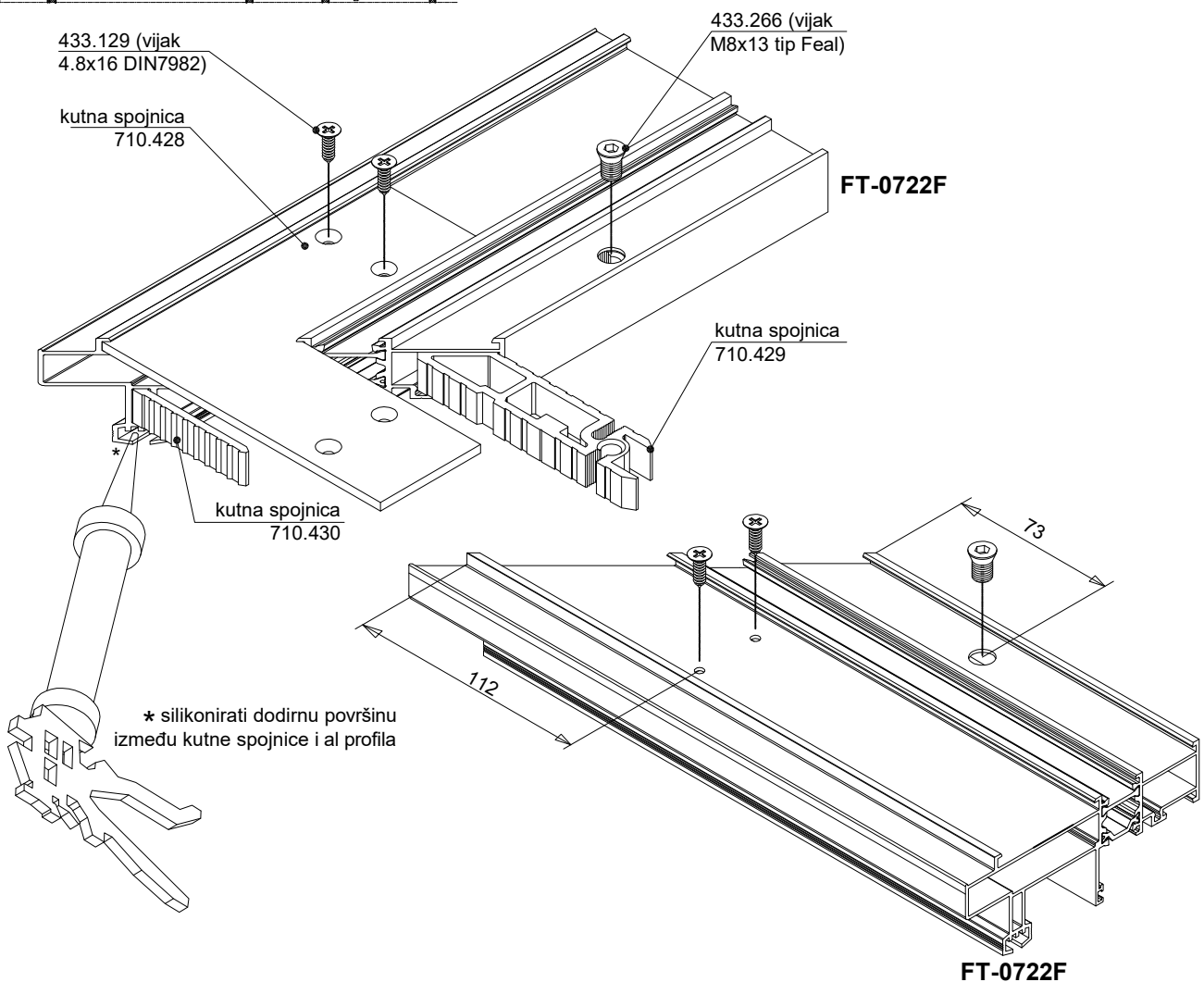
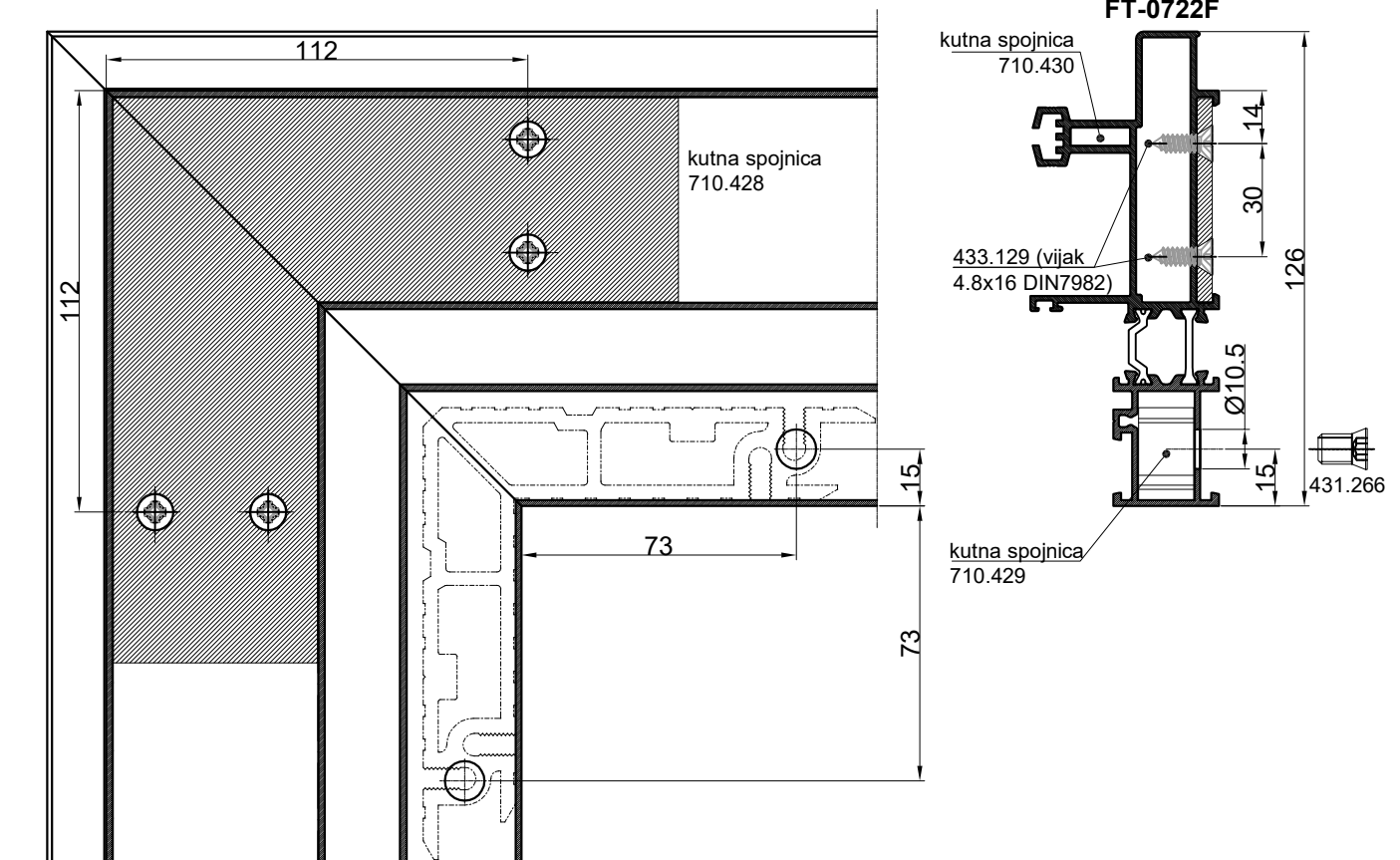

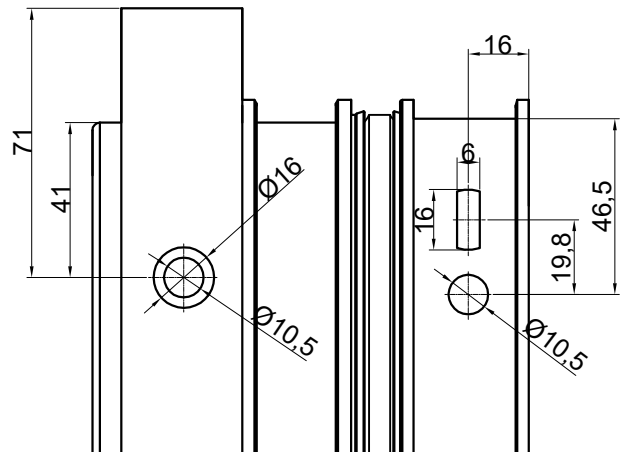
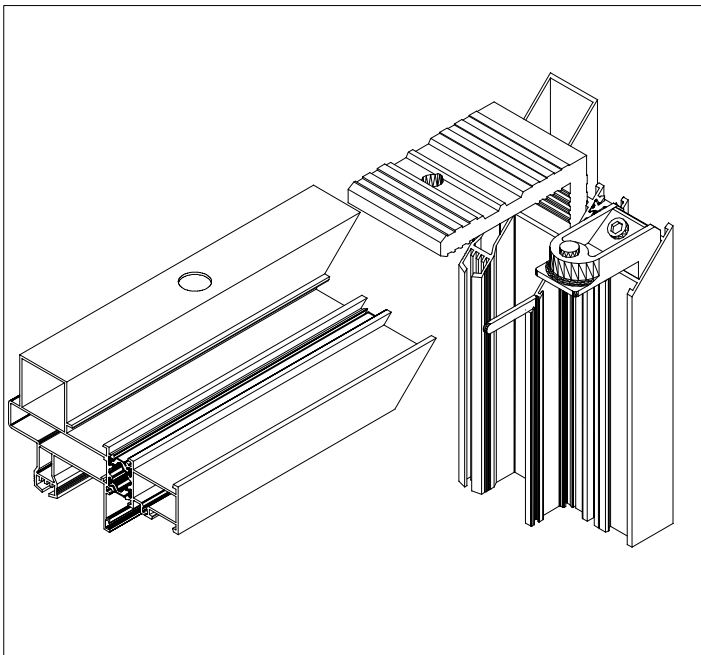
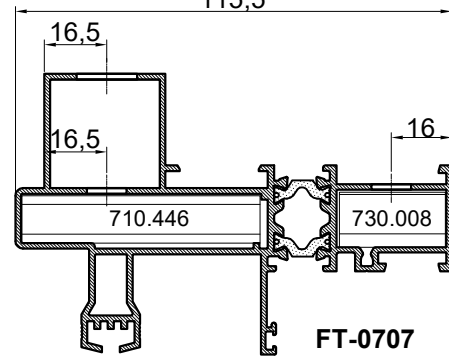
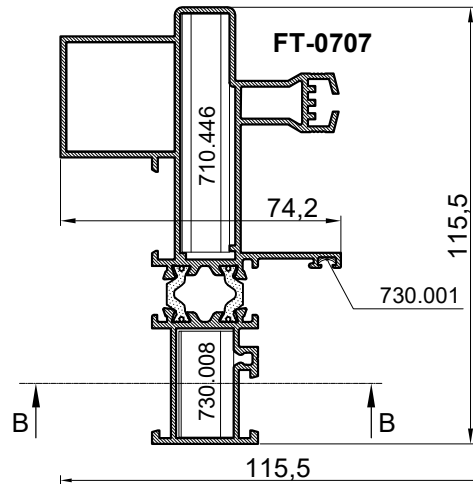
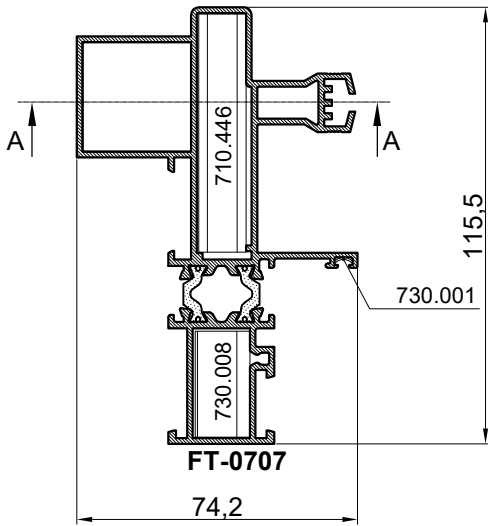
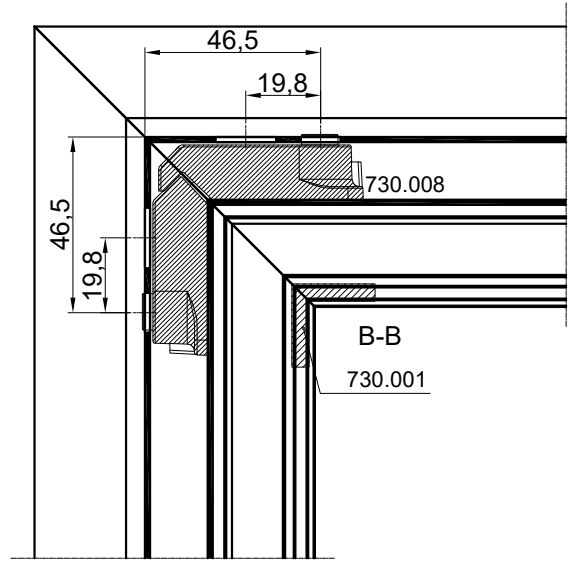
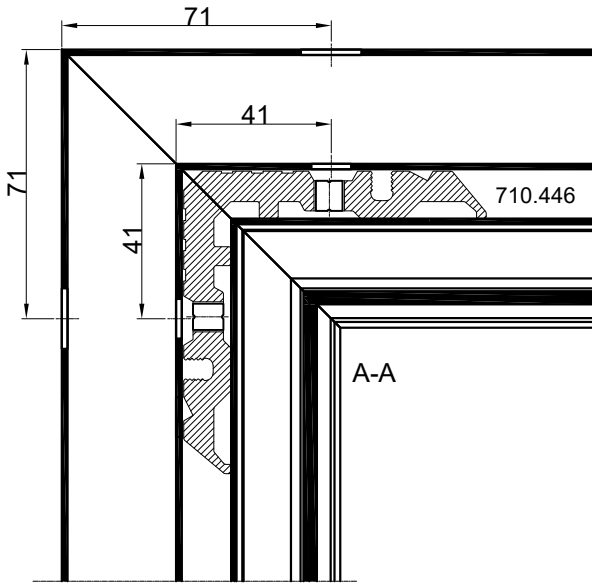

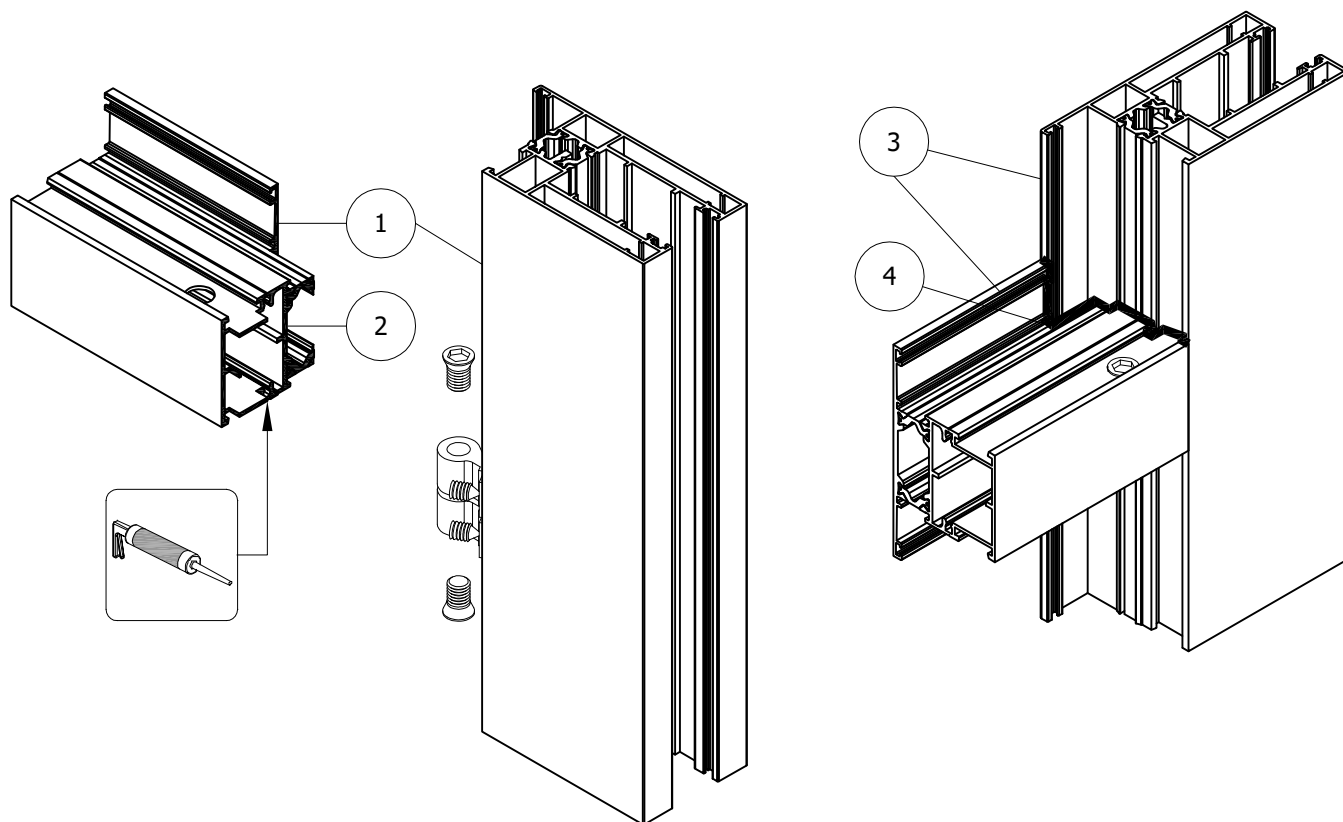

#### POSTUPAK SPAJANJA PROFILA :

1. Sve površine koje se spajaju-rezove očistiti i odmastiti odgovarajućim sredstvom /npr. "Henkel" - Teroson VR 20 ili Teroson FL+ /.
2. Premazati sve površine koje se spajaju ljepljivom za metal /npr. "Henkel" - Teroson MS 939 /.
3. Profile s veznicama izravnati i spojiti
4. Nakon spajanja profila, sve spojeve profila ispuniti ljepljivom za metal /npr. "Henkel" - Teroson MS 939 /.
5. Dio ljepljive koji iscure između rezova očistiti sredstvom za čišćenje i odmašćivanje /npr. "Henkel" - Teroson VR 20 ili Teroson FL+ /.

#### NAPOMENA:

Lijepljenjem rezova, kao i svih spojeva profila sa ljepljivima za metal, osigurava se potrebna zrako i vodonepropusnosti spoja kao i dodatna mehanička čvrstoća spoja.

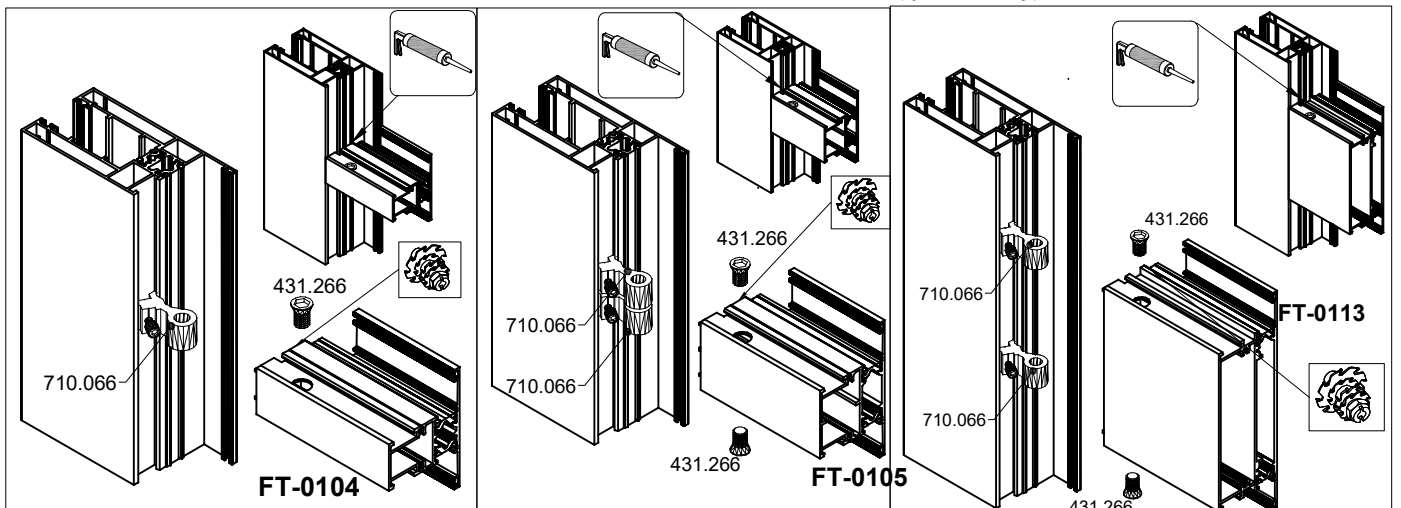
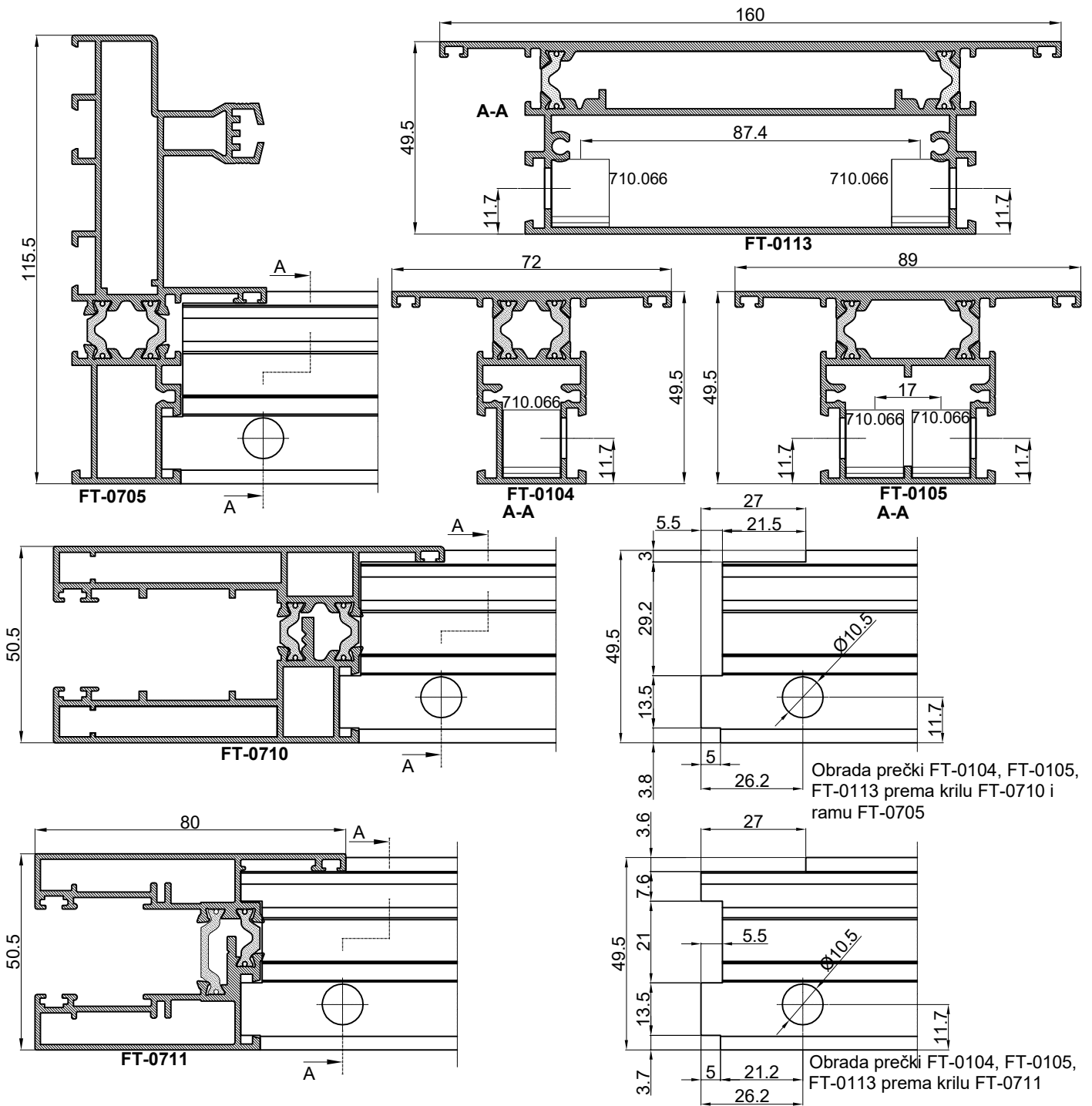

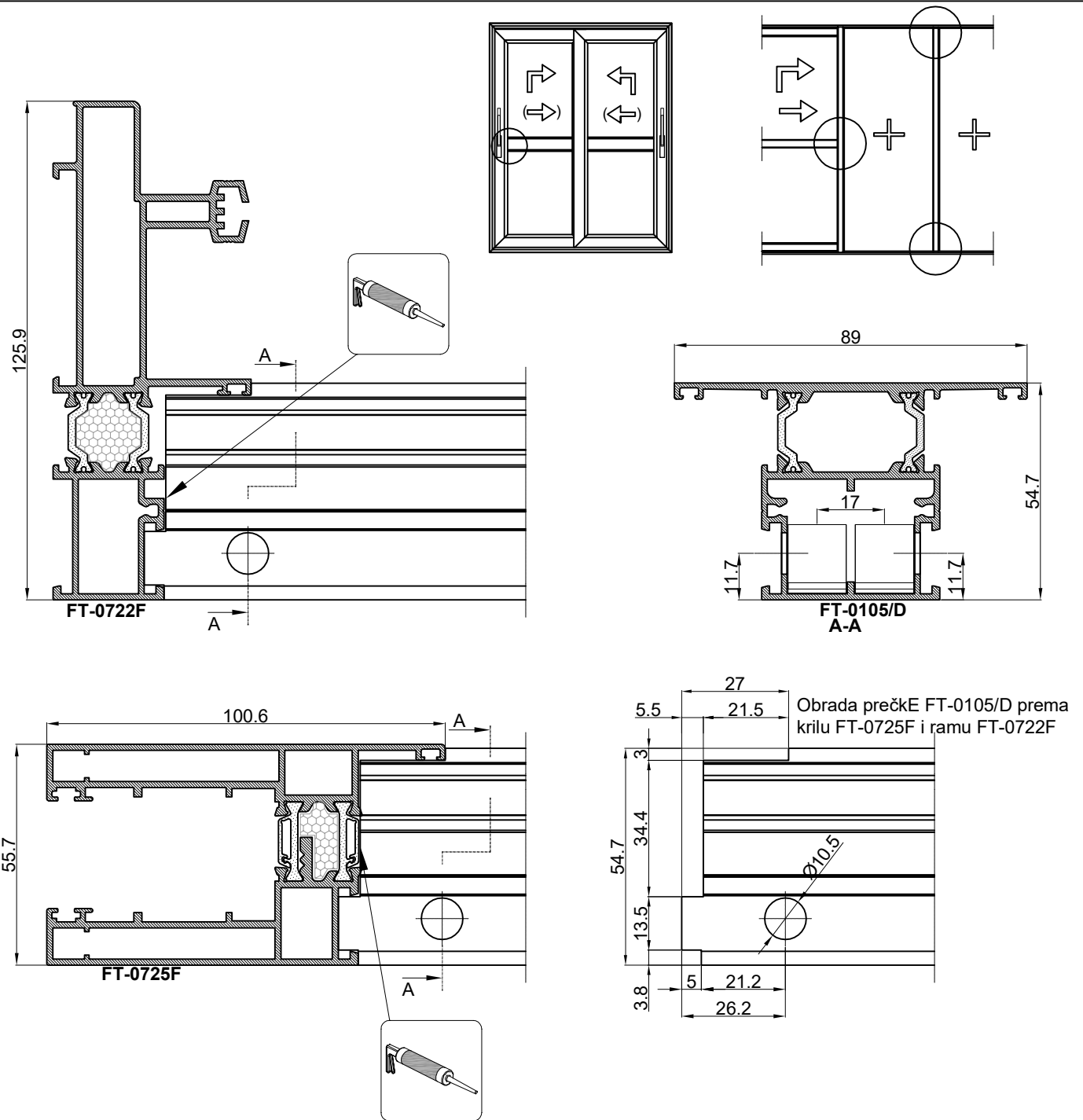

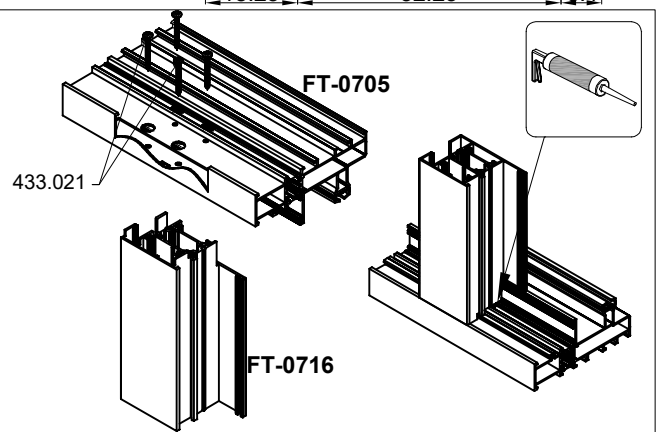
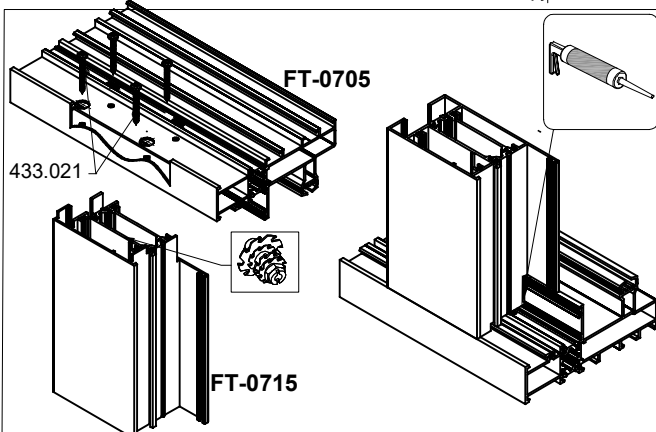
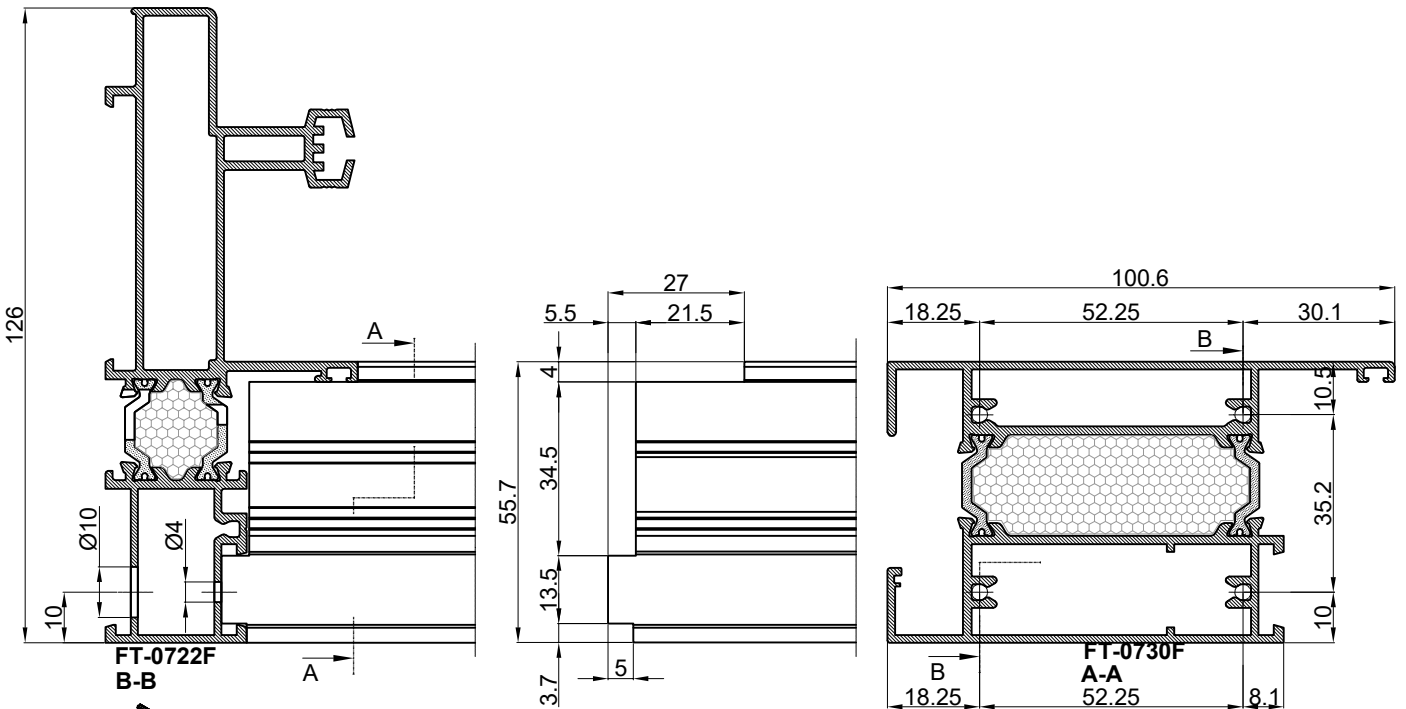
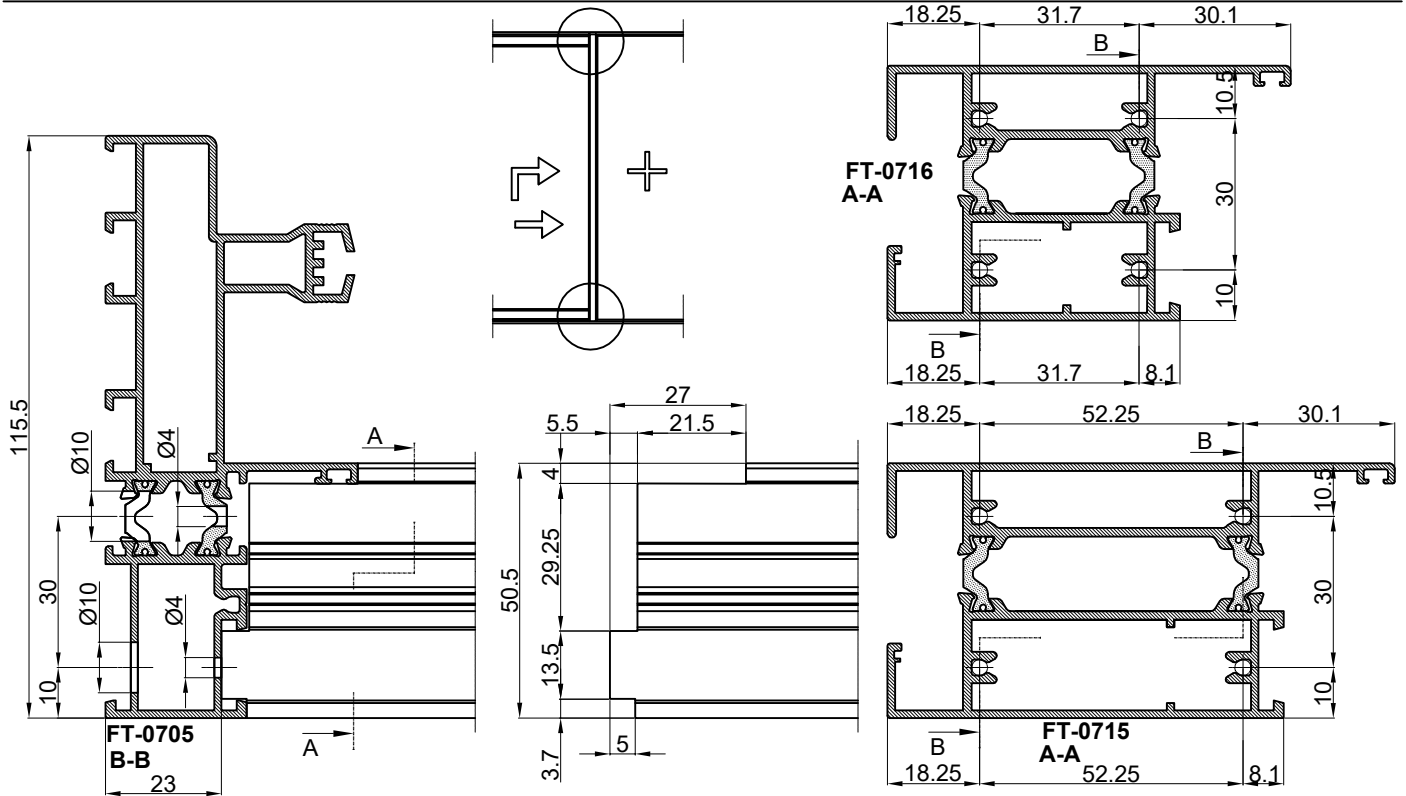

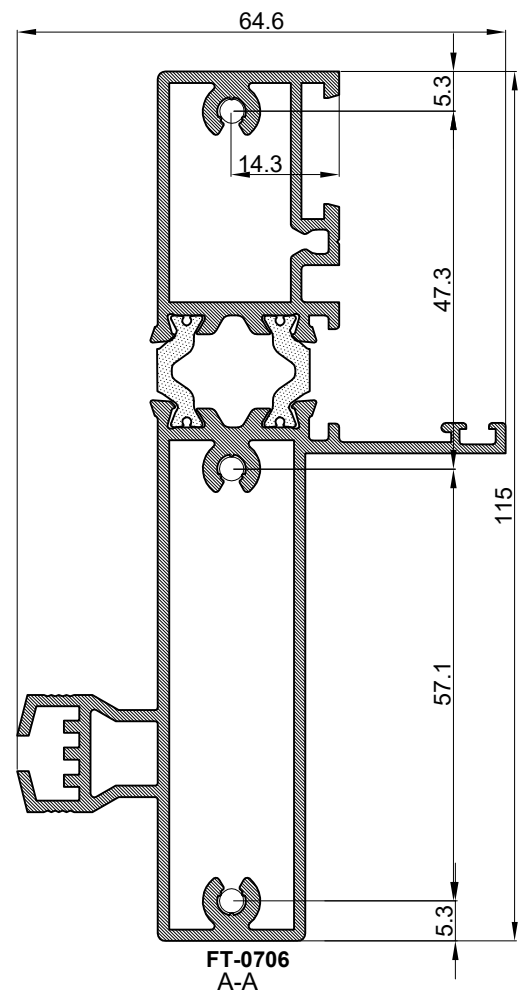
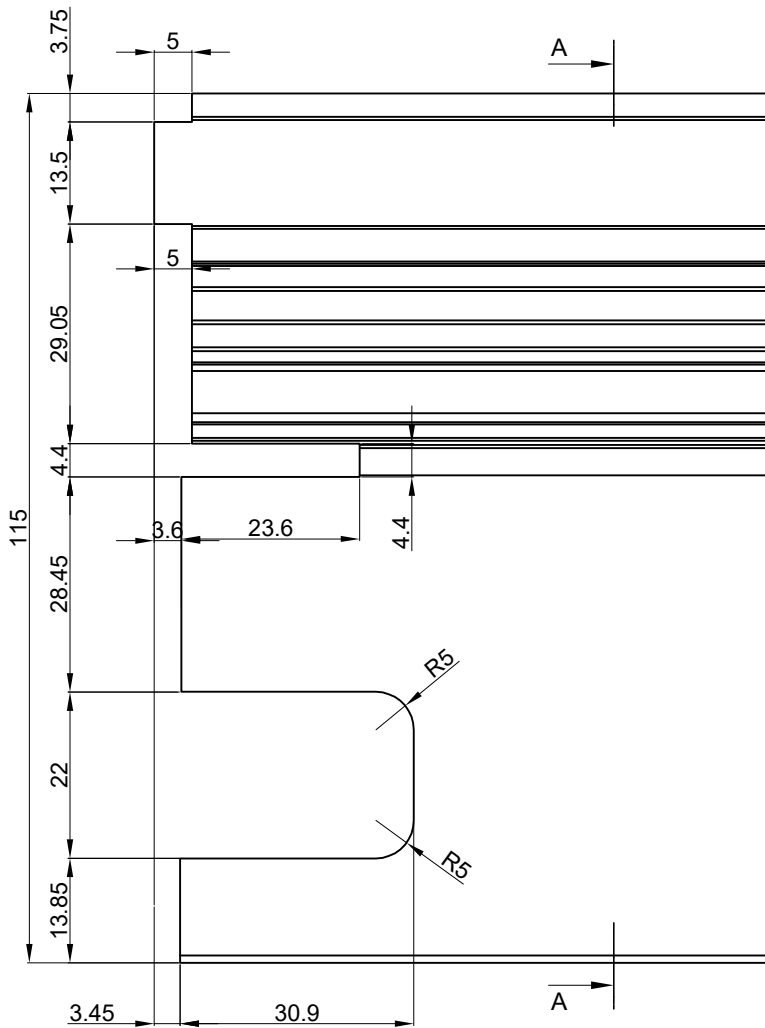
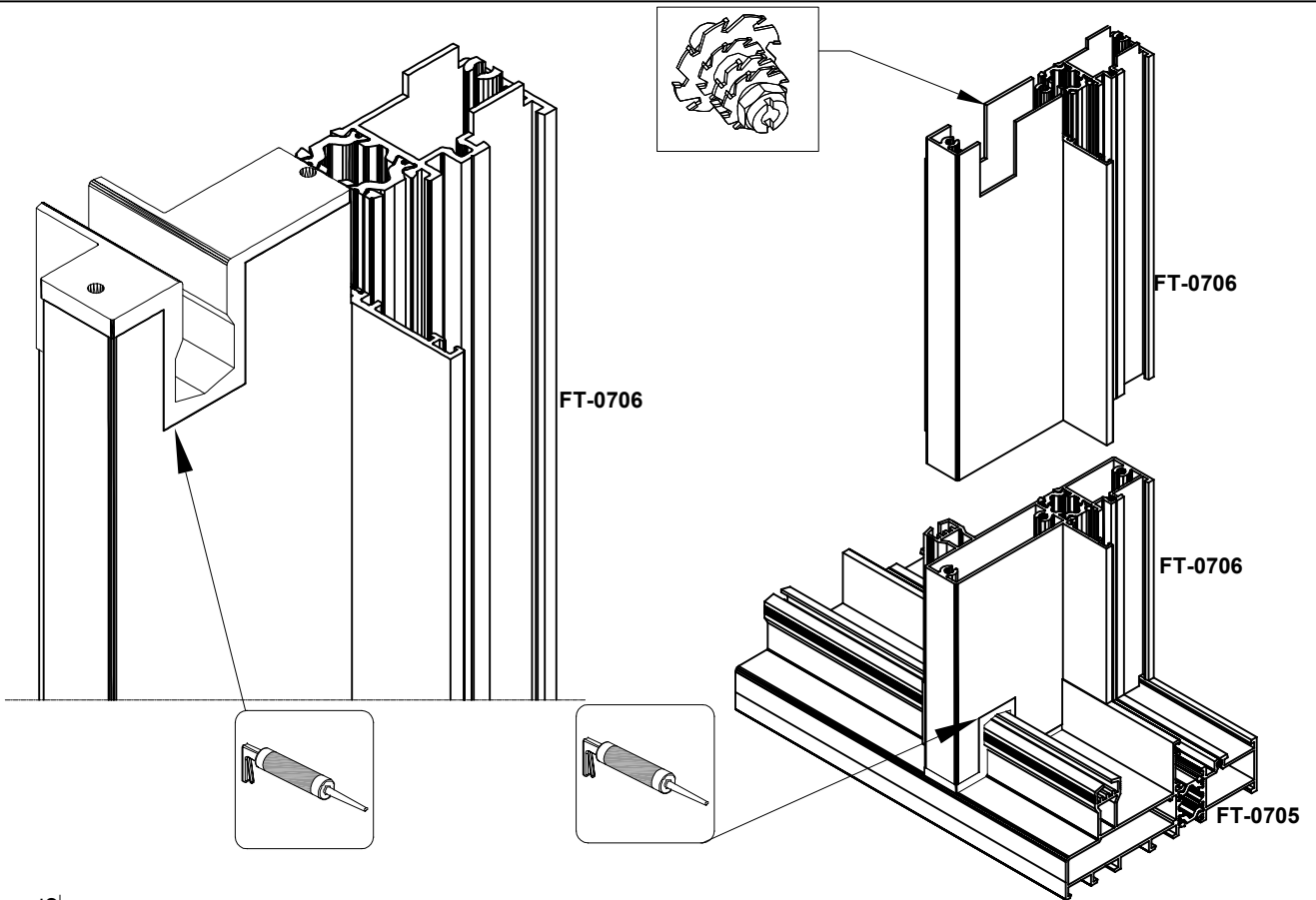



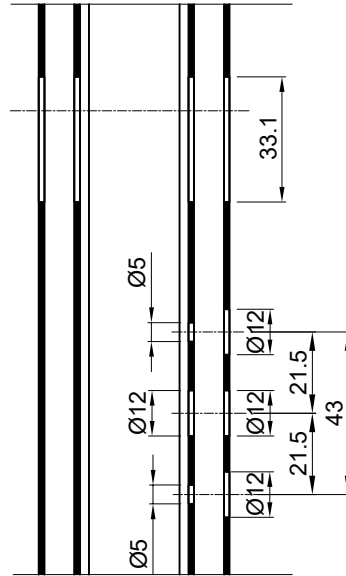
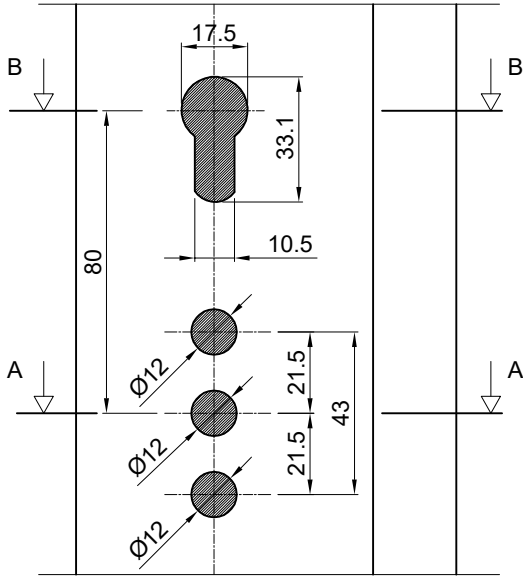

OBRADA PROFILA FT-0710  
ZA RUCKE NOTTER (KLIZNO)

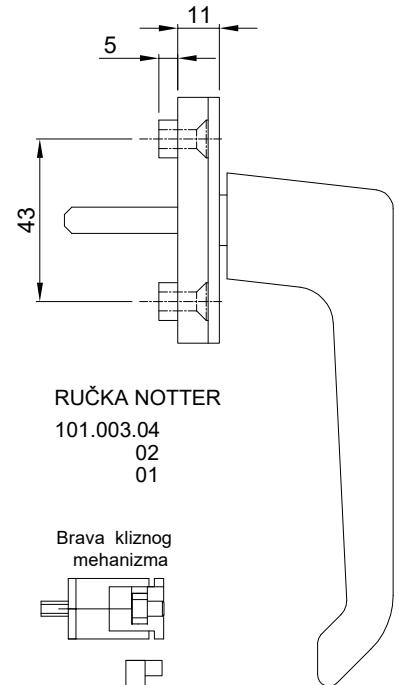

RUČKA NOTTER  
101.003.04  
02  
01

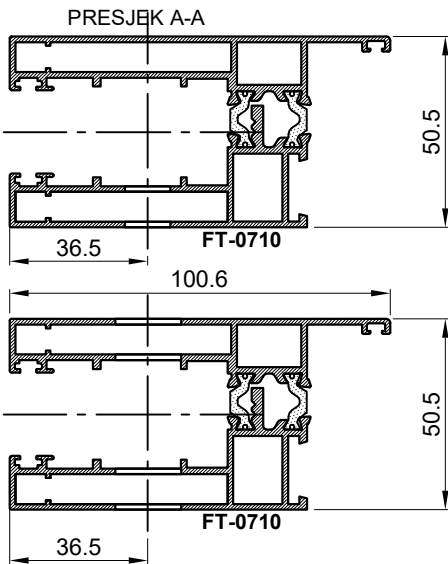

PRESJEK B-B

374.027

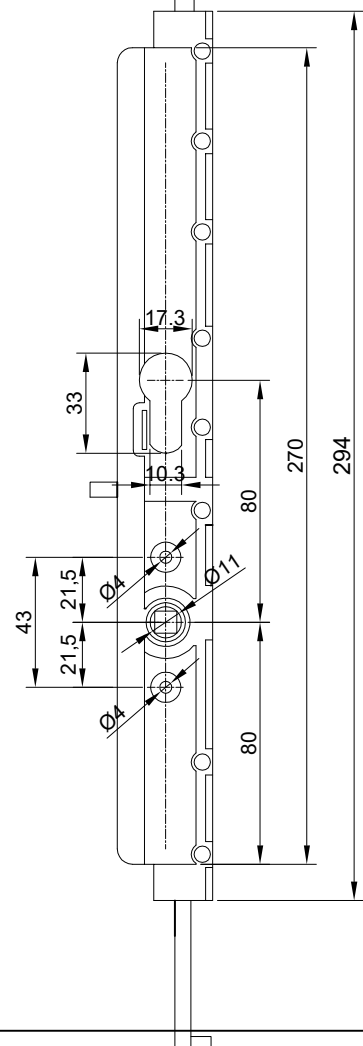
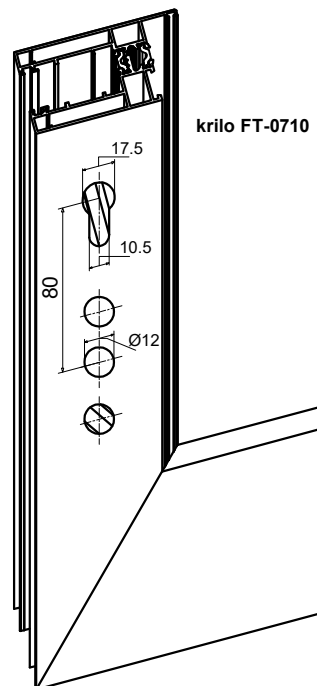
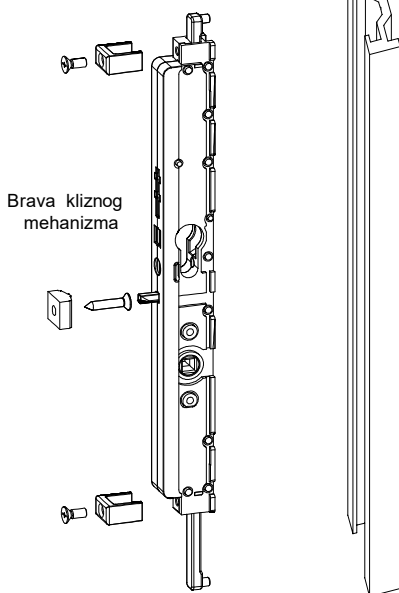

OBRADA PROFILA FT-0710 I FT-0725F ZA RUČKU 108.008, Hautau

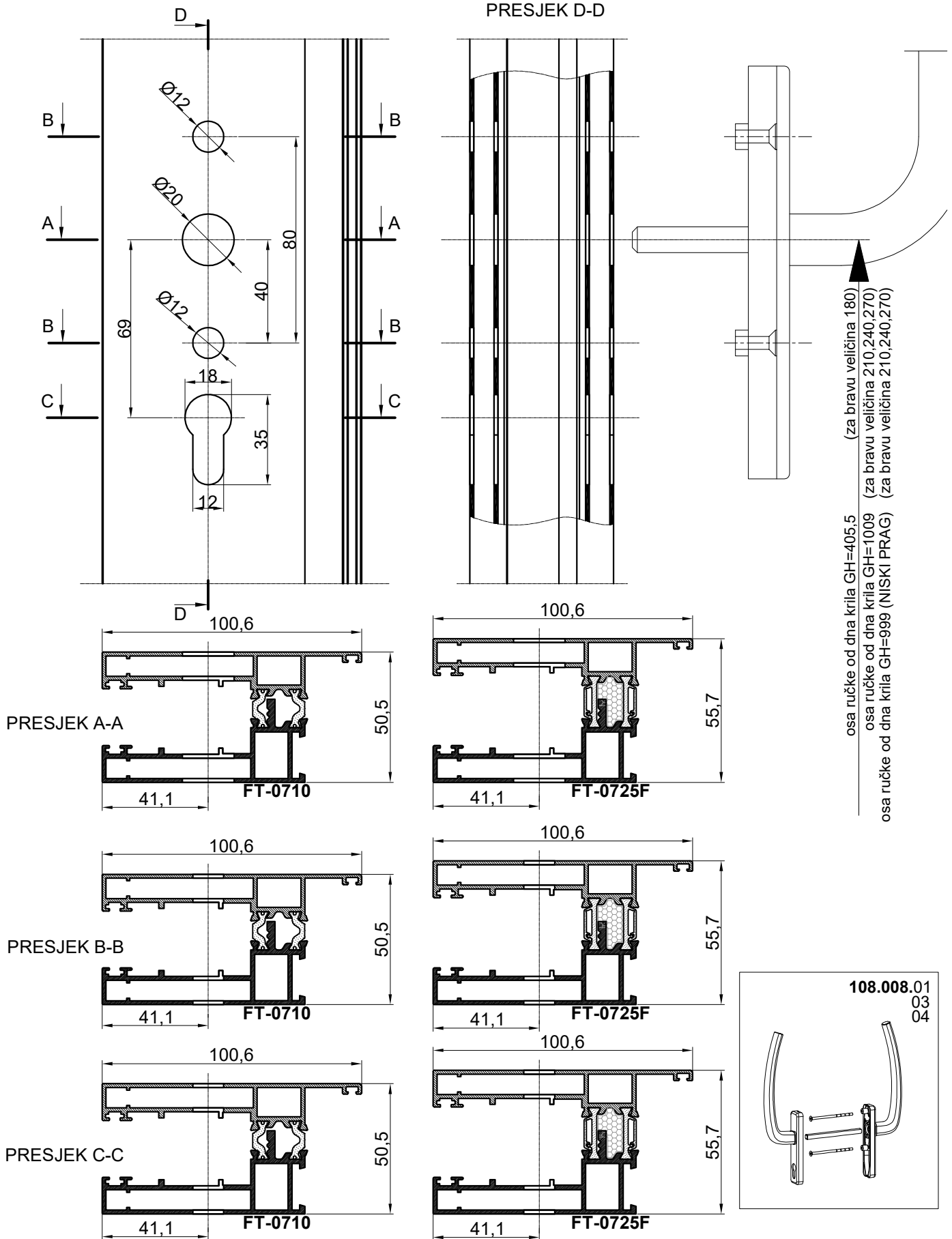

- za bravu Atrium Alu-HS 200 (Hautau)

OBRADA PROFILA FT-0710 I FT-0725F ZA RUČKU 108.001, Hautau

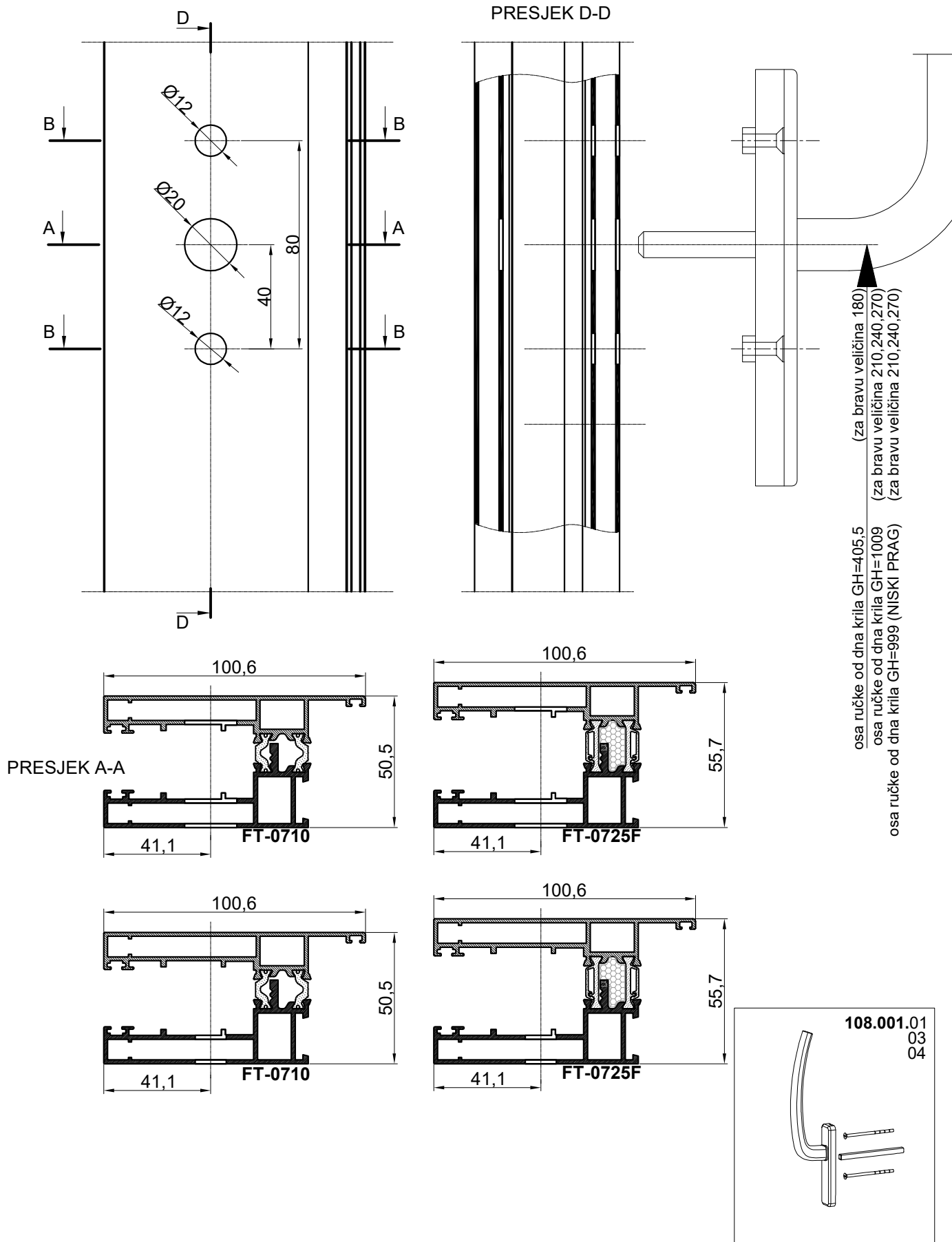

- za bravu Atrium Alu-HS 200 (Hautau)

OBRADA PROFILA FT-0710 I FT-0725F ZA RUČKU 108.007, Hautau

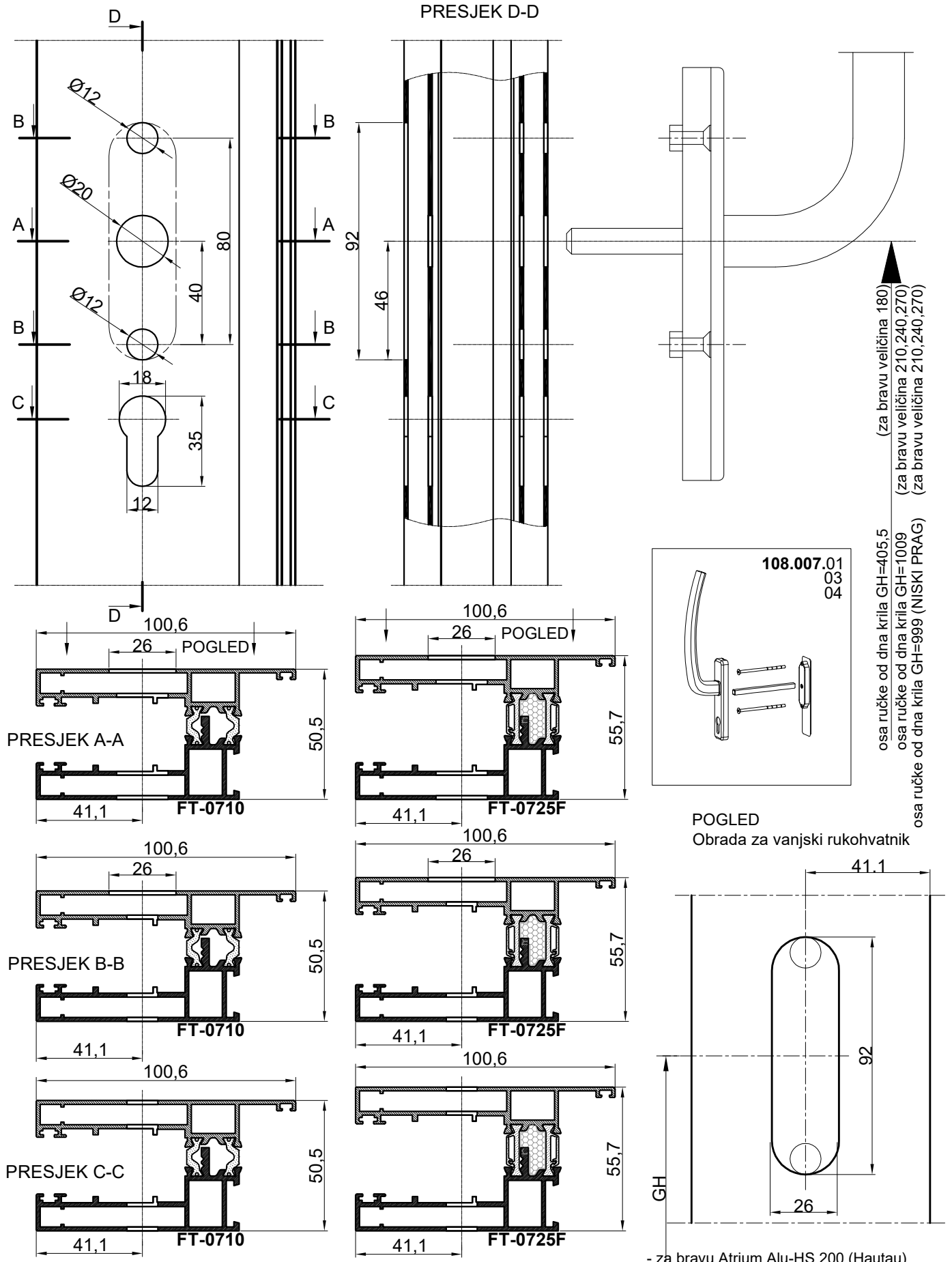

(za bravu veličina 180)  
(za bravu veličina 210,240,270)  
(za bravu veličina 210,240,270)

- za bravu Atrium Alu-HS 200 (Hautau)

OBRADA PROFILA FT-0710 I FT-0725F ZA RUČKU 108.006, Hautau

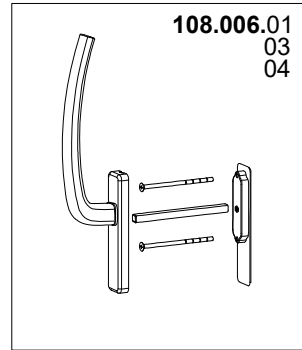
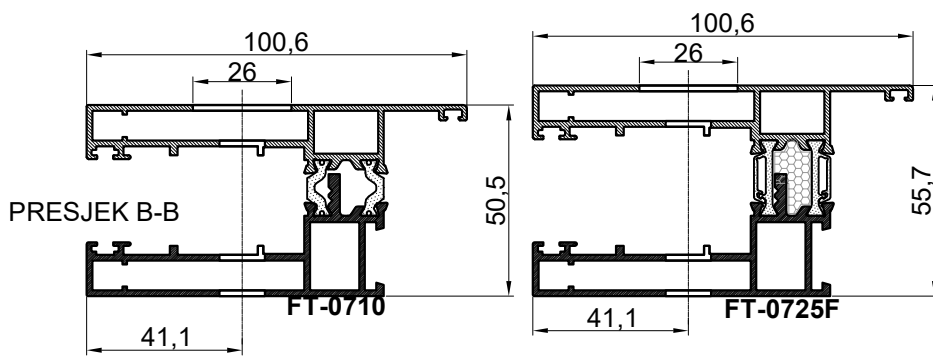
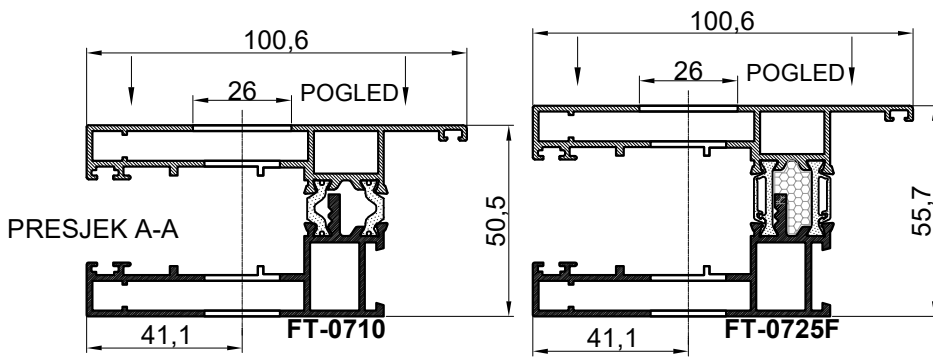
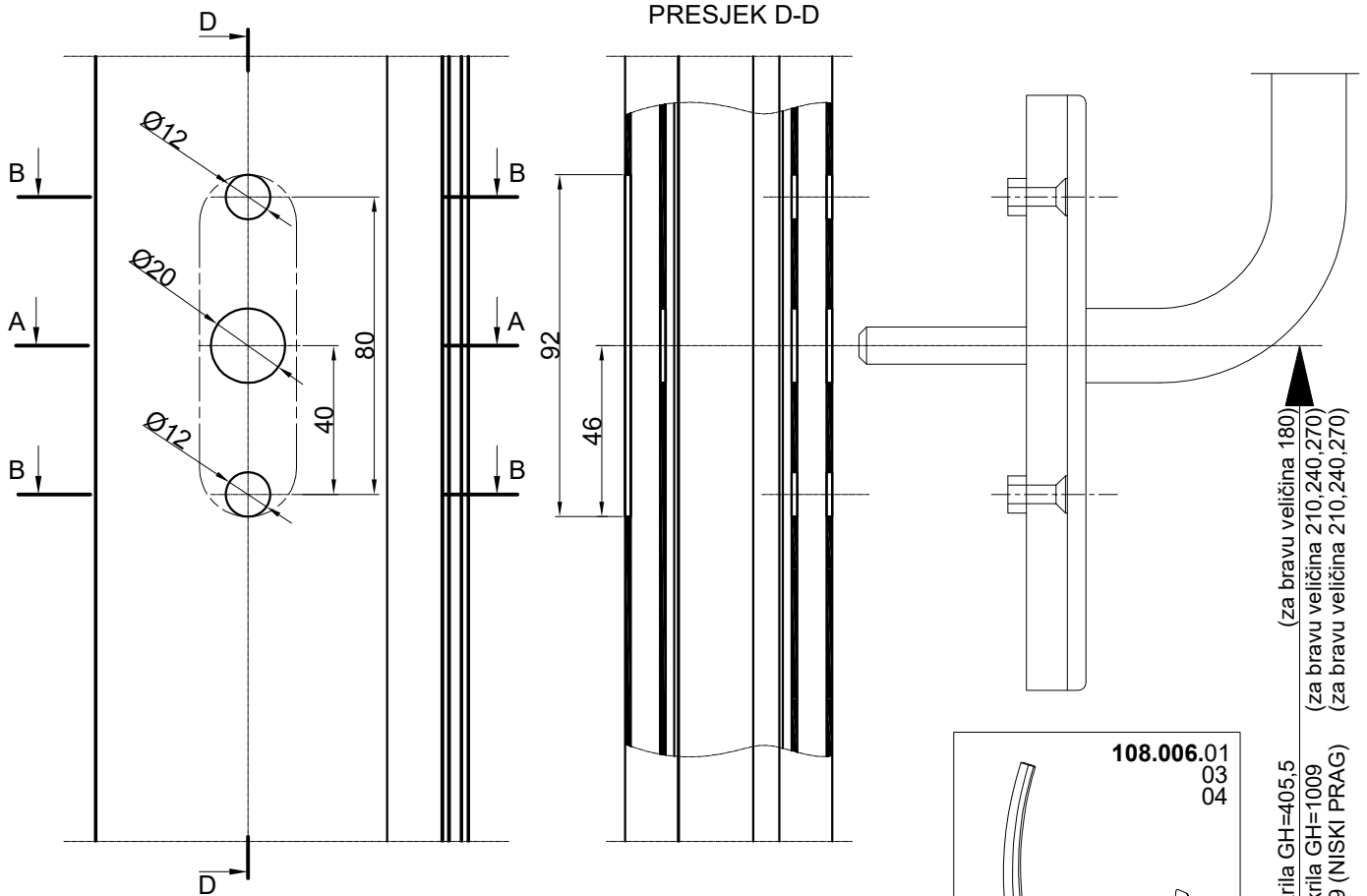

POGLED  
Obrada za vanjski rukohvatnik

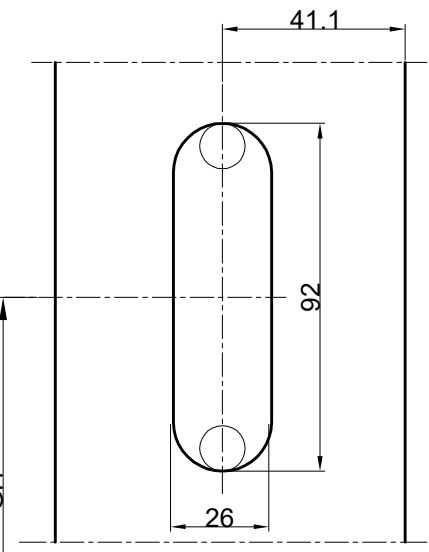

- za bravu Atrium Alu-HS 200 (Hautau)

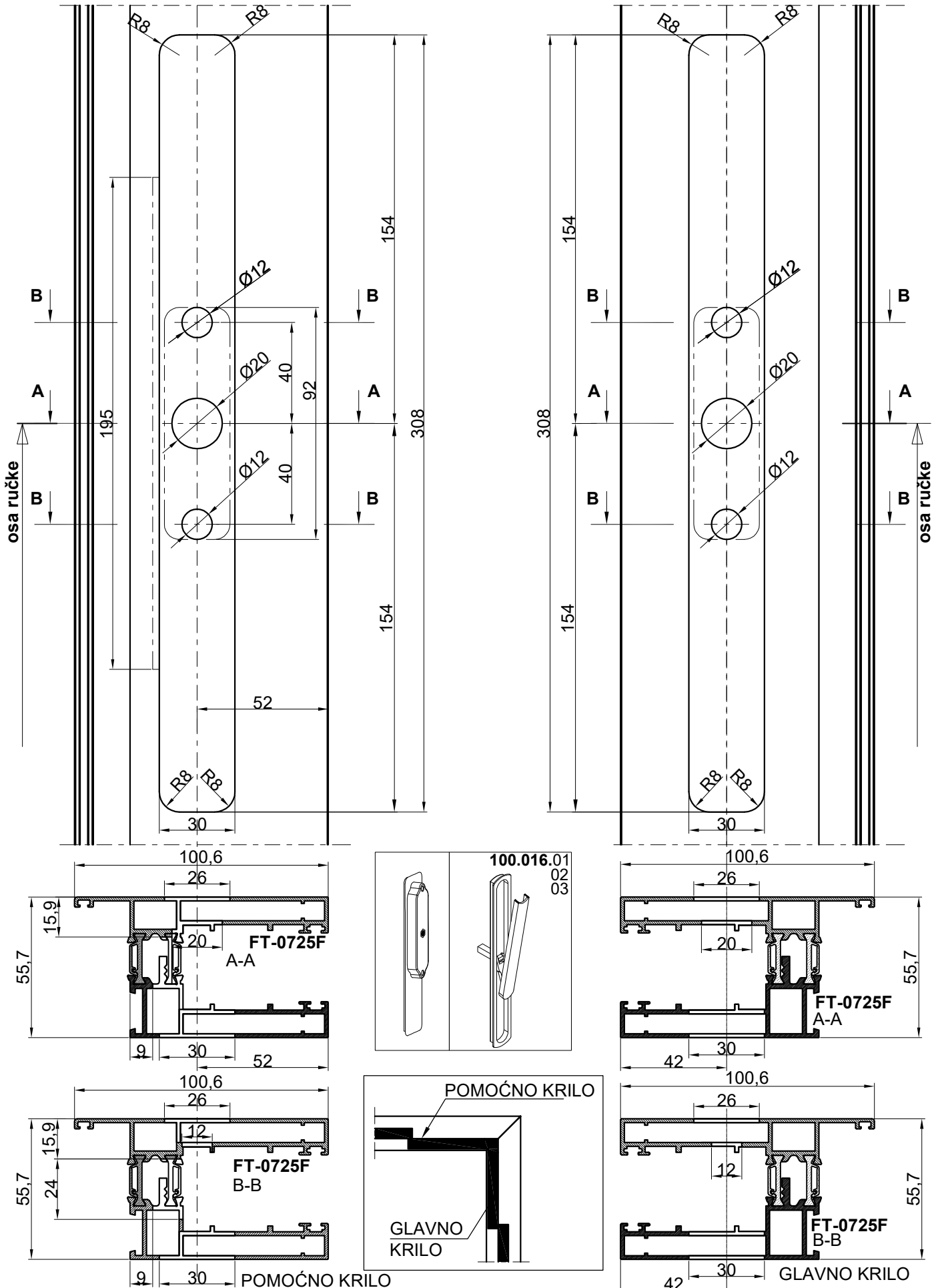

Obrada al. profila **F-1529** i pvc profila **374.075** i **374.088**  
(za profil krila FT-0710 i FT-0711)

mjera pilanja  $H(F-1529)=Hkrila$

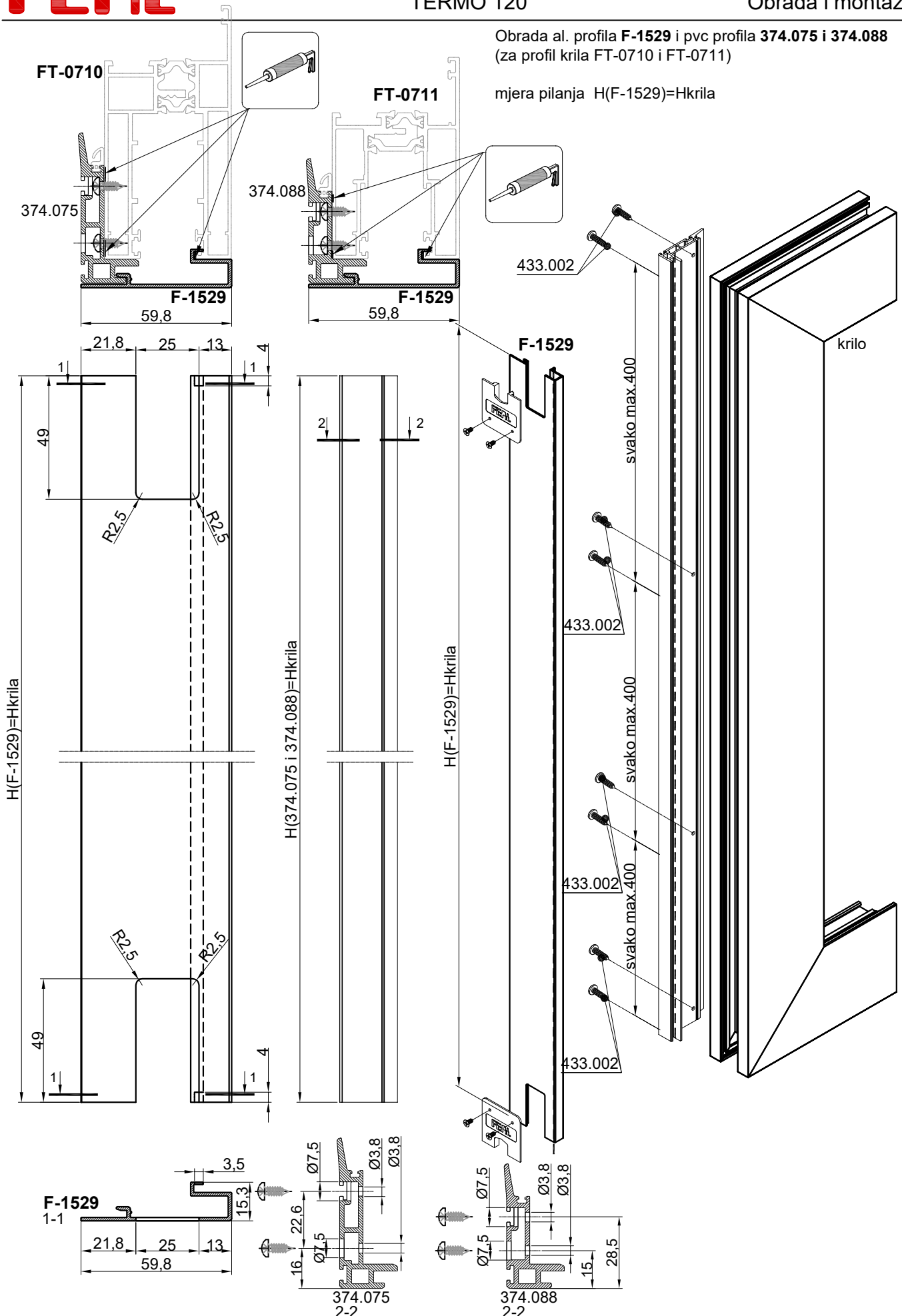

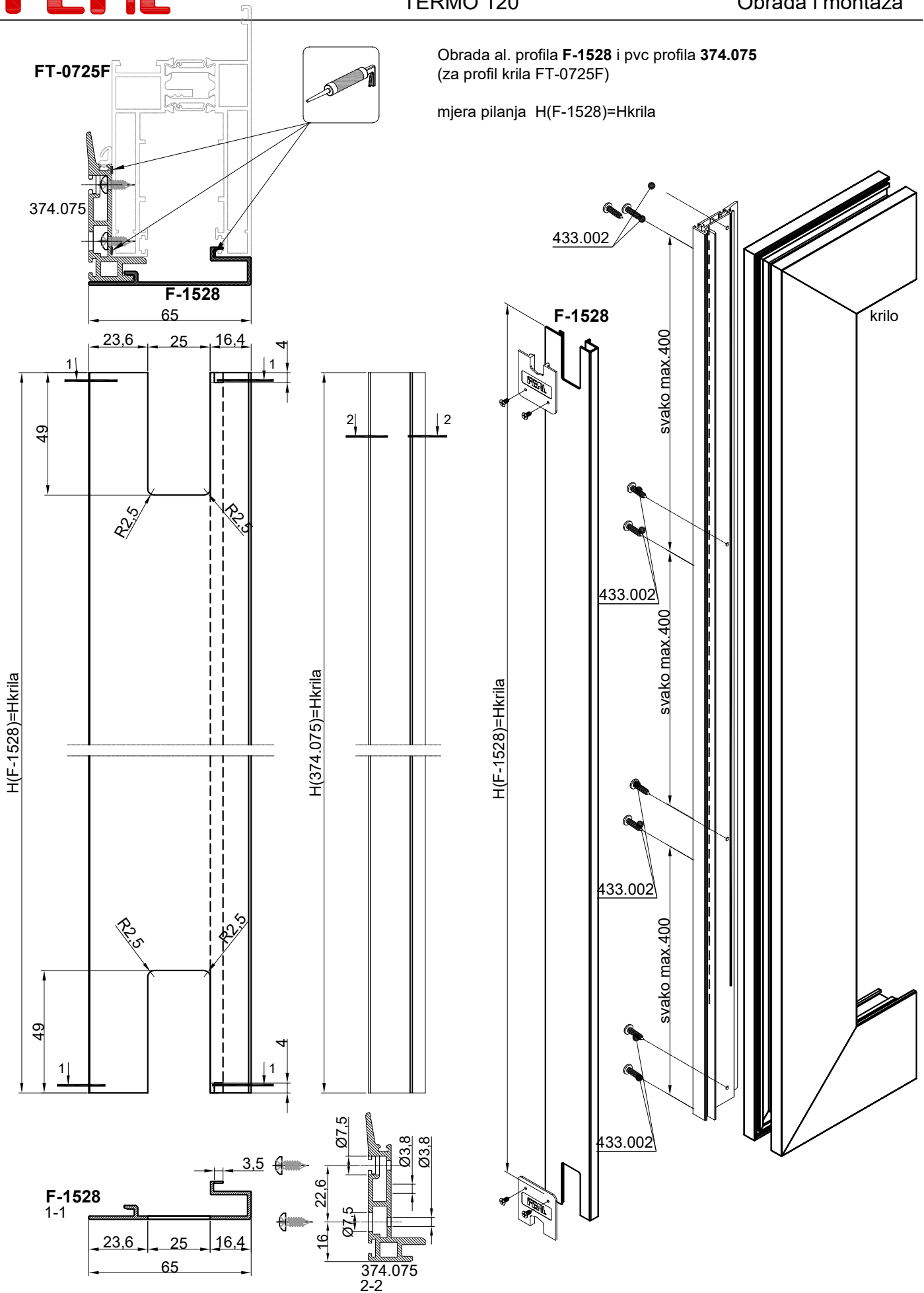

Obrada al. profila **F-1528 (ZA NISKI PRAG)** i pvc profila **374.075**  
(za profil krila FT-0725F)

mjera pilanja  $H(F-1528)=Hkrila$

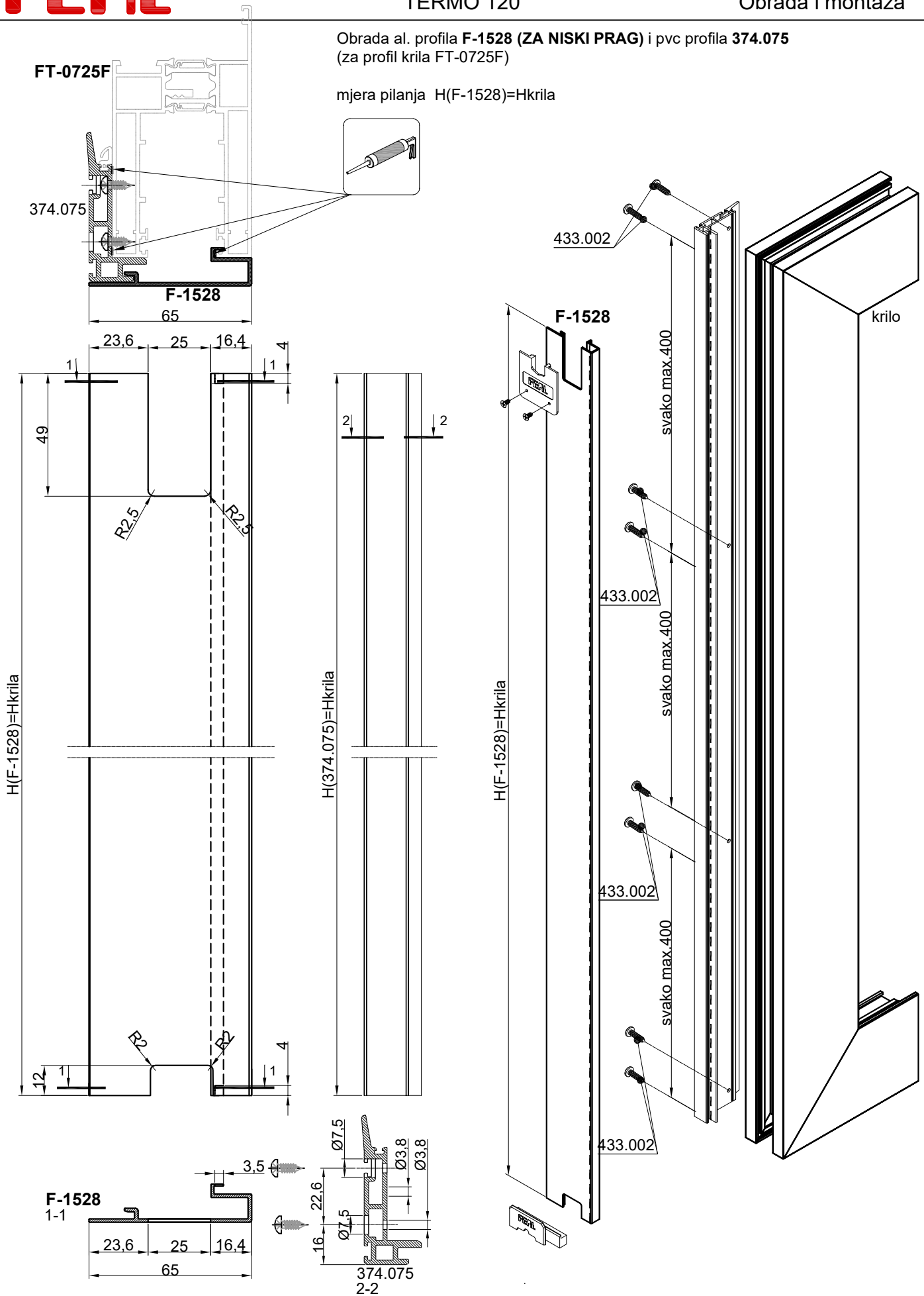

Obrada al. profila F-1529 i pvc profila 374.075 i 374.088 (za profil prečke FT-0715 i FT-0716)

mjera pilanja H(F-1529)=MH-56

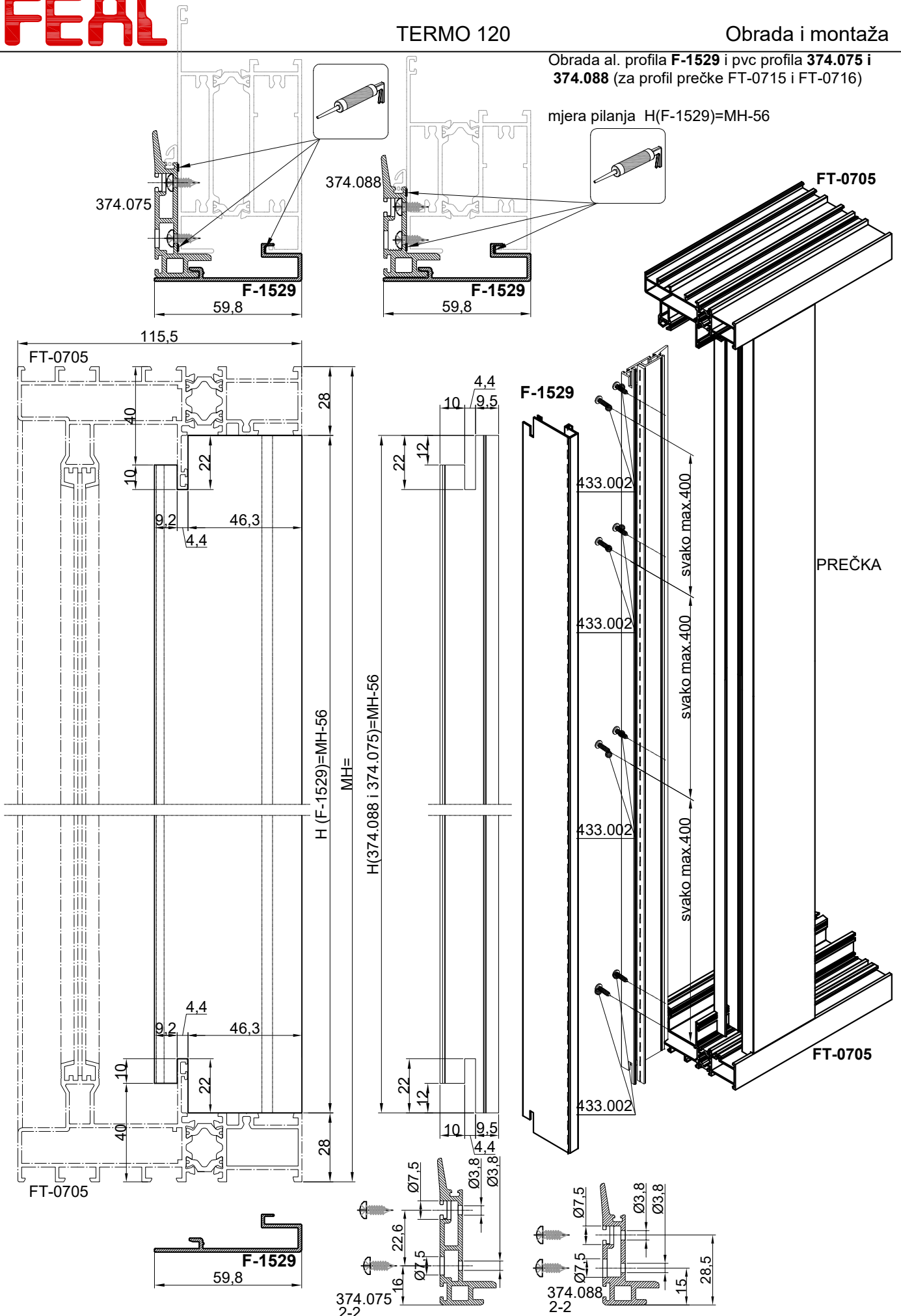

Obrada al. profila **F-1528** i pvc profila **374.075**  
(za profil prečke **FT-0730F**)

mjera pilanja  $H(F-1528)=MH-56$

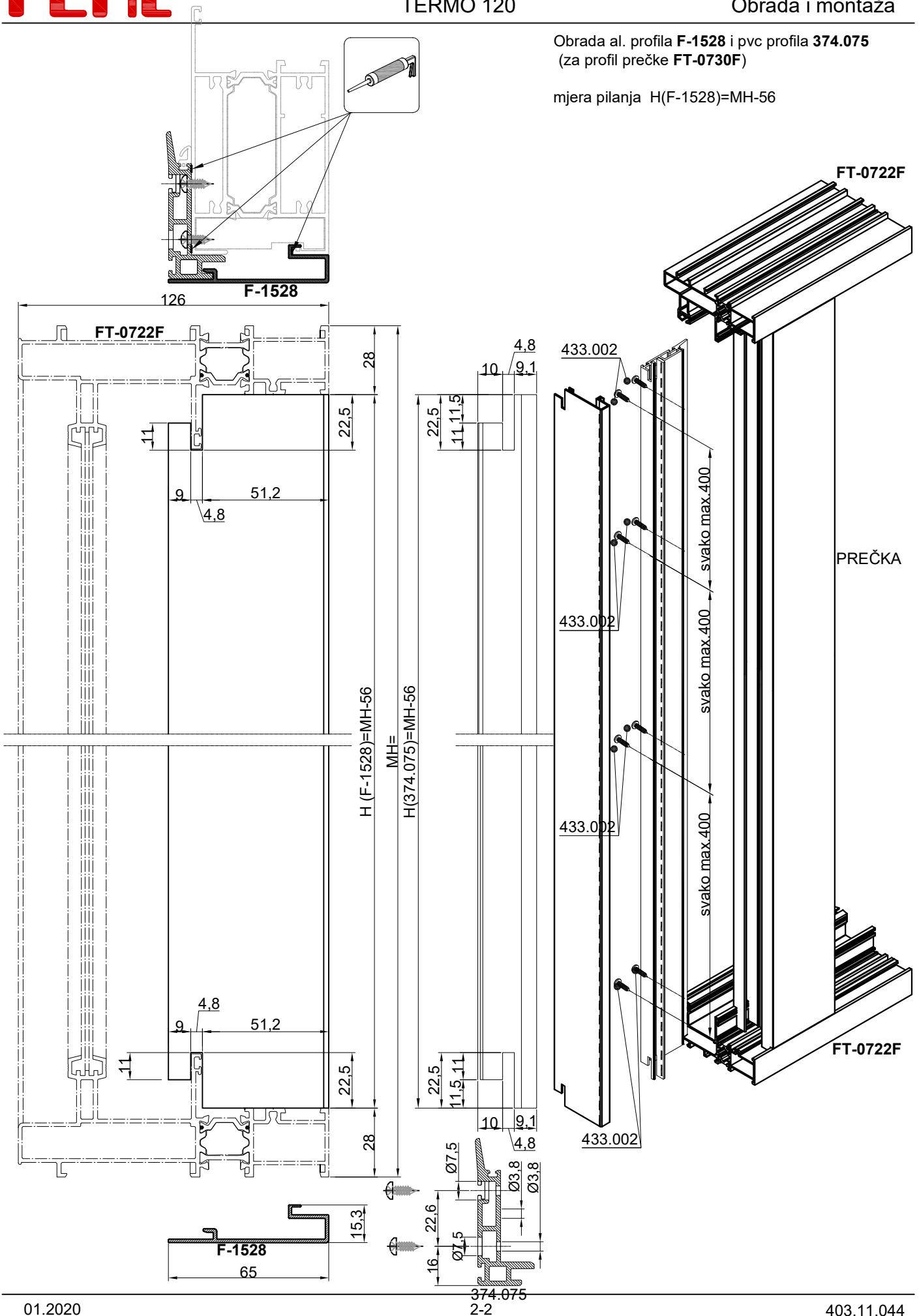

Obrada al. profila **F-1528** i pvc profila **374.075**  
(za profil prečke **FT-0730F**) -NISKI PRAG

mjera pilanja  $H(F-1528)=MH-40.5$

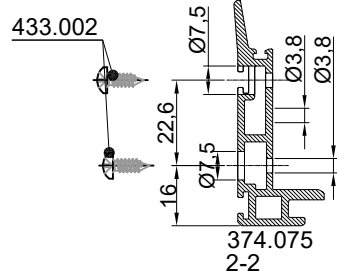
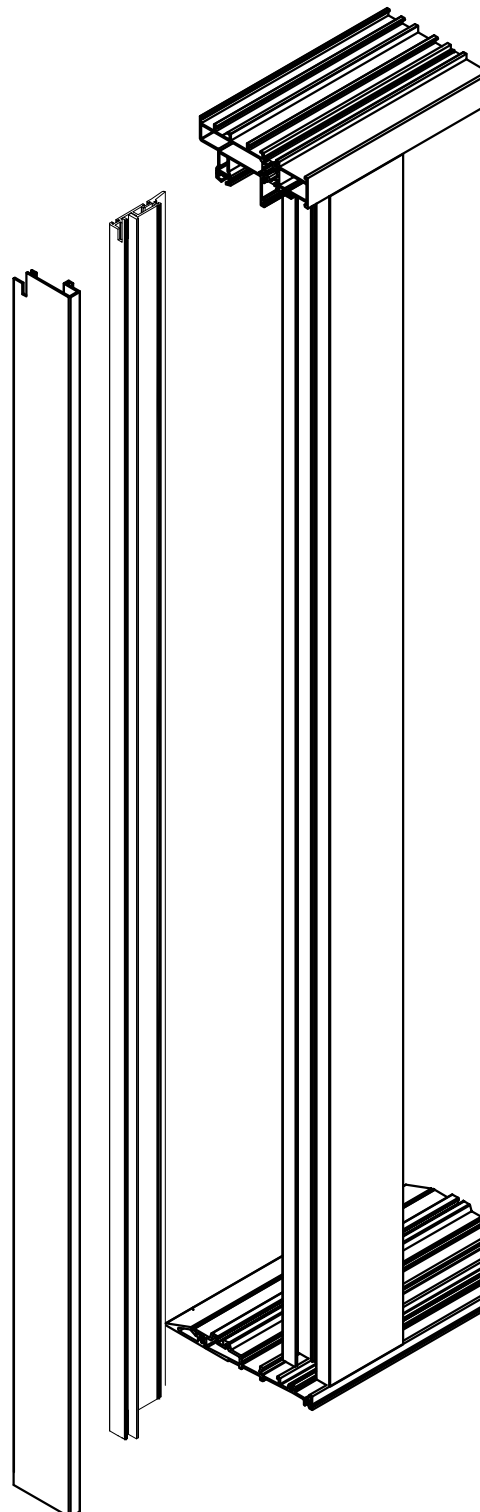
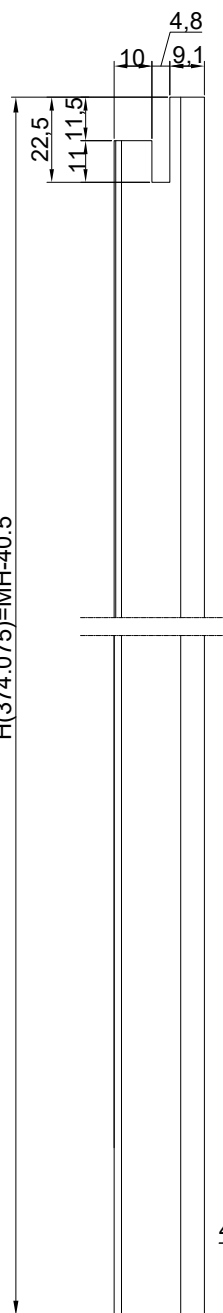
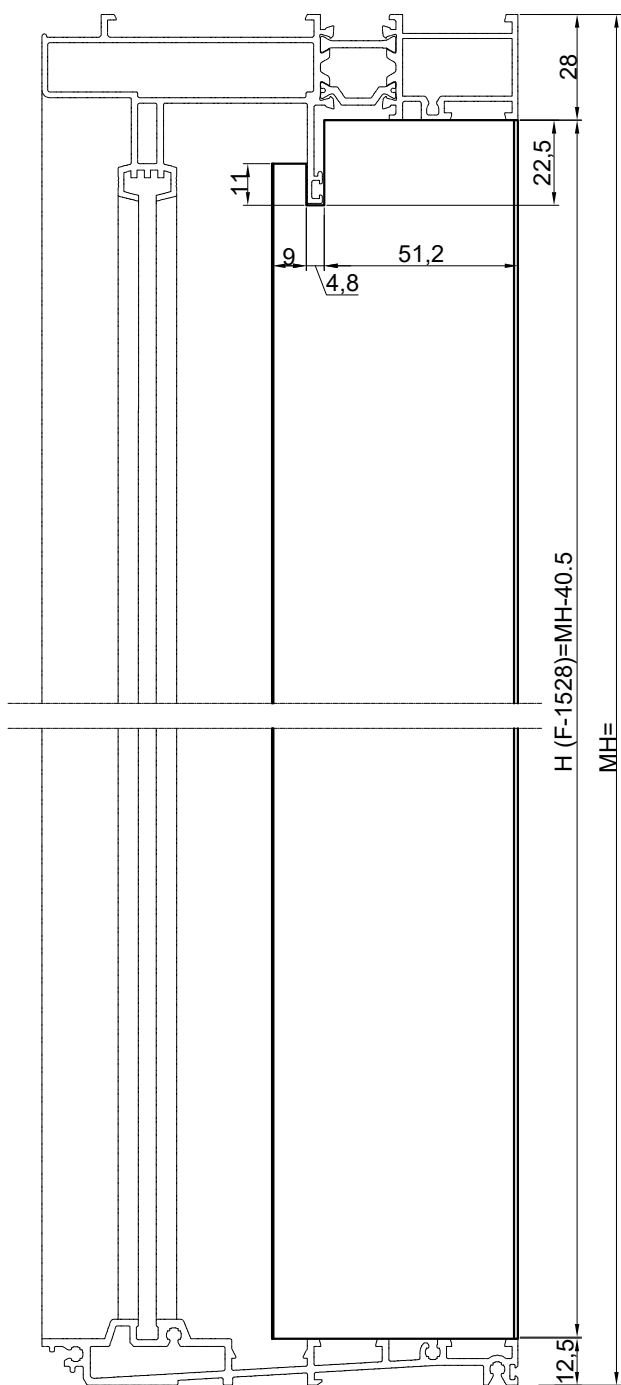
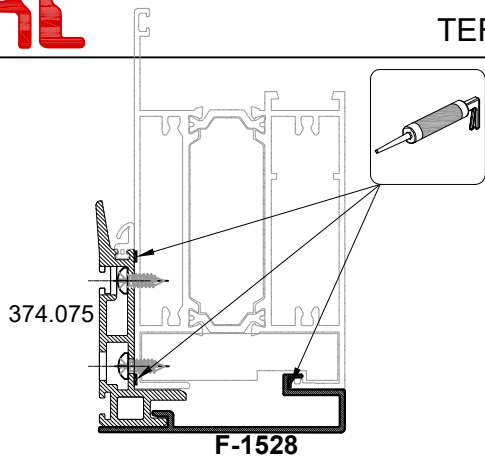

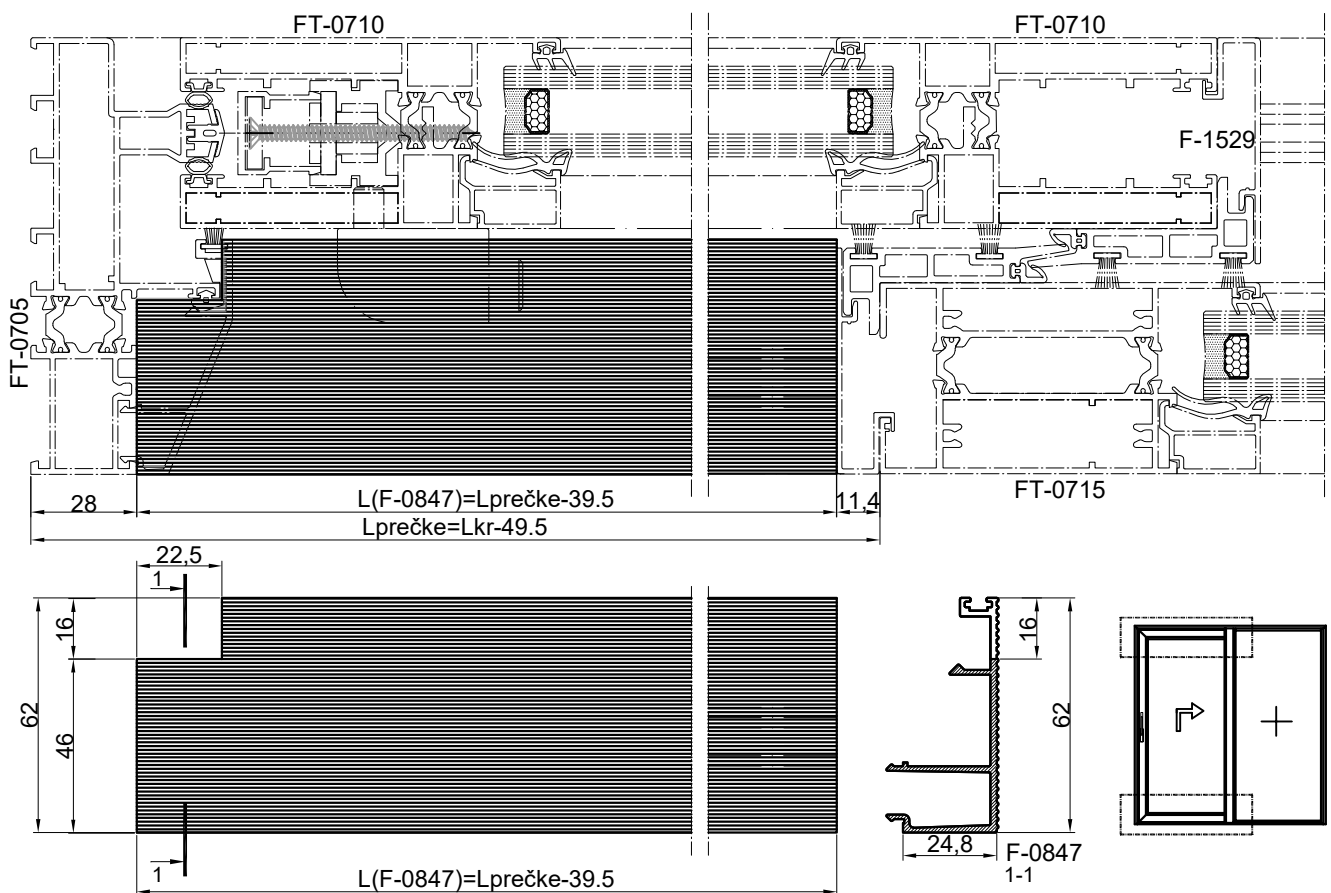
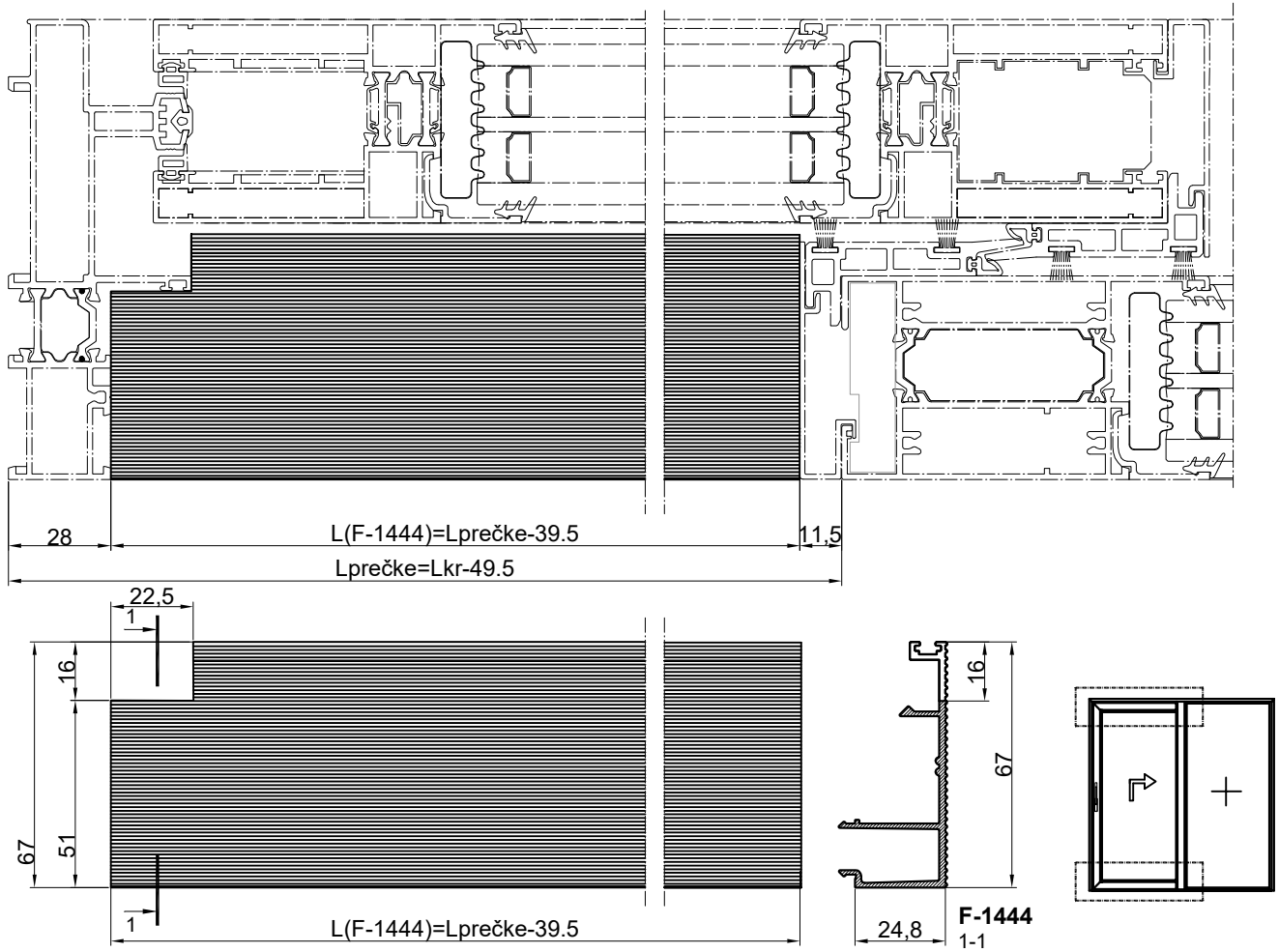

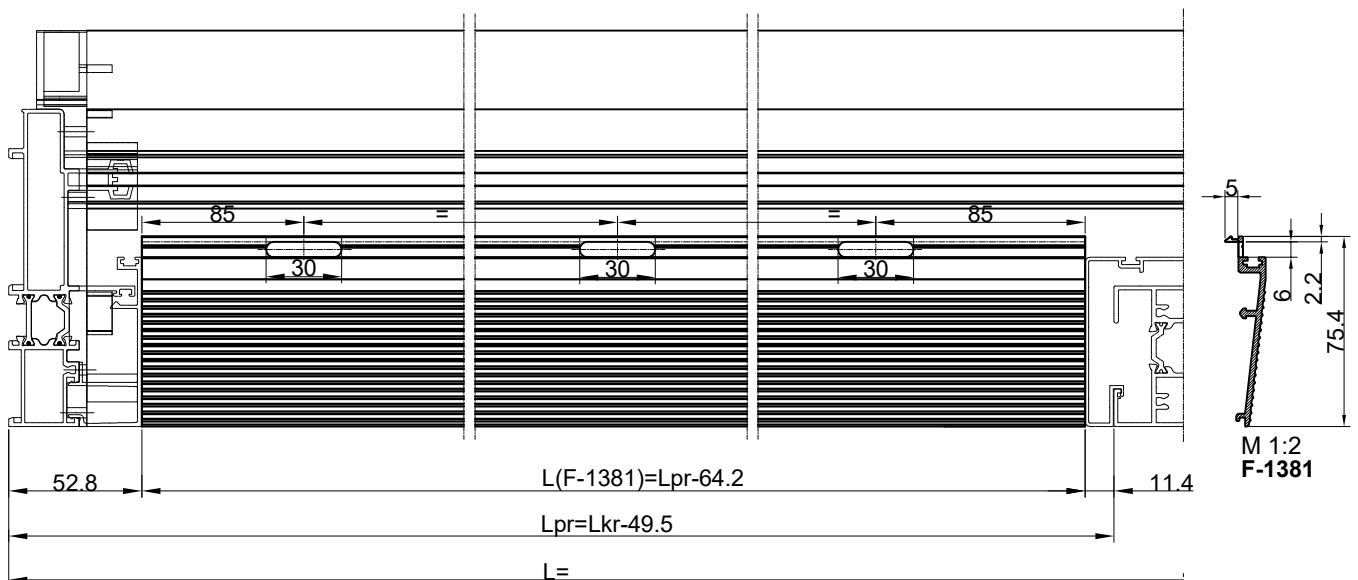
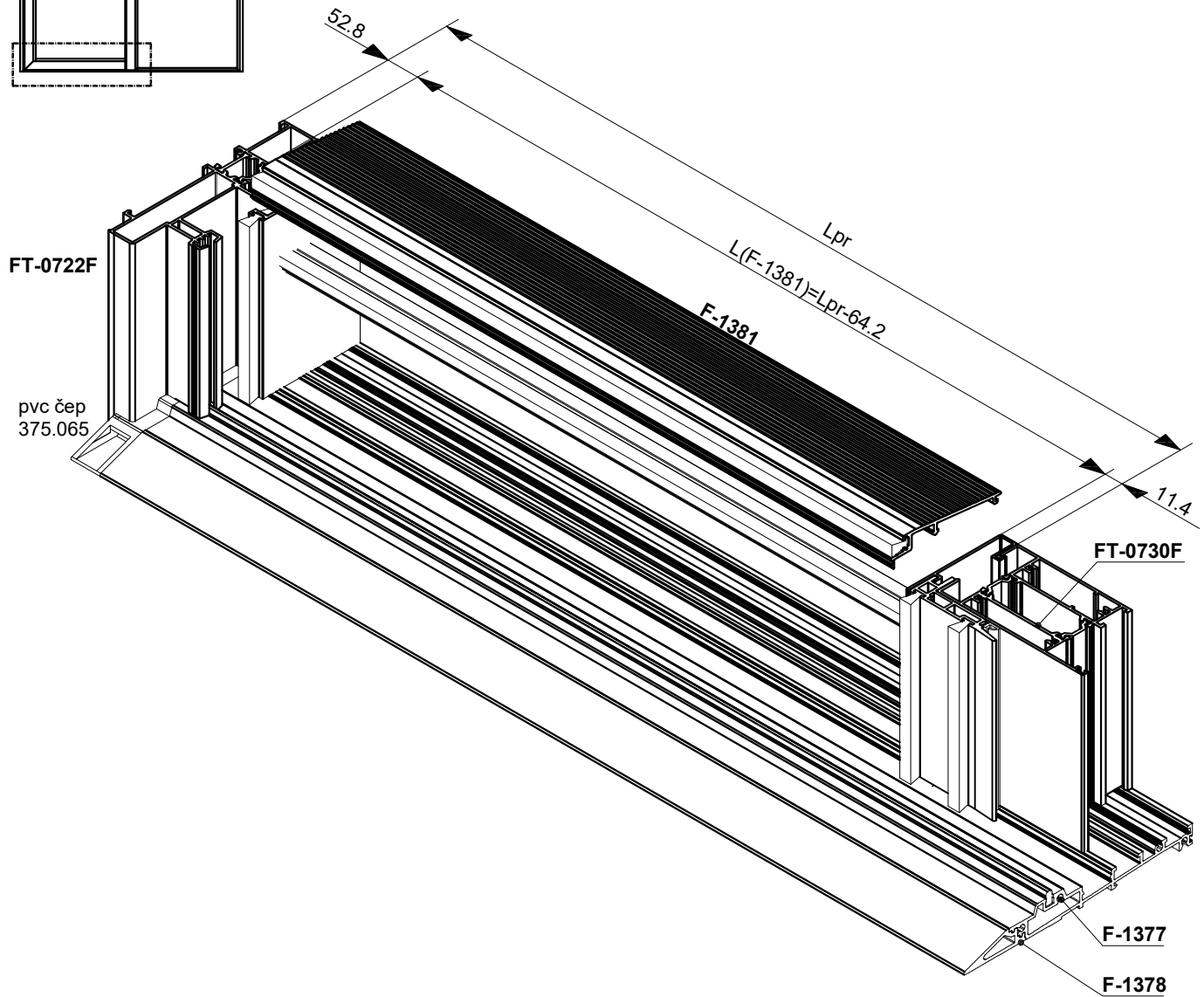
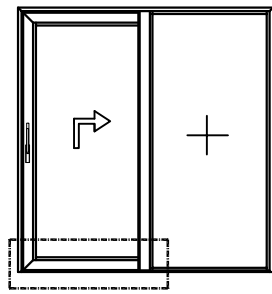

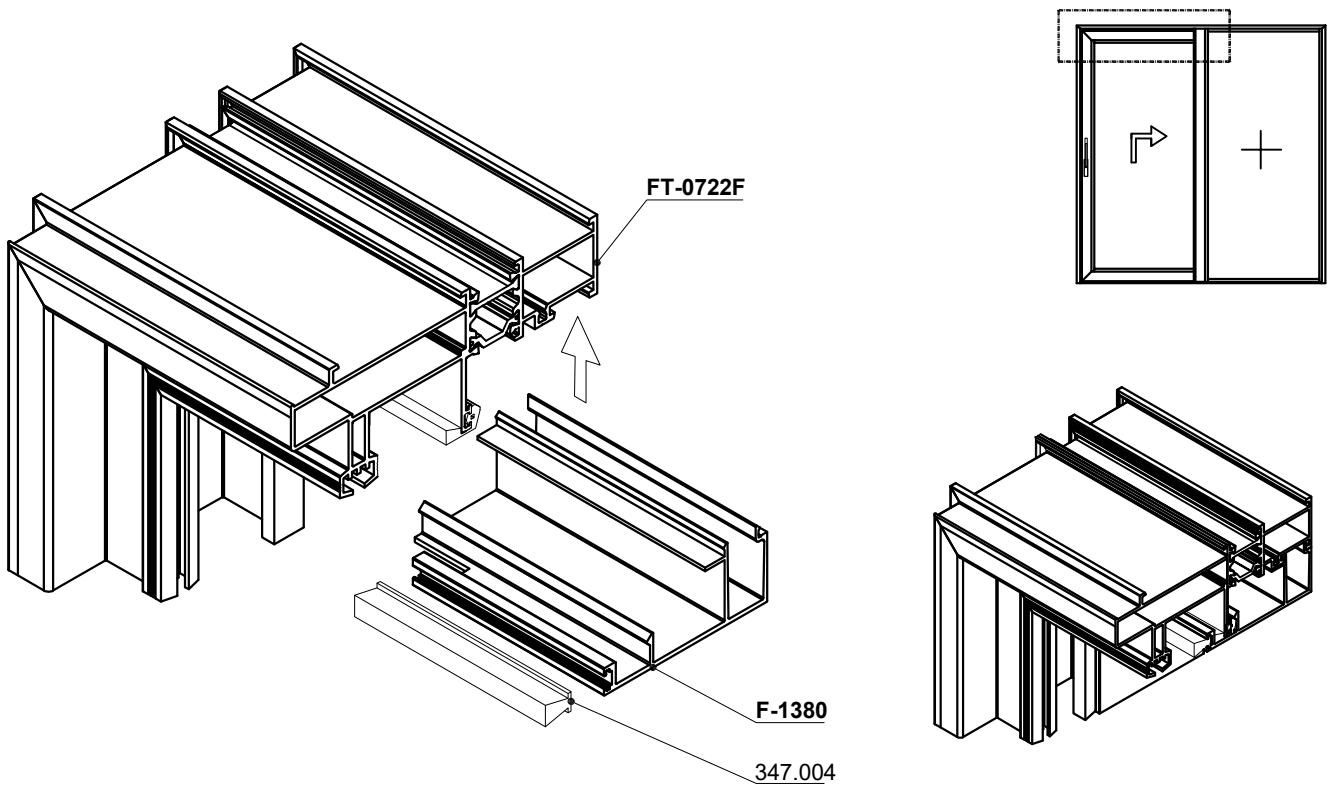
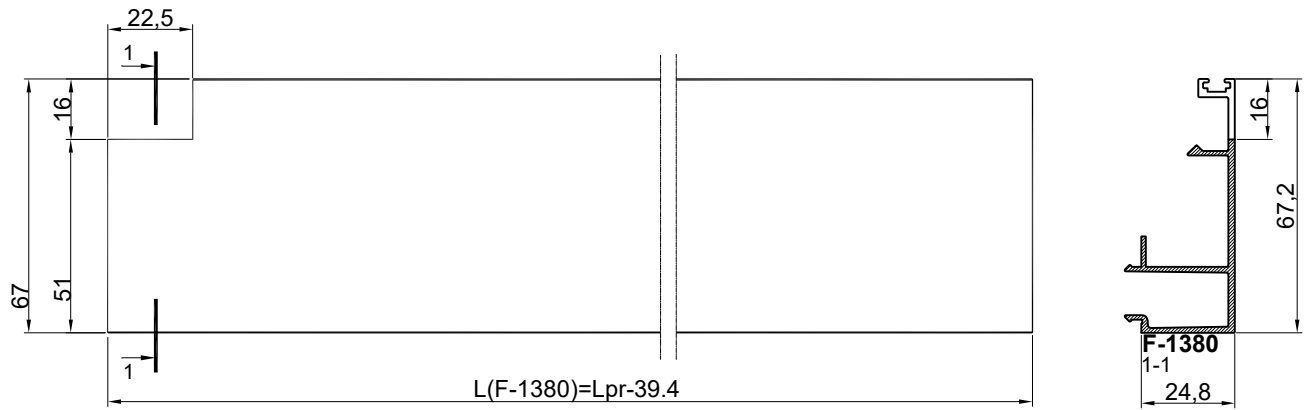
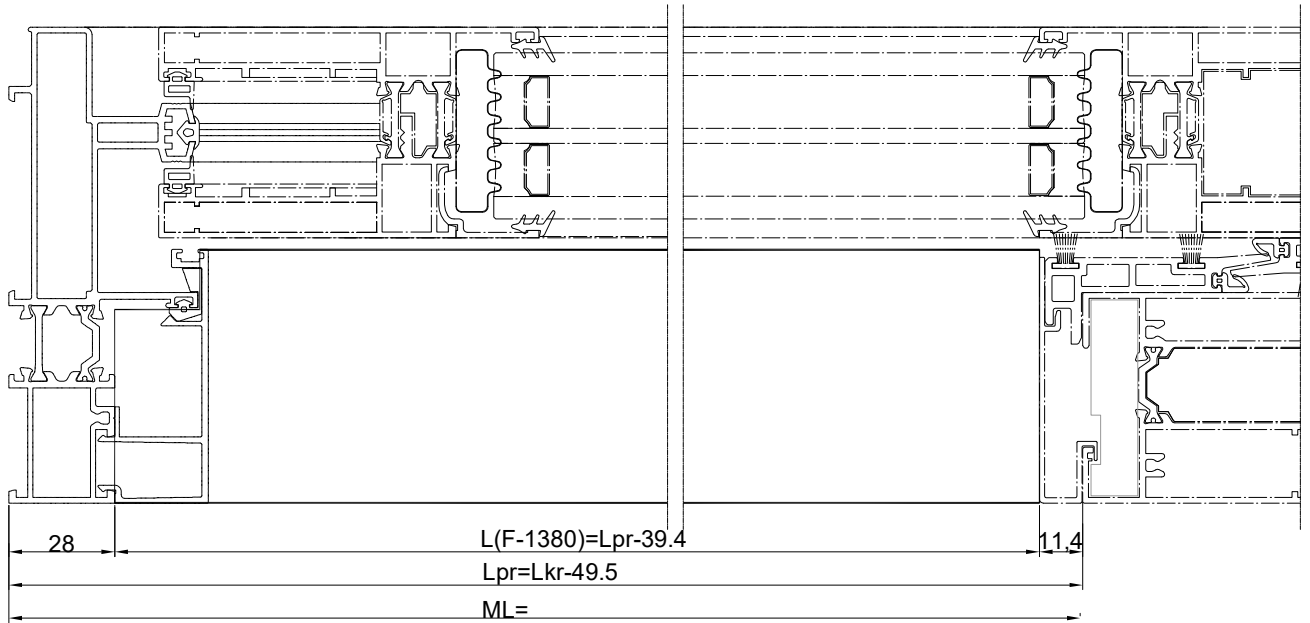

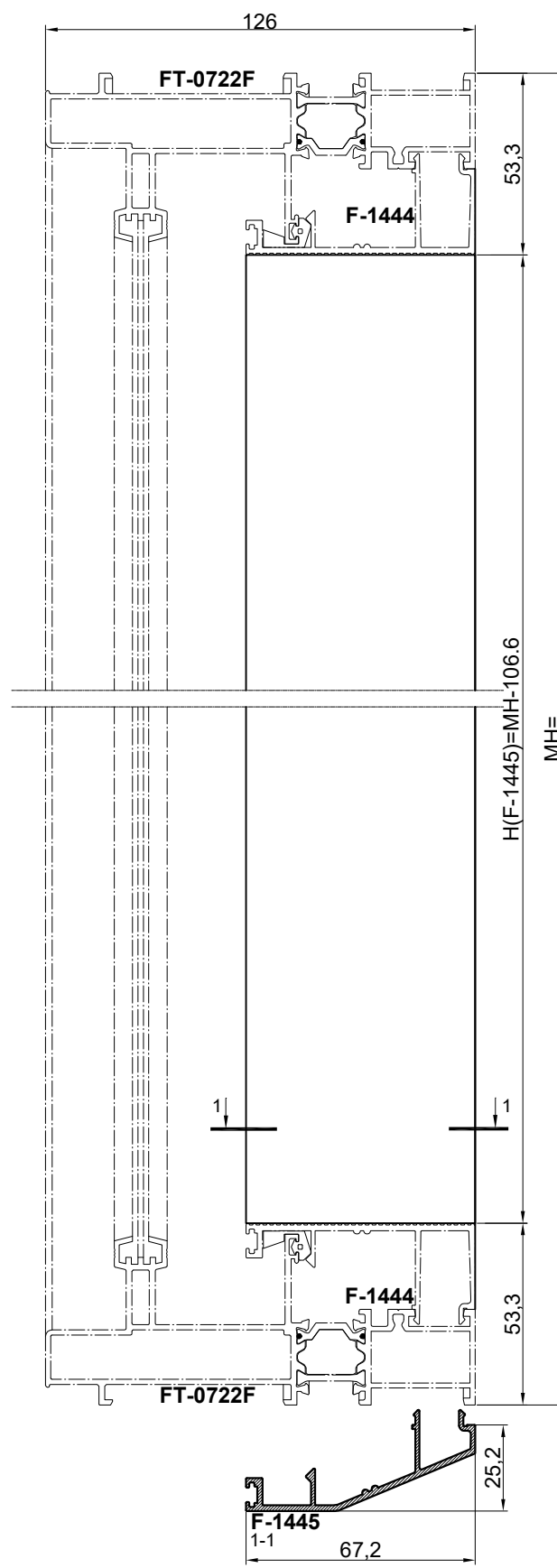
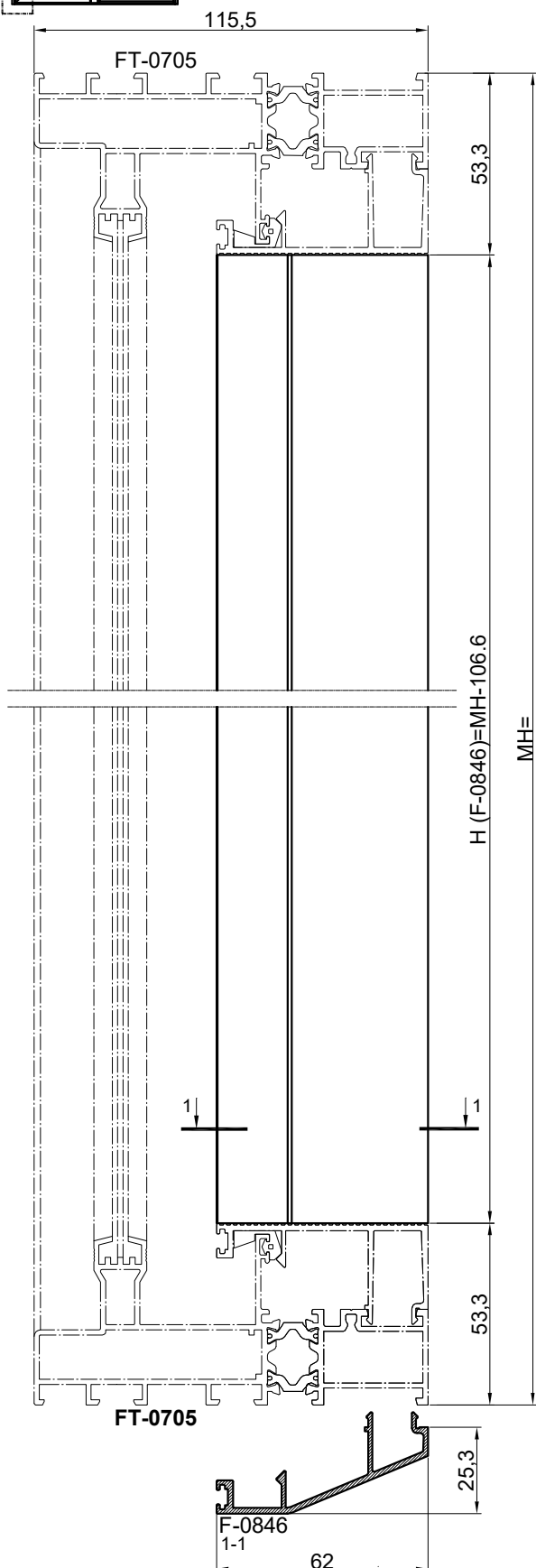
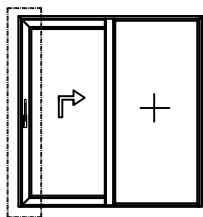

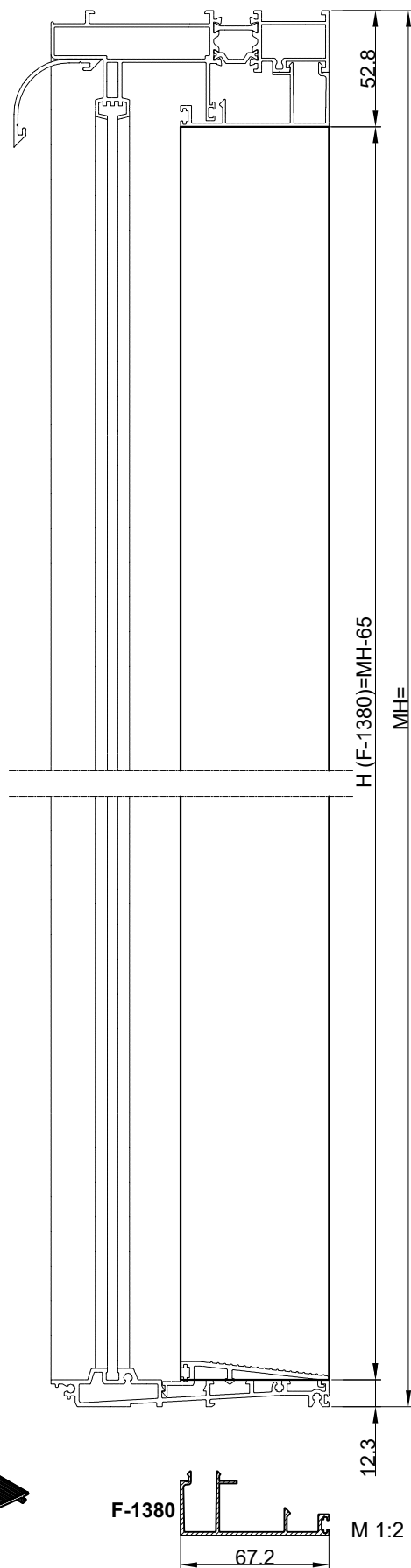
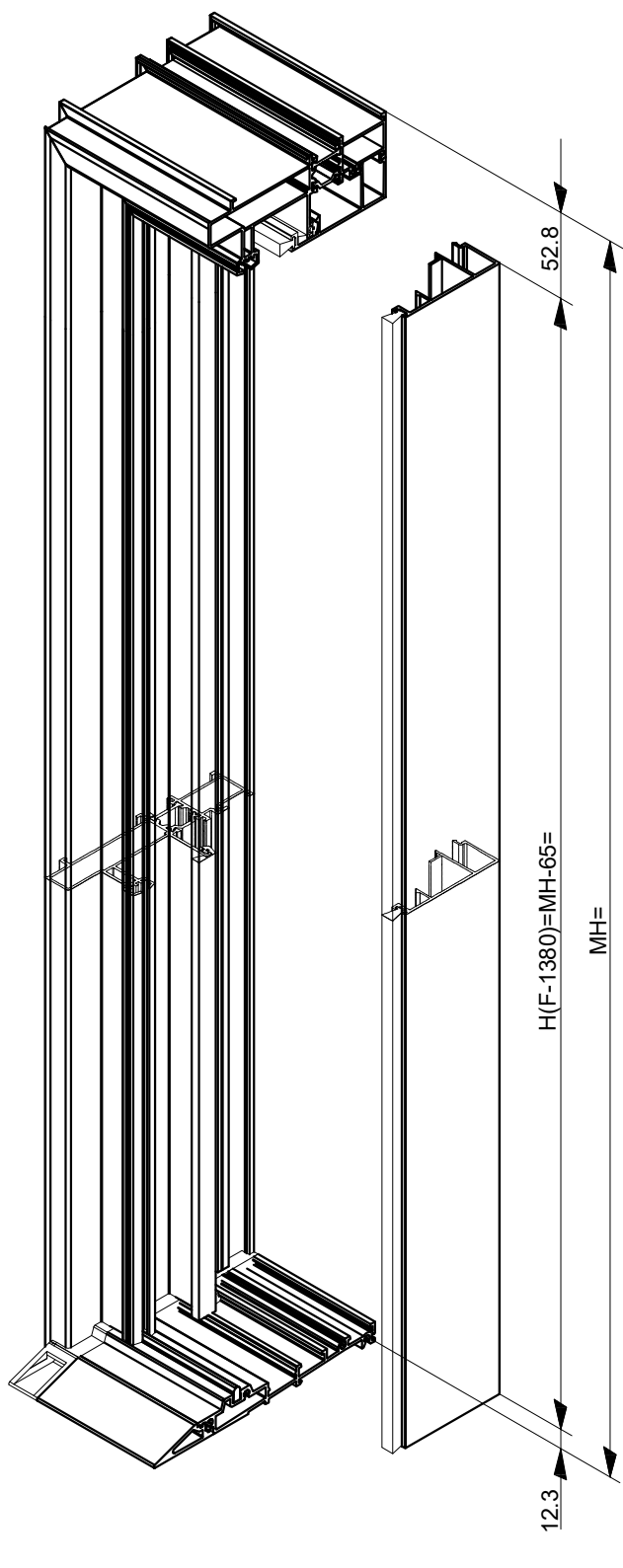
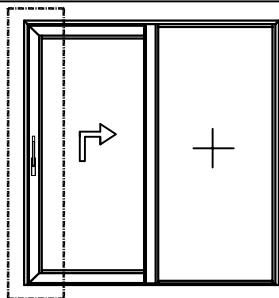

### SPAJANJE PROFILA PRAGA SA PROFILOM RAMA POMOĆU UMETKA

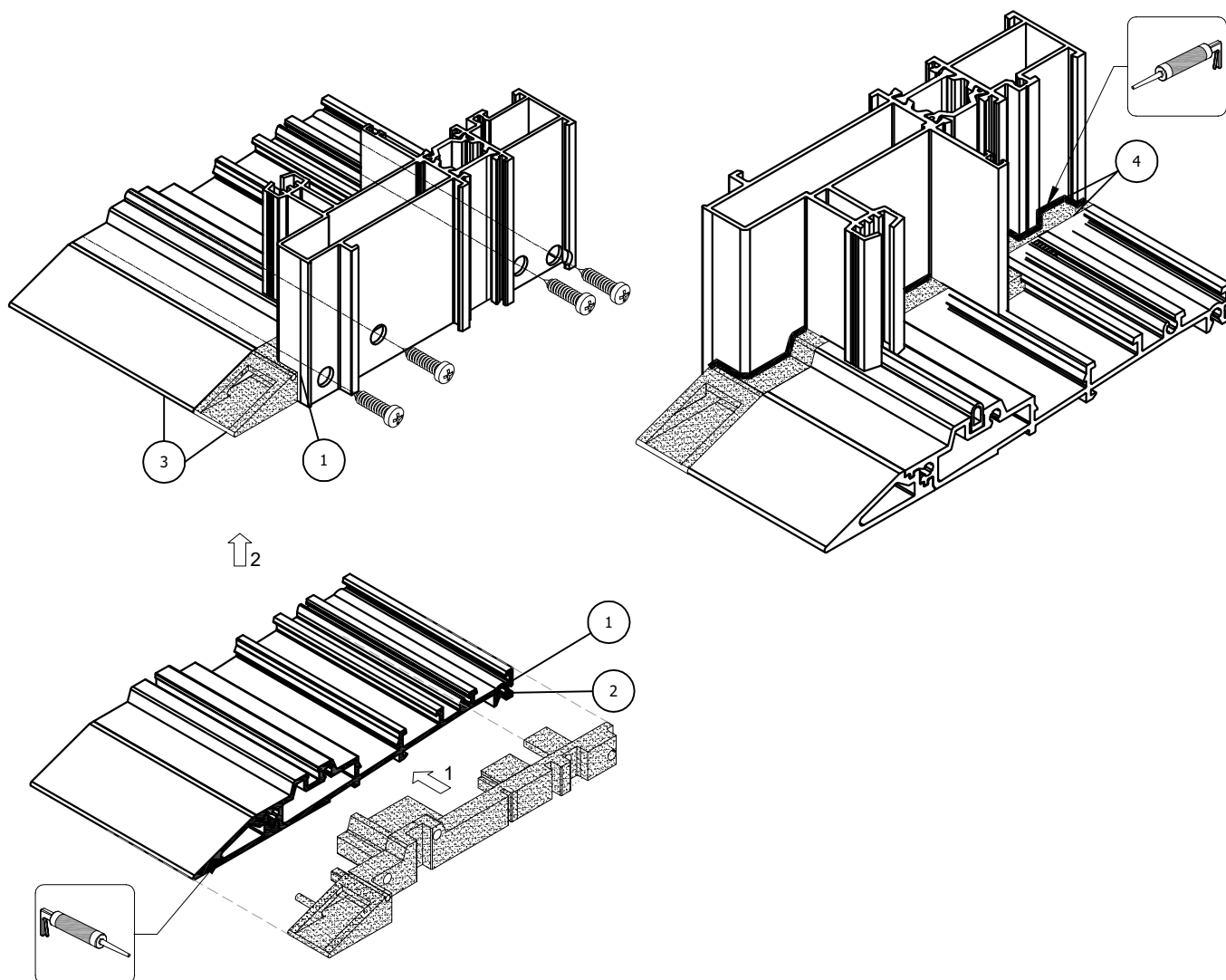

#### POSTUPAK SPAJANJA PROFILA :

1. Sve površine koje se spajaju-rezove očistiti i odmastiti odgovarajućim sredstvom /npr. "Henkel" - *Teroson VR 20 ili Teroson FL+ /*.
2. Na profilu praga premazati sve površine koje se spajaju ljepljivom za metal /npr. "Henkel" - *Teroson MS 939 /*.
- 2.1. Ljepljivo za metal ubrizgati u komore profila praga na mjestima gdje ulazi umetak (po opsegu komore)
3. Profil praga i umetak izravnati i spojiti.
4. Profil praga sa spojenim umetkom izravnati i spojiti sa profilom rama.
- 5. Nakon spajanja profila, sve spojeve profila i umetka ispuniti ljepljivom za metal /npr. "Henkel" - *Teroson MS 939 /*.**
6. Dio ljepljiva koji iscuri između rezova očistiti sredstvom za čišćenje i odmašćivanje /npr. "Henkel" - *Teroson VR 20 ili Teroson FL+ /*.

#### NAPOMENA:

Lijepljenjem rezova, kao i svih spojeva profila sa ljepljivima za metal, osigurava se potrebna zrako i vodonepropusnosti spoja kao i dodatna mehanička čvrstoća spoja.

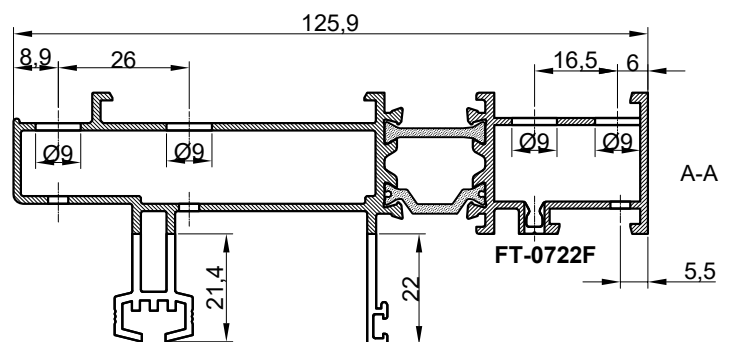
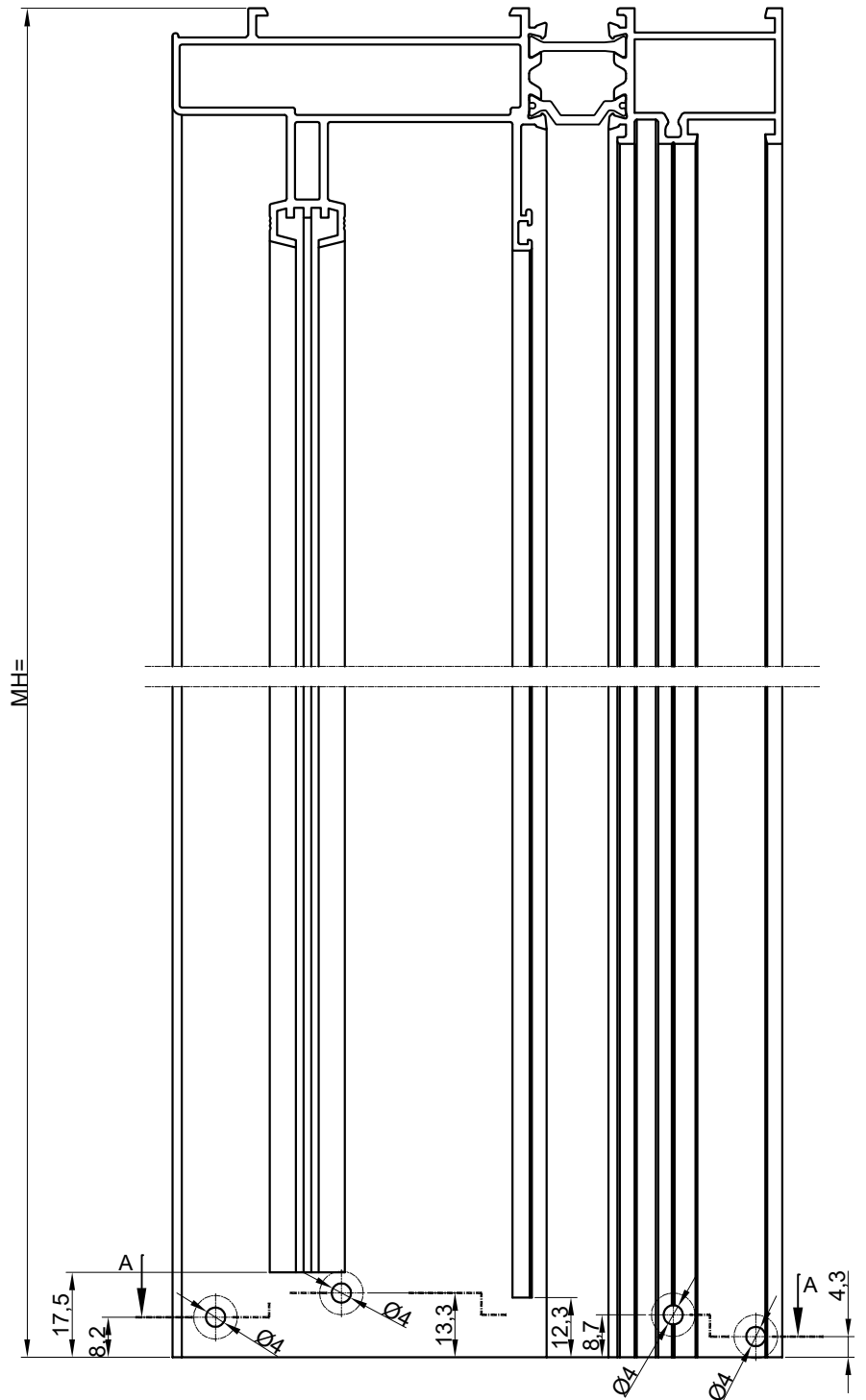
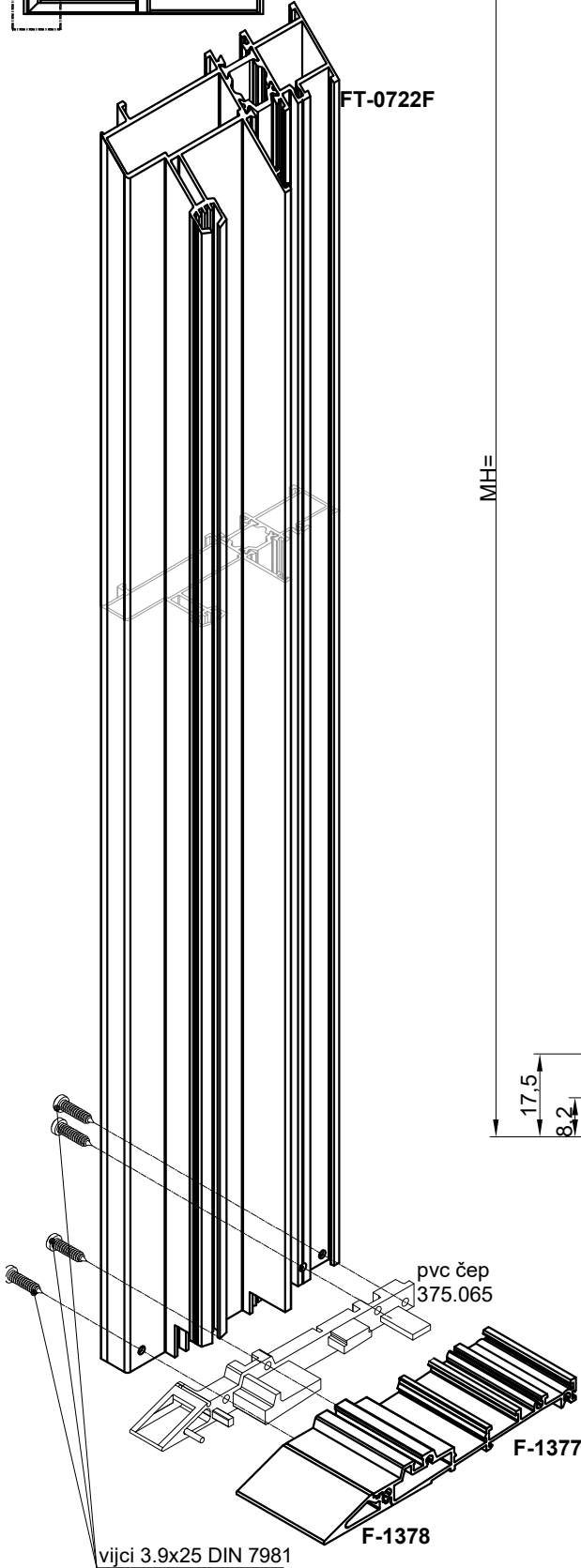
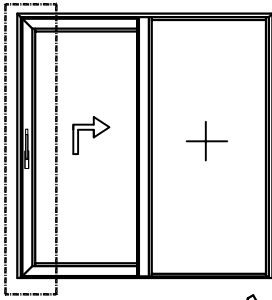

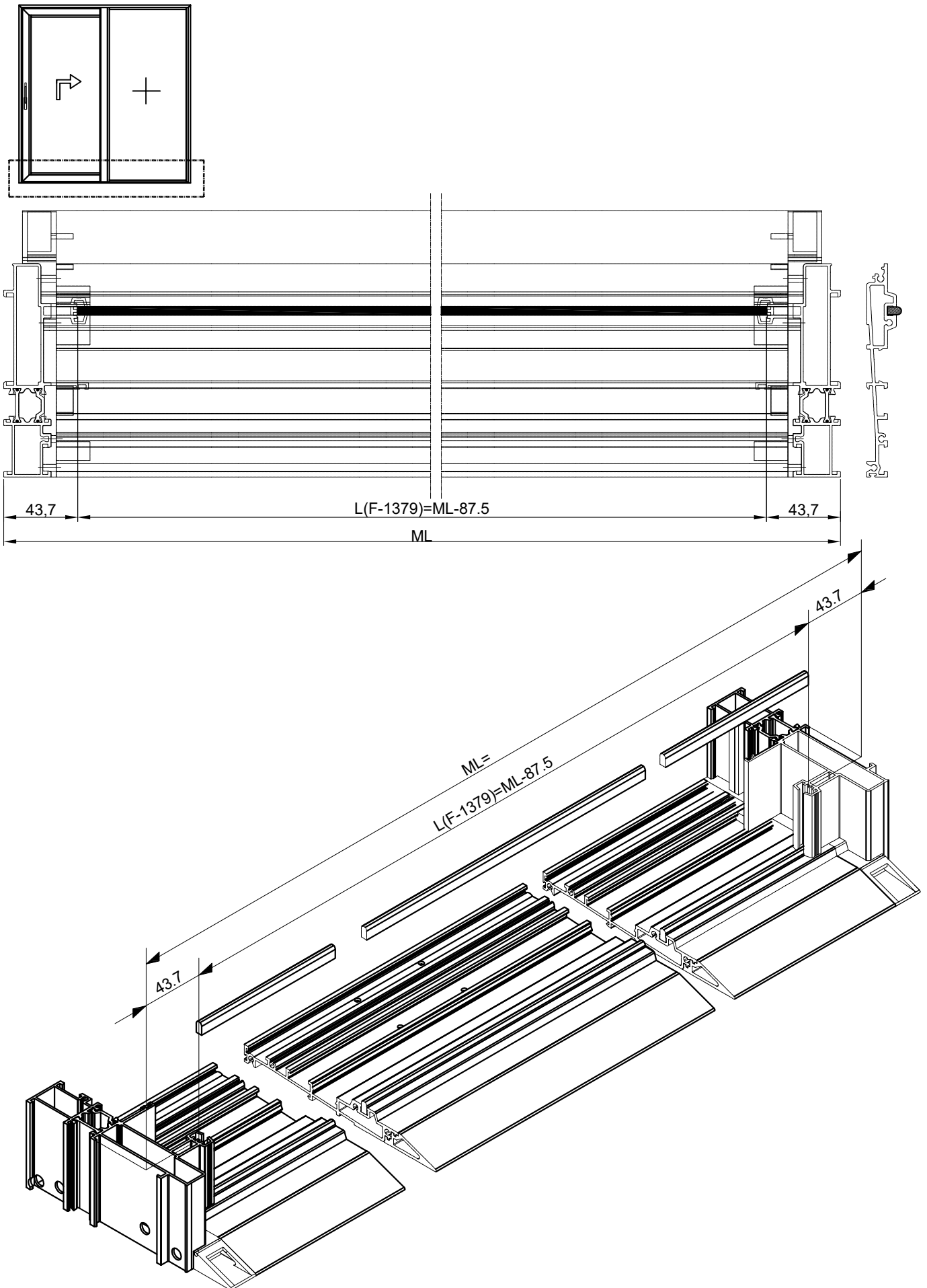

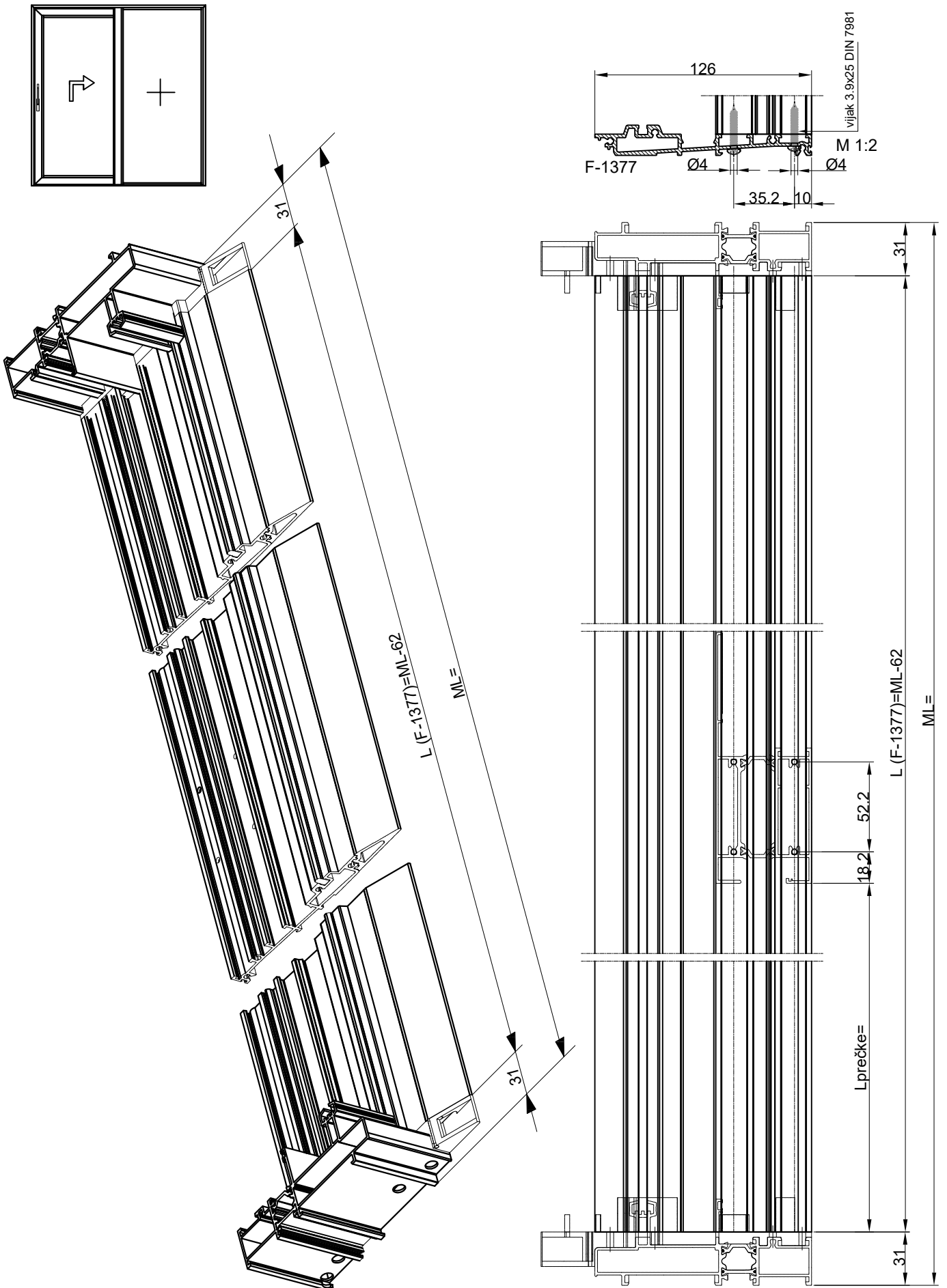

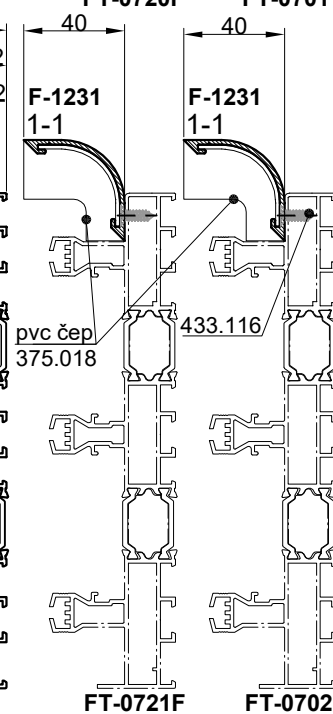
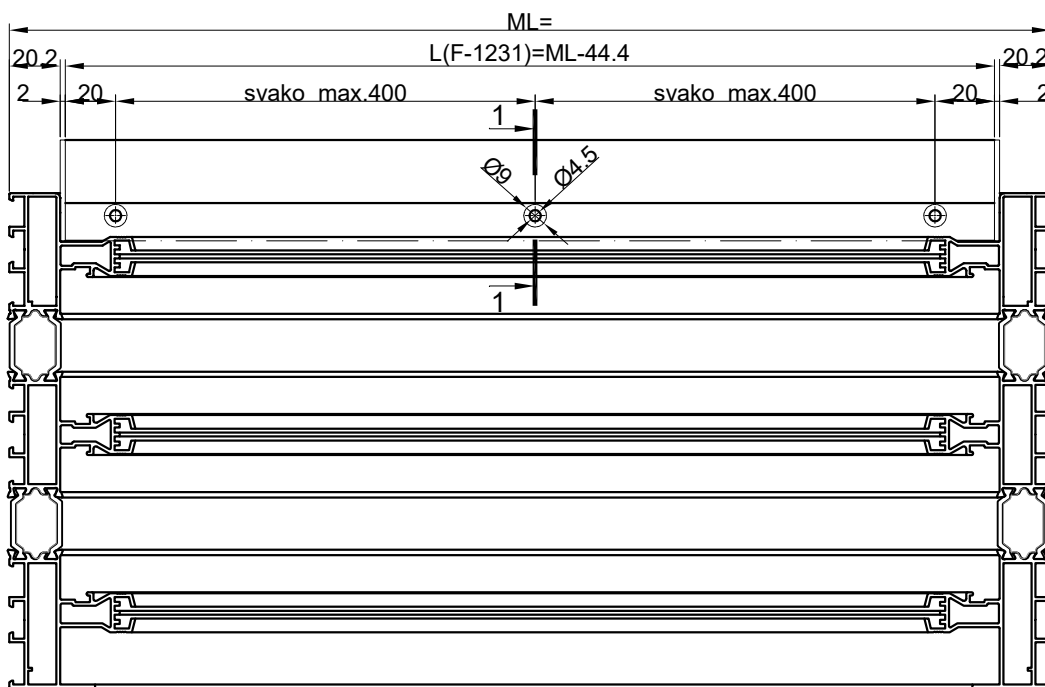
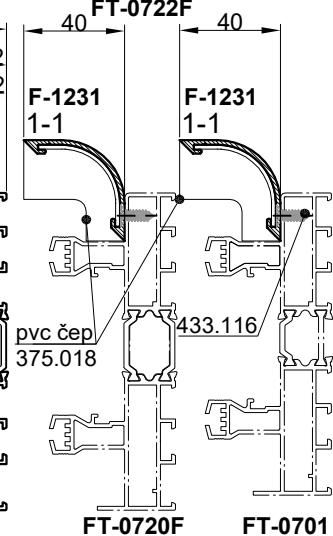
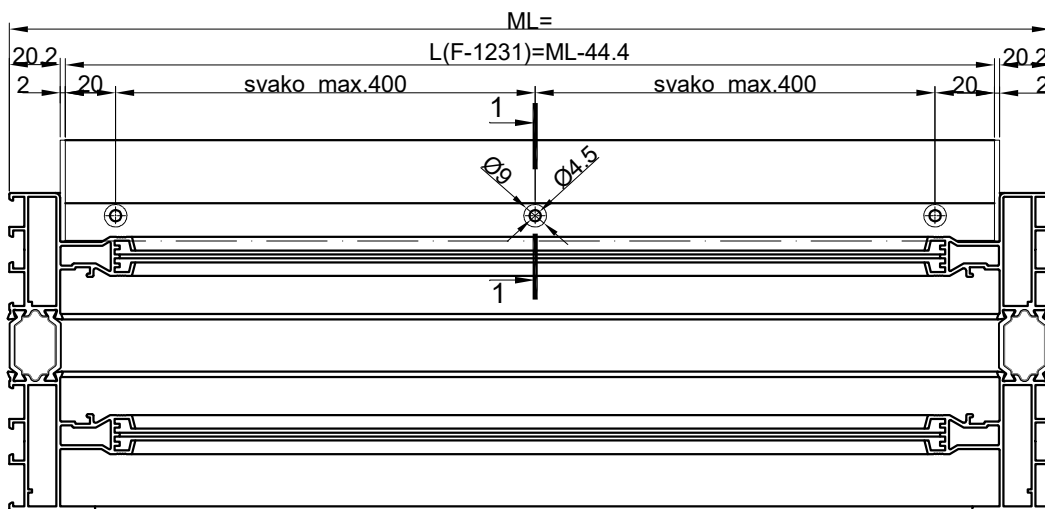
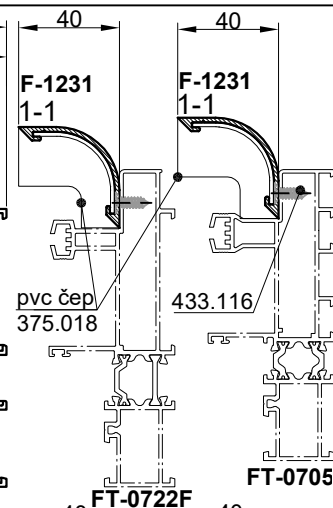
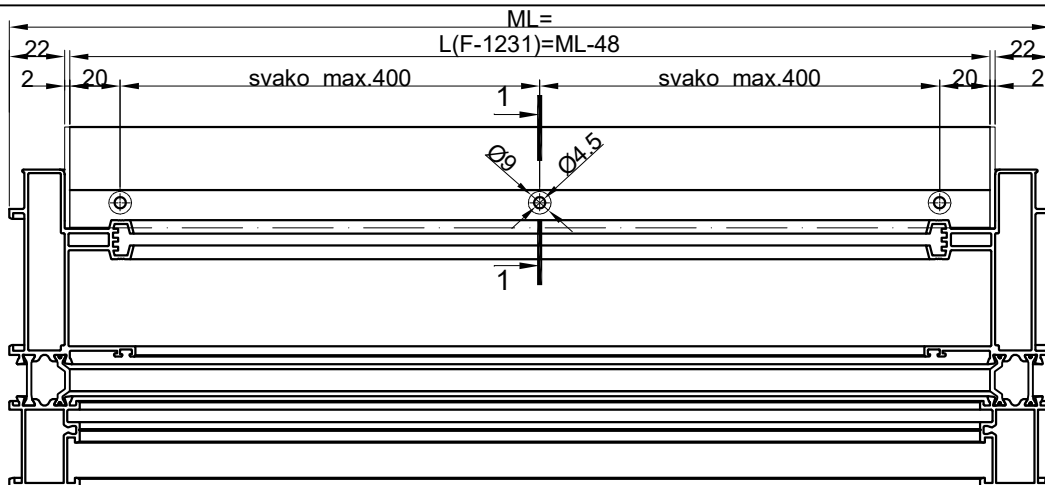

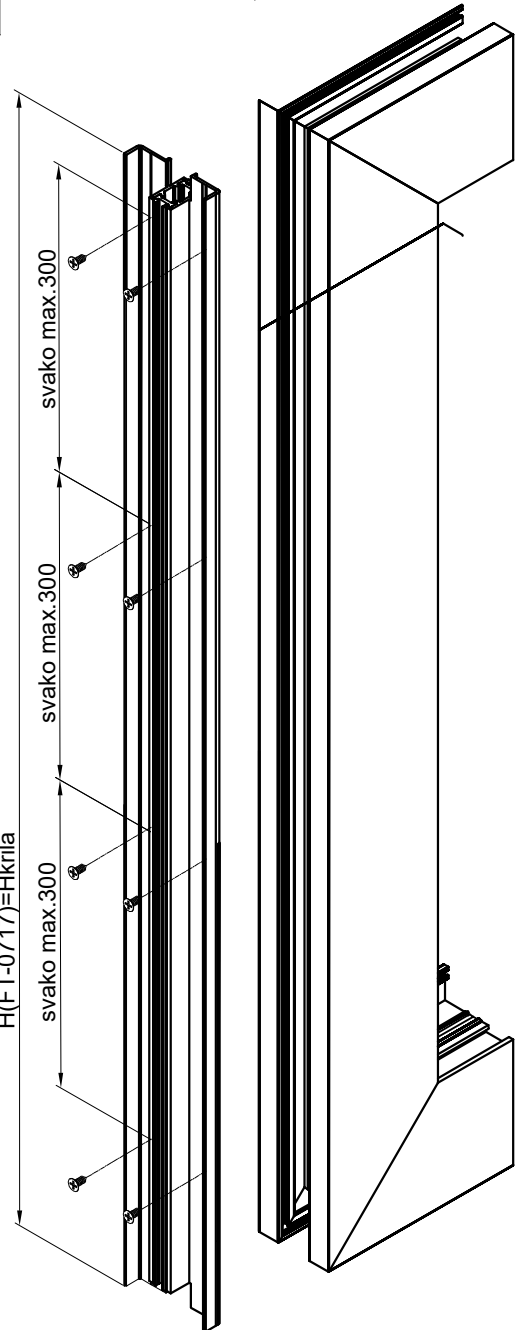
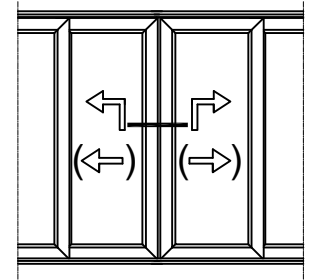
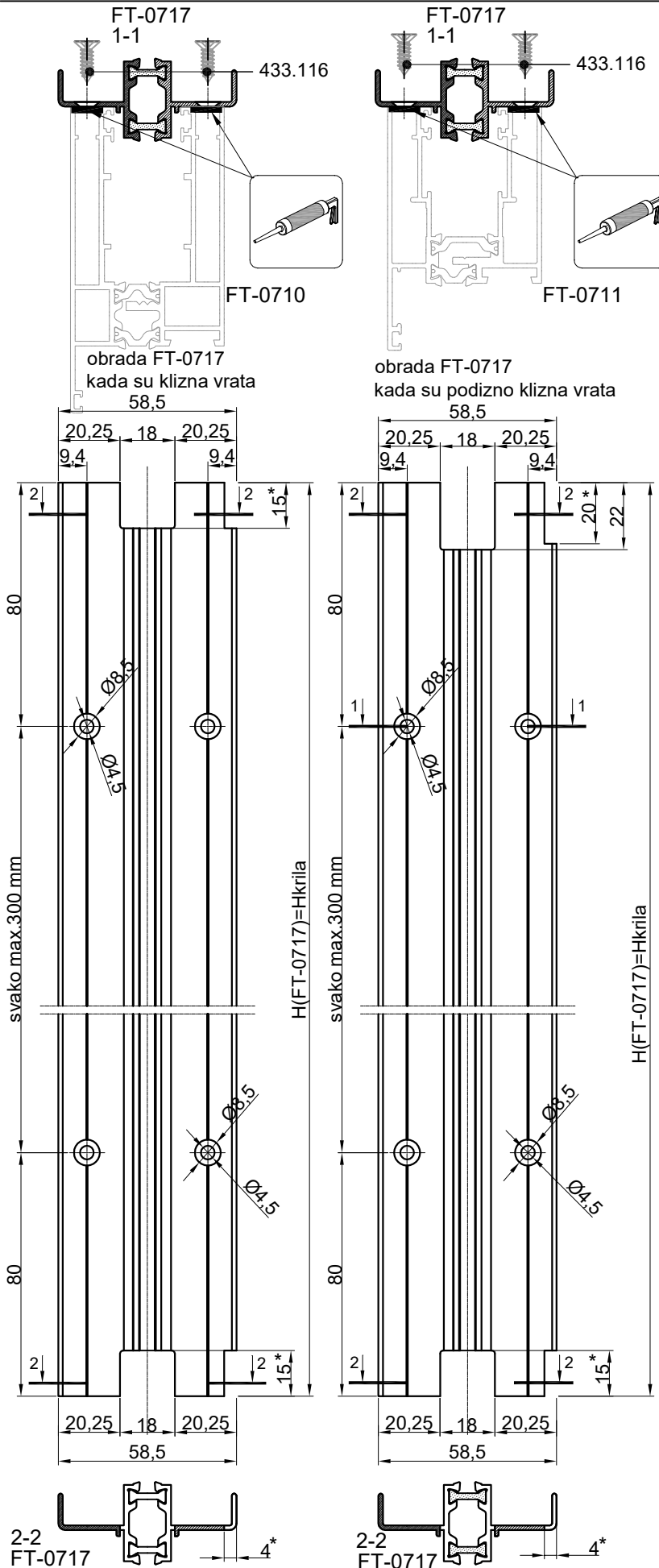

\* OBRADUJE SE SAMO ZA SHEMU (dva srednja krila klizna ili podizno klizna bokovi fiksni-Termo 120 plus)

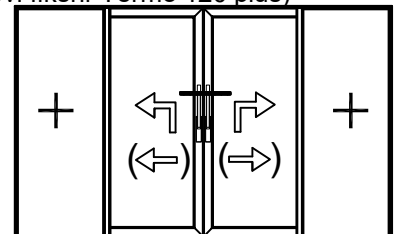

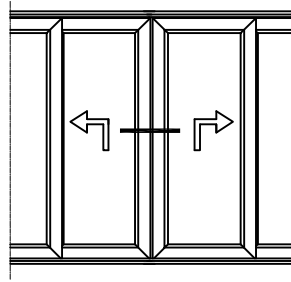
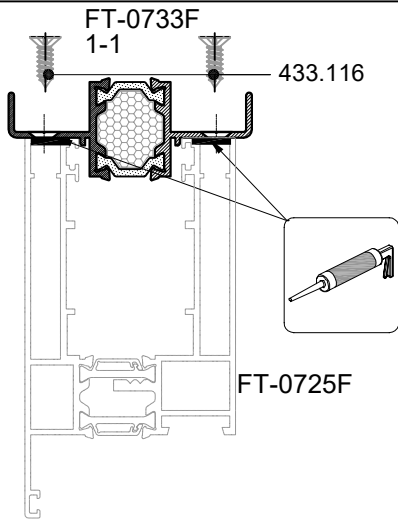

obrada FT-0733F  
kada su podizno klizna vrata

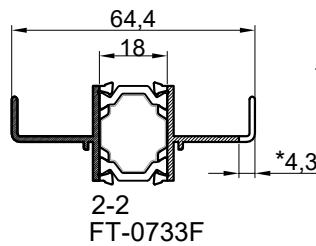
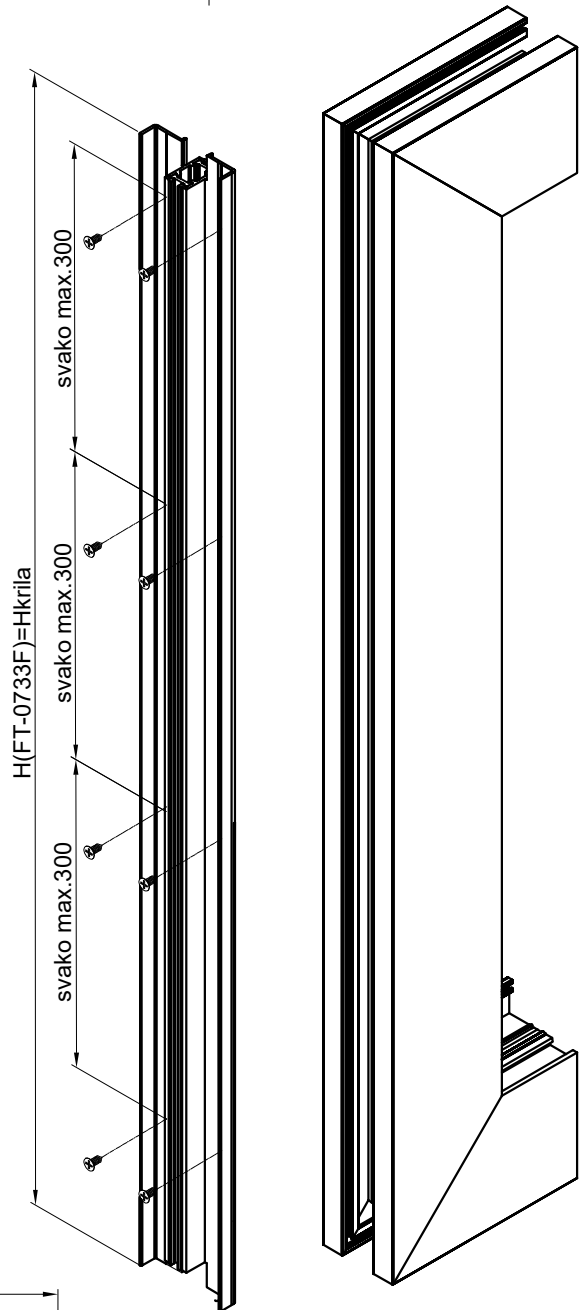
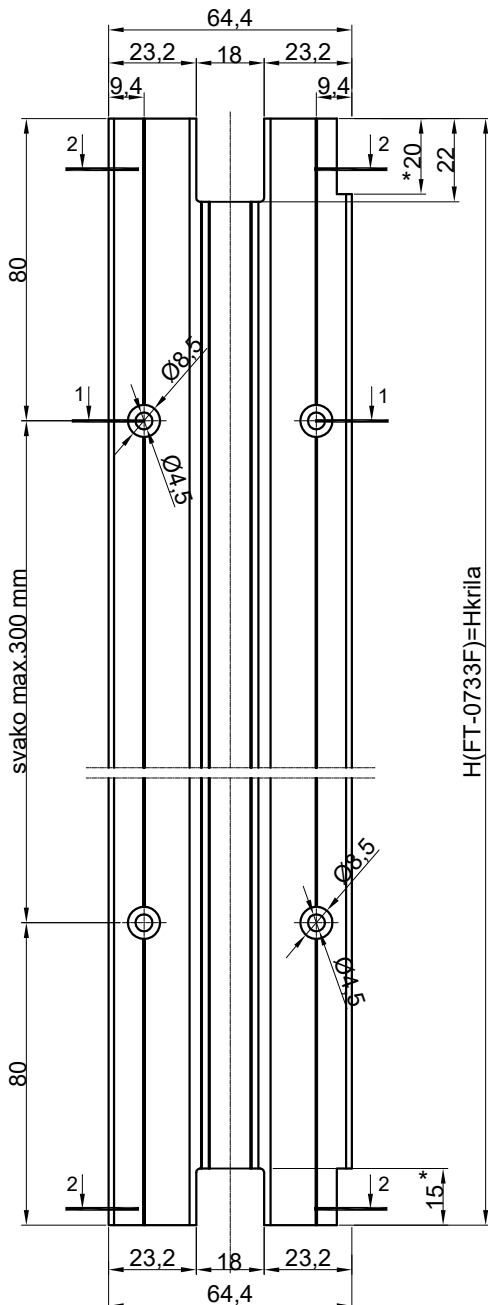

\* OBRADUJE SE SAMO ZA SHEMU  
(dva srednja krila podizno klizna  
bokovi fiksni-Termo 120 plus)

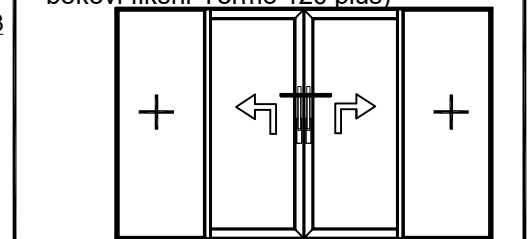

433.109  
vijci 3.9x32 DIN 7982  
čep 363.049  
brtva 344.075

krilo  
FT-0725F

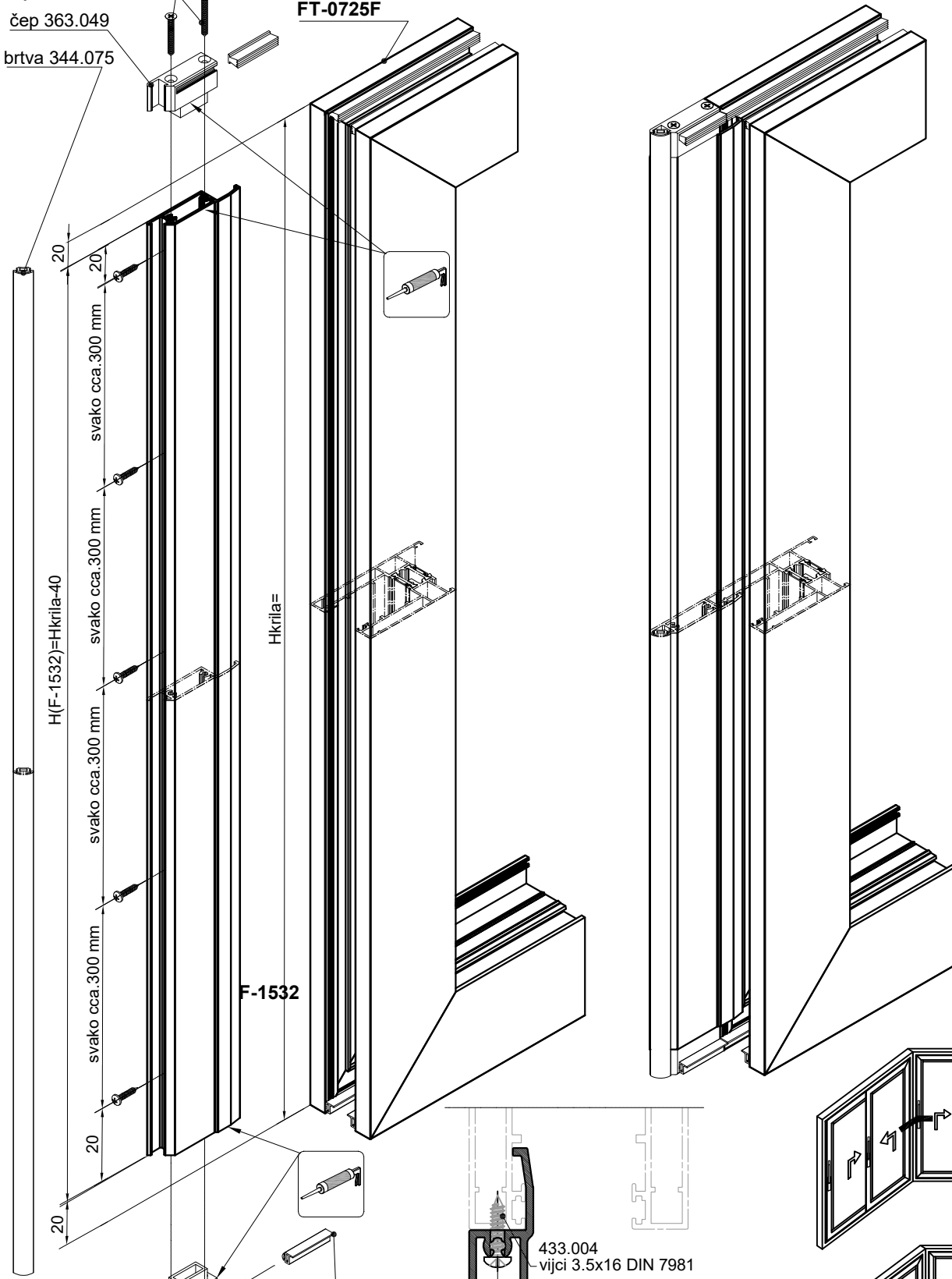

čep 363.049  
433.109  
vijci 3.9x32 DIN 7982

brtva 344.048

433.004  
vijci 3.5x16 DIN 7981  
F-1532

Ø8  
7.2  
M 2:1

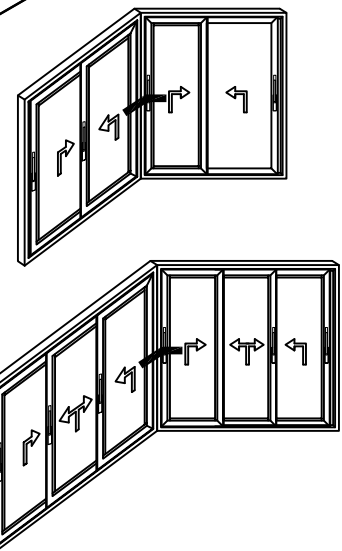



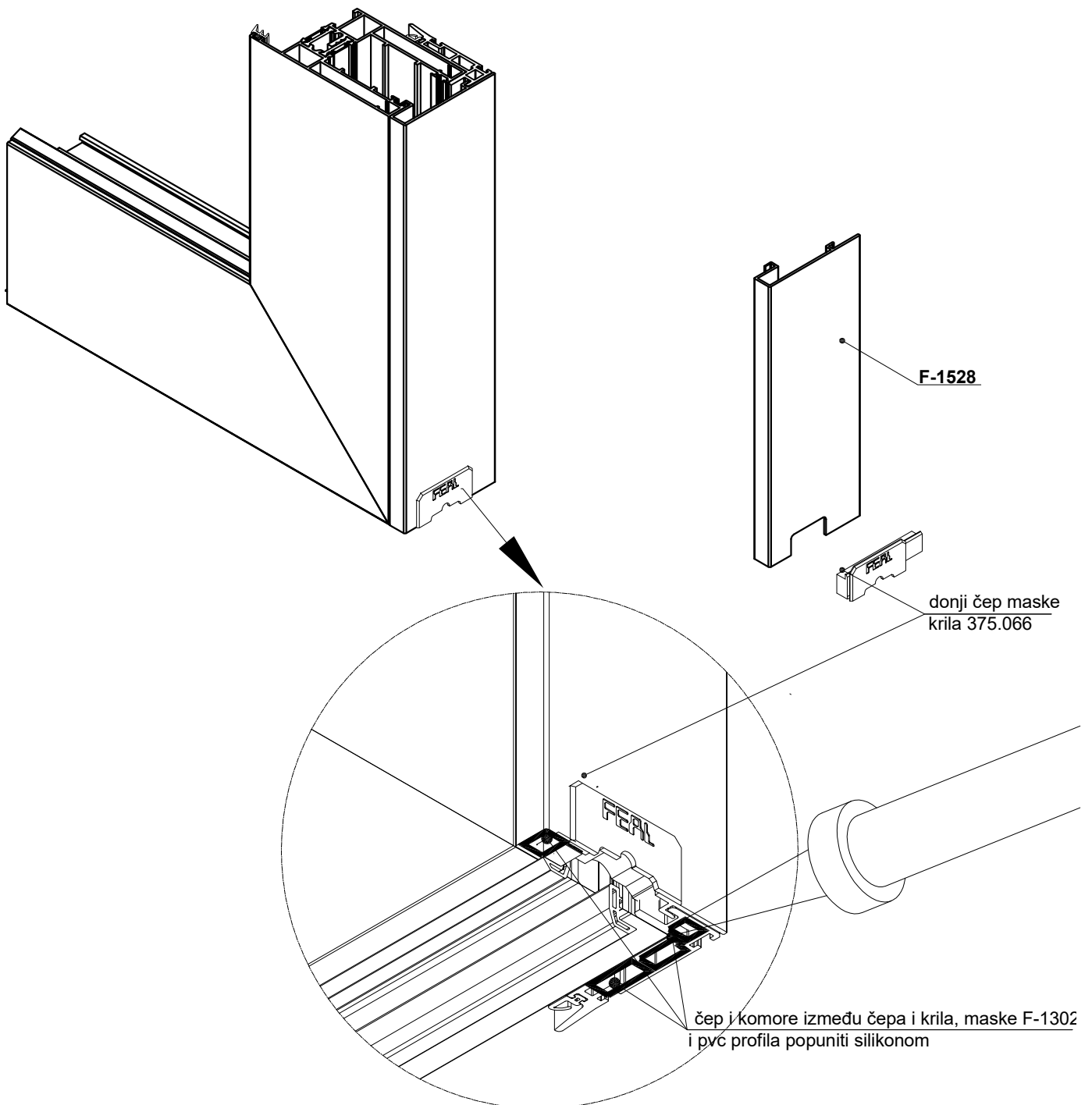
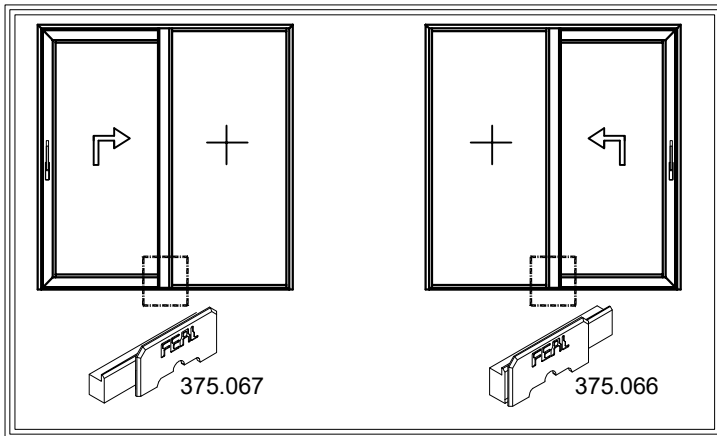

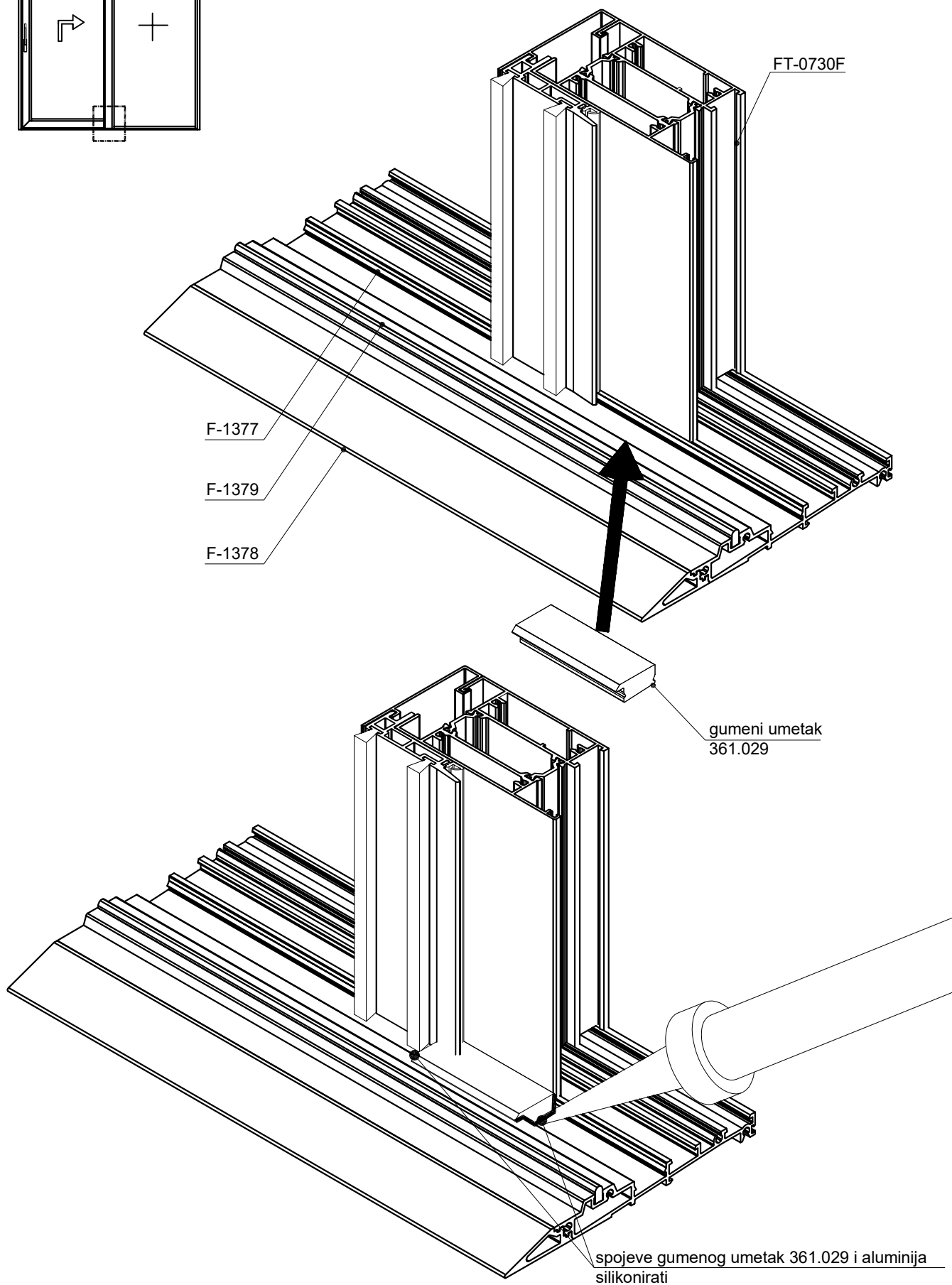
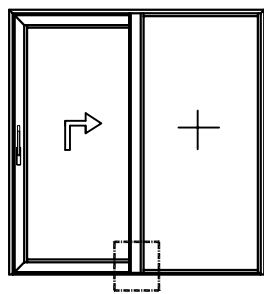

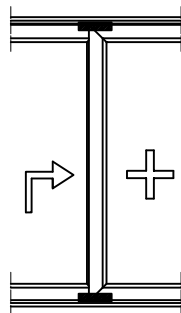

za TERMO 120 plus na spoju koristiti umetak 340.402 u gornjem dijelu; u donjem dijelu se koristi gumeni umetak 363.019 za krila FT-0710 i FT-0711.

ram FT-0705

umetak sa četkicom na spoju dva krila 340.402

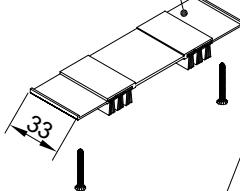

gumeni umetak 363.019

ram FT-0705

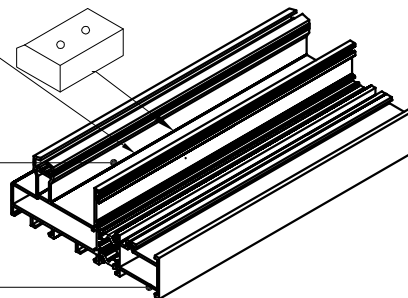
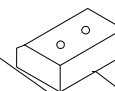
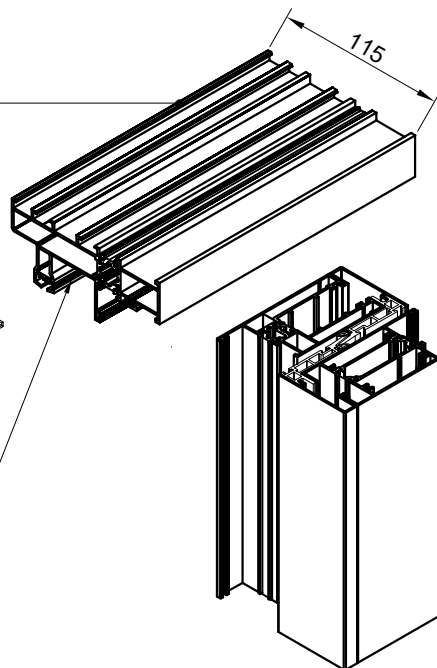

340.005 (krilo FT-0711)  
340.402 (krilo FT-0710)

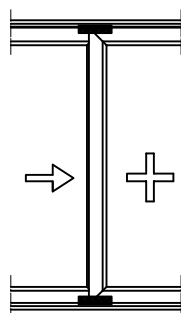

za TERMO 120 plus na spoju koristiti umetak - 340.005...krila FT-0710 i FT-0711

ram FT-0705

umetak sa četkicom na spoju dva krila 340.005

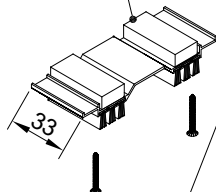

umetak sa četkicom na spoju dva krila 340.005

ram FT-0705

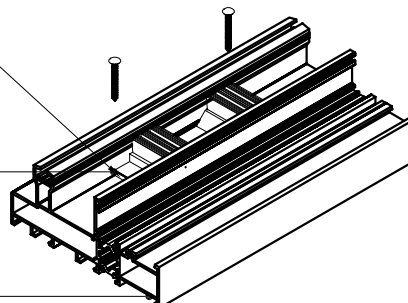
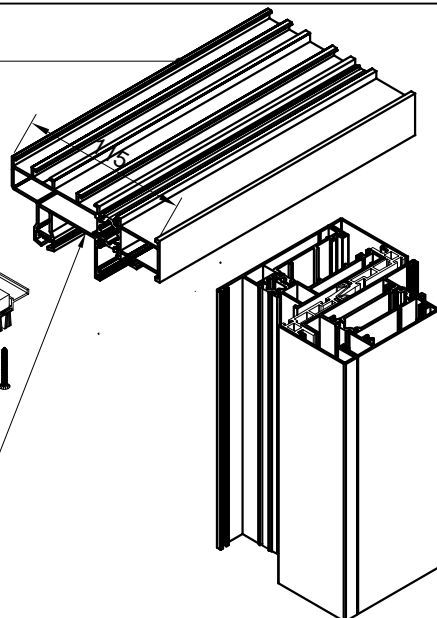

340.007 (krilo FT-0710)  
340.006 (krilo FT-0711)

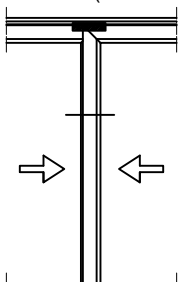

340.007-krilo FT-0710  
340.006-krilo FT-0711

340.007-krila FT-0710 i FT-0711

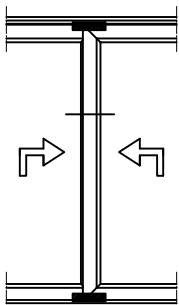

360.012-krilo FT-0710  
340.013-krilo FT-0711

**ram FT-0701 (dvije staze)**  
**ram FT-0702 (tri staze)**  
**ram FT-0703 (dvije staze)**  
**ram FT-0704 (tri staze)**

umetak sa četkicom na spoju dva krila 340.007

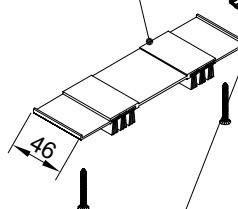

umetak sa četkicom na spoju dva krila 340.007

**ram FT-0701 (dvije staze)**  
**ram FT-0702 (tri staze)**  
**ram FT-0703 (dvije staze)**  
**ram FT-0704 (tri staze)**

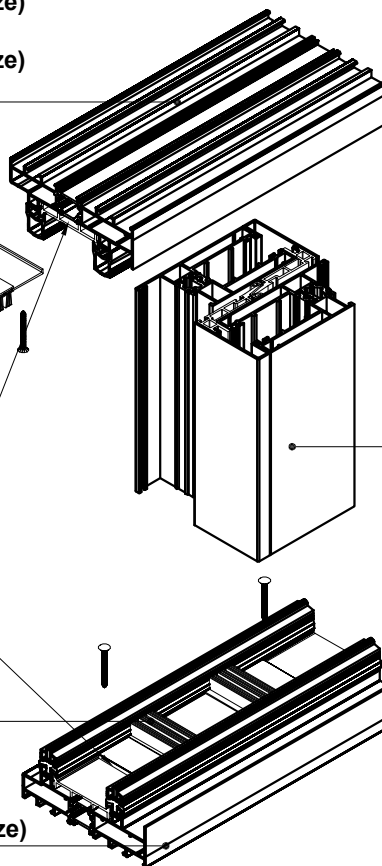

spoj dva krila FT-0710

za TERMO 120-D na spoju koristiti umetak 340.041 u gornjem položaju

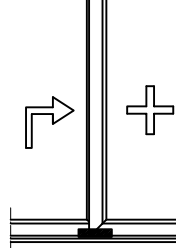

**ram FT-0722F**

za TERMO 120-D na spoju koristiti umetak 340.043 u donjem položaju; umetak 340.041 u gornjem položaju

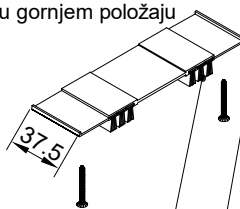

umetak sa četkicom na spoju dva krila 340.041

gumeni umetak na spoju dva krila 360.015

**ram FT-0722F**

za TERMO 120-D na spoju koristiti umetak 340.046

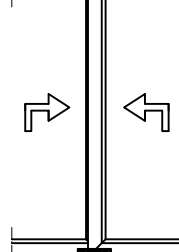

za TERMO 120-D na spoju koristiti umetak 360.014

umetak sa četkicom na spoju dva krila 340.046

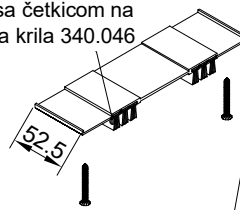

gumeni umetak na spoju dva krila 360.014

**ram FT-0720F (dvije staze)**  
**ram FT-0721F (tri staze)**

**ram FT-0720F (dvije staze)**  
**ram FT-0721F (tri staze)**

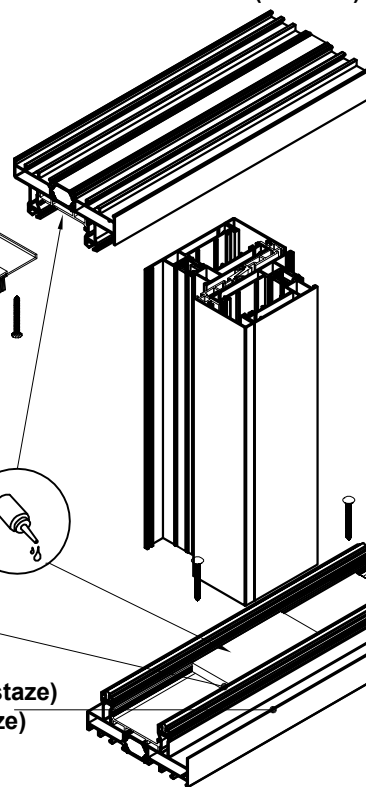

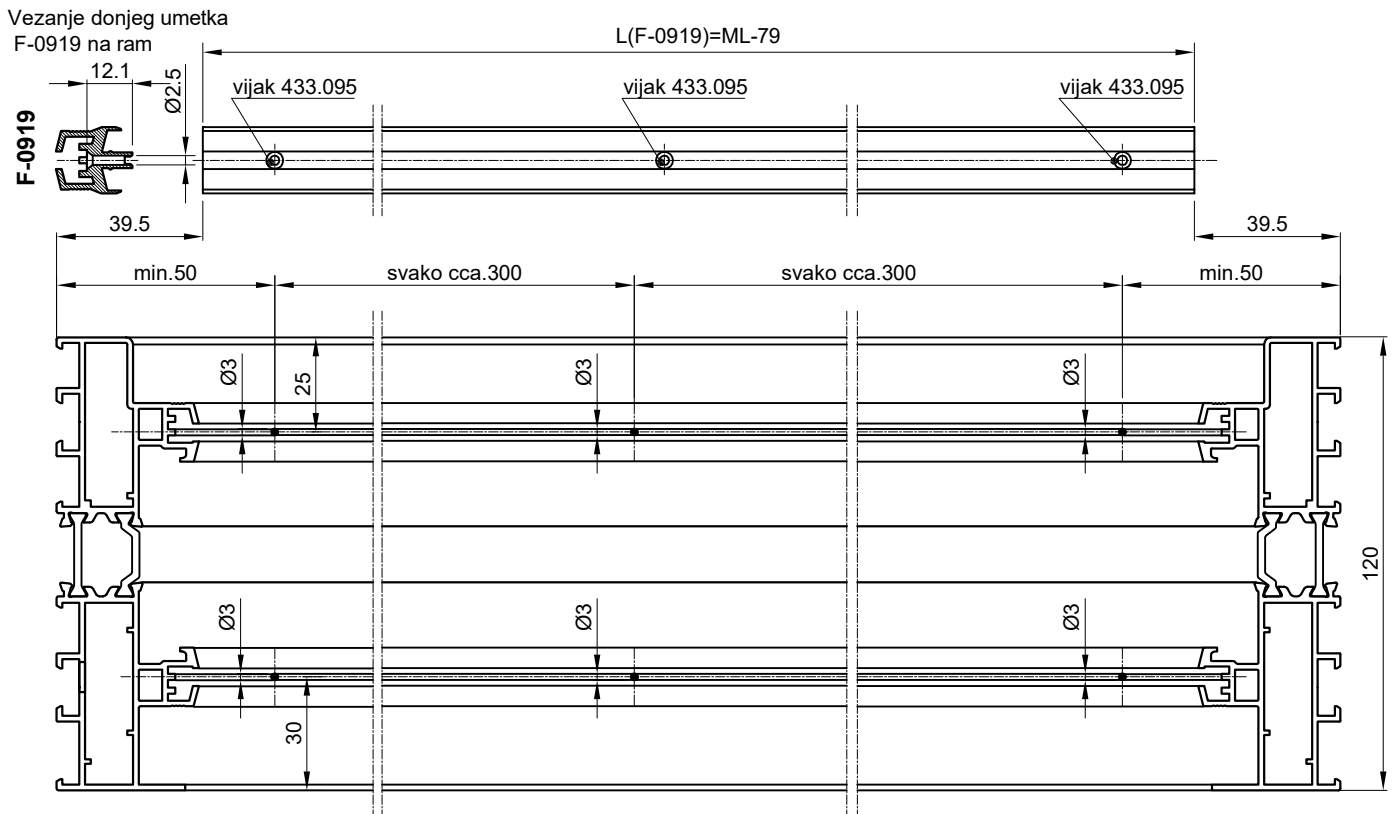
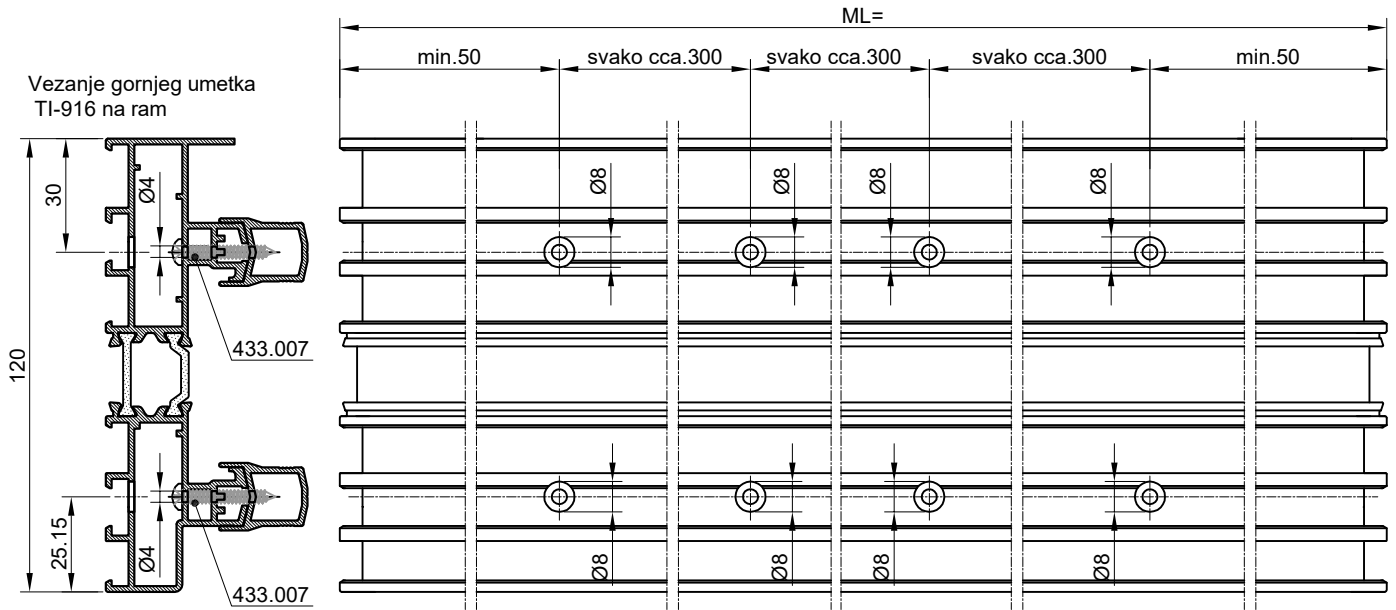
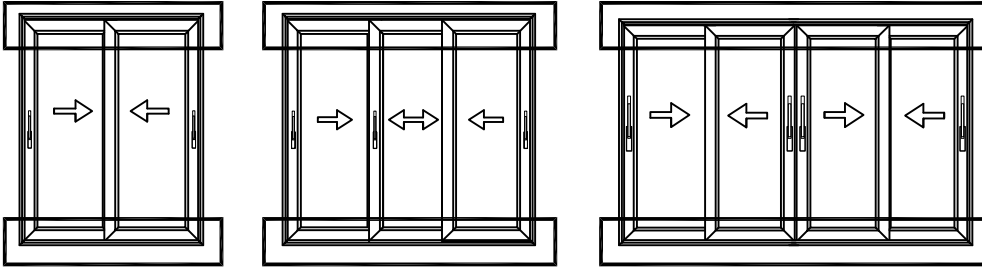

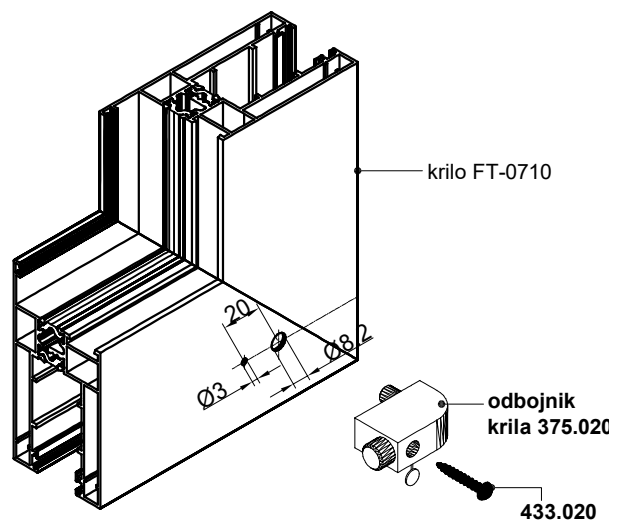
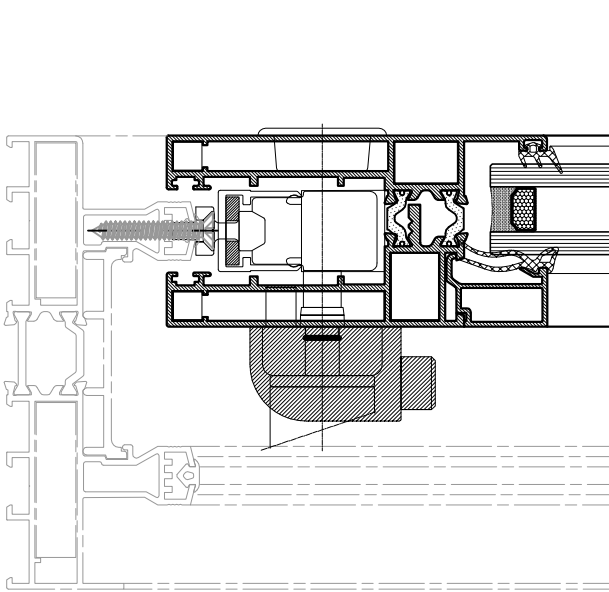
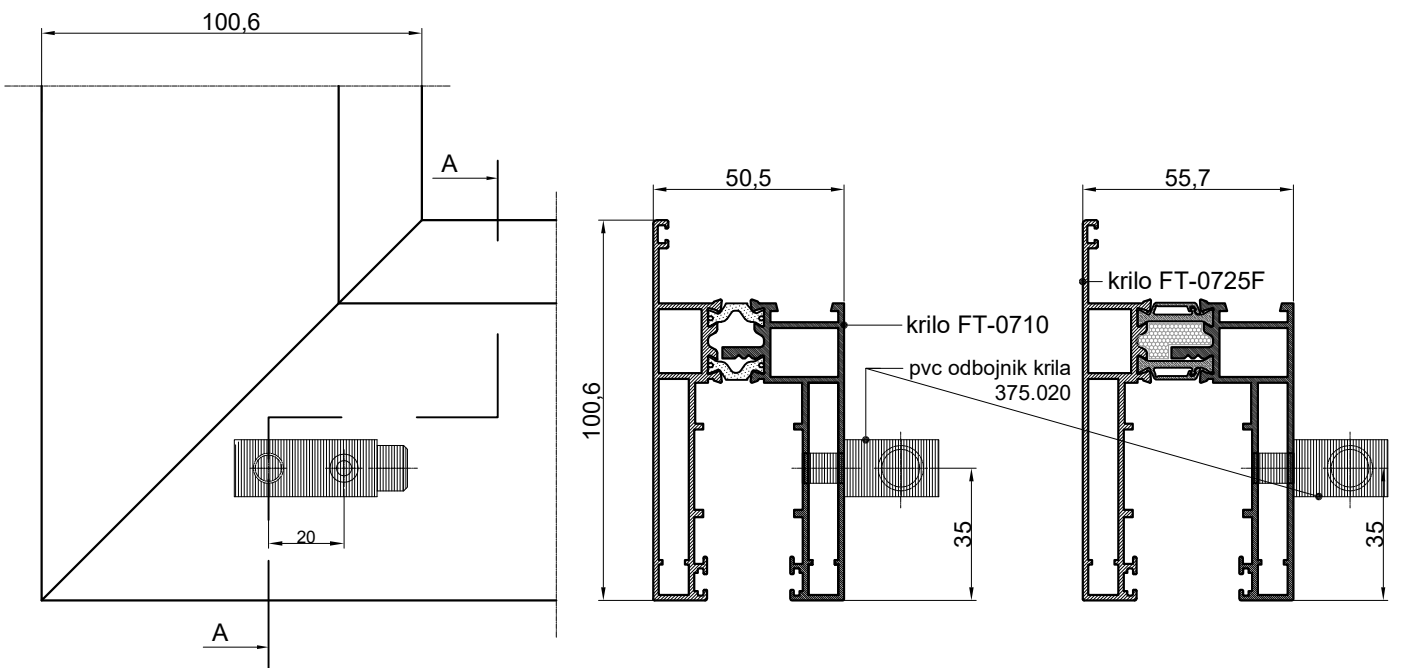
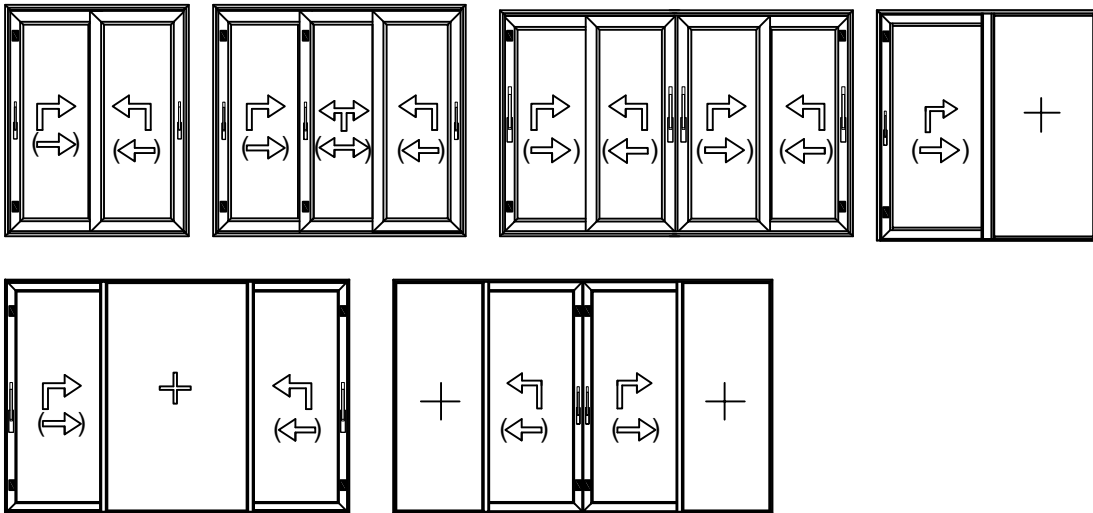

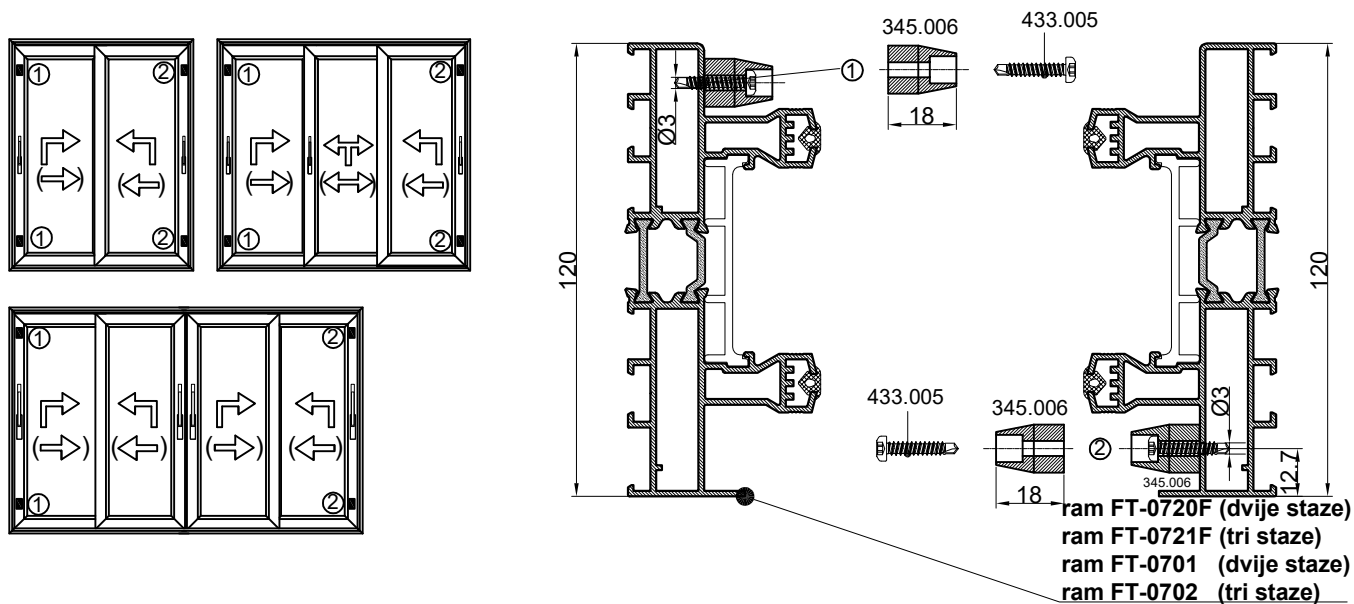
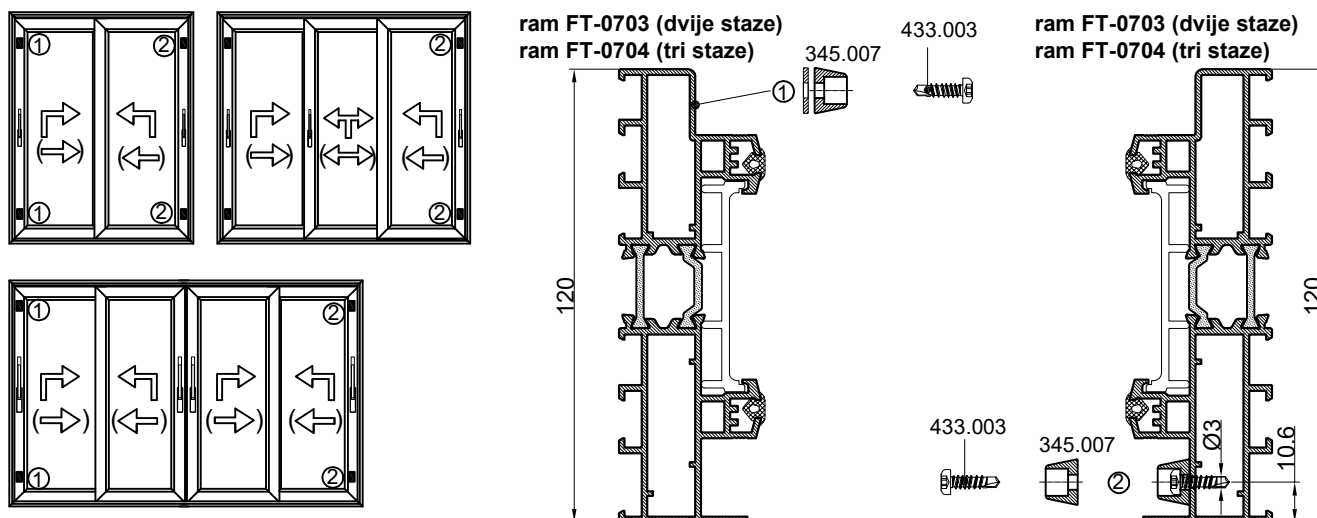
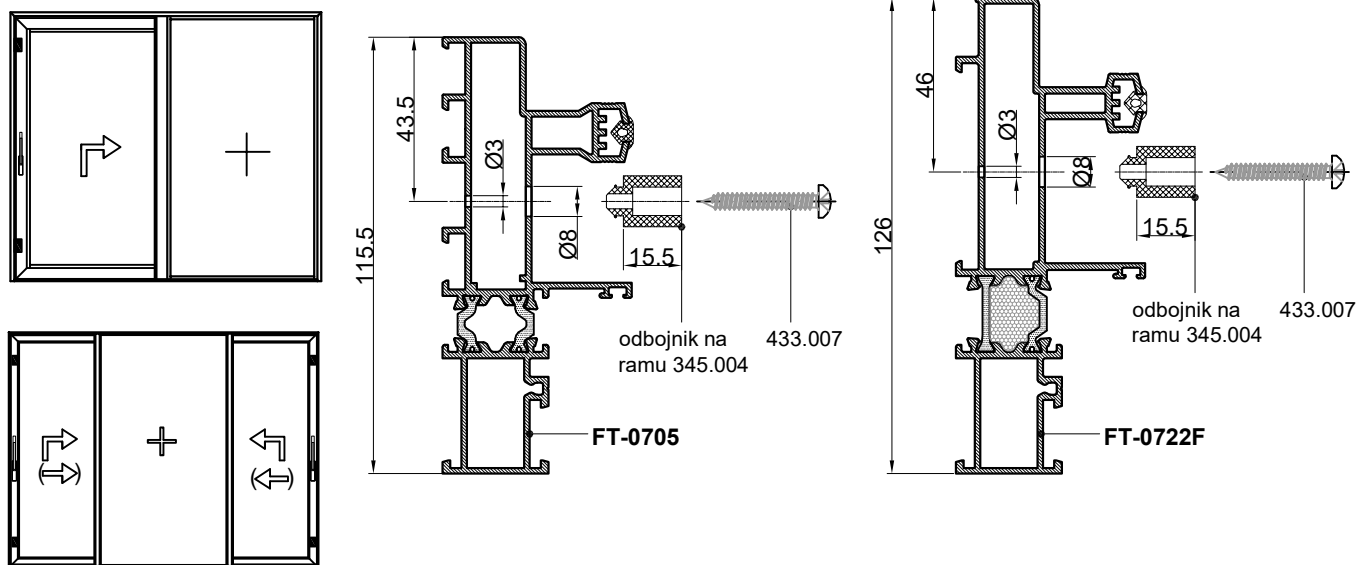

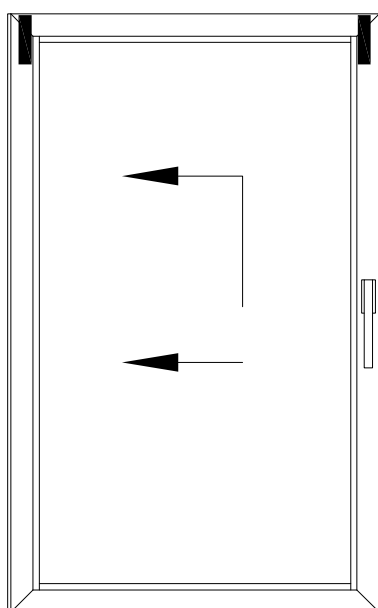
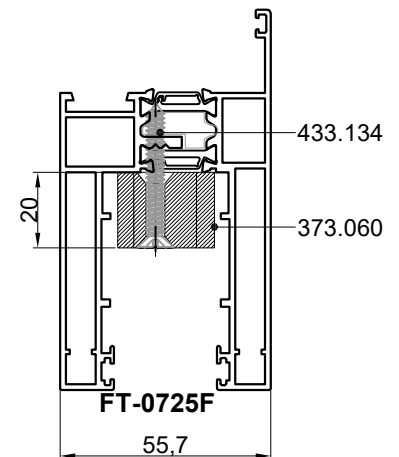
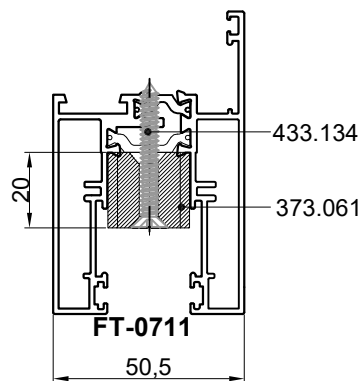
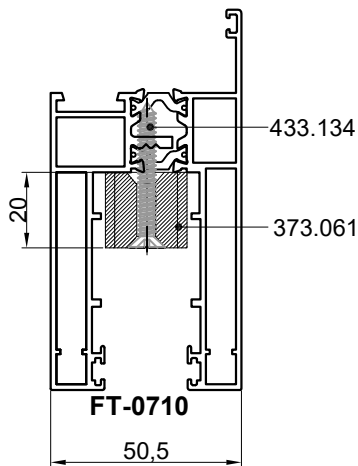
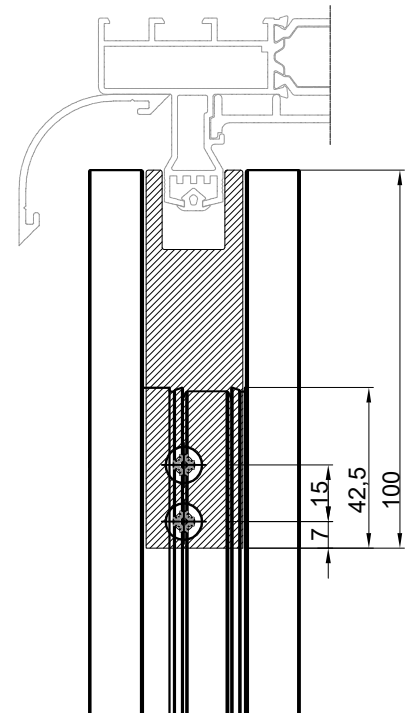
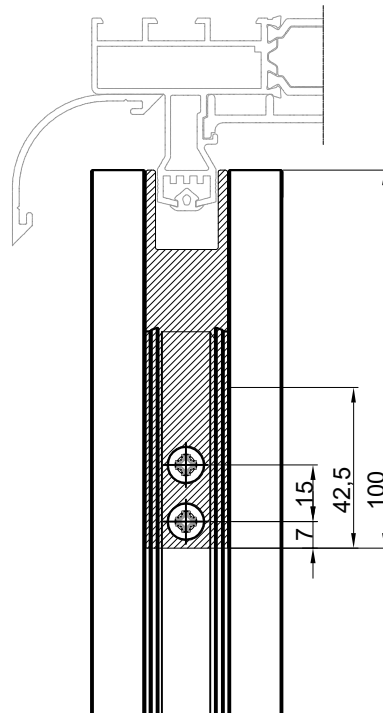
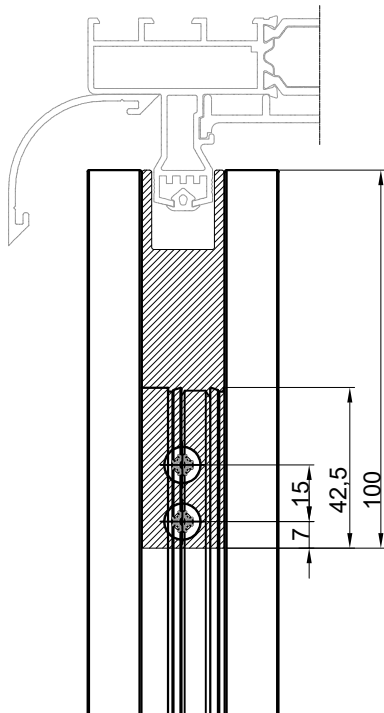

ukoliko brava podizno kliznog i kliznog mehanizma onemogućava ugradnju usmjerivača krila potrebno je skratiti na vrhu. (100 mm od vrha krila potrebno za ugradnju usmjerivača)

373.061.....usmjerivač za krila FT-0710 i FT-0711  
373.060.....usmjerivač za krila FT-0725F

- 2 kom. po krilu
- mogućnost ugradnje nakon postavljanja krila u ram
- koristiti za klizna i podizno klizna vrata

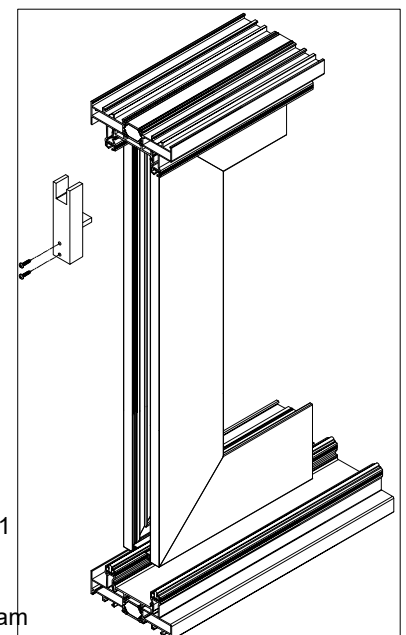

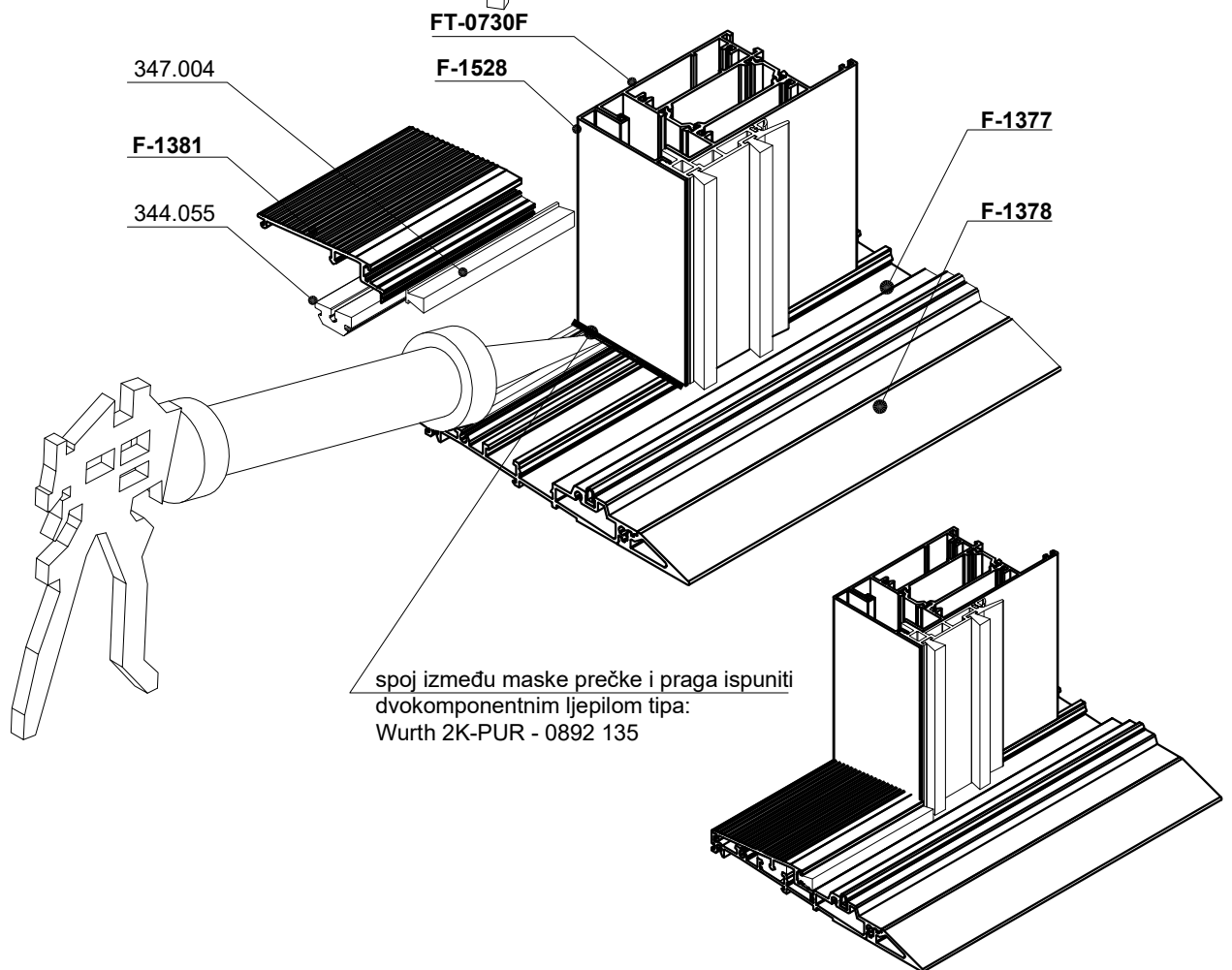
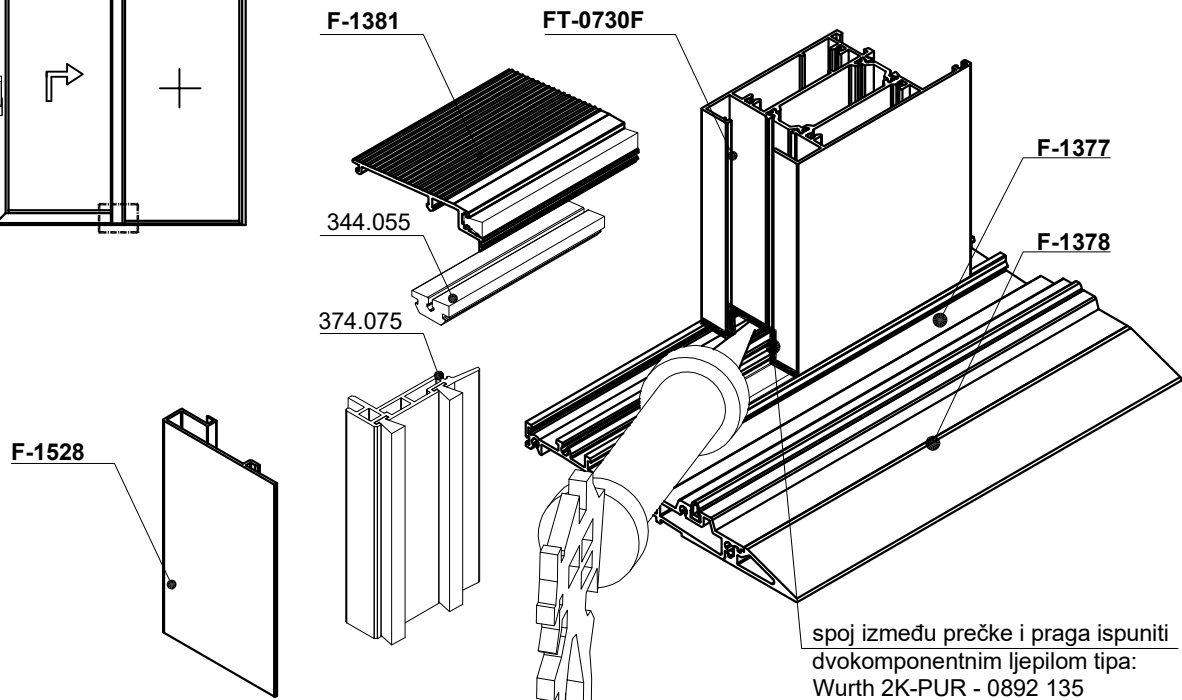
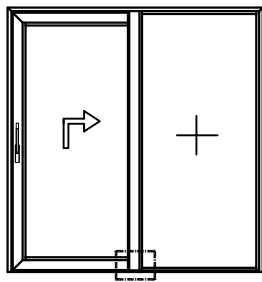

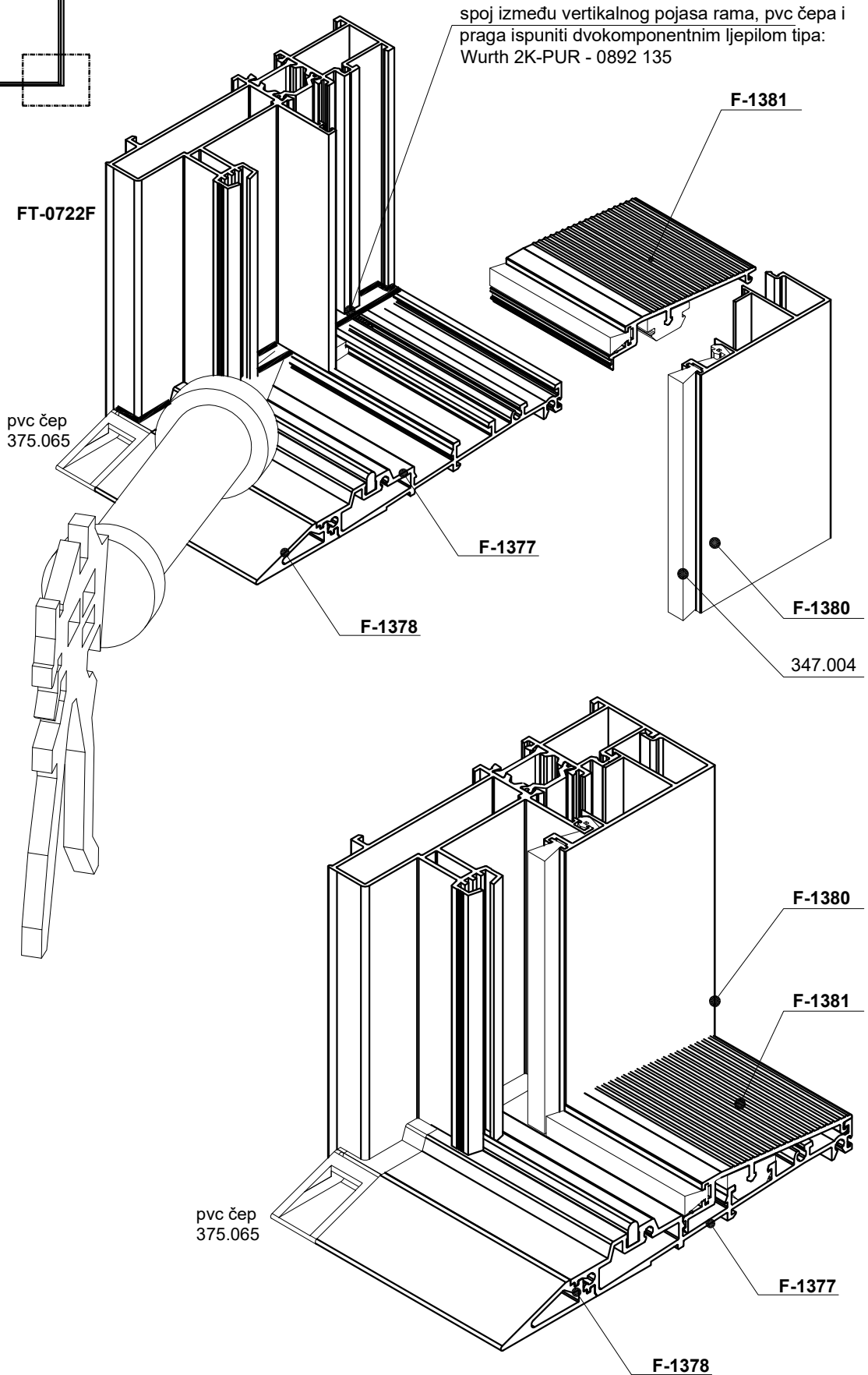
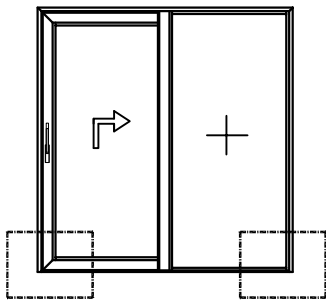

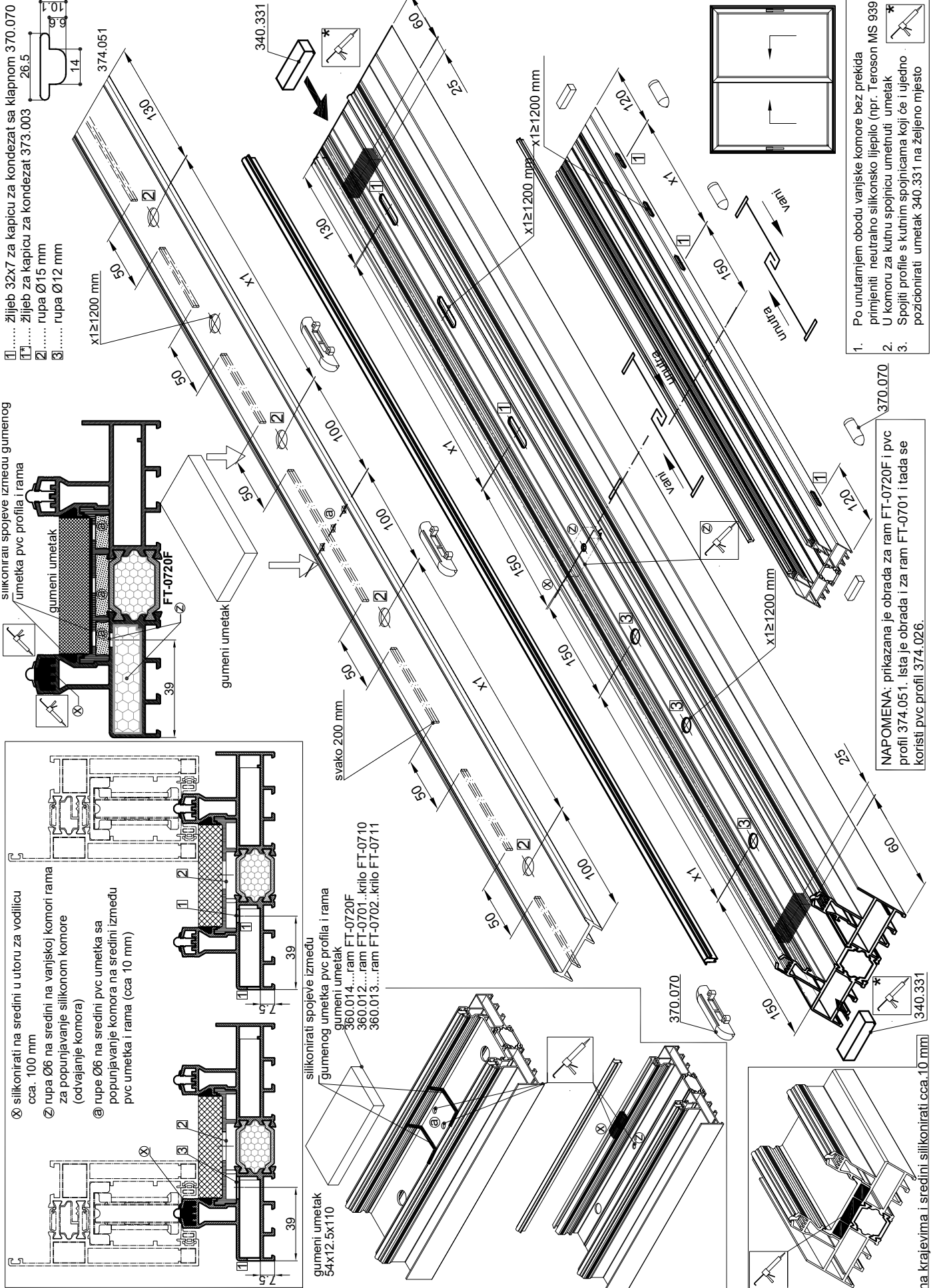







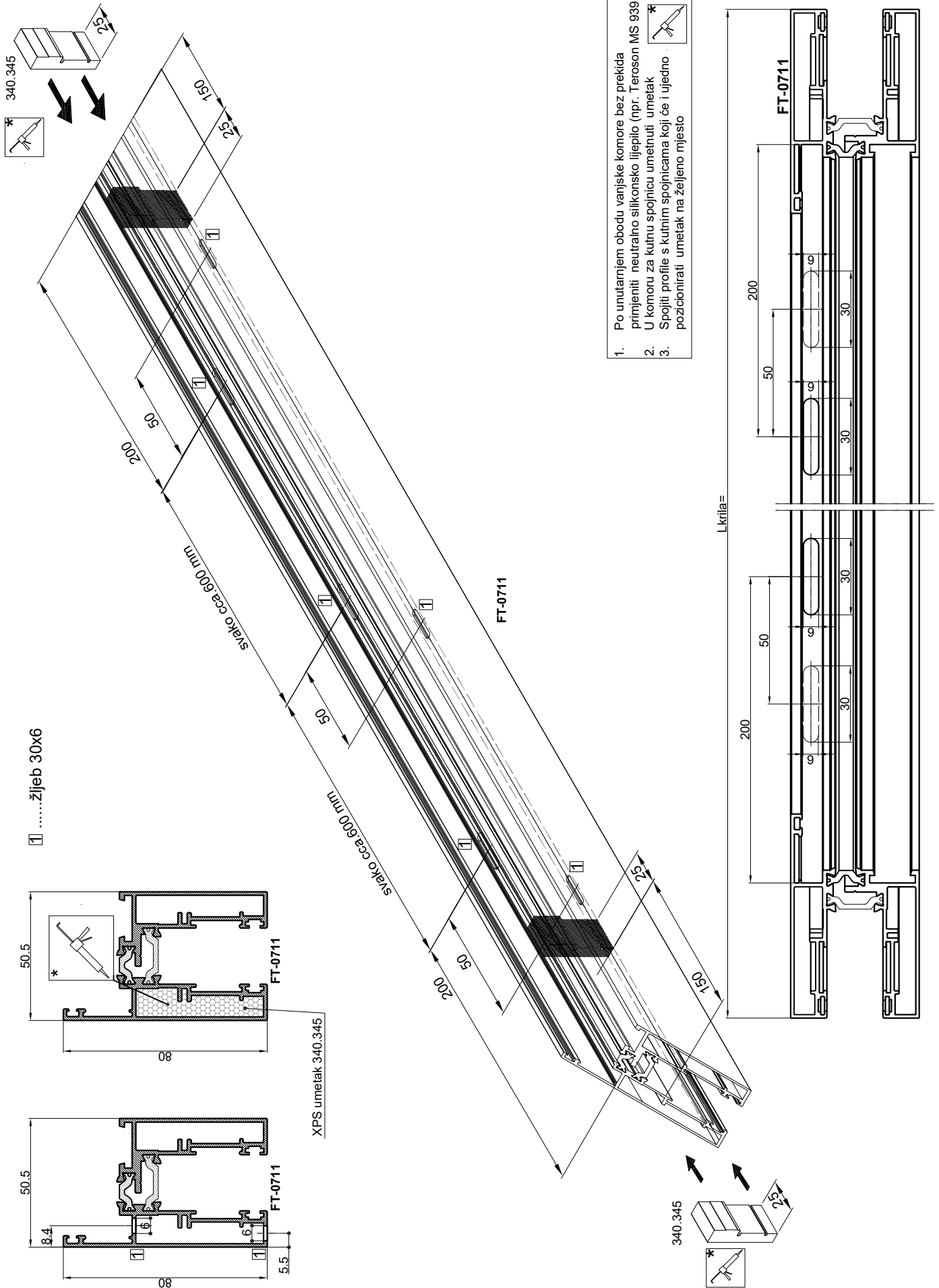

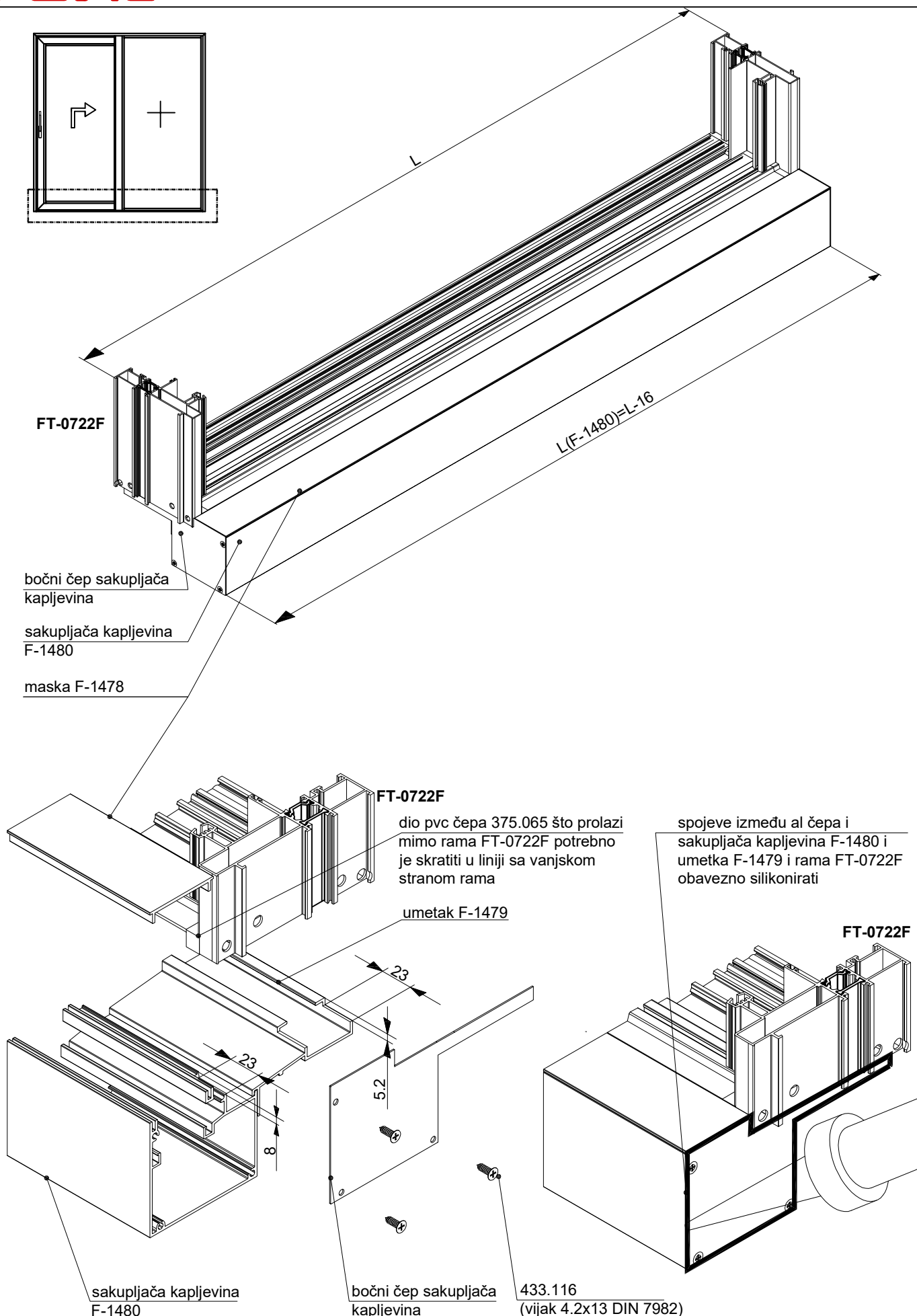

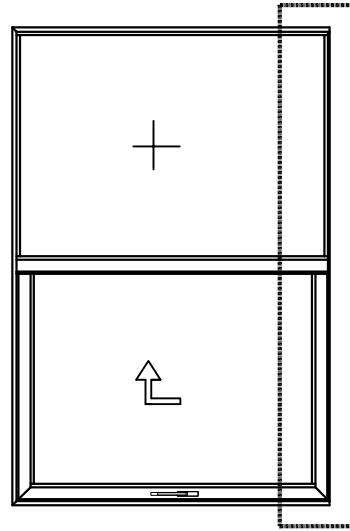
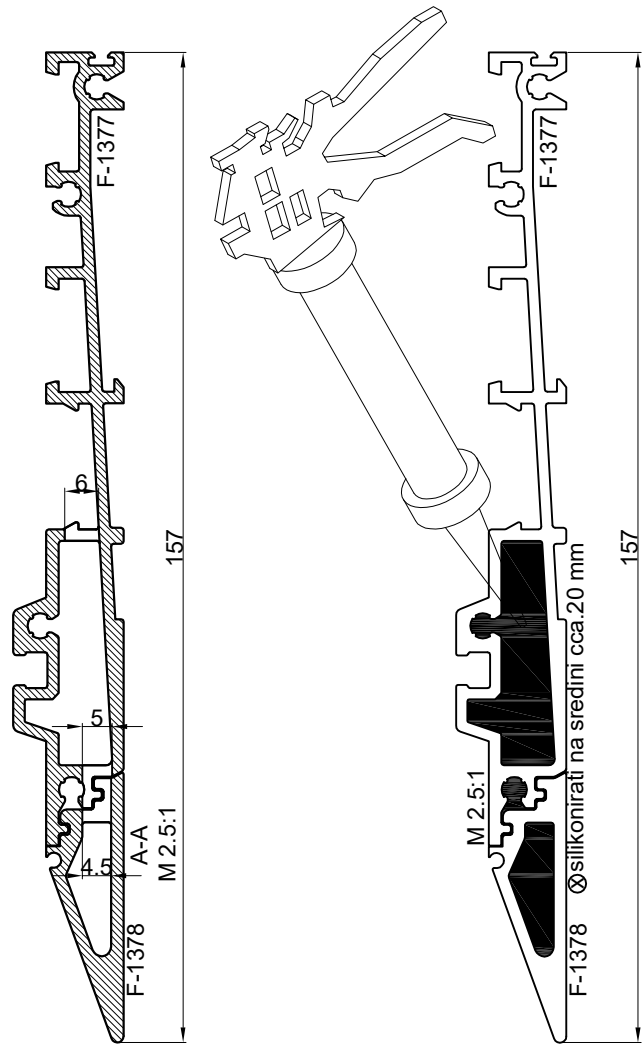
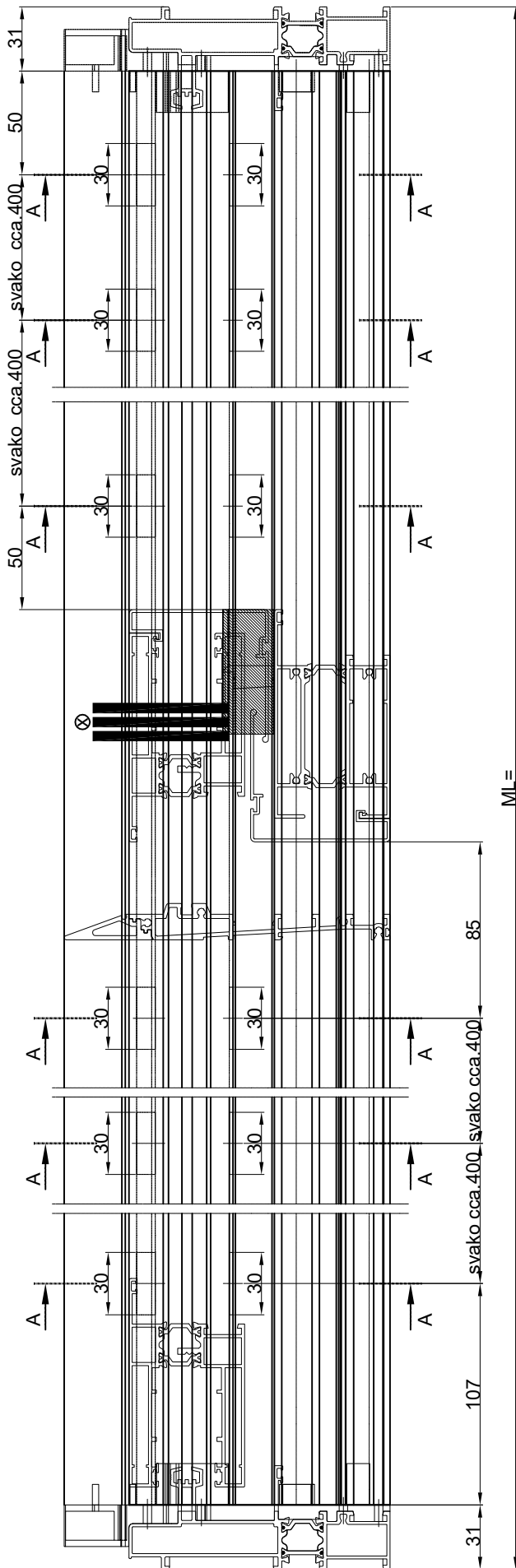

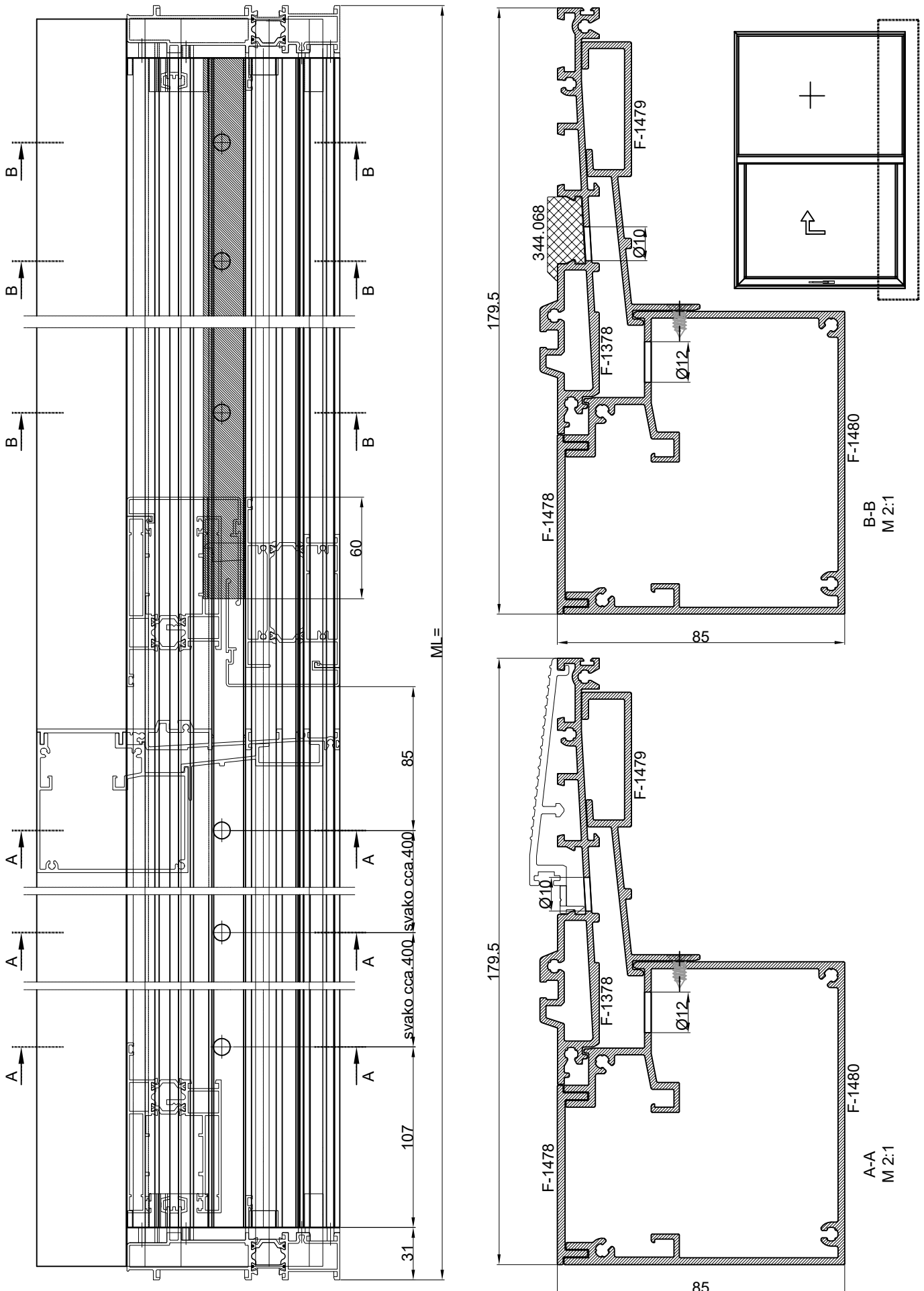

### 1. UGRADNJA KOTAČIĆA PODIZNO KLIZNOG MEHANIZMA HS-330

- kotačiće povezati spojnicom
- mjera pilanja spojnice je Lkr-640
- ugradnja pvc podmetača

### 1.OKOV HS 330- npr. Shema A (jedno krilo p.k+jedno fiksno)

- krilo FT-0710 i FT-0725F
- širina krila (Lkr) .....720-3235 mm
- visina krila (Hkr).....1200-2700 mm
- težina krila.....max.330 kg
- sa dodatnim kotačićima.....max.440 kg
- osa brave.....27.5 mm
- osa ručke.....1009 mm

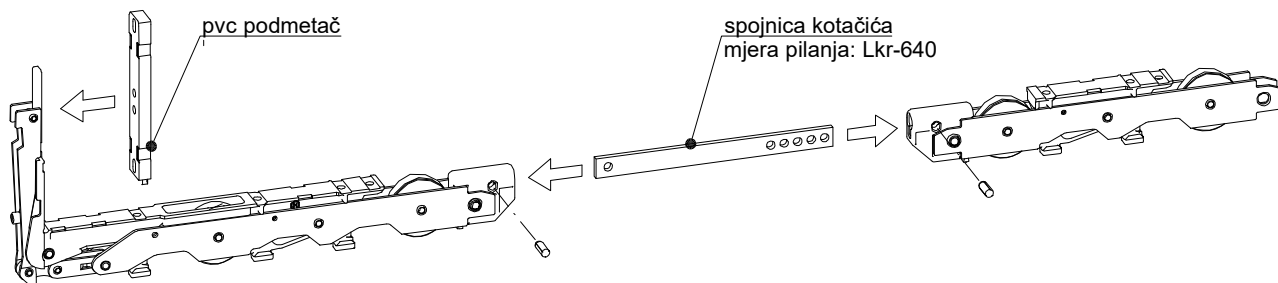

### 2. UGRADNJA KOTAČIĆA PODIZNO KLIZNOG MEHANIZMA HS-330 U KRILO

- ubaciti spojene kotačiće u krilo i fiksiranje

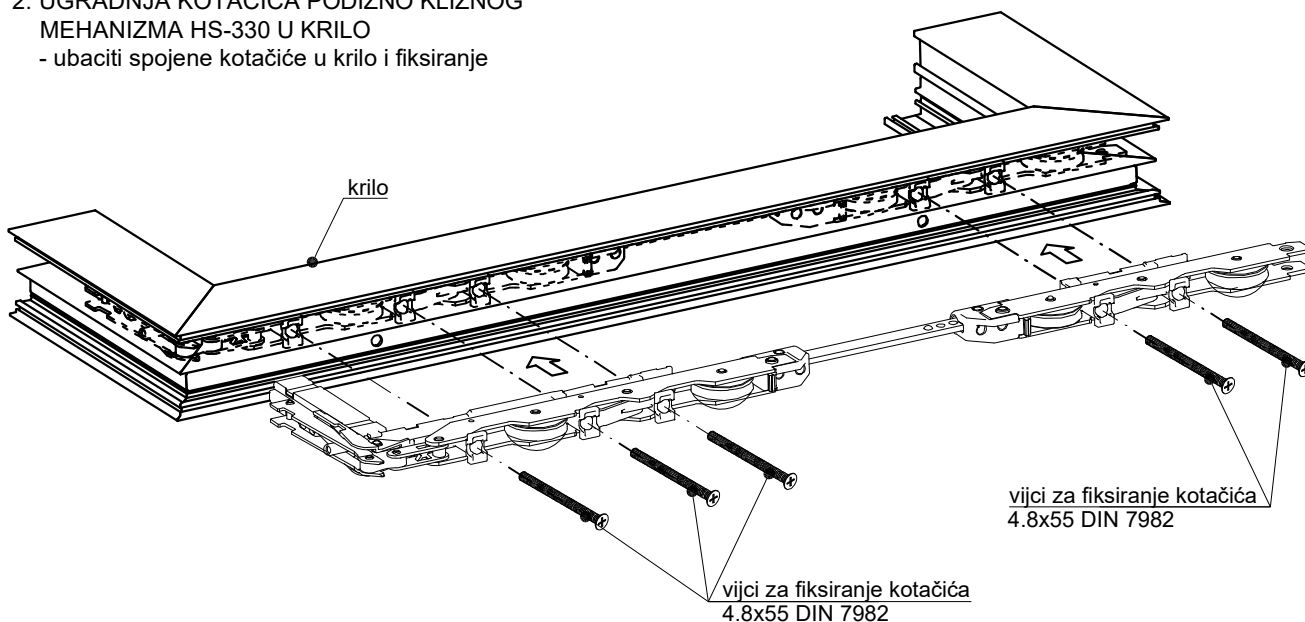

### 3. UGRADNJA KOTAČIĆA PODIZNO KLIZNOG MEHANIZMA HS-330 U KRILO

- fiksiranje kotačića i ugradnja odmaraca krila

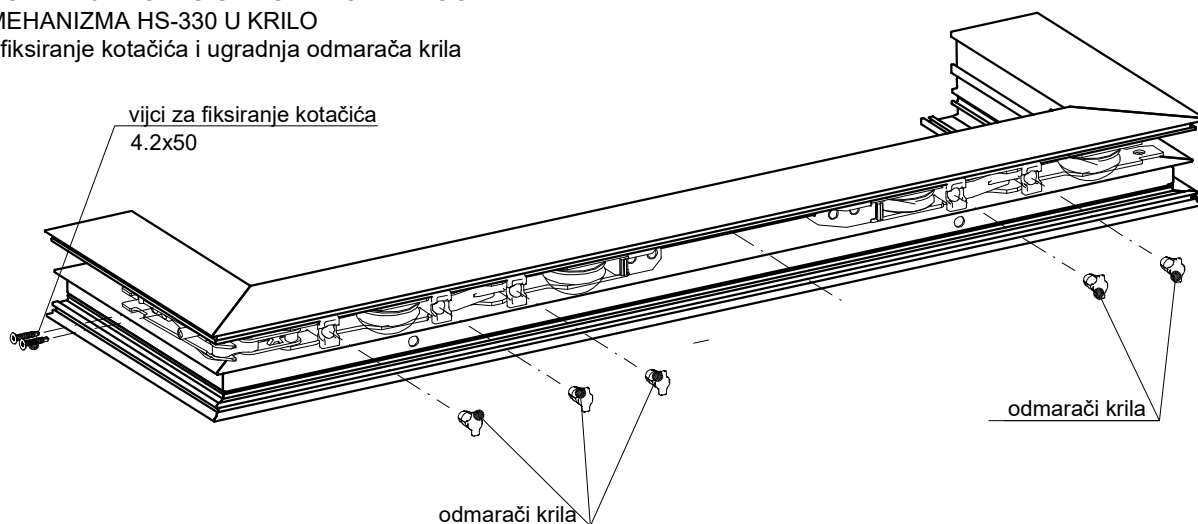

### 1. UGRADNJA BRAVE PODIZNO KLIZNOG MEHANIZMA HS-330

- skratiti bravu ovisno o visini krila
- mjera pilanja spojnice je Hkr-108
- ugradnja pvc podmetača
- ugradnja nastavka za krila veća od 2700 mm
- ugradnja brave u krilo

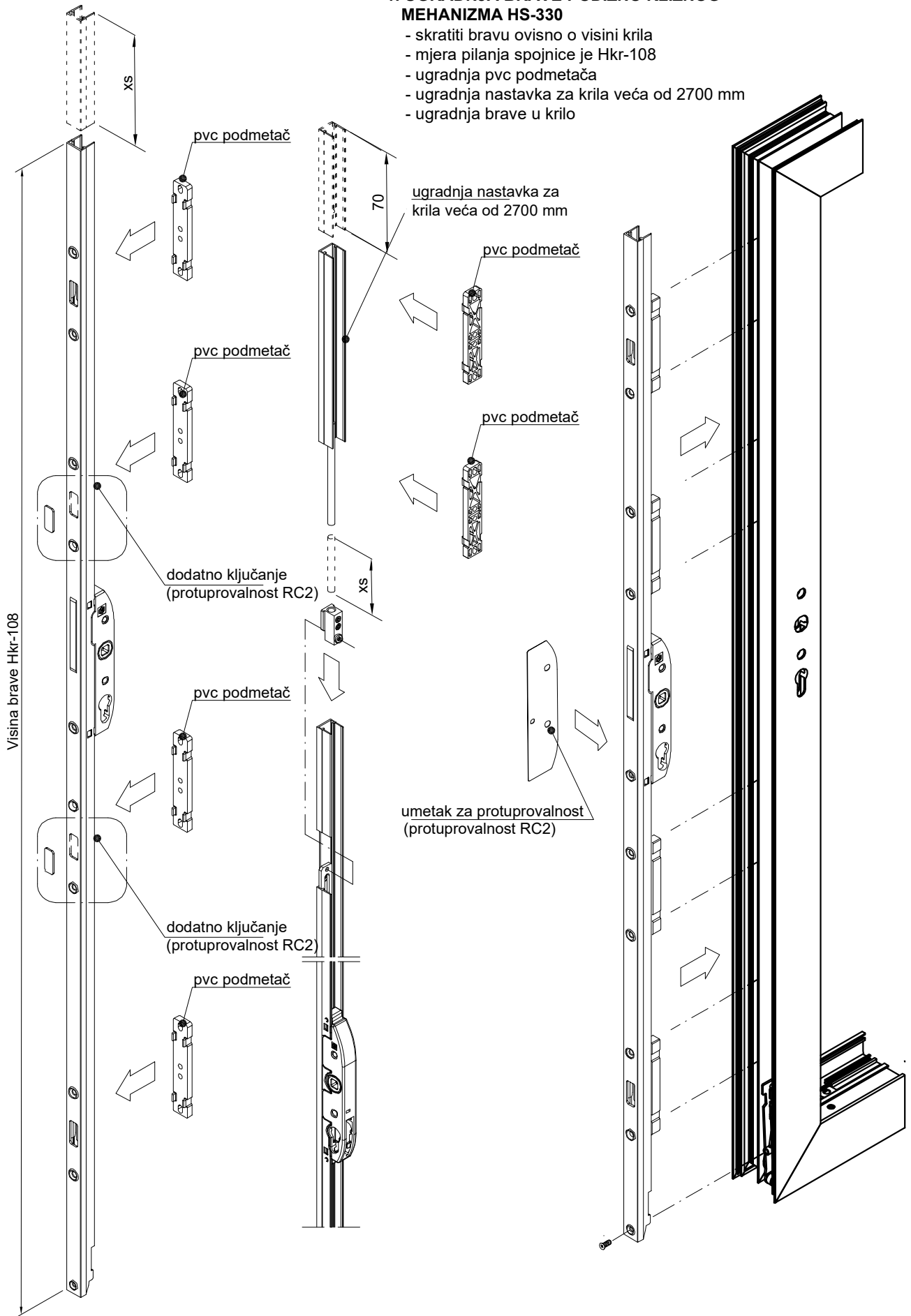

### 1. UGRADNJA BRAVE PODIZNO KLIZNOG MEHANIZMA HS-330

- pričvrstiti bravu vijcima 4.8x55 (upuštena glava)
- ugradnja ručke i prihvatnika

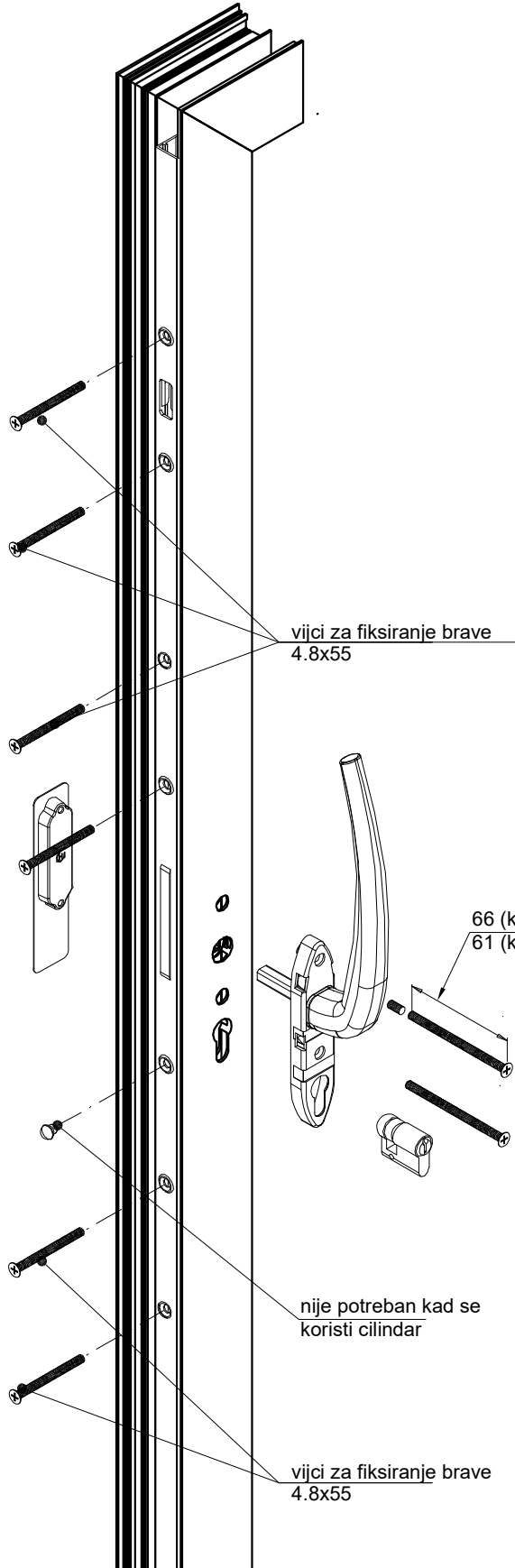

NAPOMENA: UKOLIKO SE KORISTI KLIZNI OKOV 149.039 OBRADA JE ISTA. (KRILO MOŽE BITI TEŽINE 330 kg)

### 2. Obrada krila

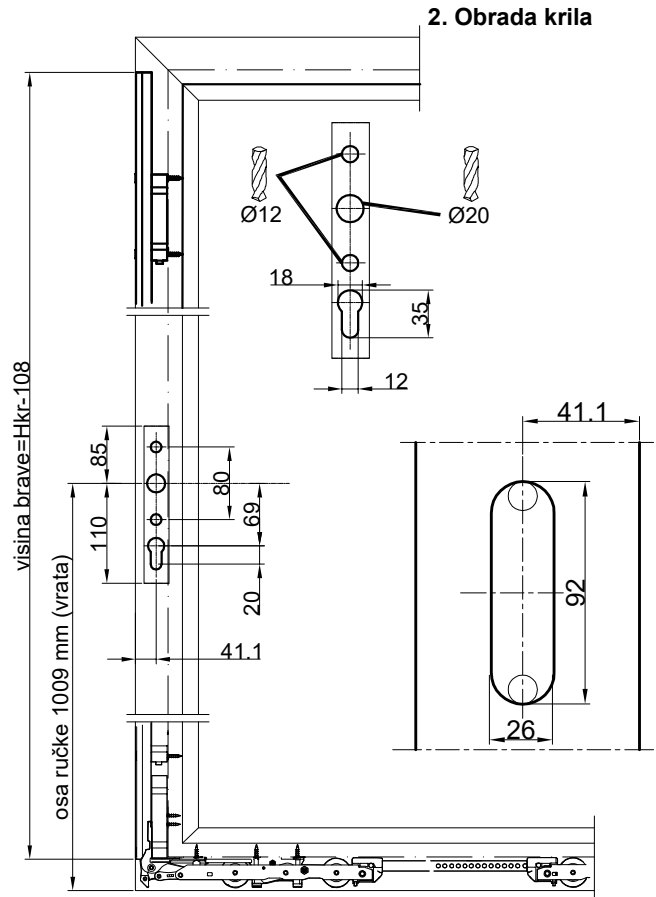

### 3. UGRADNJA KLJUČANJA NA RAMU

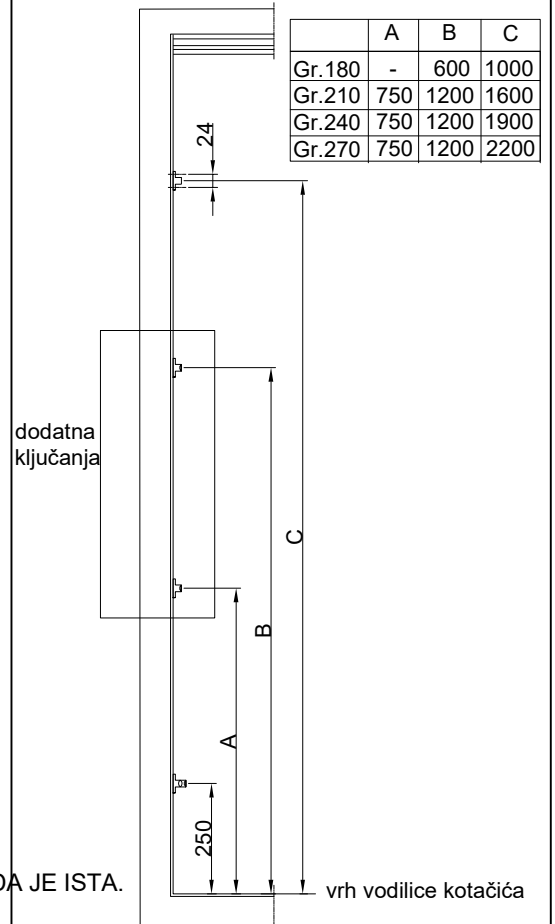

### 1.OKOV HS 120-krilo TI 939/940- npr.Schema A (jedno krilo p.k+jedno fiksno)

- krilo FT-0711
- širina krila (Lkr) .....650-2000 mm
- visina krila (Hkr).....1200-2400 mm
- težina krila.....max.120 kg
- osa brave.....25 mm
- osa ručke.....1005,5 mm-vrata
- osa ručke.....405.5 mm -prozor

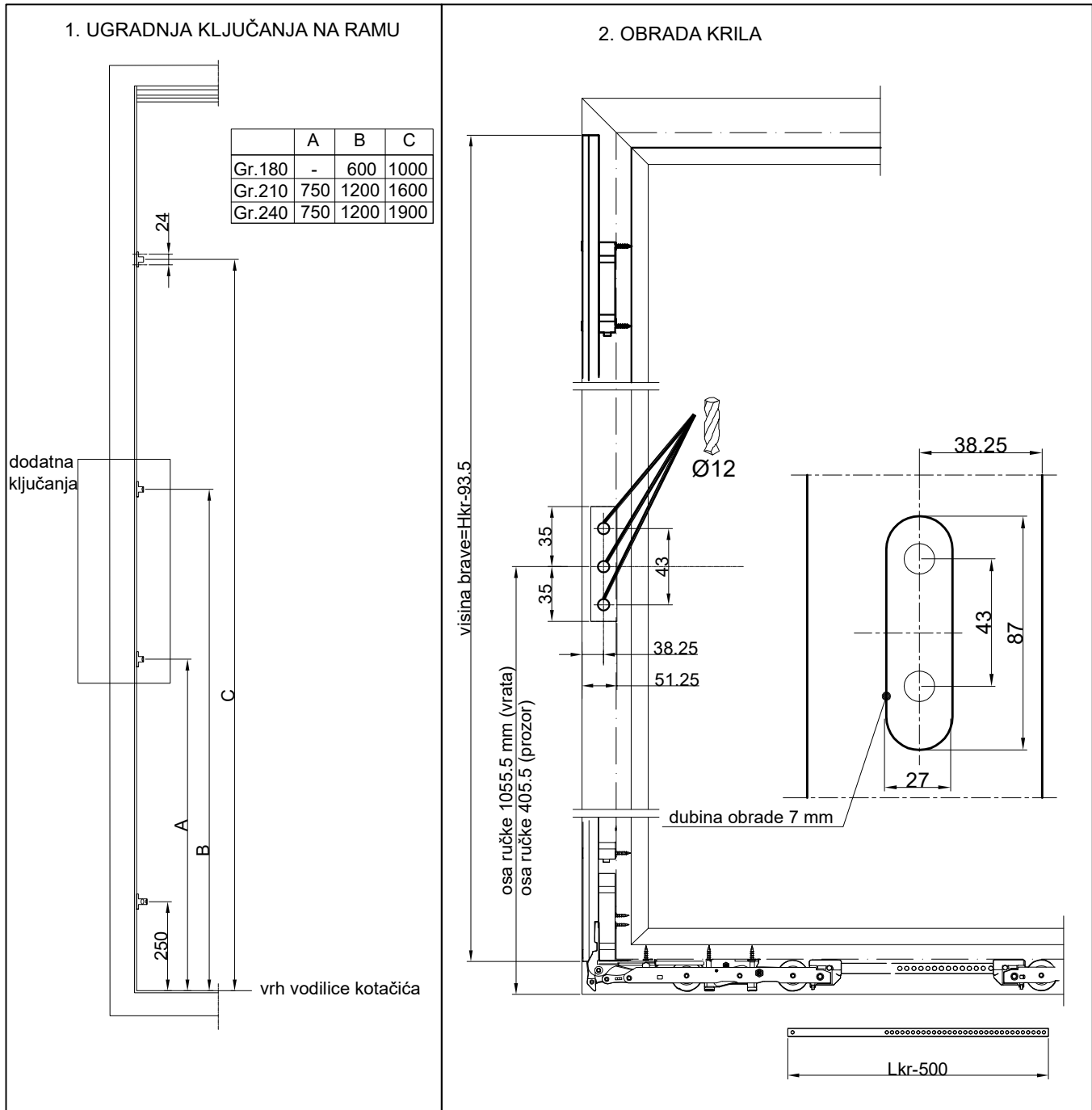

NAPOMENA: UKOLIKO SE KORISTI KLIZNI OKOV 149.040 OBRADA JE ISTA.  
(KRILO MOŽE BITI TEŽINE 200 kg)

- ukoliko je potrebno izvaditi kotačiće podiznog kliznog mehanizma potrebno je u naznačenoj poziciji detalj 1 skinuti profil maske F-1529 i pvc profil (374.075 za FT-0710 i 374.088 za FT-0711 i ukoliko unaprijed nije urađena obrada na krilu za vađenje brtve 347.011 obraditi krilo i izvući brtve, čime se omogućava vađenje kotačića.

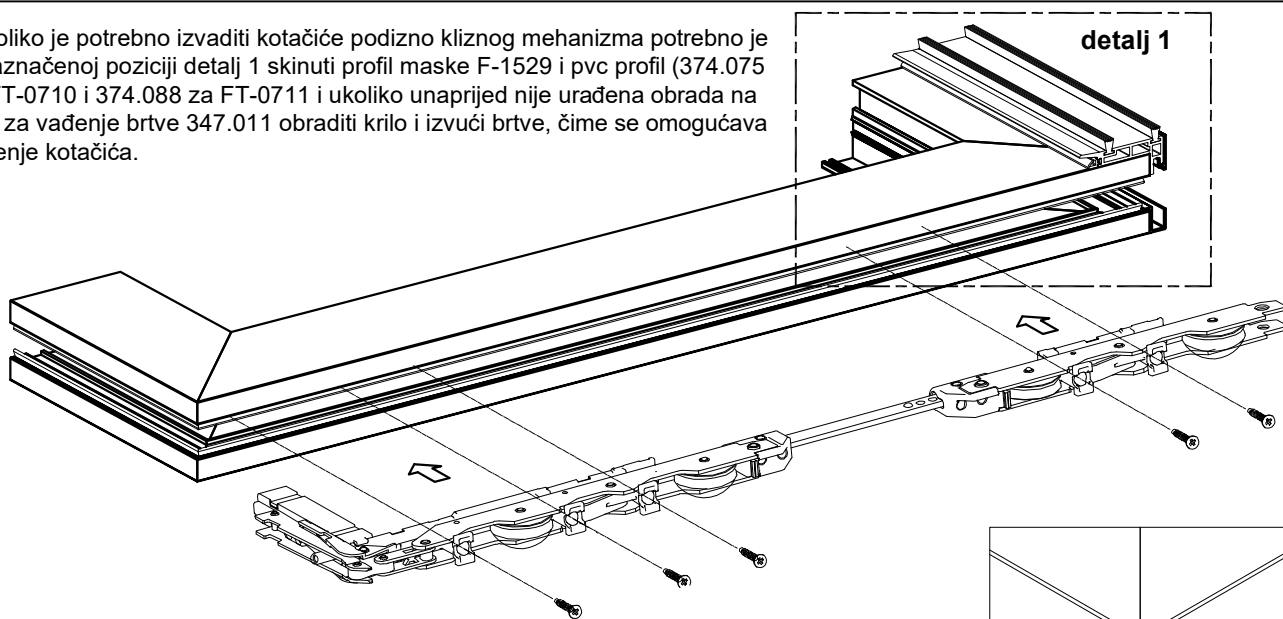

obrada na krilu koja omogućava vađenje brtve 347.011

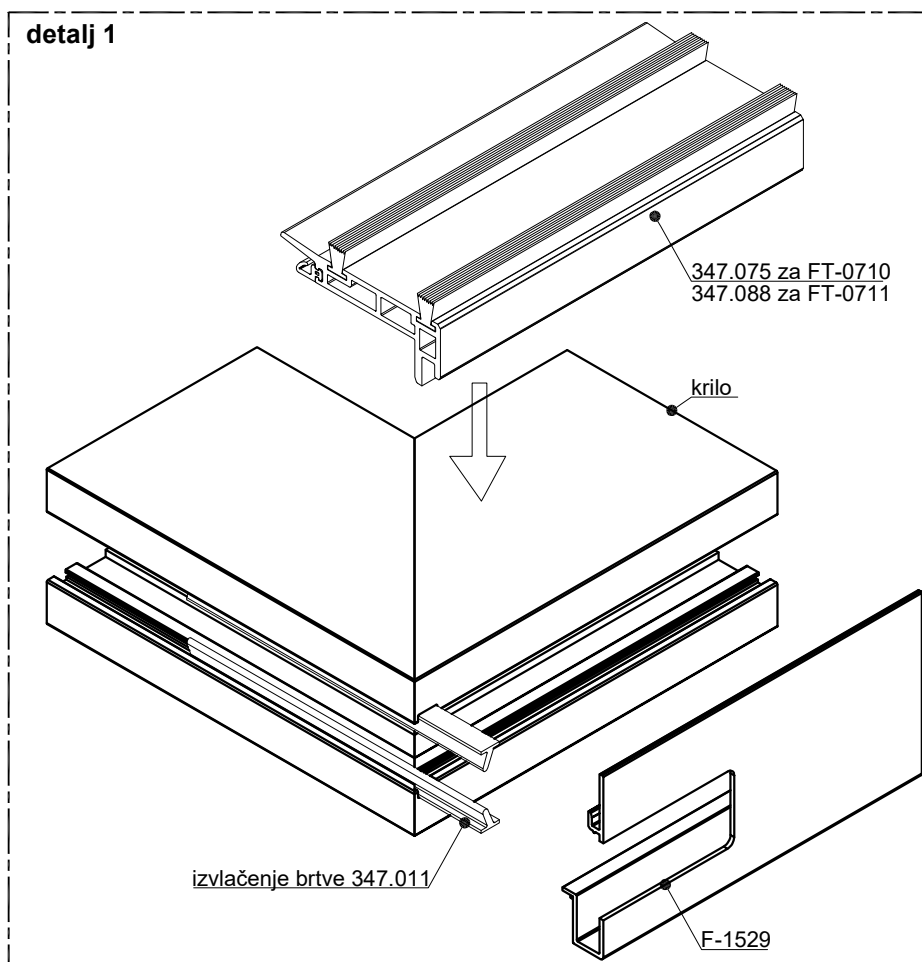
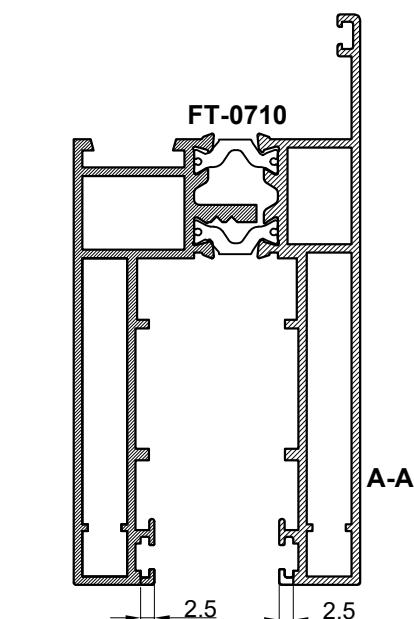
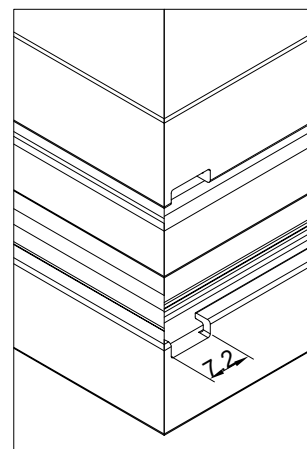
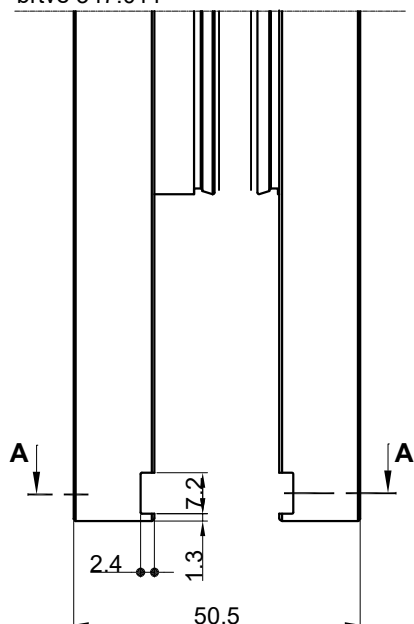

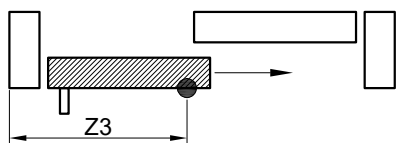
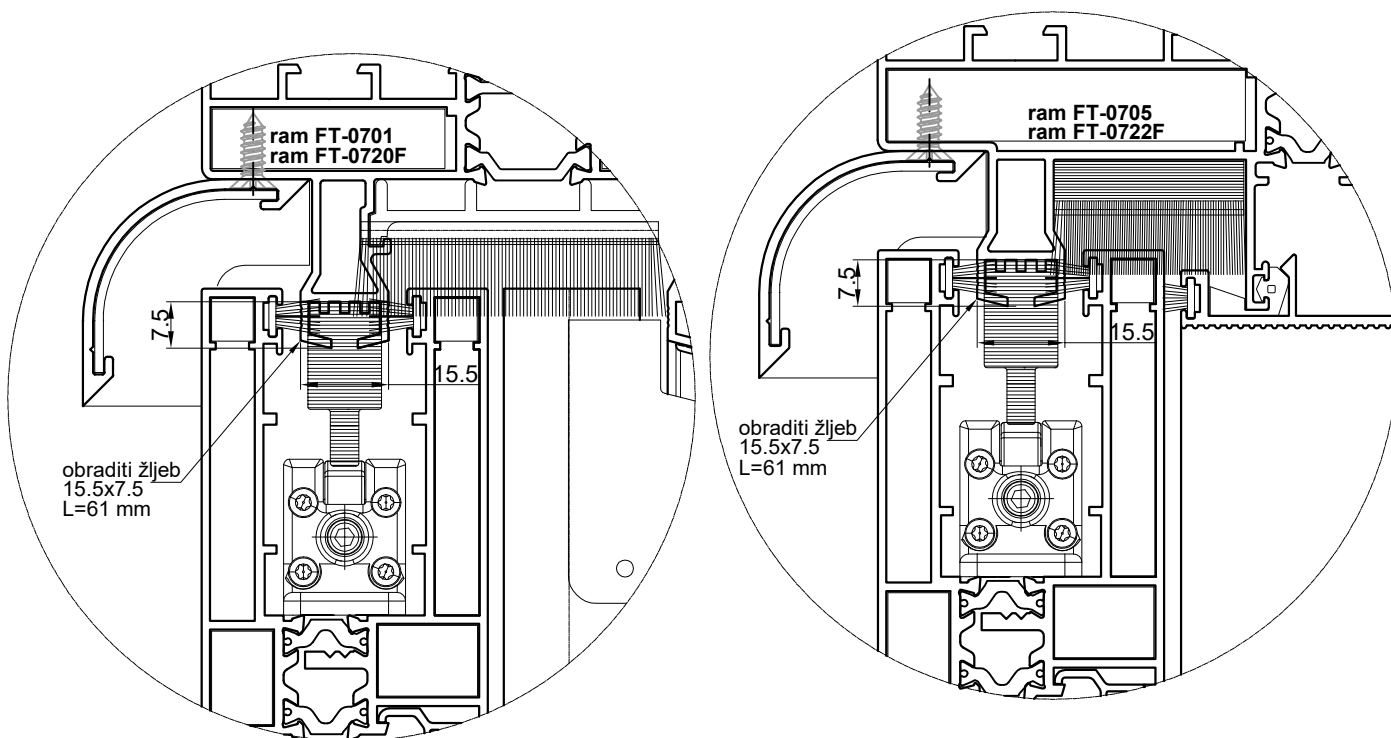

Z3= FB-69

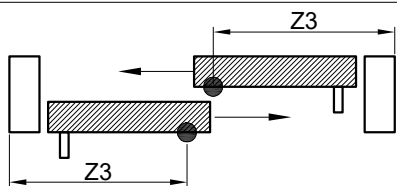
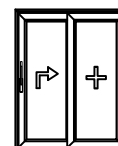

Z3= FB-69

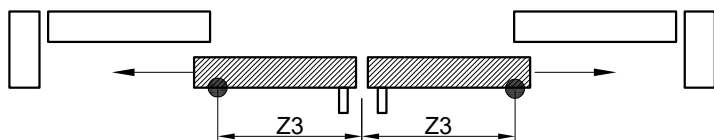
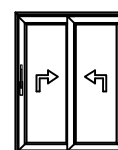

Z3= FB-107

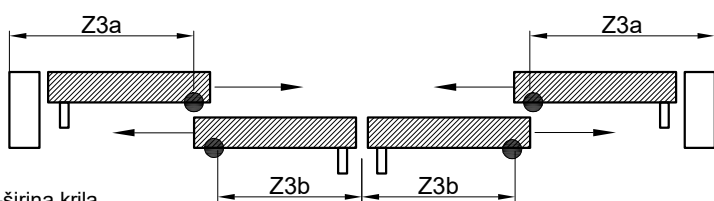
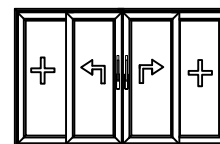

Z3a= FB-69  
Z3b= FB-107

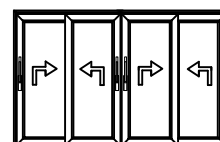

FB-širina krila

● pozicija usporivača (dio na ramu)...149.032

### MONTAŽA OPRUGE ZA LAGANO POKRETANJE RUČKE PODIZNO KLIZNOG MEHANIZMA

Opruga za težine krila  
 $\leq 200$  kg

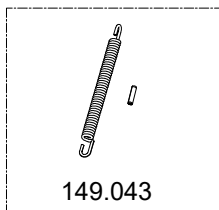

Opruga za težine krila  
 $> 200$  kg

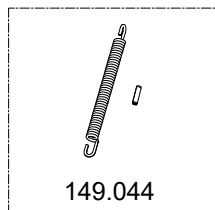

- A..... Postaviti bravu u dignuti položaj (otključano) (A.1/A.2).
- B..... Postaviti zatik u određeni položaj na bravi (već postoji rupa na bravi)
- C..... Position tension spring within the espag.
- D..... Povuci kraj zatezne opruge preko zuba na bravi (pomoću odvijača) (D.1/D.2).
- E..... Ispravno namontirana opruga

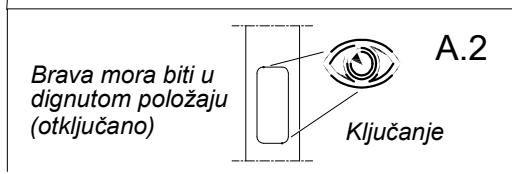
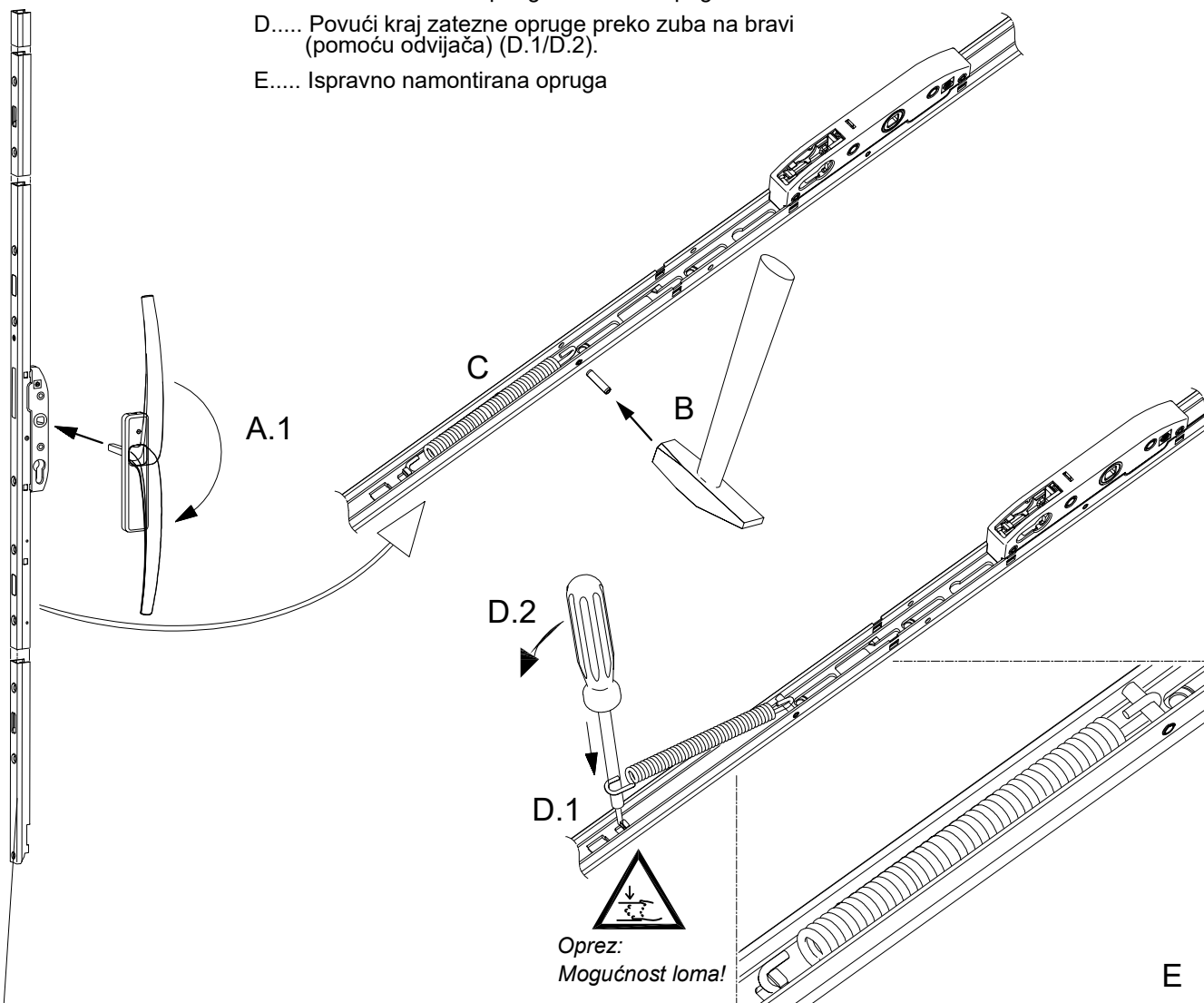

FT-0710

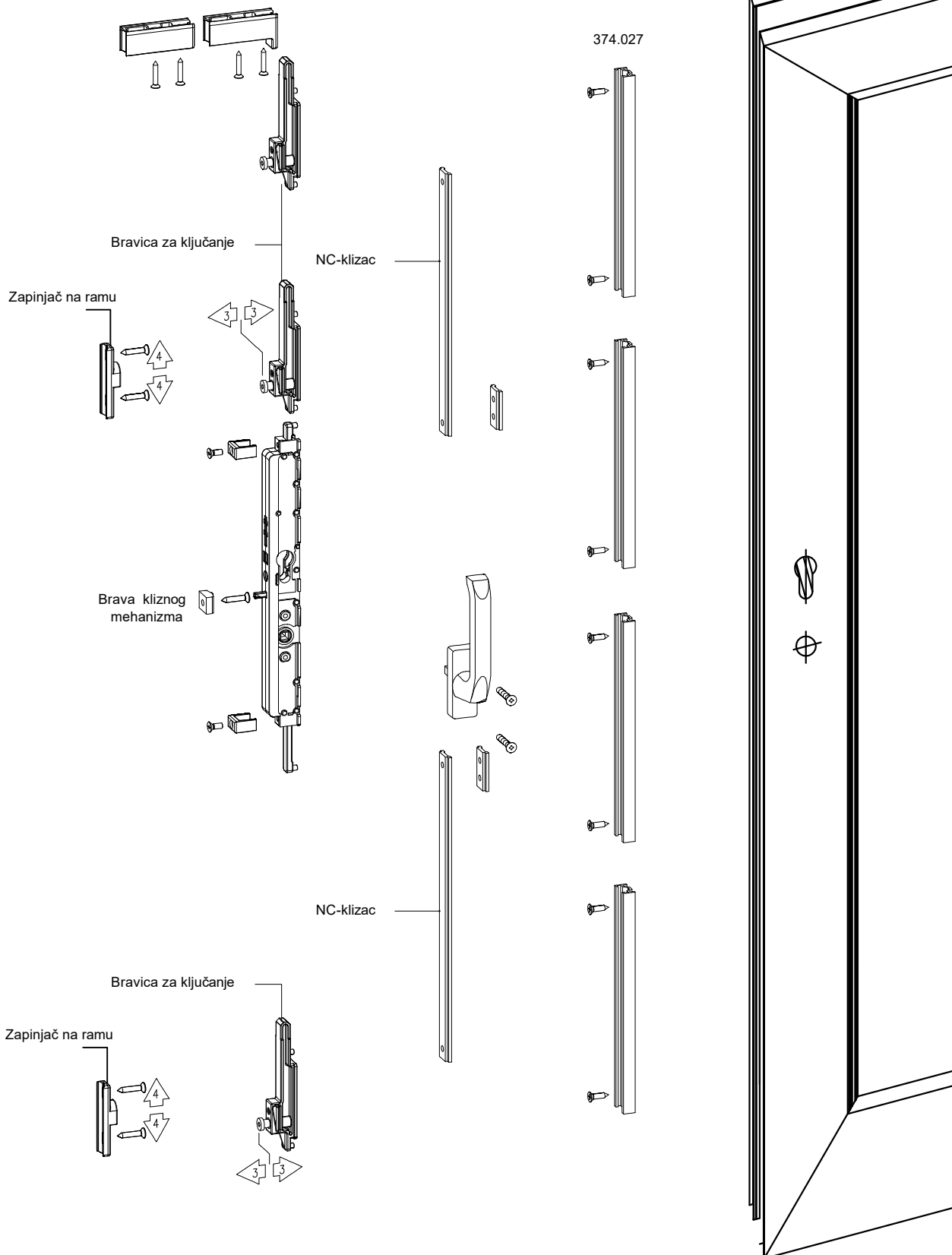

### Izrezivanje termo štapića (poliamida) radi kompeziranja širenja profila

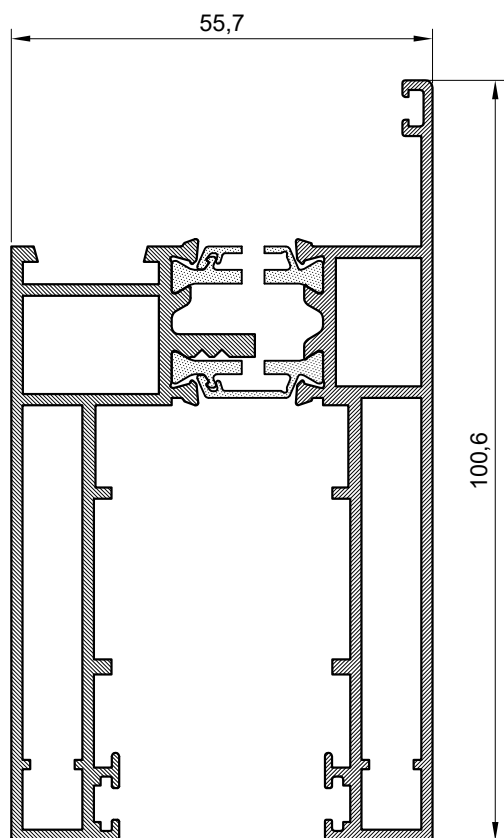

**FT-0725F**

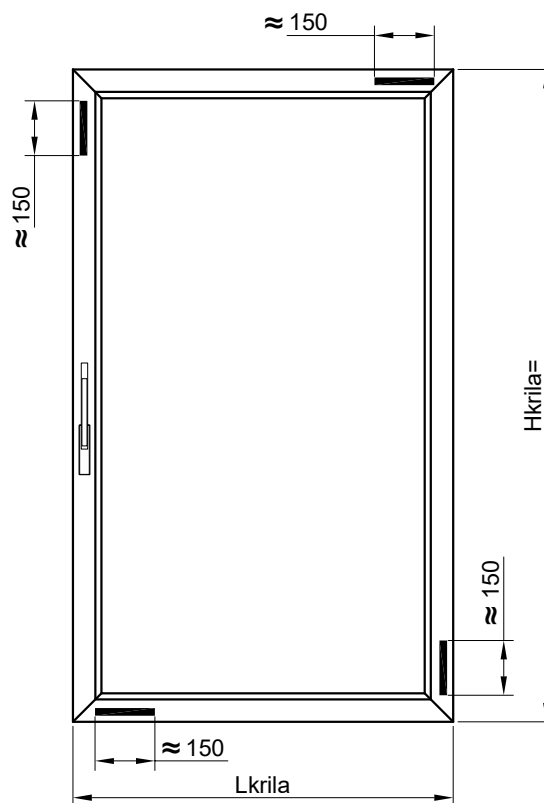

— Pozicija izrezivanja termo štapića (poliamida) na krilu  $\approx 150$  mm

Izrezati termo štapiće (poliamide) cca. 150 mm

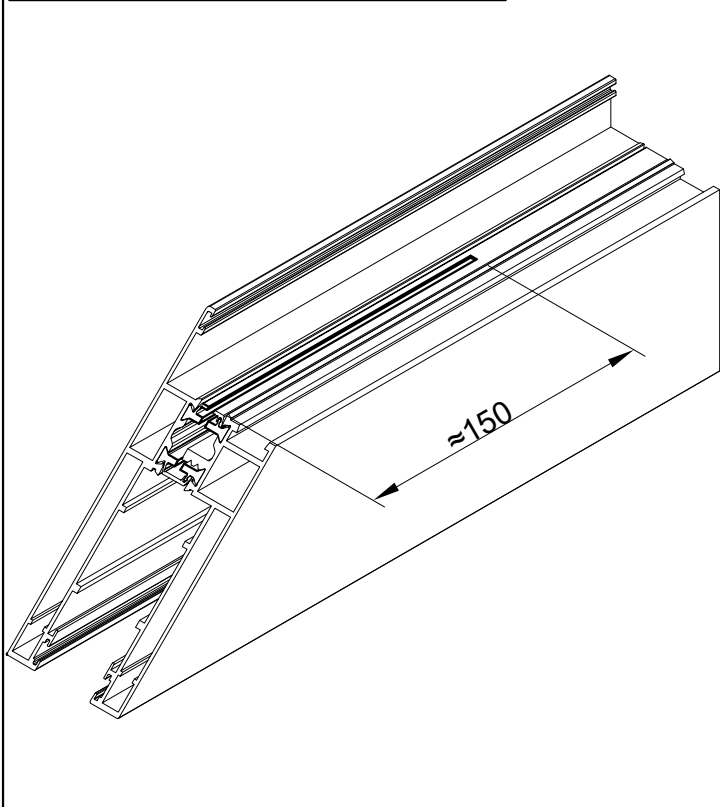

Naljepiti jednostrano ljepljivu traku na mjestu reza termo štapića (poliamida)

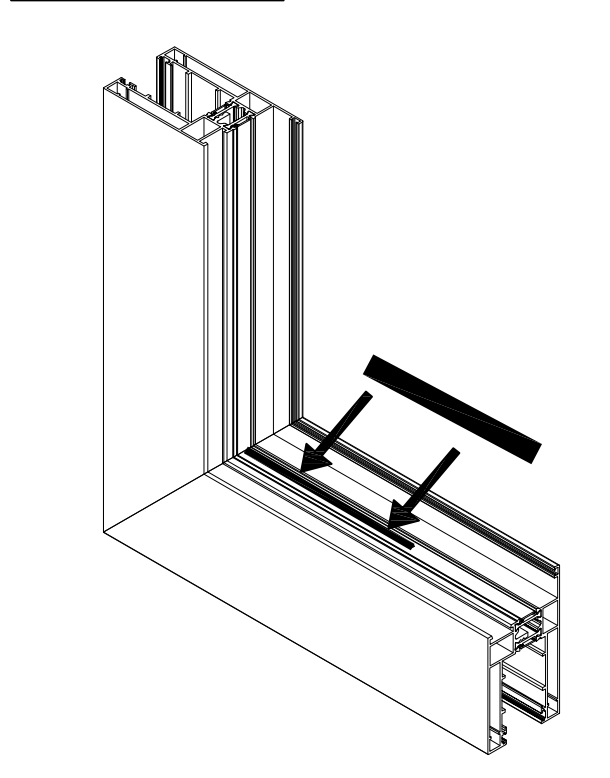

**Diletacija pvc profila: 374.026 (Termo 120)  
374.051 (Termo 120-D)**

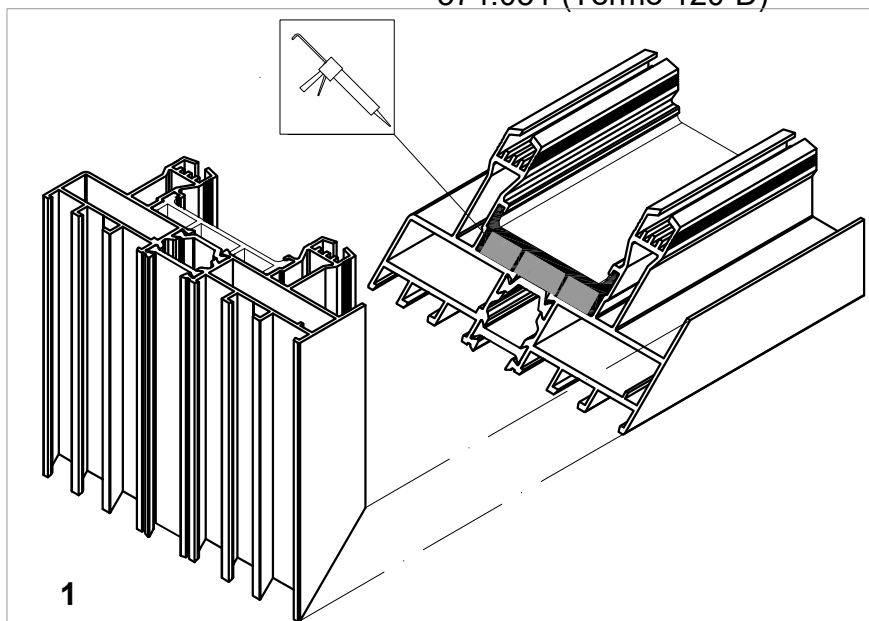
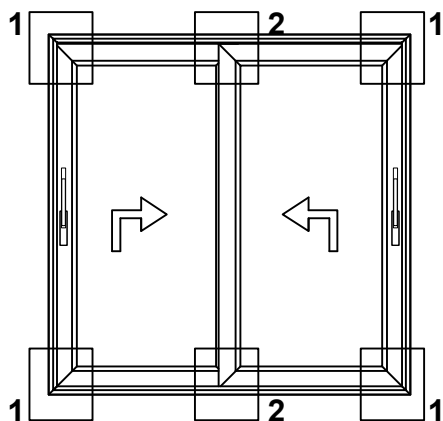

**1**

- Sve površine koje se spajaju-rezove očistiti i odmastiti odgovarajućim sredstvom /npr. "Henkel" - Teroson VR 20 ili Teroson FL+ /.
- Sve površine koje se spajaju (dodirne površine rama i pvc profila) premazati /npr. "Henkel" - Teroson VR 20 ili Teroson FL+ /.
- Ljepilo također ubrizgati u komore između pvc profila i rama cca.10-15 mm
- Nakon spajanja profila, sve spojeve profila i umetka ispuniti ljepljivom za metal /npr. "Henkel" - Teroson MS 939 /.
- Dio ljepljive koji iscure između rezova očistiti sredstvom za čišćenje i odmašćivanje /npr. "Henkel" - Teroson VR 20 ili Teroson FL+ /.

**2**

- pvc profil u rami (na poz.2) razdvojiti cca. 10 mm zbog diletacije pvc profila (u donjoj zoni ispod gumenog umetka u hornjoj zoni između četkica)

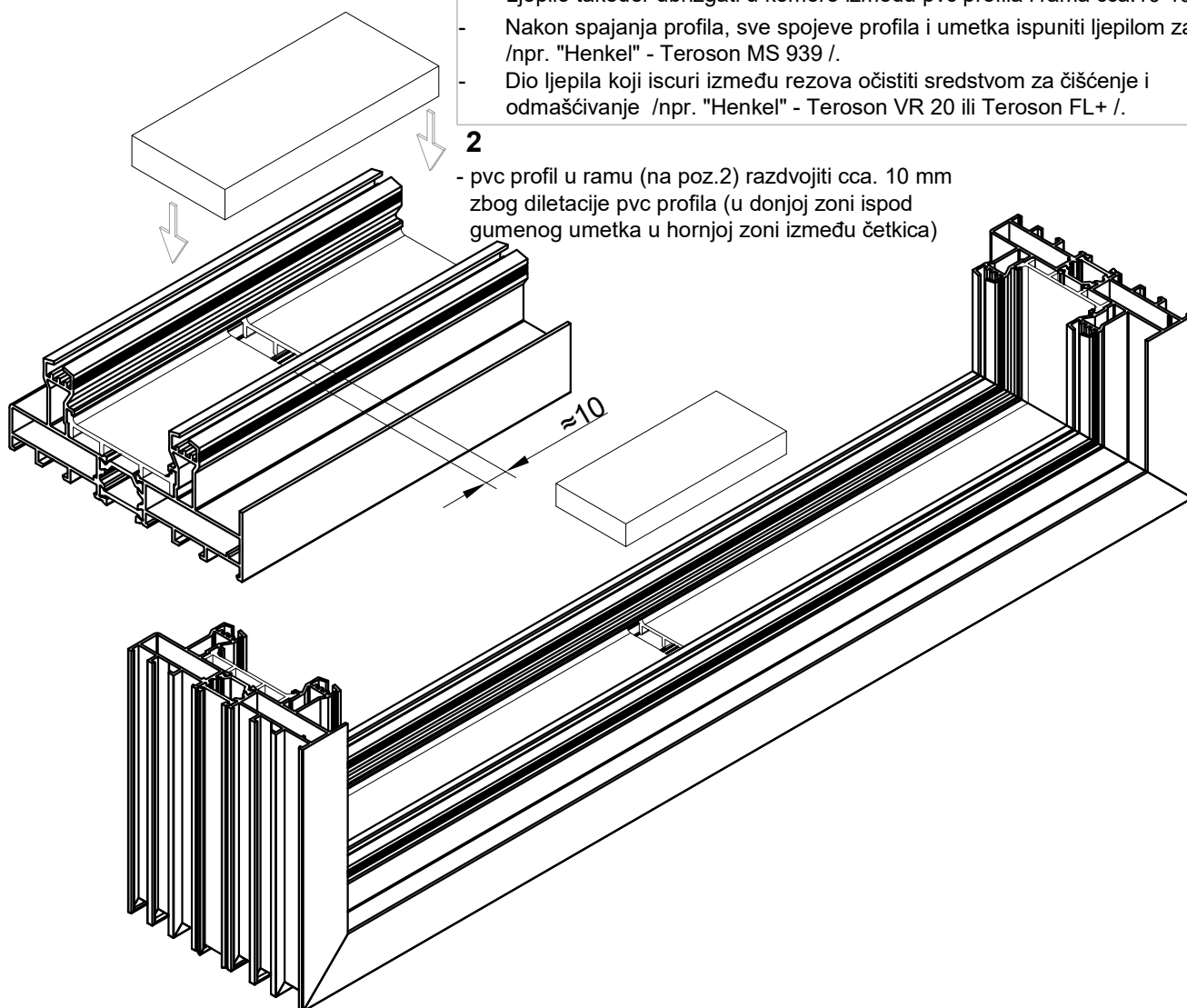

## Ugradnja profila: FT-0718 (Termo 120) FT-0734F (Termo 120-D)

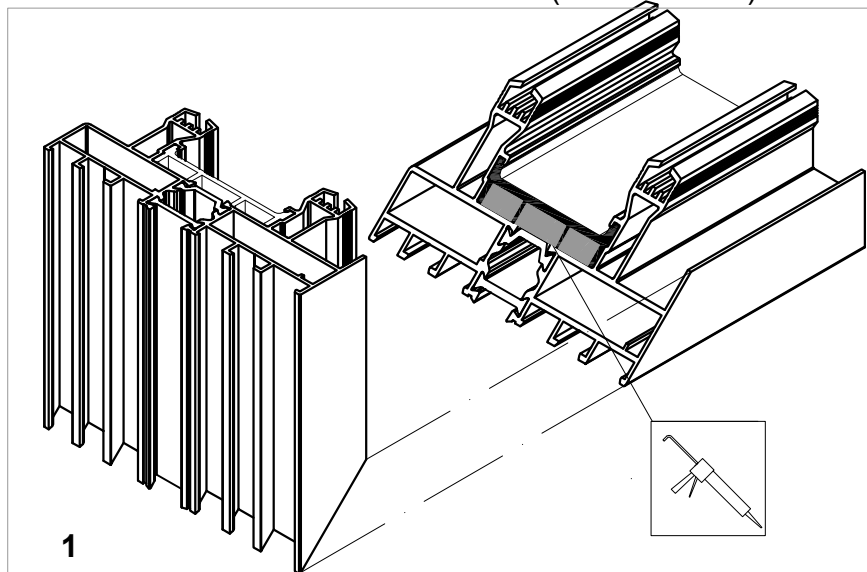
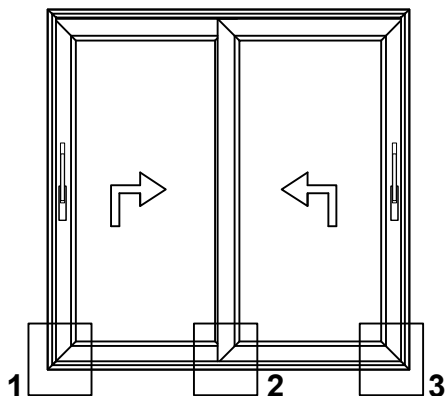

**1**

- Sve površine koje se spajaju-rezove očistiti i odmastiti odgovarajućim sredstvom /npr. "Henkel" - Teroson VR 20 ili Teroson FL+ /.
- Sve površine koje se spajaju (dodirne površine rama i pvc profila) premazati /npr. "Henkel" - Teroson VR 20 ili Teroson FL+ /.
- Ljepilo također ubrizgati u komore između pvc profila i rama cca.10-15 mm
- Nakon spajanja profila, sve spojeve profila i umetka ispuniti ljepilom za metal /npr. "Henkel" - Teroson MS 939 /.
- Dio ljepila koji iscuri između rezova očistiti sredstvom za čišćenje i odmašćivanje /npr. "Henkel" - Teroson VR 20 ili Teroson FL+ /.

**3**  
silikonirati spoj između al umetka (FT-0718 ili FT-0734F) i rama po cijeloj dužini kao i spoj sa verikalnim pvc profilom u rami.

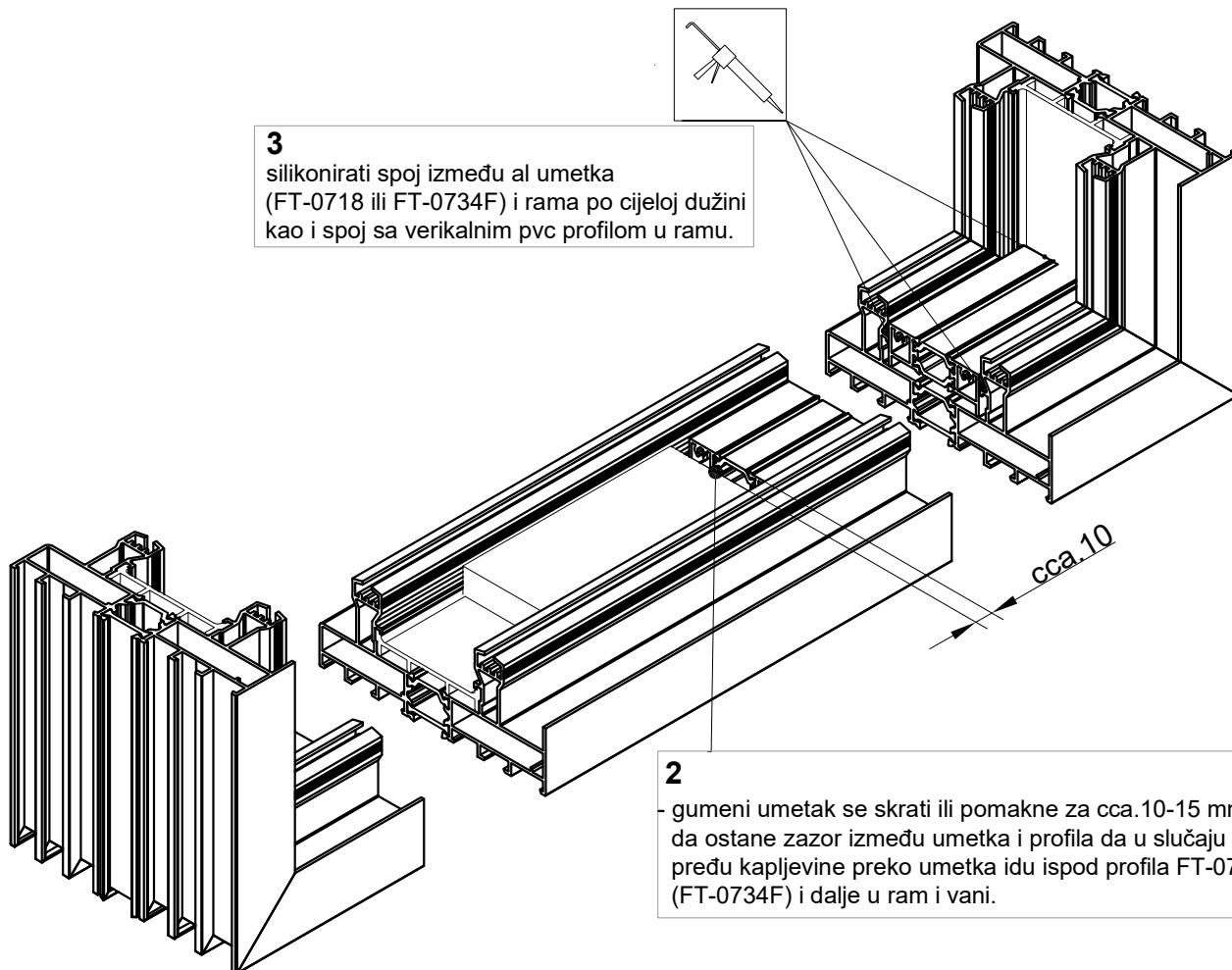

**2**

- gumeni umetak se skрати ili pomakne za cca.10-15 mm da ostane zazor između umetka i profila da u slučaju da pređu kapljavine preko umetka idu ispod profila FT-0718 (FT-0734F) i dalje u ram i vani.



# Rezne liste



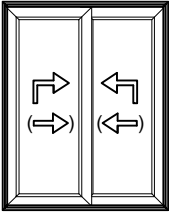

Profili Termo 120		Profili Termo 120-D		mjera	kom.	pilanje
Ram FT-0701	.....	Ram FT-0720F	.....	ML	2	45-45
Ram FT-0701	.....	Ram FT-0720F	.....	MH	2	45-45
Krilo FT-0710	.....	Krilo FT-0725F	.....	ML/2+2	4	45-45
Krilo FT-0710	.....	Krilo FT-0725F	.....	Hkr (NAP.1)	4	45-45
Lajsna F-1529	.....	Lajsna F-1528	.....	Hkr	2	90-90
Maska vanjska F-1231	.....	Maska vanjska F-1231	.....	ML-44.5	1	90-90
Staklo lajsna Z40-665	.....	Staklo lajsna Z40-660	.....	Lkr-157.2	4	90-90
Staklo lajsna Z40-665	.....	Staklo lajsna Z40-660	.....	Hkr-201	4	90-90
		Držač točkića F-1676	.....	Lkr-50	2	90-90
Kutna spojnica 710.445	.....				8	
Kutna spojnica 710.504	.....				8	
Kutna spojnica 710.011	.....				16	
Kutna spojnica 730.013	.....				8	
Kutna spojnica 730.001	.....				24	
Čep maske krila 375.016	.....				4	
Odbojnik 375.020	.....				2	
Čep profila maske F-1231 375.018	.....				1 par	
Čep za odvod vode 370.070	.....				2	
Usmjerivač krila 373.061(**)	.....				4	
Usmjerivač krila 373.060***	.....				4	
Umetak sa četkicom 340.007*	.....				2	
Umetak sa četkicom 340.007**	.....				1	
Umetak sa četkicom 340.046***	.....				1	
Gumeni umetak 360.012**	.....				1	
Gumeni umetak 360.014***	.....				1	
Izolacijski umetak 340.044***	.....				2Hkr	
Brtva prema staklu vanjska 321.002 (staklo 24 mm* i **)	.....			Hkr	4	
Brtva prema staklu vanjska 321.002 (staklo 24 mm* i **)	.....			Lkr	4	
Brtva prema staklu unutarnja 311.003 (staklo 24 mm* i **)	.....			Hkr	4	
Brtva prema staklu unutarnja 311.003 (staklo 24 mm* i **)	.....			Lkr	4	
Brtva prema staklu 311.001 (staklo 44 mm***)	.....			Hkr	8	
Brtva prema staklu 311.001 (staklo 44 mm***)	.....			Lkr	8	
Brtva vertikalnog pojasa krila 347.012	.....			Hkr	2	
Brtva u krilu 347.011**	.....			4Lkr+4Hkr		
Brtva u krilu 347.012***	.....			8Lkr+4Hkr		
Četkica u krilu 347.004*	.....			8Lkr+4Hkr		
Četkica u krilu 347.004**	.....			4Lkr		
Brtva na spoju dva krila 347.003	.....			4Hkr		
Brtva u ramu 344.052	.....			2ML+4MH		
PVC profil 374.026* i **	.....			MH-40.5	2	45-45
PVC profil 374.026* i **	.....			ML-40.5	2	45-45
PVC profil 374.051***	.....			MH-40.5	2	45-45
PVC profil 374.051***	.....			ML-40.5	2	45-45
PVC profil 374.075	.....			Hkr	2	90-90
PVC podmetač kotačića 374.042* i **	.....			L=200 mm	4	90-90
PVC podmetač kotačića 374.052***	.....			L=200 mm	4	90-90
Al vodilica F-1112	.....			ML-104	2	90-90
PVC podmetač brave 374.028* i **	.....			Hkr	2	90-90
PVC podmetač brave 374.060***	.....			Hkr	2	90-90

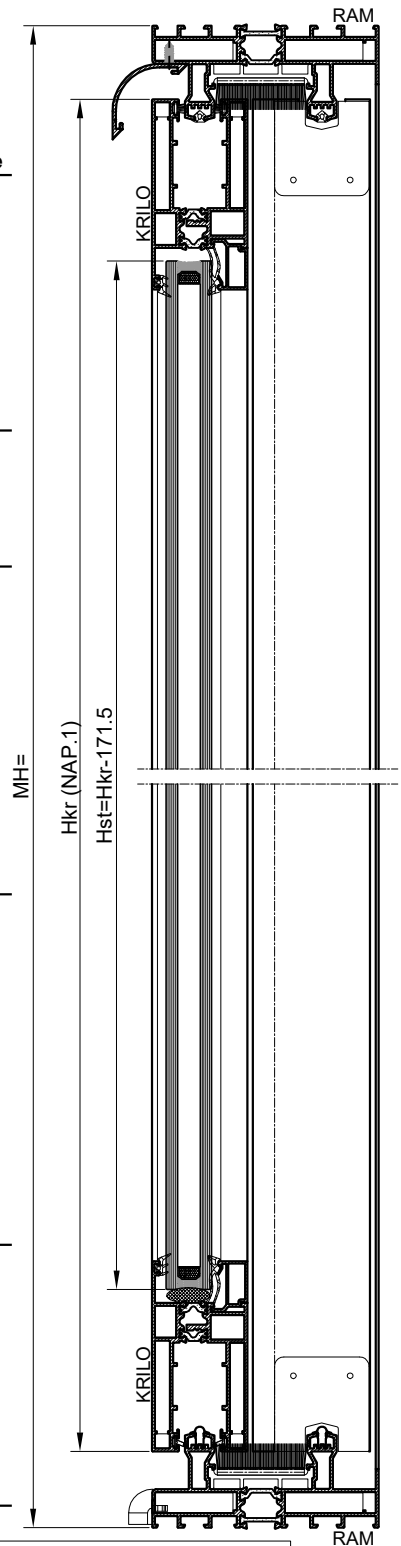

- Okov za klizne i podizno klizne sisteme izabrati iz kataloga str.403.08.01.....

\* koristi se za Termo 120 klizno

\*\* koristi se za Termo 120 podizno klizno

\*\*\* koristi se za Termo 120-D podizno klizno

**NAP.1**

Hkr=MH-83 (Hautau)\*; Hkr=MH-83 (Hautau)\*\*

Hkr=MH-84.5 (Notter)\*; Hkr=MH-82 (Hautau)\*\*\*

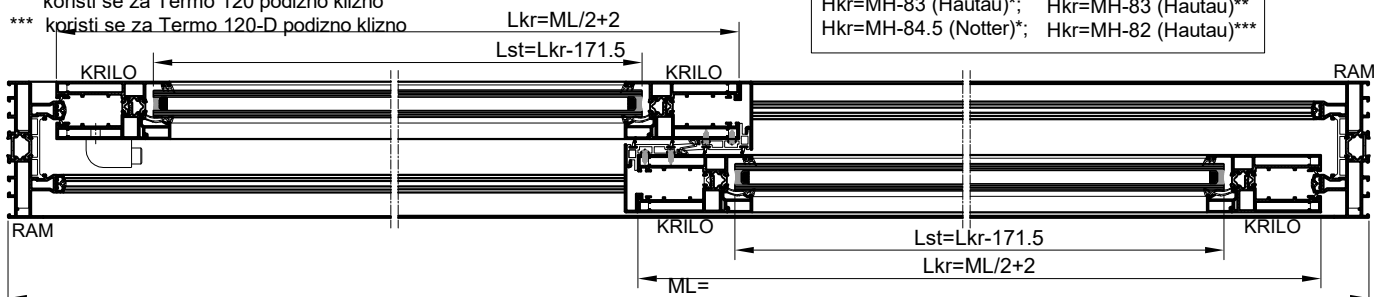

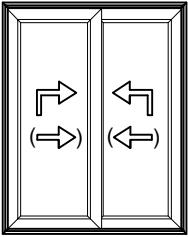

Profili Termo 120	mjera	kom.	pilanje
Ram FT-0701	ML	2	45-45
Ram FT-0701	MH	2	45-45
Krilo FT-0711	ML/2-8	4	45-45
Krilo FT-0711	MH-82	4	45-45
Lajsna F-1529	Hkr	2	90-90
Maska vanjska F-1231	L-44.5	1	90-90
Staklo lajsna Z40-665	Lkr-116	4	90-90
Staklo lajsna Z40-665	Hkr-160	4	90-90
Kutna spojnica 710.520		8	
Kutna spojnica 710.519		8	
Kutna spojnica 710.011		16	
Kutna spojnica 731.010		8	
Kutna spojnica 730.017		16	
Kutna spojnica 730.001		24	
Čep maske krila 375.016		4	
Odbojnik 375.020		2	
Čep profila maske F-1231 375.018		1 par	
Čep za odvod vode 370.070		2	
Umetak sa četkicom 340.006*		2	
Umetak sa četkicom 340.007**		1	
Gumeni umetak 360.013**		1	
Usmjerivač krila 373.061 *(**)		4	
Brтва prema staklu vanjska 321.002 (staklo 24 mm)	Hkr	4	
Brтва prema staklu vanjska 321.002 (staklo 24 mm)	Lkr	4	
Brтва prema staklu unutarnja 311.003 (staklo 24 mm)	Hkr	4	
Brтва prema staklu unutarnja 311.003 (staklo 24 mm)	Lkr	4	
Brтва vertikalnog pojasa krila 344.073	Hkr	2	
Brтва u krilu 347.011**	4Lkr+4Hkr		
Četkica u krilu 347.004*	8Lkr+4Hkr		
Četkica u krilu 347.004**	4Lkr		
Brтва na spoju dva krila 347.012	4Hkr		
Brтва u ramu 344.052	2ML+4MH		
PVC profil 374.026	MH-40.5	2	45-45
PVC profil 374.026	ML-40.5	2	45-45
PVC profil 374.088	Hkr	2	90-90
PVC podmetač kotačića 374.096	L=200 mm	4	90-90
Al vodilica F-1112	ML-104	2	90-90

- Okov za klizne i podizno klizne sisteme izabrati iz kataloga str.403.08.01.....

\* koristi se za Termo 120 klizno

\*\* koristi se za Termo 120 podizno klizno

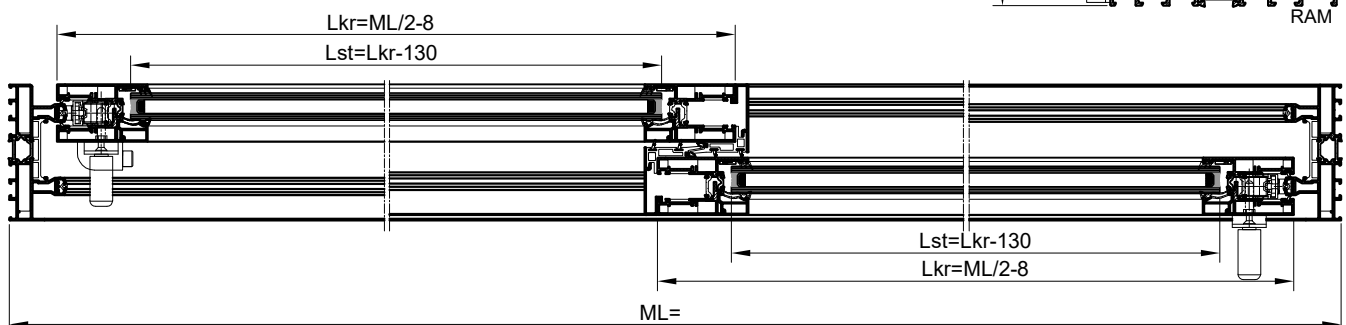
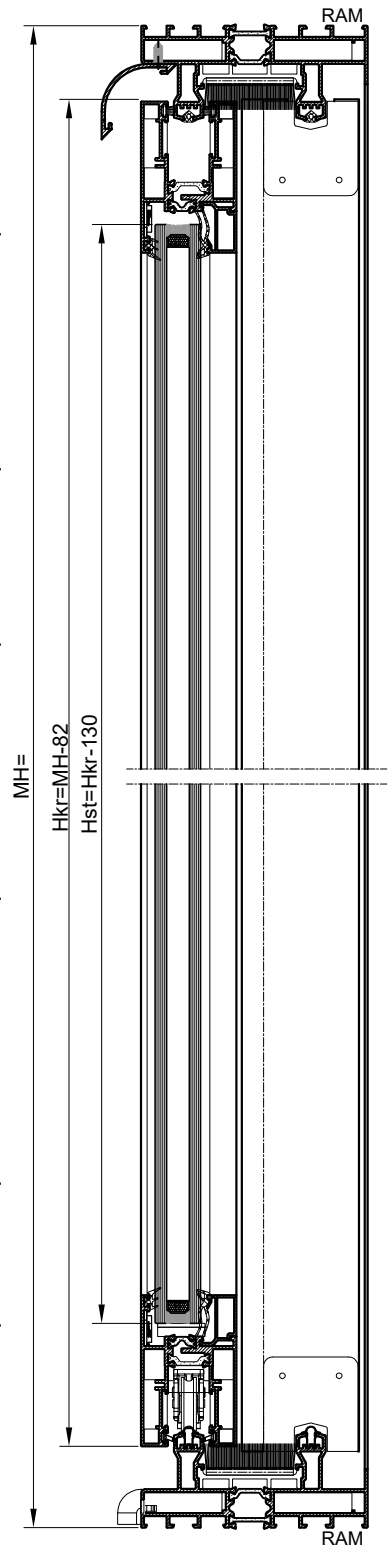

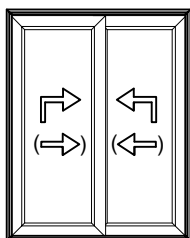

### Profili Termo 120

		mjera	kom.	pilanje
Ram FT-0703	.....	ML	2	45-45
Ram FT-0703	.....	MH	2	45-45
Krilo FT-0710	.....	ML/2+14.5	4	45-45
Krilo FT-0710	.....	MH-84	4	45-45
Lajsna F-1529	.....	Hkr	2	90-90
Umetak gornji F-0852**	.....	ML-76	2	90-90
Umetak gornji TI-916*	.....	ML-76	2	90-90
Umetak donji F-0919	.....	ML-79	2	90-90
Maska vanjska F-1231	.....	ML-44.5	1	90-90
Staklo lajsna Z40-665	.....	Lkr-157.2	4	90-90
Staklo lajsna Z40-665	.....	Hkr-201	4	90-90
Kutna spojnica 710.445	.....		8	
Kutna spojnica 710.504	.....		8	
Kutna spojnica 710.011	.....		16	
Kutna spojnica 730.013	.....		8	
Kutna spojnica 730.001	.....		24	
Čep maske krila 375.016	.....		4	
Odbojnik 375.020	.....		2	
Čep profila maske F-1231 375.018	.....		1 par	
Čep za odvod vode 370.070	.....		2	
Usmjerivač krila 373.061*(**)	.....		4	
Umetak sa četkicom 340.007*	.....		2	
Umetak sa četkicom 340.007**	.....		1	
Gumeni umetak 360.012**	.....		1	
Brtva prema staklu vanjska 321.002 (staklo 24 mm)	.....	Hkr	4	
Brtva prema staklu vanjska 321.002 (staklo 24 mm)	.....	Lkr	4	
Brtva prema staklu unutarnja 311.003 (staklo 24 mm)	.....	Hkr	4	
Brtva prema staklu unutarnja 311.003 (staklo 24 mm)	.....	Lkr	4	
Brtva vertikalnog pojasa krila 344.073	.....	Hkr	2	
Brtva u krilu 347.011**	.....	4Lkr+4Hkr		
Četkica u krilu 347.004*	.....	8Lkr+4Hkr		
Četkica u krilu 347.004**	.....	4Lkr		
Brtva na spoju dva krila 347.012	.....	4Hkr		
Brtva u ramu 344.052	.....	4MH		
PVC profil 374.026	.....	MH-43.5	2	45-45
PVC profil 374.026	.....	ML-43.5	2	45-45
PVC profil 374.075	.....	Hkr	2	90-90
PVC podmetač kotačića 374.042	.....	L=200 mm	4	90-90
Al vodilica F-1112	.....	ML-79	2	90-90
PVC podmetač brave 374.028* i **	.....	Hkr	2	90-90

- Okov za klizne i podizno klizne sisteme izabrati iz kataloga str.403.08.01.....

\* koristi se za Termo 120 klizno

\*\* koristi se za Termo 120 podizno klizno

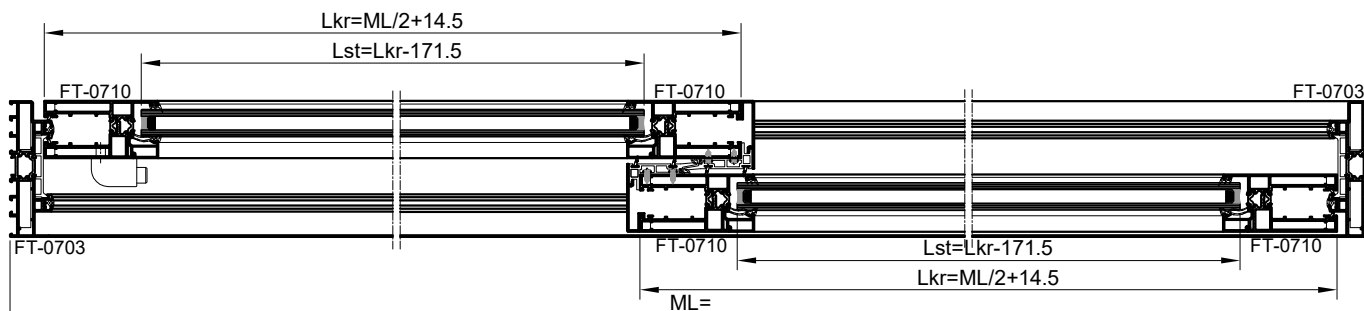
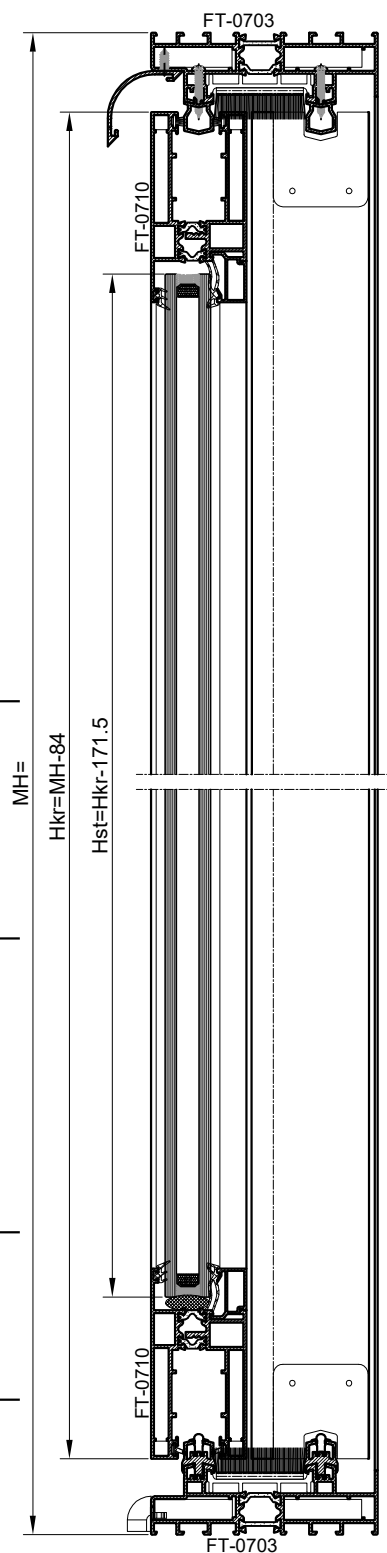

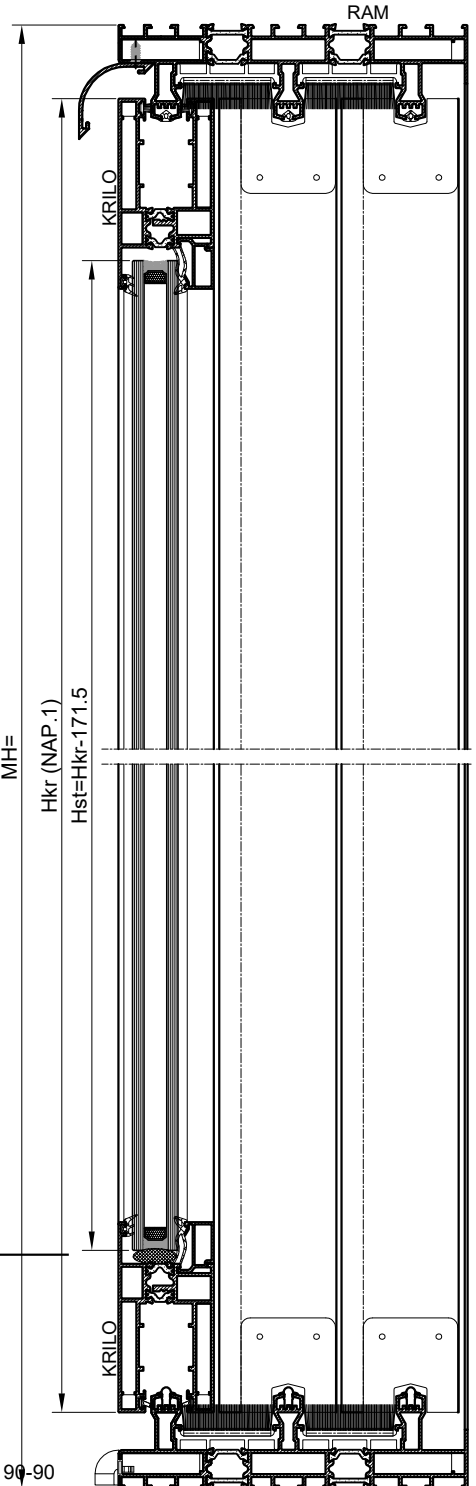
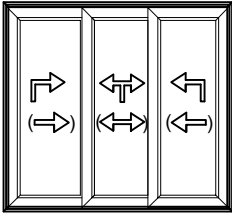

Profili Termo 120	Profili Termo 120-D	mjera	kom.	planje
Ram FT-0702	Ram FT-0721F	ML	2	45-45
Ram FT-0702	Ram FT-0721F	MH	2	45-45
Krilo FT-0710	Krilo FT-0725F	ML/3+32	6	45-45
Krilo FT-0710	Krilo FT-0725F	Hkr (NAP.1)	6	45-45
Lajsna F-1529	Lajsna F-1528	Hkr	4	90-90
Maska vanjska F-1231	Maska vanjska F-1231	ML-44.5	1	90-90
Staklo lajsna Z40-665	Staklo lajsna Z40-660	Lkr-157.2	6	90-90
Staklo lajsna Z40-665	Staklo lajsna Z40-660	Hkr-201	6	90-90
	Držač točkića F-1676	Lkr-50	6	90-90
Kutna spojnica 710.445			12	
Kutna spojnica 710.504			12	
Kutna spojnica 710.011			24	
Kutna spojnica 730.013			8	
Kutna spojnica 730.001			36	
Čep maske krila 375.016			8	
Odbojnik 375.020			4	
Čep profila maske F-1231 375.018			1 par	
Čep za odvod vode 370.070			2	
Usmjerivač krila 373.061 (**)			6	
Usmjerivač krila 373.060***			6	
Umetak sa četkicom 340.007*			4	
Umetak sa četkicom 340.007**			2	
Umetak sa četkicom 340.046***			2	
Gumeni umetak 360.012**			2	
Gumeni umetak 360.014***			2	
Izolacijski umetak 340.044***			3Hkr	
Brtva prema staklu vanjska 321.002 (staklo 24 mm* i **)		Hkr	6	
Brtva prema staklu vanjska 321.002 (staklo 24 mm* i **)		Lkr	6	
Brtva prema staklu unutarnja 311.003 (staklo 24 mm* i **)		Hkr	6	
Brtva prema staklu unutarnja 311.003 (staklo 24 mm* i **)		Lkr	6	
Brtva prema staklu 311.001 (staklo 44 mm***)		Hkr	12	
Brtva prema staklu 311.001 (staklo 44 mm***)		Lkr	12	
Brtva vertikalnog pojasa krila 344.073		Hkr	4	
Brtva u krilu 347.011**		6Lkr+4Hkr		
Brtva u krilu 347.012***		12Lkr+4Hkr		
Četkica u krilu 347.004*		12Lkr+4Hkr		
Četkica u krilu 347.004**		6Lkr		
Brtva na spoju dva krila 347.012		8Hkr		
Brtva u ramu 344.052		3ML+6MH		
PVC profil 374.026* i **		MH-40.5	4	
PVC profil 374.026* i **		ML-40.5	4	
PVC profil 374.051***		MH-40.5	4	
PVC profil 374.051***		ML-40.5	4	
PVC profil 374.075		Hkr	4	
PVC podmetač kotačića 374.042* i **		L=200 mm	6	
PVC podmetač kotačića 374.052***		L=200 mm	6	
Al vodilica F-1112		ML-104	3	
PVC podmetač brave 374.028* i **		Hkr	3	
PVC podmetač brave 374.060***		Hkr	3	

\* koristi se za Termo 120 klizno

\*\* koristi se za Termo 120 podizno klizno

\*\*\* koristi se za Termo 120-D podizno klizno

Lk=ML/3+32

Lst=Lkr-171.5

KRILLO

RAM

ML

Lst=Lkr-171.5

Lkr=ML/3+32

KRILLO

RAM

ML

Lst=Lkr-171.5

Lkr=ML/3+32

KRILLO

RAM

ML

Lst=Lkr-171.5

Lkr=ML/3+32

KRILLO

RAM

ML

**NAP.1**  
 Hkr=MH-83 (Hautau)\*; Hkr=MH-83 (Hautau)\*\*  
 Hkr=MH-84.5 (Notter)\*; Hkr=MH-82 (Hautau)\*\*\*

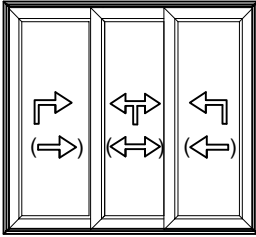

### Profili Termo 120

	mjera	kom.	pilanje
Ram FT-0702	ML	2	45-45
Ram FT-0702	MH	2	45-45
Krilo FT-0711	ML/3+18	6	45-45
Krilo FT-0711	MH-82	6	45-45
Lajsna F-1529	Hkr	4	90-90
Maska vanjska F-1231	ML-44.5	1	90-90
Staklo lajsna Z40-665	Lkr-116	6	90-90
Staklo lajsna Z40-665	Hkr-160	6	90-90
Kutna spojnica 710.520		12	
Kutna spojnica 710.519		12	
Kutna spojnica 710.011		24	
Kutna spojnica 731.010		12	
Kutna spojnica 730.017		24	
Kutna spojnica 730.001		36	
Čep maske krila 375.016		8	
Odbojnik 375.020		4	
Čep profila maske F-1231 375.018		1 par	
Čep za odvod vode 370.070		2	
Umetak sa četkicom 340.007*		2	
Umetak sa četkicom 340.006*		2	
Umetak sa četkicom 340.007**		2	
Gumeni umetak 360.013**		2	
Usmjerivač krila 373.061(**)		6	
Brtva prema staklu vanjska 321.002 (staklo 24 mm)	Hkr	6	
Brtva prema staklu vanjska 321.002 (staklo 24 mm)	Lkr	6	
Brtva prema staklu unutarnja 311.003 (staklo 24 mm)	Hkr	6	
Brtva prema staklu unutarnja 311.003 (staklo 24 mm)	Lkr	6	
Brtva vertikalnog pojasa krila 344.073	Hkr	4	
Brtva u krilu 347.011**	6Lkr+4Hkr		
Četkica u krilu 347.004*	12Lkr+4Hkr		
Četkica u krilu 347.004**	6Lkr		
Brtva na spoju dva krila 347.012	8Hkr		
Brtva u ramu 344.052	3ML+6MH		
PVC profil 374.026	MH-40.5	4	45-45
PVC profil 374.026	ML-40.5	4	45-45
PVC profil 374.088	Hkr	4	90-90
PVC podmetač kotačica 374.096	L=200 mm	6	90-90
Al vodilica F-1112	ML-104	3	90-90

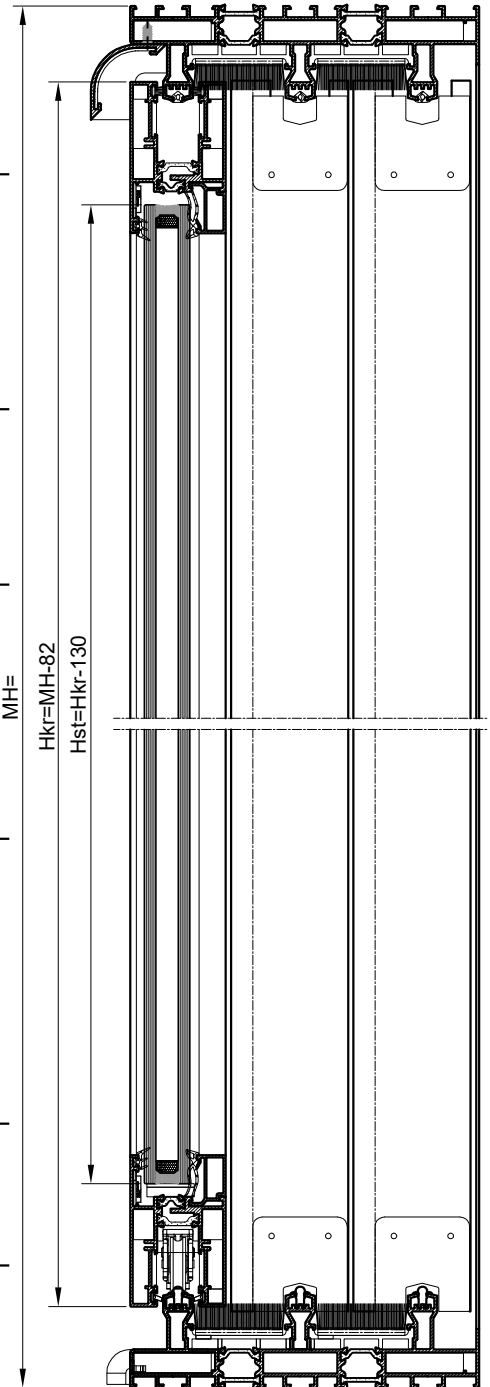

- Okov za klizne i podizno klizne sisteme izabrati iz kataloga str.403.08.01.....

\* koristi se za Termo 120 klizno

\*\* koristi se za Termo 120 podizno klizno

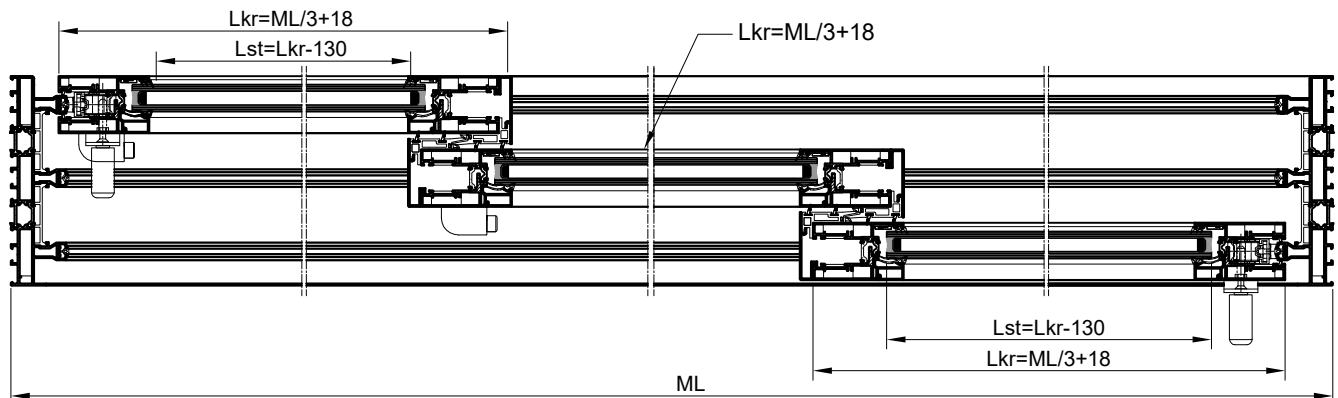

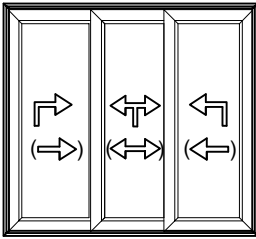

### Profili Termo 120

	mjera	kom.	pilanje
Ram FT-0704	ML	2	45-45
Ram FT-0704	MH	2	45-45
Kriilo FT-0710	ML/3+39.5	6	45-45
Kriilo FT-0710	MH-84	6	45-45
Lajsna F-1529	Hkr	4	90-90
Umetak gornji F-0852**	ML-76	3	90-90
Umetak gornji TI-916*	ML-76	3	90-90
Umetak donji F-0919	ML-79	3	90-90
Maska vanjska F-1231	ML-44.5	1	90-90
Staklo lajsna Z40-665	Lkr-157.2	6	90-90
Staklo lajsna Z40-665	Hkr-201	6	90-90
<hr/>			
Kutna spojnica 710.445		12	
Kutna spojnica 710.504		12	
Kutna spojnica 710.011		24	
Kutna spojnica 730.013		8	
Kutna spojnica 730.001		36	
<hr/>			
Čep maske kriila 375.016		8	
Odbojnik 375.020		4	
Čep profila maske F-1231 375.018		1 par	
Čep za odvod vode 370.070		2	
Usmjerivač kriila 373.061 *(**)		6	
Umetak sa četkicom 340.007*		4	
Umetak sa četkicom 340.007**		2	
Gumeni umetak 360.012**		2	
<hr/>			
Brtva prema staklu vanjska 321.002 (staklo 24 mm)	Hkr	6	
Brtva prema staklu vanjska 321.002 (staklo 24 mm)	Lkr	6	
Brtva prema staklu unutarnja 311.003 (staklo 24 mm)	Hkr	6	
Brtva prema staklu unutarnja 311.003 (staklo 24 mm)	Lkr	6	
Brtva vertikalnog pojasa kriila 344.073	Hkr	4	
Brtva u kriilu 347.011**	6Lkr+4Hkr		
Četkica u kriilu 347.004*	12Lkr+4Hkr		
Četkica u kriilu 347.004**	6Lkr		
Brtva na spoju dva kriila 347.012	8Hkr		
Brtva u ramu 344.052	6MH		
<hr/>			
PVC profil 374.026	MH-43.5	4	45-45
PVC profil 374.026	ML-43.5	4	45-45
PVC profil 374.075	Hkr	4	90-90
PVC podmetač kotačića 374.042	L=200 mm	6	90-90
Al vodilica F-1112	ML-79	3	90-90
PVC podmetač brave 374.028* i **	Hkr	3	90-90

- Okov za klizne i podizno klizne sisteme izabrati iz kataloga str.403.08.01.....

\* koristi se za Termo 120 klizno

\*\* koristi se za Termo 120 podizno klizno

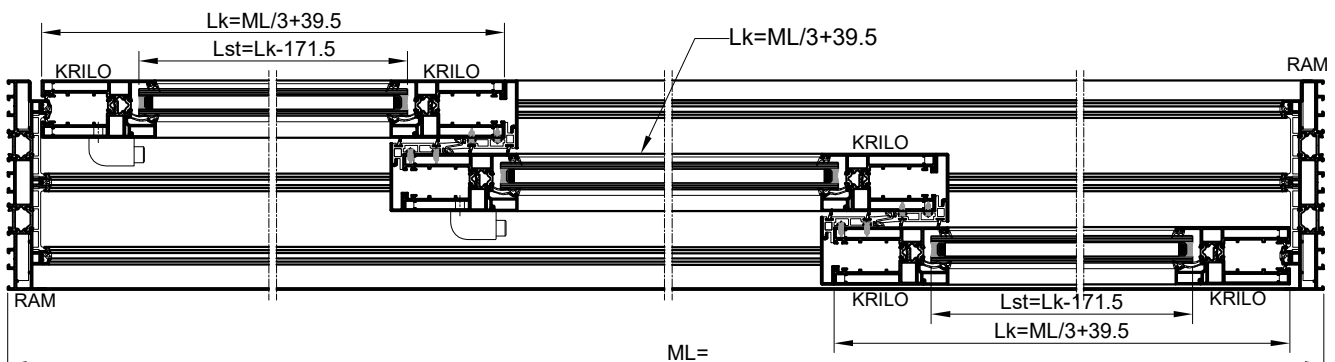
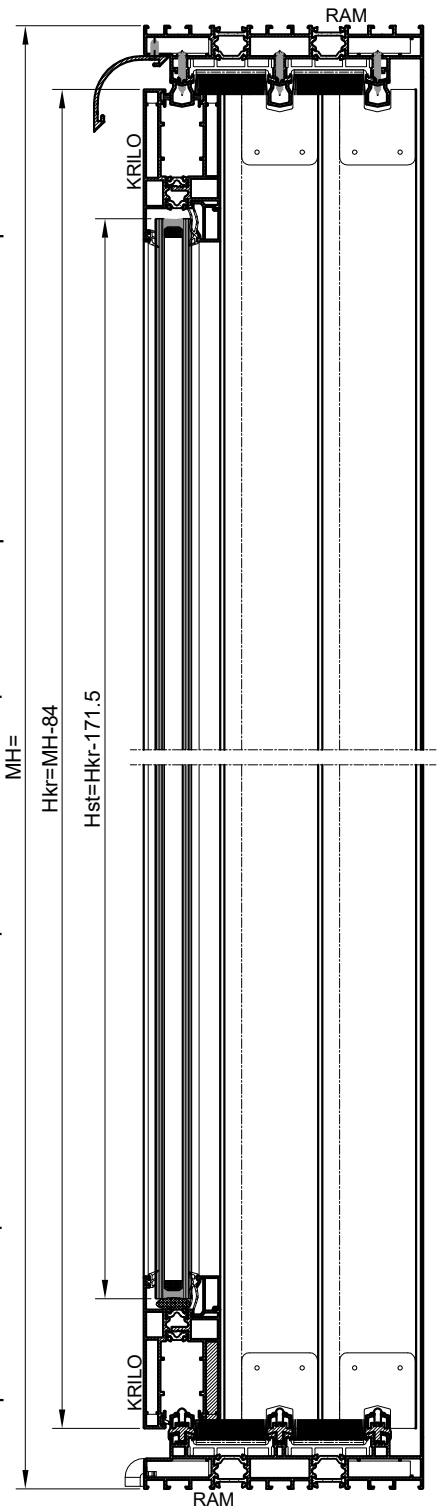

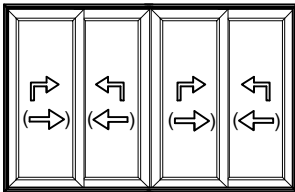

Profili Termo 120		Profili Termo 120-D		mjera	kom.	pilanje
Ram FT-0701	.....	Ram FT-0720F	.....	ML	2	45-45
Ram FT-0701	.....	Ram FT-0720F	.....	MH	2	45-45
Krilo FT-0710	.....	Krilo FT-0725F	.....	ML/4+23	8	45-45
Krilo FT-0710	.....	Krilo FT-0725F	.....	Hkr (NAP.1)	8	45-45
Spojnica FT-0717	.....	Spojnica FT-0733F	.....	Hkr	1	90-90
Lajsna F-1529	.....	Lajsna F-1528	.....	Hkr	4	90-90
Maska vanjska F-1231	.....	Maska vanjska F-1231	.....	ML-44.5	1	90-90
Staklo lajsna Z40-665	.....	Staklo lajsna Z40-660	.....	Lkr-157.2	8	90-90
Staklo lajsna Z40-665	.....	Staklo lajsna Z40-660	.....	Hkr-201	8	90-90
		Držač točkica F-1676	.....	Lkr-50	8	90-90
Kutna spojnica 710.445				.....	16	
Kutna spojnica 710.504				.....	16	
Kutna spojnica 710.011				.....	32	
Kutna spojnica 730.013				.....	8	
Kutna spojnica 730.001				.....	48	
Čep maske krila 375.016				.....	8	
Odbojnik 375.020				.....	4	
Čep profila maske F-1231 375.018				.....	1 par	
Čep za odvod vode 370.070				.....	2	
Usmjerivač krila 373.061 *(**)				.....	8	
Usmjerivač krila 373.060***				.....	8	
Umetak sa četkicom 340.007*				.....	4	
Umetak sa četkicom 340.007**				.....	2	
Umetak sa četkicom 340.046***				.....	2	
Gumeni umetak 360.012**				.....	2	
Gumeni umetak 360.014***				.....	2	
Izolacijski umetak 340.044***				.....	4Hkr	
Brtva prema staklu vanjska 321.002 (staklo 24 mm* i **)				.....	Hkr	8
Brtva prema staklu vanjska 321.002 (staklo 24 mm* i **)				.....	Lkr	8
Brtva prema staklu unutarnja 311.003 (staklo 24 mm* i **)				.....	Hkr	8
Brtva prema staklu unutarnja 311.003 (staklo 24 mm* i **)				.....	Lkr	8
Brtva prema staklu 311.001 (staklo 44 mm***)				.....	Hkr	16
Brtva prema staklu 311.001 (staklo 44 mm***)				.....	Lkr	16
Brtva vertikalnog pojasa krila 344.073				.....	Hkr	4
Brtva u krilu 347.011**				.....	8Lkr+8Hkr	
Brtva u krilu 347.012***				.....	16Lkr+8Hkr	
Četkica u krilu 347.004*				.....	16Lkr+8Hkr	
Četkica u krilu 347.004**				.....	8Lkr	
Brtva na spoju dva krila 347.012				.....	8Hkr	
Brtva u ramu 344.052				.....	2ML+4MH	
PVC profil 374.026* i **				.....	MH-40.5	2 45-45
PVC profil 374.026* i **				.....	ML-40.5	2 45-45
PVC profil 374.051***				.....	MH-40.5	2 45-45
PVC profil 374.051***				.....	ML-40.5	2 45-45
PVC profil 374.075				.....	Hkr	4 90-90
PVC podmetač kotačića 374.042* i **				.....	L=200 mm	8 90-90
PVC podmetač kotačića 374.052***				.....	L=200 mm	8 90-90
Al vodilica F-1112				.....	ML-104	2 90-90
PVC podmetač brave 374.028* i **				.....	Hkr	4 90-90
PVC podmetač brave 374.060***				.....	Hkr	4 90-90

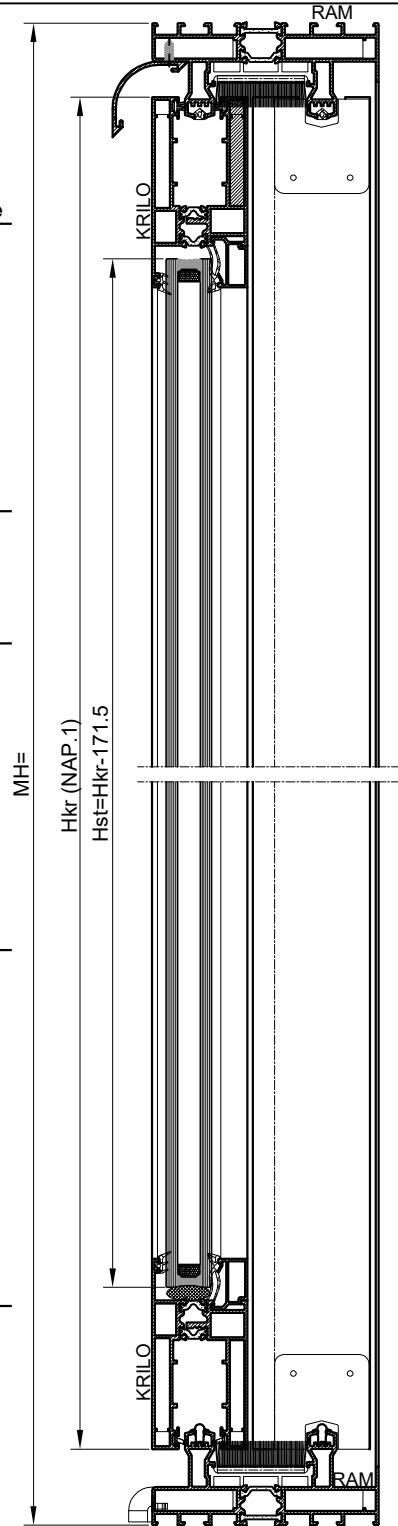

**NAP.1**  
 Hkr=MH-83 (Hautau)\*; Hkr=MH-83 (Hautau)\*\*  
 Hkr=MH-84.5 (Notter)\*; Hkr=MH-82 (Hautau)\*\*\*

**- Okov za klizne i podizno klizne sisteme  
 izabrati iz kataloga str.403.08.01.....**

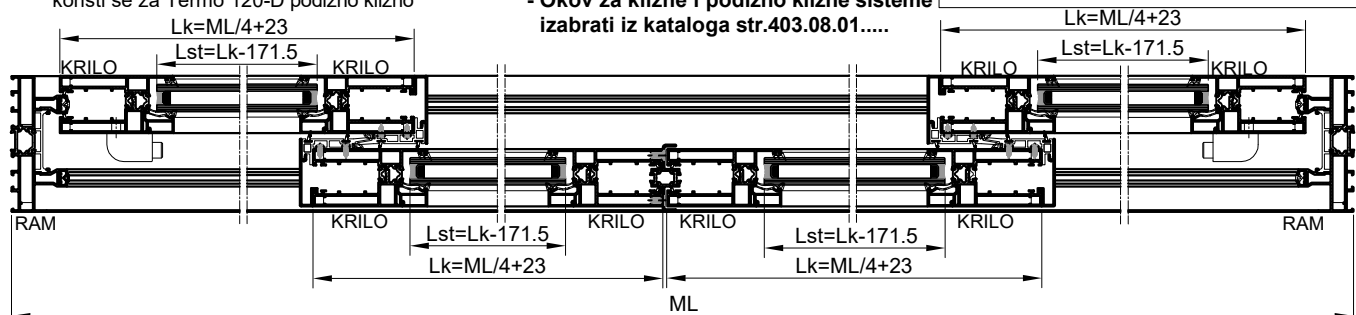

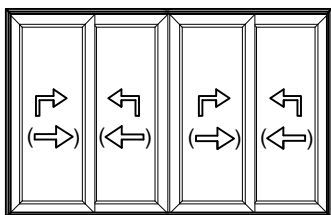

### Profili Termo 120

	mjera	kom.	pilanje
Ram FT-0701	ML	2	45-45
Ram FT-0701	MH	2	45-45
Krilo FT-0711	ML/4+12.5	8	45-45
Krilo FT-0711	MH-82	8	45-45
Spojnica FT-0717	MH-82	1	90-90
Lajsna F-1529	Hkr	4	90-90
Maska vanjska F-1231	ML-44.5	1	90-90
Staklo lajsna Z40-665	Lkr-116	8	90-90
Staklo lajsna Z40-665	Hkr-160	8	90-90
Kutna spojnica 710.520		16	
Kutna spojnica 710.519		16	
Kutna spojnica 710.011		32	
Kutna spojnica 731.010		16	
Kutna spojnica 730.017		32	
Kutna spojnica 730.001		48	
Čep maske krila 375.016		8	
Odbojnik 375.020		4	
Čep profila maske F-1231 375.018		1 par	
Čep za odvod vode 370.070		2	
Umetak sa četkicom 340.006*		4	
Umetak sa četkicom 340.007**		2	
Gumeni umetak 360.013**		2	
Usmjerivač krila 373.061 *(**)		8	
Brтва prema staklu vanjska 321.002 (staklo 24 mm)	Hkr	8	
Brтва prema staklu vanjska 321.002 (staklo 24 mm)	Lkr	8	
Brтва prema staklu unutarnja 311.003 (staklo 24 mm)	Hkr	8	
Brтва prema staklu unutarnja 311.003 (staklo 24 mm)	Lkr	8	
Brтва vertikalnog pojasa krila 344.073	Hkr	4	
Brтва u krilu 347.011**	8Lkr+8Hkr		
Četkica u krilu 347.004*	16Lkr+8Hkr		
Četkica u krilu 347.004**	8Lkr		
Brтва na spoju dva krila 347.012	8Hkr		
Brтва u ramu 344.052	2ML+4MH		
PVC profil 374.026	MH-40.5	2	45-45
PVC profil 374.026	ML-40.5	2	45-45
PVC profil 374.088	Hkr	4	90-90
PVC podmetač kotačića 374.096	L=200 mm	8	90-90
Al vodilica F-1112	ML-104	2	90-90

- Okov za klizne i podizno klizne sisteme izabrati iz kataloga str.403.08.01.....

\* koristi se za Termo 120 klizno

\*\* koristi se za Termo 120 podizno klizno

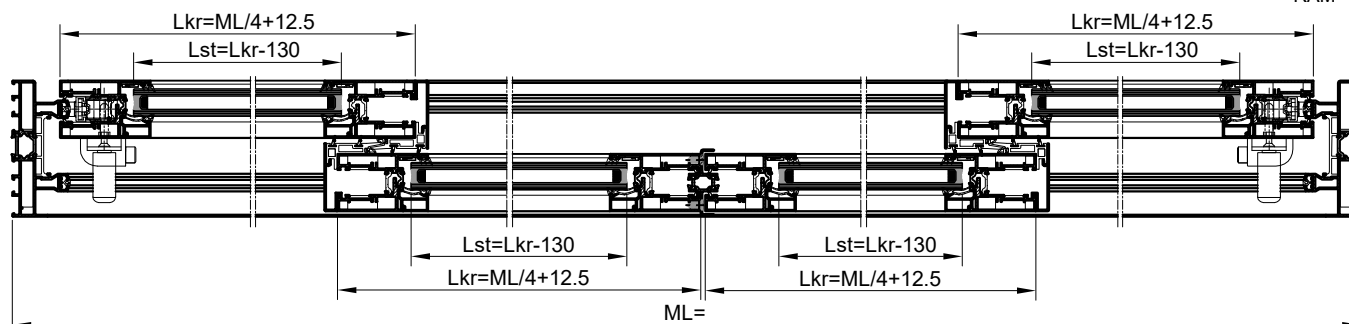
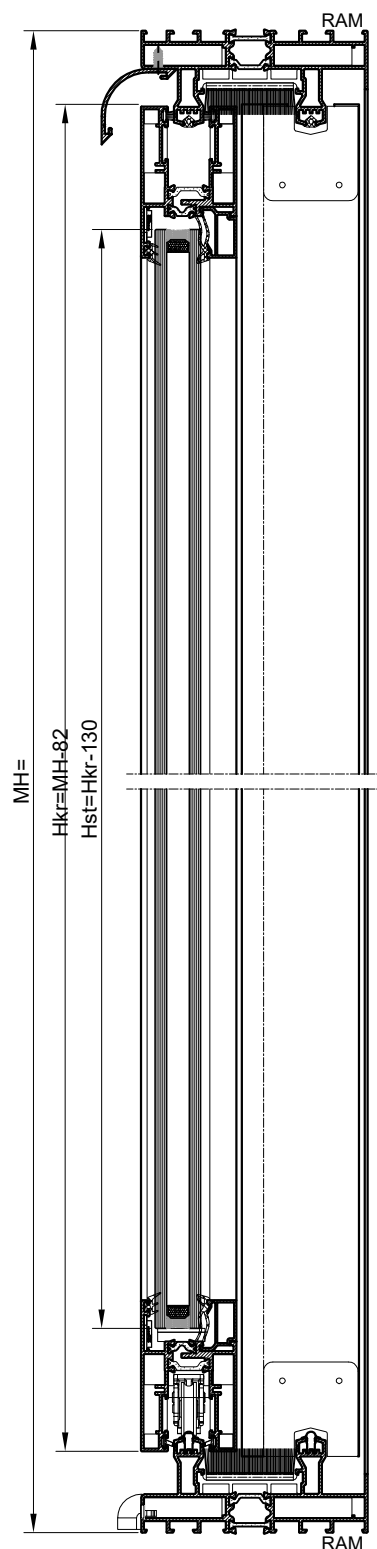

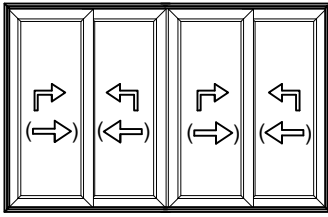

### Profili Termo 120

	mjera	kom.	pilanje
Ram FT-0703	ML	2	45-45
Ram FT-0703	MH	2	45-45
Krilo FT-0710	ML/2+14.5	4	45-45
Krilo FT-0710	MH-84	4	45-45
Lajsna F-1529	Hkr	2	90-90
Umetak gornji F-0852**	ML-76	2	90-90
Umetak gornji TI-916*	ML-76	2	90-90
Umetak donji F-0919	ML-79	2	90-90
Maska vanjska F-1231	ML-44.5	1	90-90
Staklo lajsna Z40-665	Lkr-157.2	4	90-90
Staklo lajsna Z40-665	Hkr-201	4	90-90
<hr/>			
Kutna spojnica 710.445		8	
Kutna spojnica 710.504		8	
Kutna spojnica 710.011		16	
Kutna spojnica 730.013		8	
Kutna spojnica 730.001		24	
<hr/>			
Čep maske krila 375.016		4	
Odbojnik 375.020		2	
Čep profila maske F-1231 375.018		1 par	
Čep za odvod vode 370.070		2	
Usmjerivač krila 373.061 *(**)		4	
Umetak sa četkicom 340.007*		4	
Umetak sa četkicom 340.007**		2	
Gumeni umetak 360.012**		2	
<hr/>			
Brtva prema staklu vanjska 321.002 (staklo 24 mm)	Hkr	4	
Brtva prema staklu vanjska 321.002 (staklo 24 mm)	Lkr	4	
Brtva prema staklu unutarnja 311.003 (staklo 24 mm)	Hkr	4	
Brtva prema staklu unutarnja 311.003 (staklo 24 mm)	Lkr	4	
Brtva vertikalnog pojasa krila 344.073	Hkr	2	
Brtva u krilu 347.011**	8Lkr+8Hkr		
Četkica u krilu 347.004*	16Lkr+8Hkr		
Četkica u krilu 347.004**	8Lkr		
Brtva na spoju dva krila 347.012	8Hkr		
Brtva u ramu 344.052	4MH		
<hr/>			
PVC profil 374.026	MH-43.5	2	45-45
PVC profil 374.026	ML-43.5	2	45-45
PVC profil 374.075	Hkr	4	90-90
PVC podmetač kotačića 374.042	L=200 mm	8	90-90
Al vodilica F-1112	ML-79	2	90-90
PVC podmetač brave 374.028* i **	Hkr	4	90-90

- Okov za klizne i podizno klizne sisteme izabrati iz kataloga str.403.08.01.....

\* koristi se za Termo 120 klizno

\*\* koristi se za Termo 120 podizno klizno

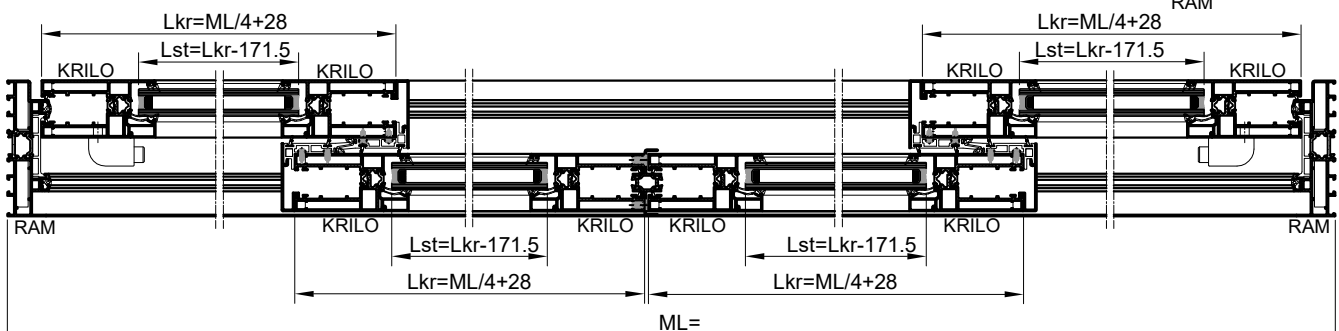
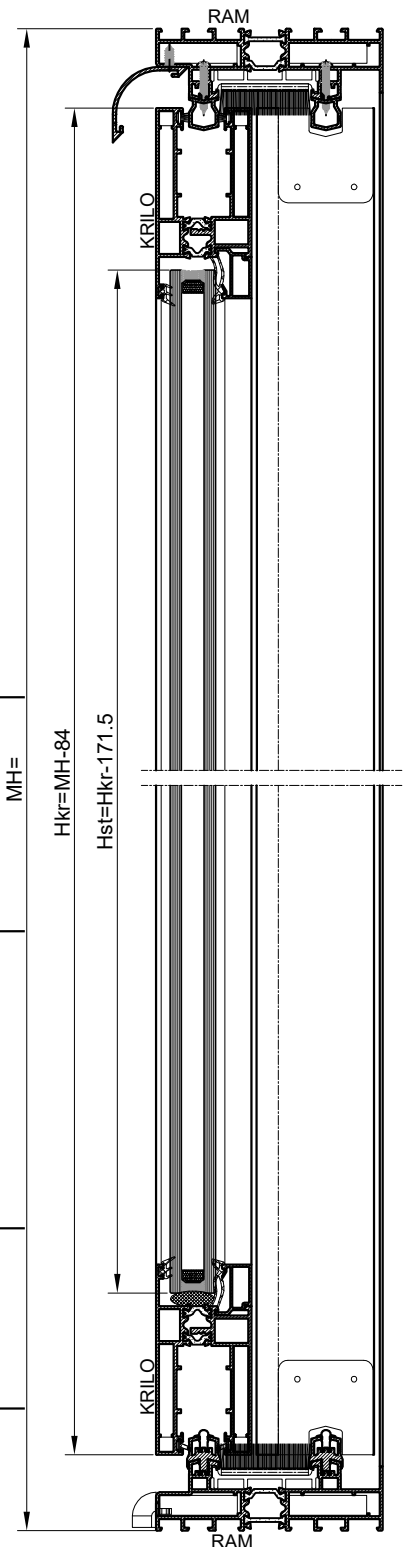

Profili Termo 120	Profili Termo 120-D	mjera	kom.	pilanje
Ram FT-0705	Ram FT-0722F	ML	2	45-45
Ram FT-0705	Ram FT-0722F	MH	2	45-45
Krilo FT-0710	Krilo FT-0725F	ML/2+23	2	45-45
Krilo FT-0710	Krilo FT-0725F	MH-79.5	2	45-45
Prečka FT-0715	Krilo FT-0730F	MH-46.5	1	90-90
Lajsna F-1529	Lajsna F-1528	Hkr	1	90-90
Lajsna F-1529	Lajsna F-1528	MH-56	1	90-90
Maska vanjska F-1231	Maska vanjska F-1231	ML-48	1	90-90
Lajsna F-0847	Lajsna F-1444	Lkr-89	2	90-90
Lajsna F-0846	Lajsna F-1445	MH-106	1	90-90
Staklo lajsna Z40-665	Staklo lajsna Z40-660	Lkr-157.2	2	90-90
Staklo lajsna Z40-665	Staklo lajsna Z40-660	Hkr-201	2	90-90
Staklo lajsna Z40-665	Staklo lajsna Z40-660	Lfix-106.6	2	90-90
Staklo lajsna Z40-665	Staklo lajsna Z40-660	MH-100	2	90-90
	Držač točkica F-1676	Lkr-50	2	90-90

Kutna spojnica 710.445			4	
Kutna spojnica 710.504			4	
Kutna spojnica 710.011			8	
Kutna spojnica 730.008			4	
Kutna spojnica 730.001			16	
Kutna spojnica 710.446* i **			4	
Kutna spojnica 710.478***			4	
Čep maske krila 375.016			2	
Odbojnik 375.020			2	
Čep profila maske F-1231 375.018			1 par	
Čep za odvod vode 370.070			2	
Usmjerivač krila 373.061 (**)			2	
Usmjerivač krila 373.060***			2	
Umetak sa četkicom 340.005*			1	
Umetak sa četkicom 340.402*			1	
Umetak sa četkicom 340.402**			1	
Umetak 363.019**			1	
Umetak sa četkicom 340.041***			1	
Gumeni umetak 360.015***			1	
Izolacijski umetak 340.042***			2Lkr	
Izolacijski umetak 340.044***			Hkr	
Izolacijski umetak 340.045***			Hkr	
Izolacijski umetak 340.013***			2Lkr+2Hkr+2Lfix+2MH	
Brtva prema staklu vanjska 321.002 (staklo 24 mm* i **)			2Lkr+2Hkr	
Brtva prema staklu vanjska 321.002 (staklo 24 mm* i **)			2Lfix+2MH	
Brtva prema staklu unutarnja 311.003 (staklo 24 mm* i **)			2Lkr+2Hkr	
Brtva prema staklu unutarnja 311.003 (staklo 24 mm* i **)			2Lfix+2MH	
Brtva prema staklu 311.001 (staklo 44 mm***)			4Lkr+4Hkr	
Brtva prema staklu 311.001 (staklo 44 mm***)			4Lfix+4MH	
Brtva vertikalnog pojasa krila 344.073			2Hkr	
Brtva u krilu 347.011**			2Lkr+2Hkr	
Brtva u krilu 347.012***			4Lkr+2Hkr	
Četkica u krilu 347.004*			4Lkr+2Hkr	
Četkica u krilu 347.004**			2Lkr	
Brtva na spoju dva krila 347.012			4Hkr	
Brtva u ramu 344.052			ML+2MH	
Brtva u ramu 344.015			2Lkr+MH	
Vodilica F-1112			ML-103	1
Pvc umetak 374.075			Hkr	1 90-90
Pvc umetak 374.075			MH-46.5	1 90-90
Pvc umetak 374.042* i **			L=200 mm	2 90-90
Pvc umetak 374.052***			L=200 mm	2 90-90
PVC podmetač brave 374.028* i **			Hkr	1 90-90
PVC podmetač brave 374.060***			Hkr	1 90-90

- Okov za klizne i podizno klizne sisteme izabrati iz kataloga str.403.08.01.....

$$Lkr=(ML/2)+23 ; /Lkr \leq Lfix/$$

$$Lst=Lkr-177^{***}$$

$$Lst=Lkr-171.5^{* i **}$$

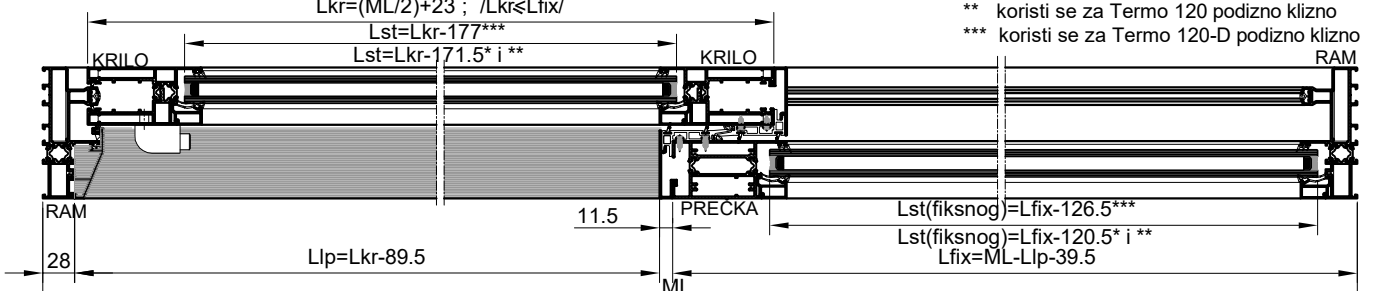

\* koristi se za Termo 120 klizno

\*\* koristi se za Termo 120 podizno klizno

\*\*\* koristi se za Termo 120-D podizno klizno

Hst(fiksno)=MH-70\* i \*\*

Hst(fixnog)=MH-76\*\*\*

Lst(fiksno)=Lfix-126.5\*\*\*

Lst(fiksno)=Lfix-120.5\* i \*\*

Lfix=ML-Llp-39.5

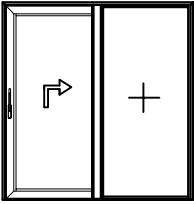

### Profili

Ram T1 931/692	ML	1	45-45
Ram T1 931/692	MH	2	45-90
Krilo FT-0725F	$Lkr=(ML/2)+23$	2	45-45
Krilo FT-0725F	MH-56	2	45-45
Lajsna F-1528	MH-56	1	90-90
Lajsna F-1528	MH-40.5	1	90-90
Prag F-1377	ML-62	1	90-90
Umetak praga F-1378	ML-62	1	90-90
Maska praga F-1381	Lpr-64.2	1	90-90
Vodilica F-1379	ML-87.5	1	90-90
Gornja maska F-1380	Lpr-39.4	1	90-90
Bočna lajsna F-1380	MH-65	1	90-90
Maska vanjska F-1231	ML-48	1	90-90
Prečka fiksnog dijela FT-0730F	MH-35.3	1	90-90
Staklo lajsna Z40-660	Lkr-157.2 ; Lfix-150.6	2 + 3	90-90
Staklo lajsna Z40-660	Hkr-201; MH-40.5 2 + 2		90-90
Držač točkica	Lkr-50	2	90-90
<hr/>			
Kutna spojnica 710.445		4	
Kutna spojnica 710.504		4	
Kutna spojnica 710.011		8	
Kutna spojnica 710.478		2	
Kutna spojnica 730.008		2	
Kutna spojnica 730.001		5	
<hr/>			
Umetak sa četkicom 340.041		1	
Gumeni umetak 361.029		1	
Čep maske krila 375.016		1	
Čep maske krila-donji 375.067		1	
Odbojnik 375.020		2	
Čep za profil maske F-1231 375.018		1 par	
Usmjernivač krila 373.060		2	
Čep praga 375.065		1 par	
<hr/>			
Umetak za kotačiće 374.068	Lkr	1	
Profil na spoju krila i fiksnog 374.075	Hkr	1	
Profil na spoju krila i fiksnog 374.075	MH-40.5	1	
<hr/>			
Brtve za ostakljivanje 311.001	4Lkr+4Hkr+4Lfix+4MH		
Brtva krila prema pragu 344.054	2 Lkr		
Brtva u pragu za masku 344.055	ML/2		
Brtva u utoru rama 344.052	ML+2H		
Brtva za masku F-1380 344.015	ML+MH		
Brtva u vertikalnom pojasu krila 347.012	2Lkr+2Hkr		
Brtva na spoju krila i fiksnog 344.073	2MH		
Brtva na spoju krila i fiksnog 347.012	4MH		
Četkica 347.004	ML+3MH		
PVC podmetač brave 374.060***	Hkr	1	90-90
<hr/>			
Izolacijski umetak ispod stakla 340.013	2(Lkr-156)-2(Hkr-180)		
Izolacijski umetak ispod stakla 340.013	2(Lfix-106)-2(MH-64)		
Izolacijski umetak 340.042	ML/2		
Izolacijski umetak 340.044	Hkr-115		
Izolacijski umetak 340.045	MH-40.5		

$$Lstkrila \times Hstkrila = (Lkr-177) \times (Hkr-177)$$

$$Lstfixnog \times Hstfixnog = (Lfix-126.5) \times (H-60)$$

- Okov za klizne i podizno klizne sisteme izabrati iz kataloga str.403.08.01.....

$$Lkr=(ML/2)+23 ; Lkr < Lfix$$

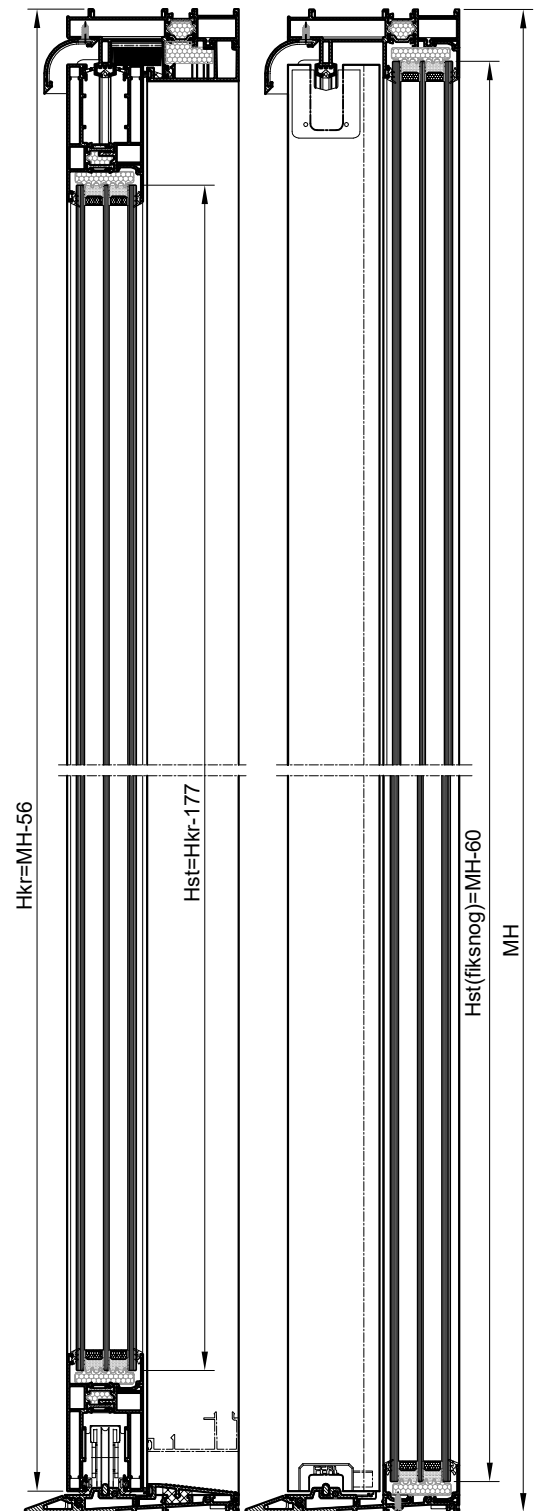
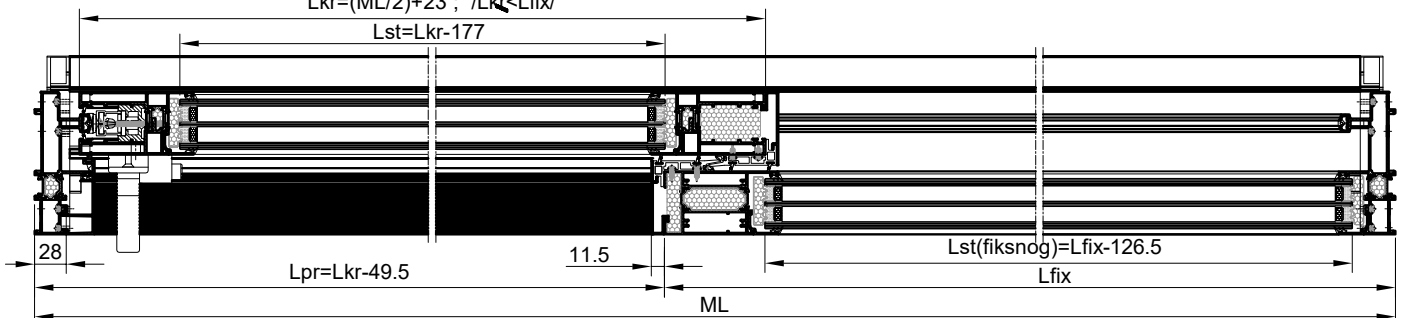

Profili Termo 120	Profili Termo 120-D	mjera	kom.	pilanje
Ram FT-0705	Ram FT-0722F	ML	2	45-45
Ram FT-0705	Ram FT-0722F	MH	2	45-45
Krilo FT-0710	Krilo FT-0725F	ML/4+50	4	45-45
Krilo FT-0710	Krilo FT-0725F	MH-79.5	4	45-45
Prečka FT-0715	Krilo FT-0730F	MH-46.5	2	90-90
Lajsna F-1529	Lajsna F-1528	Hkr	2	90-90
Lajsna F-1529	Lajsna F-1528	MH-56	2	90-90
Maska vanjska F-1231	Maska vanjska F-1231	ML-48	1	90-90
Lajsna F-0847	Lajsna F-1444	Lkr-89	4	90-90
Lajsna F-0846	Lajsna F-1445	MH-106	2	90-90
Staklo lajsna Z40-665	Staklo lajsna Z40-660	Lkr-157.2	4	90-90
Staklo lajsna Z40-665	Staklo lajsna Z40-660	Hkr-201	4	90-90
Staklo lajsna Z40-665	Staklo lajsna Z40-660	ML-(2Lpr+177)	2	90-90
Staklo lajsna Z40-665	Staklo lajsna Z40-660	MH-100	2	90-90
	Držač točkića F-1676	Lkr-50	4	90-90
Kutna spojnica 710.445			8	
Kutna spojnica 710.504			8	
Kutna spojnica 710.011			16	
Kutna spojnica 730.008			4	
Kutna spojnica 730.001			28	
Kutna spojnica 710.446* i **			4	
Kutna spojnica 710.478***			4	
Čep maske krila 375.016			4	
Odbojnik 375.020			4	
Čep profila maske F-1231 375.018			1 par	
Čep za odvod vode 370.070 *(**)			2	
Usmjerivač krila 373.061 *(**)			4	
Usmjerivač krila 373.060***			4	
Umetak sa četkicom 340.005*			2	
Umetak sa četkicom 340.402*			2	
Umetak sa četkicom 340.402**			2	
Umetak 363.019**			2	
Umetak sa četkicom 340.041***			2	
Gumeni umetak 360.015***			2	
Izolacijski umetak 340.042***			4Lkr	
Izolacijski umetak 340.044***			2Hkr	
Izolacijski umetak 340.045***			2Hkr	
Izolacijski umetak 340.013***			4Lkr+4Hkr+2Lfix+2MH	
Brtva prema staklu vanjska 321.002 (staklo 24 mm* i **)			4Lkr+4Hkr	
Brtva prema staklu vanjska 321.002 (staklo 24 mm* i **)			2Lfix+2MH	
Brtva prema staklu unutarnja 311.003 (staklo 24 mm* i **)			4Lkr+4Hkr	
Brtva prema staklu unutarnja 311.003 (staklo 24 mm* i **)			2Lfix+2MH	
Brtva prema staklu 311.001 (staklo 44 mm***)			8Lkr+8Hkr	
Brtva prema staklu 311.001 (staklo 44 mm***)			4Lfix+4MH	
Brtva vertikalnog pojasa krila 344.073			4Hkr	
Brtva u krilu 347.011**			4Lkr+4Hkr	
Brtva u krilu 347.012***			8Lkr+4Hkr	
Četkica u krilu 347.004*			8Lkr+4Hkr	
Četkica u krilu 347.004**			4Lkr	
Brtva na spoju dva krila 347.012			8Hkr	
Četkica 347.004			4Lkr+2Hkr	
Brtva u ramu 344.052			ML+2MH	
Brtva u ramu 344.015			4Lkr+2MH	
Vodilica F-1112			ML-103	1
Pvc umetak 374.075		Hkr	2	90-90
Pvc umetak 374.075		MH-46.5	2	90-90
Pvc umetak 374.042* i **		L=200 mm	4	90-90
Pvc umetak 374.052***		L=200 mm	4	90-90
PVC podmetač brave 374.028* i **		Hkr	2	90-90
PVC podmetač brave 374.060***		Hkr	2	90-90

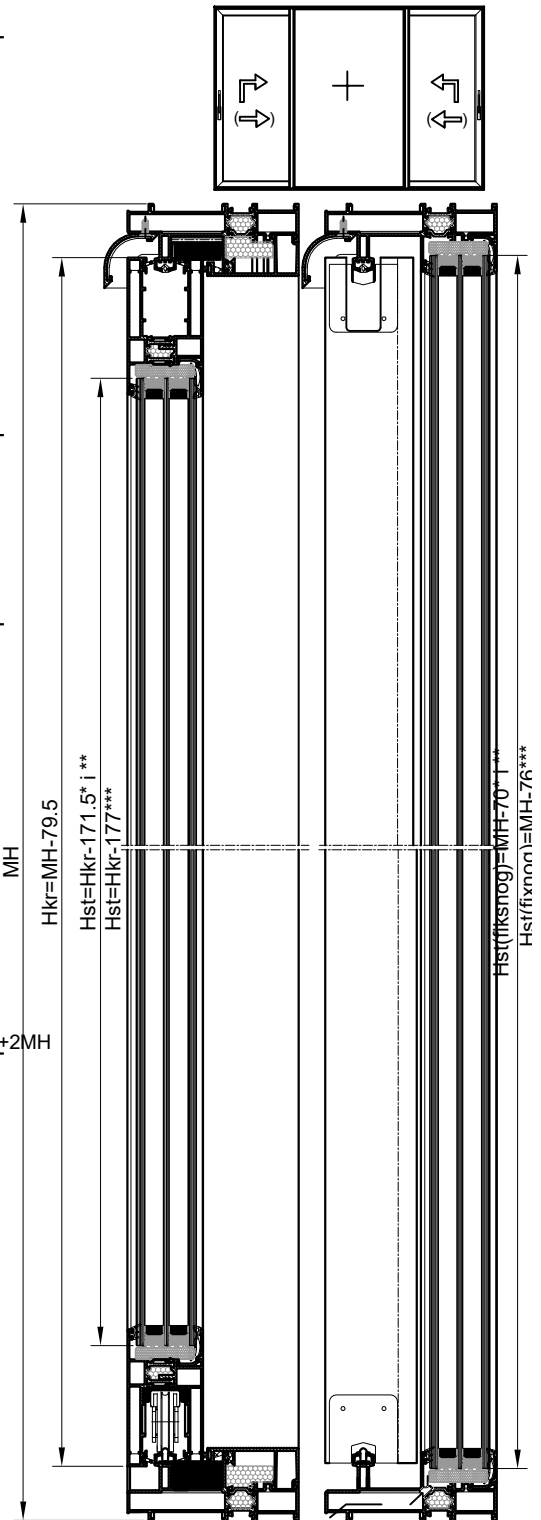

- \* koristi se za Termo 120 klizno
- \*\* koristi se za Termo 120 podizno klizno
- \*\*\* koristi se za Termo 120-D podizno klizno

- Okov za klizne i podizno klizne sisteme izabrati iz kataloga str.403.08.01.....

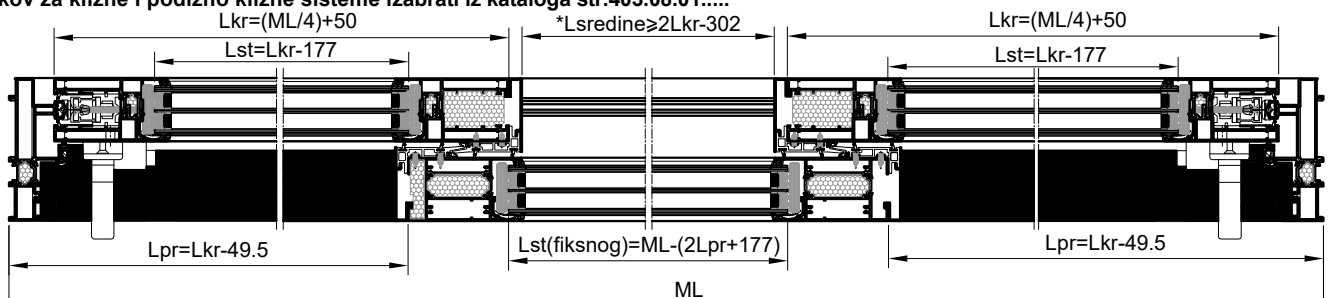

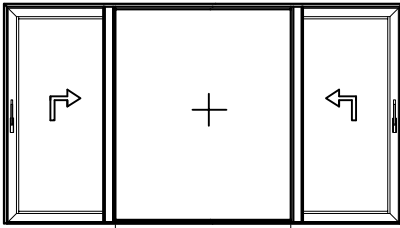

\*  $L_{sredine} \geq 2L_{kr}-302$

Profili				
Ram FT-0722F	.....	L	1	45-45
Ram FT-0722F	.....	H	2	45-90
Krilo FT-0725F	.....	$L_{kr}=(L/4)+50$	4	45-45
Krilo FT-0725F	.....	H-56	4	45-45
Lajsna F-1528	.....	H-56	2	90-90
Lajsna F-1528	.....	H-40.5	2	90-90
Prag F-1377	.....	L-62	1	90-90
Umetak praga F-1378	.....	L-62	1	90-90
Maska praga F-1381	.....	Lpr-64.2	2	90-90
Vodilica F-1379	.....	L-87.5	1	90-90
Gornja maska F-1380	.....	Lpr-39.4	2	90-90
Bočna lajsna F-1380	.....	H-65	2	90-90
Maska vanjska F-1231	.....	L-48	1	90-90
Prečka fiksnog dijela FT-0730F	.....	H-35.3	2	90-90
Staklo lajsna Z40-660	.....	$L_{kr}-157.2 ; L-2L_{pr}-201$	4 + 3	
Staklo lajsna Z40-660	.....	Hkr-201; H-40.5	4 + 2	90-90
Držač točkica F-1676	.....	Lkrila-50	4	90-90
<hr/>				
Kutna spojnica 710.445	.....		8	
Kutna spojnica 710.504	.....		8	
Kutna spojnica 710.011	.....		16	
Kutna spojnica 710.478	.....		2	
Kutna spojnica 730.008	.....		2	
Kutna spojnica 730.001	.....		10	
Umetak sa četkicom 340.041	.....		2	
Gumeni umetak 361.029	.....		2	
Čep maske krila 375.016	.....		2	
Čep maske krila-donji 375.066	.....		1	
Čep maske krila-donji 375.067	.....		1	
Odbojnik 375.020	.....		4	
Čep za profil maske F-1231 375.018	.....		1 par	
Usmjerivač krila 373.060	.....		4	
Čep praga 375.065	.....		1 par	
<hr/>				
Umetak za kotačiće 374.068	.....	Lkr	2	
Profil na spoju krila i fiksnog 374.075	.....	Hkr	2	
Profil na spoju krila i fiksnog 374.075	.....	H-40.5	2	
<hr/>				
Brtve za ostakljivanje 311.001	.....	$8L_{kr}+8H_{kr}+4L_{fix}+4H$		
Brtva krila prema pragu 344.054	.....	4 Lkr		
Brtva u pragu za masku 344.055	.....	2Lpr		
Brtva u utoru rama 344.052	.....	L+2H		
Brtva za masku F-1380 344.015	.....	$2L_{kr}+2H$		
Brtva u vertikalnom pojasu krila 347.012	.....	$4L_{kr}+4H_{kr}$		
Brtva na spoju krila i fiksnog 344.073	.....	4H		
Brtva na spoju krila i fiksnog 347.012	.....	8Hkr		
Četkica 347.004	.....	$4L_{kr}+2H_{kr}$		
Izolacijski umetak ispod stakla 340.013	.....	$4(L_{kr}-156)-4(H_{kr}-180)$		
Izolacijski umetak ispod stakla 340.013	.....	$2(L-2L_{pr}-156)-2(H-64)$		
Izolacijski umetak 340.042	.....	2Lkr		
Izolacijski umetak 340.044	.....	$2(H_{kr}-115)$		
Izolacijski umetak 340.045	.....	$2(H-40.5)$		
PVC podmetač brave 374.060	.....	Hkr	2	90-90
<hr/>				
$L_{stkrila} \times H_{stkrila} = (L_{kr}-177) \times (H_{kr}-177)$			kom.2	
$L_{stfixnog} \times H_{stfixnog} = L-(2L_{pr}+177) \times (H-60)$			kom.1	

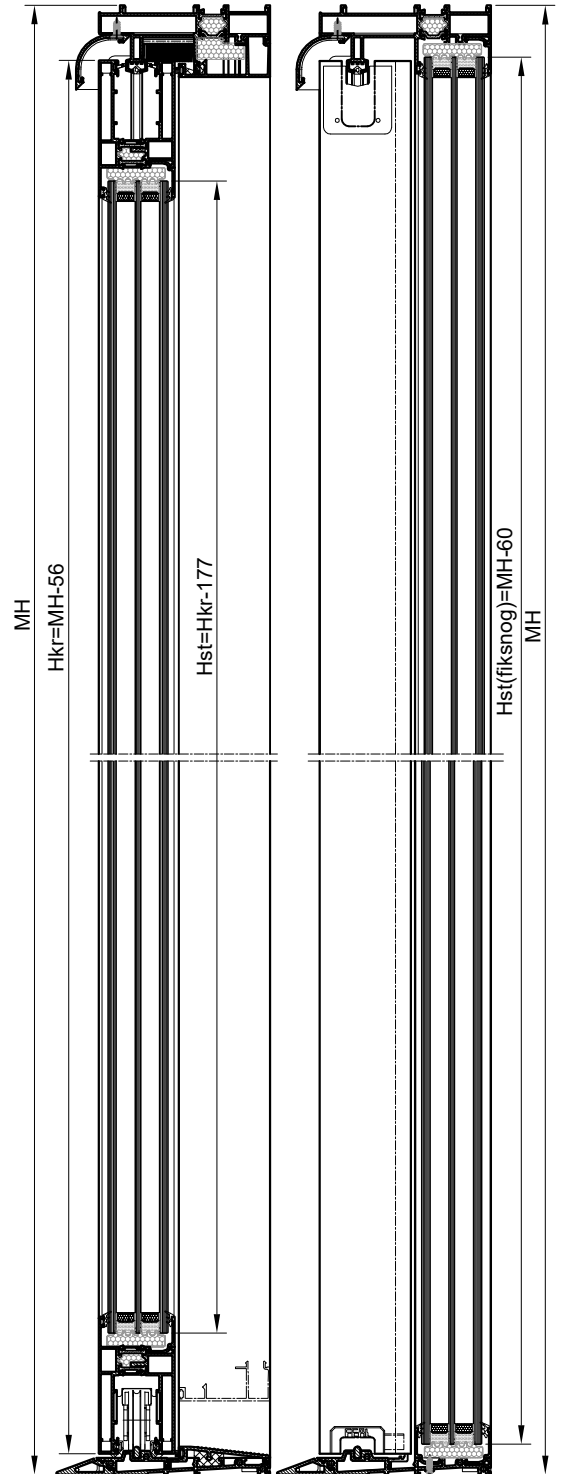

- Okov za klizne i podizno klizne sisteme  
izabrati iz kataloga str.403.08.01.....

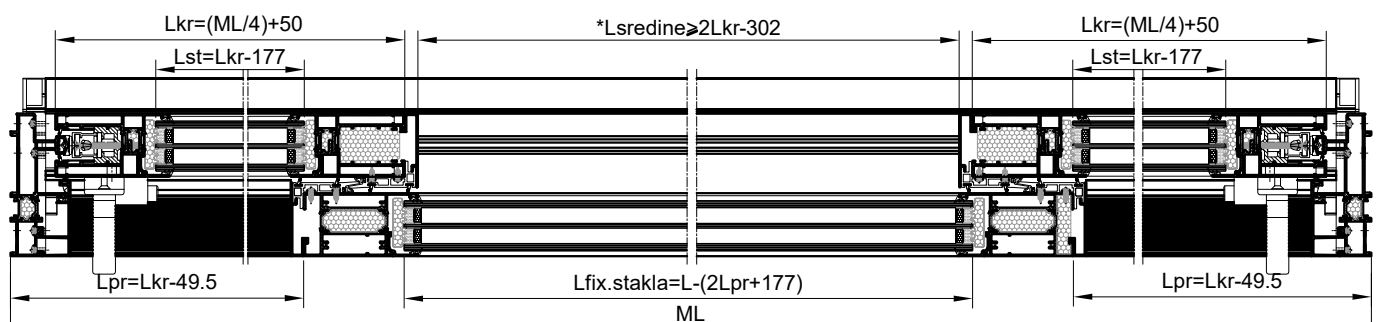

Profili Termo 120	Profili Termo 120-D	mjera	kom.	pilanje
Ram FT-0705	Ram FT-0722F	ML	2	45-45
Ram FT-0705	Ram FT-0722F	MH	2	45-45
Krilo FT-0710	Krilo FT-0725F	ML/4+44	2	45-45
Krilo FT-0710	Krilo FT-0725F	MH-79.5	2	45-45
Prečka FT-0715	Krilo FT-0730F	MH-46.5	2	90-90
Spojnica FT-0717	Spojnica FT-0733F	MH-79.5	1	90-90
Lajsna F-1529	Lajsna F-1528	Hkr	2	90-90
Lajsna F-1529	Lajsna F-1528	MH-56	2	90-90
Maska vanjska F-1231	Maska vanjska F-1231	ML-48	1	90-90
Lajsna F-0847	Lajsna F-1444	Llp=Lkr-199	2	90-90
Staklo lajsna Z40-665	Staklo lajsna Z40-660	Lkr-157.2	4	90-90
Staklo lajsna Z40-665	Staklo lajsna Z40-660	Hkr-201	4	90-90
Staklo lajsna Z40-665	Staklo lajsna Z40-660	Lfix-106.6	4	90-90
Staklo lajsna Z40-665	Staklo lajsna Z40-660	MH-100	4	90-90
	Držač točkica F-1676	Lkrila-50	4	90-90
<hr/>				
Kutna spojnica 710.445			8	
Kutna spojnica 710.504			8	
Kutna spojnica 710.011			16	
Kutna spojnica 730.008			4	
Kutna spojnica 730.001			28	
Kutna spojnica 710.446* i **			4	
Kutna spojnica 710.478***			4	
Čep maske krila 375.016			4	
Odbojnik 375.020			4	
Čep profila maske F-1231 375.018			1 par	
Čep za odvod vode 370.070 (***)			2	
Usmjerivač krila 373.061 (***)			4	
Usmjerivač krila 373.060***			4	
Umetak sa četkicom 340.005*			2	
Umetak sa četkicom 340.402*			2	
Umetak sa četkicom 340.402**			2	
Umetak 363.019**			2	
Umetak sa četkicom 340.041***			2	
Gumeni umetak 360.015***			2	
Izolacijski umetak 340.042***			2Llp	
Izolacijski umetak 340.044***			2Hkr	
Izolacijski umetak 340.045***			2Hkr	
Izolacijski umetak 340.013***			4Lkr+4Hkr+4Lfix+2Hkr	
Brtva prema staklu vanjska 321.002 (staklo 24 mm* i **)			4Lkr+4Hkr	
Brtva prema staklu vanjska 321.002 (staklo 24 mm* i **)			4Lfix+4MH	
Brtva prema staklu unutarnja 311.003 (staklo 24 mm* i **)			4Lkr+4Hkr	
Brtva prema staklu unutarnja 311.003 (staklo 24 mm* i **)			4Lfix+4MH	
Brtva prema staklu 311.001 (staklo 44 mm***)			8Lkr+8Hkr	
Brtva prema staklu 311.001 (staklo 44 mm***)			8Lfix+8MH	
Brtva vertikalnog pojasa krila 344.073			4Hkr	
Brtva u krilu 347.011**			4Lk+2Hkr	
Brtva u krilu 347.011***			4Hkr	
Brtva u krilu 347.012***			8Lkr	
Četkica u krilu 347.004*			8Lkr+4Hkr+2Llp	
Četkica u krilu 347.004**			4Lkr+2Llp	
Četkica u krilu 347.004***			2Llp	
Brtva na spoju krila i fiksnog 347.012			8Hkr	
Brtva u ramu 344.052			ML+2MH	
Brtva u ramu 344.015			2Llp	
Vodilica F-1112			ML-103	1
Pvc umetak 374.075			Hkr	2 90-90
Pvc umetak 374.075			MH-46.5	2 90-90
Pvc umetak 374.042* i **			L=200 mm	4 90-90
Pvc umetak 374.052***			L=200 mm	4 90-90
PVC podmetač brave 374.028* i **			Hkr	2 90-90
PVC podmetač brave 374.060***			Hkr	2 90-90

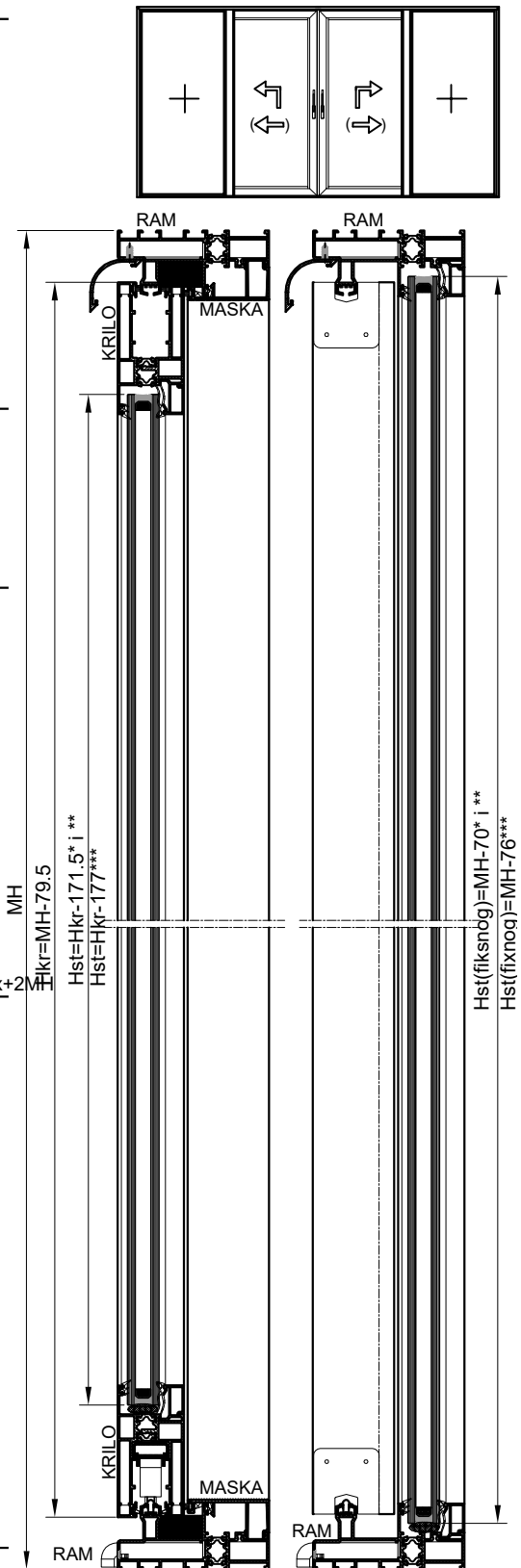

- Okov za klizne i podizno klizne sisteme  
izabrati iz kataloga str.403.08.01.....

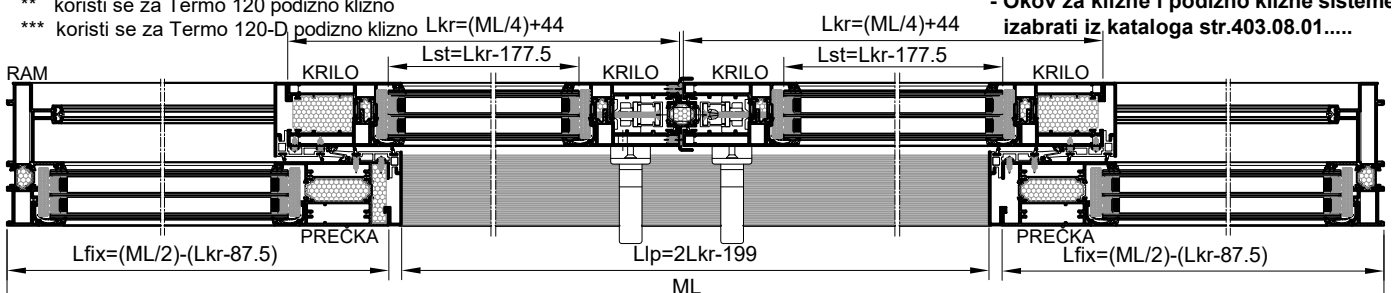

### Profili

Ram FT-0722F	ML	1	45-45
Ram FT-0722F	MH	2	45-90
Kriilo FT-0725F	$Lkr=(ML/4)+44$	4	45-45
Kriilo FT-0725F	MH-56	4	45-45
Lajsna F-1528	MH-56	2	90-90
Lajsna F-1528	MH-40.5	2	90-90
Prag F-1377	ML-62	1	90-90
Umetak praga F-1378	ML-62	1	90-90
Maska praga F-1381	2Lkr-199	1	90-90
Vodilica F-1379	ML-87.5	1	90-90
Gornja maska F-1380	2Lkr-199	1	90-90
Maska vanjska F-1231	ML-48	1	90-90
Prečka fiksnog dijela FT-0730F	MH-35.3	1	90-90
Umetak FT-0733F	MH-56	1	90-90
Staklo lajsna Z40-660	Lkr-157.2 ; Lfix-150.6	4 + 6	
Staklo lajsna Z40-660	Hkr-201; MH-40.5 4 + 4	90-90	
Staklo lajsna Z40-660	Hkr-201; MH-40.5 4 + 4	90-90	
Držač točkica F-1676	Lkrila-50	4	90-90
<hr/>			
Kutna spojnica 710.445		8	
Kutna spojnica 710.504		8	
Kutna spojnica 710.011		16	
Kutna spojnica 710.478		2	
Kutna spojnica 730.008		2	
Kutna spojnica 730.001		10	
<hr/>			
Umetak sa četkicom 340.041		2	
Gumeni umetak 361.029		2	
Čep maske krila 375.016		2	
Čep maske krila-donji 375.066		1	
Čep maske krila-donji 375.067		1	
Odbojnik 375.020		4	
Čep za profil maske F-1231 375.018		1 par	
Usmjerivač krila 373.060		4	
Čep praga 375.065		1 par	
<hr/>			
Umetak za kotačiće 374.068	Lkr	2	
Umetak za bravu 374.060	Hkr	2	
Profil na spoju krila i fiksnog 374.075	Hkr	2	
Profil na spoju krila i fiksnog 374.075	H-40.5	2	
<hr/>			
Brtve za ostakljivanje 311.001	8Lkr+8Hkr+8Lfix+8H		
Brtva krila prema pragu 344.054	4 Lkr		
Brtva u pragu za masku 344.055	2Lkr		
Brtva u utoru rama 344.052	L+2H		
Brtva za masku F-1380 344.015	2Lkr		
Brtva u krilu 347.012	4Lkr		
Brtva u krilu 347.011	4Hkr		
Brtva na spoju krila i fiksnog 344.073	4H		
Brtva na spoju krila i fiksnog 347.012	8Hkr		
Četkica 347.004	2Lkr		
<hr/>			
Izolacijski umetak ispod stakla 340.013	4(Lkr-156)-4(Hkr-180)		
Izolacijski umetak ispod stakla 340.013	4(Lfix-106)-4(H-64)		
Izolacijski umetak 340.042	2Lkr		
Izolacijski umetak 340.044	2Hkr-115		
Izolacijski umetak 340.045	2H-40.5		
PVC podmetač brave 374.060	Hkr	2	90-90
<hr/>			
Lstkrila x Hstkrila = (Lkr-177) x (Hkr-177)		kom.2	
Lstfiksno x Hstfiksno = (Lfix-126.5) x (H-60)		kom.2	

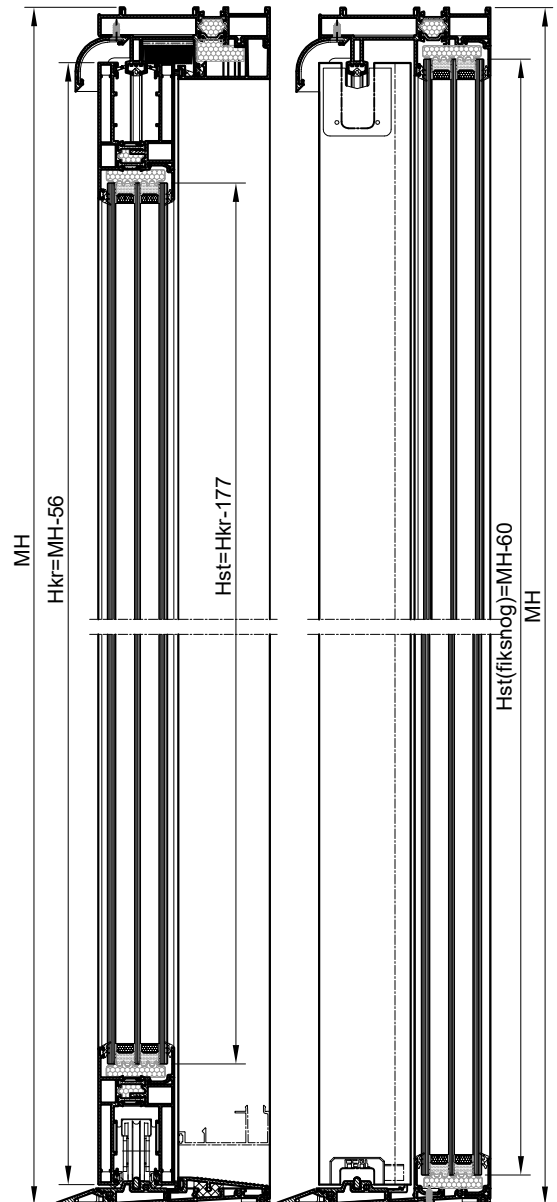
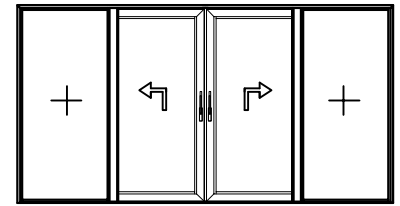

- Okov za podizno klizne sisteme izabrati iz kataloga str.403.08.01.....

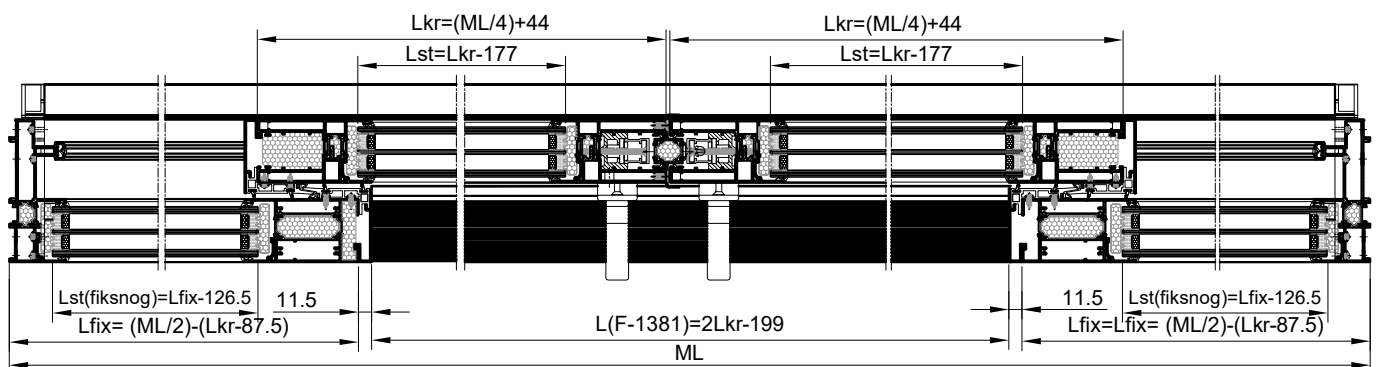

Profili	mjera	kom.	pilanje
Ram FT-0705	ML	2	45-45
Ram FT-0705	MH	2	45-45
Krilo FT-0711	ML/2+15	2	45-45
Krilo FT-0711	MH-81.5	2	45-45
Prečka FT-0716	MH-46.5	1	90-90
Lajsna F-1529	Hkr	1	90-90
Lajsna F-1529	MH-46.5	1	90-90
Maska vanjska F-1231	ML-48	1	90-90
Lajsna F-0847	Lkr-66.5	2	90-90
Lajsna F-0846	MH-106	1	90-90
Staklo lajsna Z40-665	Lkr-116	2	90-90
Staklo lajsna Z40-665	Hkr-160	2	90-90
Staklo lajsna Z40-665	Lfix-86.5	2	90-90
Staklo lajsna Z40-665	MH-100	2	90-90
Kutna spojnica 710.520		4	
Kutna spojnica 710.519		4	
Kutna spojnica 731.010		4	
Kutna spojnica 730.017		8	
Kutna spojnica 710.011		8	
Kutna spojnica 730.008		4	
Kutna spojnica 730.001		16	
Kutna spojnica 710.446		4	
Čep maske krila 375.016		2	
Odbojnik 375.020		2	
Čep profila maske F-1231 375.018		1 par	
Čep za odvod vode 370.070		2	
Umetak sa četkicom 340.005*		2	
Umetak sa četkicom 340.402**		2	
Gumeni umetak 363.019**		2	
Usmjerivač krila 373.061 *(**)		2	
Brтва prema staklu vanjska 321.002 (staklo 24 mm)	2Lkr+2Hkr		
Brтва prema staklu vanjska 321.002 (staklo 24 mm)	2Lfix+2MH		
Brтва prema staklu unutarnja 311.003 (staklo 24 mm)	2Lkr+2Hkr		
Brтва prema staklu unutarnja 311.003 (staklo 24 mm)	2Lfix+2MH		
Brтва vertikalnog pojasa krila 344.073	2Hkr		
Brтва u krilu 347.011**	2Lkr+2Hkr		
Četkica u krilu 347.004*	4Lkr+2Hkr		
Četkica u krilu 347.004**	2Lkr		
Četkica u krilu 347.004	2Llp+1MH	90-90	
Brтва na spoju krila i fiksnog 347.012	4Hkr	90-90	
Brтва u ramu 344.052	ML+2MH	90-90	
Brтва u ramu 344.015	2Lkr+MH	90-90	
Vodilica F-1112	ML-102	1	
Pvc umetak 374.075	Hkr	1	
Pvc umetak 374.075	MH-46.5	1	
Pvc umetak 374.096***	L=200 mm	2	

- Okov za klizne i podizno klizne sisteme izabrati iz kataloga str.403.08.01.....

\* koristi se za Termo 120 plus klizno

\*\* koristi se za Termo 120 plus podizno klizno

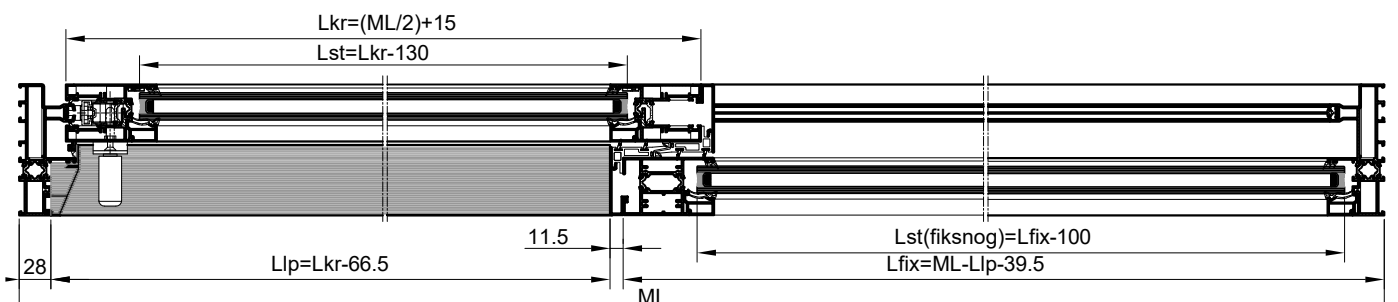
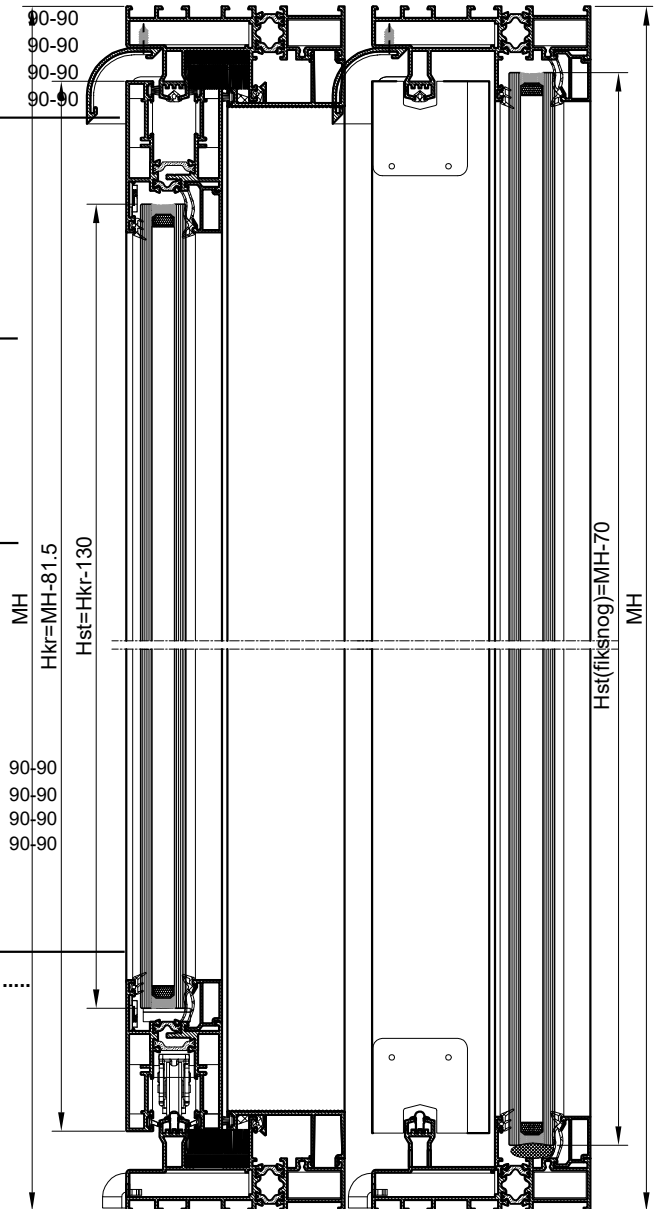
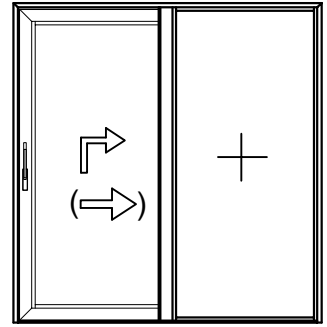

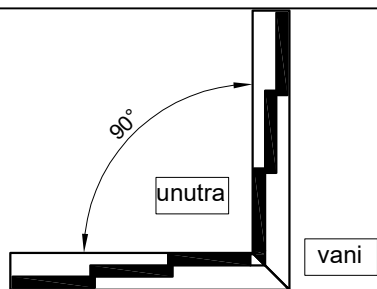

naziv	mjera	kom.	pilanje
Ram FT-0721F	L1	2	45-90
Ram FT-0721F	L2	2	45-90
Ram FT-0721F	H	2	45-45
Krilo FT-0725F	L1/3-20	6	45-45
Krilo FT-0725F	L2/3-20	6	45-45
Krilo FT-0725F	H-82	12	45-45
Umetak FT-0732F	Hkr-40	1	90-90
Umetak F-1532	Hkr-40	1	90-90
Umetak F-1531	Hkr-40	1	90-90
Lajsna F-1528	Hkr	8	90-90
Maska vanjska F-1231	L1-22.2	1	90-90
Maska vanjska F-1231	L2-22.2	1	90-90
Staklo lajsna Z40-660	Lkr-157.2	12	90-90
Staklo lajsna Z40-660	Hkr-201	12	90-90
Držač točkica F-1676	Lkila-50	12	90-90
Kutna spojnica 710.445		24	
Kutna spojnica 710.504		24	
Kutna spojnica 710.011		48	
Kutna spojnica 730.013		8	
Kutna spojnica 730.001		72	
Umetak sa četkicom 340.046		4	
Gumeni umetak 360.014		4	
Čep maske krila 375.016		16	
Odbojnik 375.020		8	
Usmjerivač krila 373.060		12	
Čep za profil maske F-1231 375.018		1 par	
Čep za odvod vode 370.070		4	
Umetak 340.044		4 Hkr	
Čep na umetku za spoj dva krila 363.049		2 para	
Brtva prema staklu vanjska 321.002 (staklo 44 mm)	H	12	
Brtva prema staklu vanjska 321.002 (staklo 44 mm)	Lkr	12	
Brtva vertikalnog pojasa krila 344.073	Hkrila	8	
Brtva prema staklu unutarnja 311.003 (staklo 44 mm)	H	12	
Brtva prema staklu unutarnja 311.003 (staklo 44 mm)	Lkr	12	
Brtva na spoju dva krila 347.012	16 Hkr		
Brtva 347.012	24 Lkr+5Hkr		
Ispuna 340.013	12Lkr+12Hkr		
374.051	H-40.5	4	45-45
374.051	(L1-20.5)+(L2-20.5)	2+2	
374.052 za HS-250 i Alu-HS 300	L=200 mm	12	90-90 45-45
374.075	Hkr	8	90-90
Al vodilica F-1112	(L1-51)	3	90-90
Al vodilica F-1112	(L2-51)	3	90-90
Brtva rama 344.052	L-104	3	90-90
Brtva rama 344.052	H-100	6	90-90
Brtva za spoj pod 90° 344.075	3(Hkr-40)	3	90-90
Pvc podmetač brave 374.060	Hkr	7	90-90

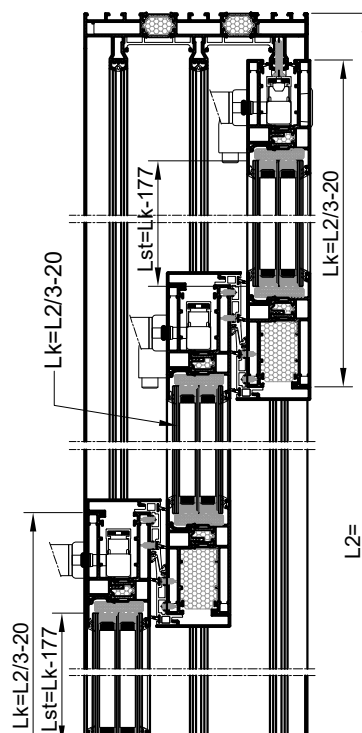
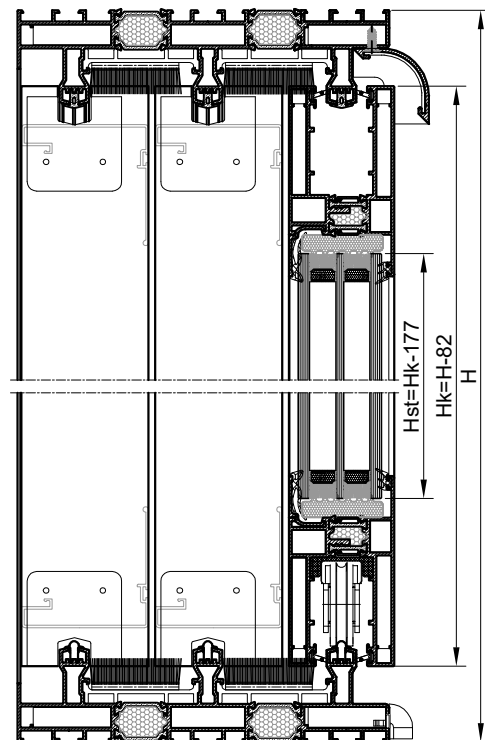

- Okov za podizno klizne sisteme izabrati iz kataloga str.403.08.01.....

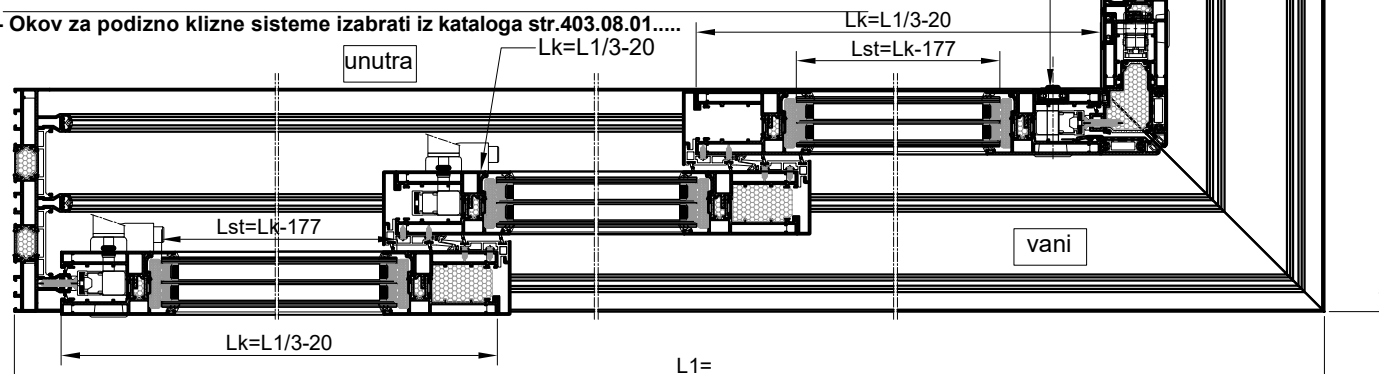

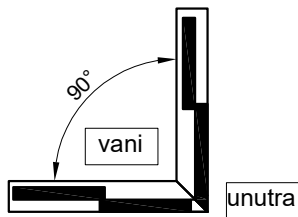

naziv	mjera	kom.	pilanje
Ram FT-0720F	L1	2	45-90
Ram FT-0720F	L2	2	45-90
Ram FT-0720F	H	2	45-45
Krilo FT-0725F	L1/2-6.5	4	45-45
Krilo FT-0725F	L2/2-6.5	4	45-45
Krilo FT-0725F	H-82	8	45-45
Umetak FT-0732F	Hkr-40	1	90-90
Umetak F-1532	Hkr-40	1	90-90
Umetak F-1531	Hkr-40	1	90-90
Lajsna F-1528	Hkr	4	90-90
Maska vanjska F-1231	L1-128.5	1	90-90
Maska vanjska F-1231	L2-128.5	1	90-90
Staklo lajsna Z40-660	Lkr-157.2	8	90-90
Staklo lajsna Z40-660	Hkr-201	8	90-90
Držač točkica F-1676	Lkr-50	8	90-90
<hr/>			
Kutna spojnica 710.445		16	
Kutna spojnica 710.504		16	
Kutna spojnica 710.011		32	
Kutna spojnica 730.013		8	
Kutna spojnica 730.001		48	
<hr/>			
Umetak sa četkicom 340.046		2	
Gumeni umetak 360.014		2	
Čep maske krila 375.016		8	
Odbojnik 375.020		4	
Usmjerivač krila 373.060		8	
Čep za profil maske F-1231 375.018		1 par	
Čep za odvod vode 370.070		4	
Umetak 340.044		3 Hkr	
Čep na umetku za spoj dva krila 363.049		2 para	
<hr/>			
Brtva prema staklu vanjska 321.002 (staklo 44 mm)	H	8	
Brtva prema staklu vanjska 321.002 (staklo 44 mm)	Lkr	8	
Brtva vertikalnog pojasa krila 344.073	Hkrila	4	
Brtva prema staklu unutarnja 311.003 (staklo 44 mm)	H	8	
Brtva prema staklu unutarnja 311.003 (staklo 44 mm)	Lkr	8	
Brtva na spoju dva krila 347.012	8 Hkr		
Brtva 347.012	16 Lkr +5 Hr		
Ispuna 340.013	8Lkr+8Hkr		
374.051	H-40.5	2	45-45
374.051	(L1-20.5)+(L2-20.5)	1+1	45-45
374.052 za HS-250 i Alu-HS 300	L=200 mm	8	90-90
374.075	Hkr	4	90-90
Al vodilica F-1112	(L1-51)	2	90-90
Al vodilica F-1112	(L2-51)	2	90-90
Brtva rama 344.052	(L1-51)+(L2-51)	2+2	90-90
Brtva rama 344.052	H-100	4	90-90
Brtva za spoj pod 90° 344.075	3(Hkr-40)	3	90-90
Pvc podmetač brave 374.060	Hkr	4	90-90

- Okov za podizno klizne sisteme izabrati iz kataloga str.403.08.01.....

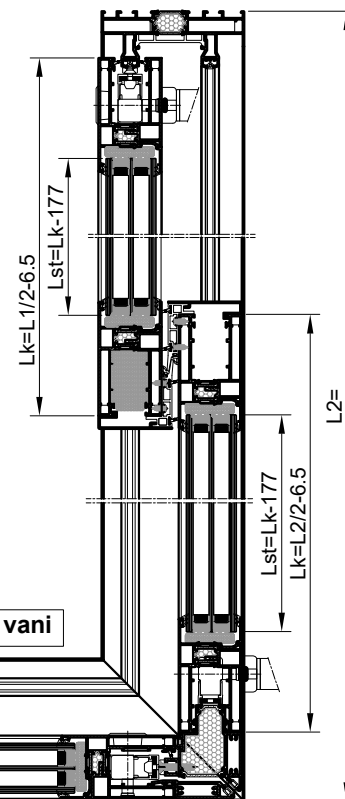
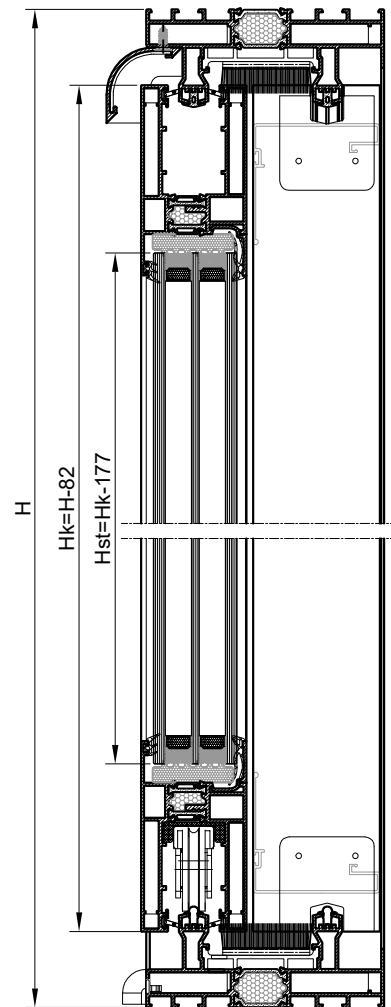
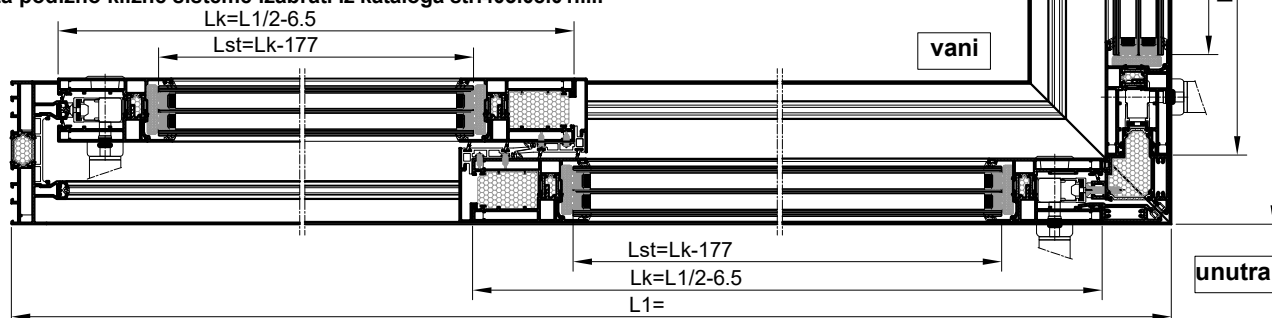



# FEAL

## TERMO 120

Knjiga B / *Book B*

Siječanj 2020. / *January 2020*

FEAL d.o.o.

Trnska cesta 146

88220 Široki Brijeg

Bosna i Hercegovina

Tel. +387 39 704-269; 705-807; 705-636

Fax. +387 39 704-358

[info@feal.ba](mailto:info@feal.ba)

[www.feal.ba](http://www.feal.ba)