

FEAL

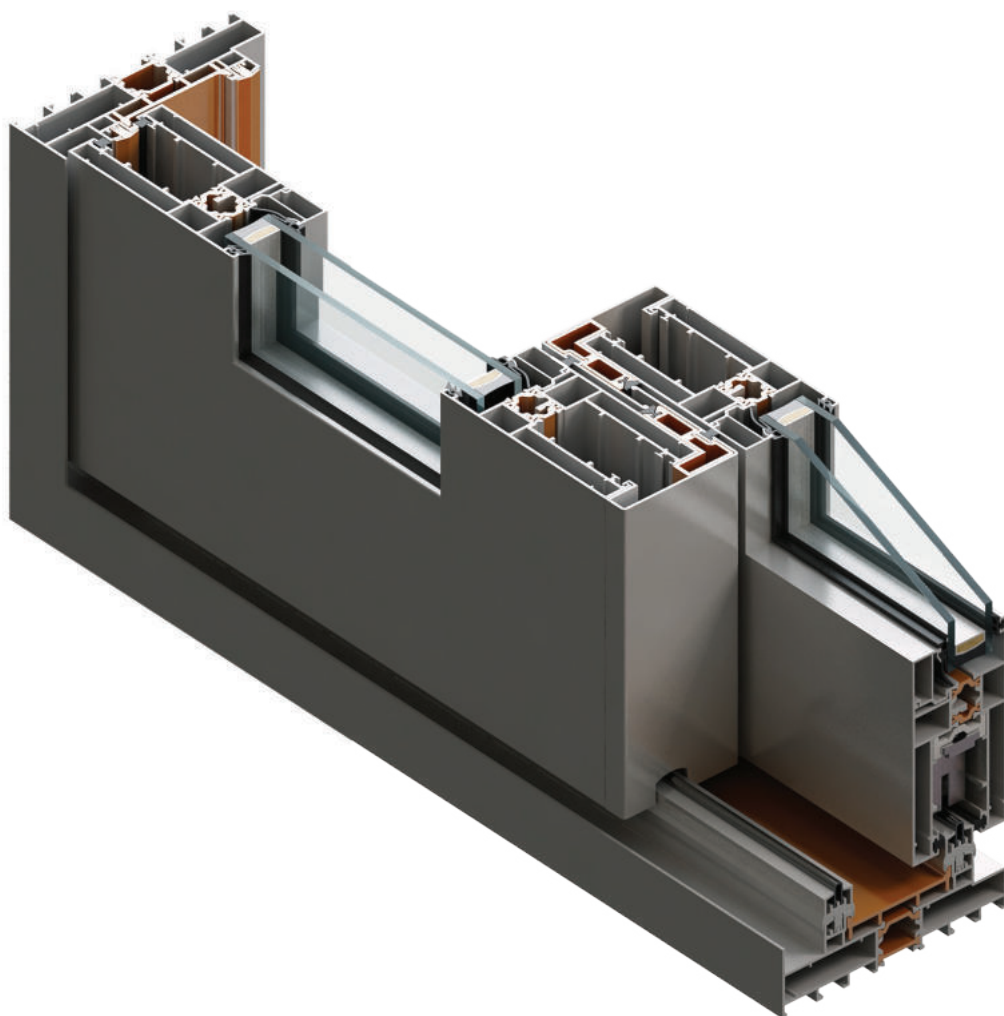

TERMO 120

PODIZNO-KLIZNA VRATA
LIFT & SLIDE DOORS

Knjiga A / *Book A*

SADRŽAJ

CONTENT

01	ZNAČAJKE SISTEMA	403.01.000
01	SYSTEM CHARACTERISTICS	403.01.000
02	ISPITIVANJA I CERTIFIKATI	403.02.000
02	TESTING AND CERTIFICATES	403.02.000
03	PROFILI	403.03.000
03	PROFILES	403.03.000
04	PRIKAZ STAKLJENJA	403.04.000
04	GLAZING	403.04.000
05	PRESJECI TERMO 120	403.05.000
05	CROSS SECTIONS TERMO 120	403.05.000
05	PRESJECI TERMO 120 plus	403.05.100
05	CROSS SECTIONS 120 plus	403.05.100
05	PRESJECI SPOJEVI S DRUGIM SISTEMIMA I RAL UGRADNJA	403.05.200
05	CROSS SECTIONS WITH OTHER SYSTEMS AND RAL INSTALLATION	403.05.200

Presjeci s kliznim krilom FT-0725
Cross-sections with sliding sash FT-0725

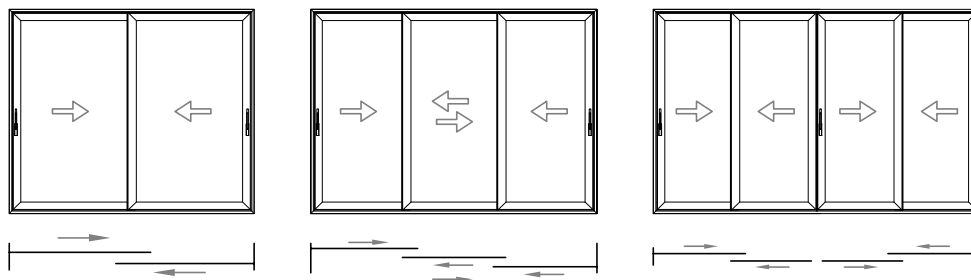

Presjeci s kliznim krilom FT-0727
Cross-sections with sliding sash FT-0727

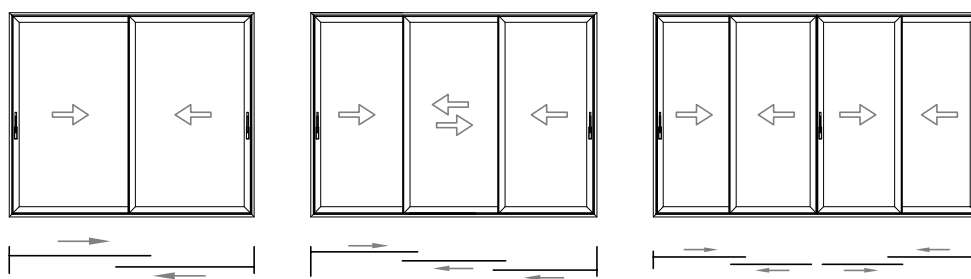

Presjeci s podiznom-kliznim krilom FT-0725
Cross-sections with lift-slide sash FT-0725

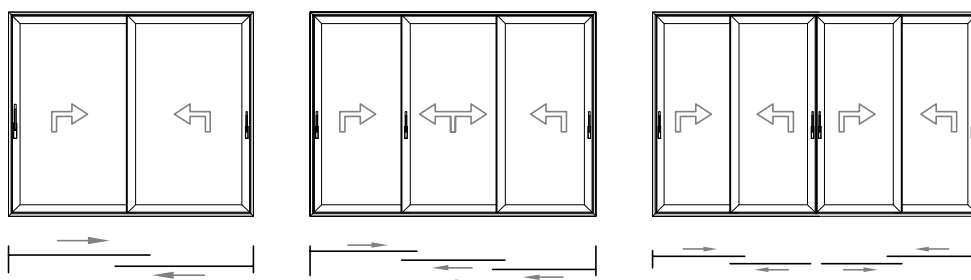

Presjeci s podiznom-kliznim krilom FT-0727
Cross-sections with lift-slide sash FT-0727

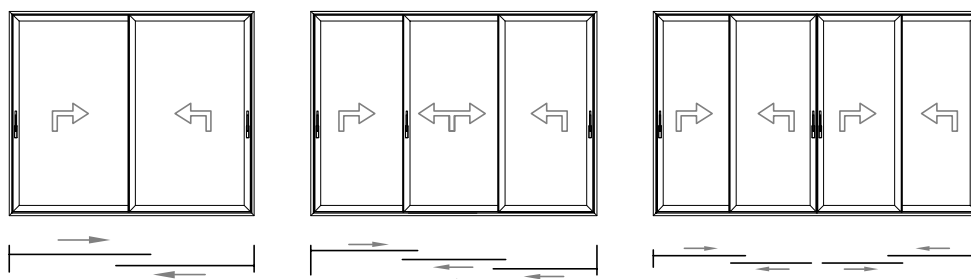

Presjeci s kliznim krilom FT-0725 i integriranim fiksnim poljem Sections with FT-0725 sliding sash and integrated fixed field

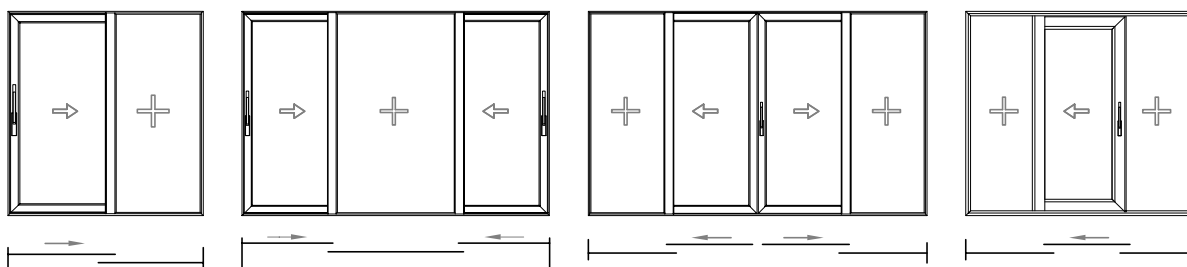

Presjeci s kliznim krilom FT-0727 i integriranim fiksnim poljem Sections with FT-0727 sliding sash and integrated fixed field

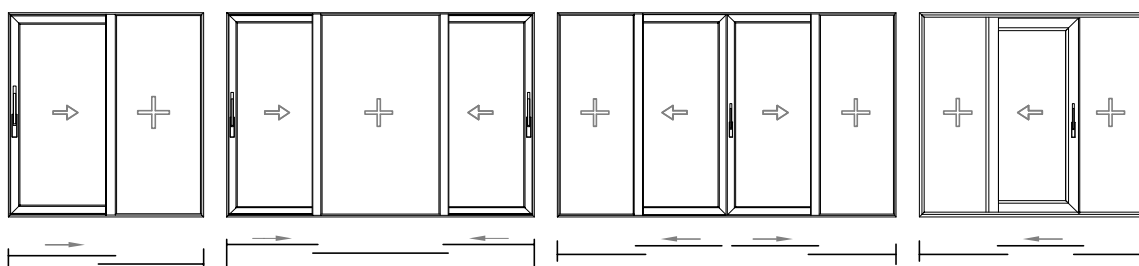

Presjeci s podizno-kliznim krilom FT-0725 i integriranim fiksnim poljem Sections with lift-slide sash FT-0725 and integrated fixed field

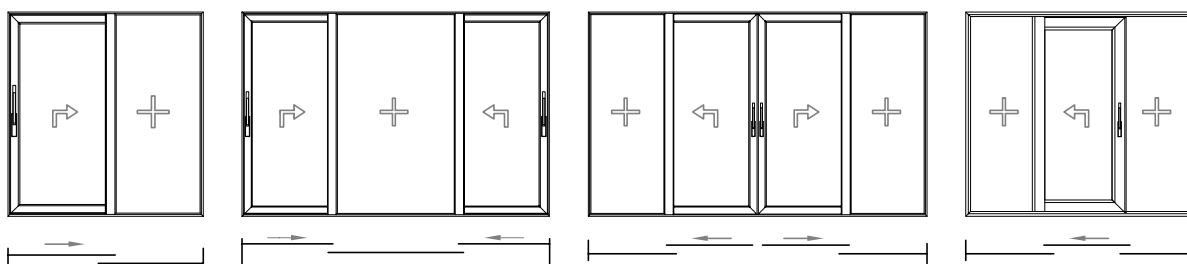

Presjeci s podizno-kliznim krilom FT-0727 i integriranim fiksnim poljem Sections with lift-slide sash FT-0727 and integrated fixed field

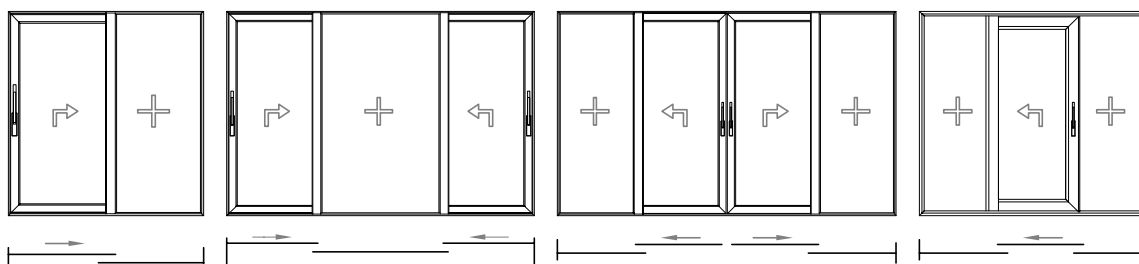

Presjeci s krilom FT-0727 + FT-0728 sa uskim
srednjim vertikalnim pojasom
Sash sections FT-0727 + FT-0728 with narrow
middle vertical zone

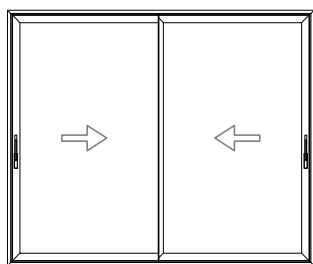

Klizno krilo Slide sash

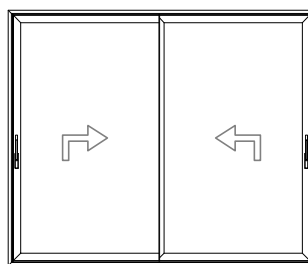

Podizno-klizno krilo
Lift & Slide sash

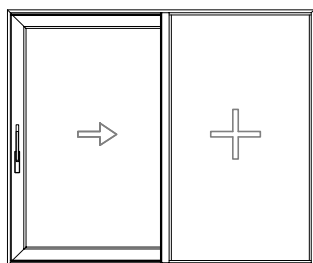

Klizno krilo s integriranim
fiksniim poljem
Slide sash with integrated
fixed field

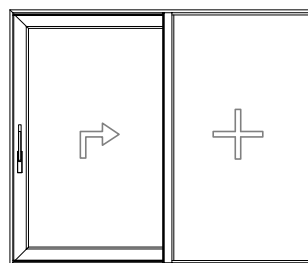

Podizno-klizno krilom s
integriranim fiksniim poljem
Lift & Slide sash with
integrated fixed field

Značajke sistema

System characteristics

Termo 120
klizno/podizno klizno
Termo 120
sliding/lift and sliding

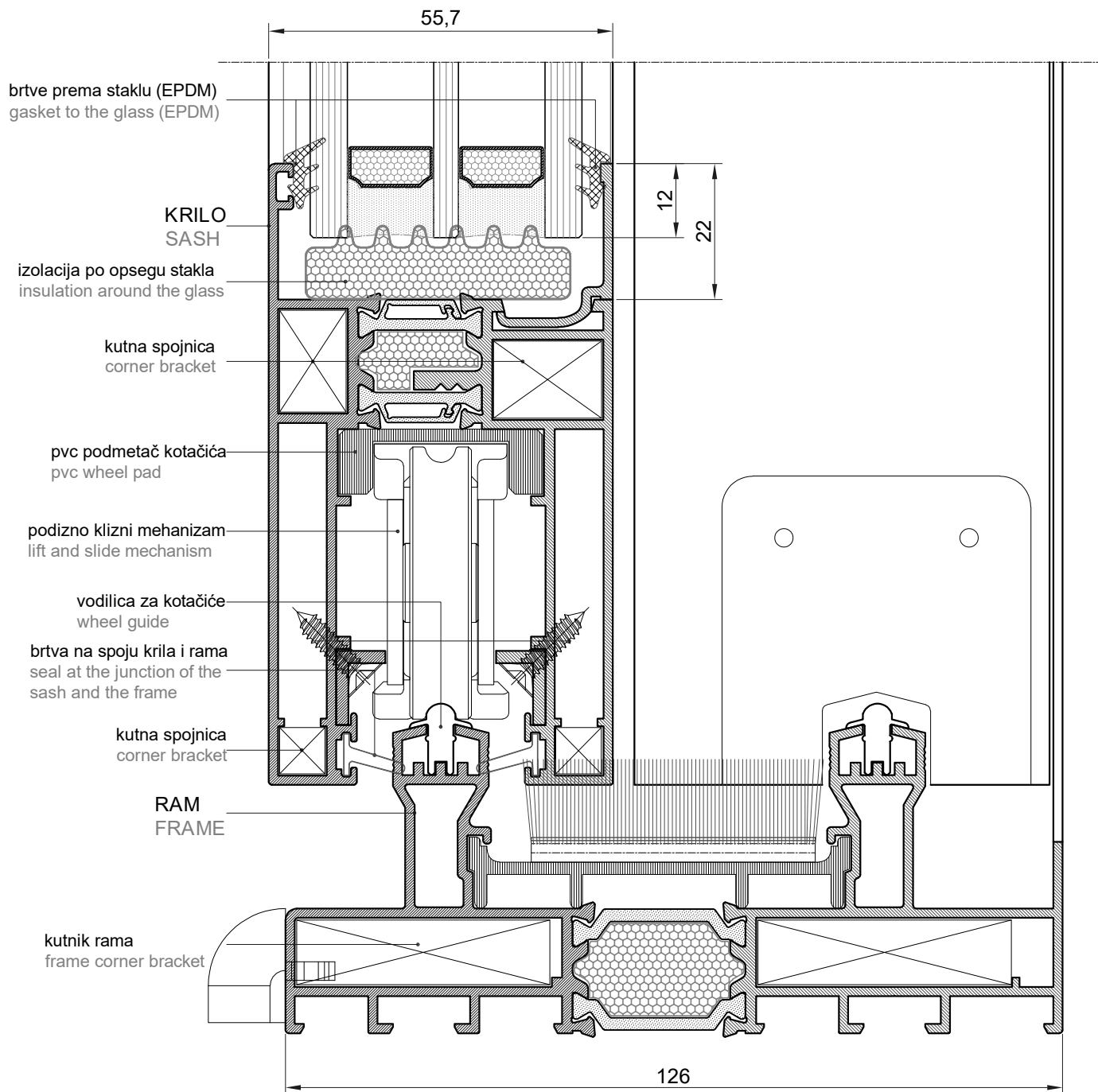

Klizni / Podizno klizni sistem:
Slide/Lift and slide system:

- RAM: - dvije staze (FT-0720F)
- tri staze (FT-0721F)
- FRAME: - two paths (FT-0720F)
- three paths (FT-0721F)
- KRILLO: - FT-0725 F - okov Hautau
- FT-0727 - okov Hautau
- FT-0728 - okov Hautau
- SASH: - FT-0725 F - Hautau's mechanism
- FT-0727 - Hautau's mechanism
- FT-0728 - Hautau's mechanism

Termo 120 plus
klizno/podizno klizno
Termo 120 plus
sliding/lift and sliding

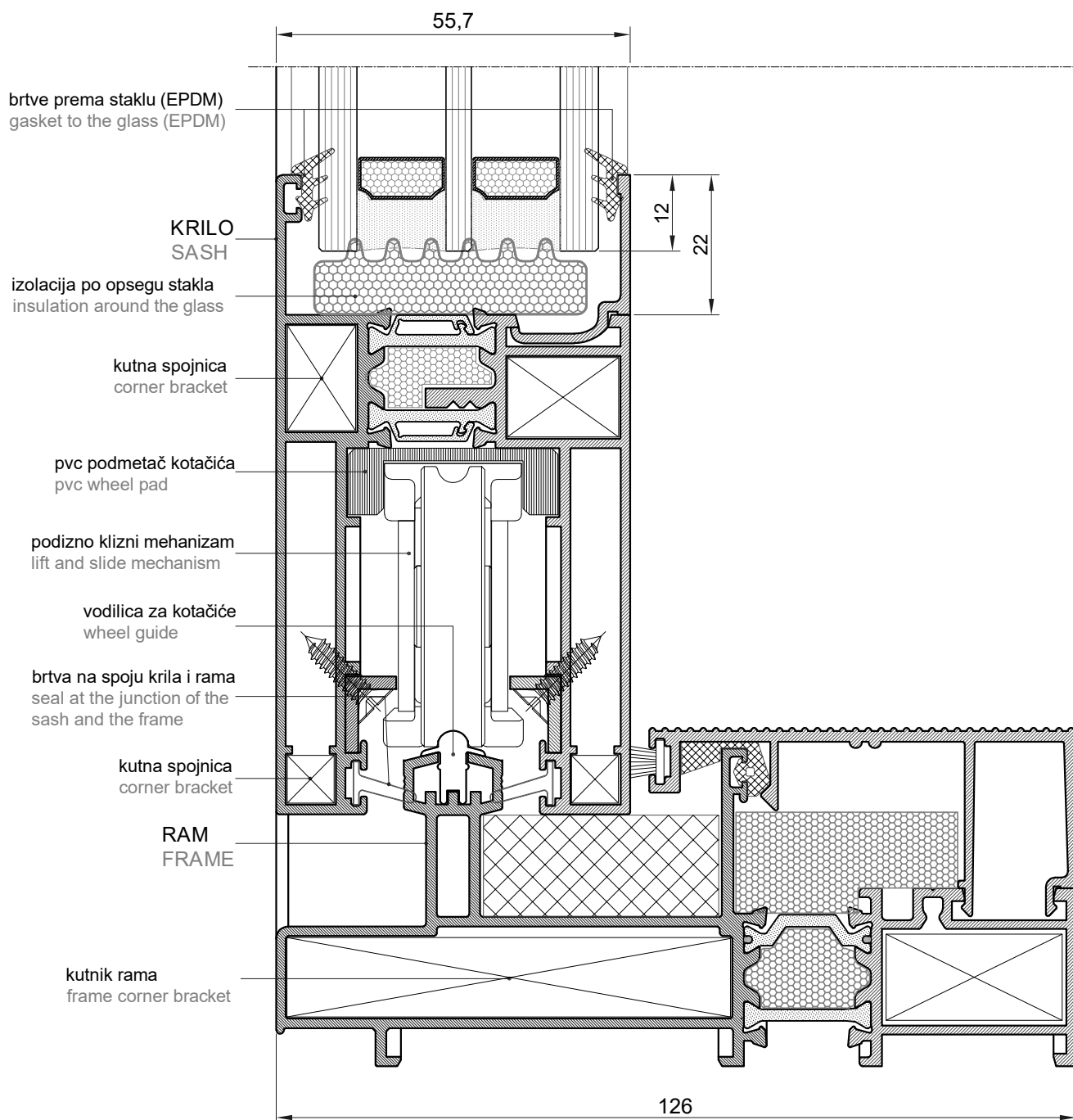

Klizni / Podizno klizni sistem:
Slide/Lift and slide system:

RAM: - sa integriranim fiksnim dijelom (FT-0722F)
FRAME: - with integrated fixed part (FT-0722F)

KRILLO: - FT-0725 F - okov Hautau
- FT-0727 - okov Hautau
- FT-0728 - okov Hautau

SASH: - FT-0725 F - Hautau's mechanism
- FT-0727 - Hautau's mechanism
- FT-0728 - Hautau's mechanism

OPIS SISTEMA TERMO 120
DESCRIPTION OF SYSTEM TERMO 120

Sistem se koristi za izradu kliznih/podizno-kliznih vrata i sastoji se od grupa:

The system is used for making sliding/lift-sliding doors and consists of groups:

- Termo 120:
 - dvokrilna vrata.....(klizno/podizno klizno)
 - trokrilna vrata.....(klizno/podizno klizno)
 - četverokrilna vrata..(klizno/podizno klizno)
- Termo 120:
 - double lite doors.....(sliding/lift and sliding)
 - three lite doors.....(sliding/lift and sliding)
 - four lite doors.....(sliding/lift and sliding)
- Termo 120 plus:
 - jedno krilo klizno / podizno klizno+fiksno
 - dva srednja krila klizna / podizno klizna+bokovi fiksni
 - srednje krilo klizno / podizno klizno+ bokovi fiksni
 - krila na bokovima klizna / podizno klizna+ sredina fiksna
- Termo 120 plus:
 - one wing sliding / lifting sliding+fixed field
 - two middle wings sliding / lifting and sliding + sides fixed field
 - middle sash sliding / liftable sliding + sides fixed field
 - wings on the sides sliding / lifting and sliding + center fixed field

Profili su izvedeni s prekinutim toplinskim mostom:

- osnovne ugradbene dubine rama:

- dvije staze 126 mm	Termo 120
- tri staze 196.5 mm	Termo 120
- 126 mm	Termo 120 plus

Profiles are made with thermal break:

- basic mounting depth for frame:

- dvije staze 126 mm	Termo 120
- tri staze 196.5 mm	Termo 120
- 126 mm	Termo 120 plus

Prekid toplinskog mosta postiže se poliamidnim trakama (20 i 28 mm za ram i 20 i 26 mm za krilo)

Radi poboljšanja toplinskih karakteristika (smanjenja toplinske provodljivosti) u komore profila se ugrađuju trake od ekstrudiranog polistirena (XPS-a).

U kombinaciji s troslojnim staklom i odgovarajućim distancerom stakla sistem može postići ukupni koeficijent prolaska topline $U_d \geq 1.4$ [W/m²K].

Staklo je u krilu učvršćeno unutarnjim letvicama te zabrtvljeno EPDM brtvama s obje strane.

Okov je sistemski (klizni/podizno-klizni) različitih proizvođača.

Thermal brake is achieved with polyamide tapes (20 and 28 mm for frame and 20 and 26 mm for sash)

For improved thermal characteristics (reduction of thermal conductivity) polyester insulation tapes (XPS) are embedded into profile chambers.

In combination with three pane glass and adequate spacer system can reach total thermal transmittance coefficient of $U_d \geq 1.4$ [W/m²K].

Glass in sash is fixed with inner profile and sealed with EPDM gaskets on both side.

Hardware is systemic(sliding/lift and sliding)from different manufacturers.

Karakteristike sistema:System characteristics:

-materijal	EN AW-6060	-material	EN AW-6060
-masa krila	120-330 kg	-sash weight	120-330 kg
-debljina stakla	do 44 mm	-glass thickness	up to 44 mm
-materijal za brtvljenje (EPDM)	DIN 7863	-sealing material (EPDM)	DIN 7863
-proračun U_d koeficijenta	DIN EN ISO 10077-2	-calculation of U_d coefficient	DIN EN ISO 10077-2
-površinska obrada	DIN 17611	-surface treatment	DIN 17611
-kontrola kvalitete	DIN EN ISO 2041	-quality control	DIN EN ISO 2041

Ispitivanja i certifikati

Testing and certificates

ISPITIVANJA I CERTIFIKATI U TERMO 120 TESTING AND CERTIFICATES IN TERMO 120

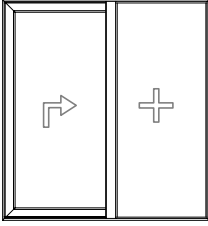
<p>Vrsta ispitivanja Type testing</p>	
<p>Zrakopropusnost Air permeability (EN12207)</p>	<p>Class 4</p>
<p>Vodonepropusnost Watertightness (EN 12208)</p>	<p>Class E900</p>
<p>Otpornost na vjetar Resistance to wind (EN 12210)</p>	<p>Class C4/B4</p>
<p>Buka Rw Noise Rw (EN ISO 717-1)</p>	<p>33 dB</p>
<p>Protuprovalnost Protection against burglary (EN 1627)</p>	<p>RC2</p>

* Termo 120 plus (niski prag)

* Termo 120 plus (low threshold)

Vrijednosti momenta inercije
Moment of inertia values

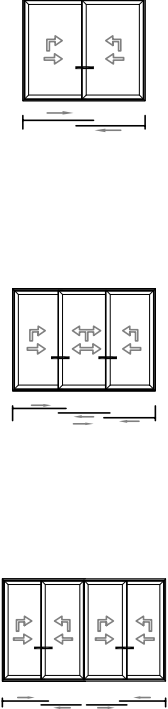
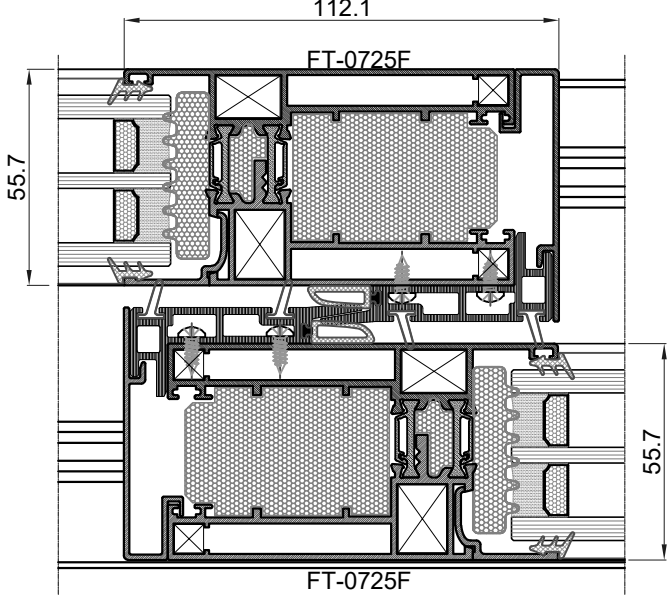
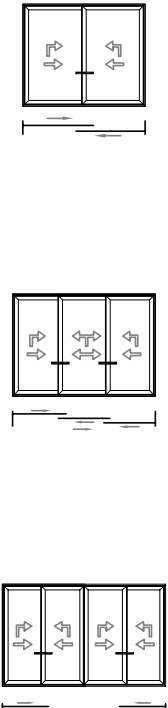
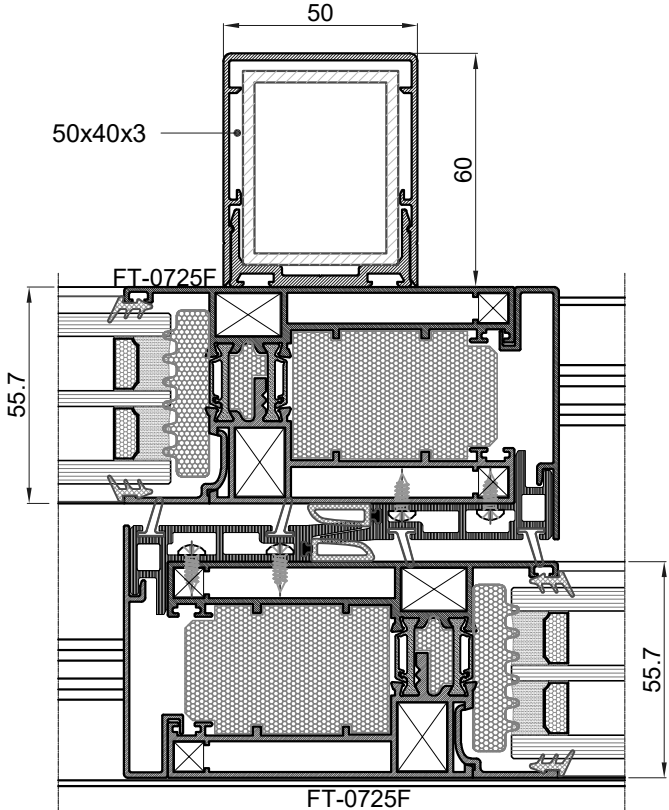
Tip otvaranja Opening type	Izgled View	Profili Profiles	I_x (cm ⁴)
	<p>M 1:1</p> 	<p>FT-0725F i FT-0725F</p>	<p>48.8</p>
	<p>M 1:1</p> 	<p>FT-0725F i FT-0725F + čelični profil 50x40x3</p>	<p>238</p>

Vrijednosti momenta inercije
Moment of inertia values

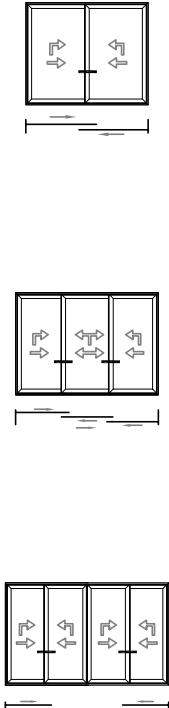
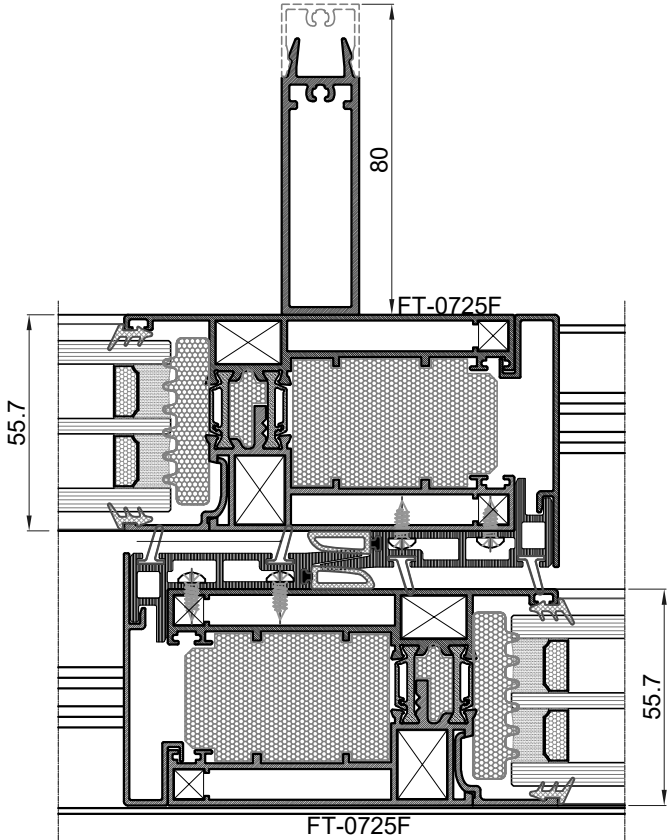
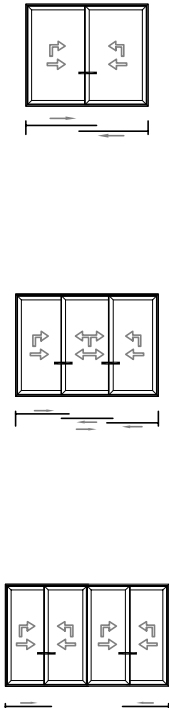
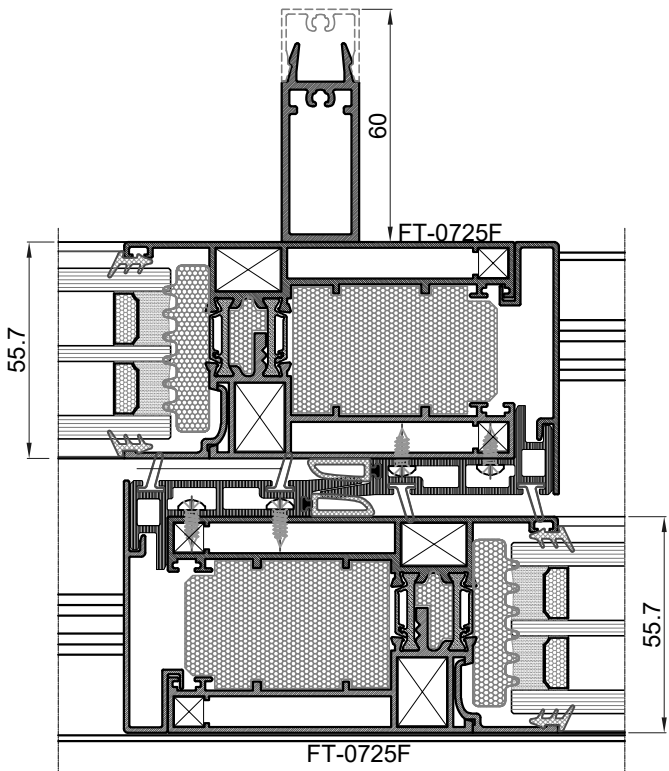
Tip otvaranja Opening type	Izgled View	Profili Profiles	I_x (cm ⁴)
	<p>M 1:1</p> 	<p>FT-0725F i FT-0725F + NP-4183</p>	<p>143.9</p>
	<p>M 1:1</p> 	<p>FT-0725F i FT-0725F + F-1634</p>	<p>99.3</p>

Vrijednosti momenta inercije
Moment of inertia values

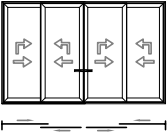
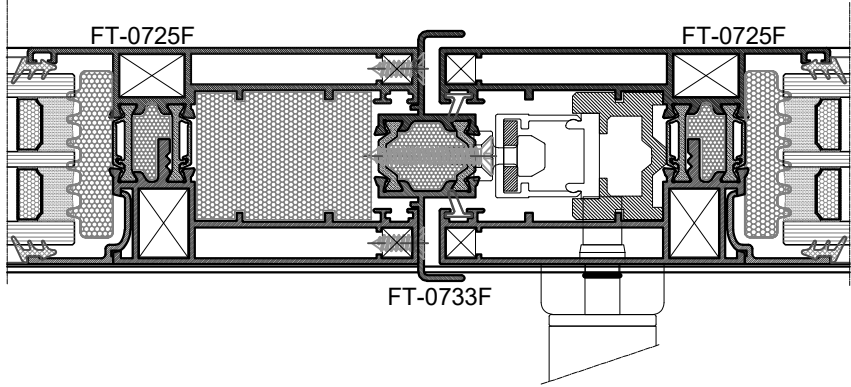
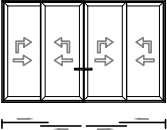
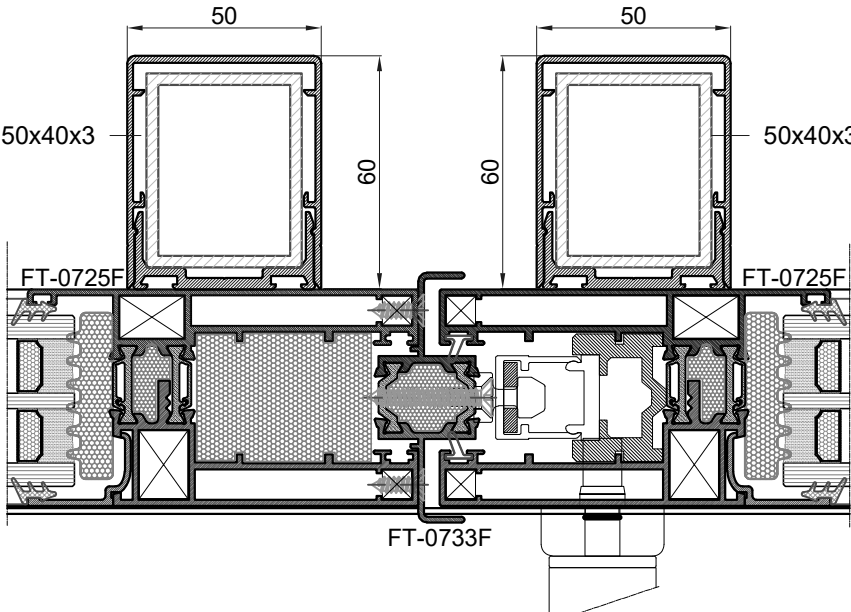
Tip otvaranja Opening type	Izgled View	Profili Profiles	I_x (cm ⁴)
	<p>M 1:1</p> 	<p>FT-0725F i FT-0725F + FT-0733F</p>	<p>54.5</p>
	<p>M 1:1</p> 	<p>FT-0725F + čelični profil 50x40x3 i FT-0725F + FT-0733F + čelični profil 50x40x3</p>	<p>461,1</p>

Vrijednosti momenta inercije
Moment of inertia values

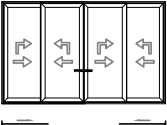
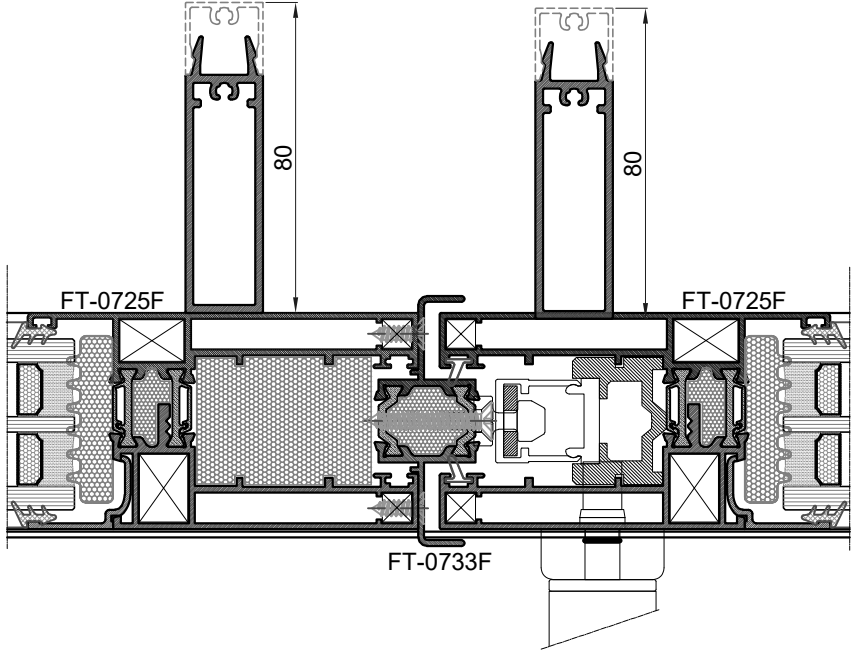
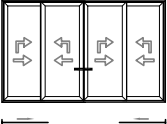
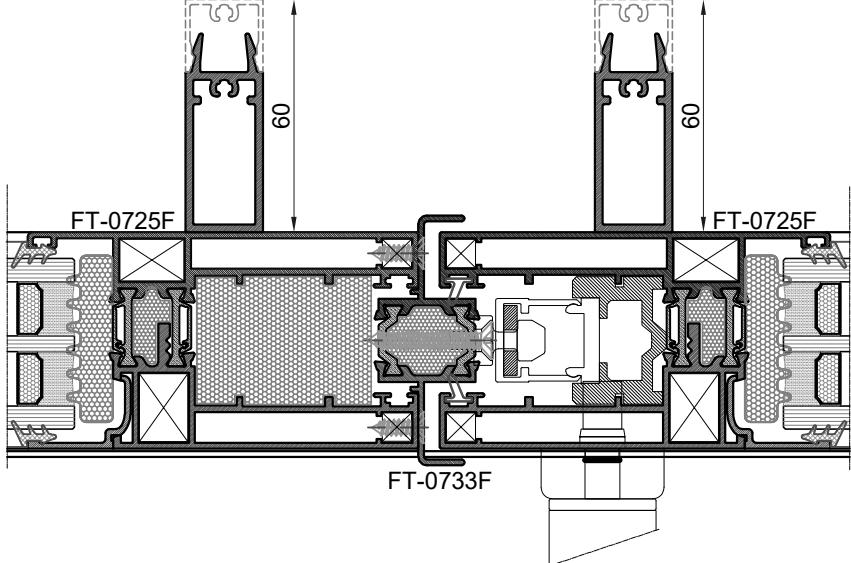
Tip otvaranja Opening type	Izgled View	Profili Profiles	I_x (cm ⁴)
	<p>M 1:1</p> 	<p>FT-0725F + NP-4183 i FT-0725F + FT-0733F + NP-4183</p>	<p>253.1</p>
	<p>M 1:1</p> 	<p>FT-0725F + F-1634 i FT-0725F + FT-0733F + F-1634</p>	<p>159.8</p>

Vrijednosti momenta inercije
Moment of inertia values

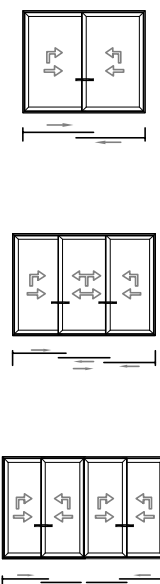
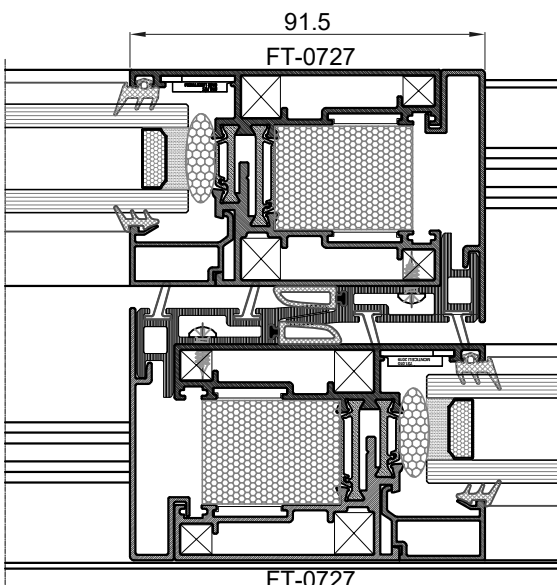
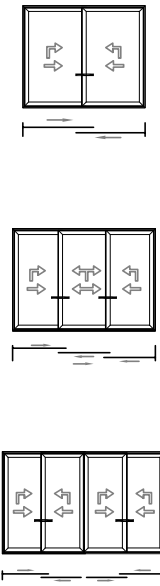
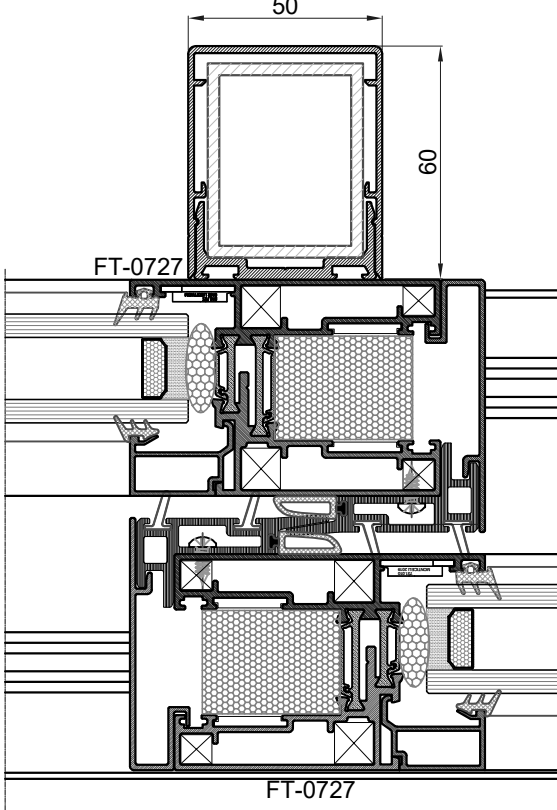
Tip otvaranja Opening type	Izgled View	Profili Profiles	I_x (cm ⁴)
	<p>M 1:1</p> 	<p>FT-0727 i FT-0727</p>	<p>36</p>
	<p>M 1:1</p> 	<p>FT-0727 i FT-0727 + čelični profil 50x40x3</p>	<p>203.4</p>

Vrijednosti momenta inercije
Moment of inertia values

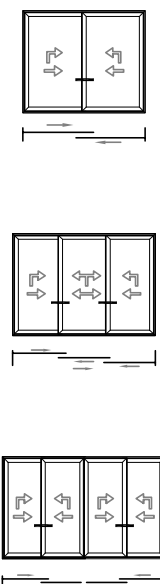
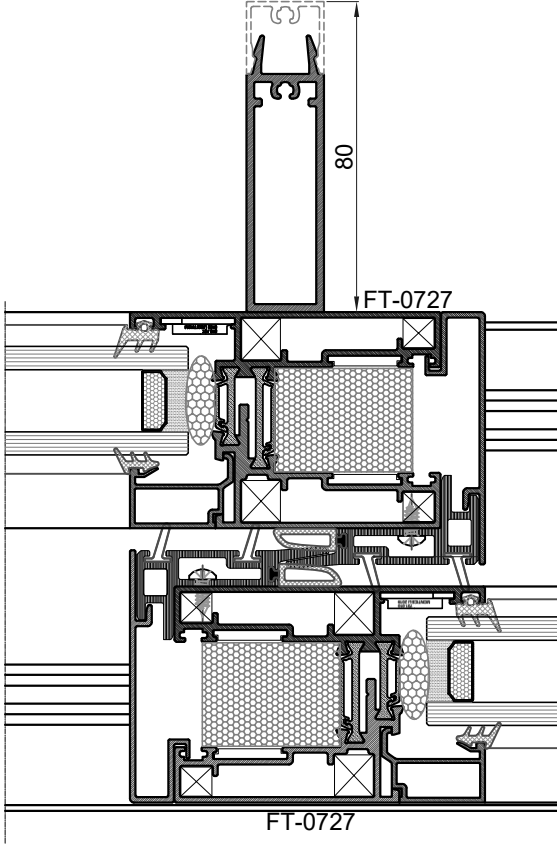
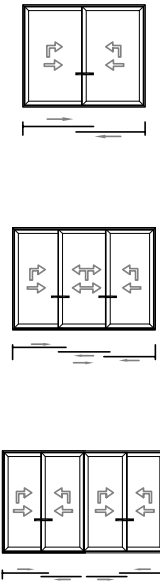
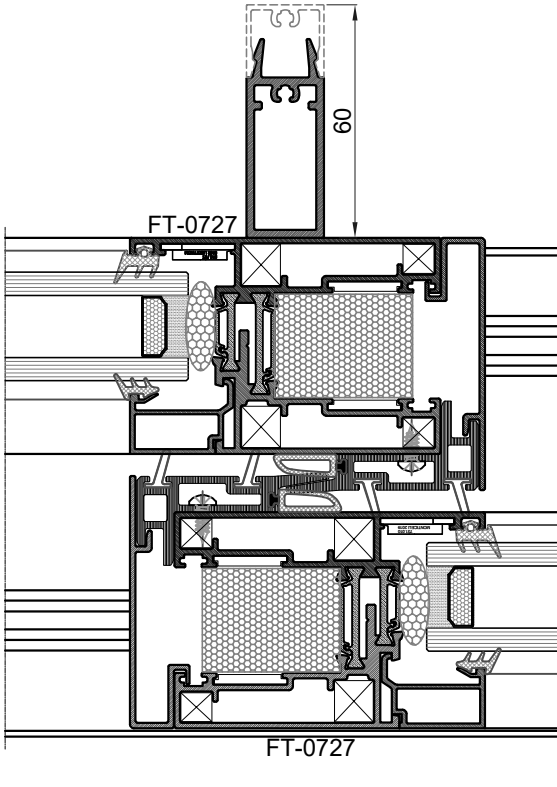
Tip otvaranja Opening type	Izgled View	Profili Profiles	I_x (cm ⁴)
<p>M 1:1</p> 	<p>M 1:1</p> 	<p>FT-0727 i FT-0727 + NP-4183</p>	<p>123.8</p>
<p>M 1:1</p> 	<p>M 1:1</p> 	<p>FT-0727 i FT-0727 + F-1634</p>	<p>83</p>

Vrijednosti momenta inercije
Moment of inertia values

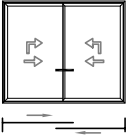
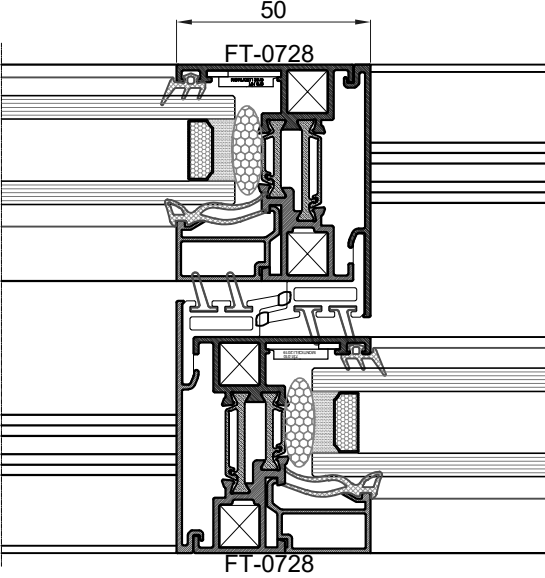
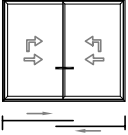
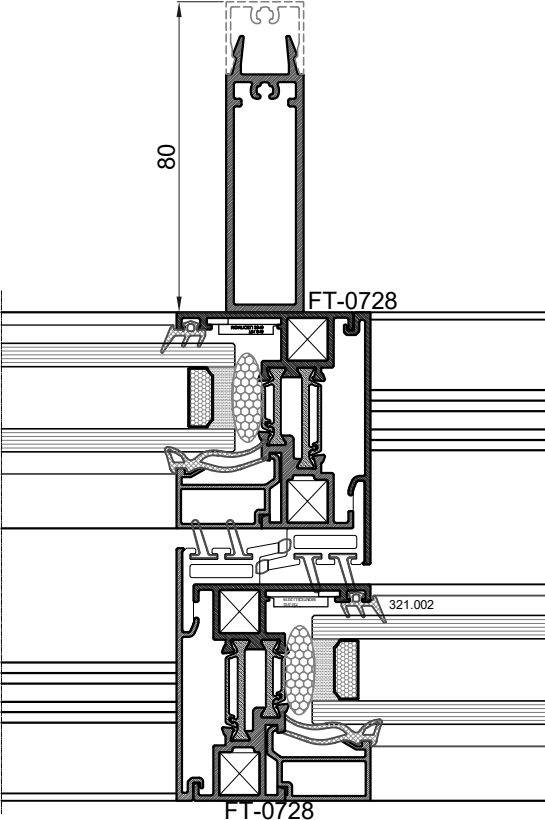
Tip otvaranja Opening type	Izgled View	Profili Profiles	I_x (cm ⁴)
	<p>M 1:1</p> 	<p>FT-0728 i FT-0728</p>	<p>20</p>
	<p>M 1:1</p> 	<p>FT-0728 i FT-0728 + NP-4183</p>	<p>88.9</p>

Vrijednosti momenta inercije
Moment of inertia values

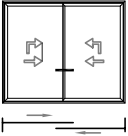
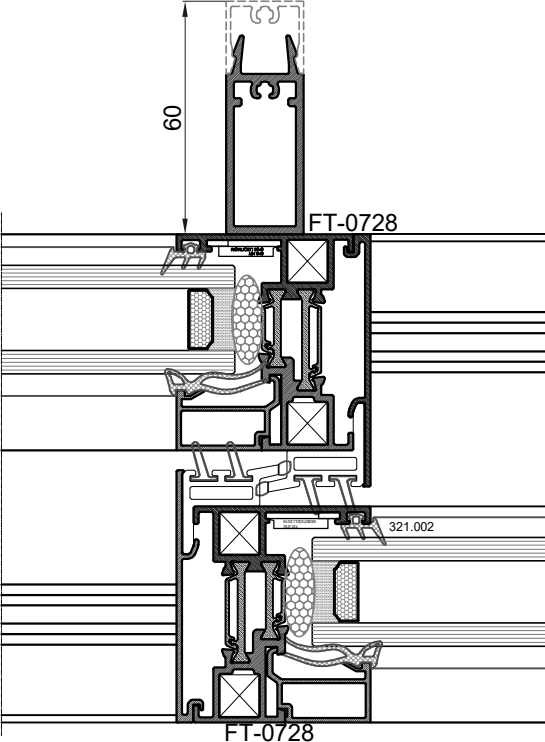
Tip otvaranja Opening type	Izgled View	Profili Profiles	I_x (cm ⁴)
	<p>M 1:1</p> 	<p>FT-0728 i FT-0728 + F-1634</p>	<p>56.9</p>

Vrijednosti momenta inercije
Moment of inertia values

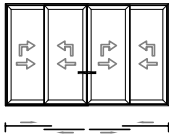
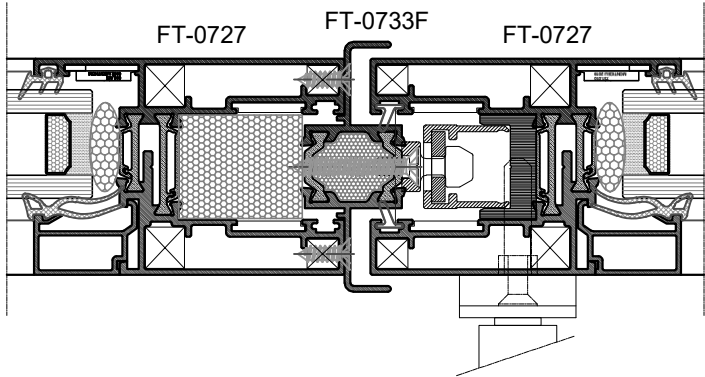
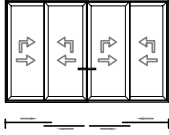
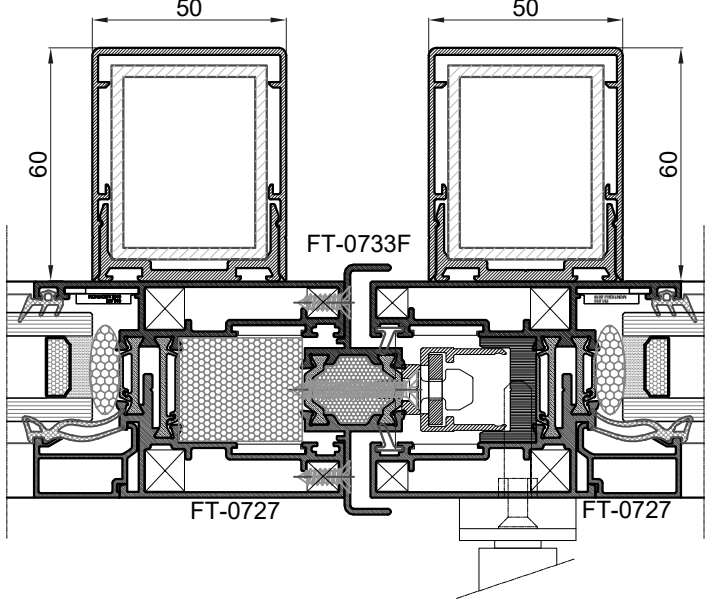
Tip otvaranja Opening type	Izgled View	Profili Profiles	I_x (cm ⁴)
	<p>M 1:1</p> 	<p>FT-0727 + FT-0733F i FT-0727</p>	<p>41.8</p>
	<p>M 1:1</p> 	<p>FT-0727 + FT-0733F + čelični profil 50x40x3 i FT-0727 + čelični profil 50x40x3</p>	<p>409.4</p>

Vrijednosti momenta inercije
Moment of inertia values

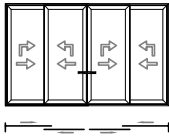
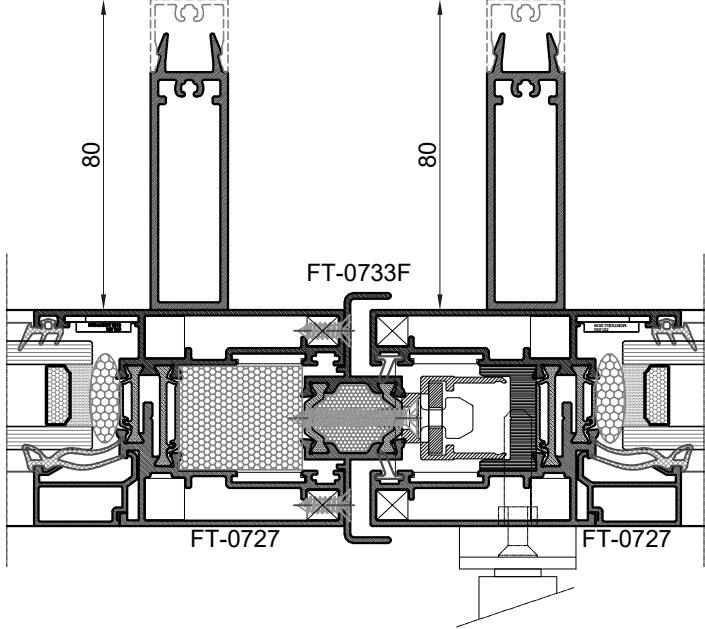
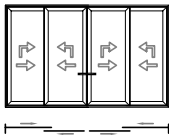
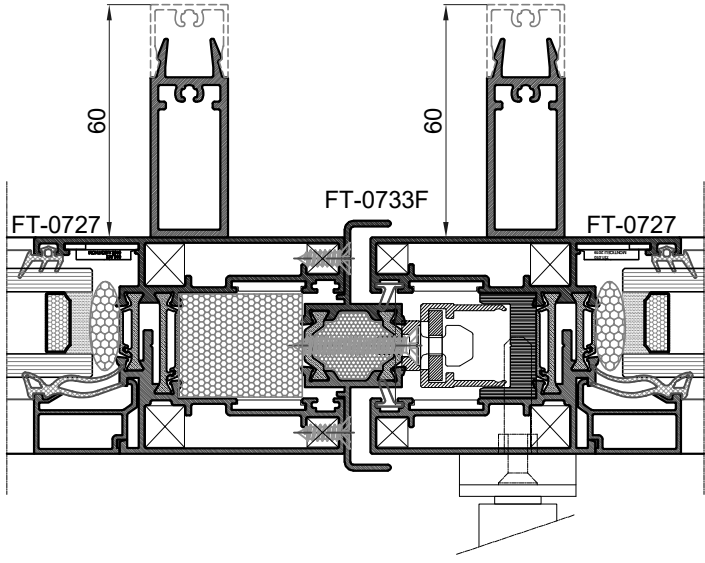
Tip otvaranja Opening type	Izgled View	Profili Profiles	I_x (cm ⁴)
	<p>M 1:1</p> 	<p>FT-0727 + FT-0733F + NP-4183 i FT-0727 + NP-4183</p>	<p>228.2</p>
	<p>M 1:1</p> 	<p>FT-0727 + FT-0733F + F-1634 i FT-0727 + F-1634</p>	<p>141.3</p>

Vrijednosti momenta inercije
Moment of inertia values

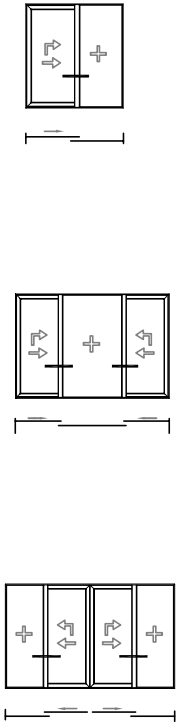
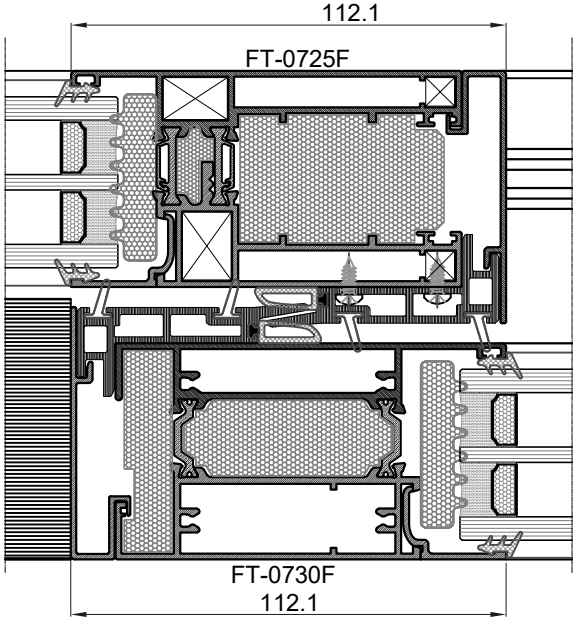
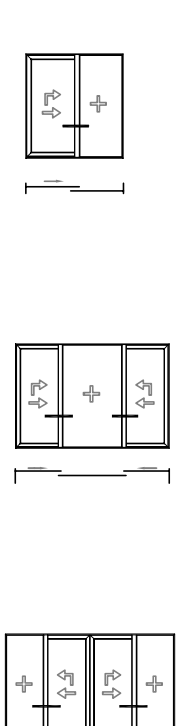
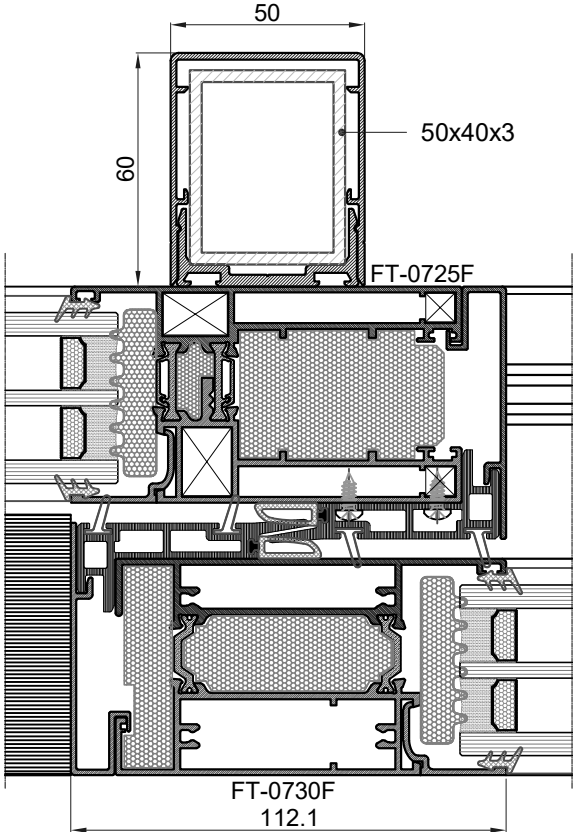
Tip otvaranja Opening type	Izgled View	Profili Profiles	I_x (cm ⁴)
	<p>M 1:1</p> 	<p>FT-0725F i FT-0730F</p>	<p>47</p>
	<p>M 1:1</p> 	<p>FT-0725F + čelični profil 50x40x3 i FT-0730F</p>	<p>236.2</p>

Vrijednosti momenta inercije
Moment of inertia values

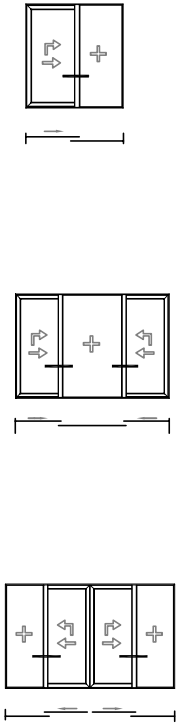
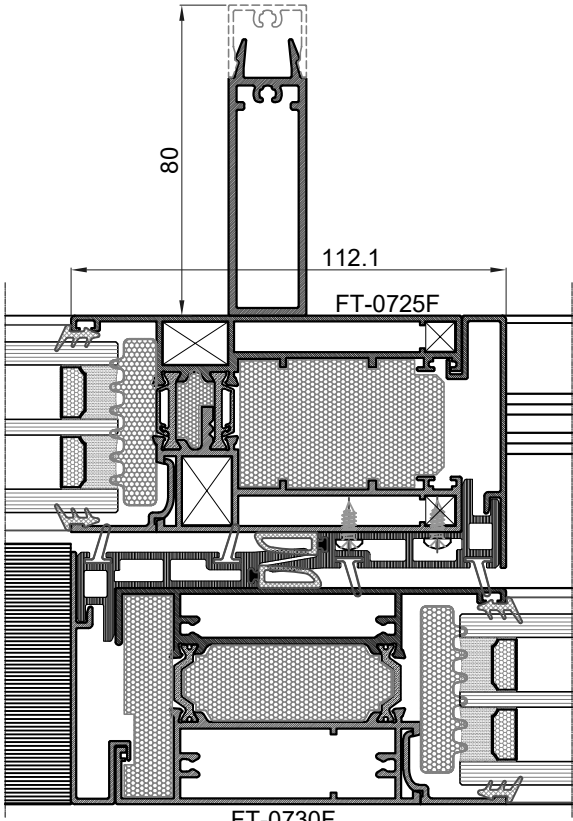
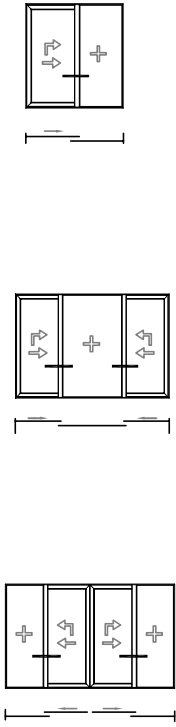
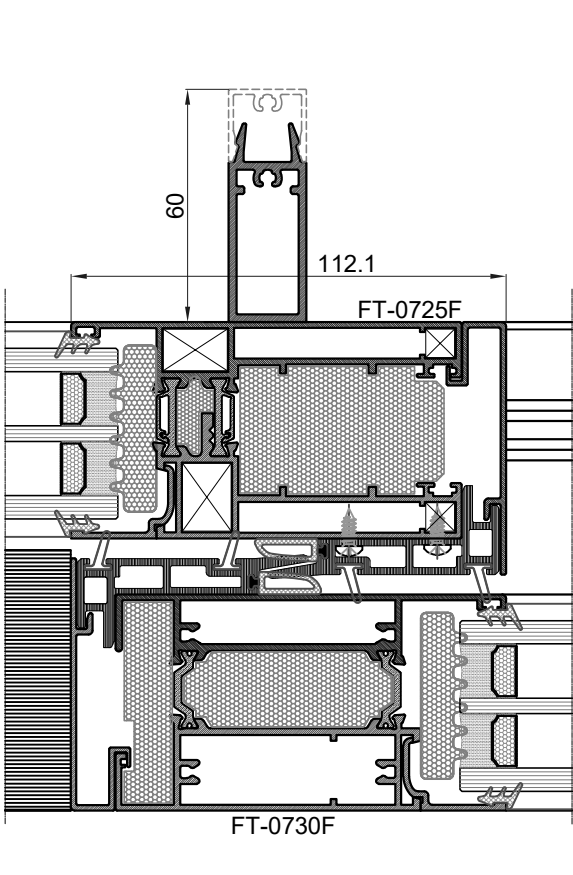
Tip otvaranja Opening type	Izgled View	Profili Profiles	I_x (cm ⁴)
	<p>M 1:1</p> 	<p>FT-0725F + NP-4183 i FT-0730F</p>	<p>142.1</p>
	<p>M 1:1</p> 	<p>FT-0725F + F-1634 i FT-0730F</p>	<p>97.5</p>

Vrijednosti momenta inercije
Moment of inertia values

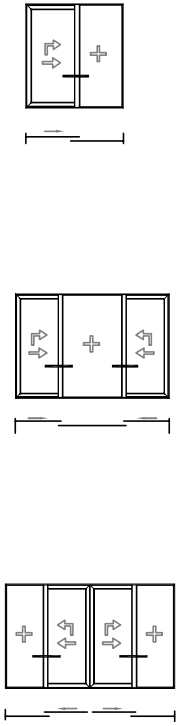
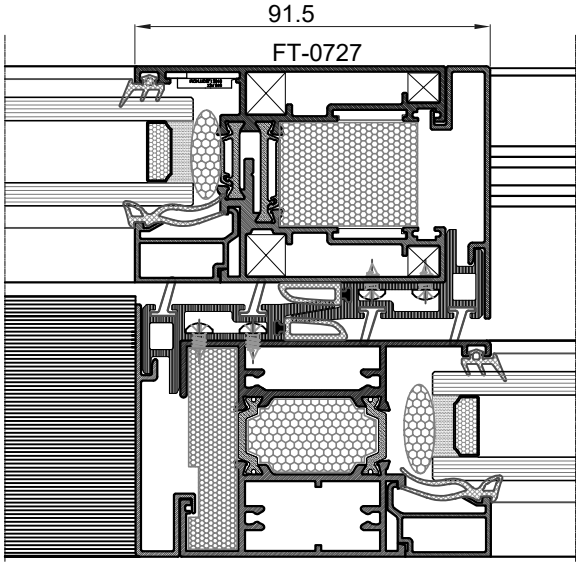
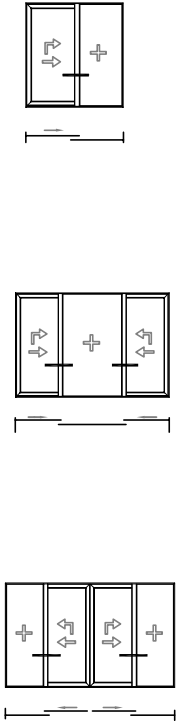
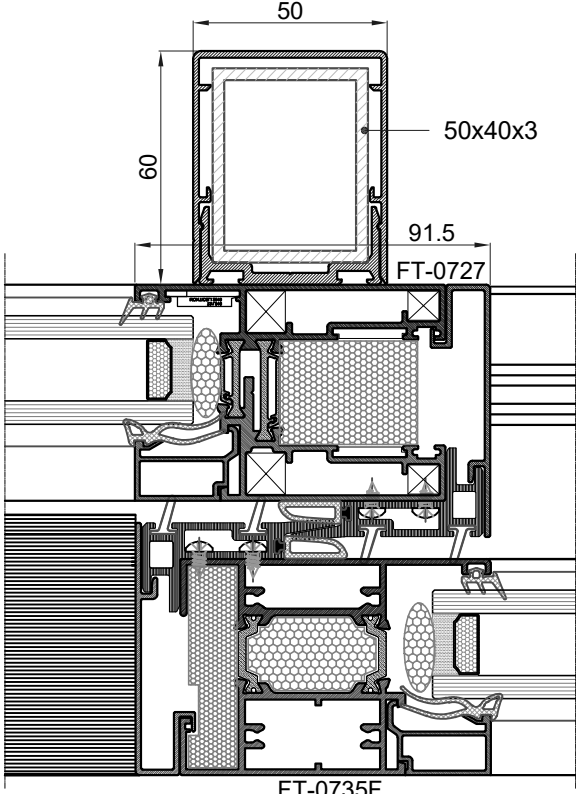
Tip otvaranja Opening type	Izgled View	Profili Profiles	I_x (cm ⁴)
	<p>M 1:1</p> 	<p>FT-0727 i FT-0735F</p>	<p>36.6</p>
	<p>M 1:1</p> 	<p>FT-0727 + čelični profil 50x40x3 i FT-0735F</p>	<p>204</p>

Vrijednosti momenta inercije
Moment of inertia values

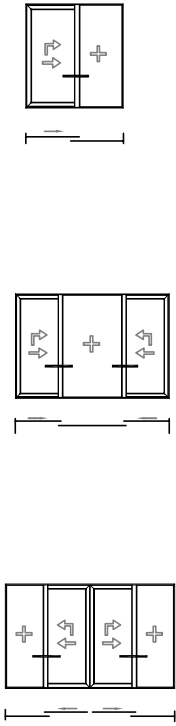
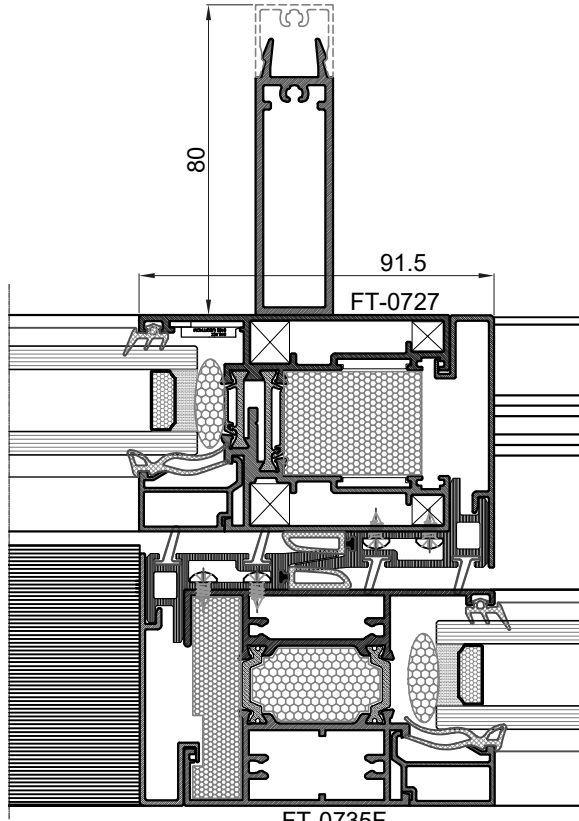
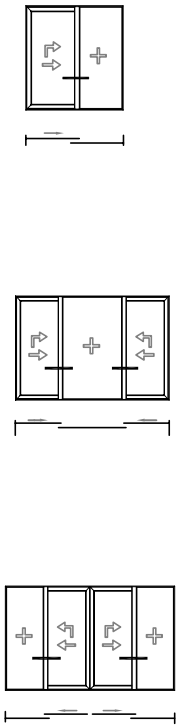
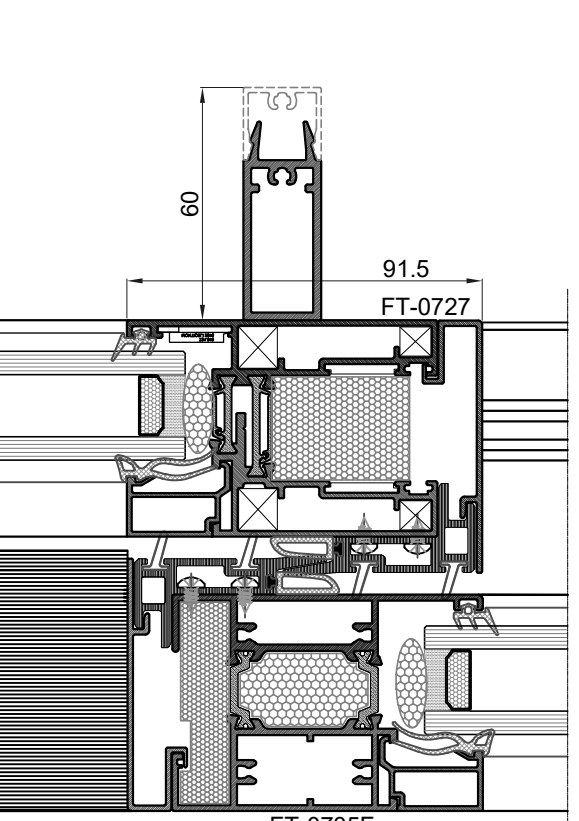
Tip otvaranja Opening type	Izgled View	Profili Profiles	I_x (cm ⁴)
	<p>M 1:1</p> 	<p>FT-0727 + NP-4183 i FT-0735F</p>	<p>124.4</p>
	<p>M 1:1</p> 	<p>FT-0727 + F-1634 i FT-0735F</p>	<p>83.6</p>

Vrijednosti momenta inercije
Moment of inertia values

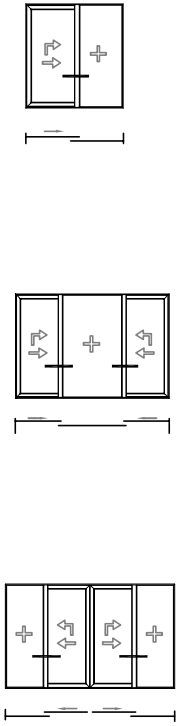
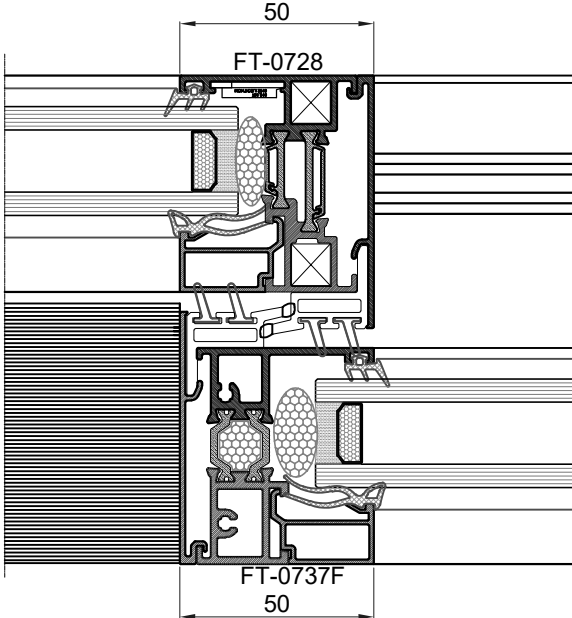
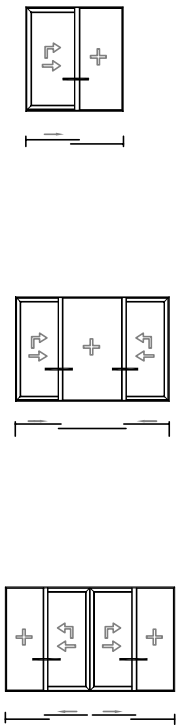
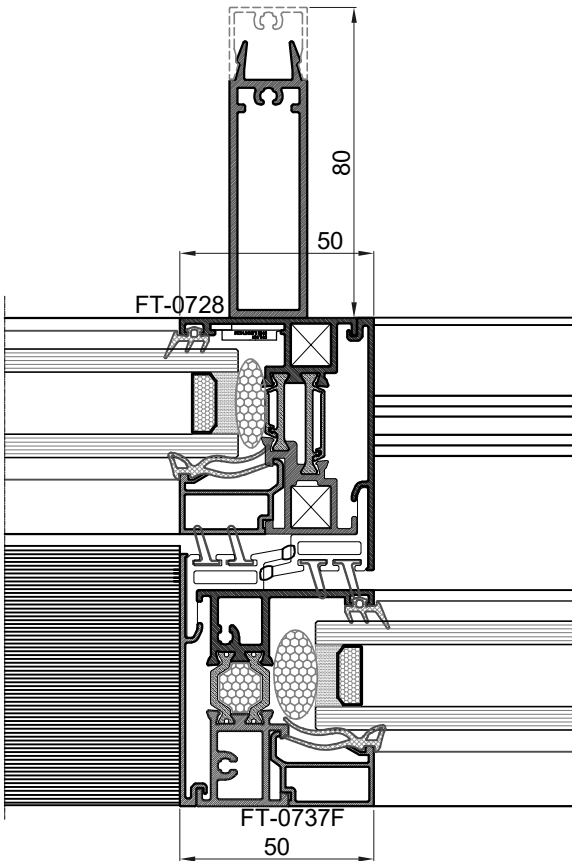
Tip otvaranja Opening type	Izgled View	Profili Profiles	I_x (cm ⁴)
<p>M 1:1</p> 	<p>M 1:1</p> 	<p>FT-0728 i FT-0737F</p>	<p>21</p>
<p>M 1:1</p> 	<p>M 1:1</p> 	<p>FT-0728 + NP-4183 i FT-0737F</p>	<p>89.9</p>

Vrijednosti momenta inercije
Moment of inertia values

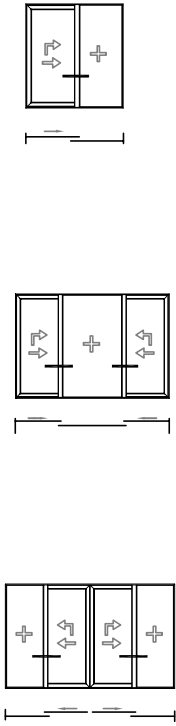
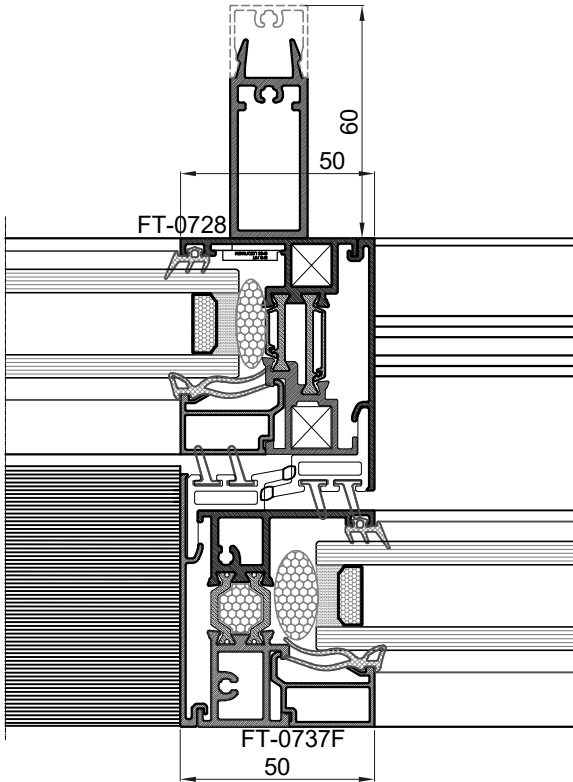
Tip otvaranja Opening type	Izgled View	Profili Profiles	I_x (cm ⁴)
	<p>M 1:1</p> 	<p>FT-0728 + F-1634 i FT-0737F</p>	<p>57.9</p>

Profili Profiles

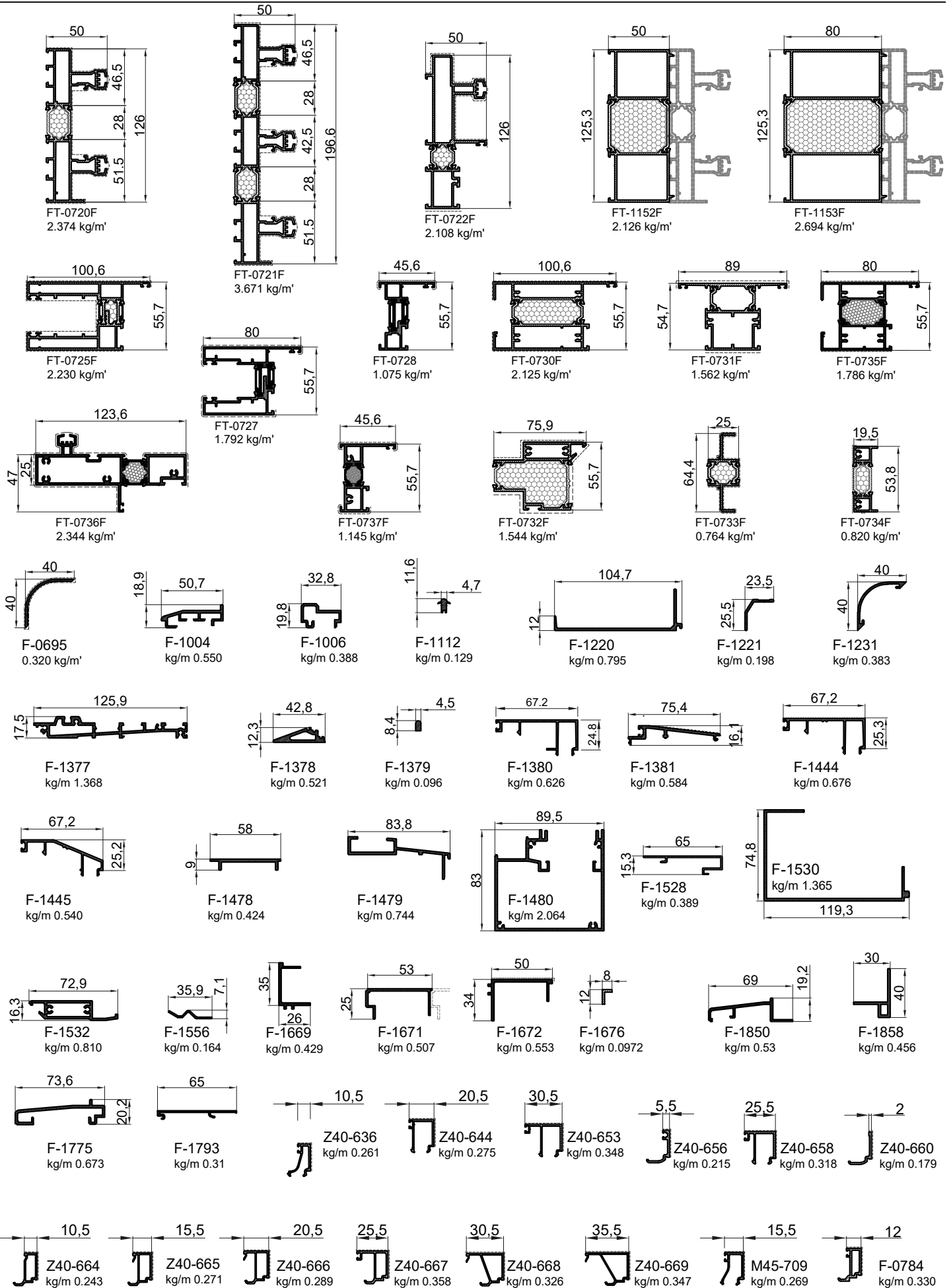

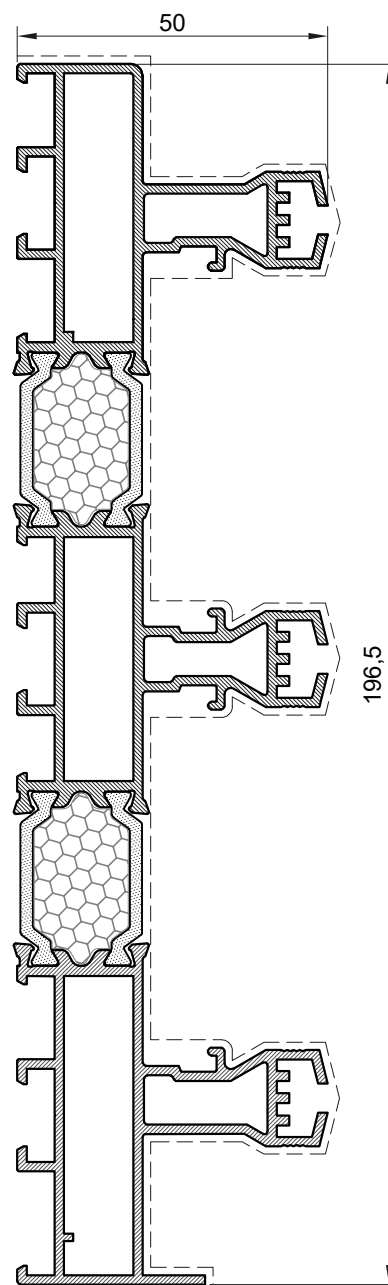
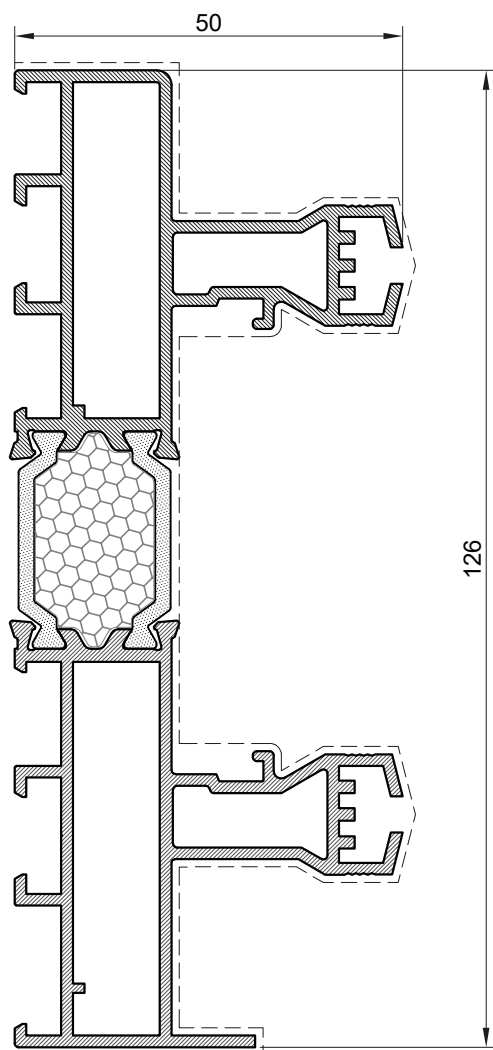

M 1:1.25

Profil rama Frame profile		
Art.broj Art.num.	Novi New	FT-0720F
	Stari Old	TI-928/929-A
Težina Weight	kg/m'	2.374
Opseg Perimeter	mm	653.527
Moment inercije Moments of inertia	I _x (cm ⁴)	90.85
	I _y (cm ⁴)	16.60
	W _x (cm ³)	19.30
	W _y (cm ³)	5.540
L	mm	6500

Profil rama Frame profile		
Art.broj Art.num.	Novi New	FT-0721F
	Stari Old	TI-928/29/30-A
Težina Weight	kg/m'	3.671
Opseg Perimeter	mm	975.03
Moment inercije Moments of inertia	I _x (cm ⁴)	341.96
	I _y (cm ⁴)	25.22
	W _x (cm ³)	44.23
	W _y (cm ³)	8.390
L	mm	6500

PROFIL BEZ XPS ISPUNE U NAZIVU NEMA NASTAVKA „F”
PROFILES WITHOUT XPS DO NOT HAVE ENDING "F"

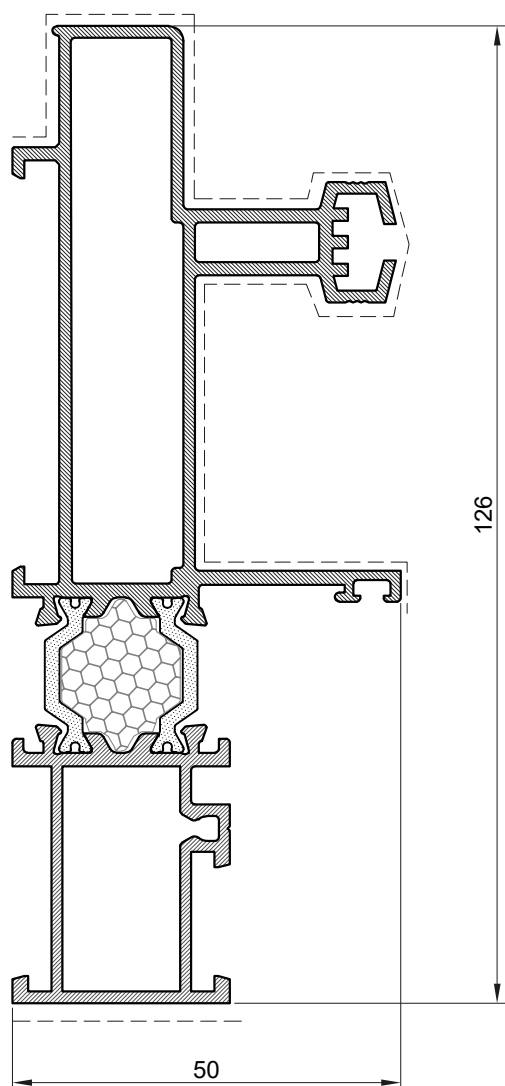

Ram /Termo 120 plus/ Frame /Termo 120 plus/		
Art. broj Art. num.	Novi New	FT-0722F
	Stari Old	TI-931/692
Težina Weight	kg/m'	2.108
Opseg Perimeter	mm	575.13
Moment inerције Moments of inertia	I _x (cm ⁴)	80.18
	I _y (cm ⁴)	12.18
	W _x (cm ³)	15.75
	W _y (cm ³)	4.04
L	mm	6500

PROFIL BEZ XPS ISPUNE U NAZIVU NEMA NASTAVKA „F”
PROFILES WITHOUT XPS DO NOT HAVE ENDING "F"

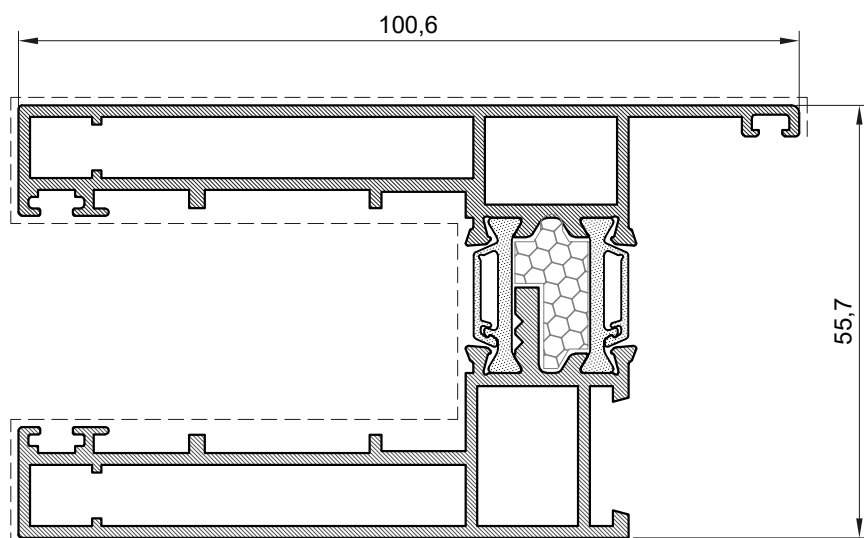

Kriilo Sash		
Art.broj Art.num.	Novi New	FT-0725F
	Stari Old	TI-917/918-A
Težina Weight	kg/m'	2.230
Opseg Perimeter	mm	525.049
Moment inercije Moments of inertia	Ix (cm ⁴)	24.28
	Iy (cm ⁴)	54.62
	Wx (cm ³)	11.28
	Wy (cm ³)	9.940
L	mm	6500

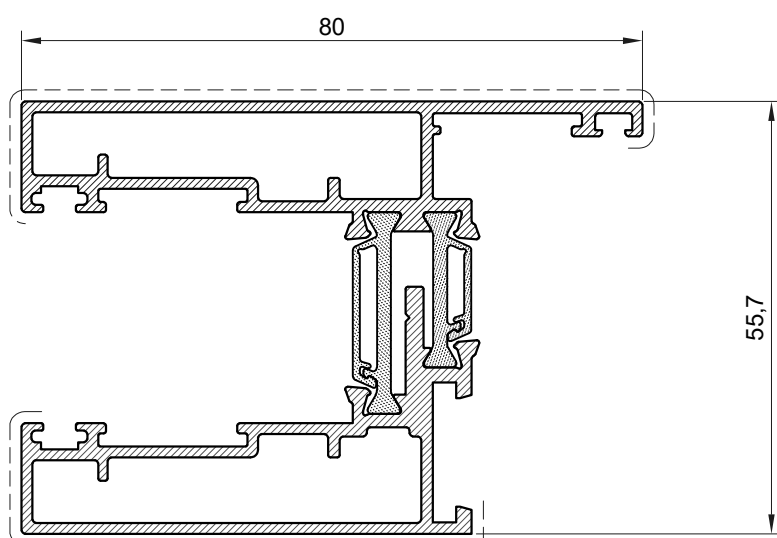

Kriilo Sash		
Art.broj Art.num.	Novi New	FT-0727
	Stari Old	TI-945/946
Težina Weight	kg/m'	1.792
Opseg Perimeter	mm	445
Moment inercije Moments of inertia	Ix (cm ⁴)	18.07
	Iy (cm ⁴)	26.18
	Wx (cm ³)	8.31
	Wy (cm ³)	5.85
L	mm	6500

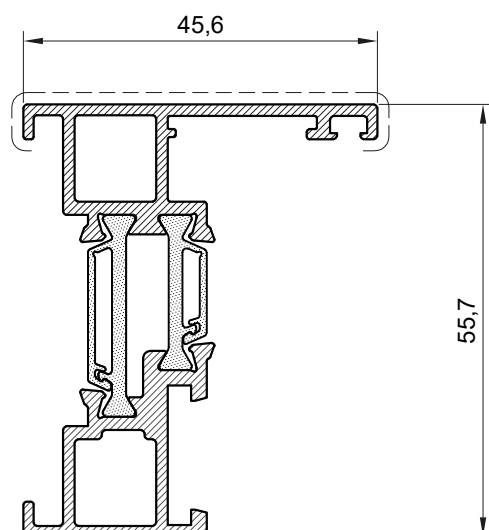

Kriilo Sash		
Art.broj Art.num.	Novi New	FT-0728
	Stari Old	TI-947/948
Težina Weight	kg/m'	1.075
Opseg Perimeter	mm	276
Moment inercije Moments of inertia	Ix (cm ⁴)	9.96
	Iy (cm ⁴)	3.38
	Wx (cm ³)	4.38
	Wy (cm ³)	1.17
L	mm	6500

PROFIL BEZ XPS ISPUNE U NAZIVU NEMA NASTAVKA „F”
PROFILES WITHOUT XPS DO NOT HAVE ENDING "F"

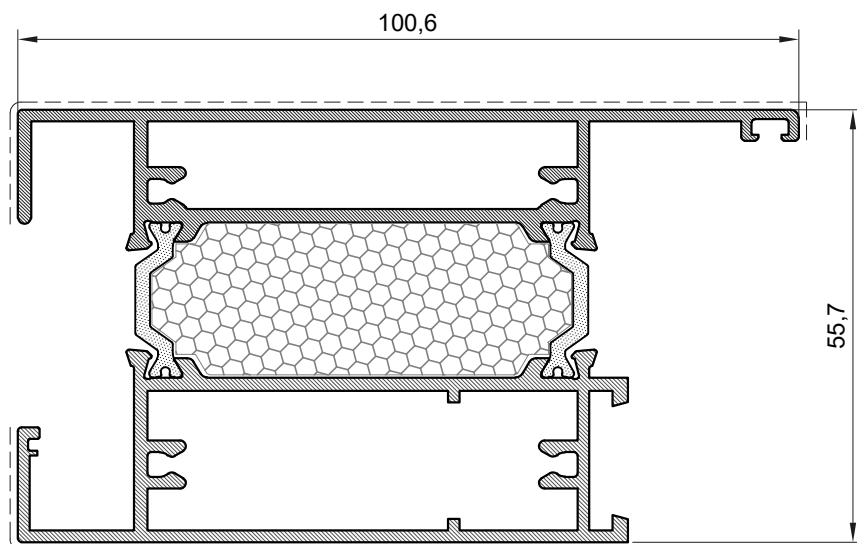

Prečka /T120 plus/ Mullion /T120 plus/		
Art.broj Art.num.	Novi New	FT-0730F
	Stari Old	TI-923/924-A
Težina Weight	kg/m'	2.125
Opseg Perimeter	mm	443.30
Moment inercije	I _x (cm ⁴)	22.61
	I _y (cm ⁴)	51.89
Moments of inertia	W _x (cm ³)	10.31
	W _y (cm ³)	9.02
L	mm	6500

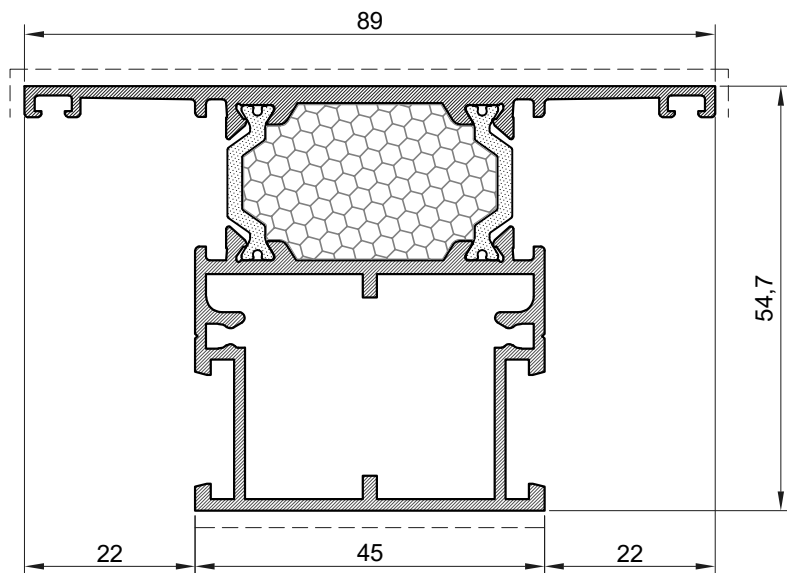

Prečka /T120 plus/ Mullion /T120 plus/		
Art.broj Art.num.	Novi New	FT-0731F
	Stari Old	FT-0105/D
Težina Weight	kg/m'	1.562
Opseg Perimeter	mm	378.42
Moment inercije	I _x (cm ⁴)	15.87
	I _y (cm ⁴)	20.51
Moments of inertia	W _x (cm ³)	6.25
	W _y (cm ³)	4.61
L	mm	6500

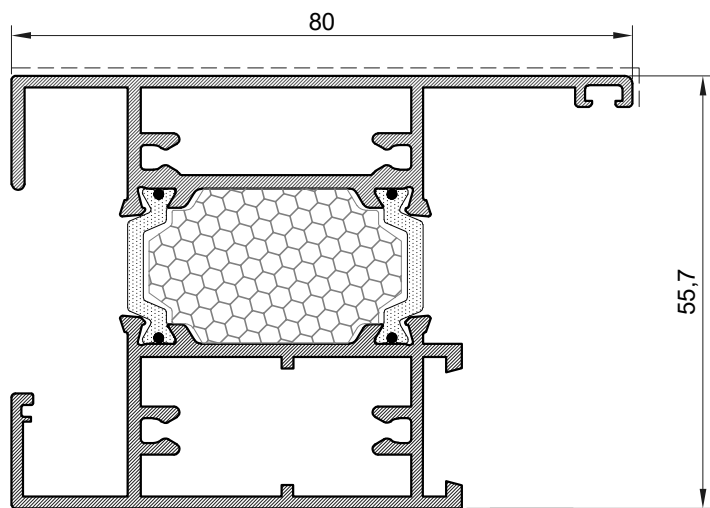

Prečka /T120 plus/ Mullion /T120 plus/		
Art.broj Art.num.	Novi New	FT-0735F
	Stari Old	T1-932/T1-933
Težina Weight	kg/m'	1.786
Opseg Perimeter	mm	398
Moment inercije	I _x (cm ⁴)	18.56
	I _y (cm ⁴)	23.46
Moments of inertia	W _x (cm ³)	8.49
	W _y (cm ³)	4.98
L	mm	6500

PROFIL BEZ XPS ISPUNE U NAZIVU NEMA NASTAVKA „F”
PROFILES WITHOUT XPS DO NOT HAVE ENDING "F"

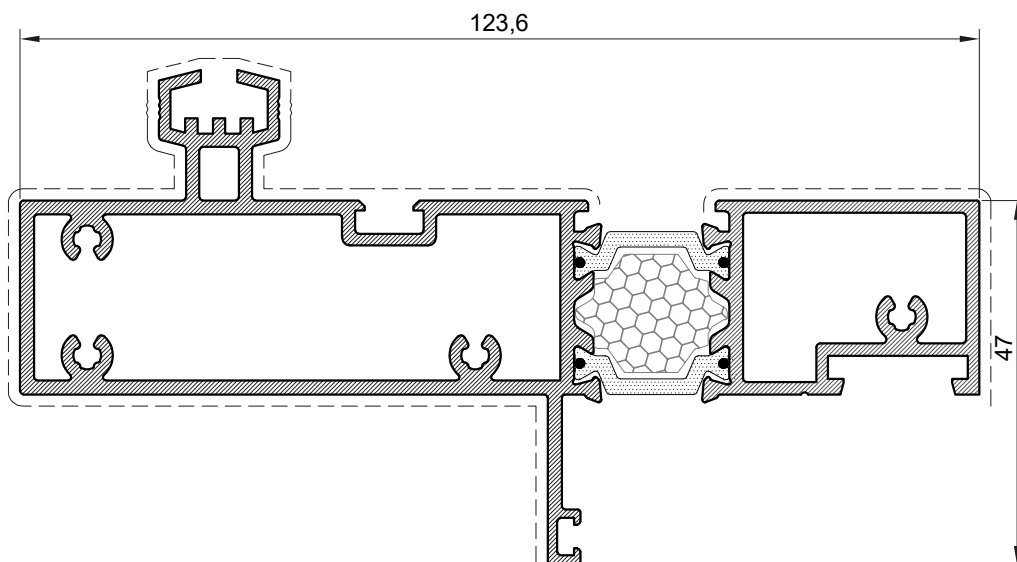

Prečka /T120 plus/ Mullion /T120 plus/		
Art.broj Art.num.	Novi New	FT-0736F
	Stari Old	T1-943/T1-944
Težina Weight	kg/m'	2.344
Opseg Perimeter	mm	482
Moment inerције Moments of inertia	I _x (cm ⁴)	13.22
	I _y (cm ⁴)	93.82
	W _x (cm ³)	3.75
	W _y (cm ³)	17.92
L	mm	6500

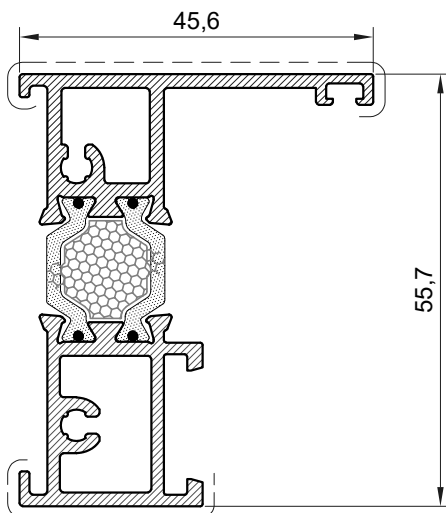

Prečka /T120 plus/ Mullion /T120 plus/		
Art.broj Art.num.	Novi New	FT-0737F
	Stari Old	T1-1700/ T1-1701
Težina Weight	kg/m'	1.145
Opseg Perimeter	mm	257
Moment inercije Moments of inertia	I _x (cm ⁴)	11.06
	I _y (cm ⁴)	3.74
	W _x (cm ³)	4.89
	W _y (cm ³)	1.19
L	mm	6500

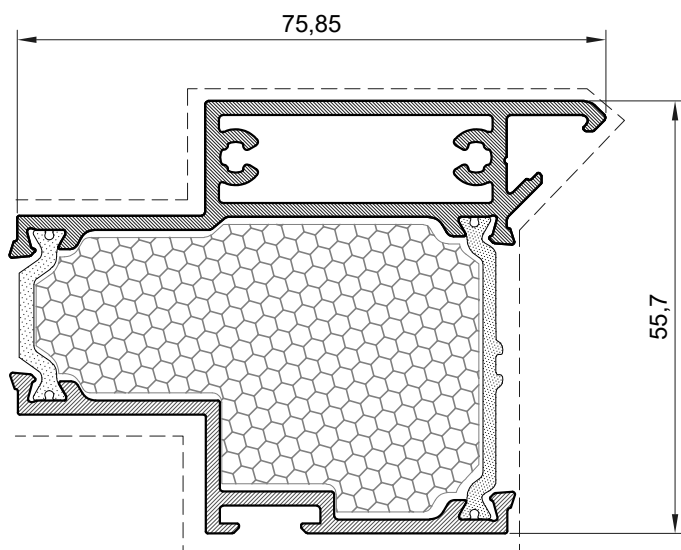

Umetak-spoj pod 90° Insert-joint under 90°		
Art.broj Art.num.	Novi New	FT-0732F
	Stari Old	TI-937/938
Težina Weight	kg/m'	1.544
Opseg Perimeter	mm	300.205
Moment inercije Moments of inertia	I _x (cm ⁴)	-
	I _y (cm ⁴)	-
	W _x (cm ³)	-
	W _y (cm ³)	-
L	mm	6500

PROFIL BEZ XPS ISPUNE U NAZIVU NEMA NASTAVKA „F“
PROFILES WITHOUT XPS DO NOT HAVE ENDING "F"

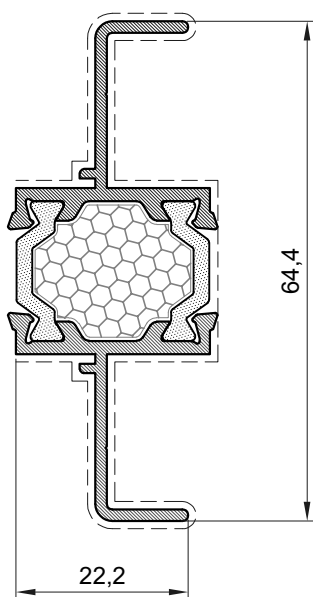

Spojnica /Termo 120/ Coupling /Termo 120/		
Art.broj Art.num.	Novi New	FT-0733F
	Stari Old	TI-913/2-A
Težina Weight	kg/m'	0.764
Opseg Perimeter	mm	230.00
Moment inercije Moments of inertia	I _x (cm ⁴)	5.65
	I _y (cm ⁴)	1.04
	W _x (cm ³)	2.26
	W _y (cm ³)	0.76
L	mm	6500

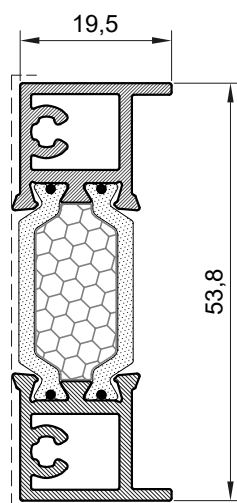

Umetak Insert		
Art.broj Art.num.	Novi New	FT-0734F
	Stari Old	TI-941/2-A
Težina Weight	kg/m'	0.820
Opseg Perimeter	mm	160.071
Moment inercije Moments of inertia	I _x (cm ⁴)	6.790
	I _y (cm ⁴)	0.720
	W _x (cm ³)	3.500
	W _y (cm ³)	0.600
L	mm	6500

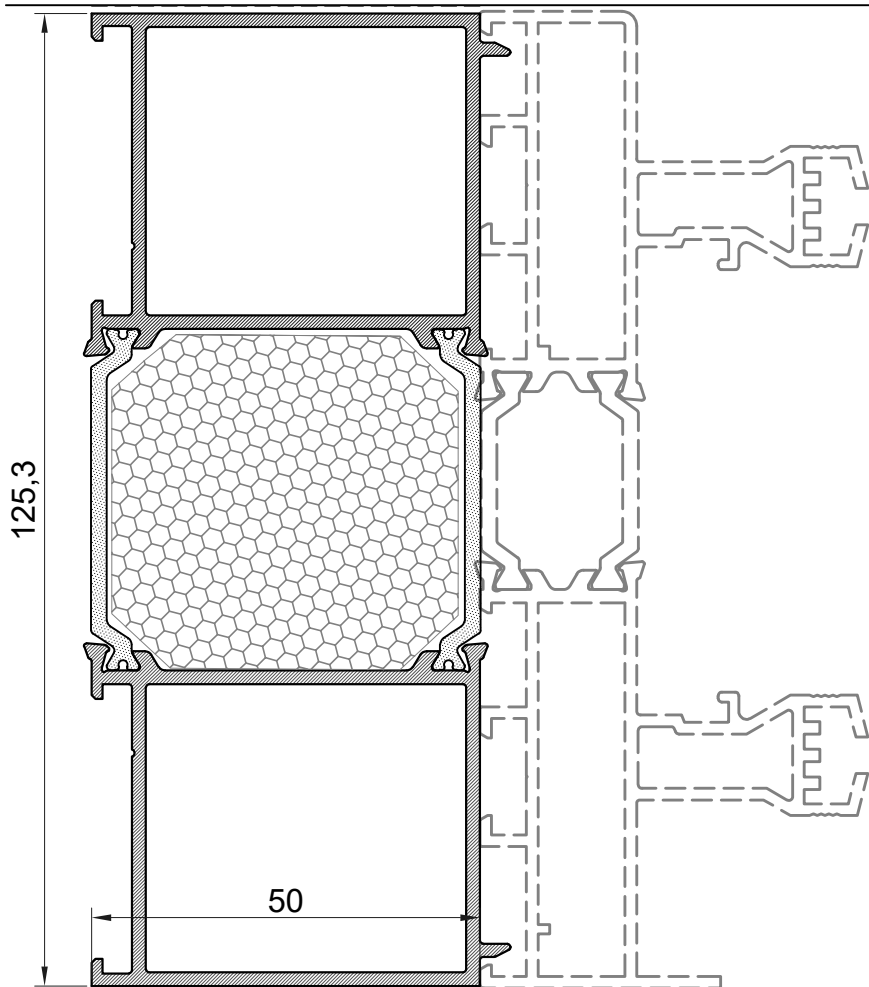

Proširenje rama FT-0720F
Extension frame FT-0720F

Art.broj Art.num.	FT-1152F	
Težina Weight	kg/m'	2.126
Opseg Perimeter	mm	403.05
Moment inercije	I _x (cm ⁴)	133.13
	I _y (cm ⁴)	23.24
Moments of inertia	W _x (cm ³)	21.25
	W _y (cm ³)	8.35
L	mm	6500

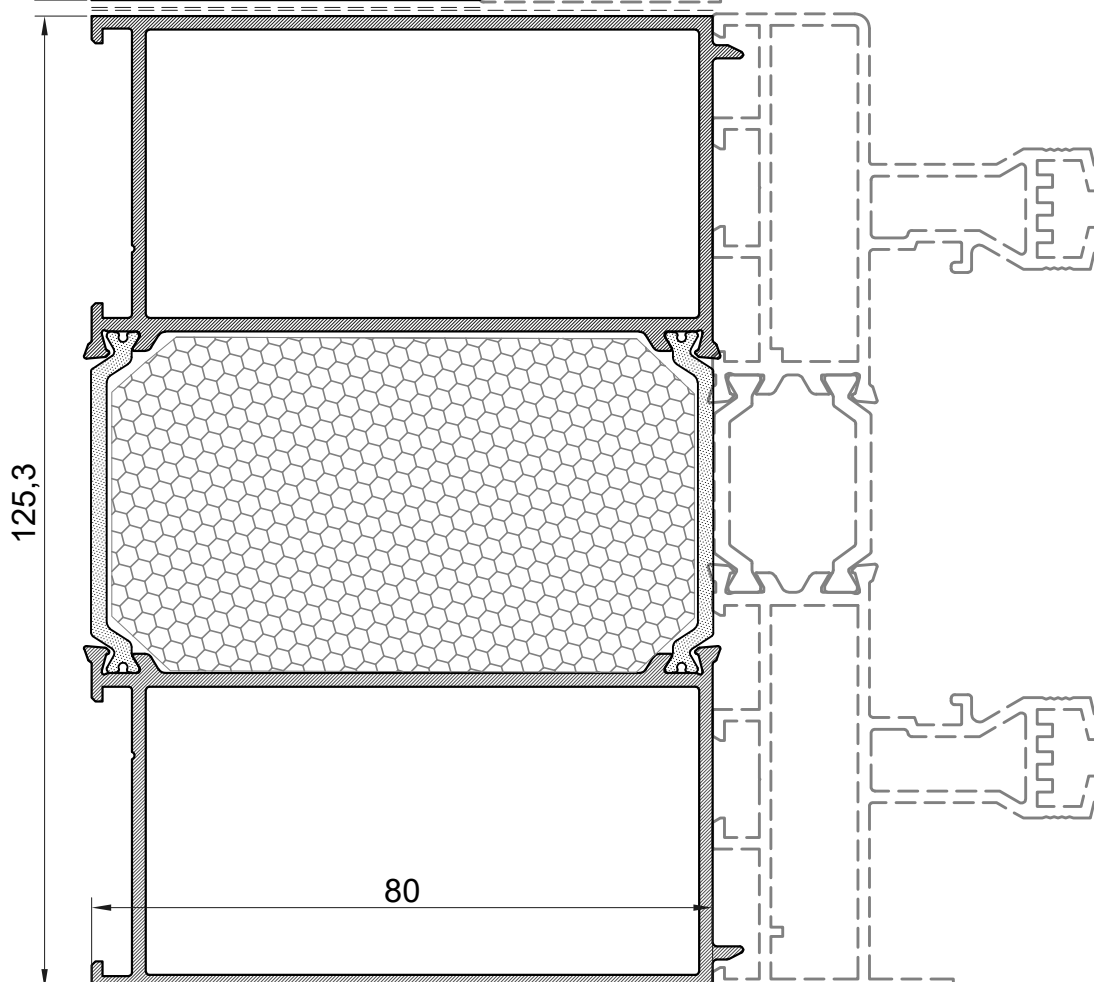

Proširenje rama FT-0720F
Extension frame FT-0720F

Art.broj Art.num.	FT-1153F	
Težina Weight	kg/m'	2.694
Opseg Perimeter	mm	436.05
Moment inercije	I _x (cm ⁴)	178.70
	I _y (cm ⁴)	75.01
Moments of inertia	W _x (cm ³)	28.53
	W _y (cm ³)	17.43
L	mm	6500

PROFIL BEZ XPS ISPUNE U NAZIVU NEMA NASTAVKA „F”

PROFILES WITHOUT XPS DO NOT HAVE ENDING "F"

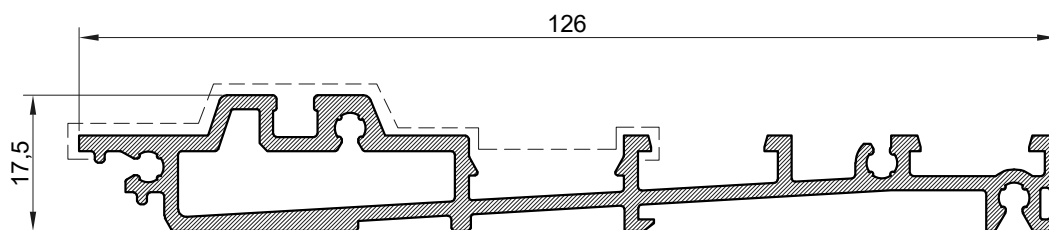

Ram-niski prag Frame-low threshold		
Art.broj Art.num.	F-1377	
Težina Weight	kg/m'	1.368
Opseg Perimeter	mm	422.82
Moment inerције Moments of inertia	I _x (cm ⁴)	1.0577
	I _y (cm ⁴)	70.8589
	W _x (cm ³)	1.0239
	W _y (cm ³)	10.3398
L	mm	6500

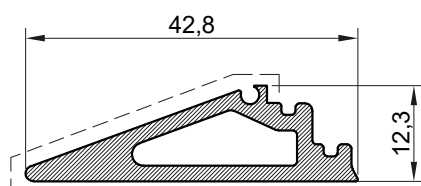

Al umetak-niski prag Al insert-low threshold		
Art.broj Art.num.	F-1378	
Težina Weight	kg/m'	0.521
Opseg Perimeter	mm	107.94
Moment inercije Moments of inertia	I _x (cm ⁴)	0.2114
	I _y (cm ⁴)	2.6509
	W _x (cm ³)	0.2520
	W _y (cm ³)	1.1698
L	mm	6500

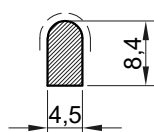

Al vodilica-niski prag Al guide-low threshold		
Art.broj Art.num.	F-1379	
Težina Weight	kg/m'	0.096
Opseg Perimeter	mm	23.77
Moment inercije Moments of inertia	I _x (cm ⁴)	-
	I _y (cm ⁴)	-
	W _x (cm ³)	-
	W _y (cm ³)	-
L	mm	6500

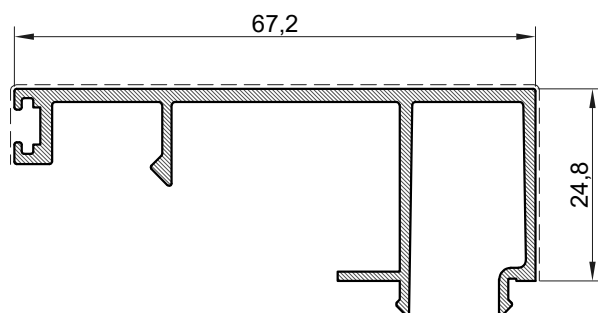

Al maska-niski prag Al mask-low threshold		
Art.broj Art.num.	F-1380	
Težina Weight	kg/m'	0.626
Opseg Perimeter	mm	303.22
Moment inercije	I _x (cm ⁴)	1.5802
	I _y (cm ⁴)	11.3486
Moments of inertia	W _x (cm ³)	0.7118
	W _y (cm ³)	2.9174
L	mm	6500

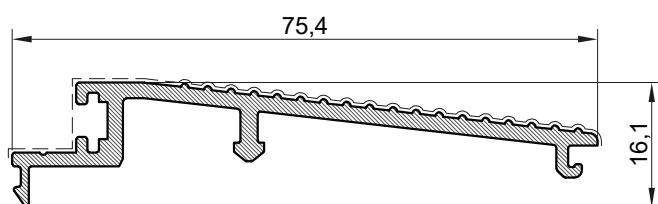

Al maska-niski prag Al maska-niski prag		
Art.broj Art.num.	F-1381	
Težina Weight	kg/m'	0.584
Opseg Perimeter	mm	231.87
Moment inercije	I _x (cm ⁴)	0.2323
	I _y (cm ⁴)	10.5738
Moments of inertia	W _x (cm ³)	0.2202
	W _y (cm ³)	2.5702
L	mm	6500

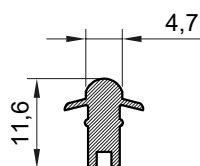

Vodilica Guide profile		
Art.broj Art.num.	F-1112	
Težina Weight	kg/m'	0.129
Opseg Perimeter	mm	45.43
L	mm	6500

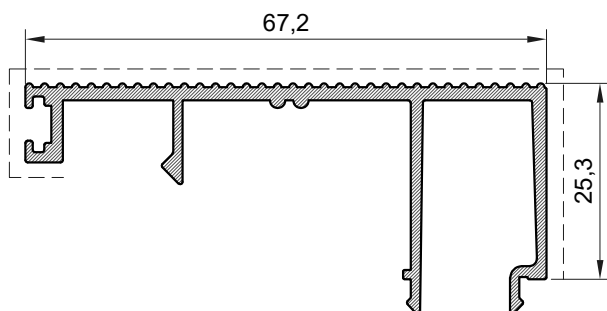

Lajsna-T120 Bead-T120		
Art.broj Art.num.	F-1444	
Težina Weight	kg/m'	0.676
Opseg Perimeter	mm	325.00
L	mm	6500

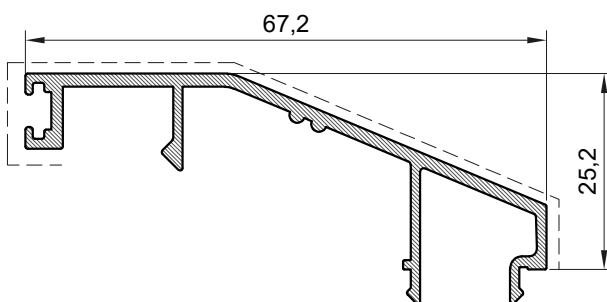

Lajsna-T120 Bead-T120		
Art.broj Art.num.	F-1445	
Težina Weight	kg/m'	0.540
Opseg Perimeter	mm	261.16
L	mm	6500

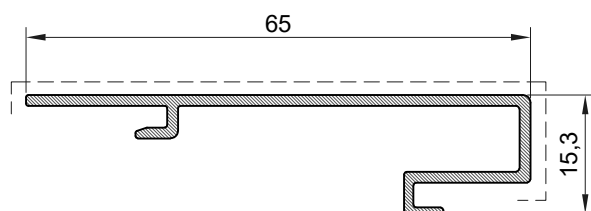

Lajsna-spoj dva krila Bead joint two sash-T120		
Art.broj Art.num.	F-1528	
Težina Weight	kg/m'	0.389
Opseg Perimeter	mm	211.27
L	mm	6500

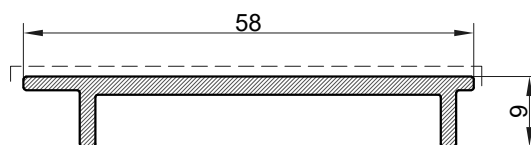
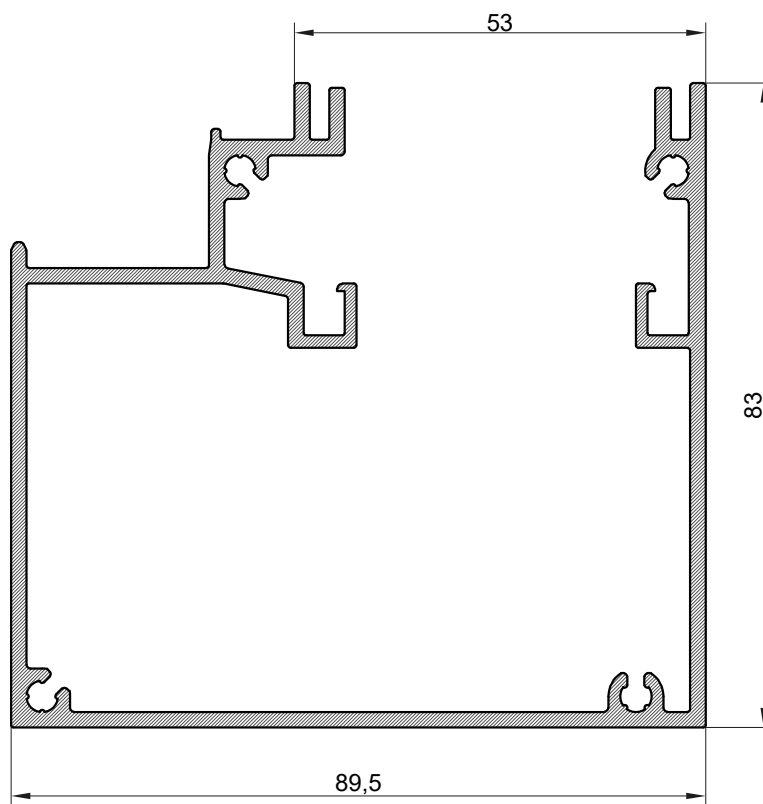
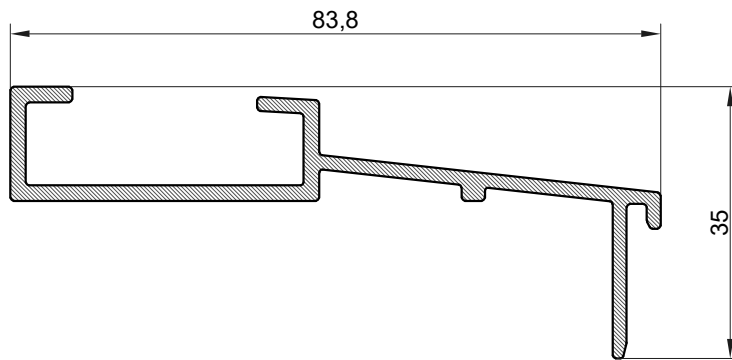

Al profil Al profile		
Art.broj Art.num.	F-1479	
Težina Weight	kg/m'	0.744
Opseg Perimeter	mm	288.51
Moment inerције	I _x (cm ⁴)	1.1825
	I _y (cm ⁴)	21.088
Moments of inertia	W _x (cm ³)	0.5264
	W _y (cm ³)	4.9570
L	mm	6500

Al profil Al profile		
Art.broj Art.num.	F-1480	
Težina Weight	kg/m'	2.064
Opseg Perimeter	mm	768.74
Moment inerције	I _x (cm ⁴)	63.570
	I _y (cm ⁴)	86.708
Moments of inertia	W _x (cm ³)	14.011
	W _y (cm ³)	18.723
L	mm	6500

Al profil Al profile		
Art.broj Art.num.	F-1478	
Težina Weight	kg/m'	0.424
Opseg Perimeter	mm	145.75
Moment inerције	I _x (cm ⁴)	0.0607
	I _y (cm ⁴)	4.8705
Moments of inertia	W _x (cm ³)	0.0854
	W _y (cm ³)	1.6294
L	mm	6500

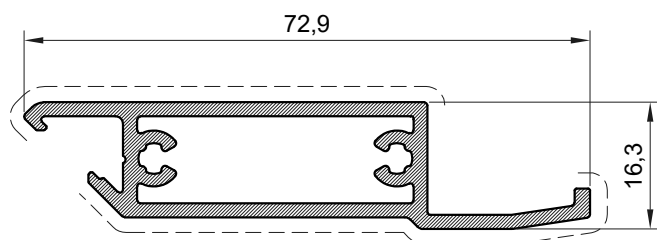

Al umetak-spoj pod 90° Al insert-joint under 90°		
Art.broj Art.num.	F-1532	
Težina Weight	kg/m'	0.810
Opseg Perimeter	mm	192.99
Moment inerције	I _x (cm ⁴)	1.020
	I _y (cm ⁴)	10.580
Moments of inertia	W _x (cm ³)	1.240
	W _y (cm ³)	2.720
L	mm	6500

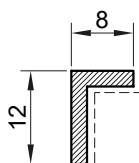

Al profil-držač točkića (T120) Al profile-držač točkića (T120)		
Art.broj Art.num.	F-1676	
Težina Weight	kg/m'	0.0972
Opseg Perimeter	mm	40.00
Moment inerције	I _x (cm ⁴)	0.0492
	I _y (cm ⁴)	0.0172
Moments of inertia	W _x (cm ³)	0.0642
	W _y (cm ³)	0.0303
L	mm	6500

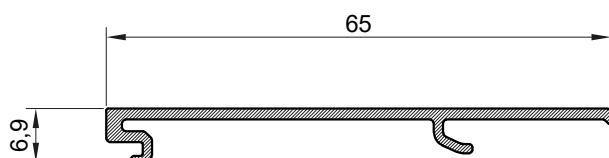

Profil maske (T 120) Profile caps (T 120)		
Art.broj Art.num.	F-1793	
Težina Weight	kg/m'	0.31
Opseg Perimeter	mm	167
Moment inercije	I _x (cm ⁴)	0.02
	I _y (cm ⁴)	4.55
Moments of inertia	W _x (cm ³)	0.05
	W _y (cm ³)	1.29
L	mm	6500

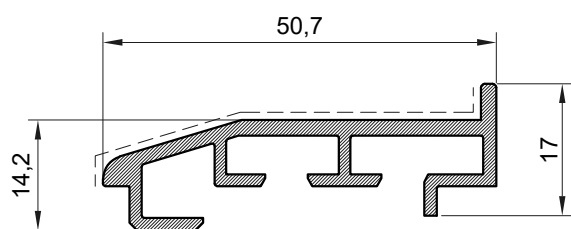

Umetak za nadsvjetlo Insert for overhead		
Art.broj Art.num.	F-1004	
Težina Weight	kg/m'	0.550
Opseg Perimeter	mm	228.46
L	mm	6500

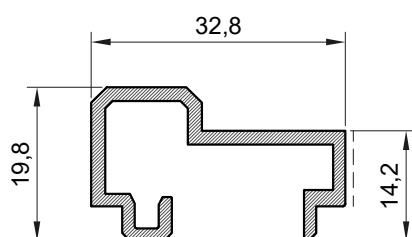

Umetak za nadsvjetlo Insert for overhead		
Art.broj Art.num.	F-1006	
Težina Weight	kg/m'	0.388
Opseg Perimeter	mm	167.40
L	mm	6500

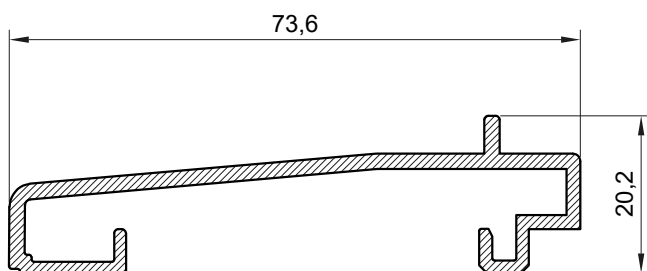

Profil za nadsvjetlo Profile for overhead		
Art.broj Art.num.	F-1775	
Težina Weight	kg/m'	0.673
Opseg Perimeter	mm	263
L	mm	6500

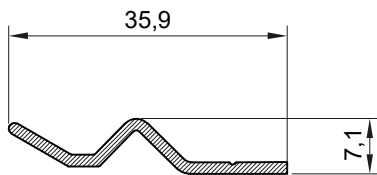

Al. profil Al. profile		
Art.broj Art.num.	F-1556	
Težina Weight	kg/m'	0.164
Opseg Perimeter	mm	85
L	mm	6500

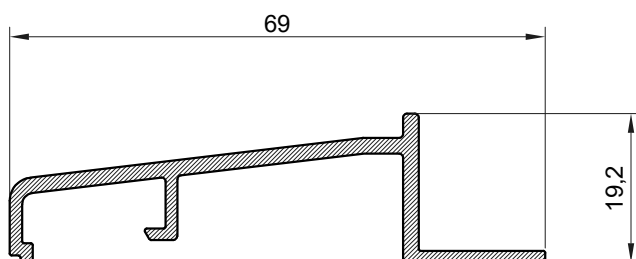

Umetak za nadsvjetlo Insert for overhead		
Art.broj Art.num.	F-1850	
Težina Weight	kg/m'	0.53
Opseg Perimeter	mm	215
L	mm	6500

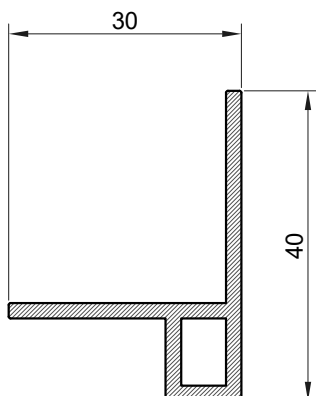

Profil za spoj pod 90° Profile for 90° connection		
Art.broj Art.num.	F-1858	
Težina Weight	kg/m'	0.456
Opseg Perimeter	mm	140
L	mm	6500

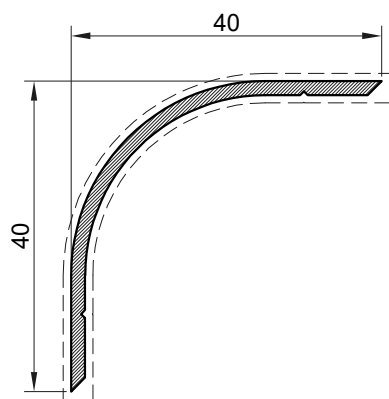

Al maska Al mask		
Art.broj Art.num.	F-0695	
Težina Weight	kg/m'	0.320
Opseg Perimeter	mm	138.00
L	mm	6500

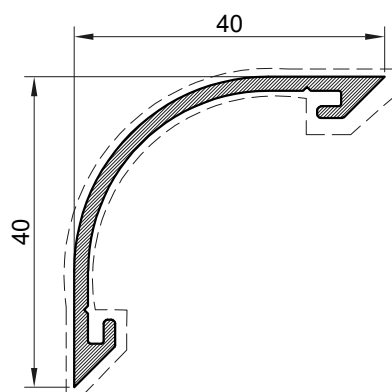

Al maska Al mask		
Art.broj Art.num.	F-1231	
Težina Weight	kg/m'	0.383
Opseg Perimeter	mm	158.93
L	mm	6500

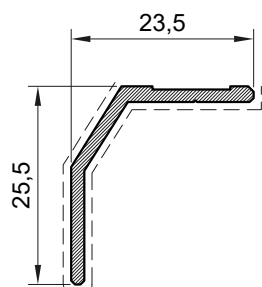

Al maska Al mask		
Art.broj Art.num.	F-1221	
Težina Weight	kg/m'	0.198
Opseg Perimeter	mm	89.06
L	mm	6500

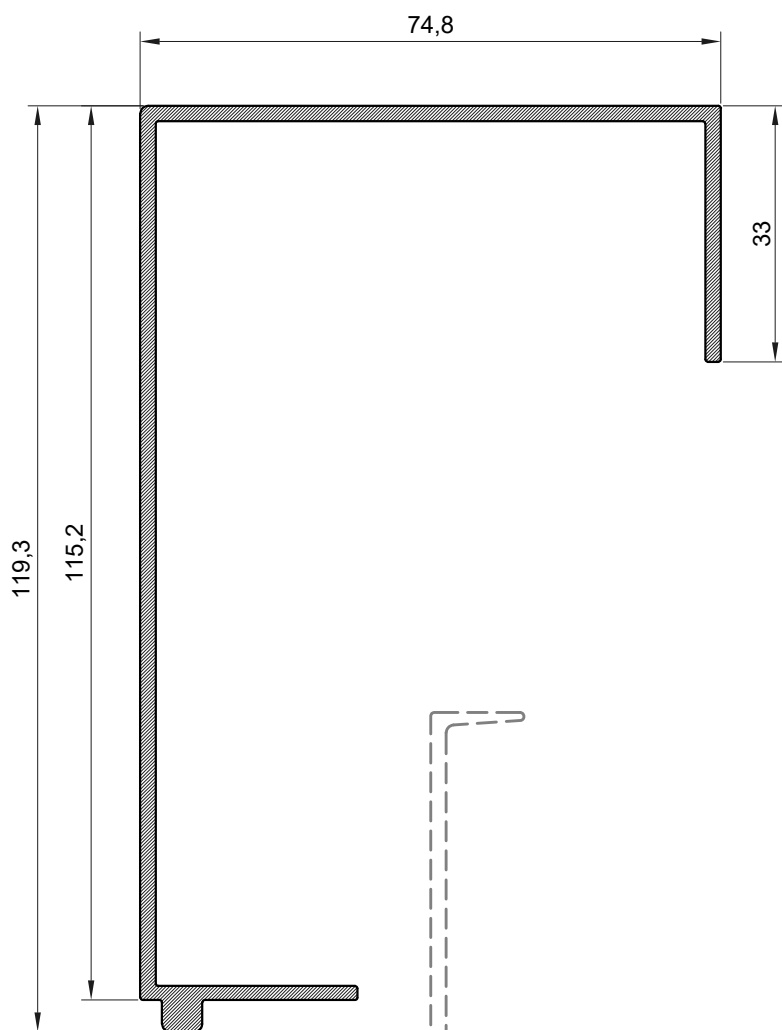

Al. profil Al. profile		
Art.broj Art.num.	F-1530	
Težina Weight	kg/m'	1.365
Opseg Perimeter	mm	499.50
L	mm	6500

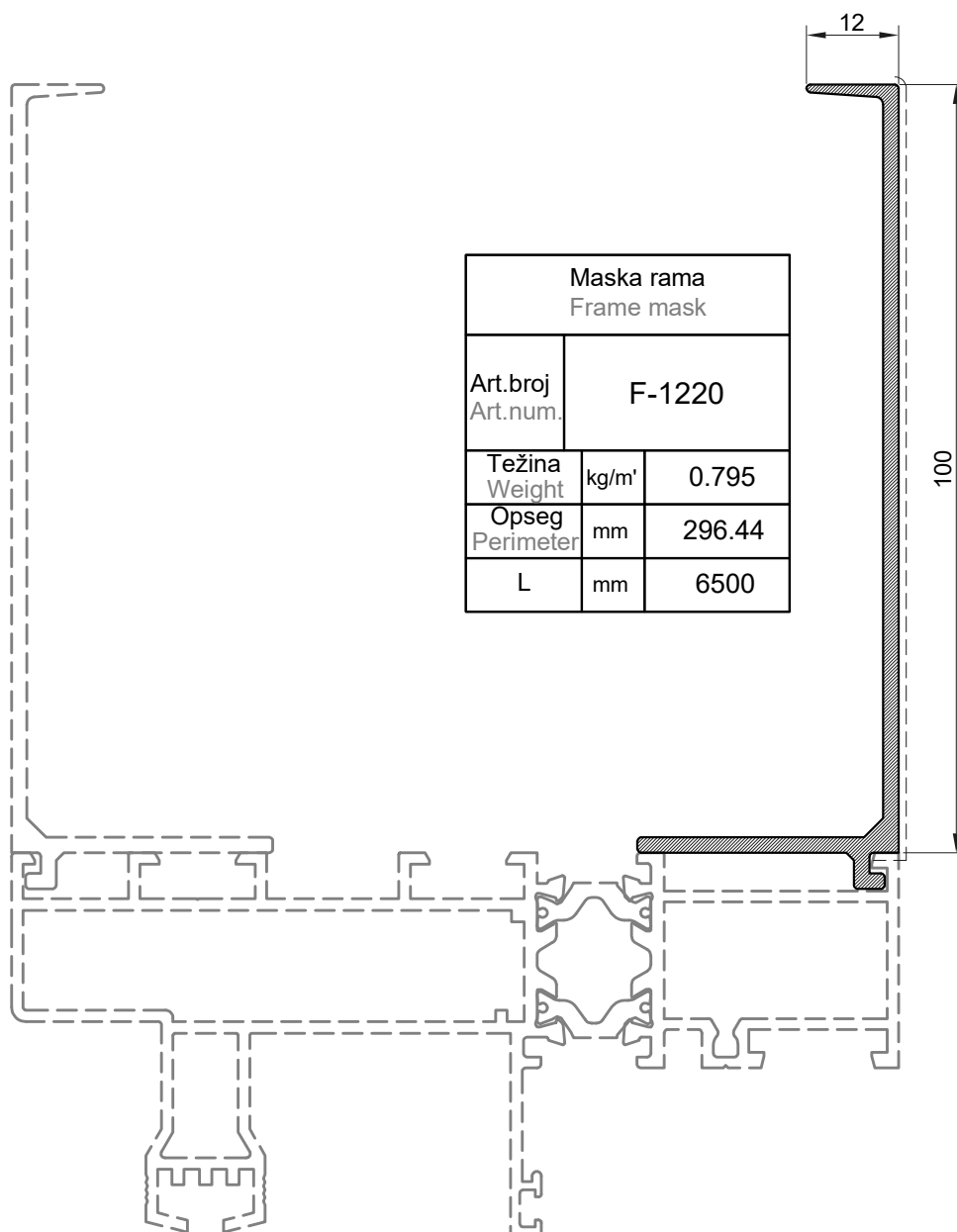

Maska rama Frame mask		
Art.broj Art.num.	F-1220	
Težina Weight	kg/m'	0.795
Opseg Perimeter	mm	296.44
L	mm	6500

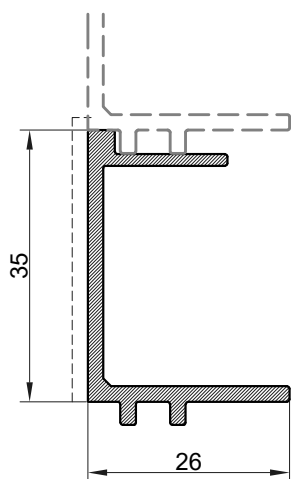

Al profil-proširenje rama Al profil-proširenje rama		
Art.broj Art.num.	F-1669	
Težina Weight	kg/m'	0.429
Opseg Perimeter	mm	163.34
Moment inercije	I _x (cm ⁴)	2.7845
	I _y (cm ⁴)	0.8150
Moments of inertia	W _x (cm ³)	1.2993
	W _y (cm ³)	0.4263
L	mm	6500

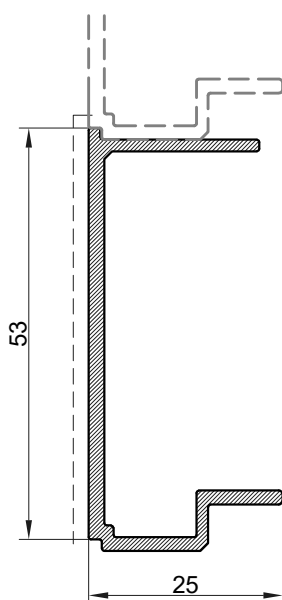

Al profil-proširenje rama Al profil-proširenje rama		
Art.broj Art.num.	F-1671	
Težina Weight	kg/m'	0.507
Opseg Perimeter	mm	207.59
Moment inercije	I _x (cm ⁴)	7.1939
	I _y (cm ⁴)	0.9521
Moments of inertia	W _x (cm ³)	2.4435
	W _y (cm ³)	0.5045
L	mm	6500

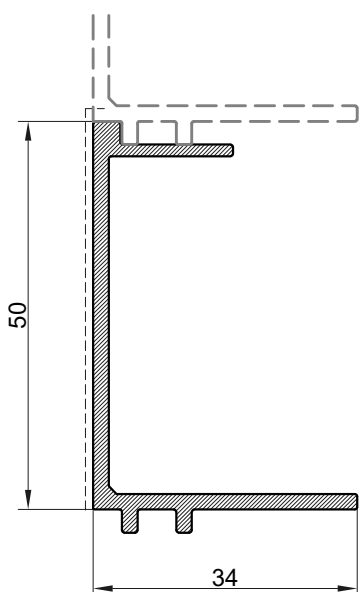

Al profil-proširenje rama Al profil-proširenje rama		
Art.broj Art.num.	F-1672	
Težina Weight	kg/m'	0.553
Opseg Perimeter	mm	209.34
Moment inercije	I _x (cm ⁴)	7.2055
	I _y (cm ⁴)	1.7653
Moments of inertia	W _x (cm ³)	2.3169
	W _y (cm ³)	0.6743
L	mm	6500

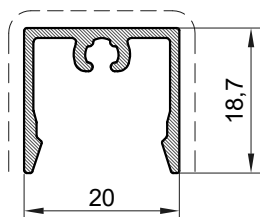

Maska profila ojačanja Reinforcement profile mask		
Art.broj Art.num.	NP-4184	
Težina Weight	kg/m'	0.243
Opseg Perimeter	mm	129
L	mm	6500

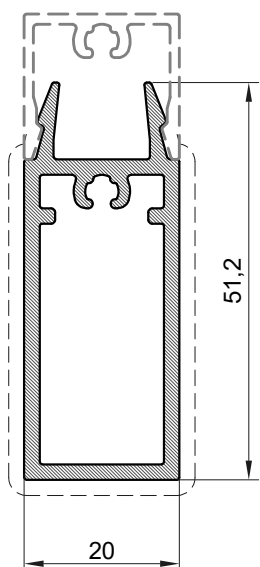

Profil ojačanja prečke Window crossbar reinforcement		
Art.broj Art.num.	F-1634	
Težina Weight	kg/m'	0.77
Opseg Perimeter	mm	160
L	mm	6500

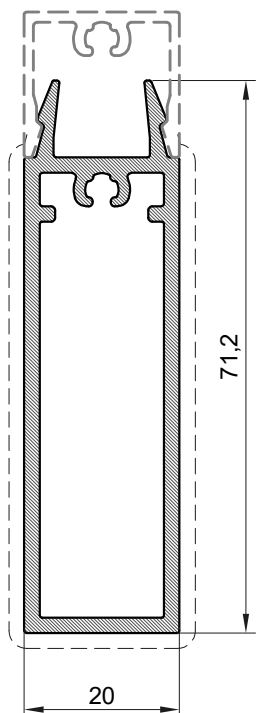

Profil ojačanja prečke Window crossbar reinforcement		
Art.broj Art.num.	F-NP-4183	
Težina Weight	kg/m'	0.99
Opseg Perimeter	mm	201
L	mm	6500

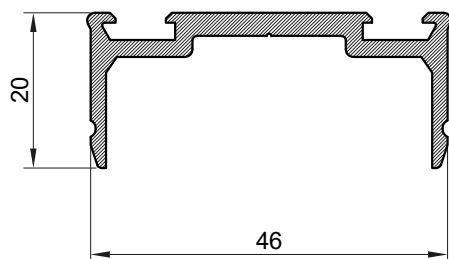

Maska profila ojačanja Reinforcement profile mask		
Art.broj Art.num.	FMO 50/20D	
Težina Weight	kg/m'	0.558
Opseg Perimeter	mm	185
L	mm	6500

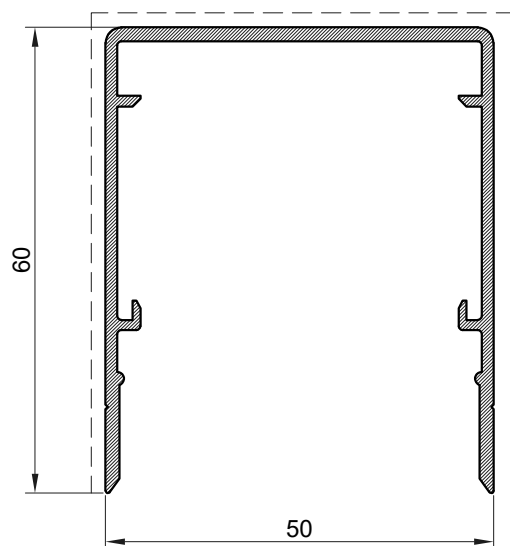

Profil ojačanja prečke Window crossbar reinforcement		
Art.broj Art.num.	FMO 50/61	
Težina Weight	kg/m'	0.785
Opseg Perimeter	mm	365
L	mm	6500

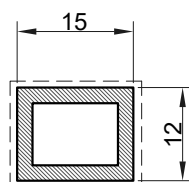

Al. profil Al. profile		
Art.broj Art.num.	F-1531	
Težina Weight	kg/m'	0.250
Opseg Perimeter	mm	54
L	mm	6500

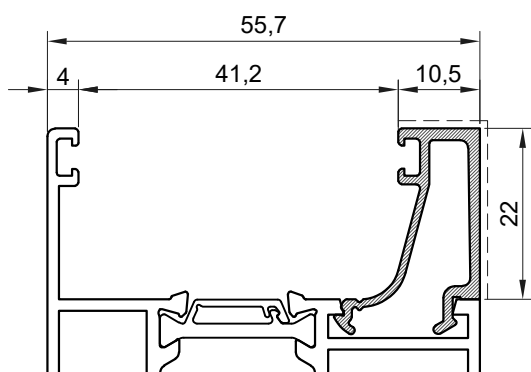

Staklo lajsna Glazing bead		
Art.broj Art.num.	Z40-636	
Težina Weight	kg/m'	0.261
Opseg Perimeter	mm	151.00
L	mm	6500

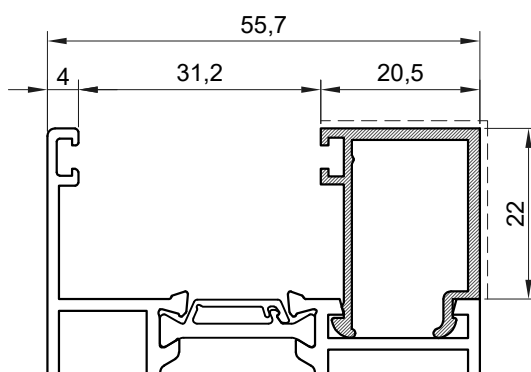

Staklo lajsna Glazing bead		
Art.broj Art.num.	Z40-644	
Težina Weight	kg/m'	0.275
Opseg Perimeter	mm	162.00
L	mm	6500

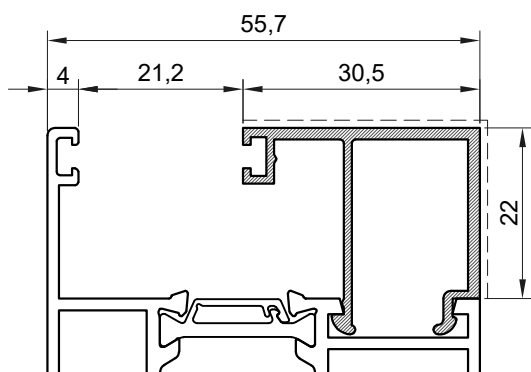

Staklo lajsna Glazing bead		
Art.broj Art.num.	Z40-653	
Težina Weight	kg/m'	0.348
Opseg Perimeter	mm	201.00
L	mm	6500

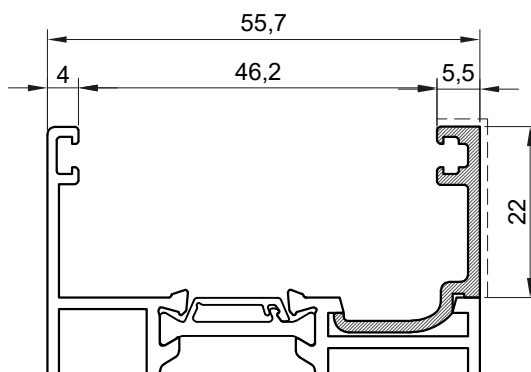

Staklo lajsna Glazing bead		
Art.broj Art.num.	Z40-656	
Težina Weight	kg/m'	0.215
Opseg Perimeter	mm	107.00
L	mm	6500

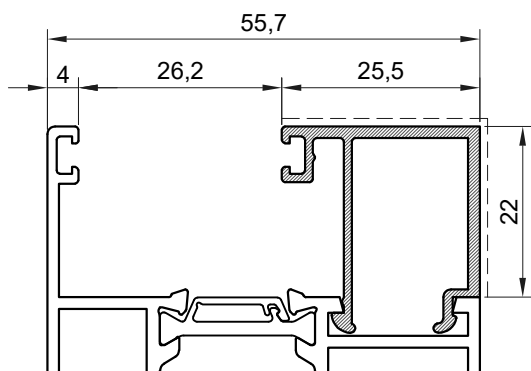

Staklo lajsna Glazing bead		
Art.broj Art.num.	Z40-658	
Težina Weight	kg/m'	0.318
Opseg Perimeter	mm	184.00
L	mm	6500

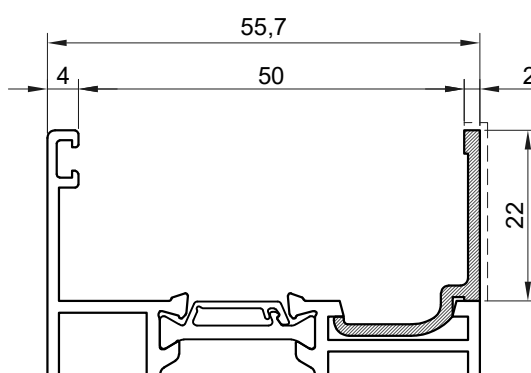

Staklo lajsna Glazing bead		
Art.broj Art.num.	Z40-660	
Težina Weight	kg/m'	0.179
Opseg Perimeter	mm	89.00
L	mm	6500

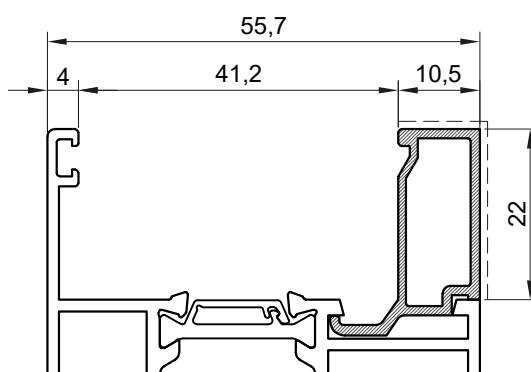

Staklo lajsna Glazing bead		
Art.broj Art.num.	Z40-664	
Težina Weight	kg/m'	0.243
Opseg Perimeter	mm	93.00
L	mm	6500

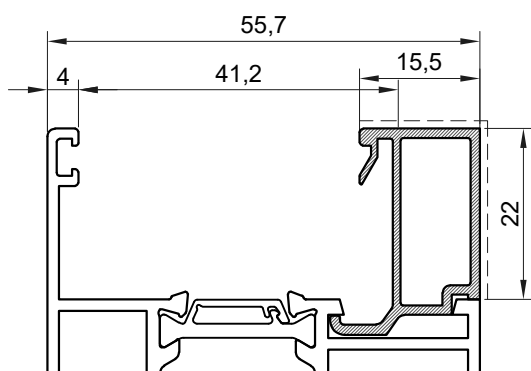

Staklo lajsna Glazing bead		
Art.broj Art.num.	Z40-665	
Težina Weight	kg/m'	0.271
Opseg Perimeter	mm	112.00
L	mm	6500

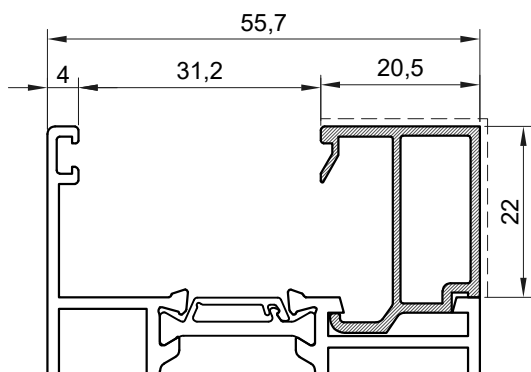

Staklo lajsna Glazing bead		
Art.broj Art.num.	Z40-666	
Težina Weight	kg/m'	0.289
Opseg Perimeter	mm	122.00
L	mm	6500

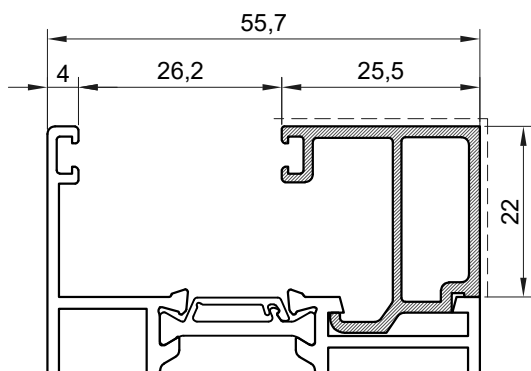

Staklo lajsna Glazing bead		
Art.broj Art.num.	Z40-667	
Težina Weight	kg/m'	0.358
Opseg Perimeter	mm	139.00
L	mm	6500

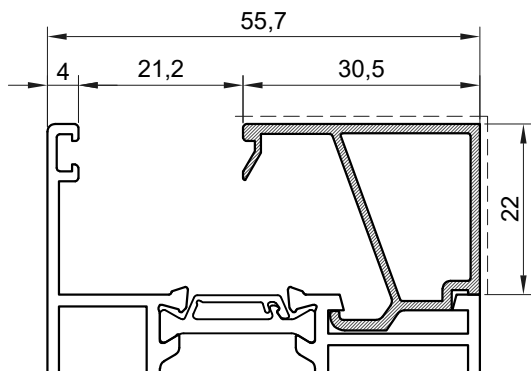

Staklo lajsna Glazing bead		
Art.broj Art.num.	Z40-668	
Težina Weight	kg/m'	0.326
Opseg Perimeter	mm	135.00
L	mm	6500

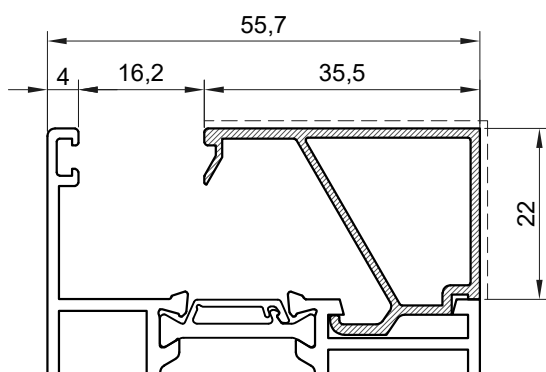

Staklo lajsna Glazing bead		
Art.broj Art.num.	Z40-669	
Težina Weight	kg/m'	0.347
Opseg Perimeter	mm	143.00
L	mm	6500

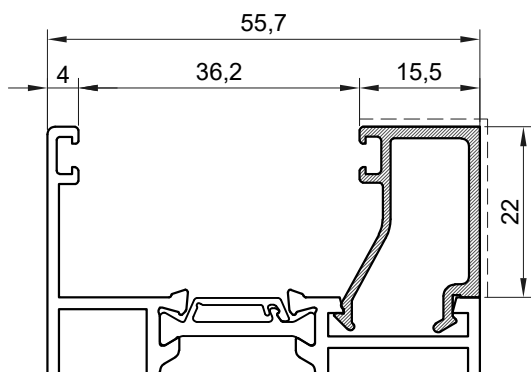

Staklo lajsna Glazing bead		
Art.broj Art.num.	M45-709	
Težina Weight	kg/m'	0.269
Opseg Perimeter	mm	156.00
L	mm	6500

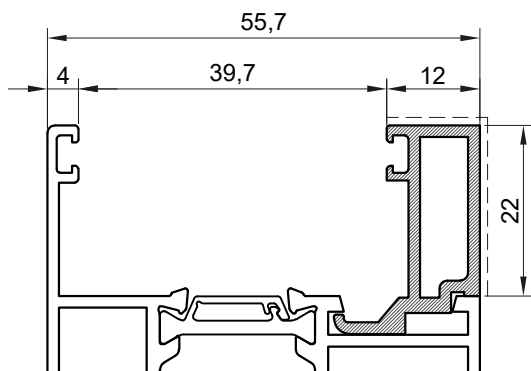

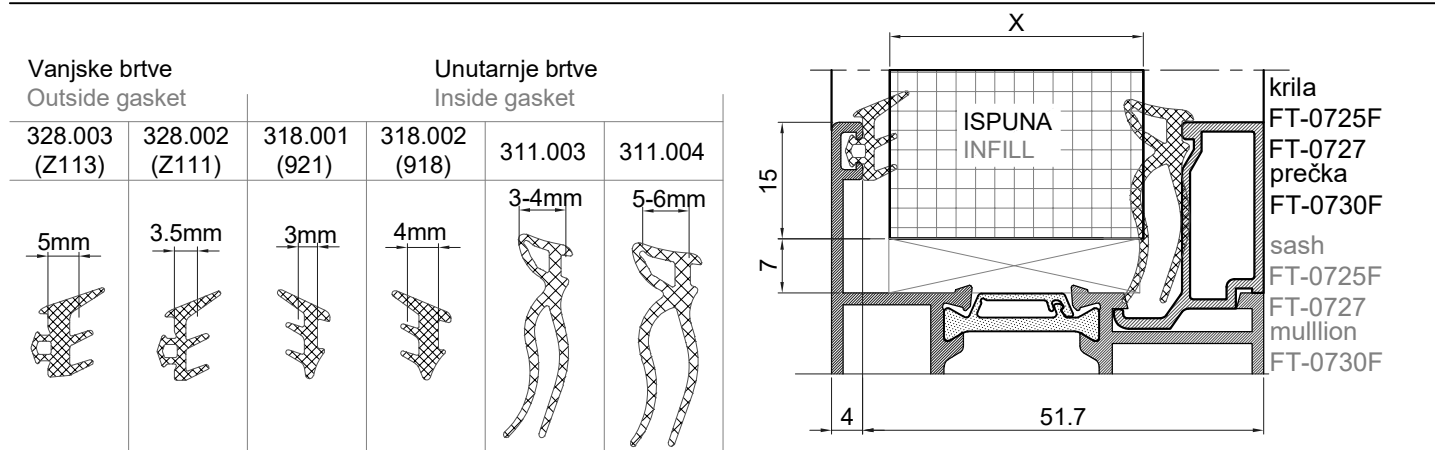

Staklo lajsna Glazing bead		
Art.broj Art.num.	F-0784	
Težina Weight	kg/m'	0.330
Opseg Perimeter	mm	105.40
L	mm	6500

Prikaz stakljenja Glazing





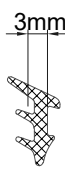
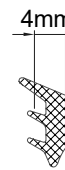

Ispuna X Glazing X	Vanjska brtva Outside gasket	Unutarnja brtva Inside gasket	LAJSNE ZA STAKLO Glazing bead		
10-11	328.003	311.004			
12	328.003	311.003 (318.002)			
13	328.002	318.002			
14	328.002	311.003 (318.002)	Z40-653		
15-16	328.003	311.004			
17	328.003	311.003 (318.002)			
18	328.002	318.002			
19	328.002	311.003 (318.002)	Z40-658		
20-21	328.003	311.004			
22	328.003	311.003 (318.002)			
23	328.002	318.002			
24	328.002	311.003 (318.002)	Z40-644		
25-26	328.003	311.004			
27	328.003	311.003 (318.002)			
28	328.002	318.002			
29	328.002	311.003 (318.002)	M45-709		
30-31	328.003	311.004			
32	328.003	318.002 (311.003)			
33	328.002	318.002			
34	328.002	311.003 (318.002)	Z40-636		
35-36	328.003	311.004			
37	328.003	318.002 (311.003)			
38	328.002	318.002	Z40-656		
39	328.003	311.004			
40-41	328.003	318.002			
42	328.002	318.002 (311.003)			
43-44	318.001	318.001	Z40-660		

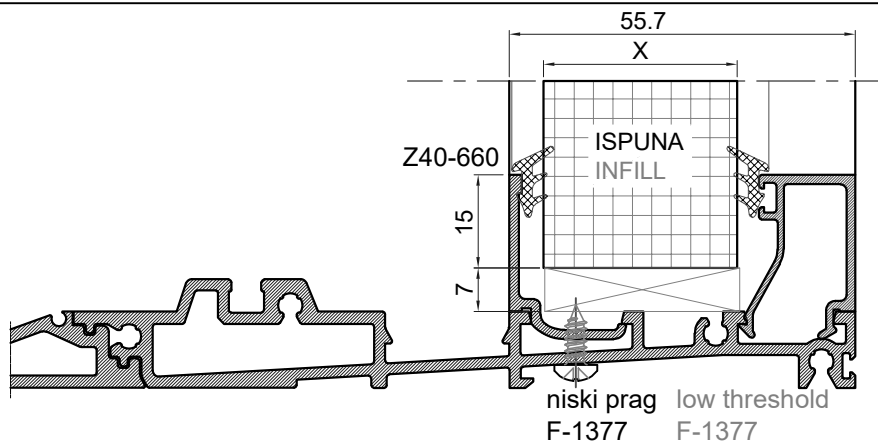
Brtve
Gaskets

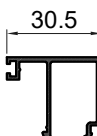
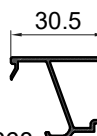
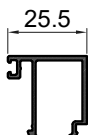
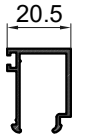
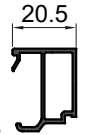
318.001 (921)	318.002 (918)	311.003	311.004
3mm	4mm	3-4mm	5-6mm
			

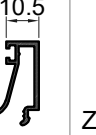
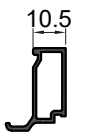

Ispuna X Glazing X	Vanjska brtva Outside gasket	Unutarnja brtva Inside gasket	LAJSNE ZA STAKLO Glazing bead			
13	318.002	311.004				
14	318.001	311.004				
15	318.002	318.002				
16	318.001	318.001 (311.003)	Z40-653			
18	318.002	311.004				
19	318.001	311.004				
20	318.002	318.002				
21	318.001	318.001 (311.003)	Z40-658			
23	318.002	311.004				
24	318.001	311.004				
25	318.002	318.002				
26	318.001	318.001 (311.003)	Z40-644			
28	318.002	311.004				
29	318.001	311.004				
30	318.002	318.002				
31	318.001	318.001 (311.003)	M45-709			
33	318.002	311.004				
34	318.001	311.004				
35	318.002	318.002				
36	318.001	318.001 (311.003)	Z40-636			
38	318.002	311.004				
39	318.002	311.004				
40	318.002	318.002	Z40-656			
41	318.001	318.001 (311.003)				
42	318.002	311.004				
43	318.001	311.004				
44	318.001	318.002	Z40-660			

TERMO 120

Presjeci s kliznim krilom FT-0725
Cross-sections with sliding sash FT-0725

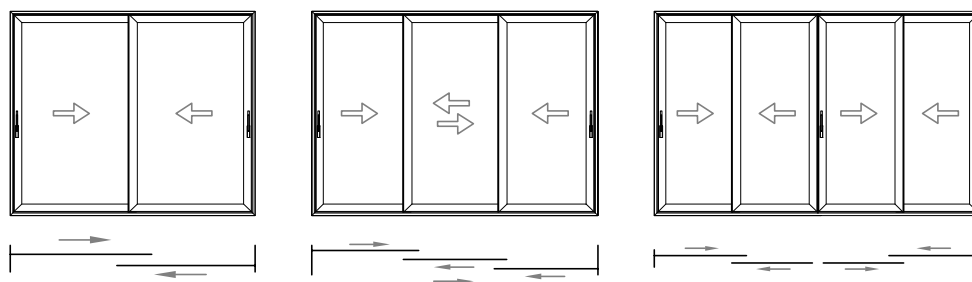

Presjeci s kliznim krilom FT-0727
Cross-sections with sliding sash FT-0727

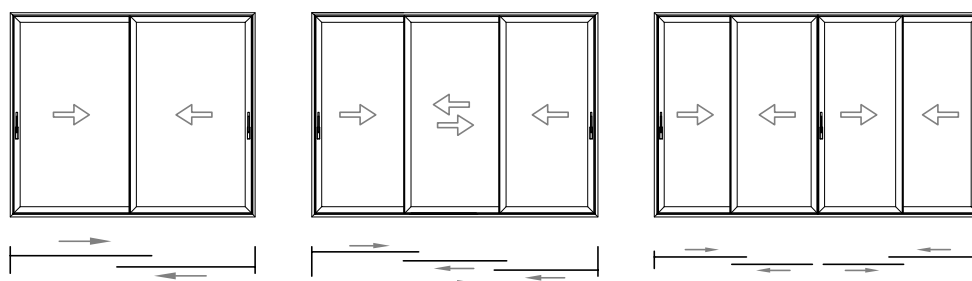

Presjeci s podiznom-kliznim krilom FT-0725
Cross-sections with lift-slide sash FT-0725

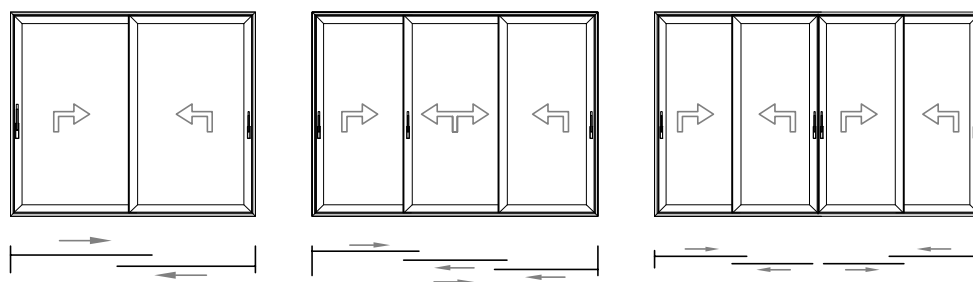

Presjeci s podiznom-kliznim krilom FT-0727
Cross-sections with lift-slide sash FT-0727

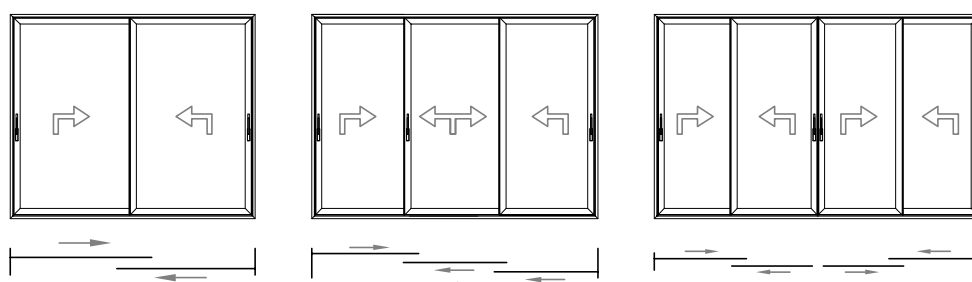

Presjeci s kliznim krilom FT-0725 i integriranim fiksnim poljem
Sections with FT-0725 sliding sash and integrated fixed field

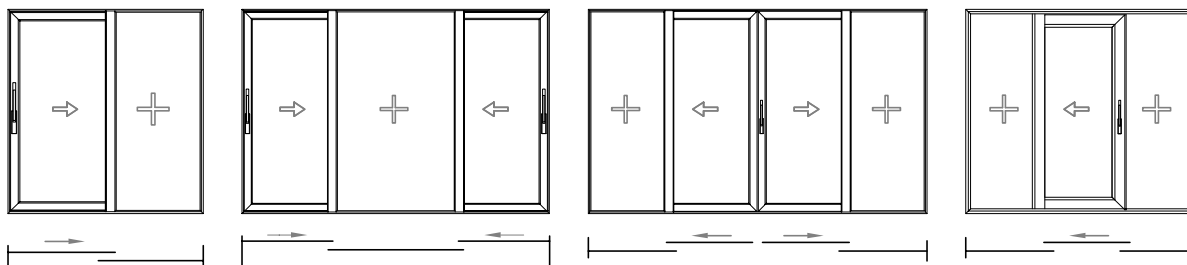

Presjeci s kliznim krilom FT-0727 i integriranim fiksnim poljem
Sections with FT-0727 sliding sash and integrated fixed field

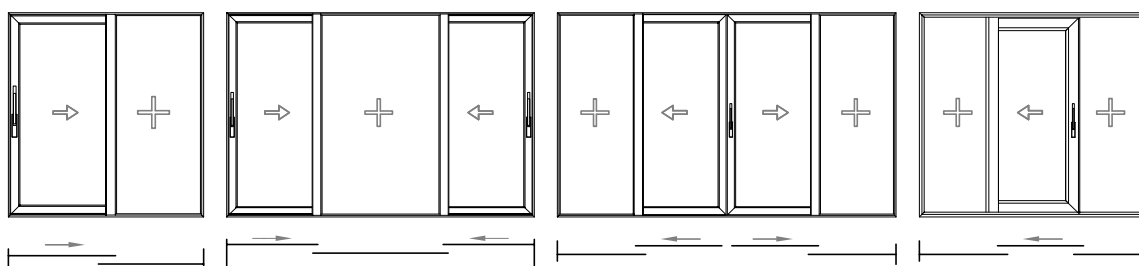

Presjeci s podizno-kliznim krilom FT-0725 i integriranim fiksnim poljem
Sections with lift-slide sash FT-0725 and integrated fixed field

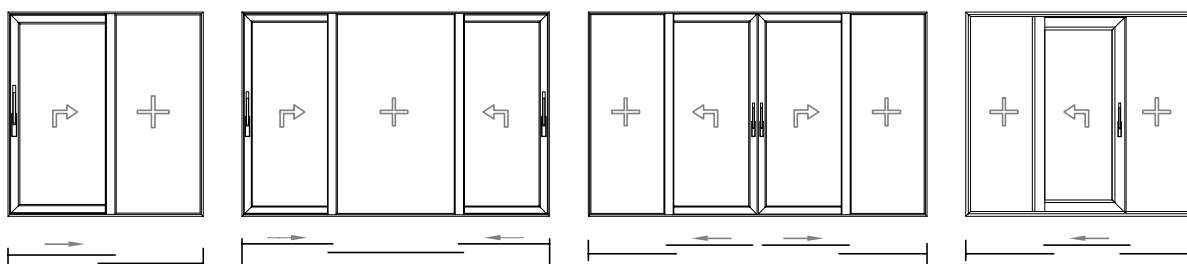

Presjeci s podizno-kliznim krilom FT-0727 i integriranim fiksnim poljem
Sections with lift-slide sash FT-0727 and integrated fixed field

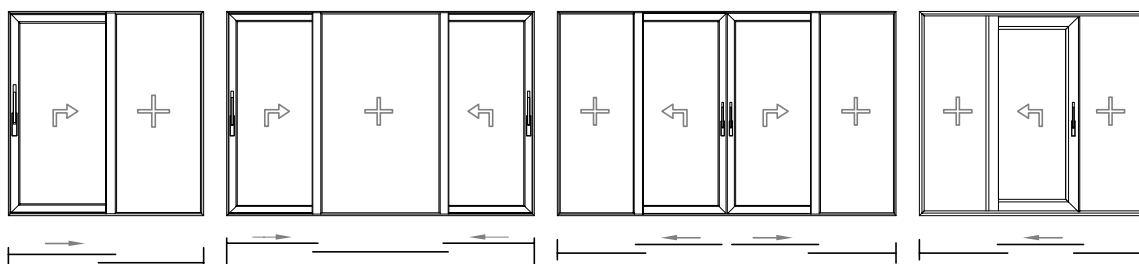

Presjeci s krilom FT-0727 + FT-0728 sa uskim srednjim vertikalnim pojasom
Sash sections FT-0727 + FT-0728 with narrow middle vertical zone

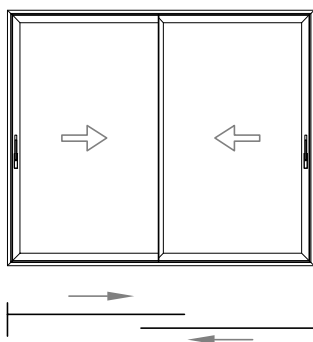

Klizno krilo
Slide sash
403.05.021

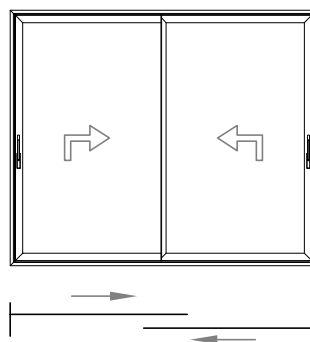

Podizno-klizno krilo
Lift & Slide sash
403.05.046

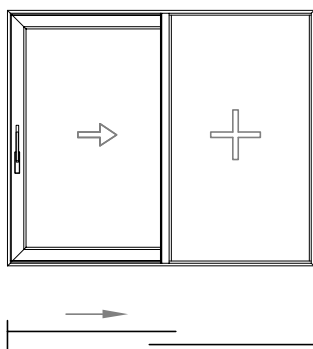

Klizno krilo s integriranim fiksnim poljem
Slide sash with integrated fixed field
403.05.114

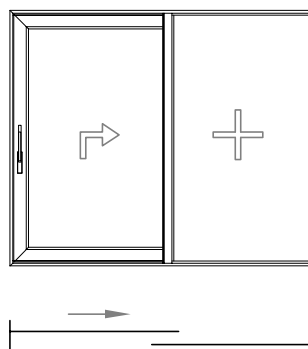

Podizno-klizno krilom s integriranim fiksnim poljem
Lift & Slide sash with integrated fixed field
403.05.134

Presjeci s krilom FT-0725 klizno

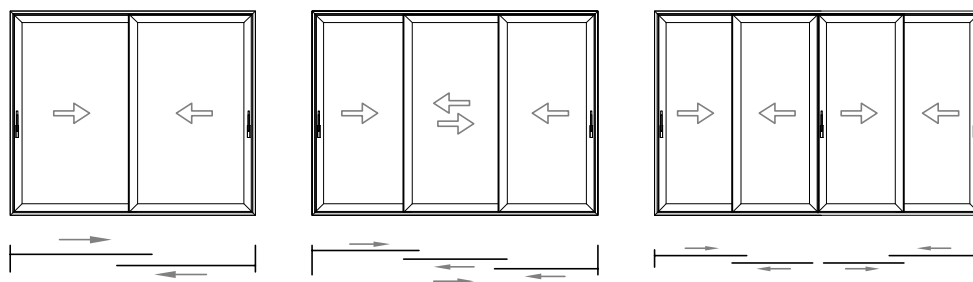

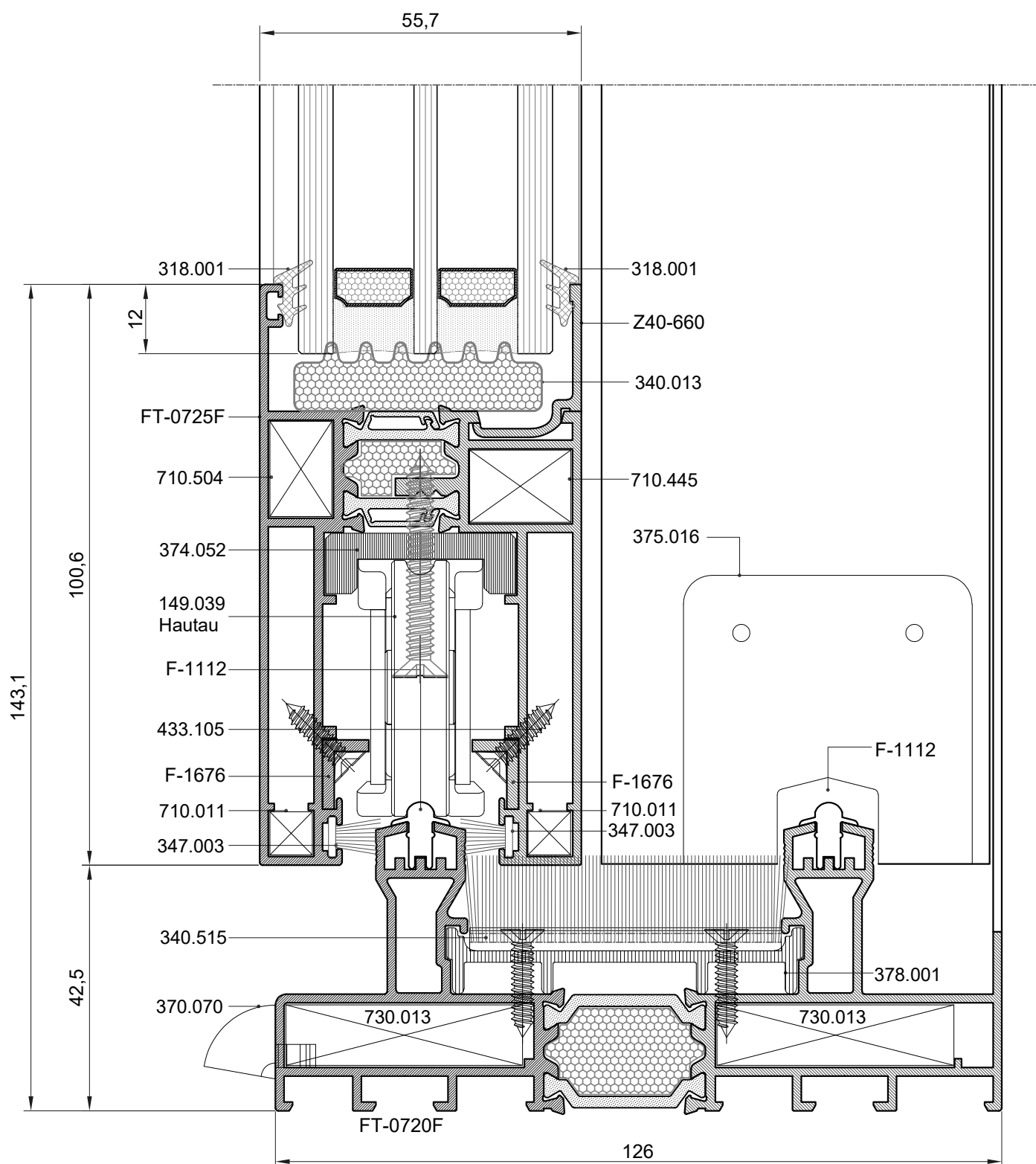
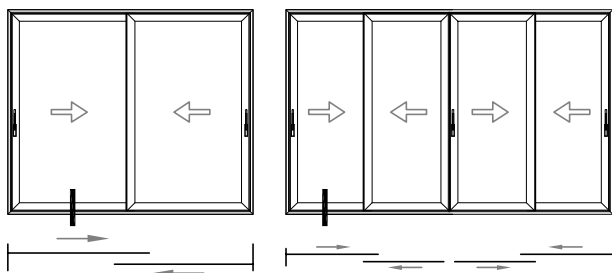

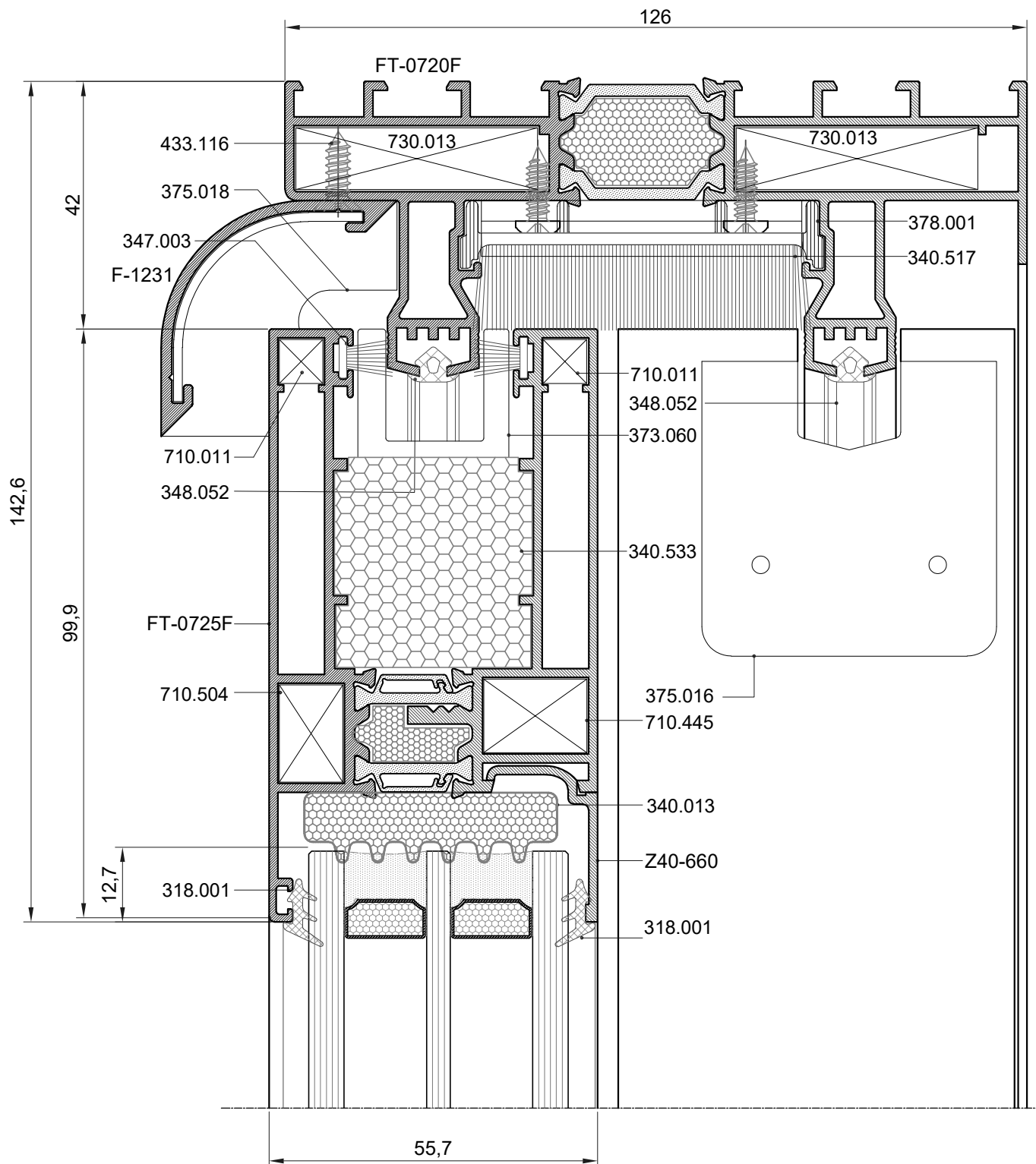
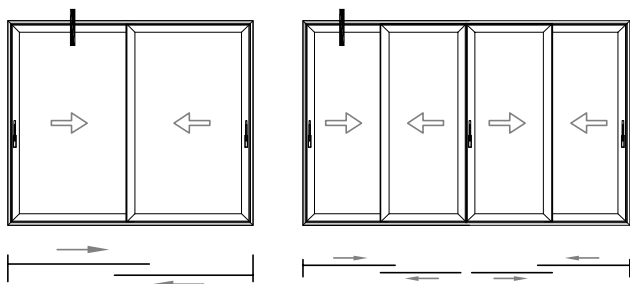

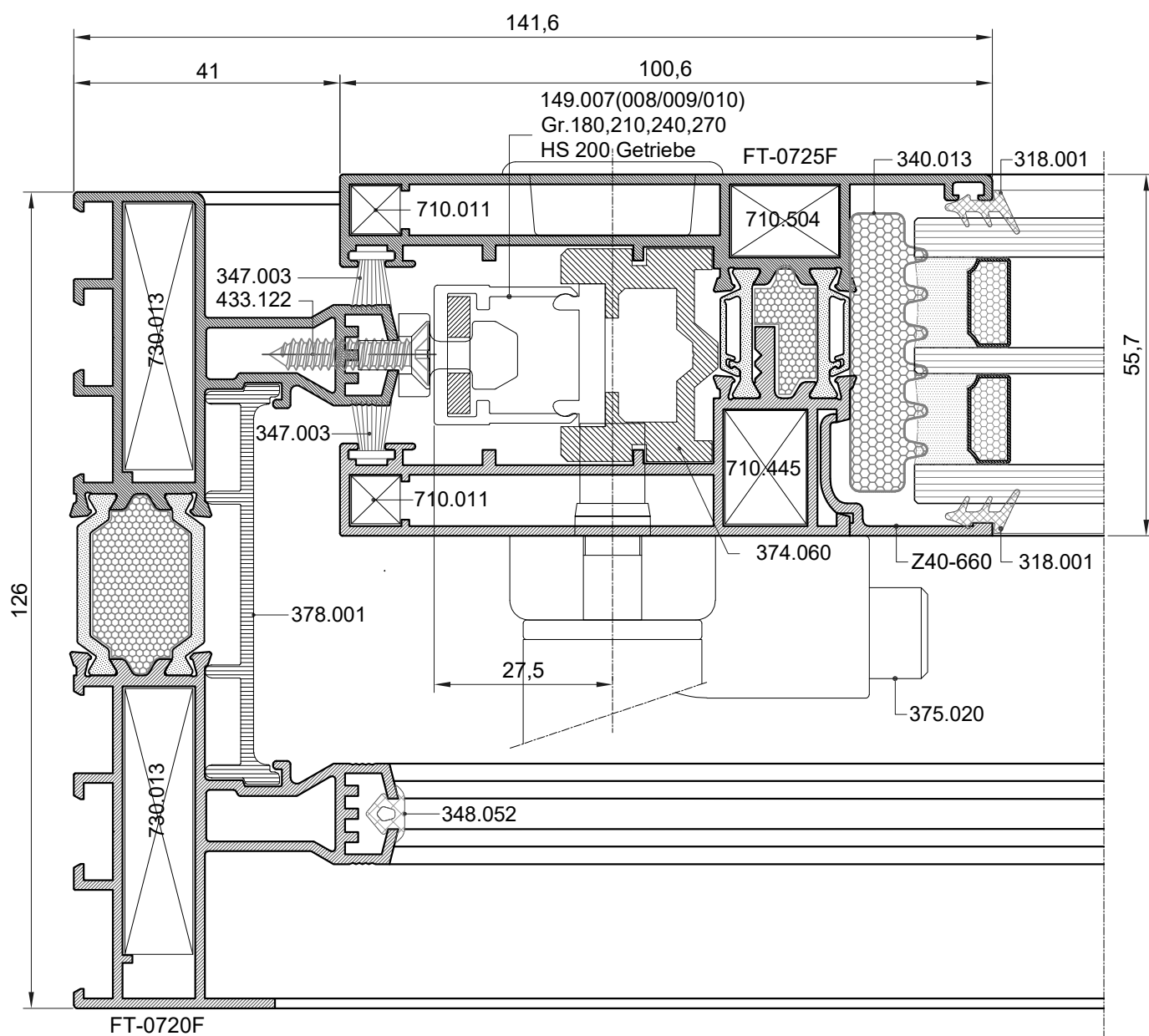
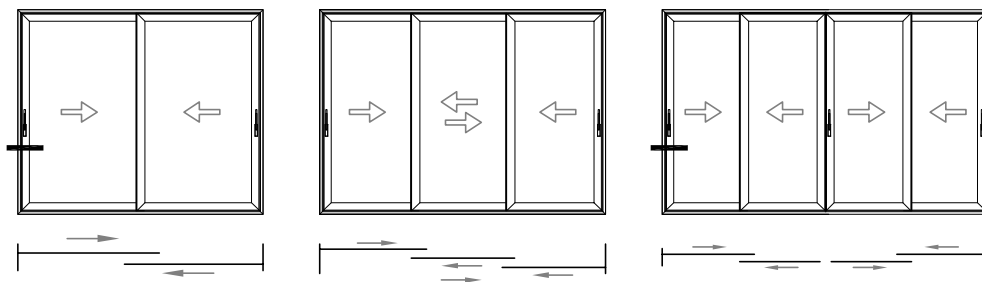

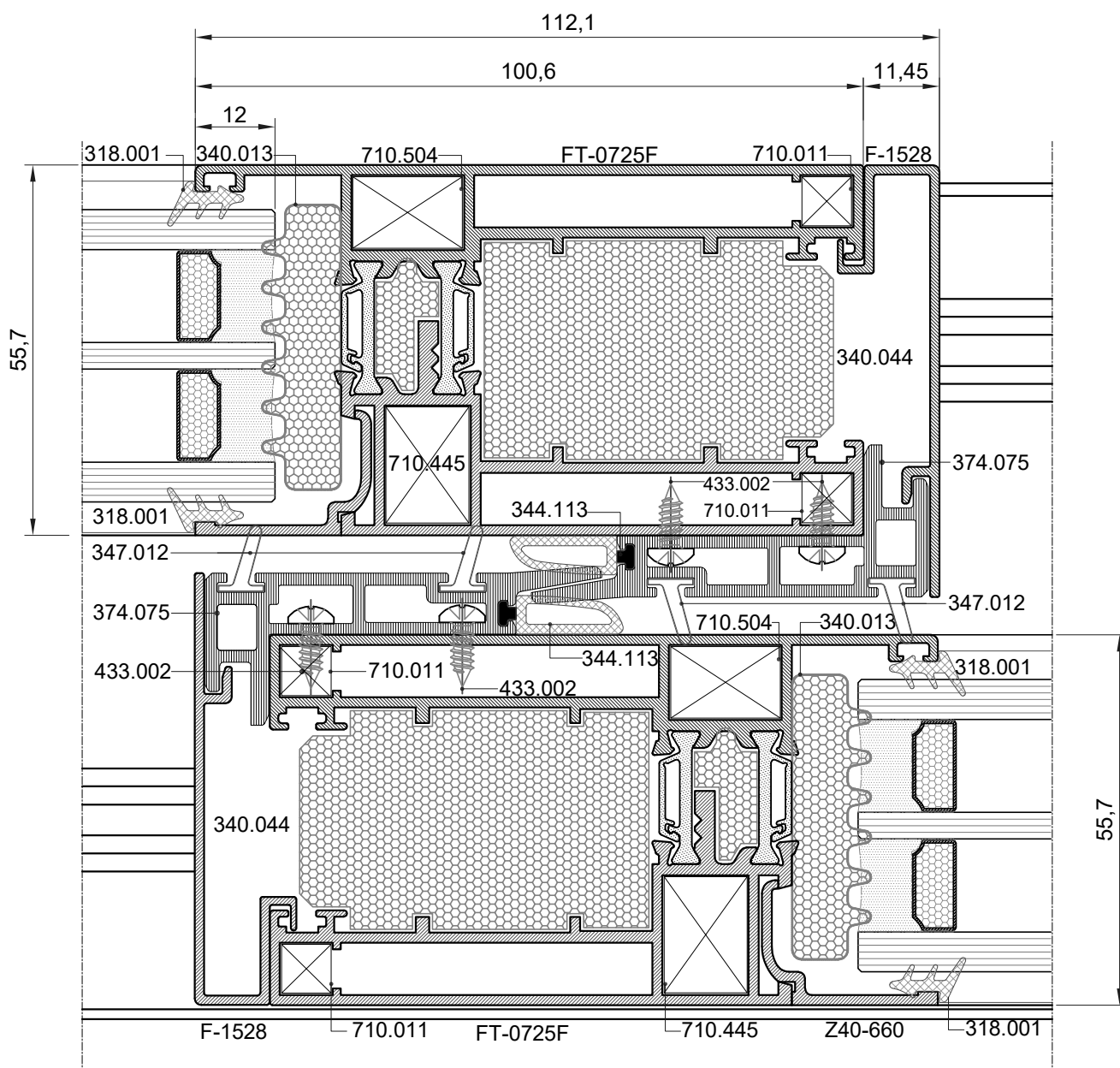
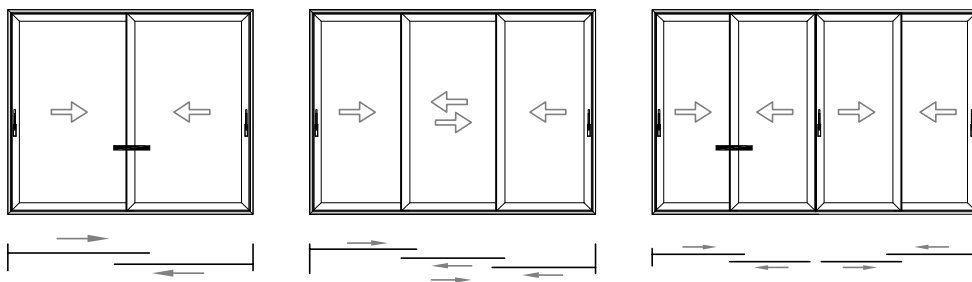

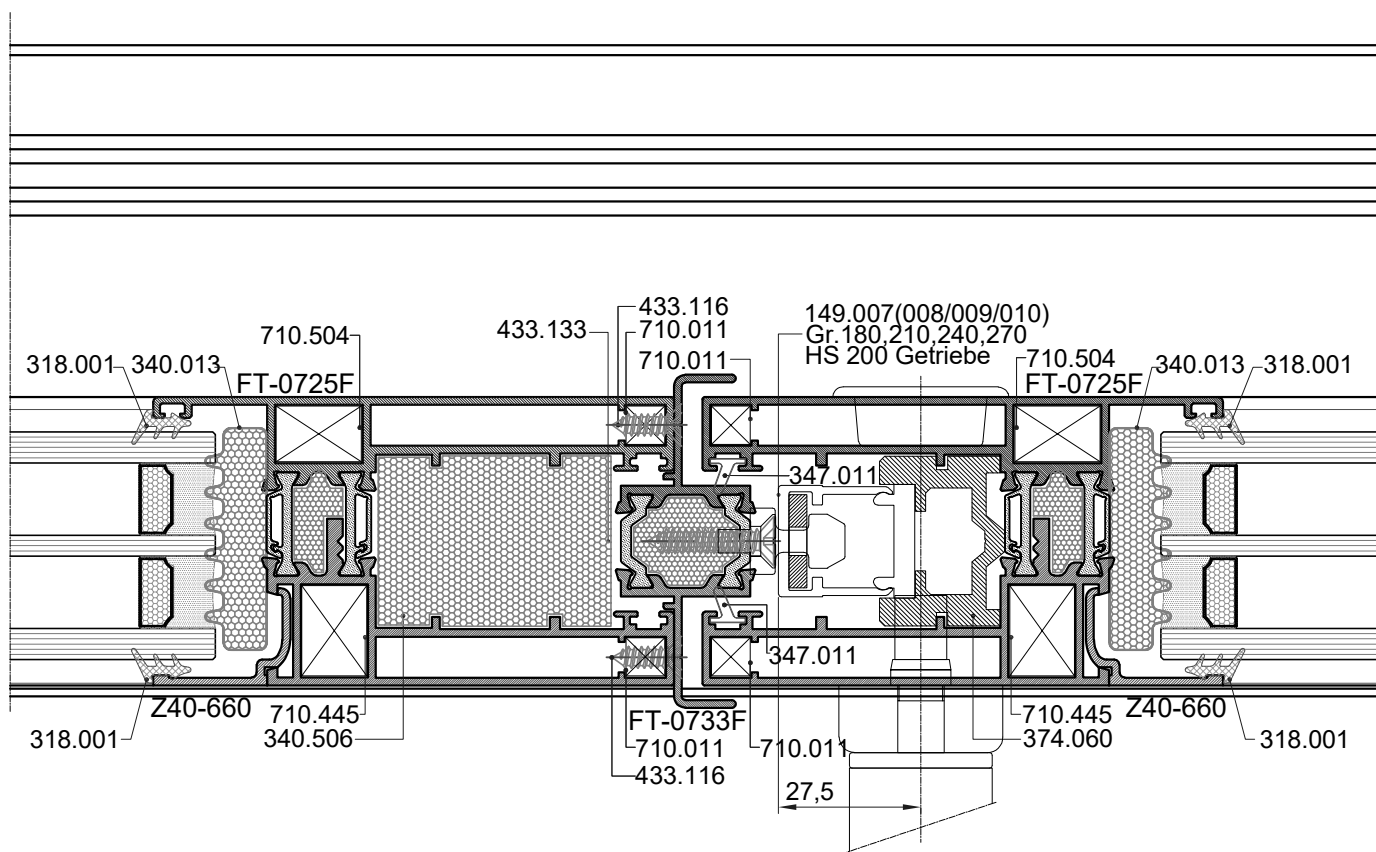
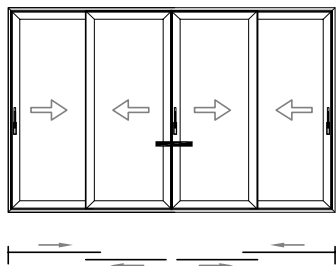

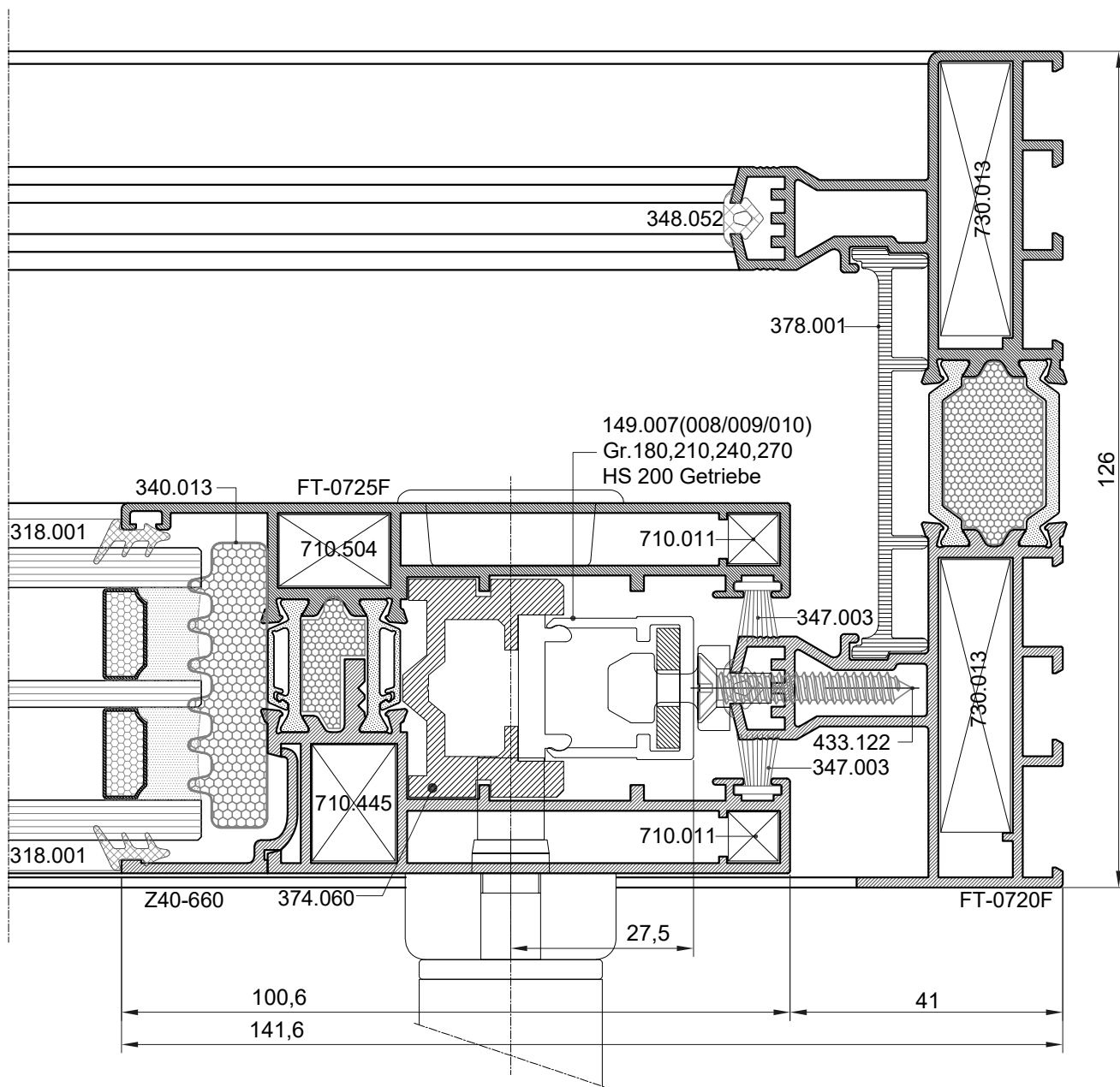
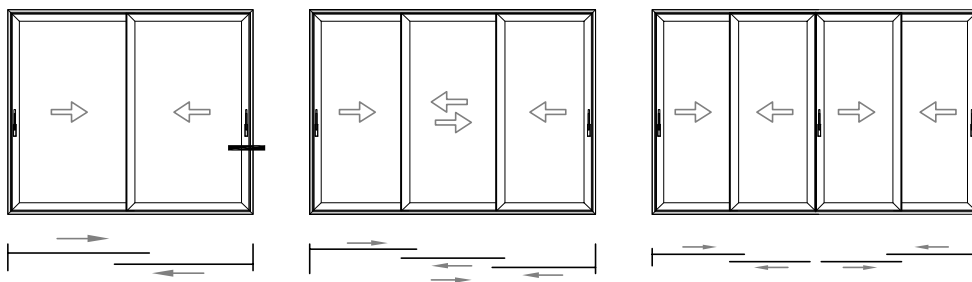

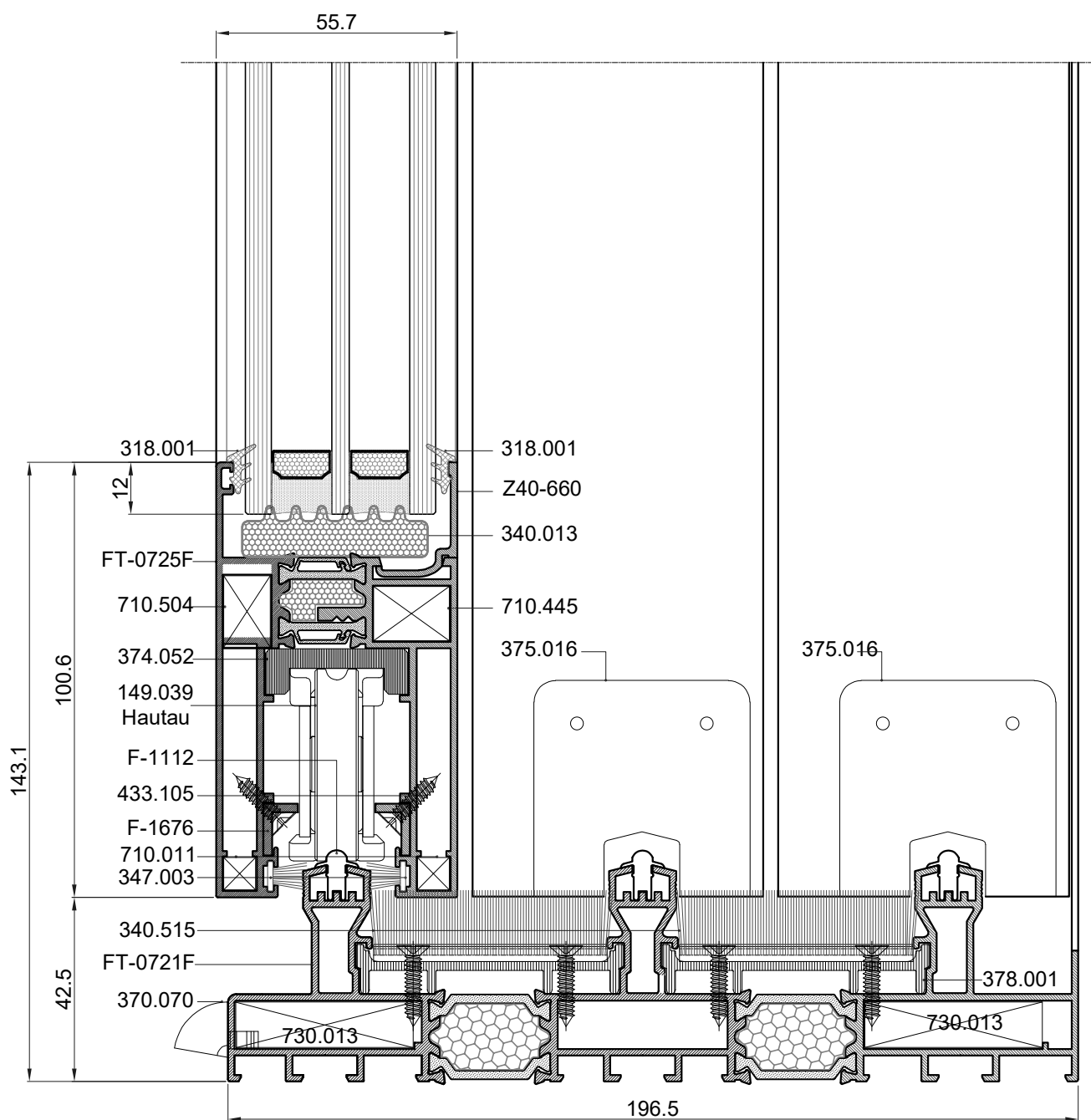
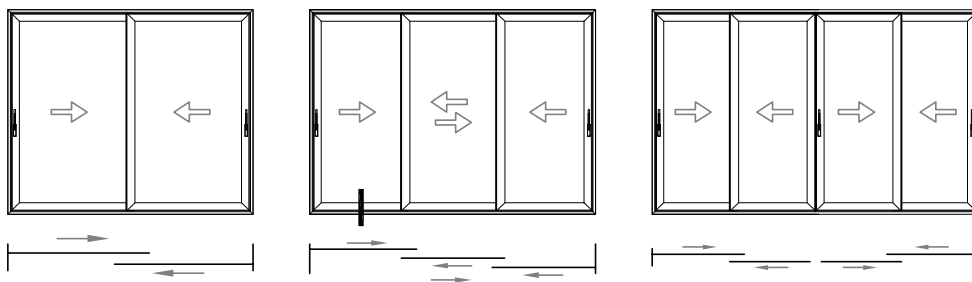

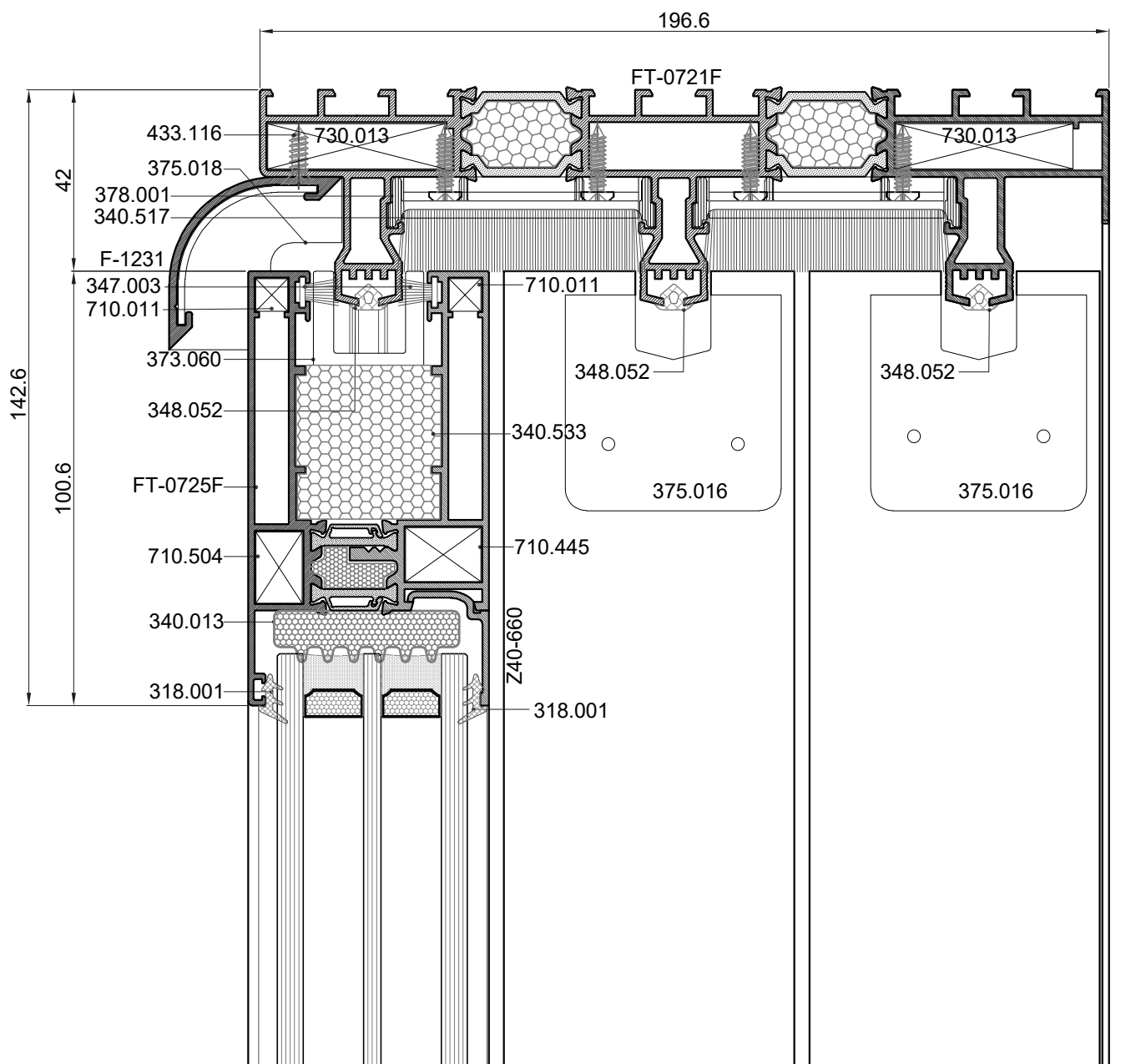
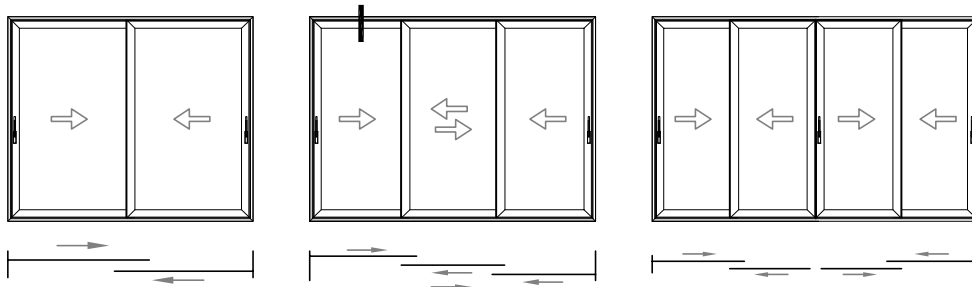

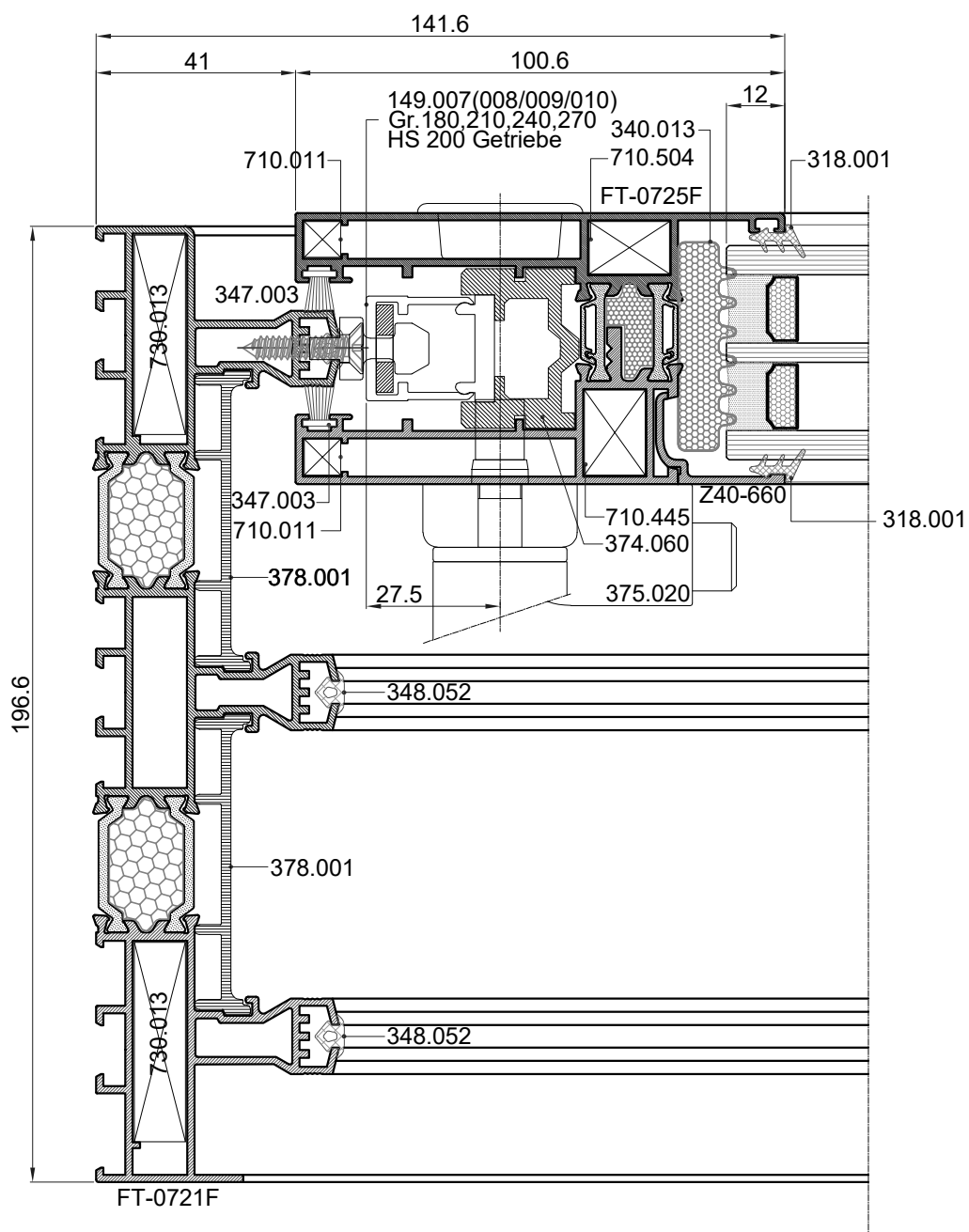
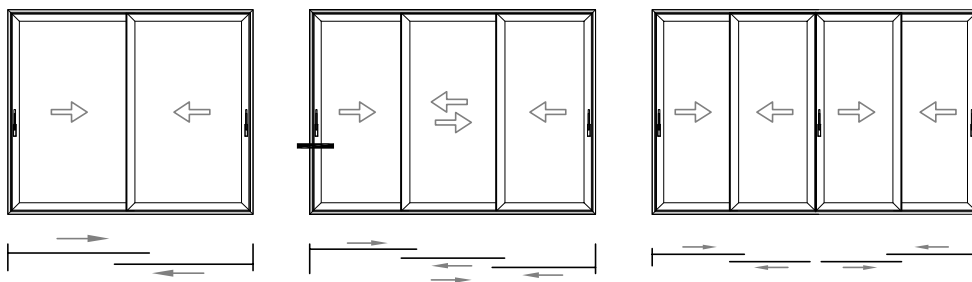

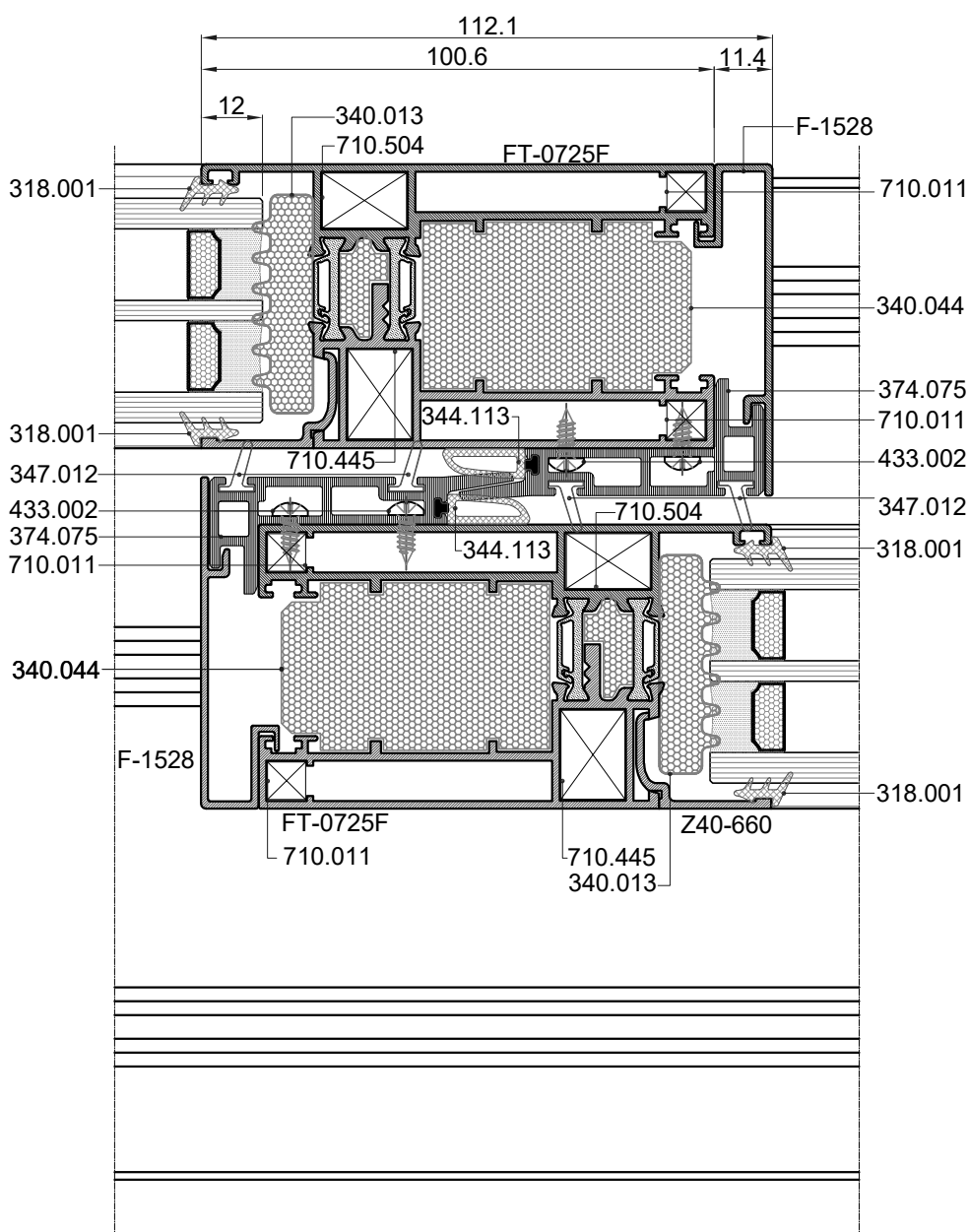
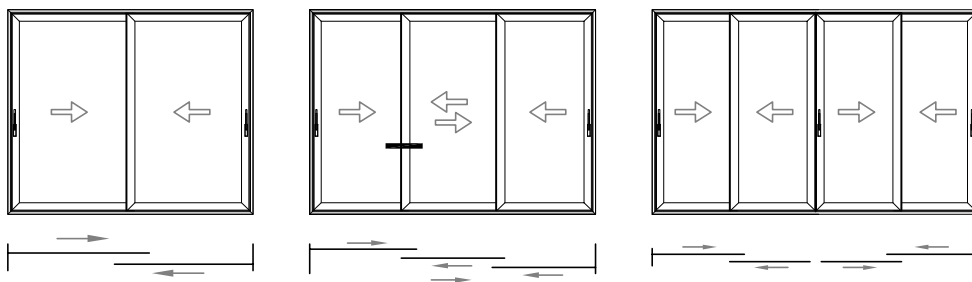

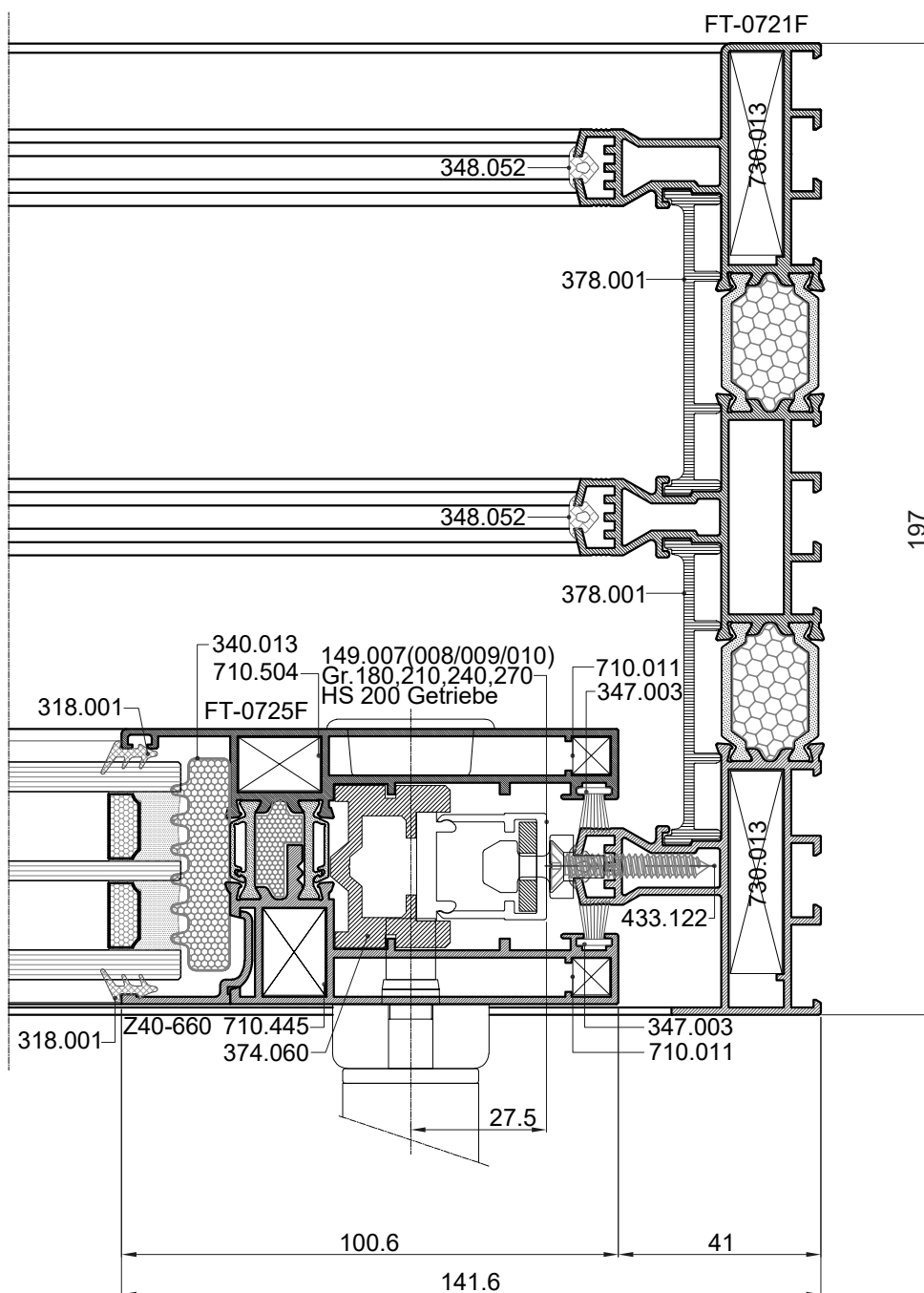
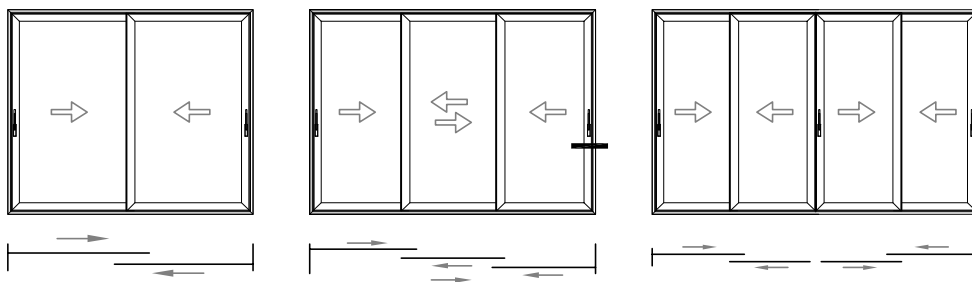

Presjeci s krilom FT-0727 klizno

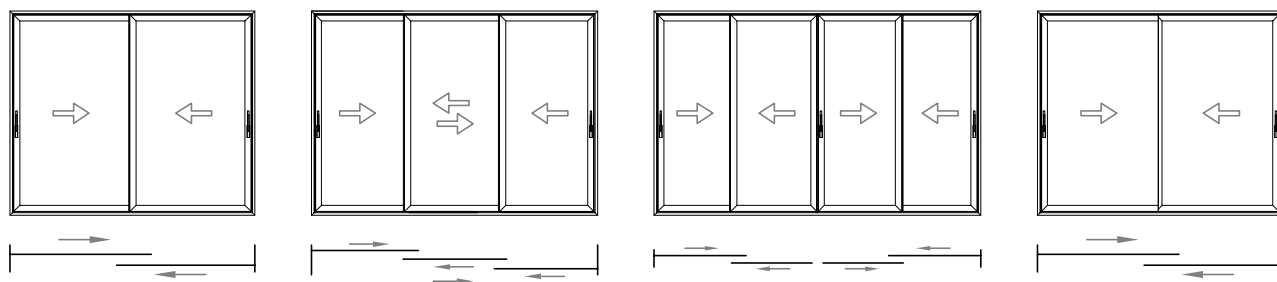

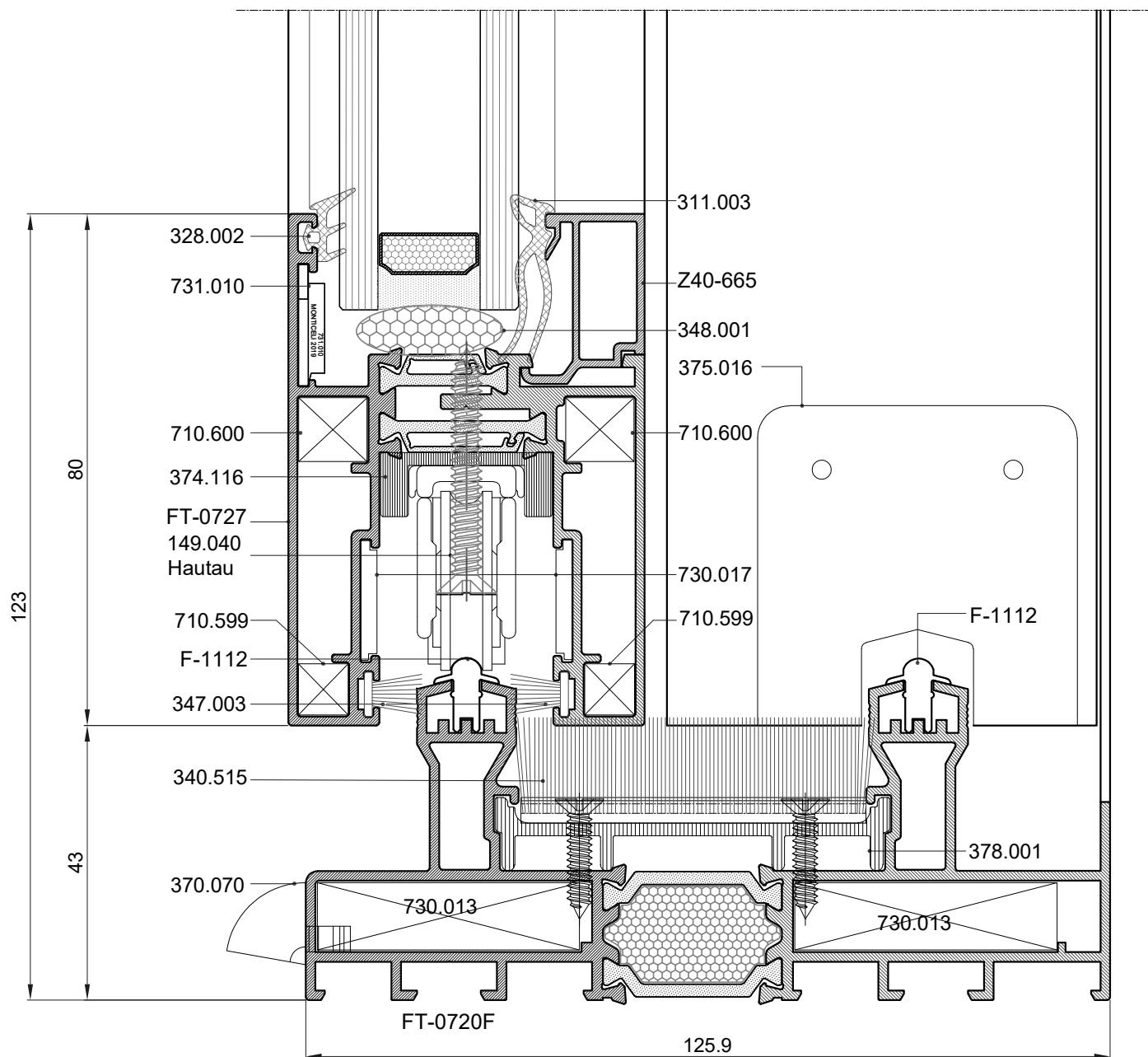
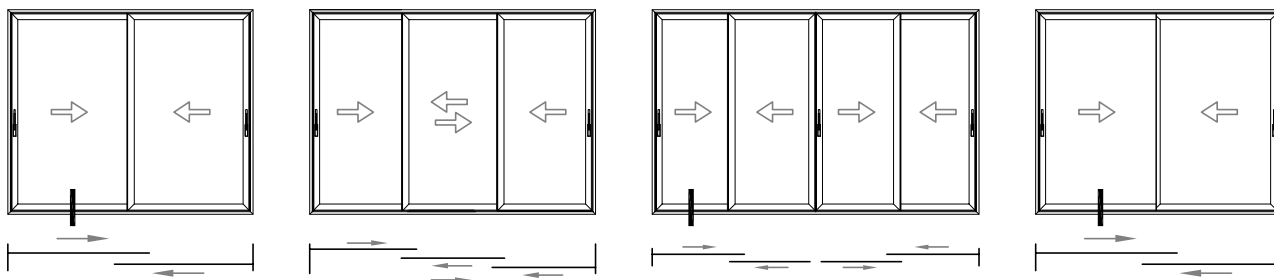

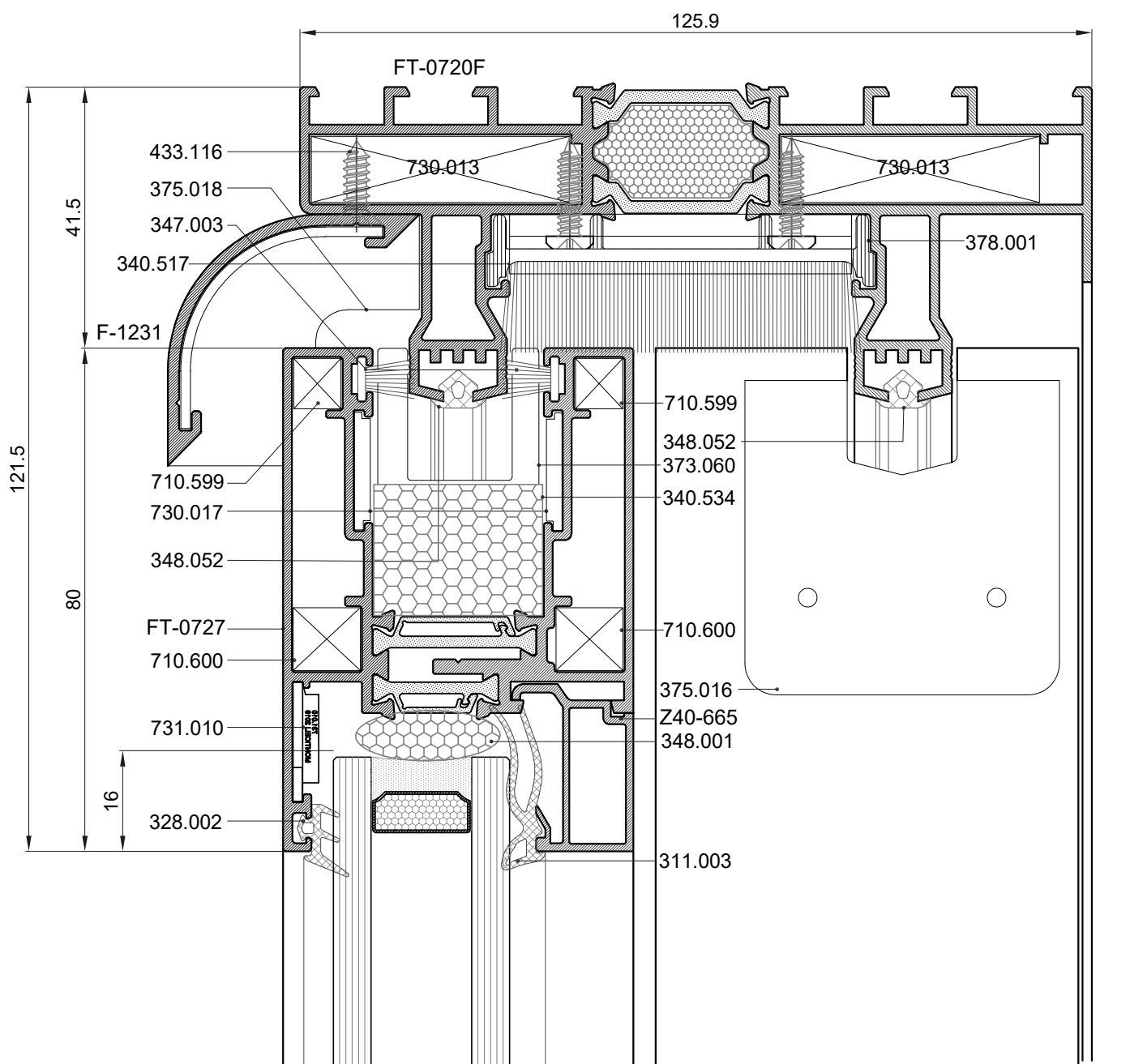
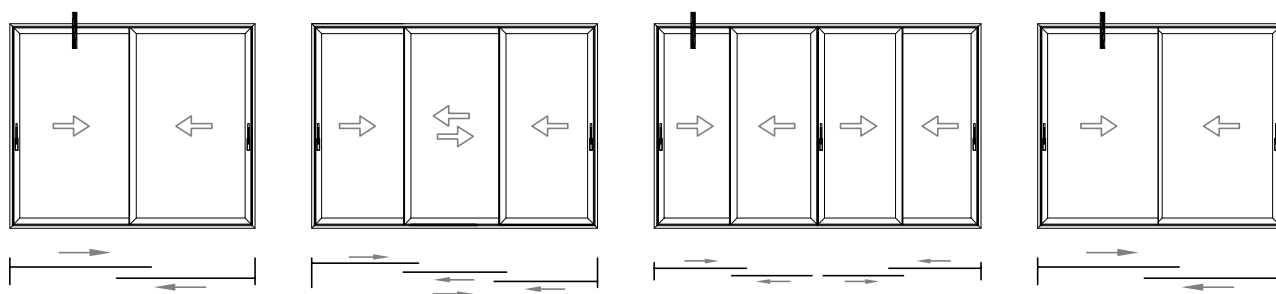

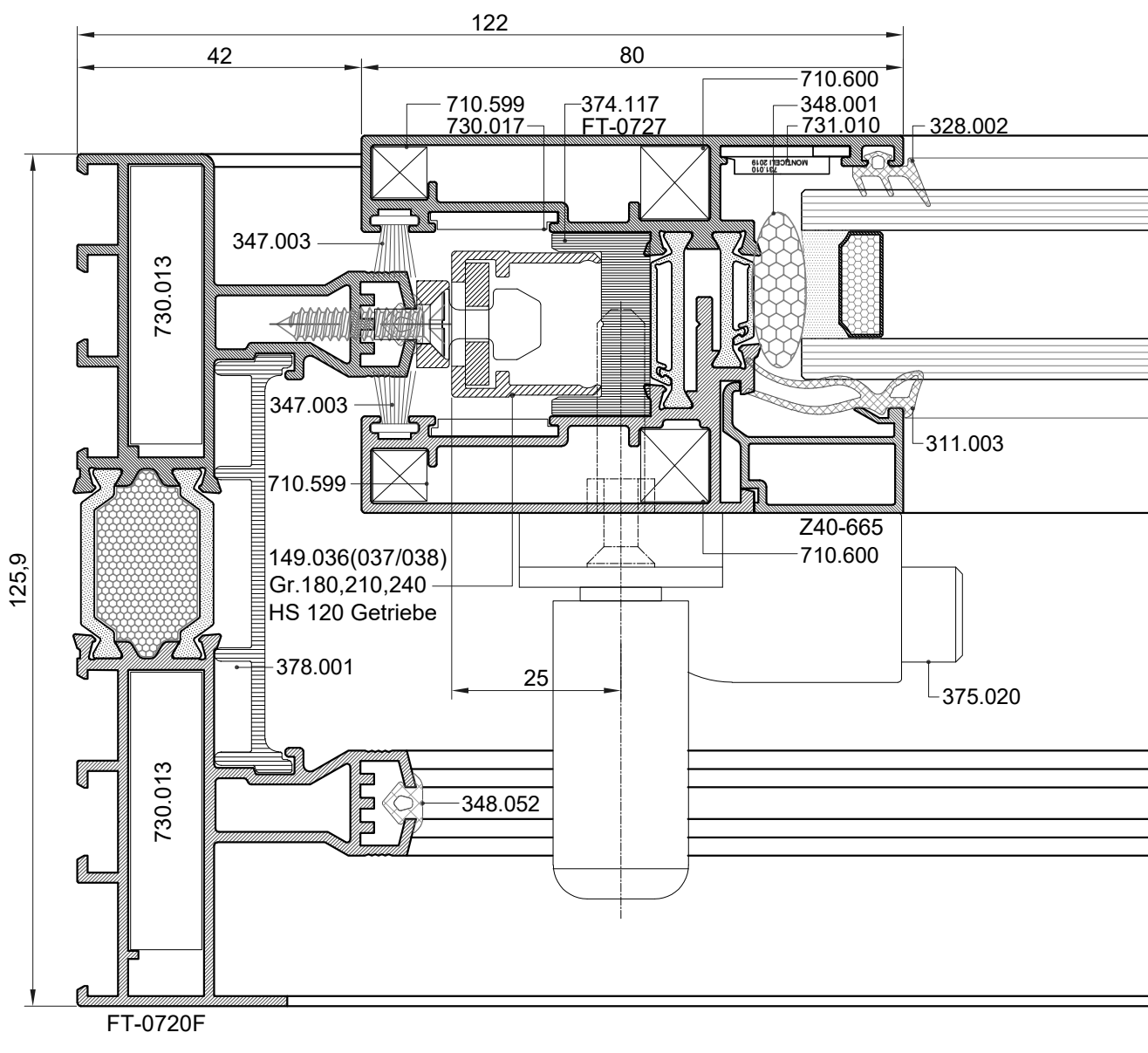
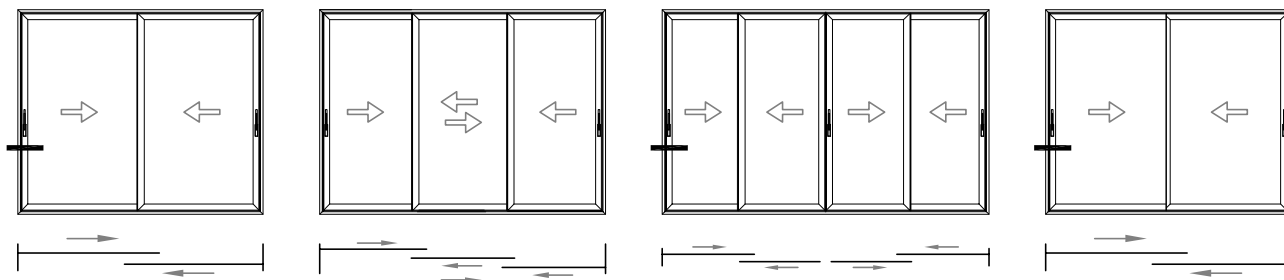

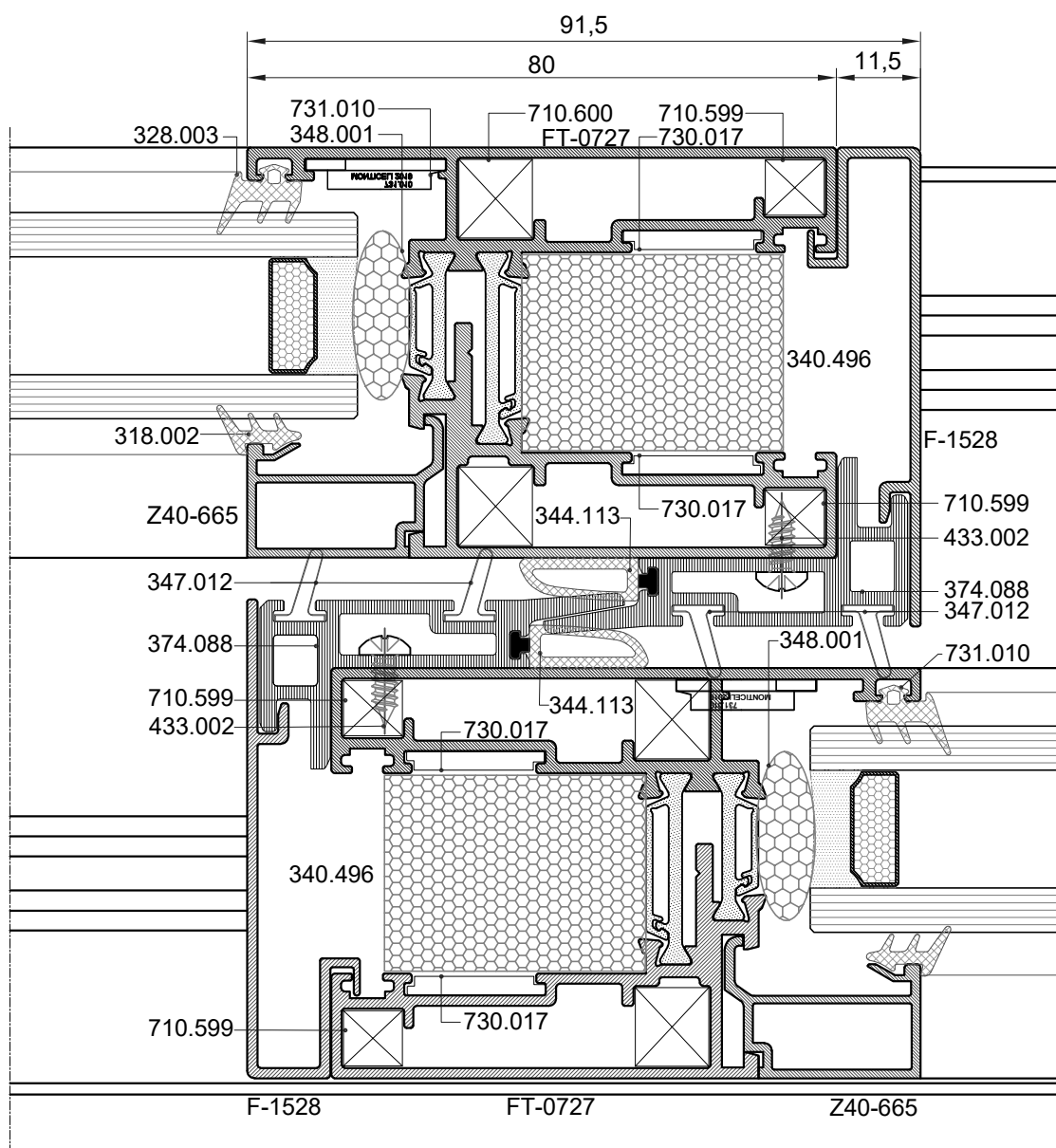
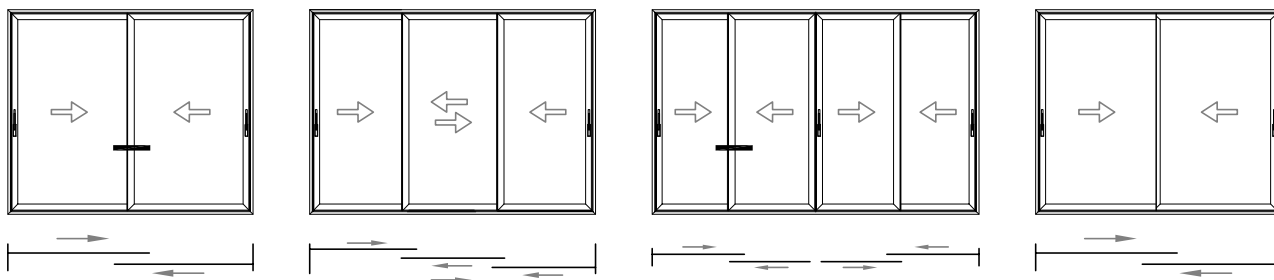

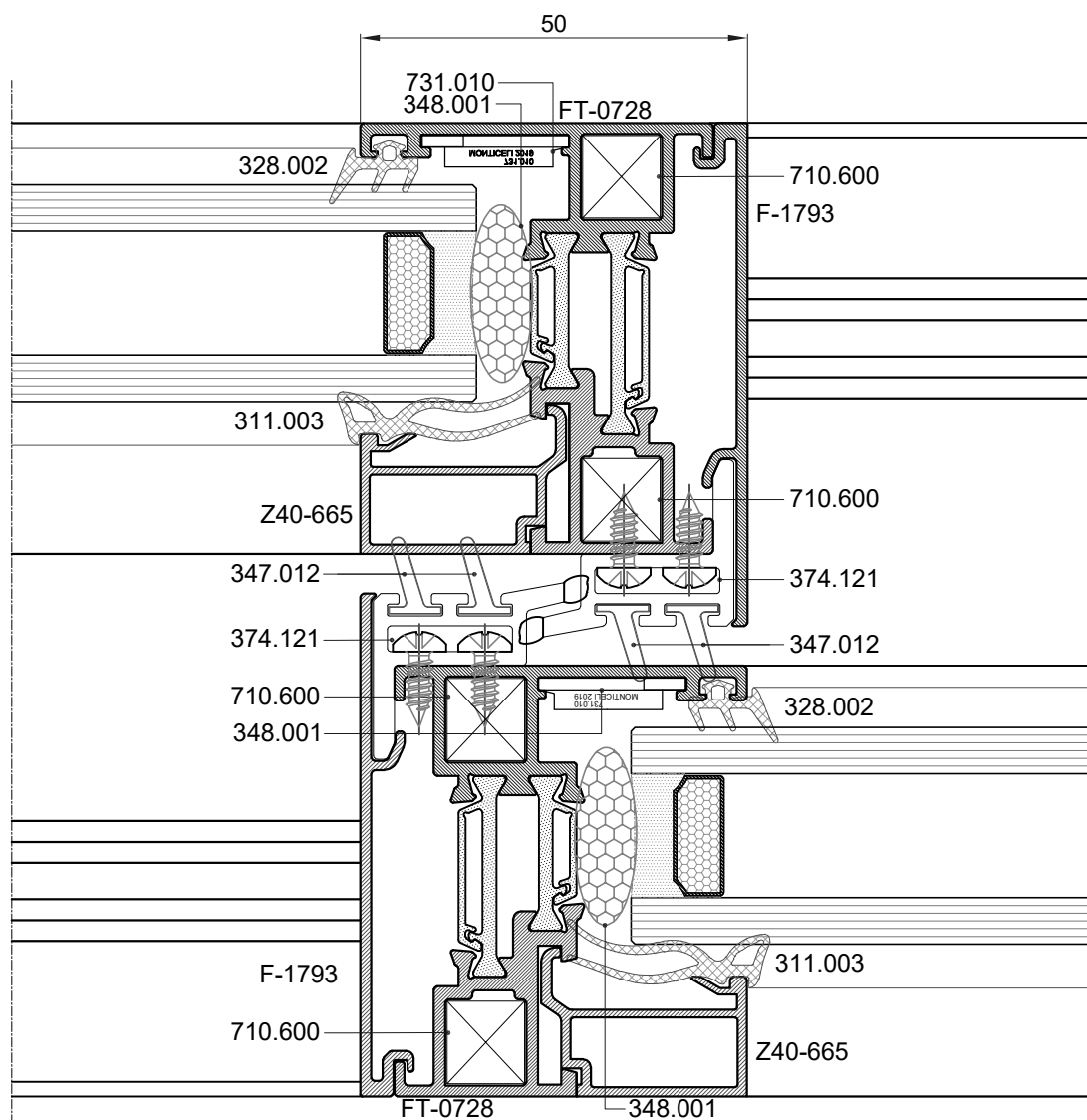
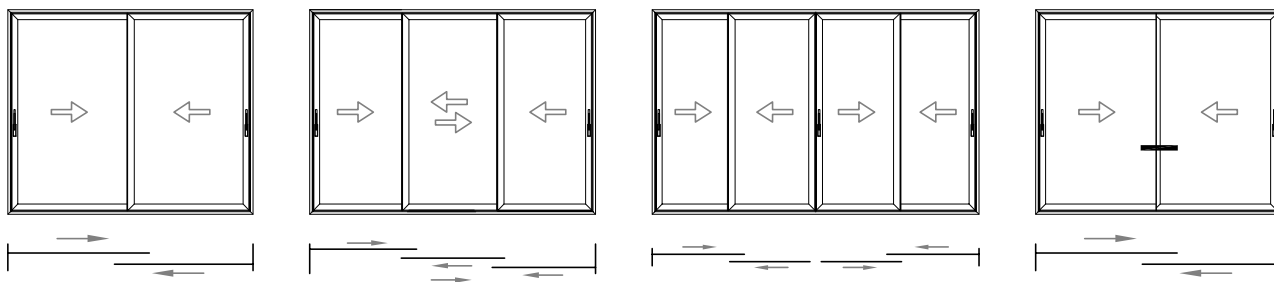

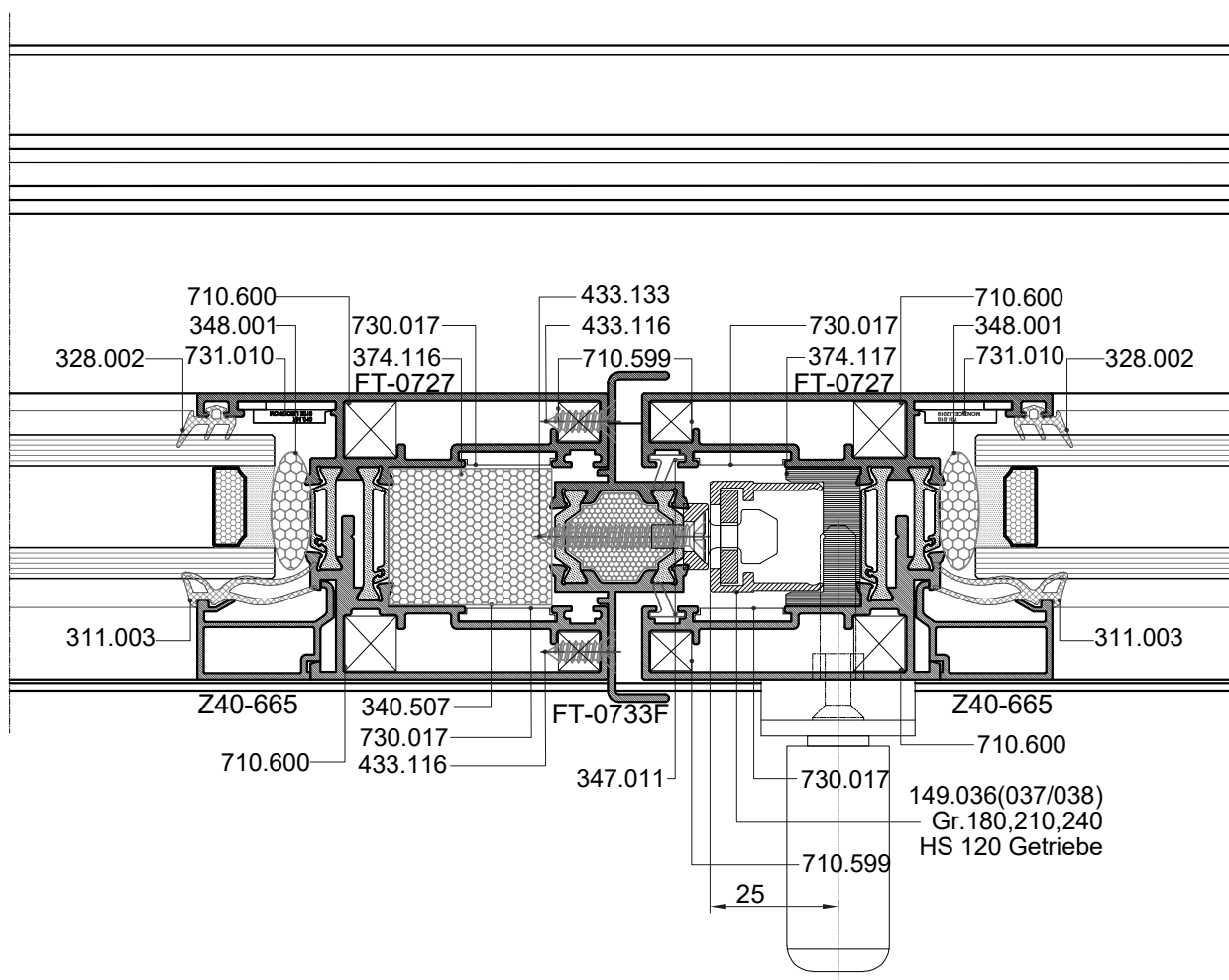
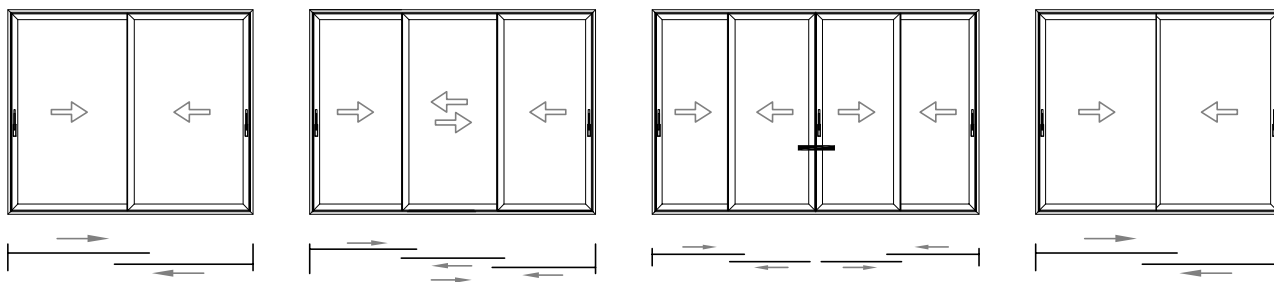

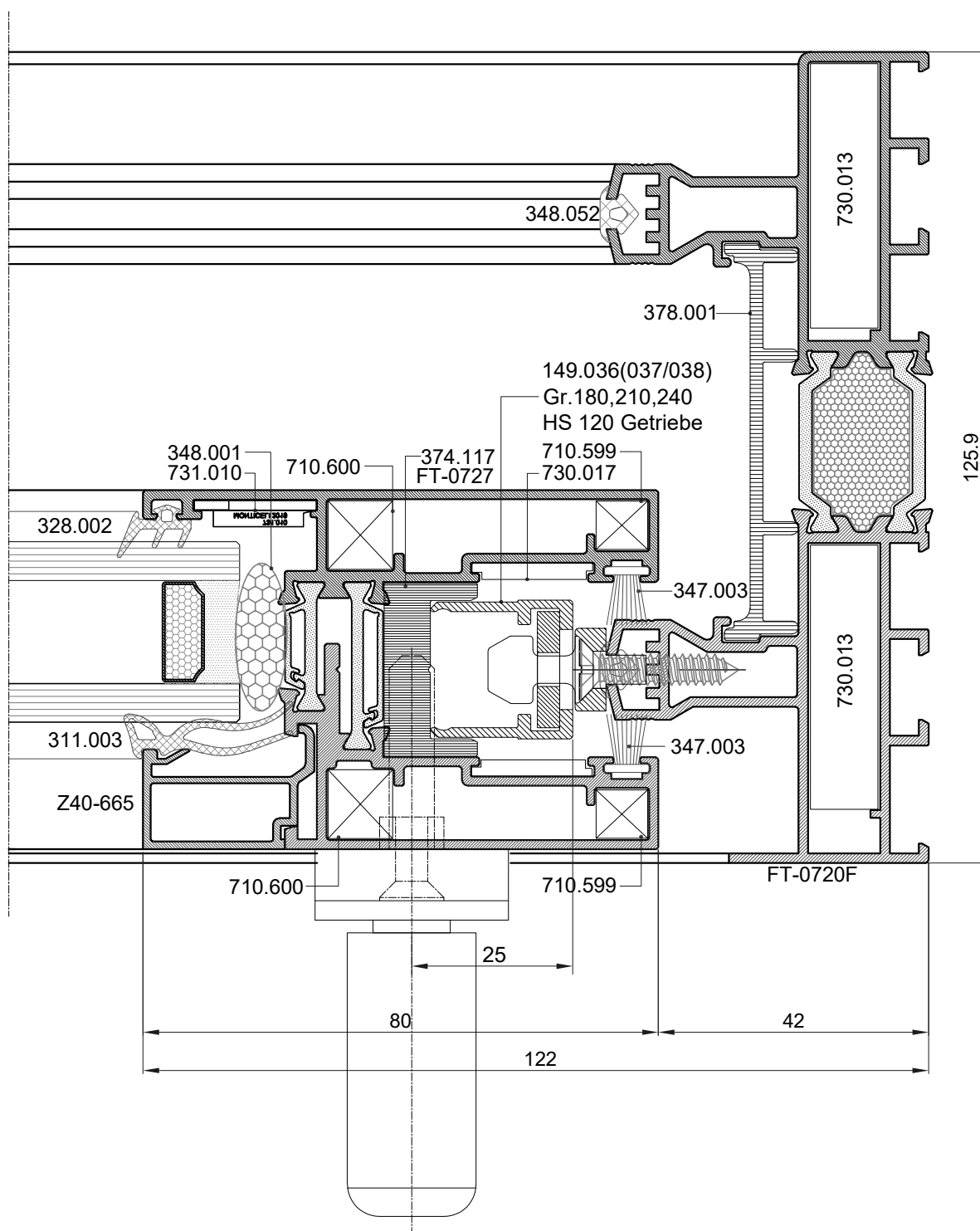
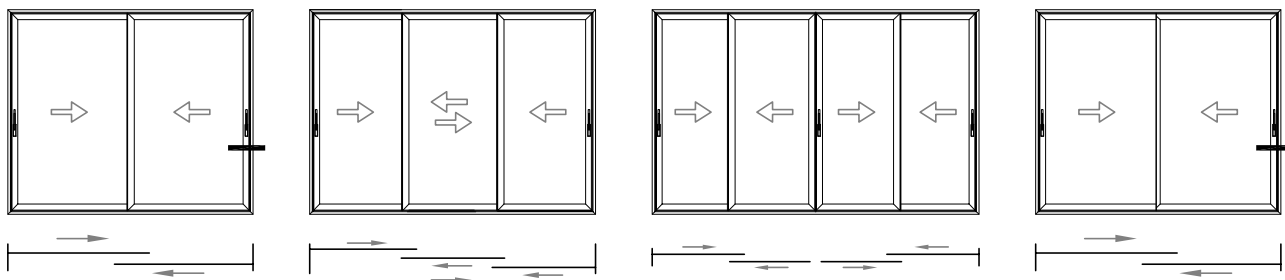

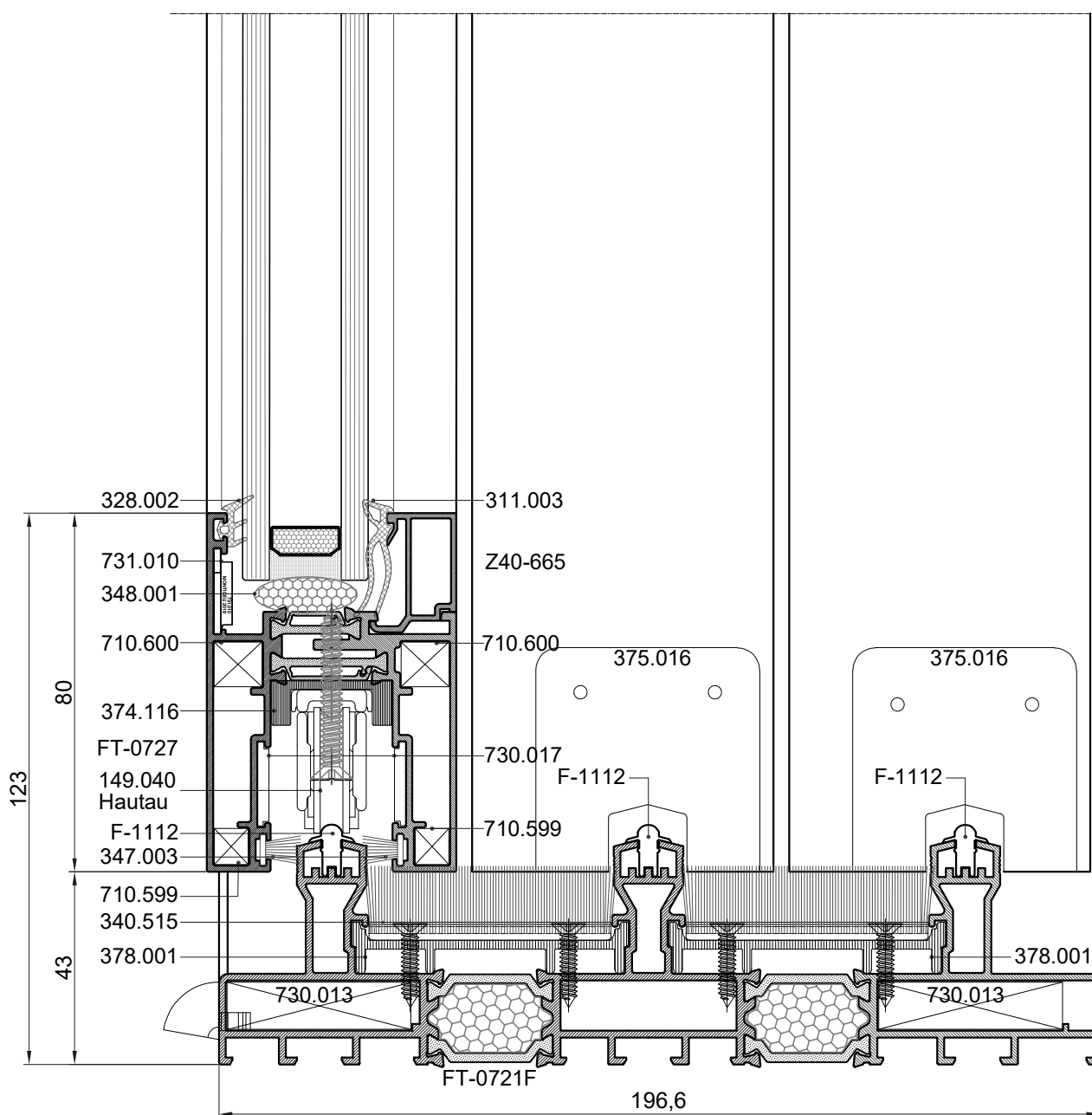
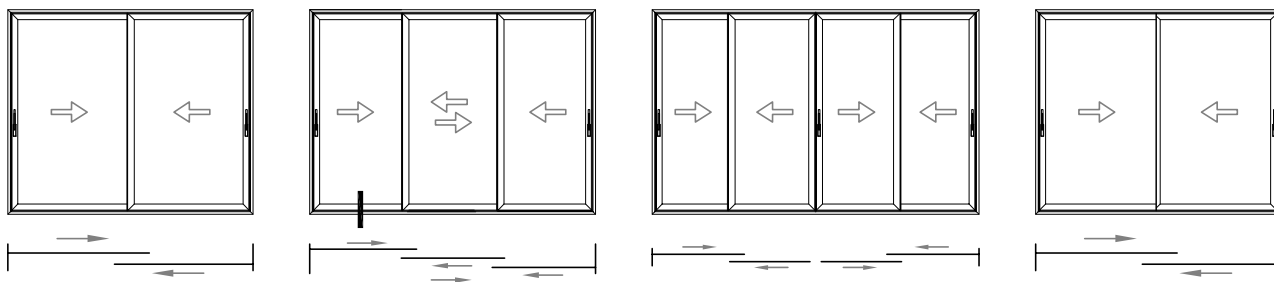

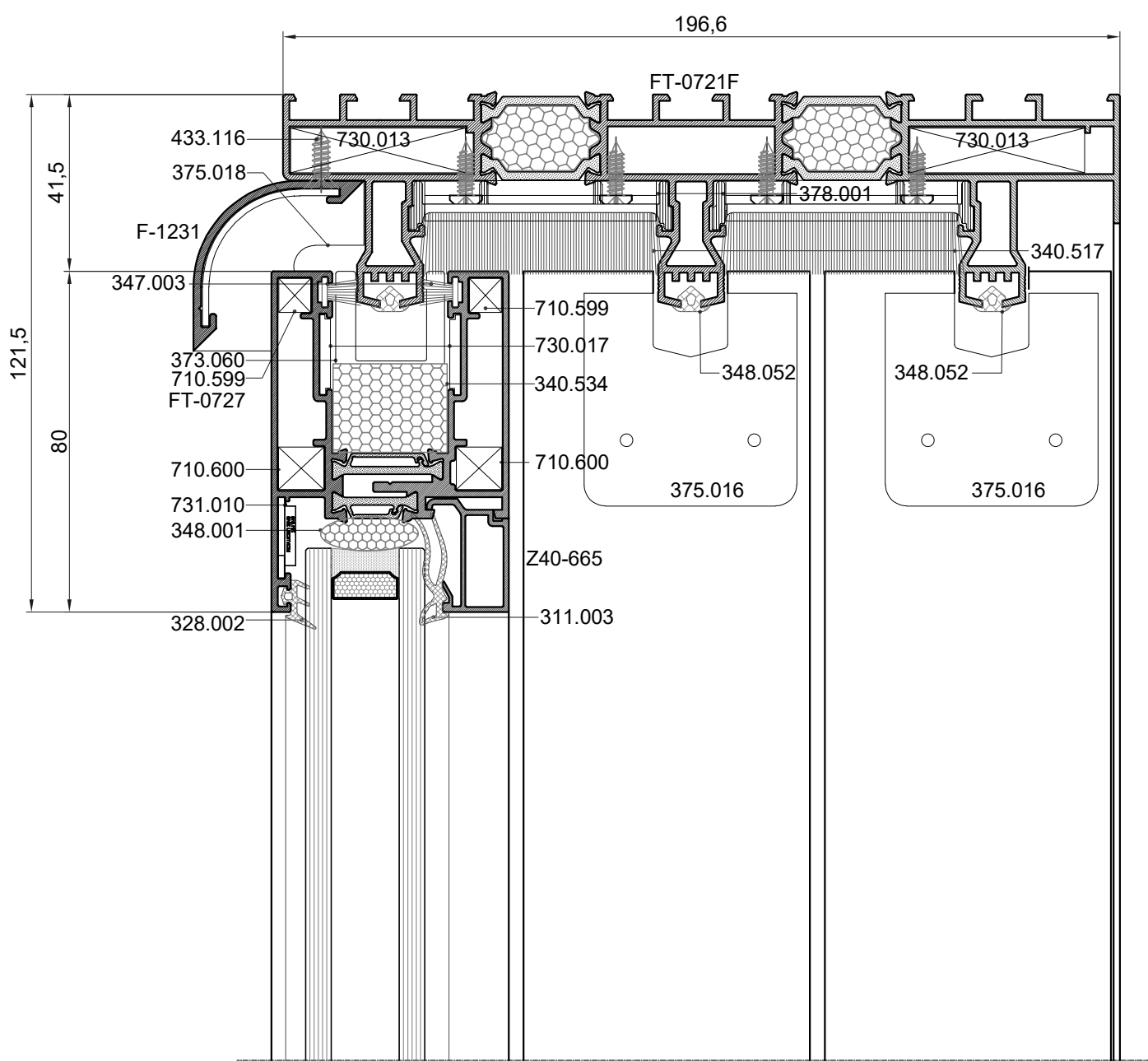
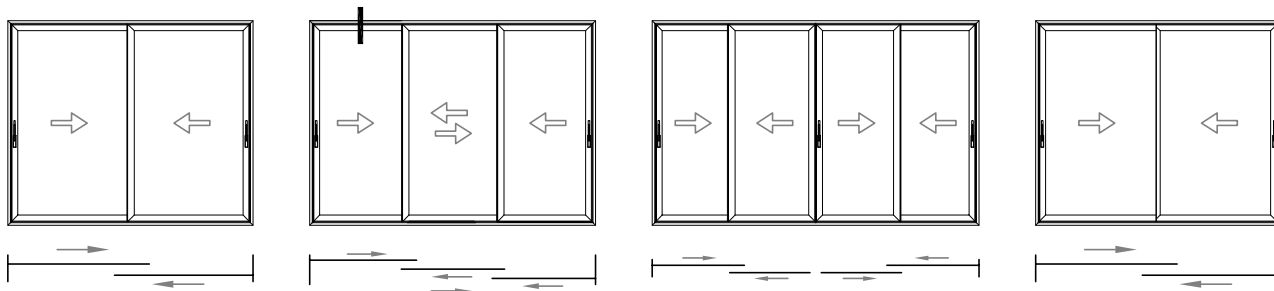

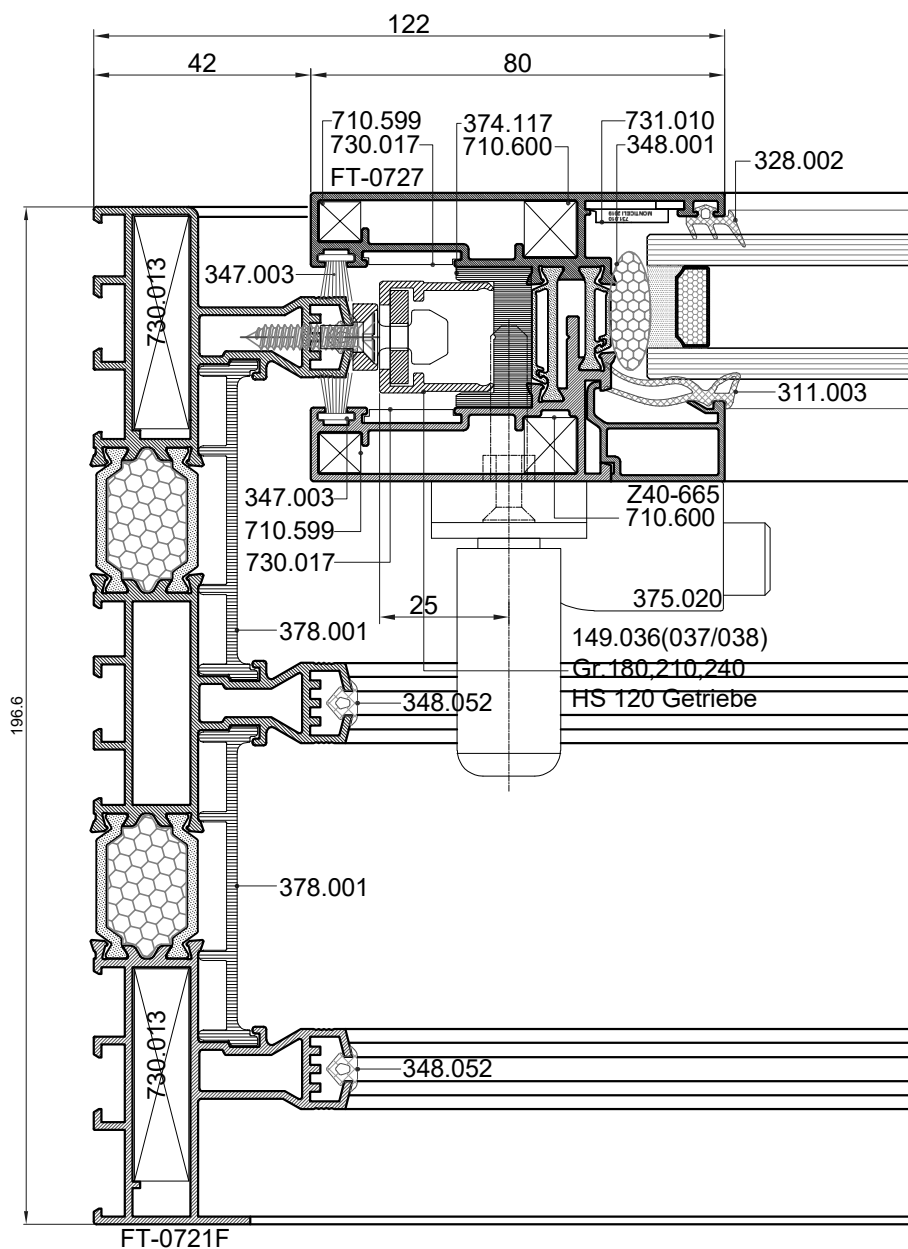
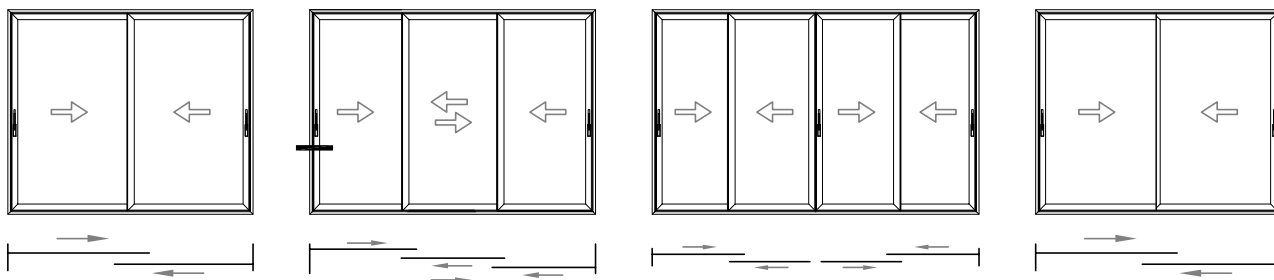

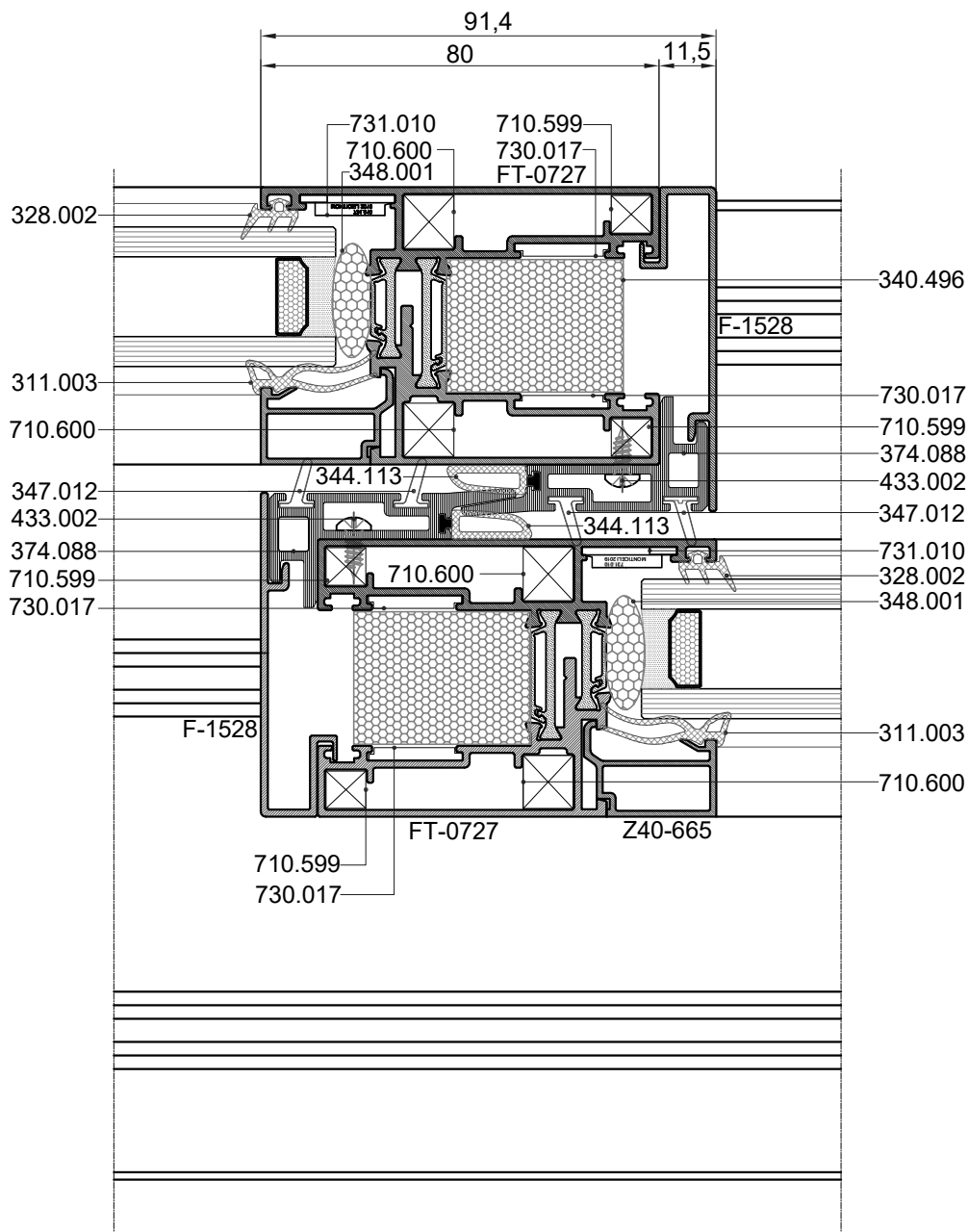
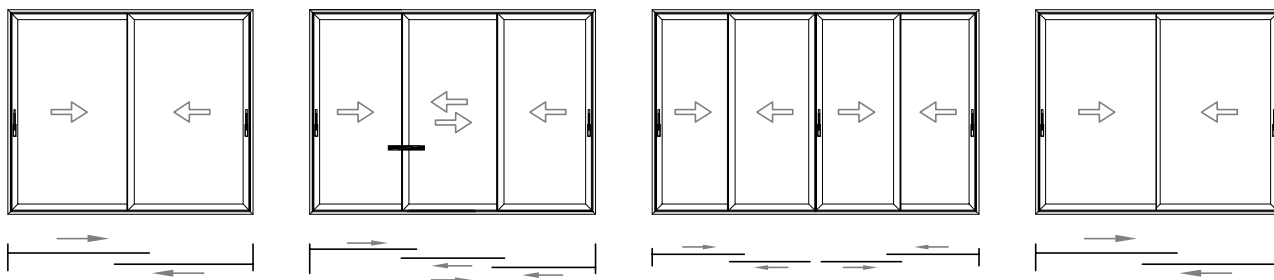

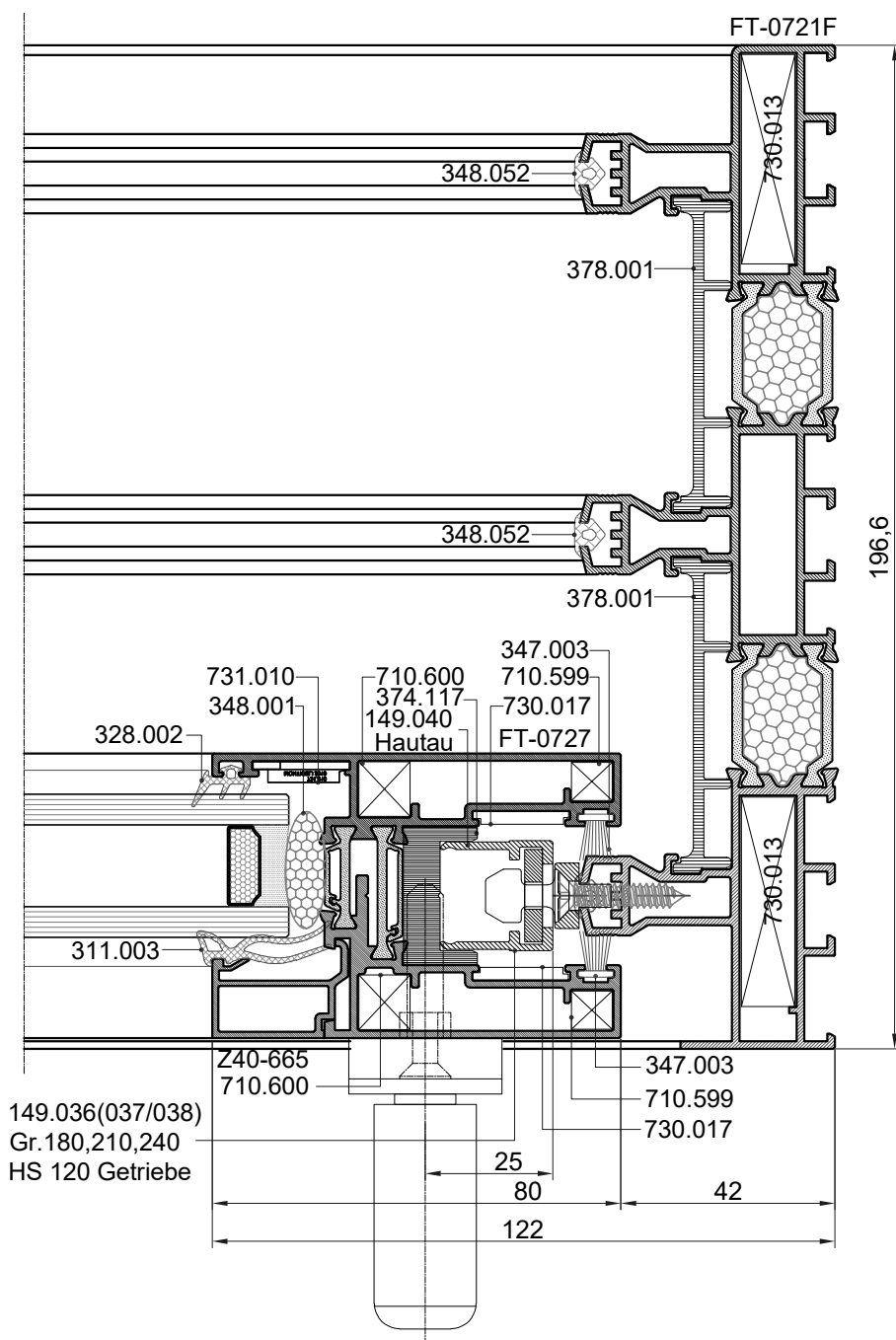
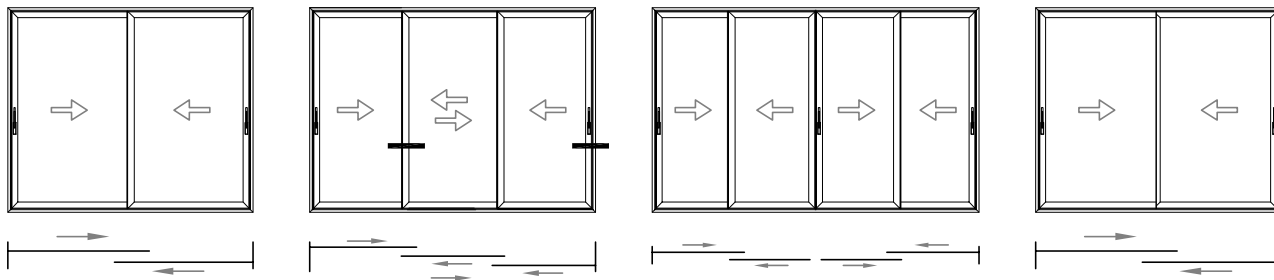

Presjeci s krilom FT-0725 podizno-klizno

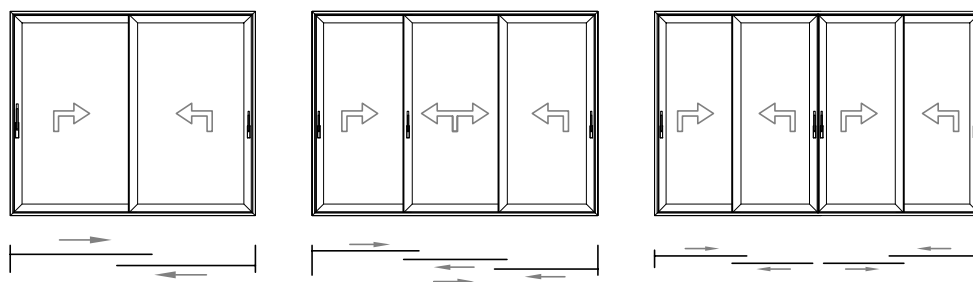

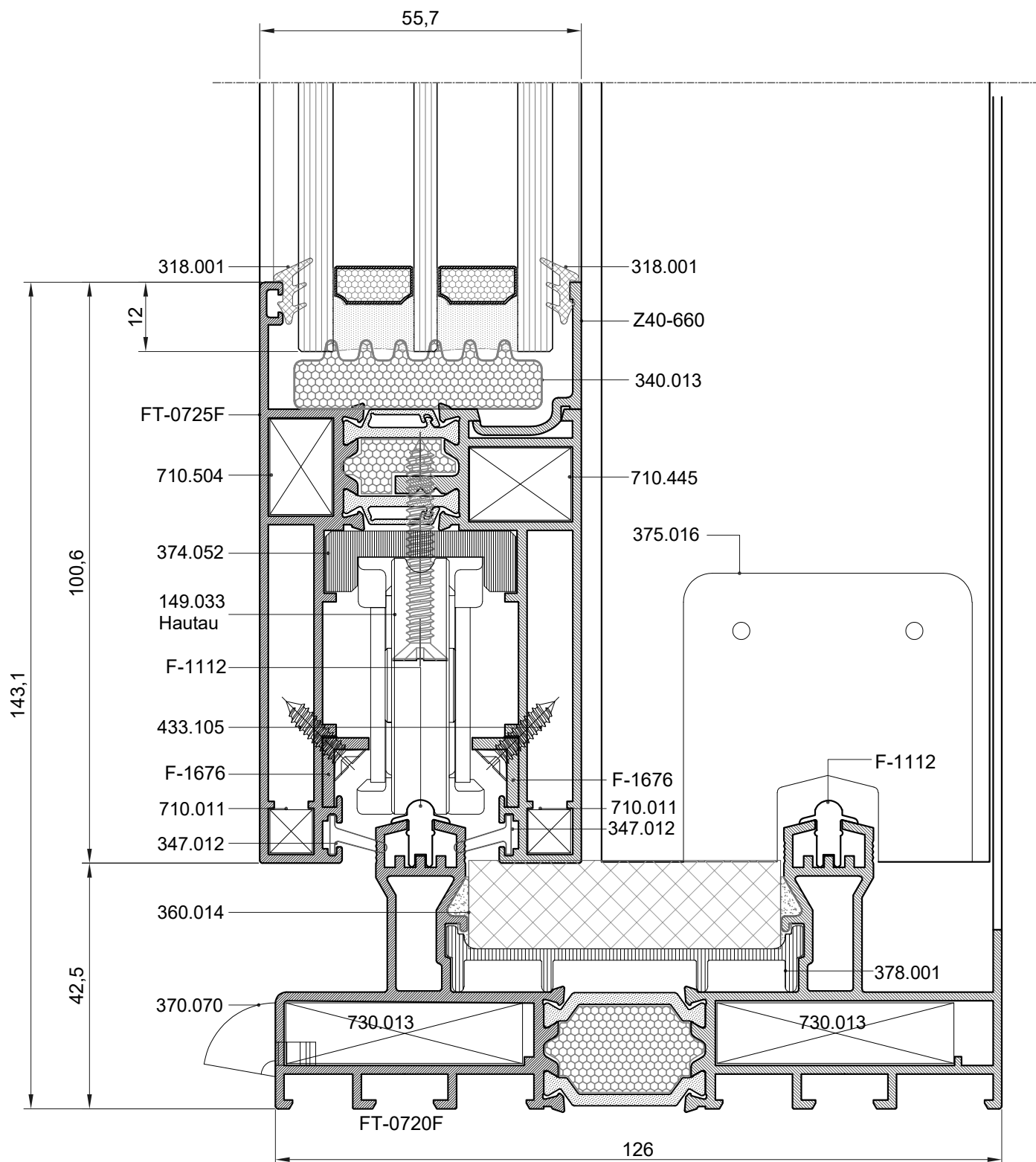
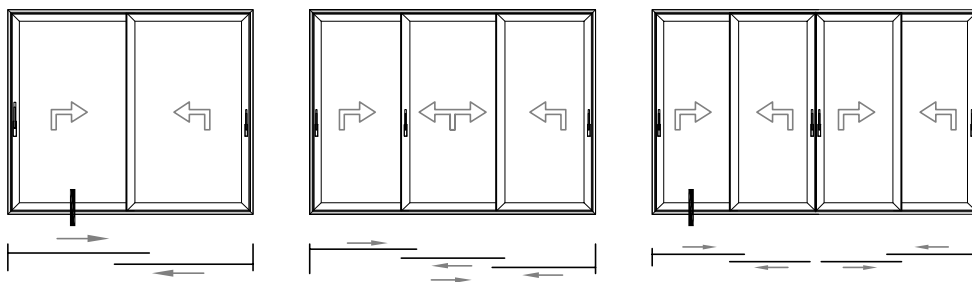

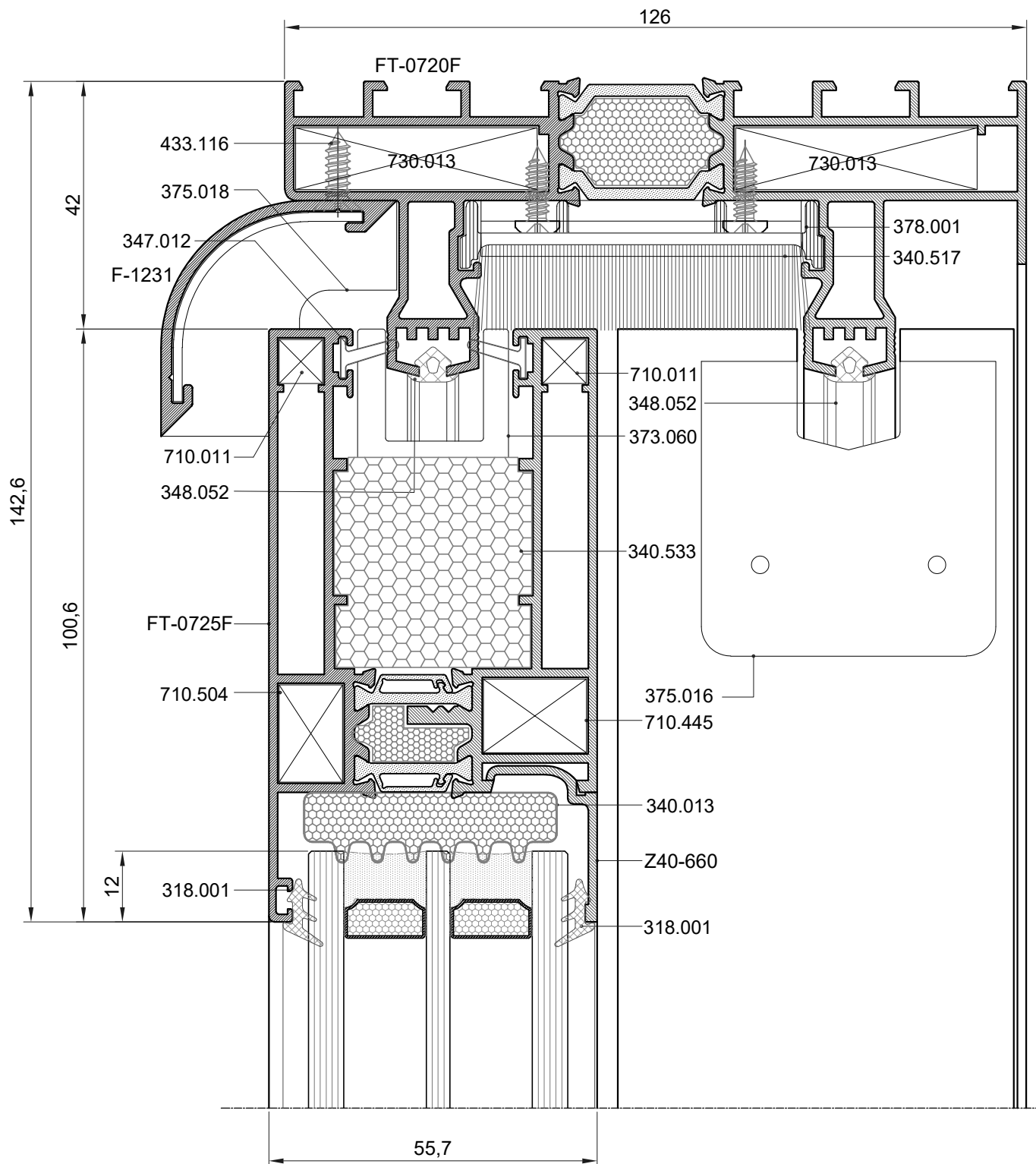
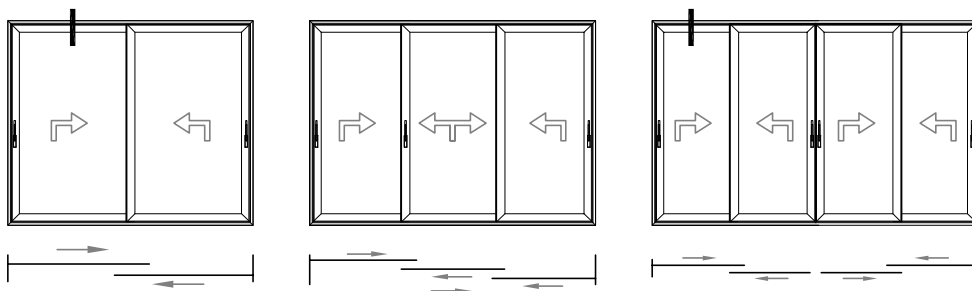

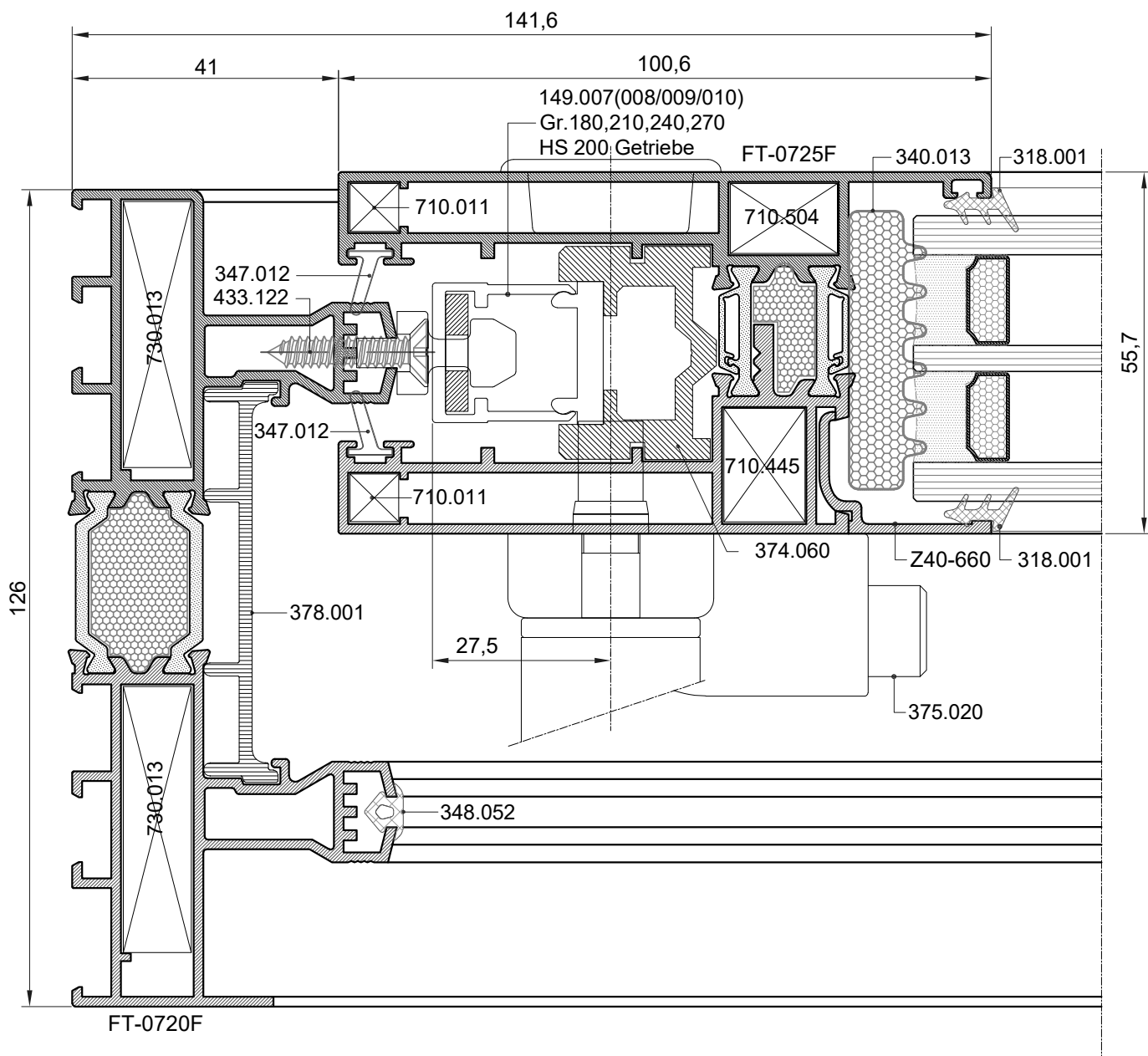
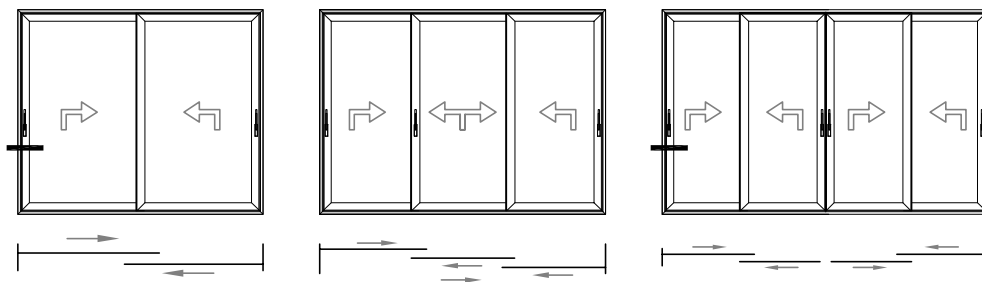

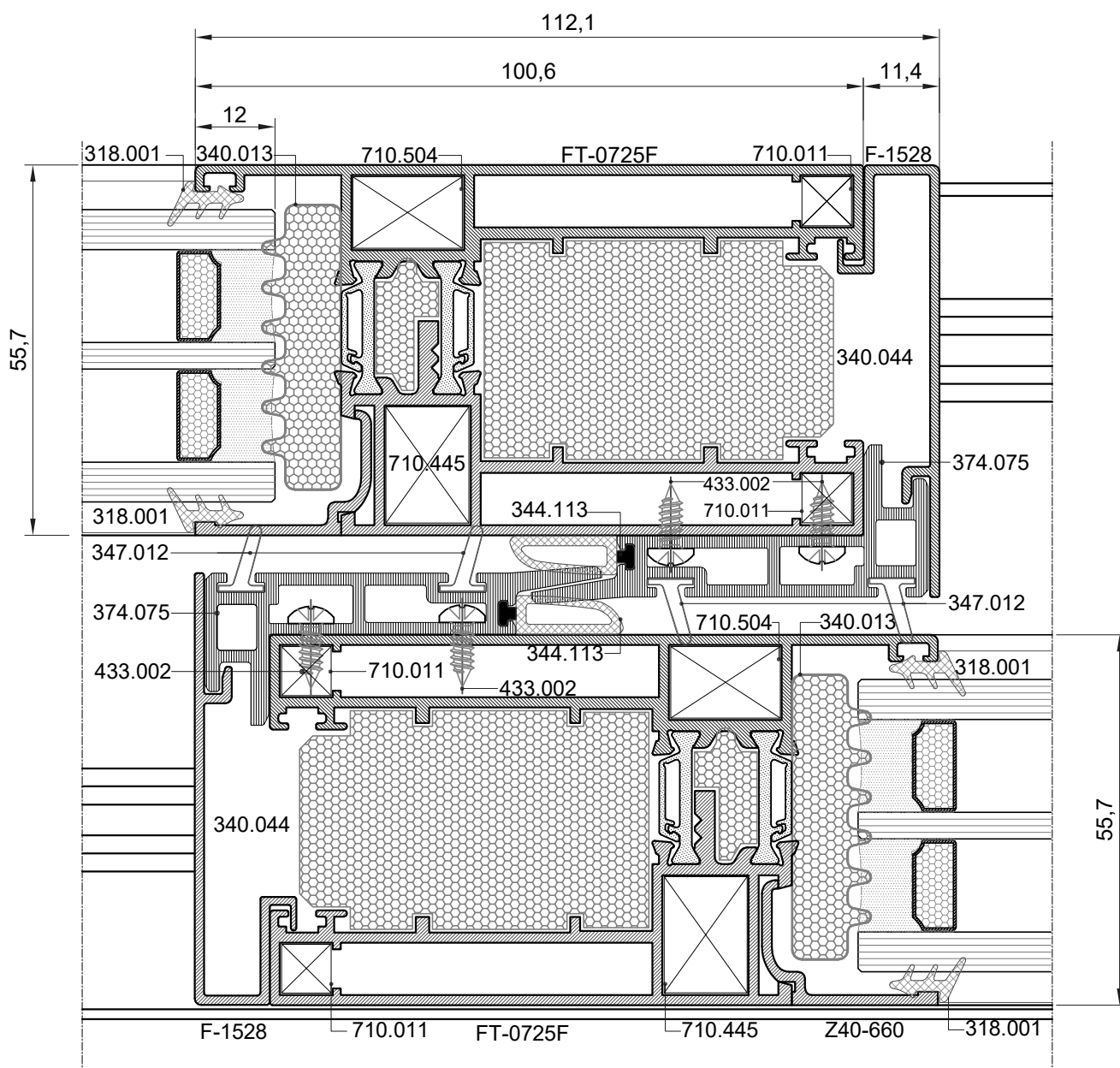
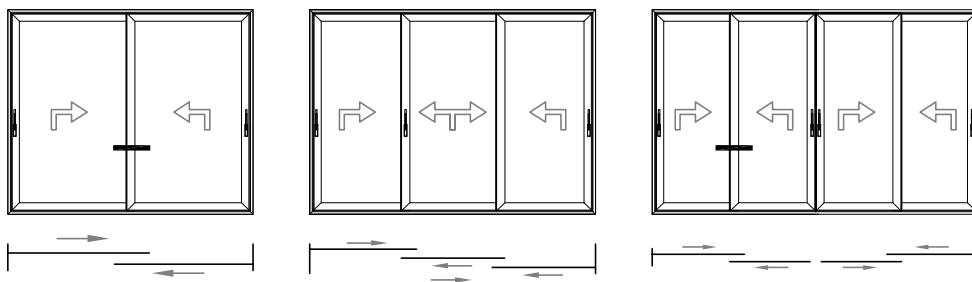

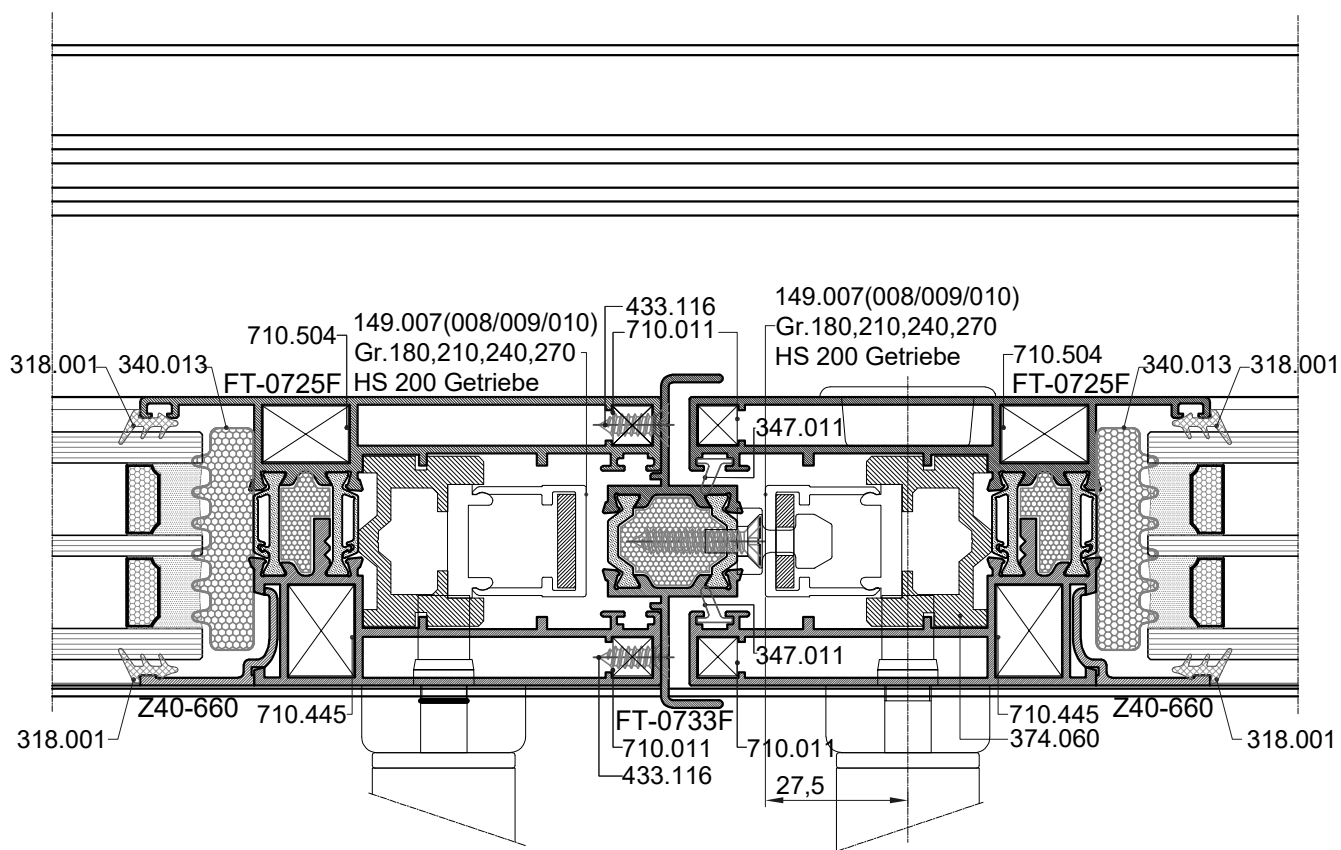
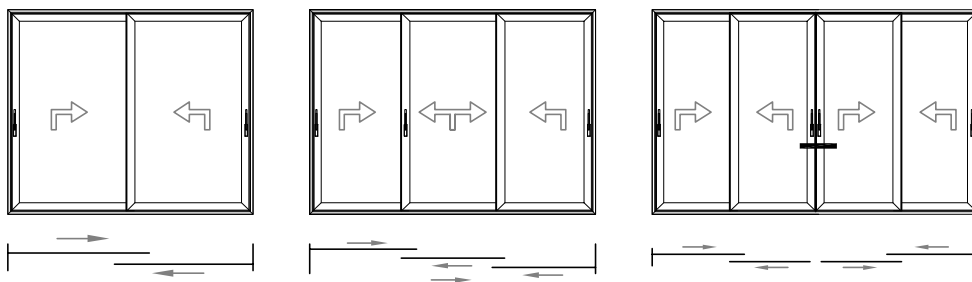

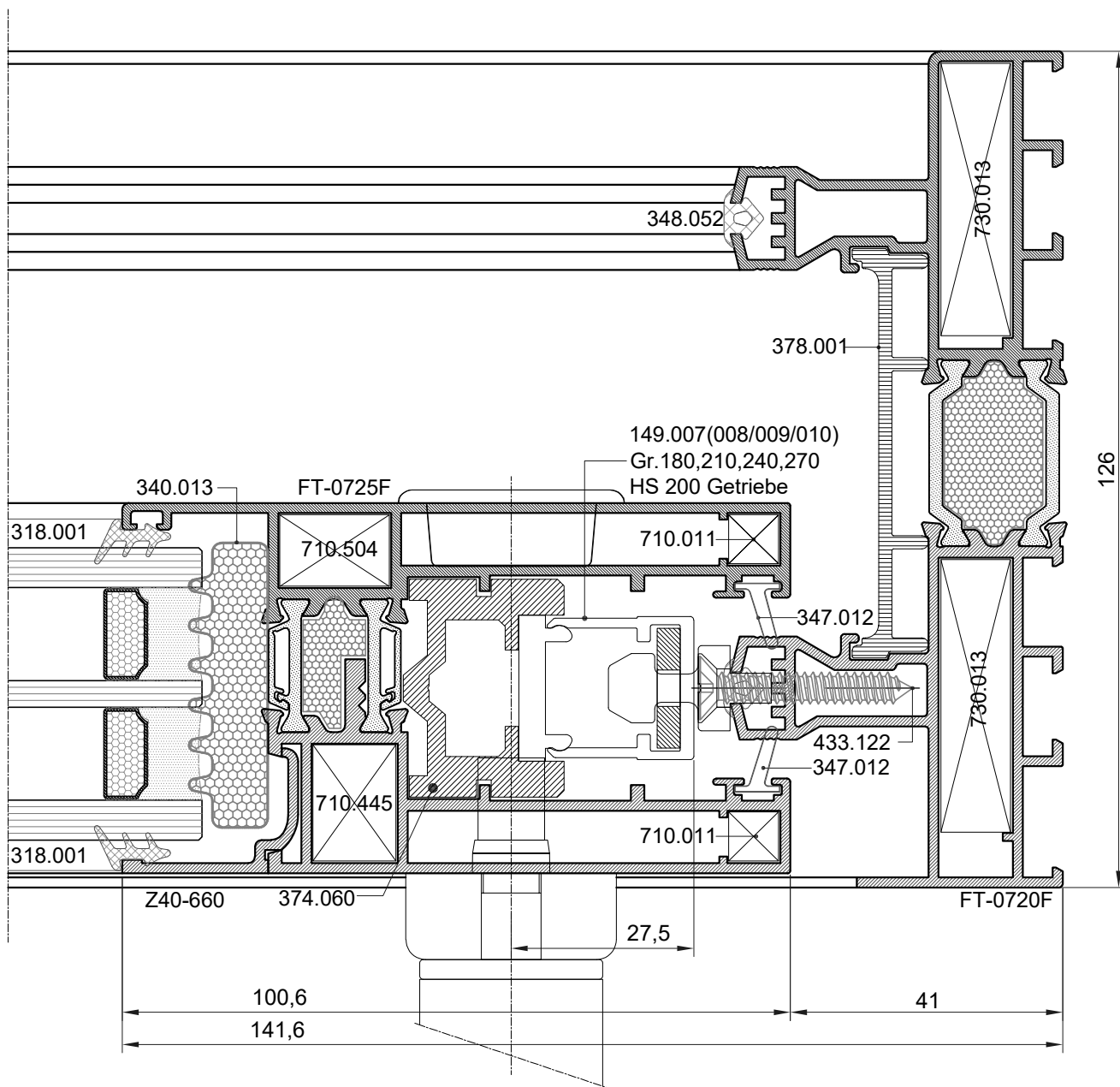
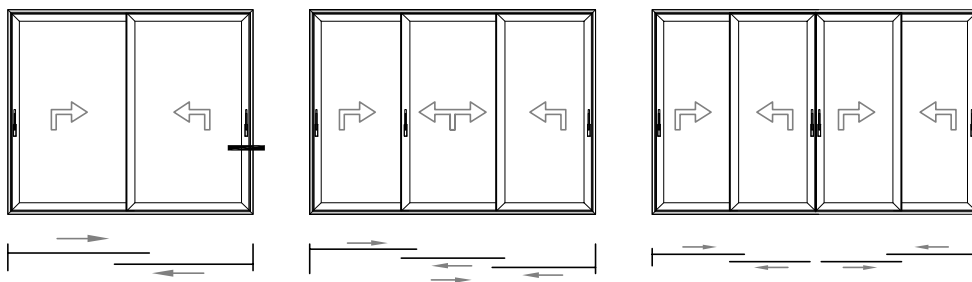

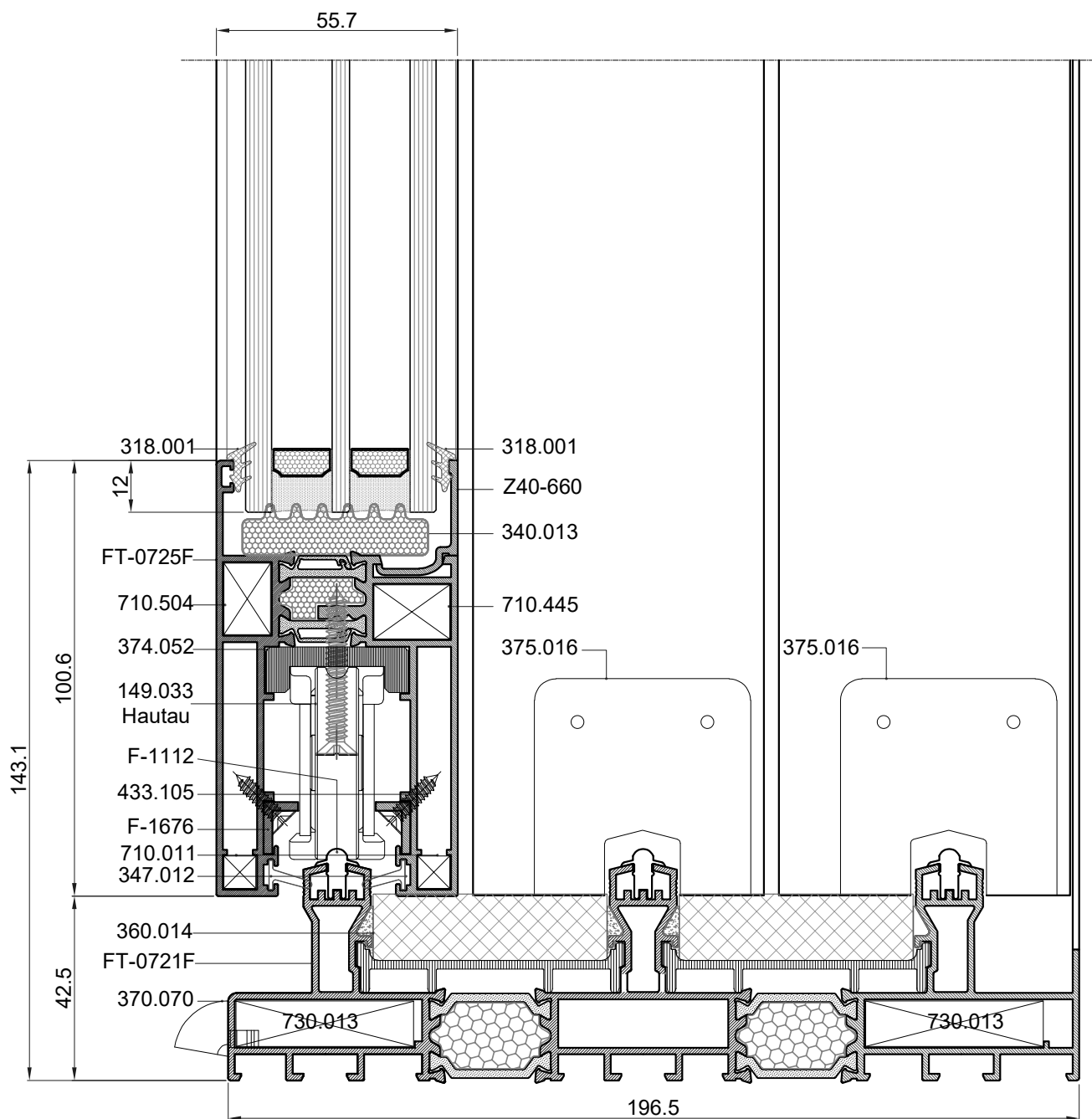
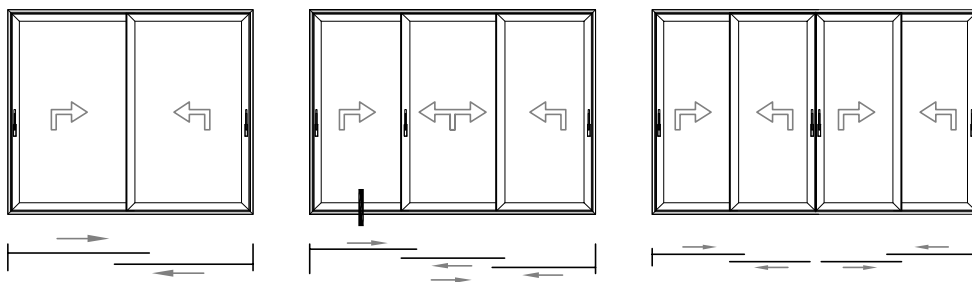

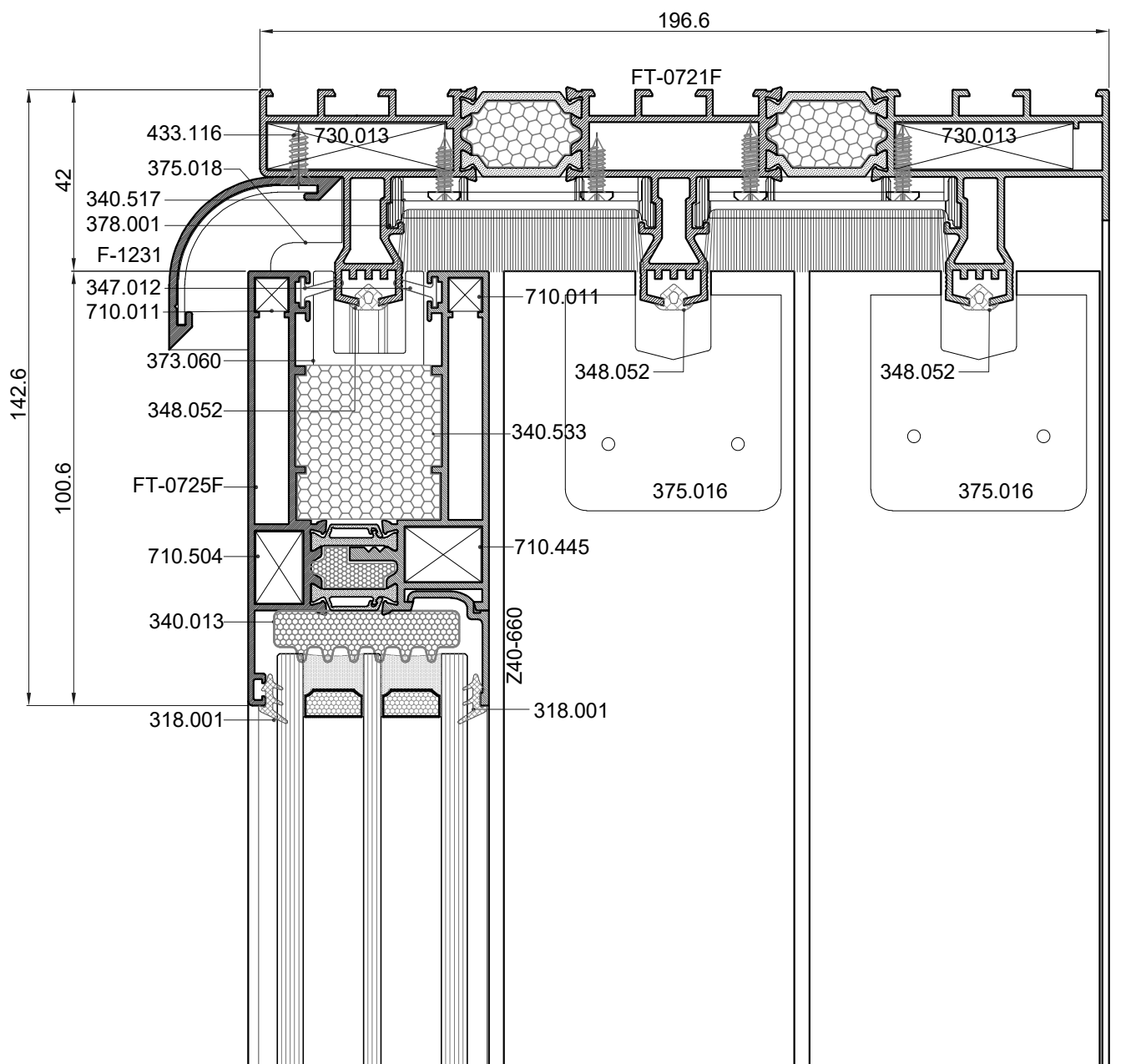
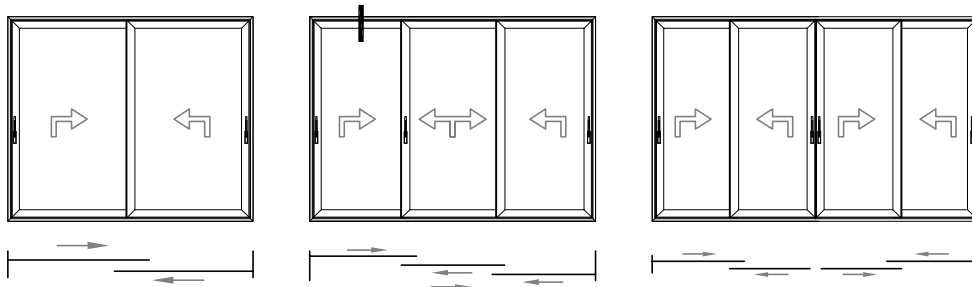

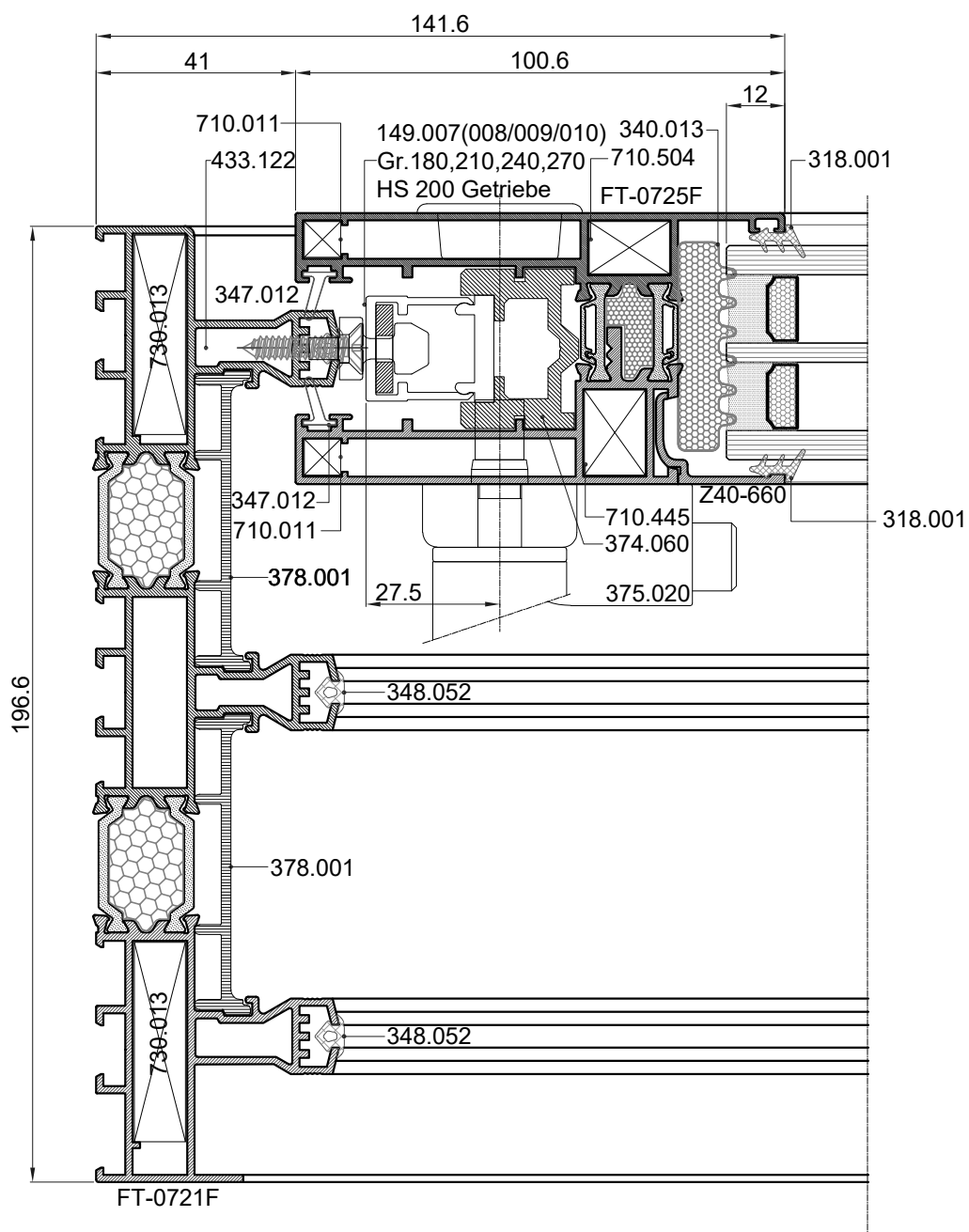
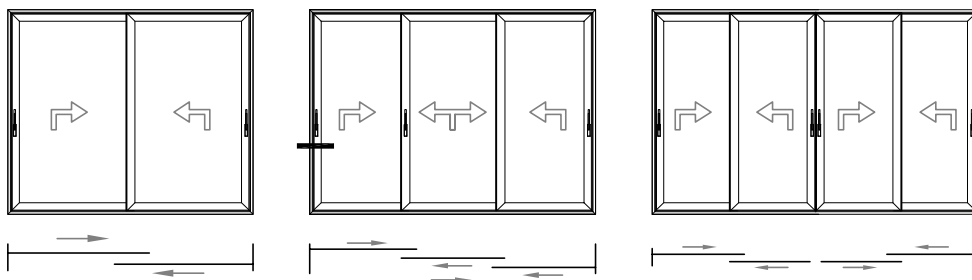

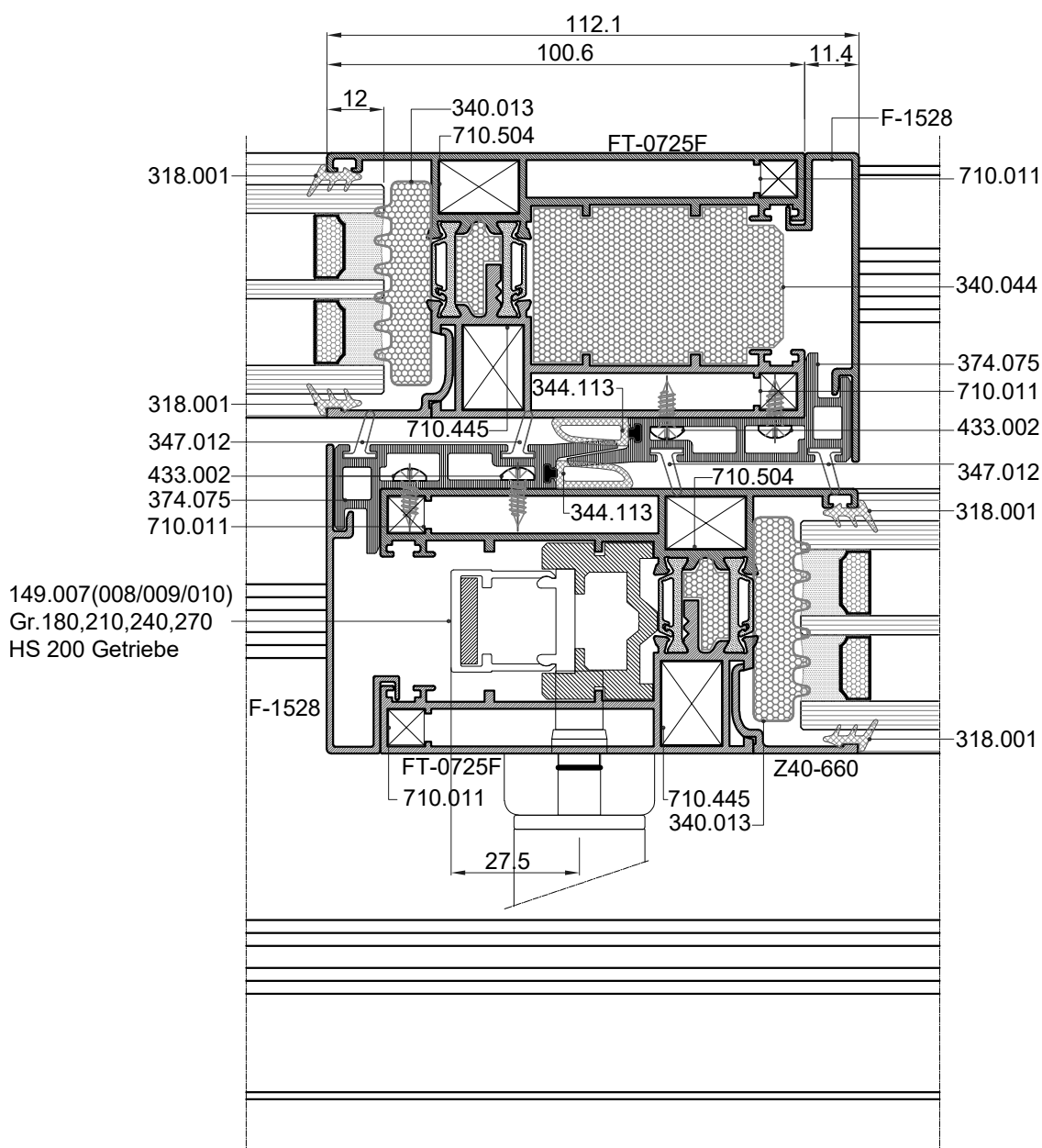
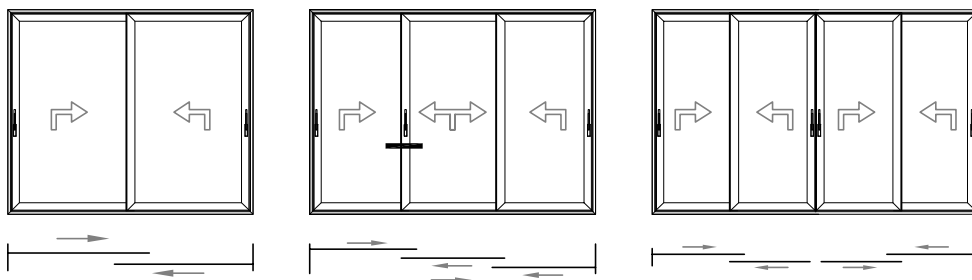

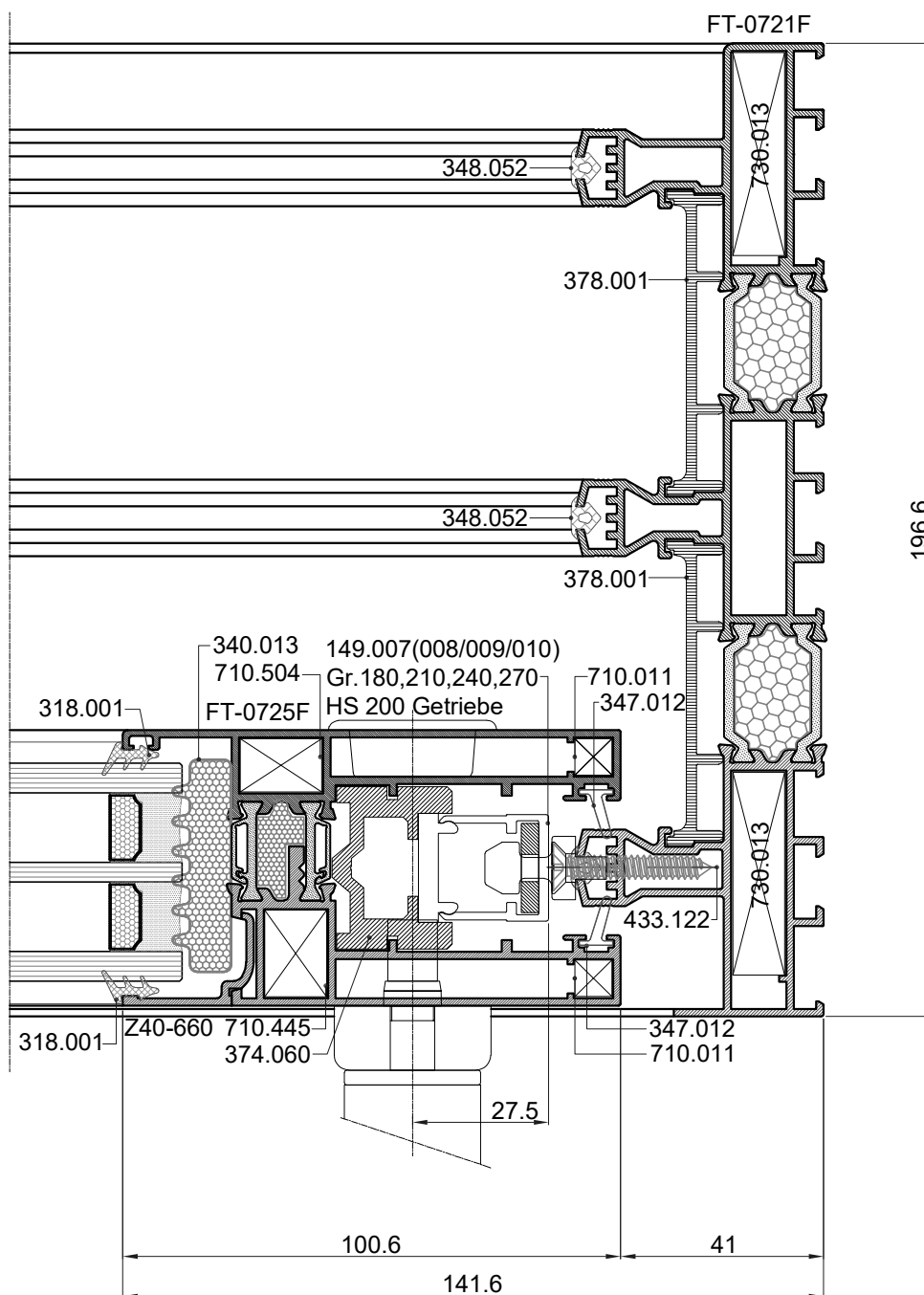
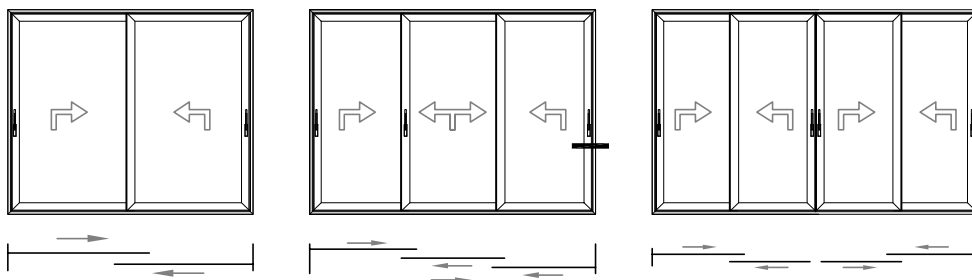

Presjeci s krilom FT-0727 podizno-klizno

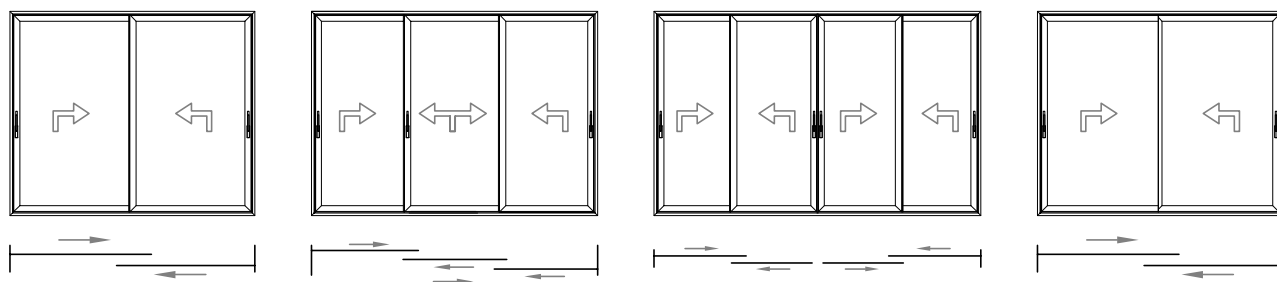

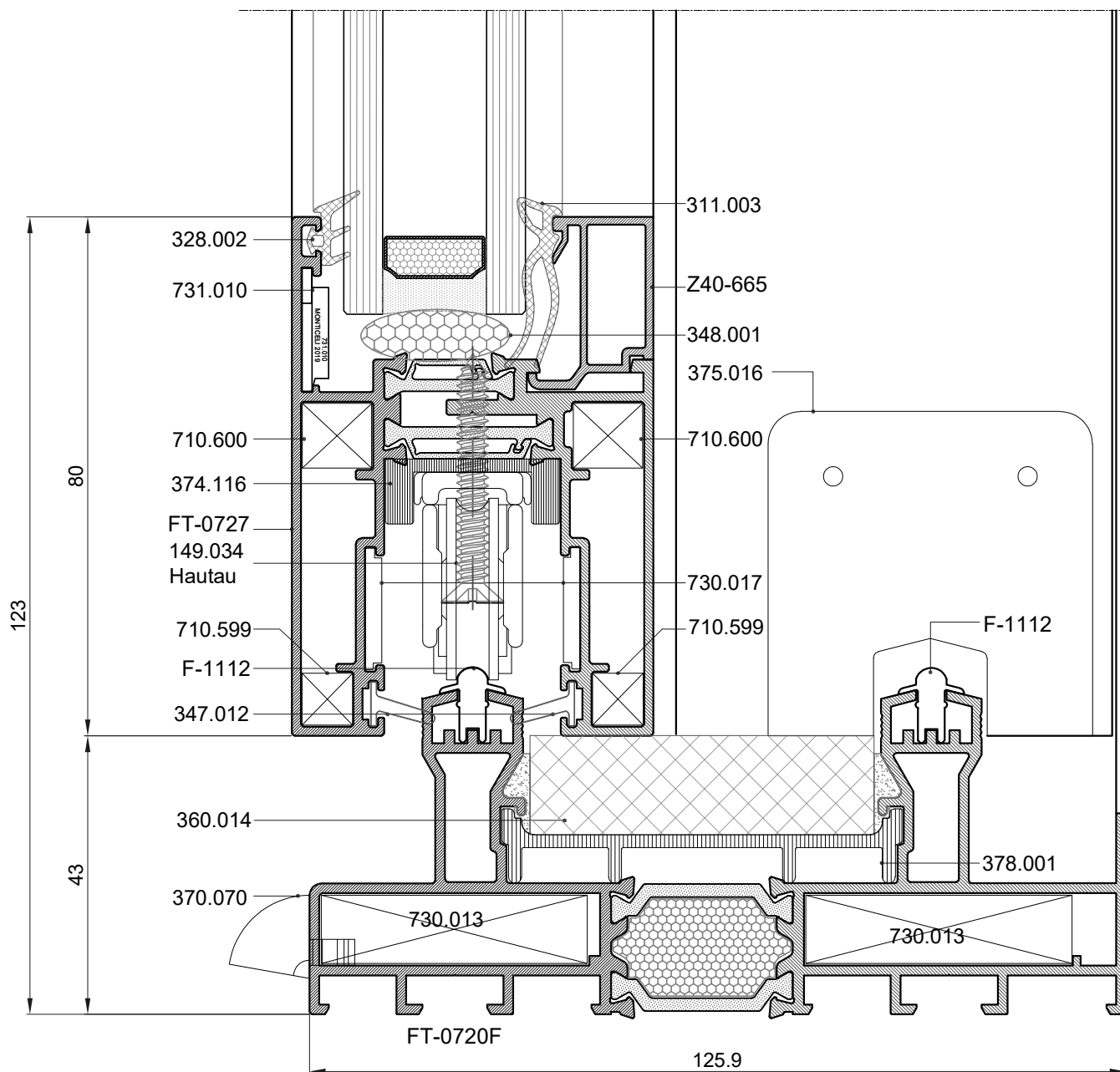
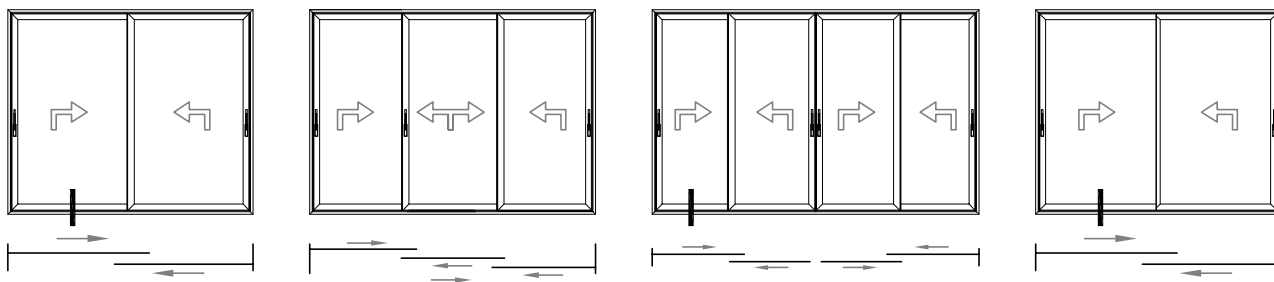

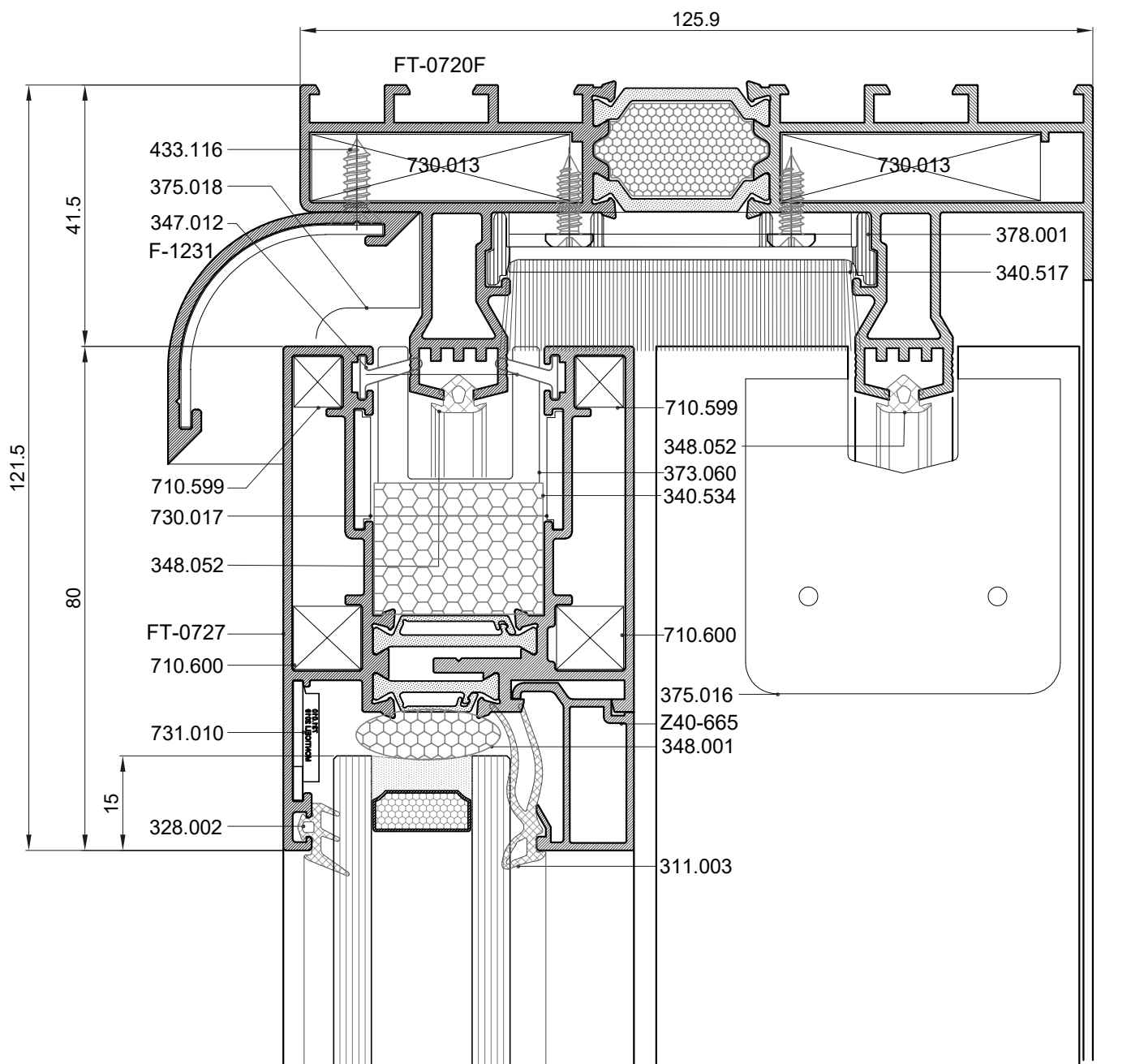
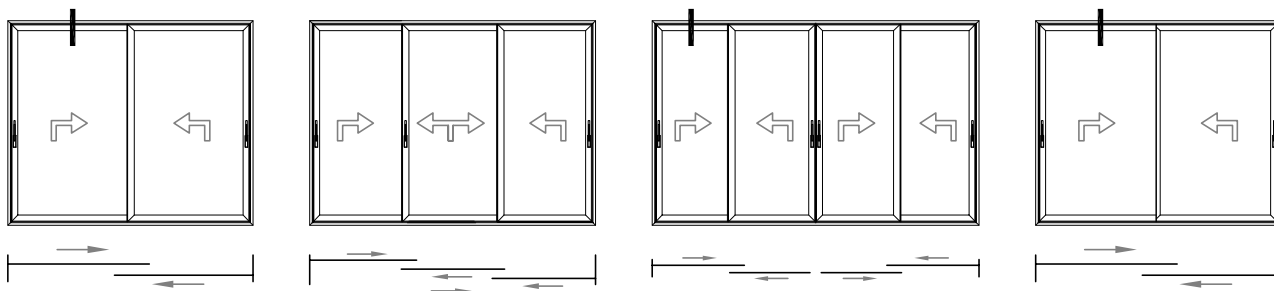

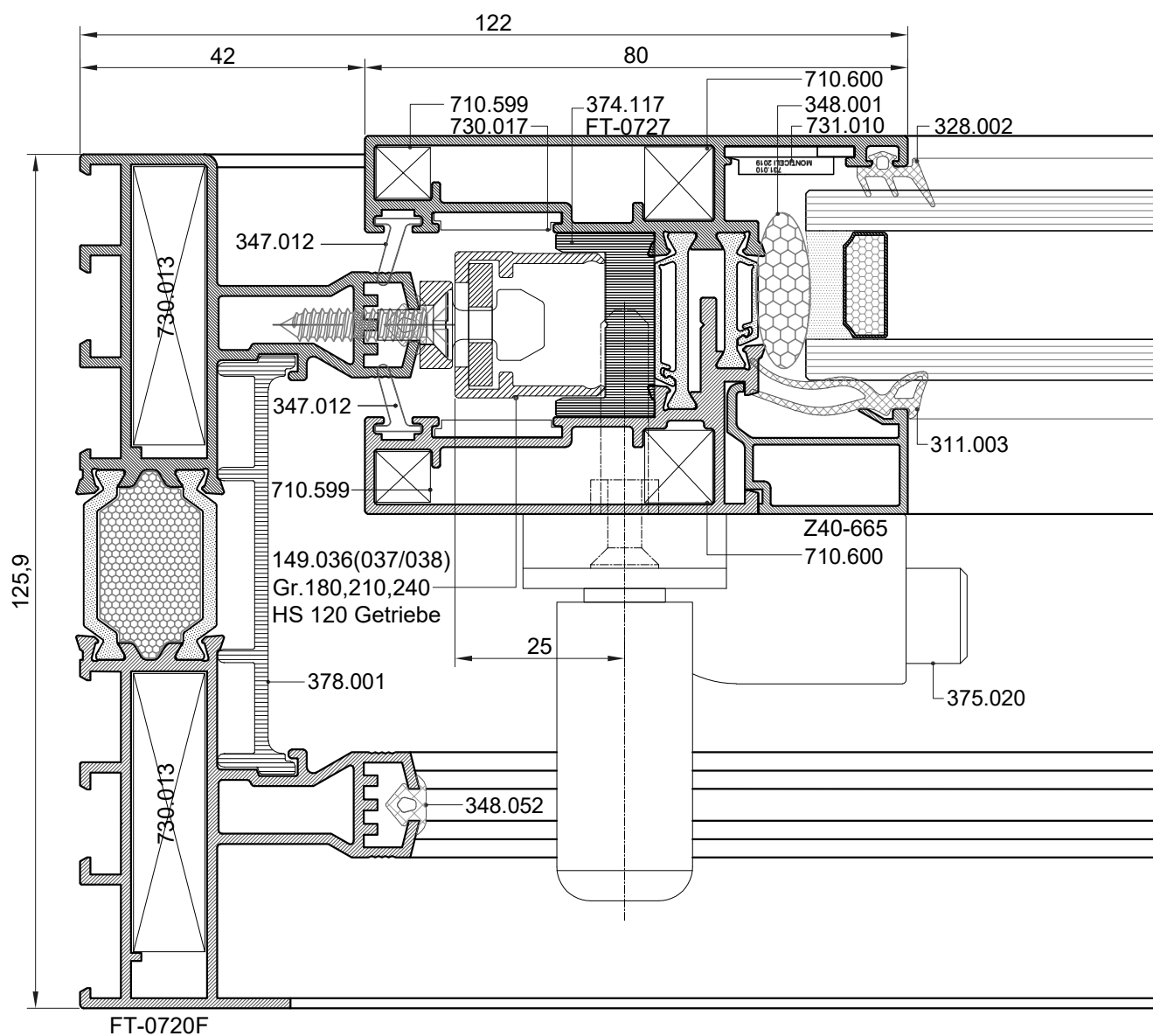
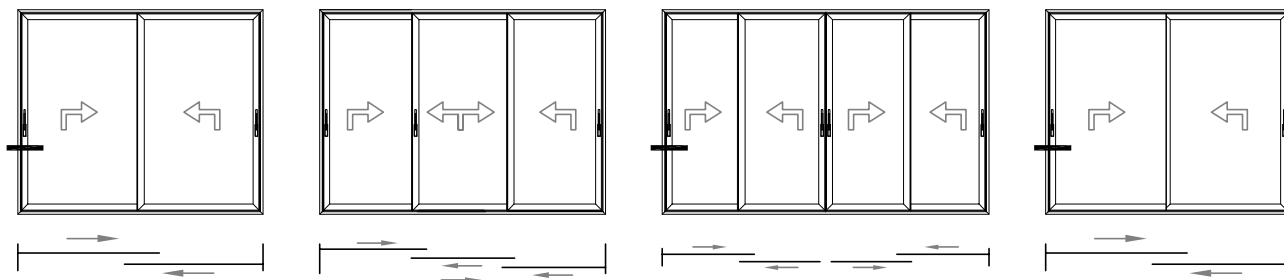

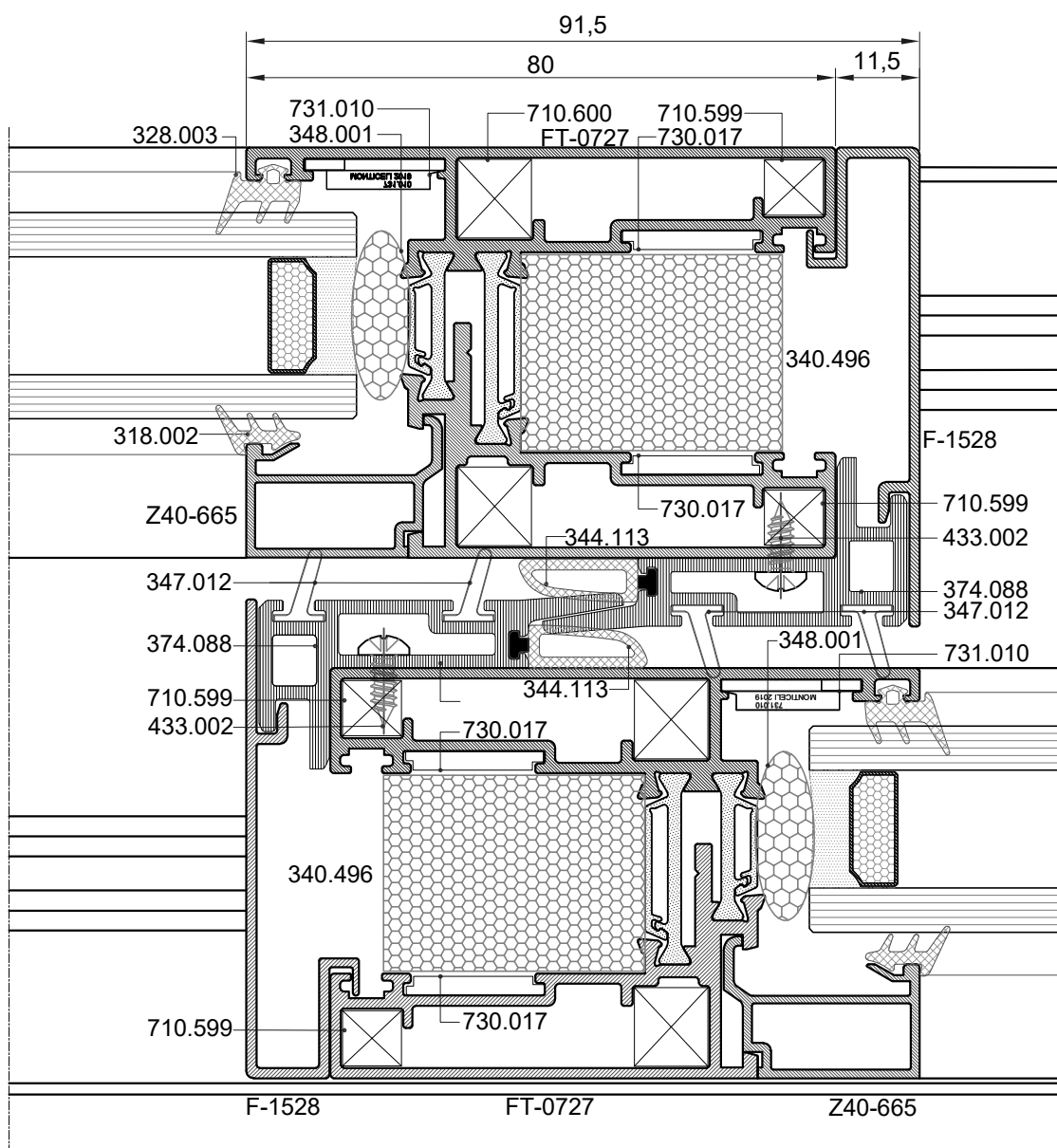
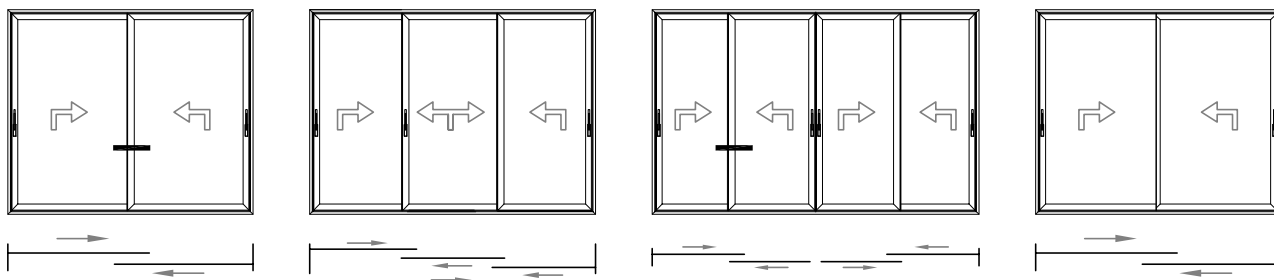

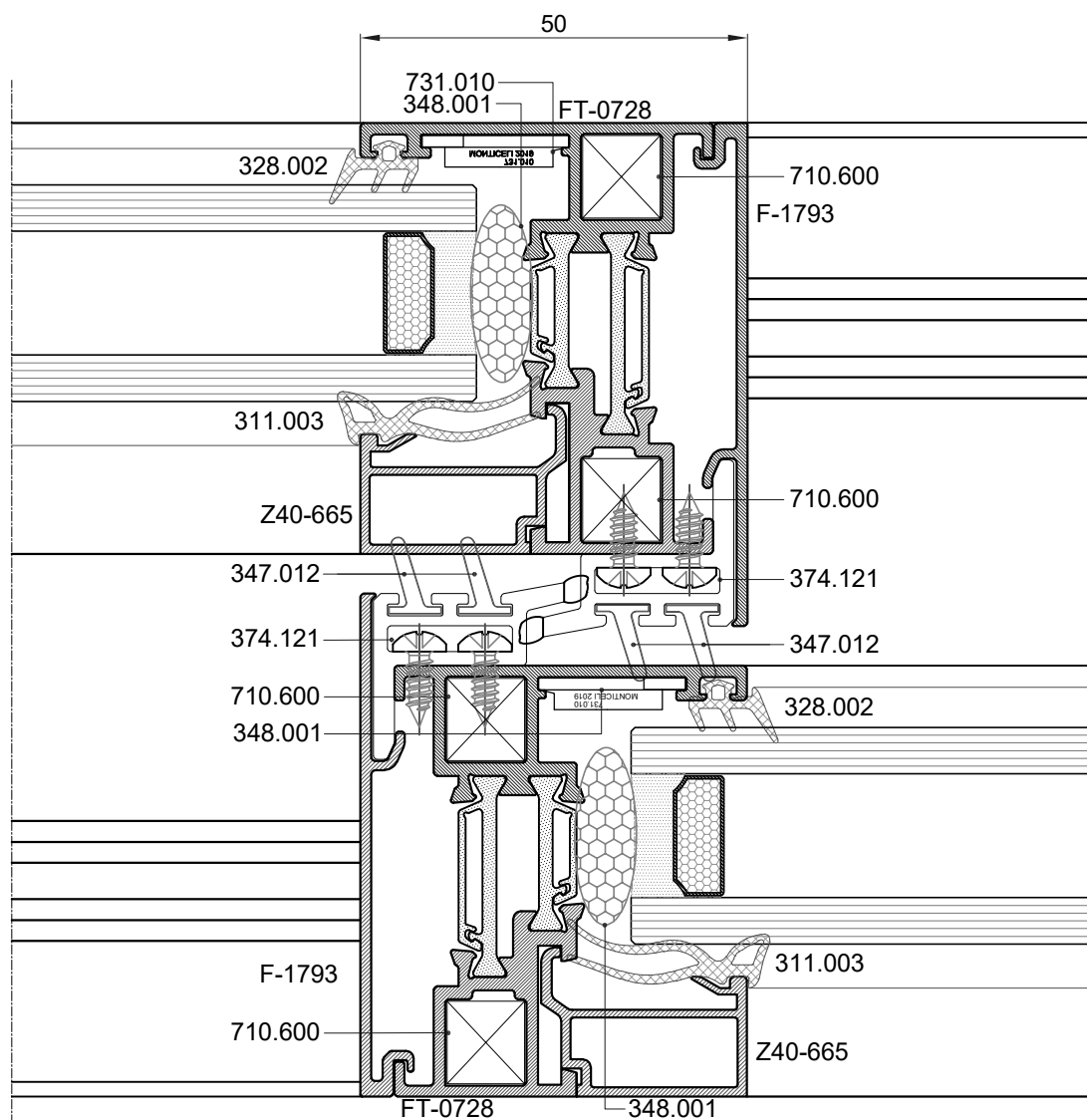
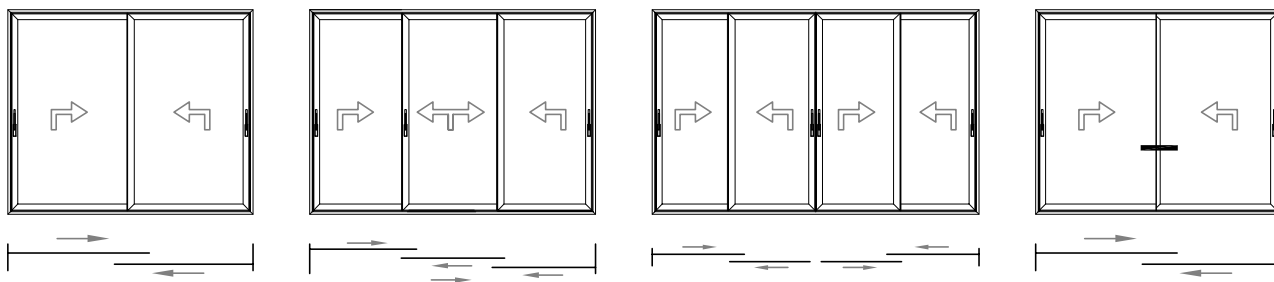

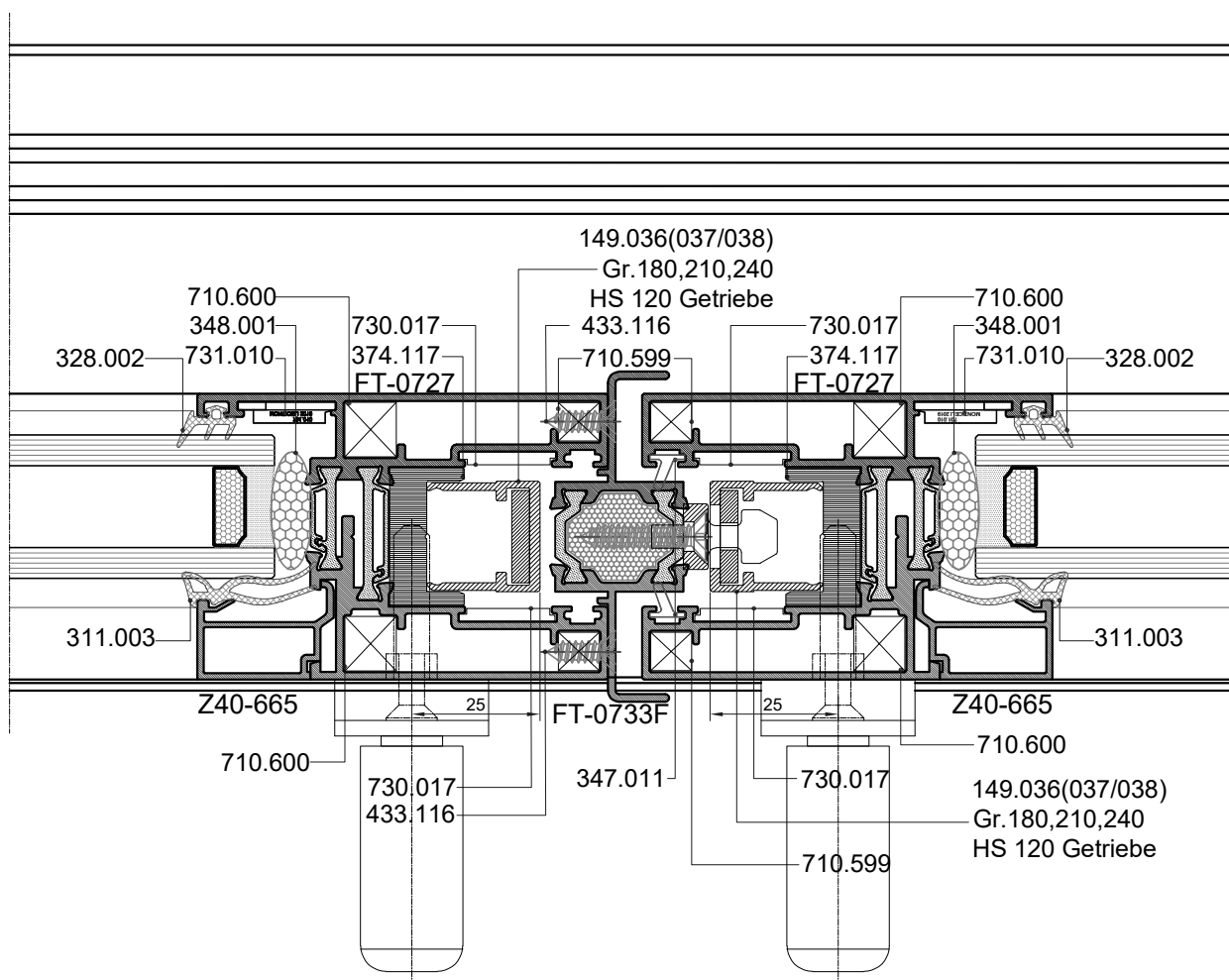
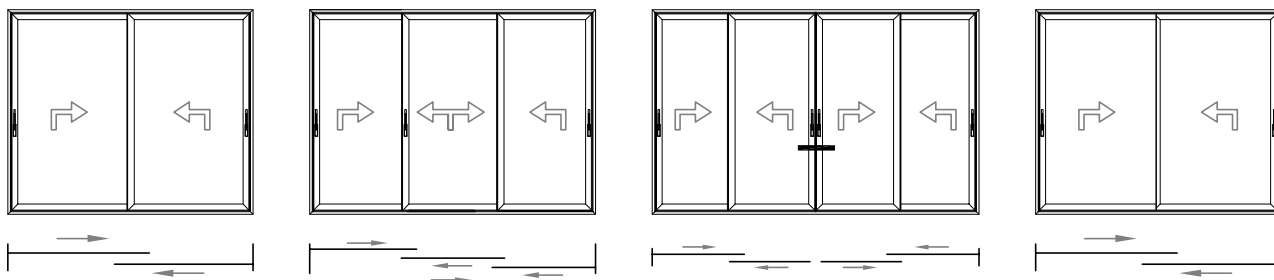

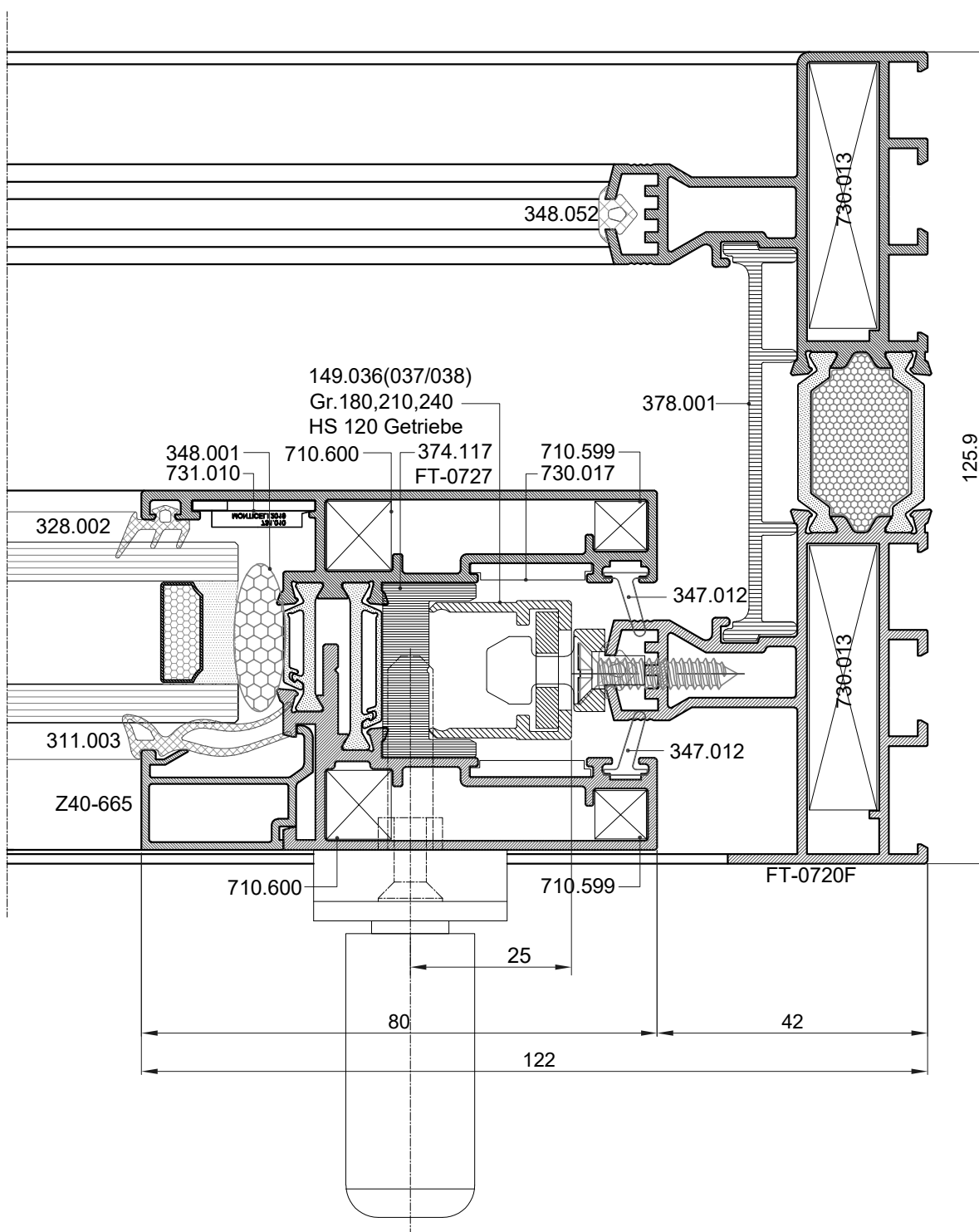
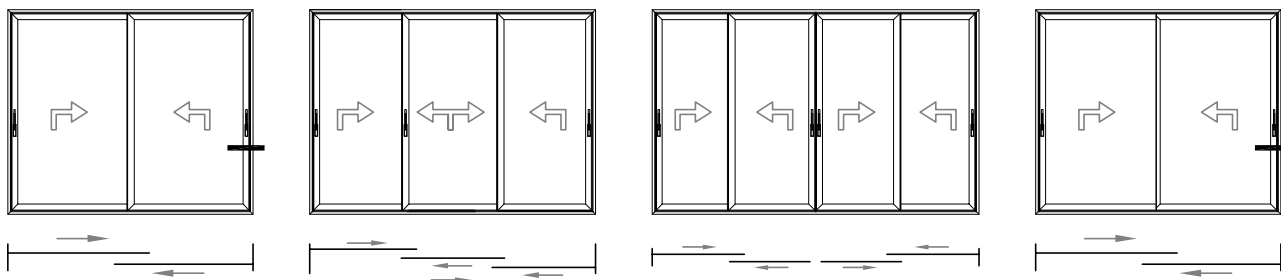

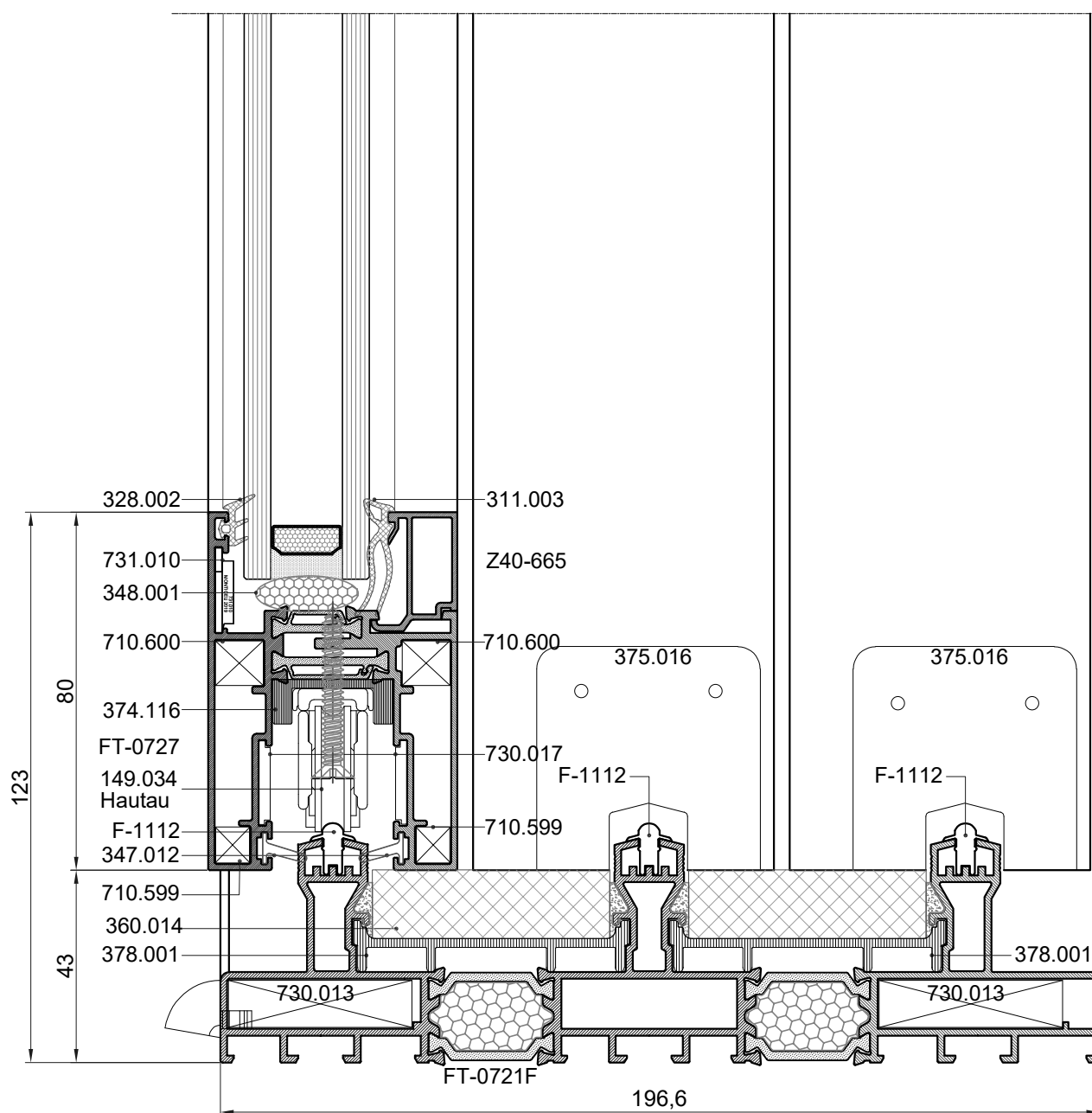
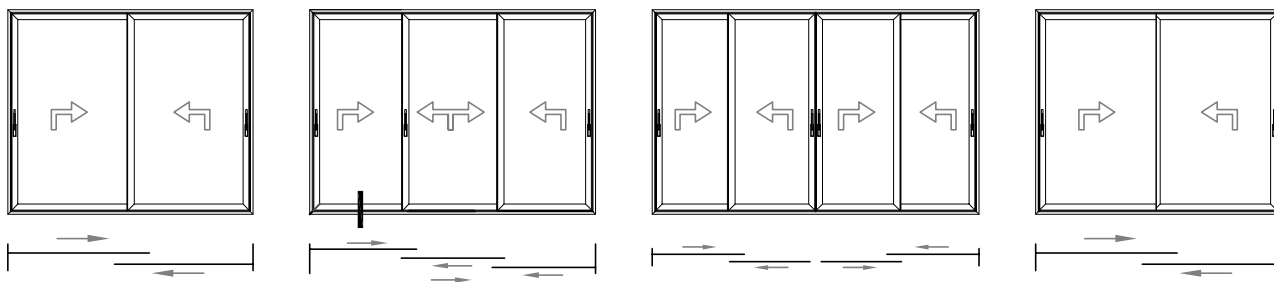

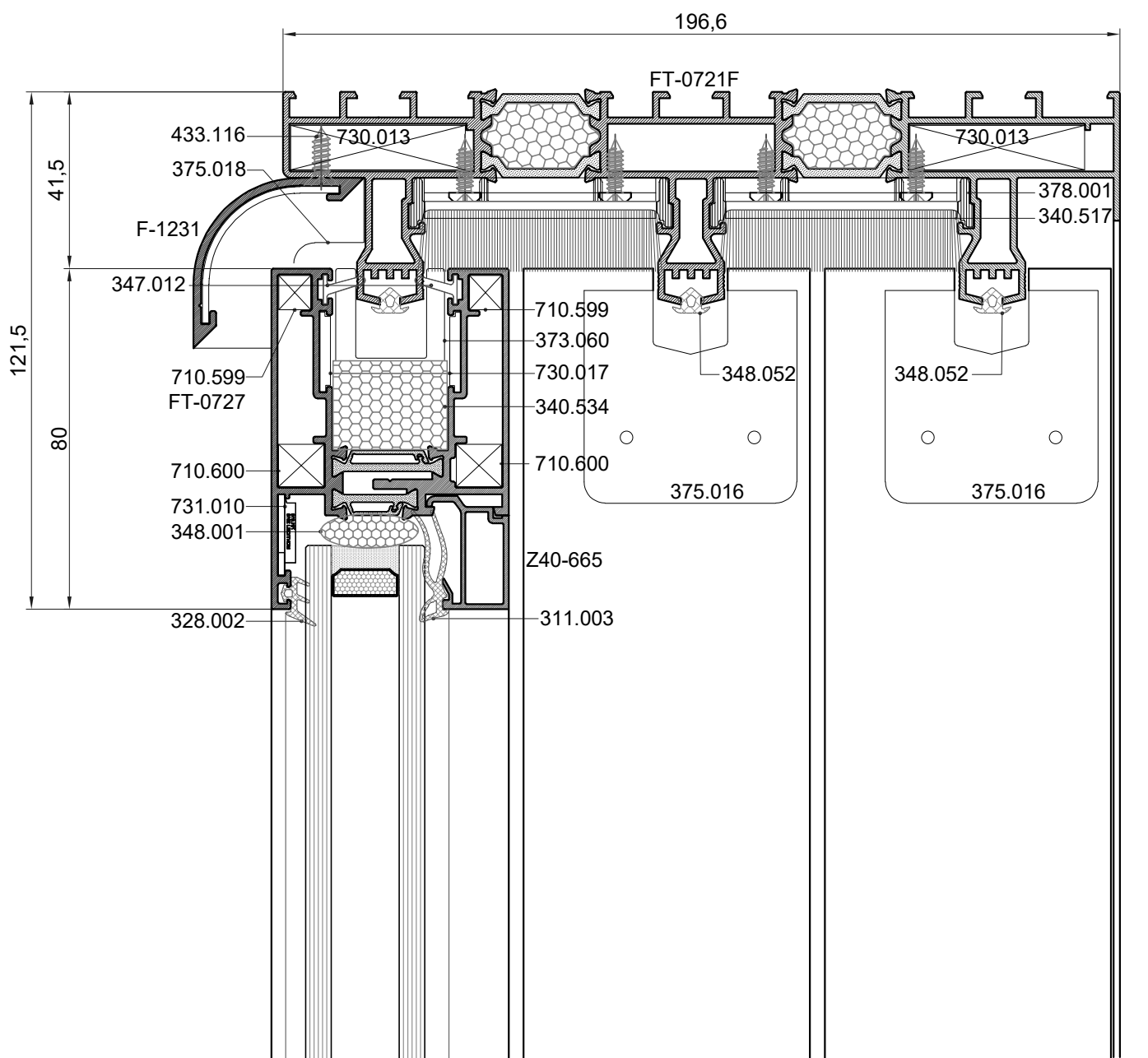
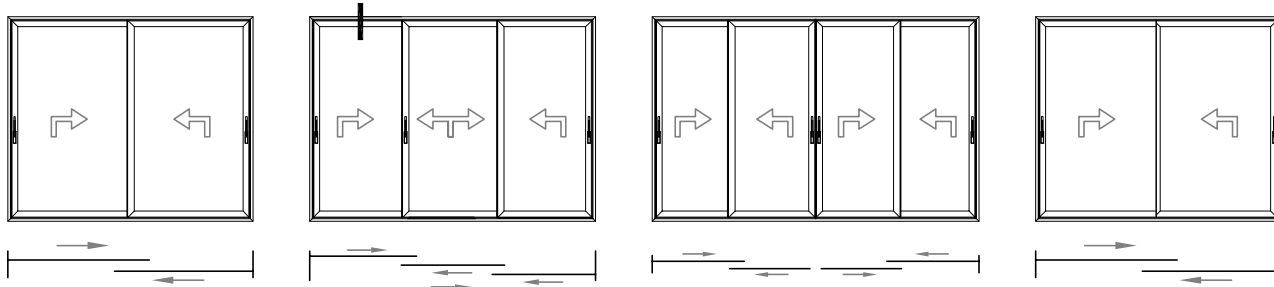

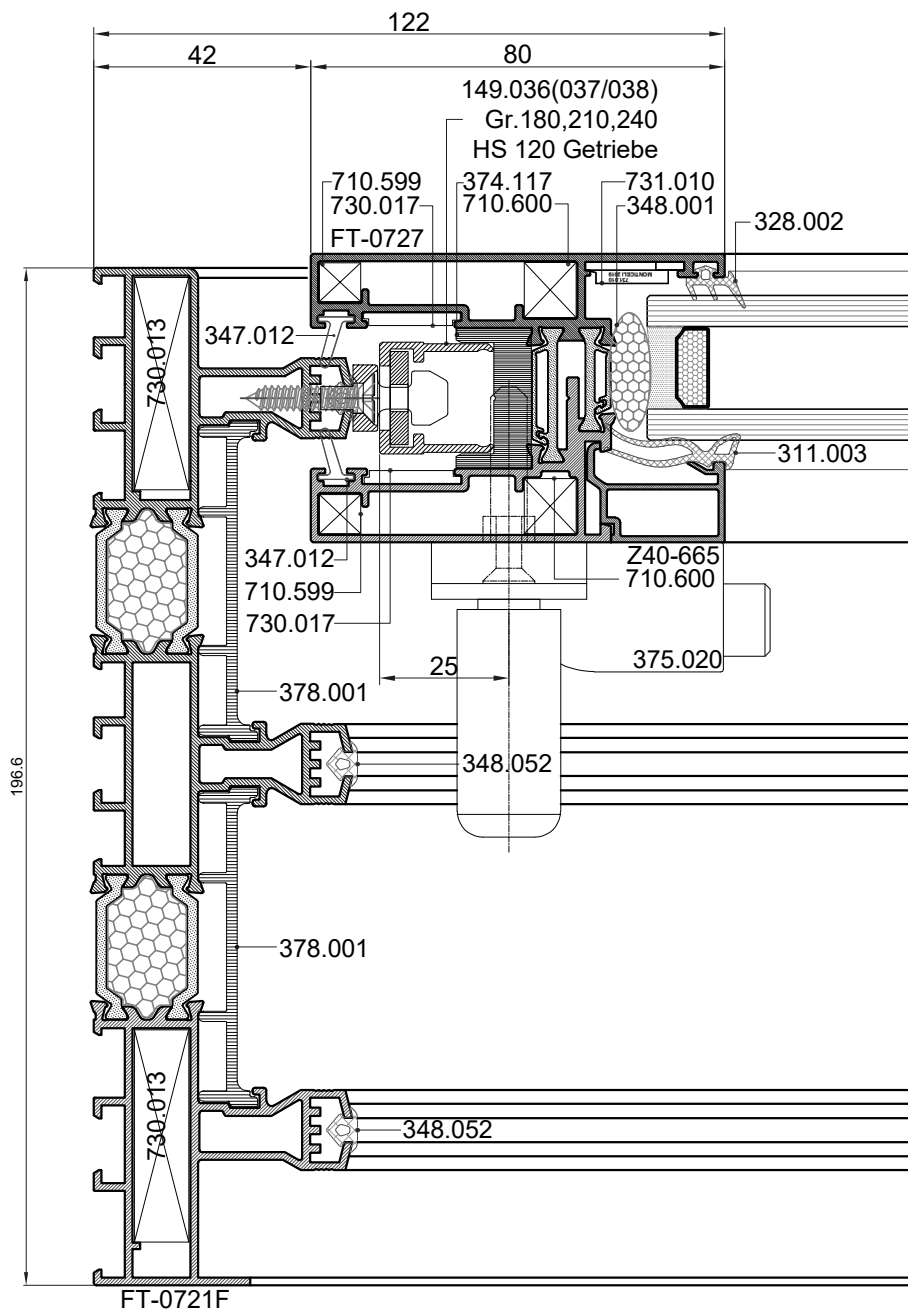
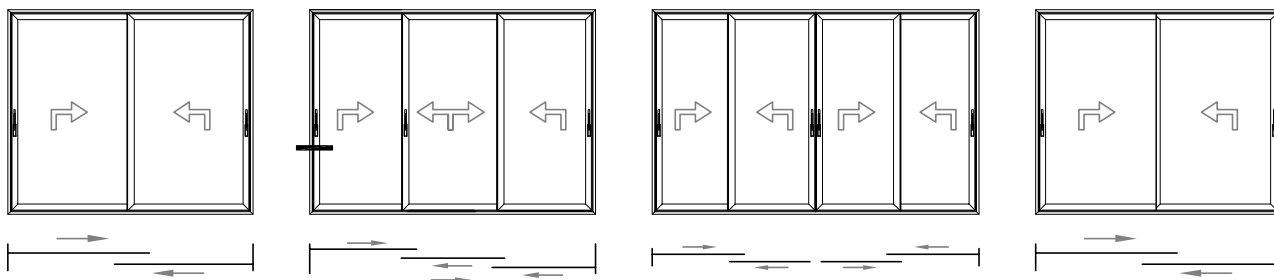

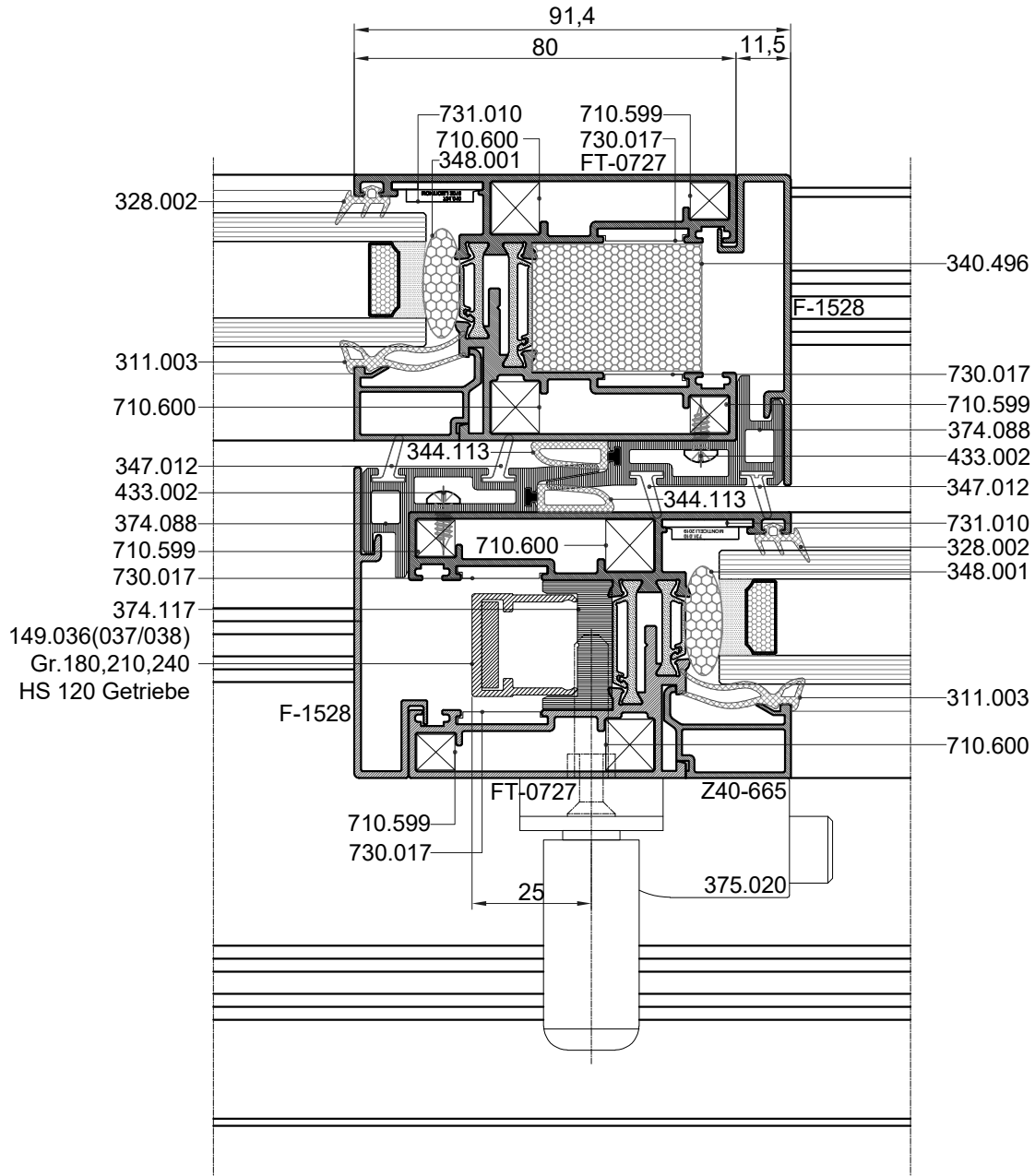
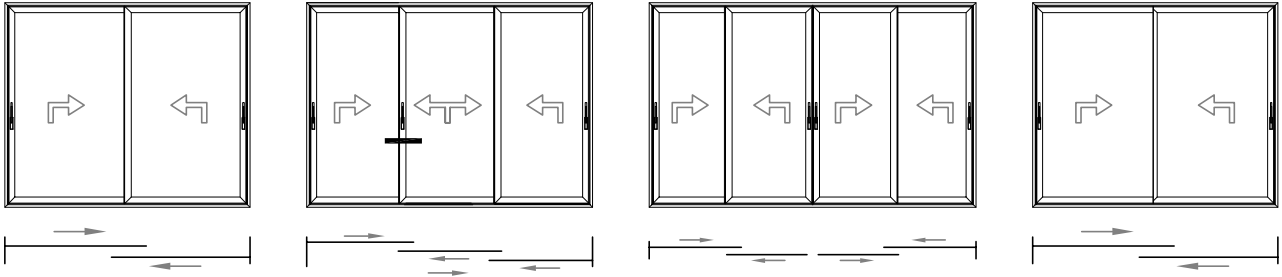

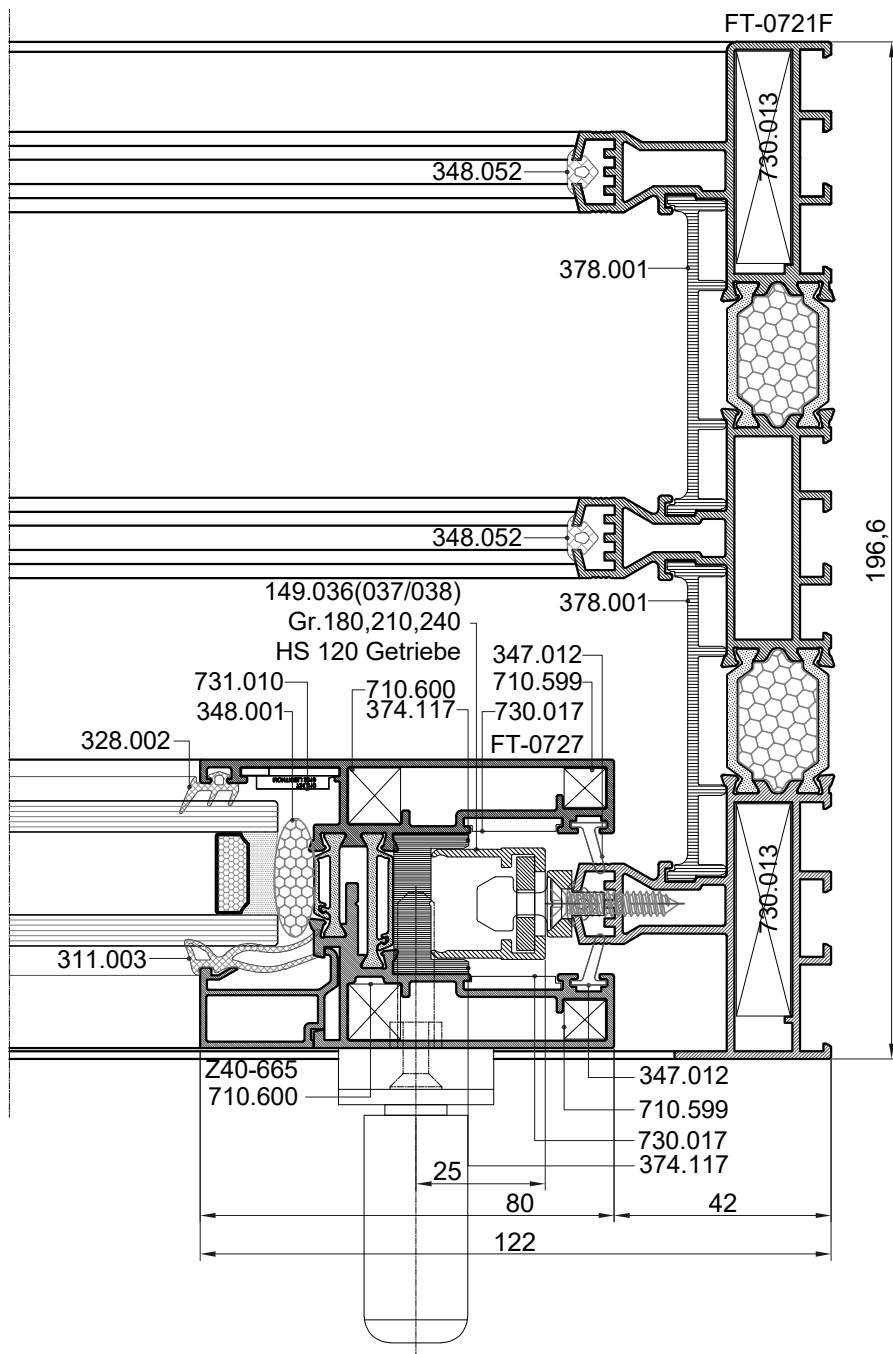
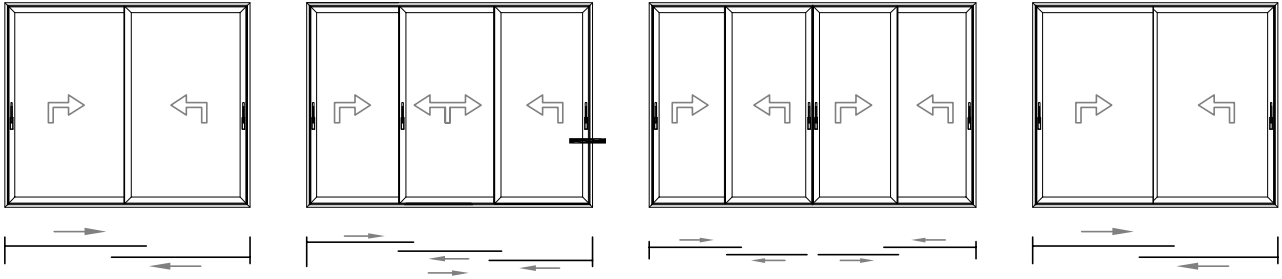

TERMO 120 plus

Presjeci s krilom FT-0725 klizno s integriranim fiksnim poljem

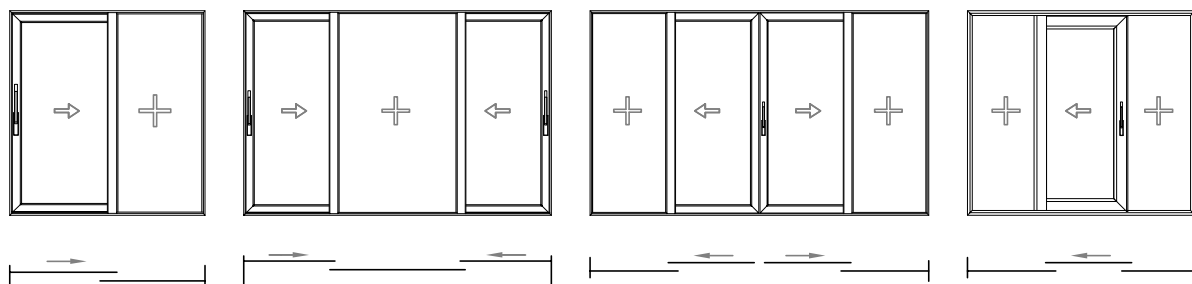

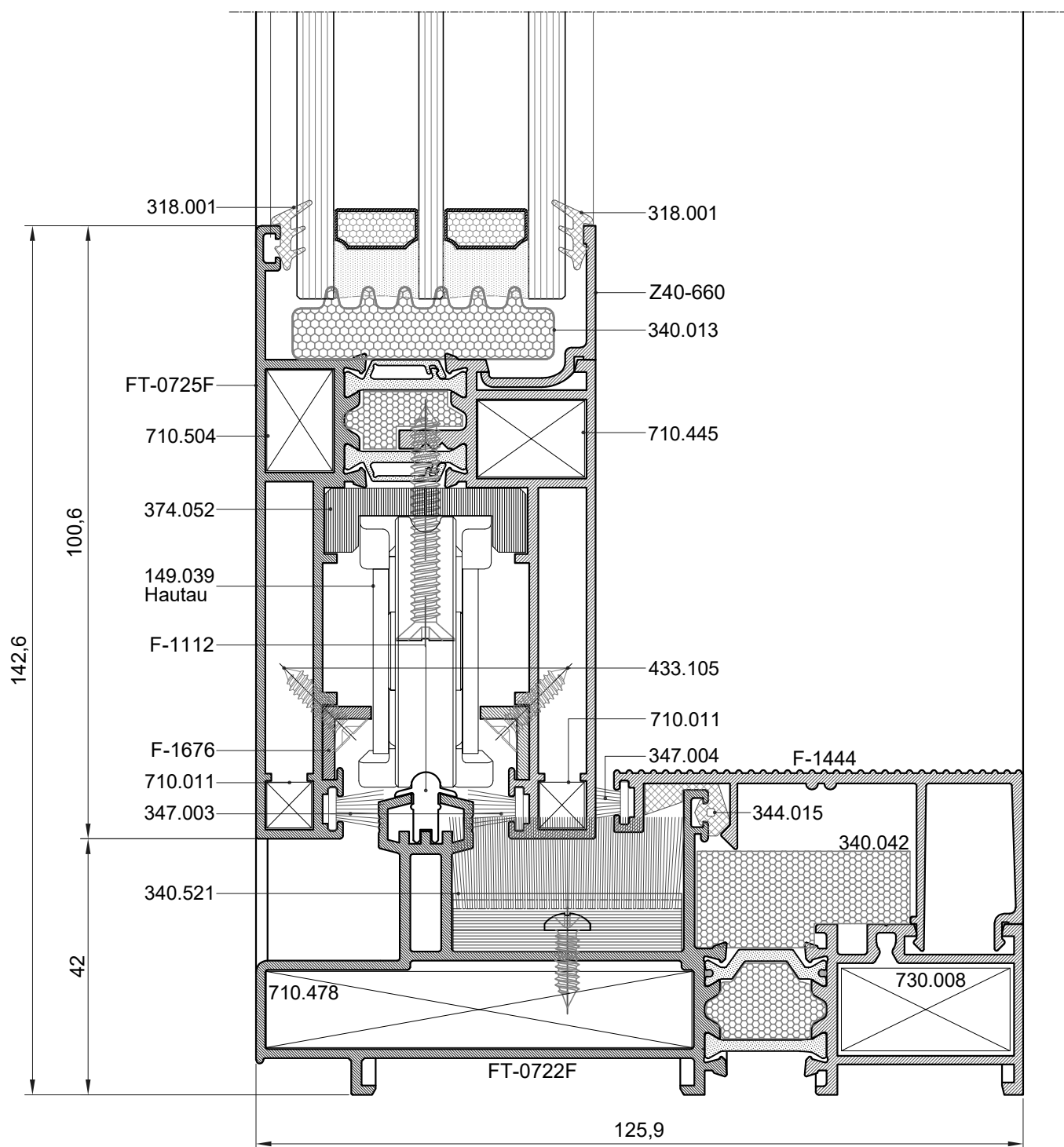
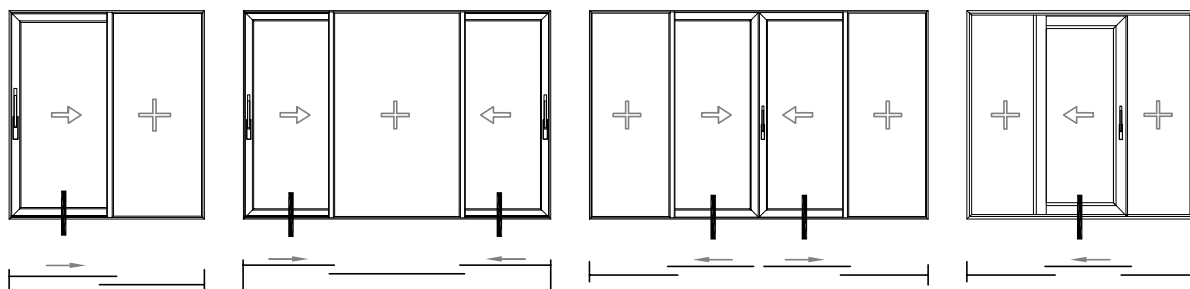

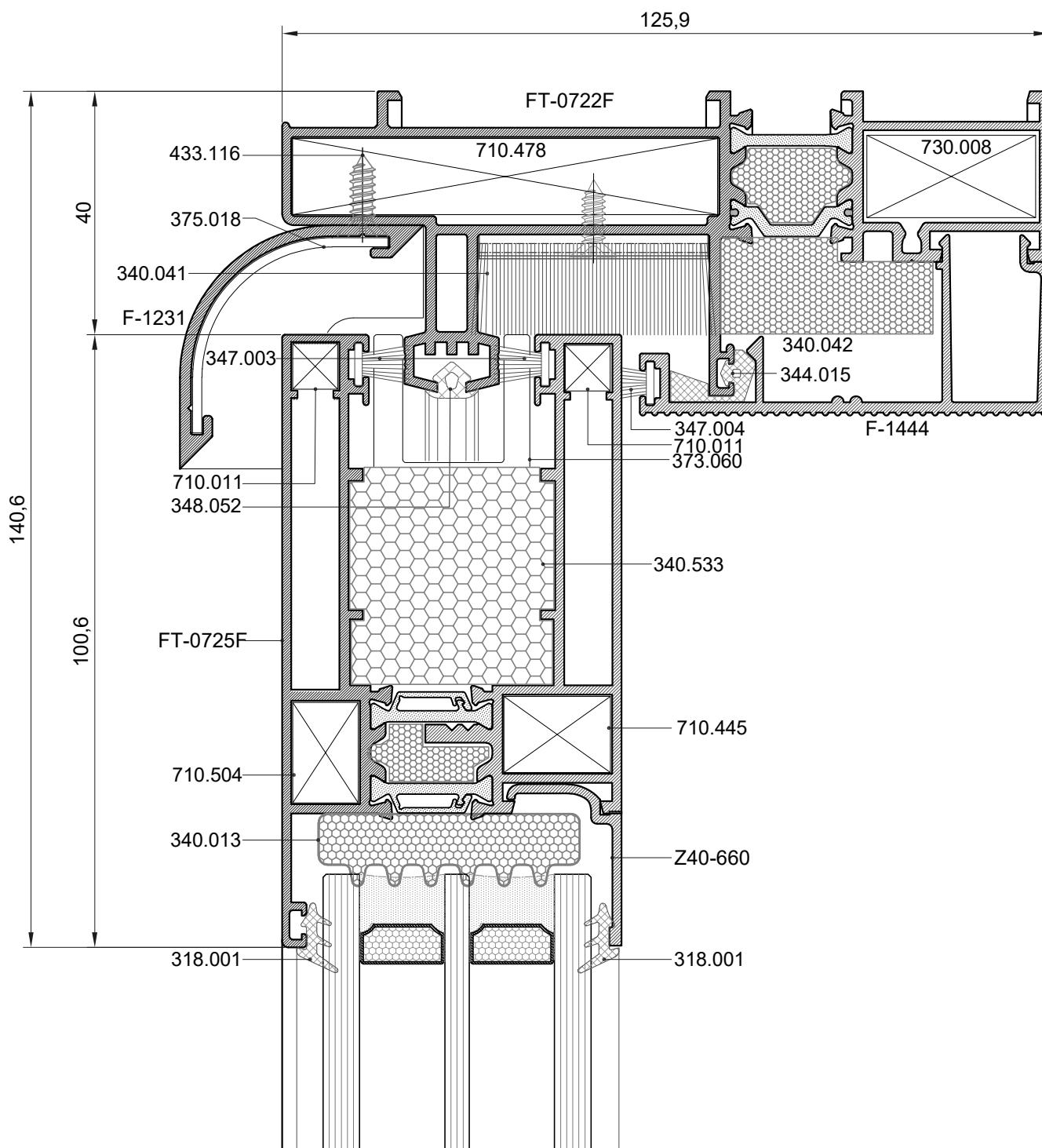
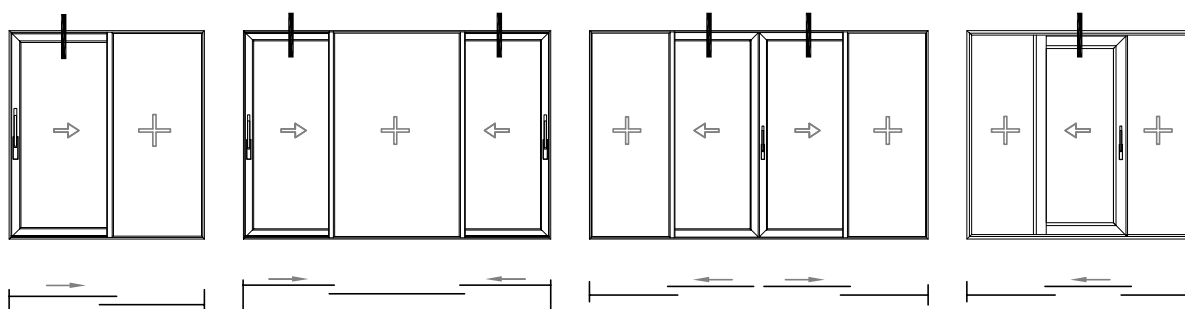

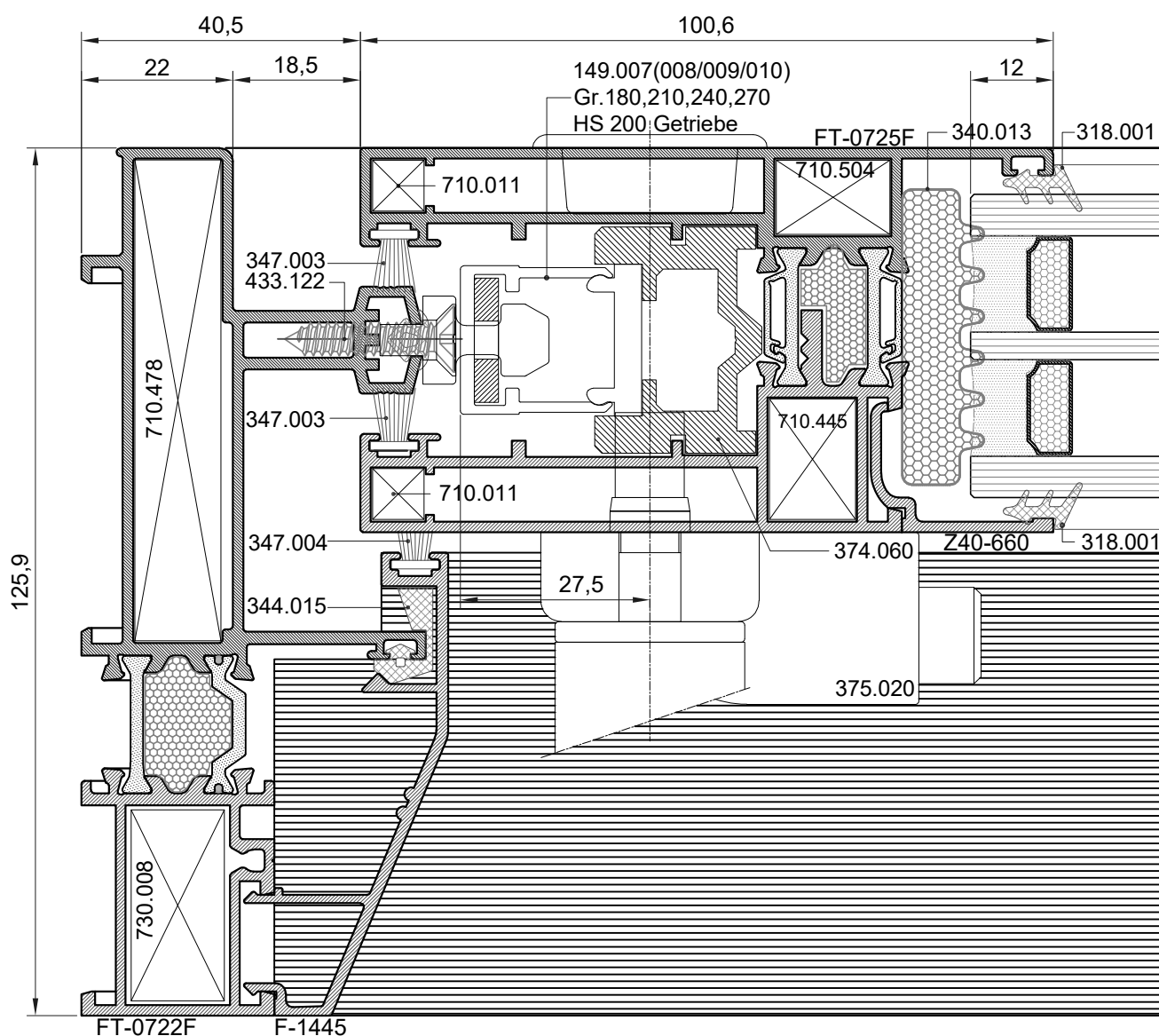
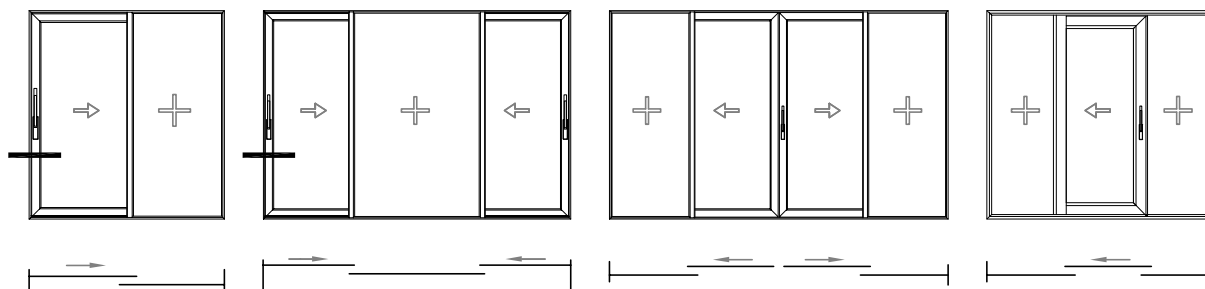

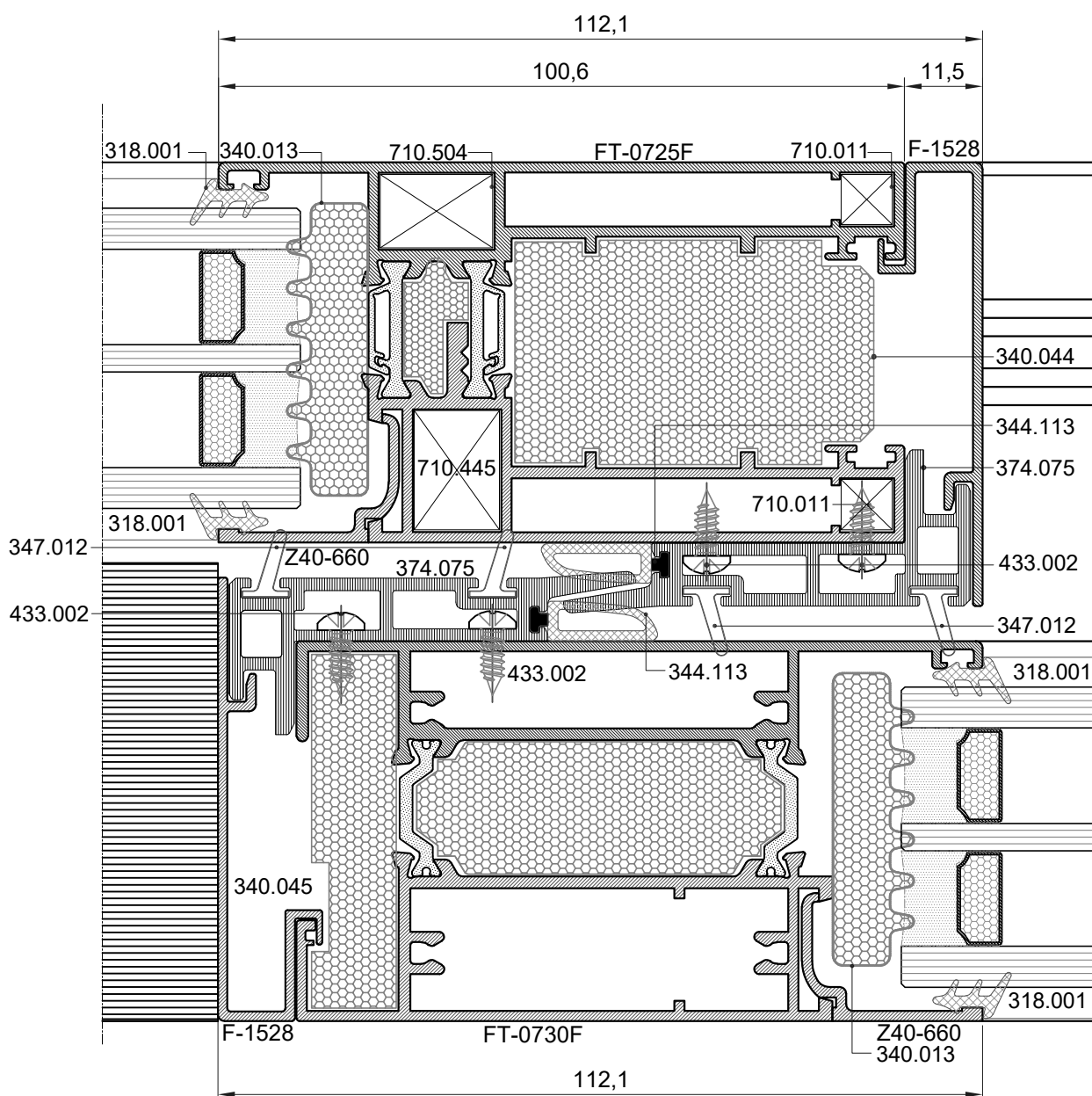
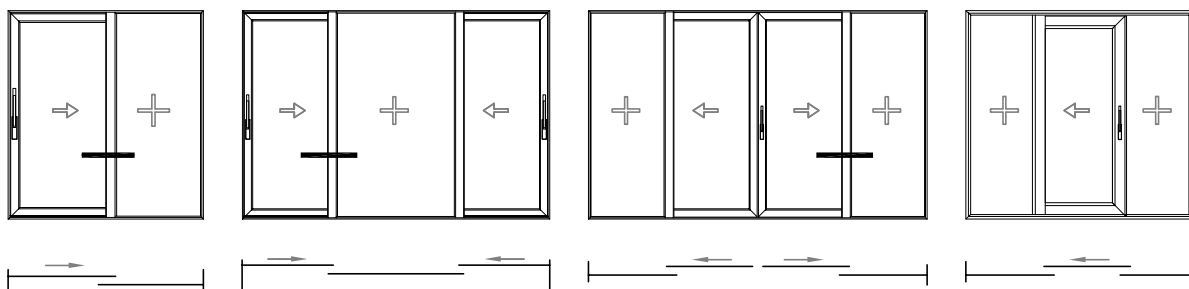

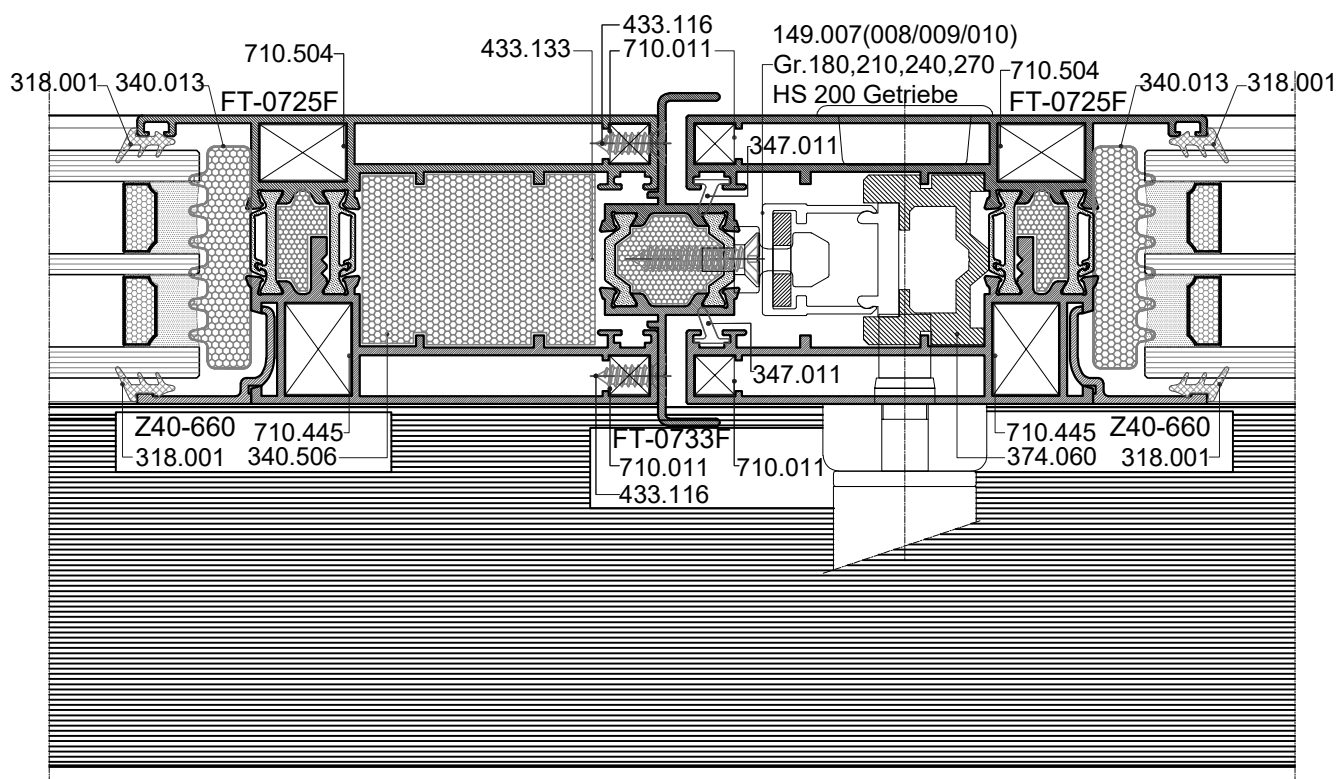
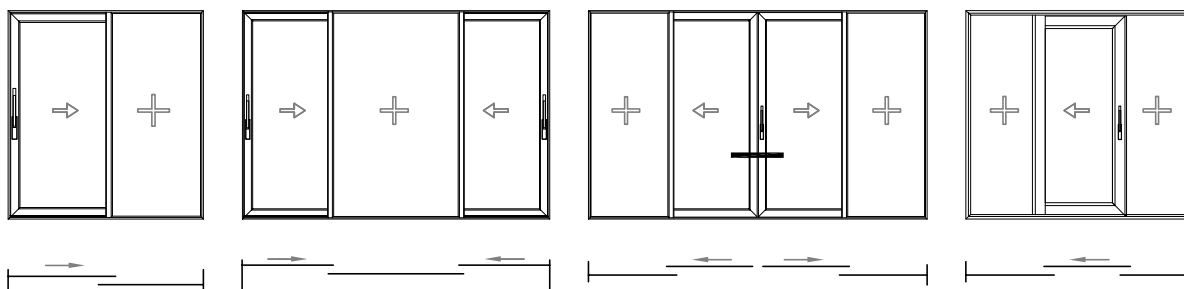

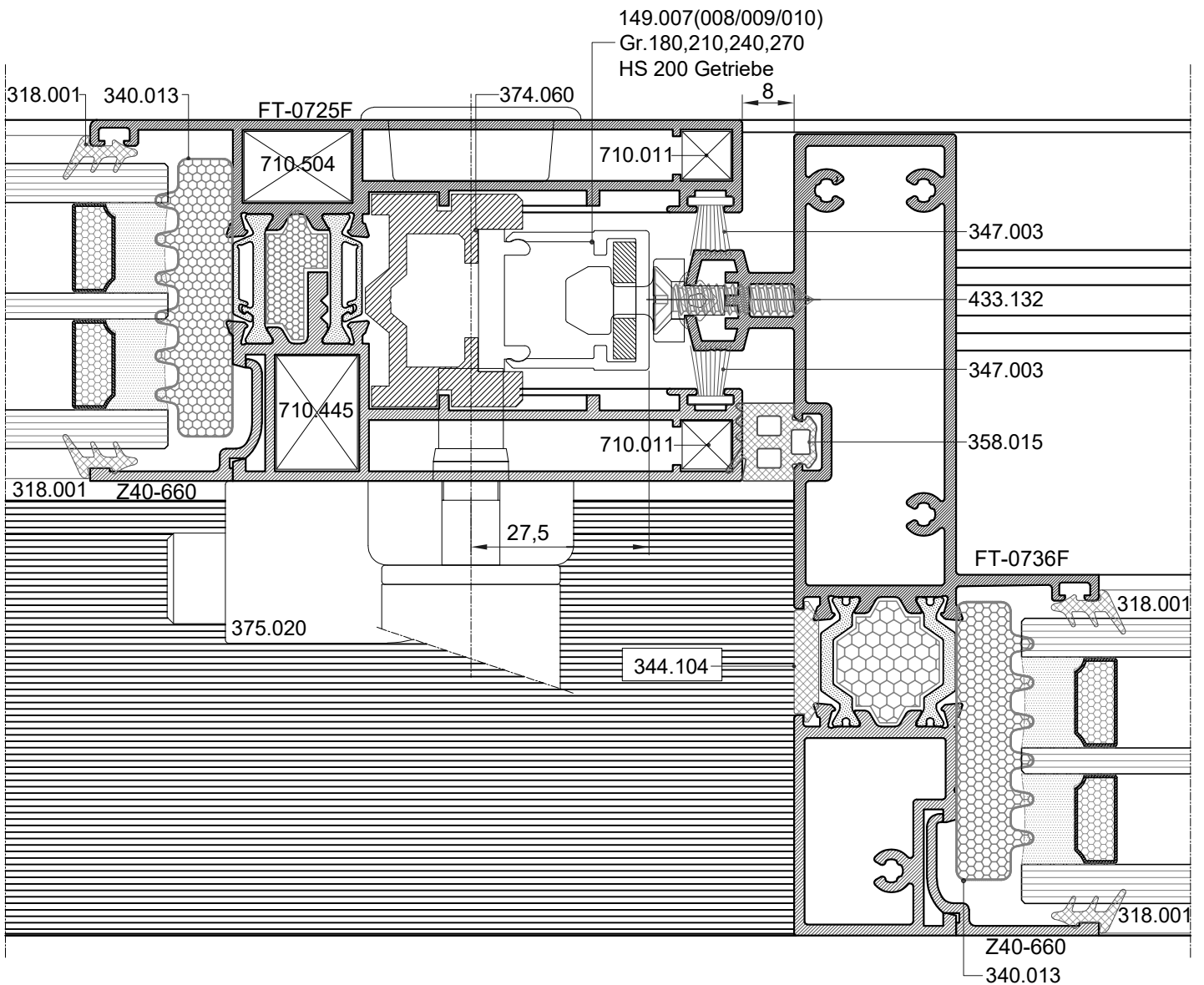
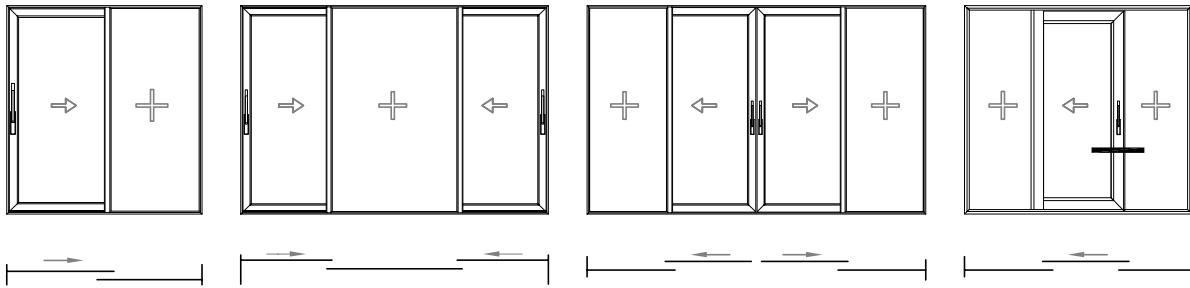

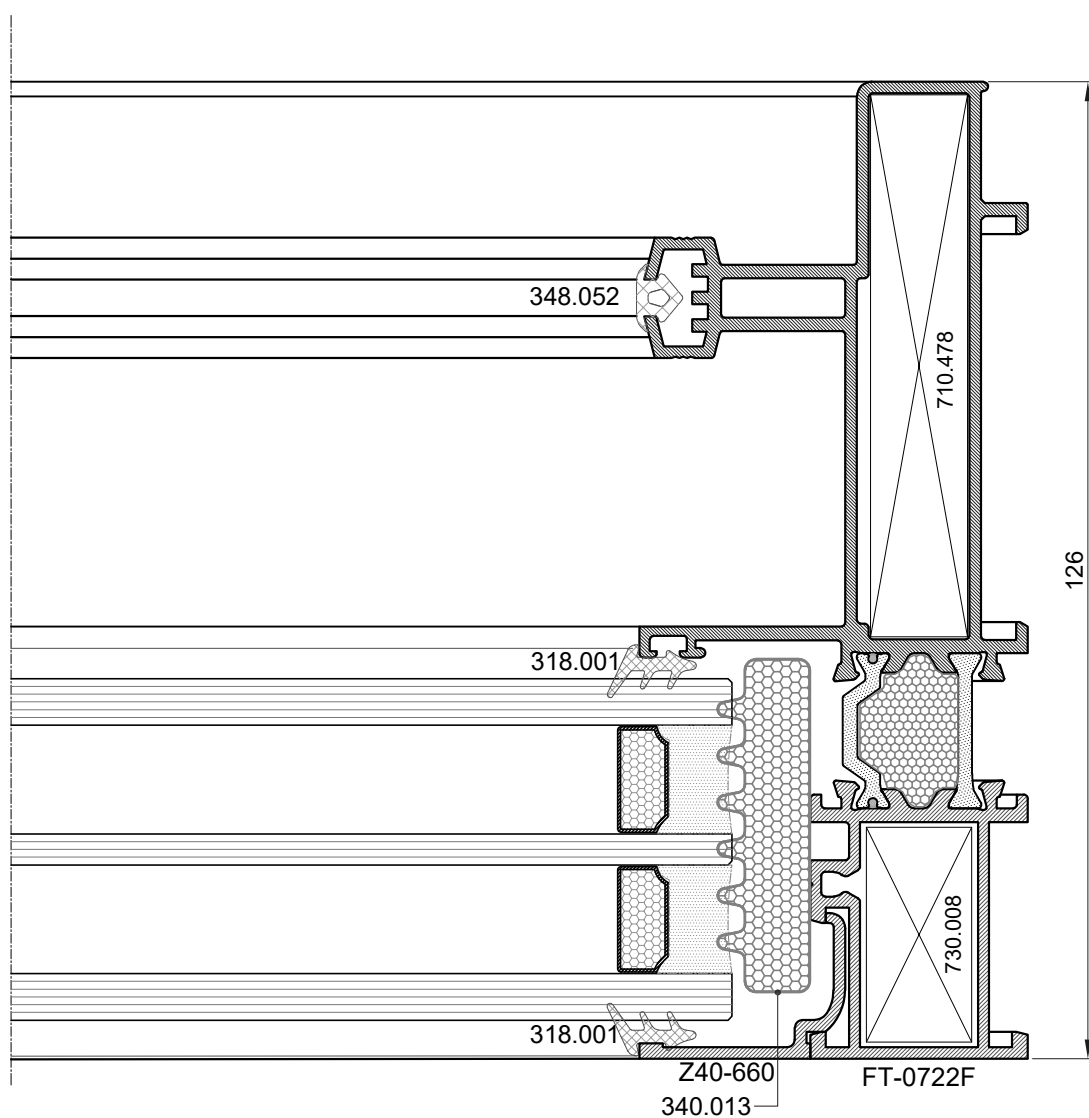
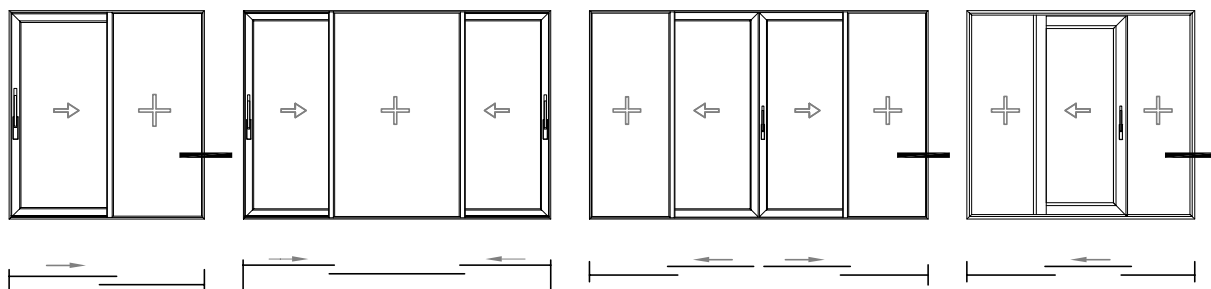

Presjeci s krilom FT-0727 klizno s integriranim fiksnim poljem

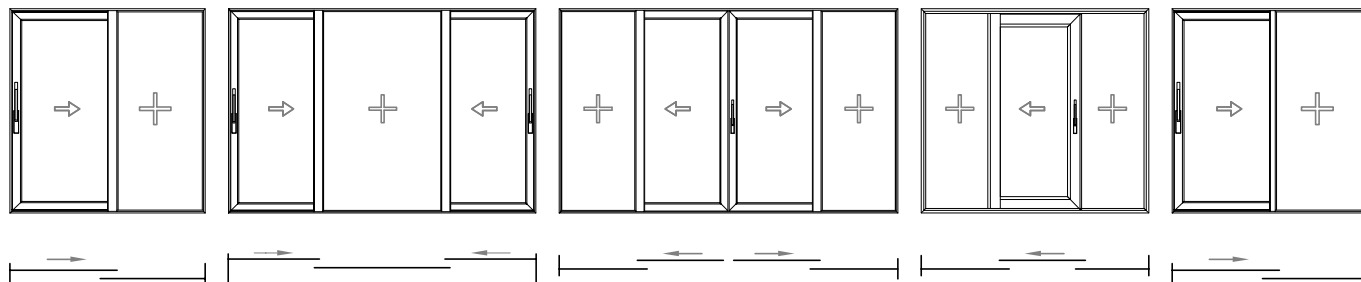

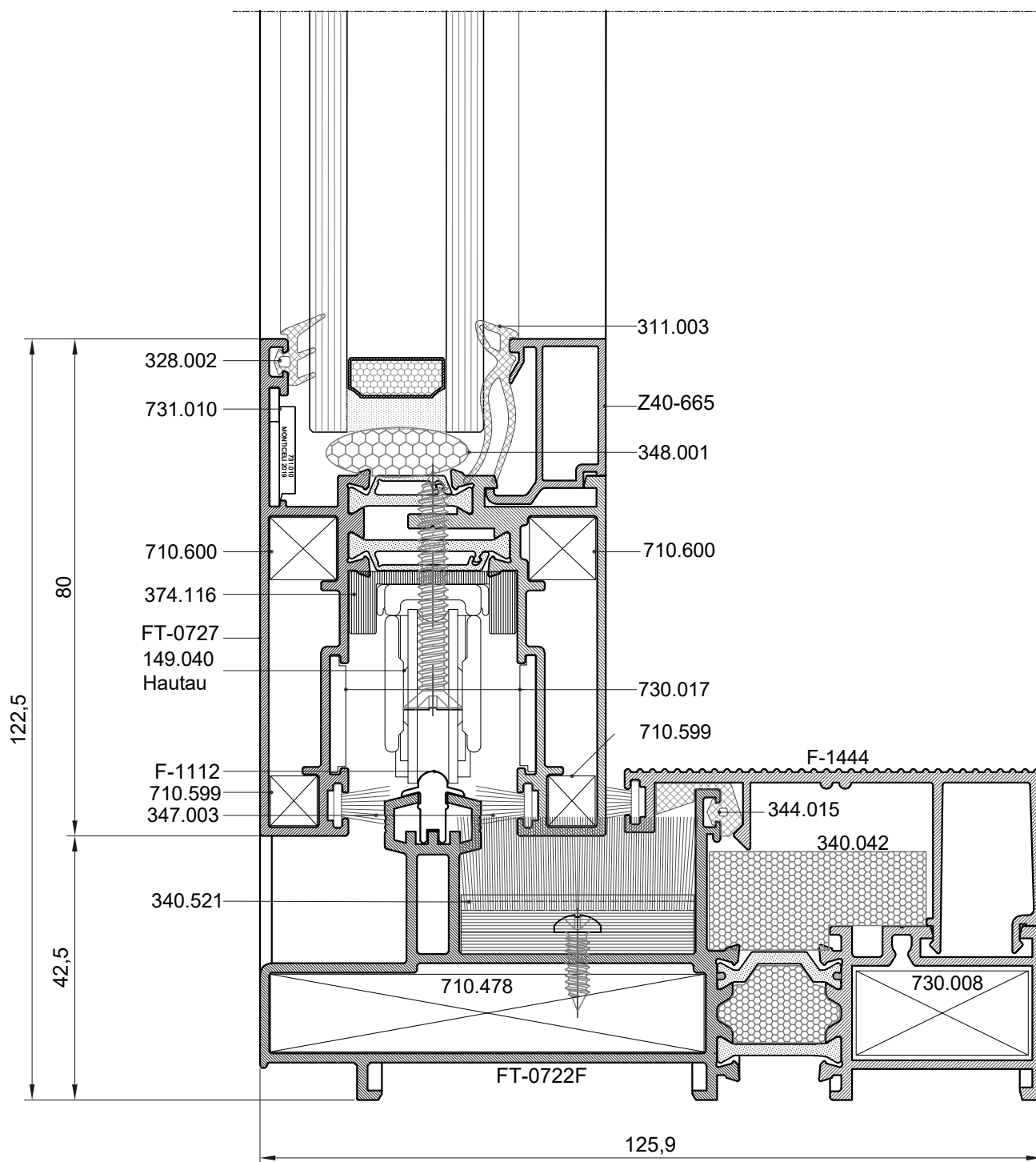
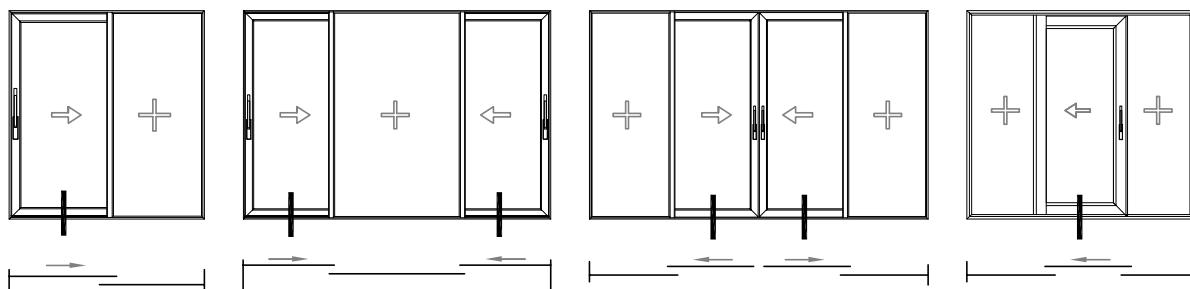

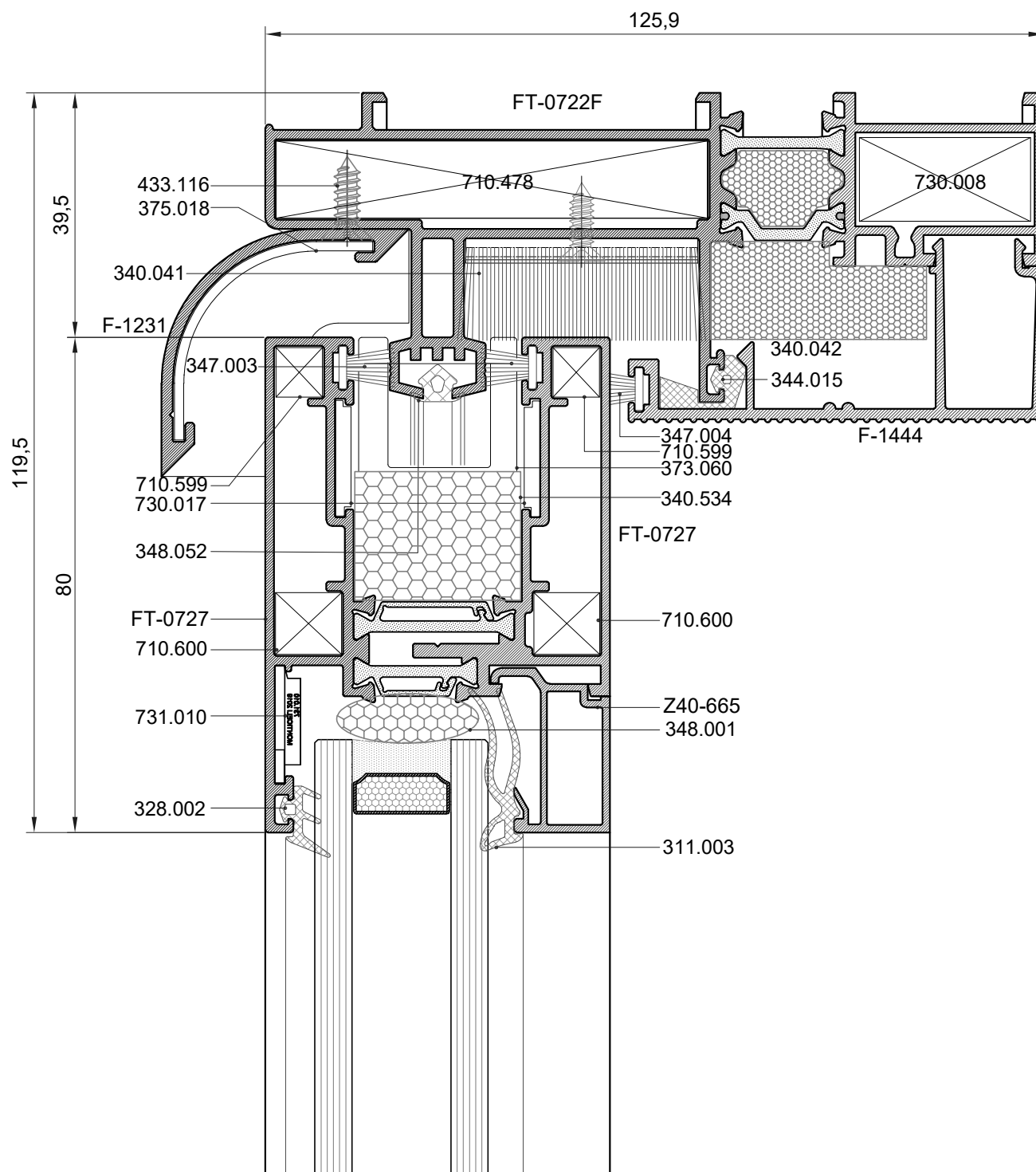
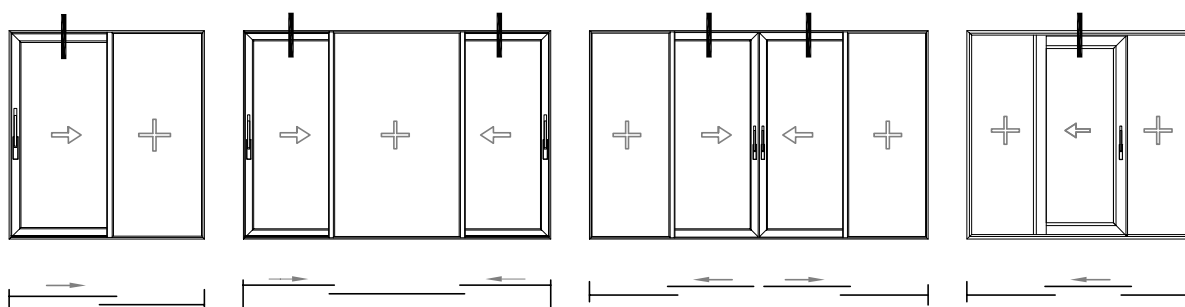

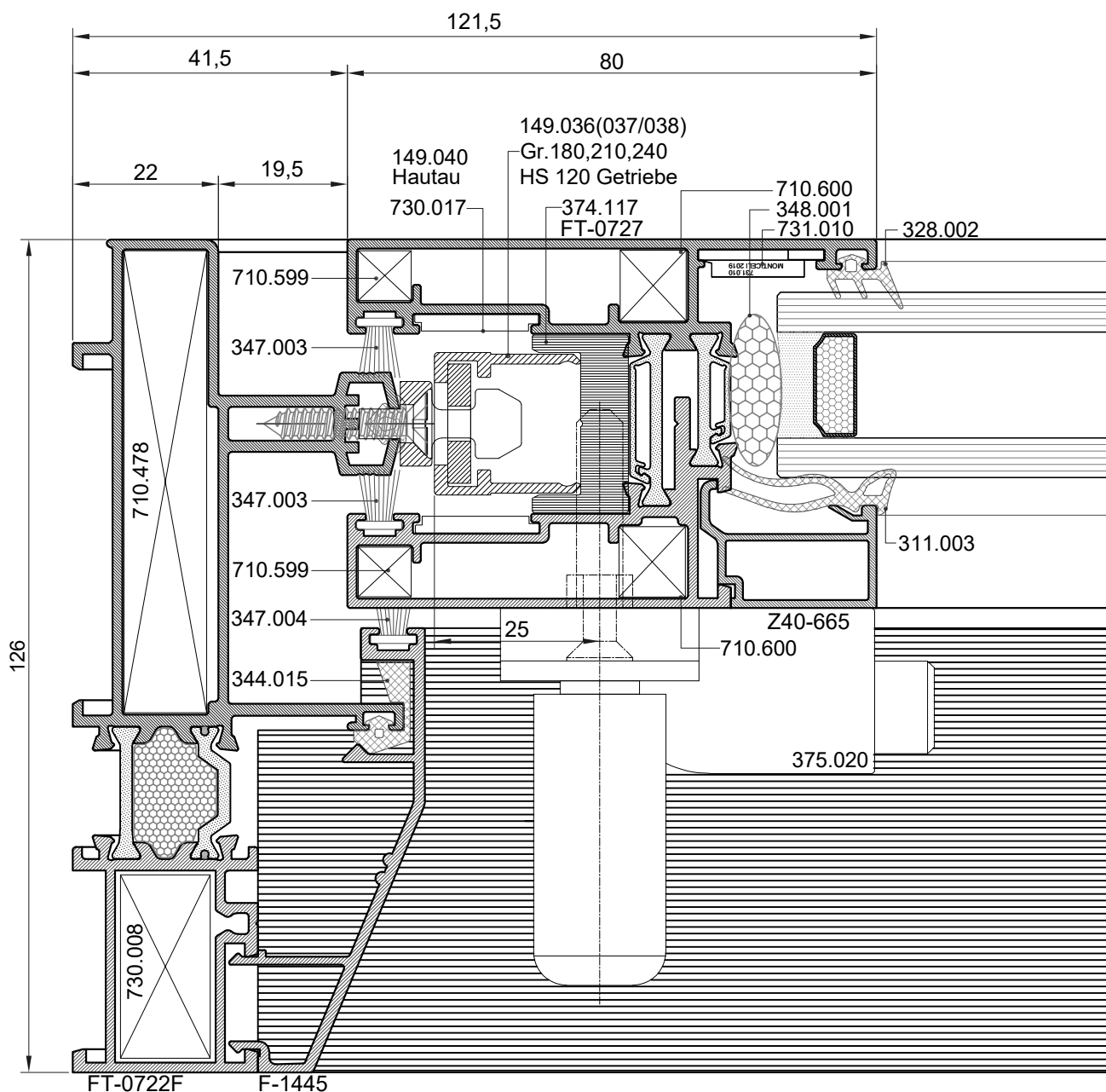
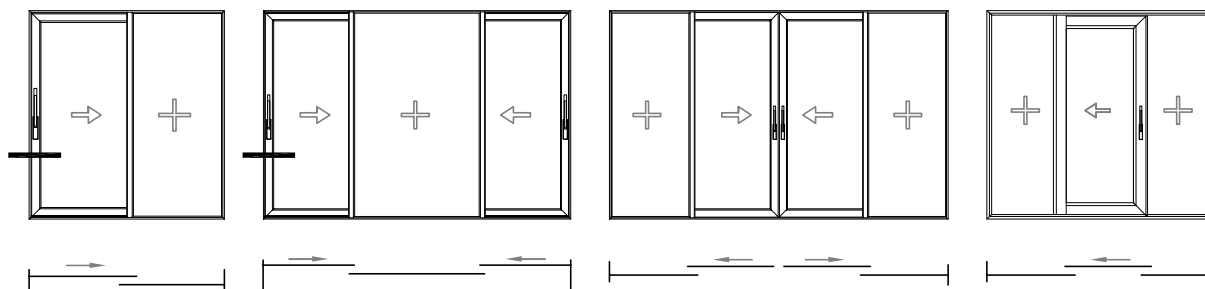

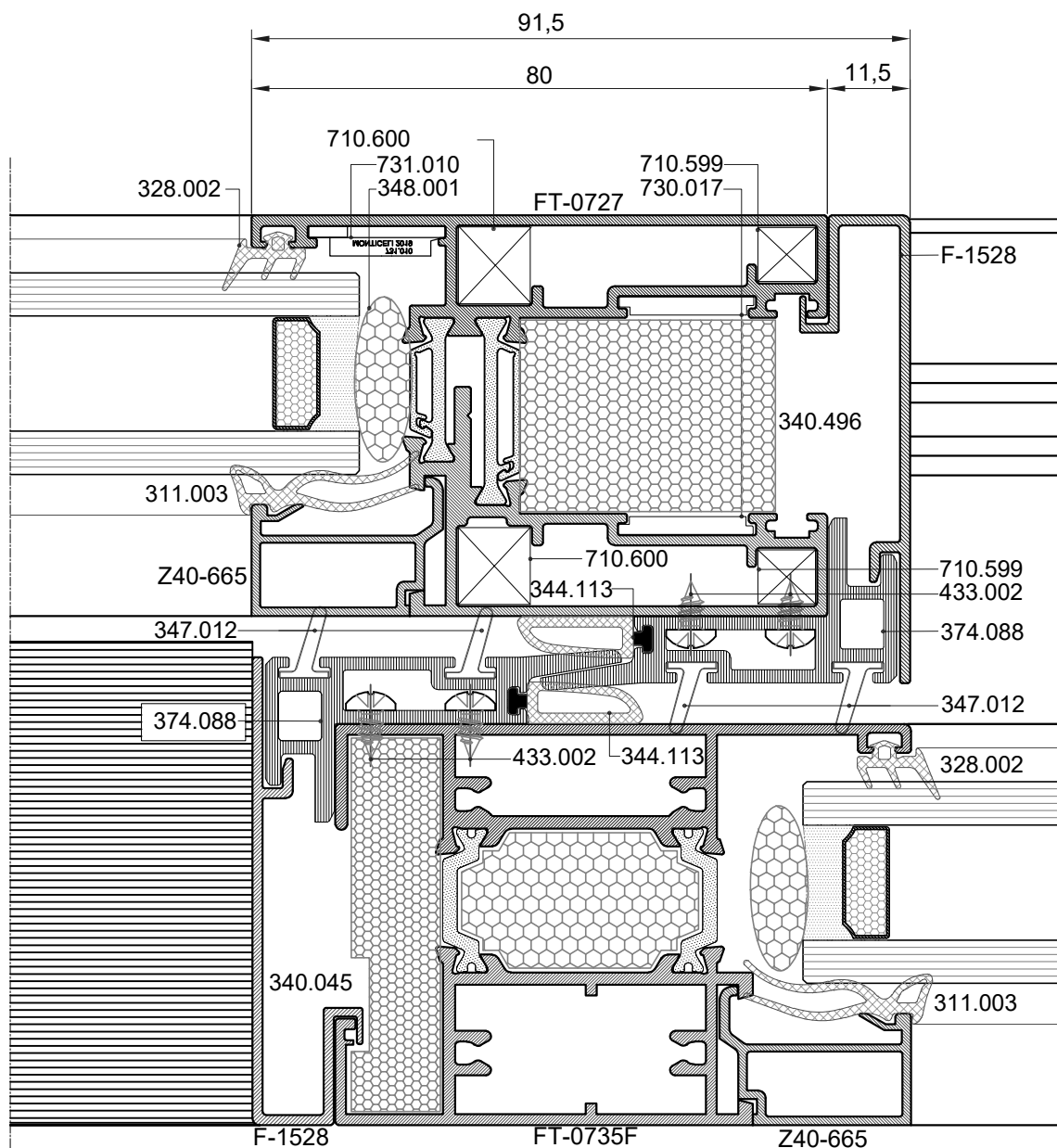
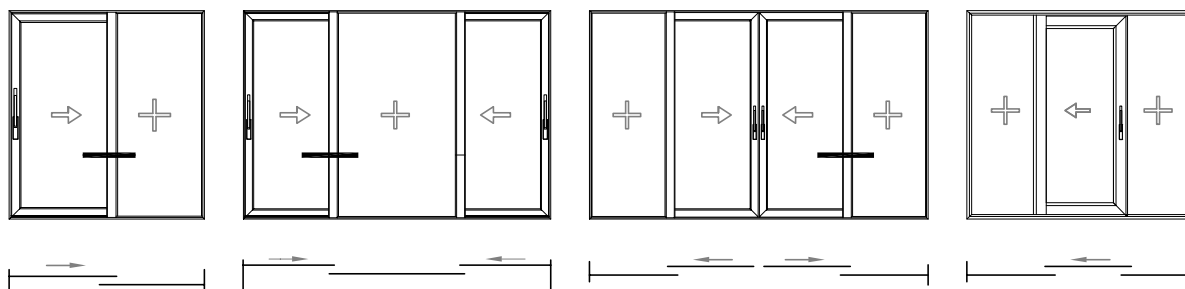

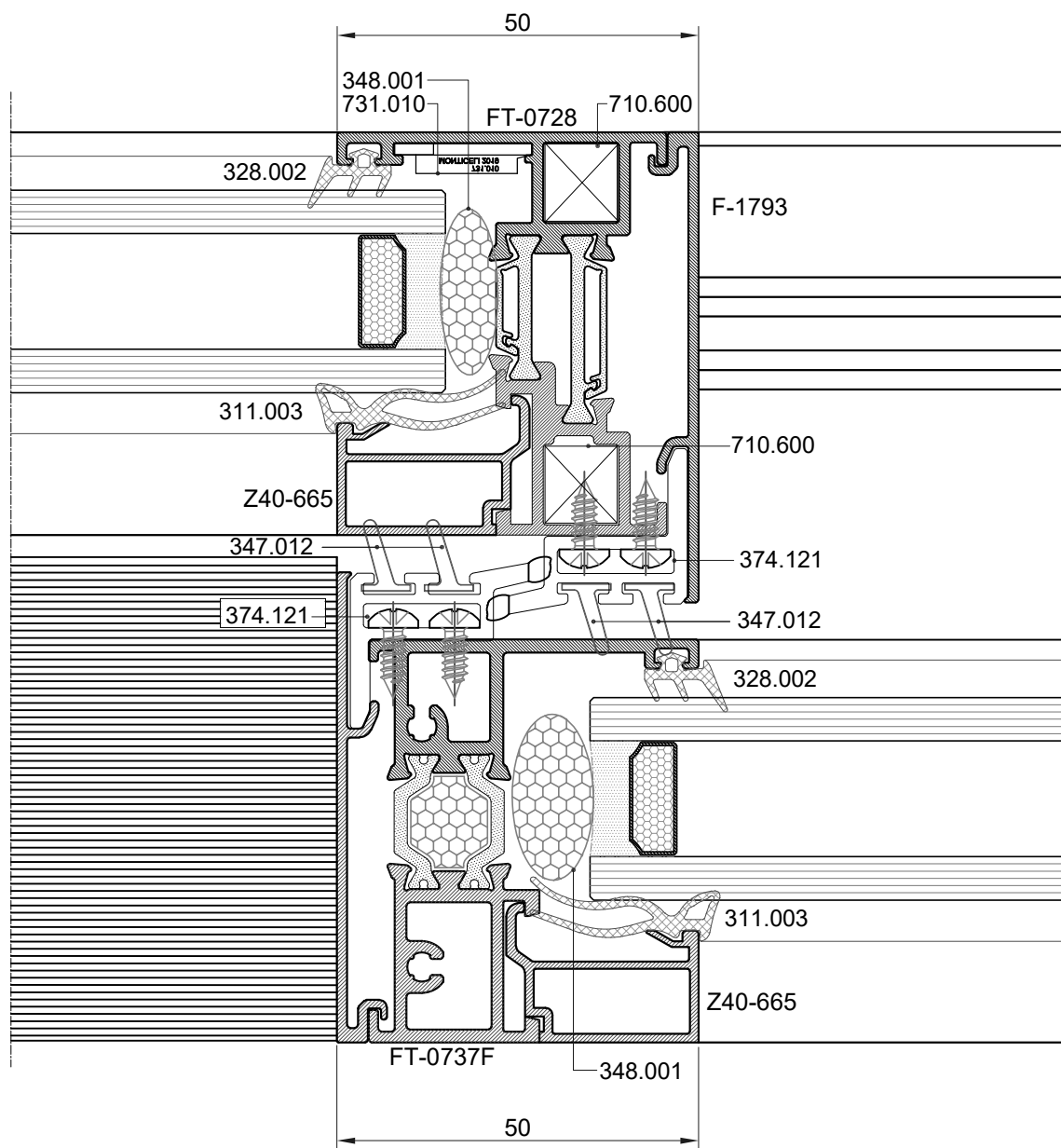
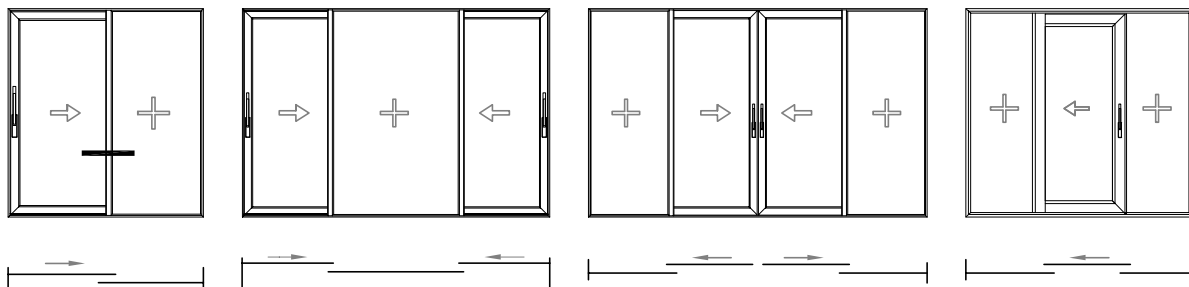

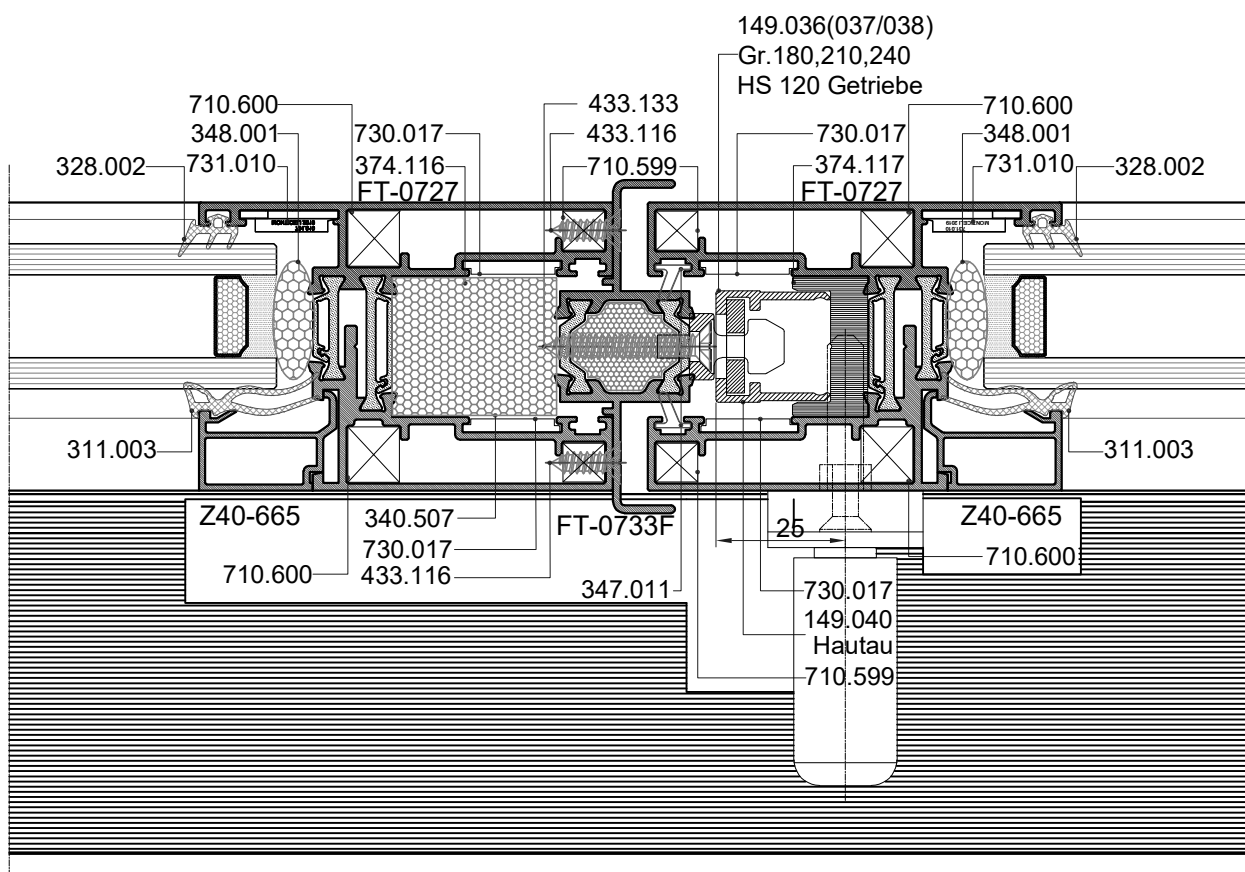
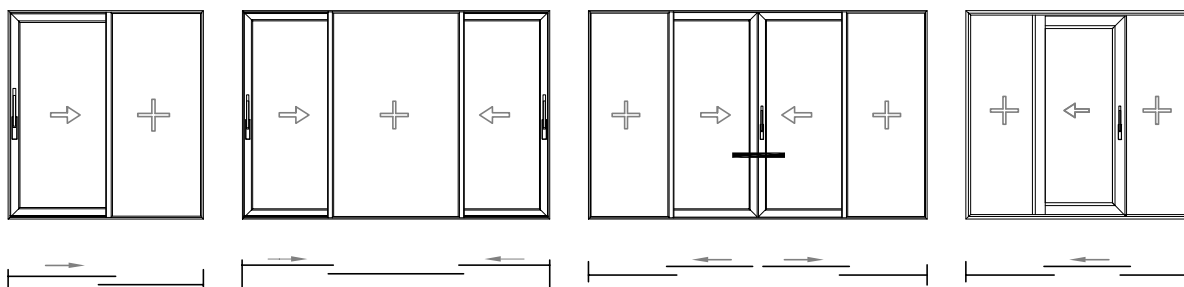

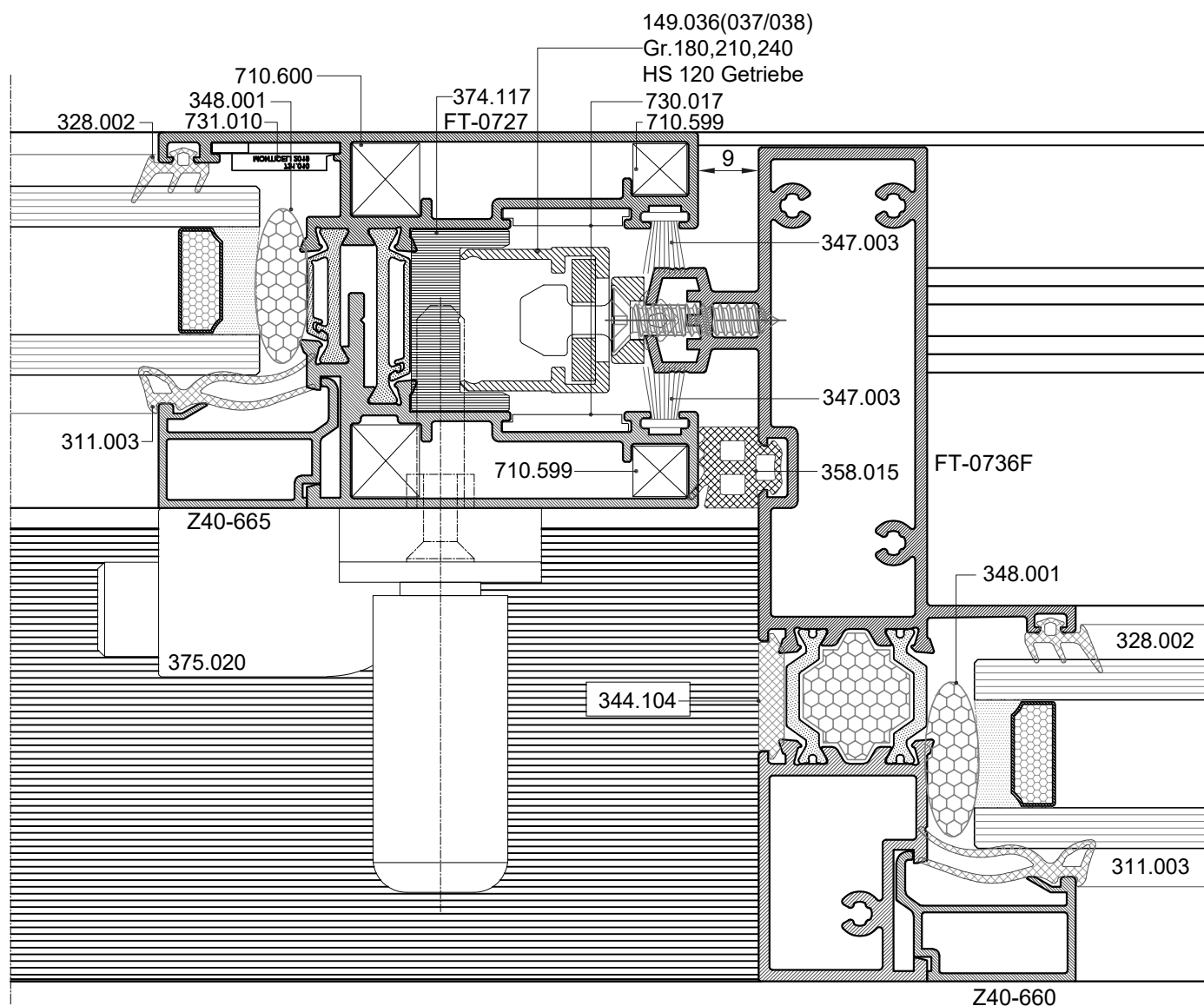
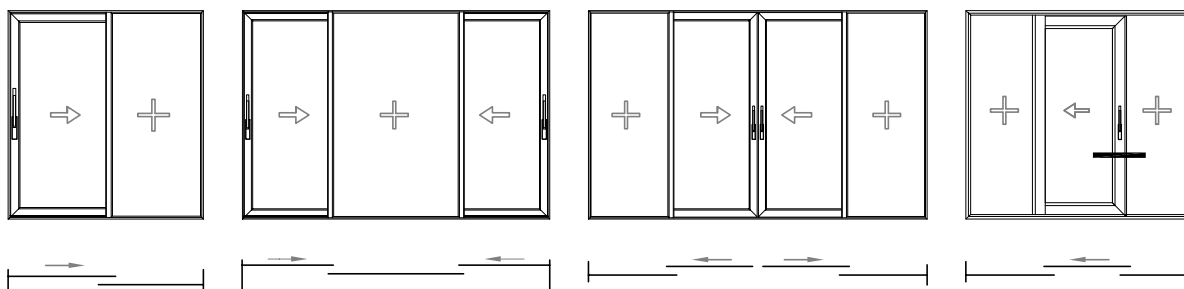

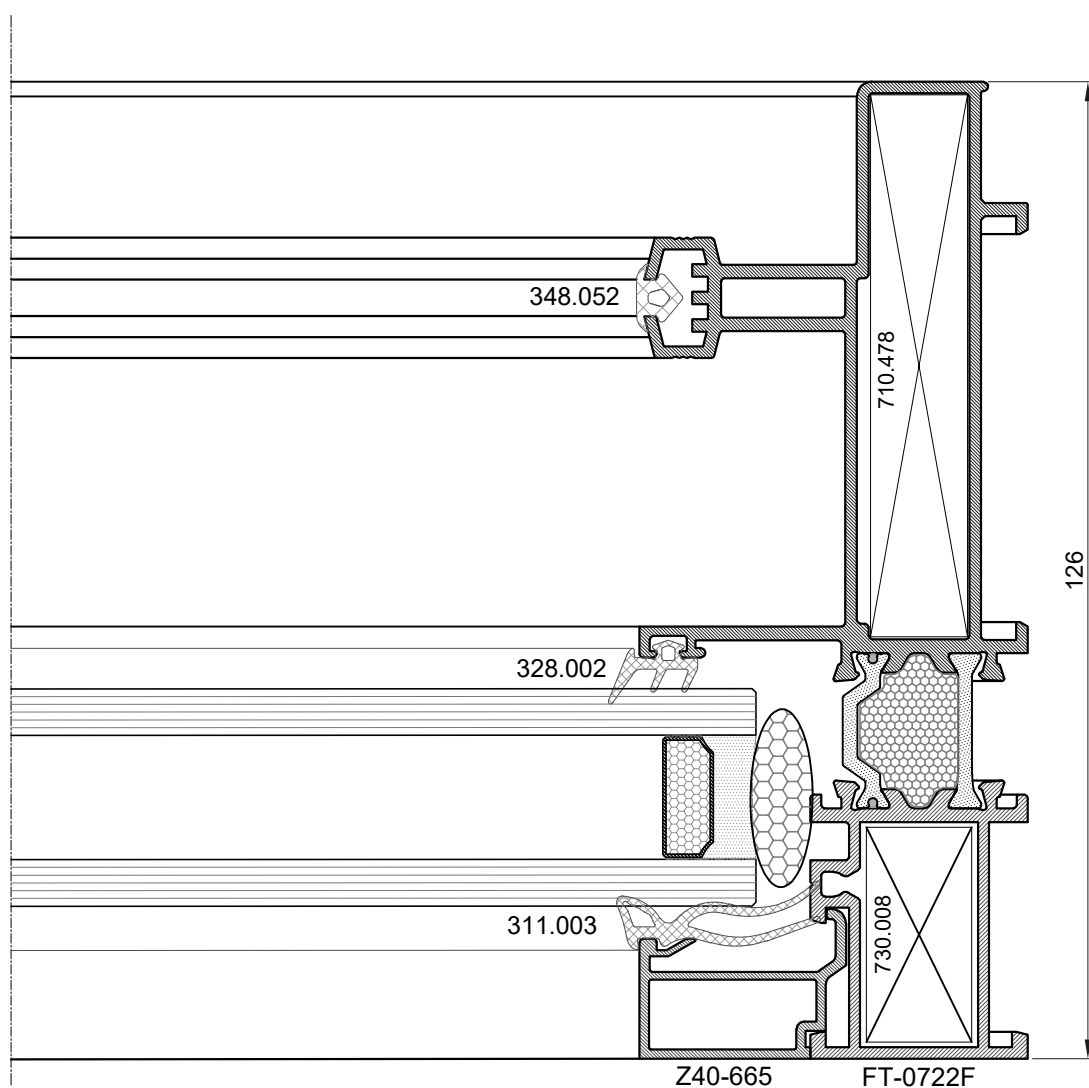
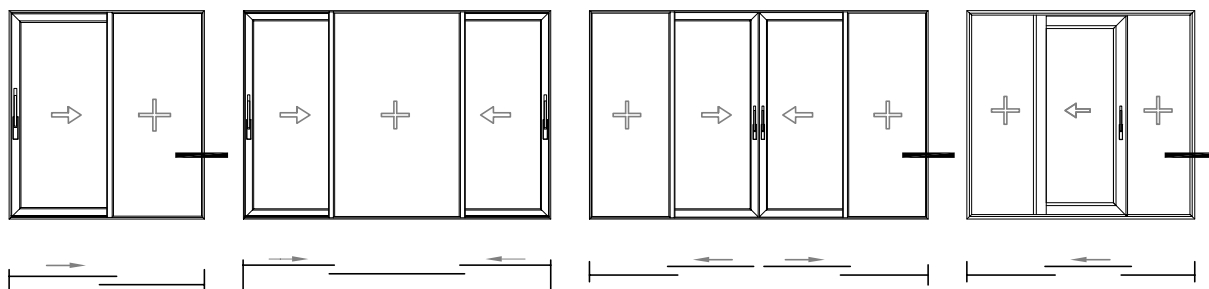

Presjeci s krilom FT-0725 podizno-klizno s integriranim fiksnim poljem

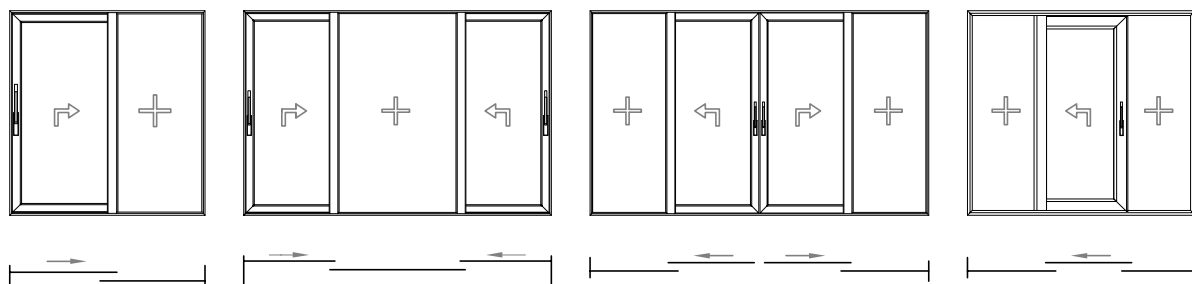

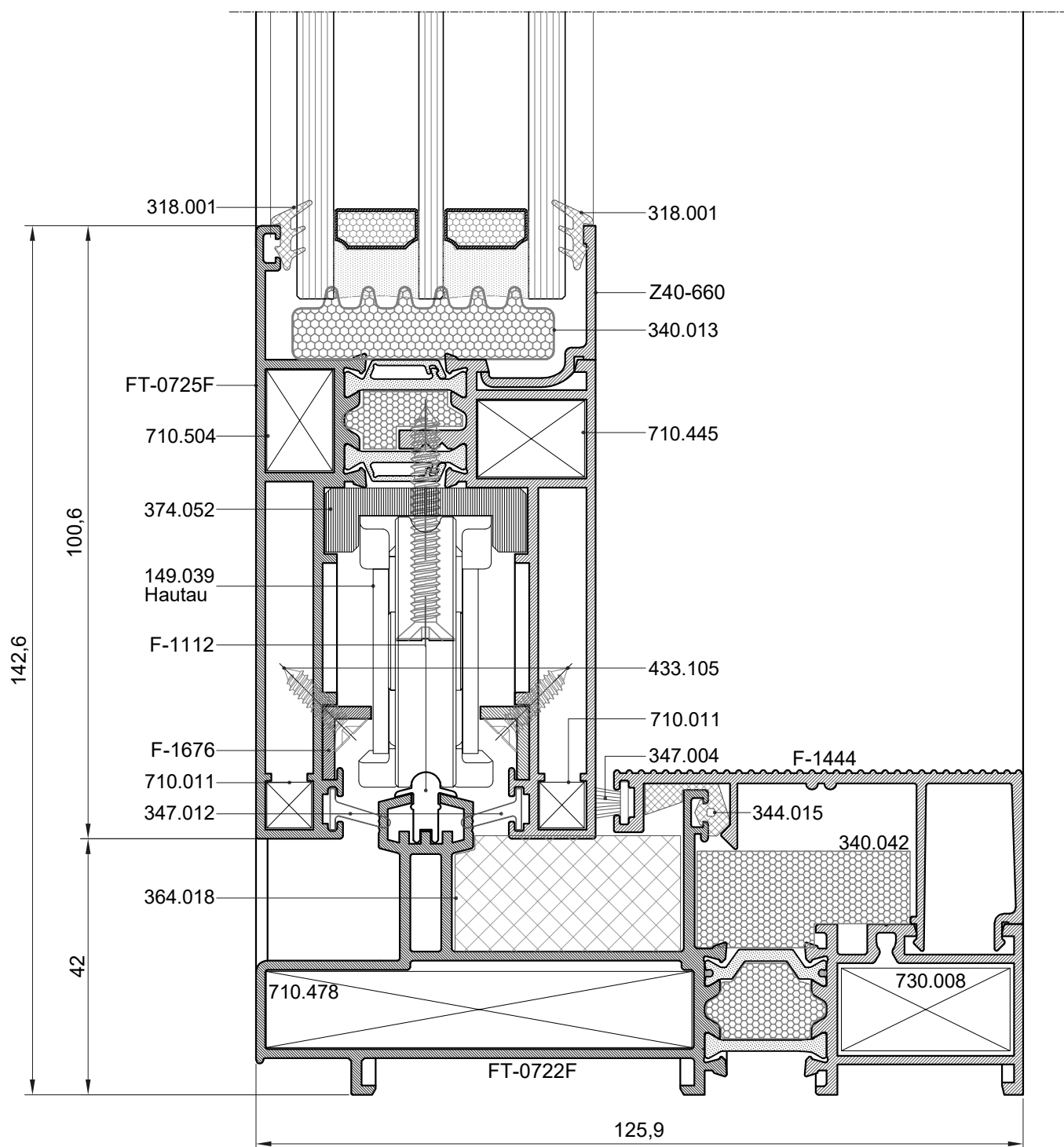
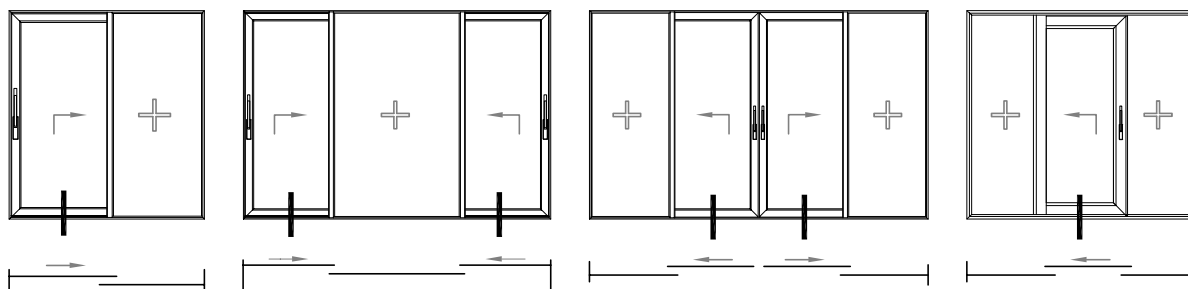

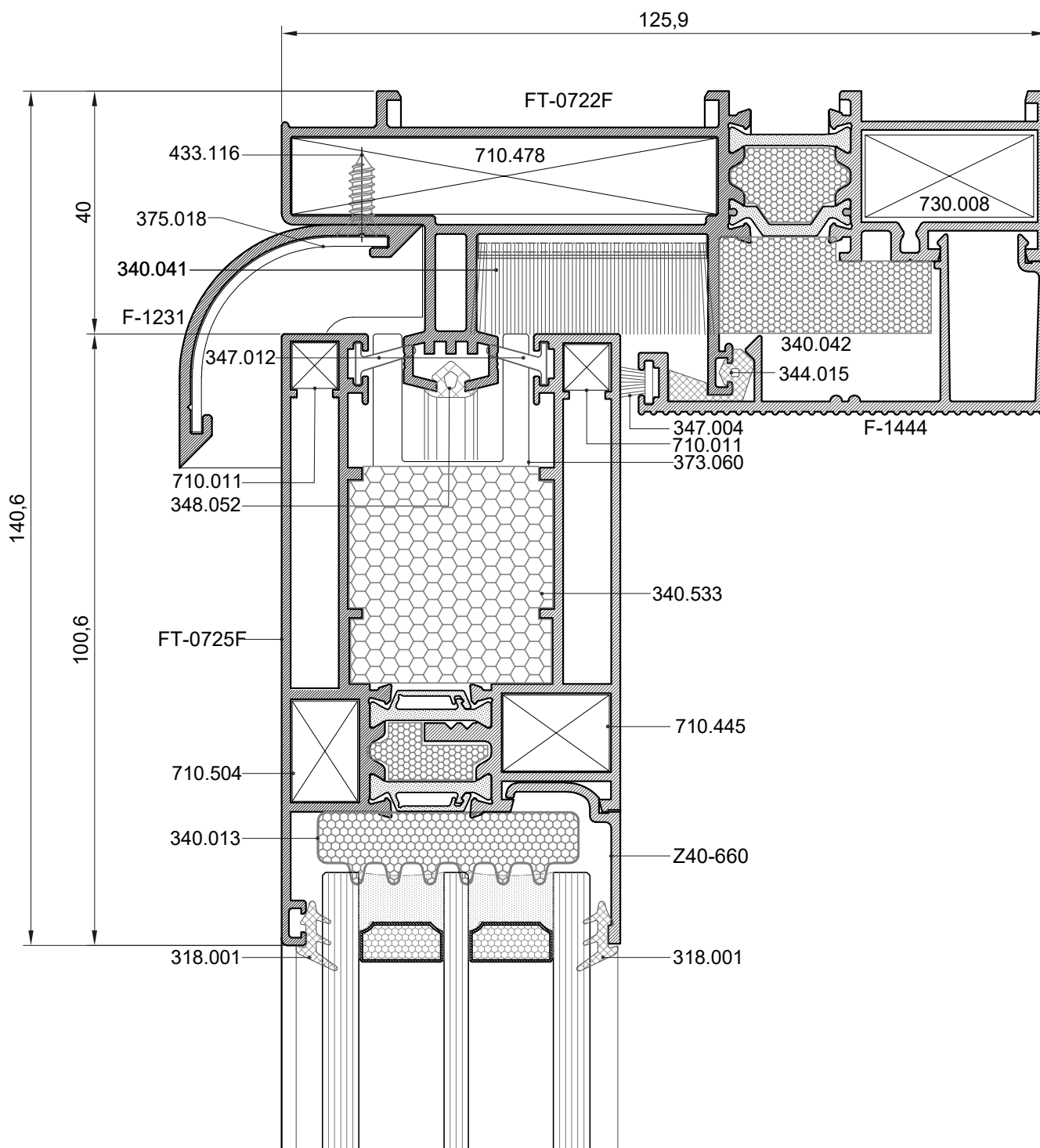
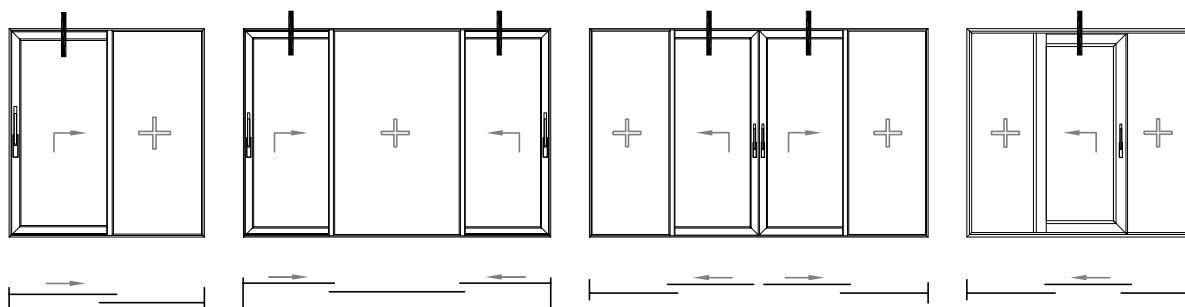

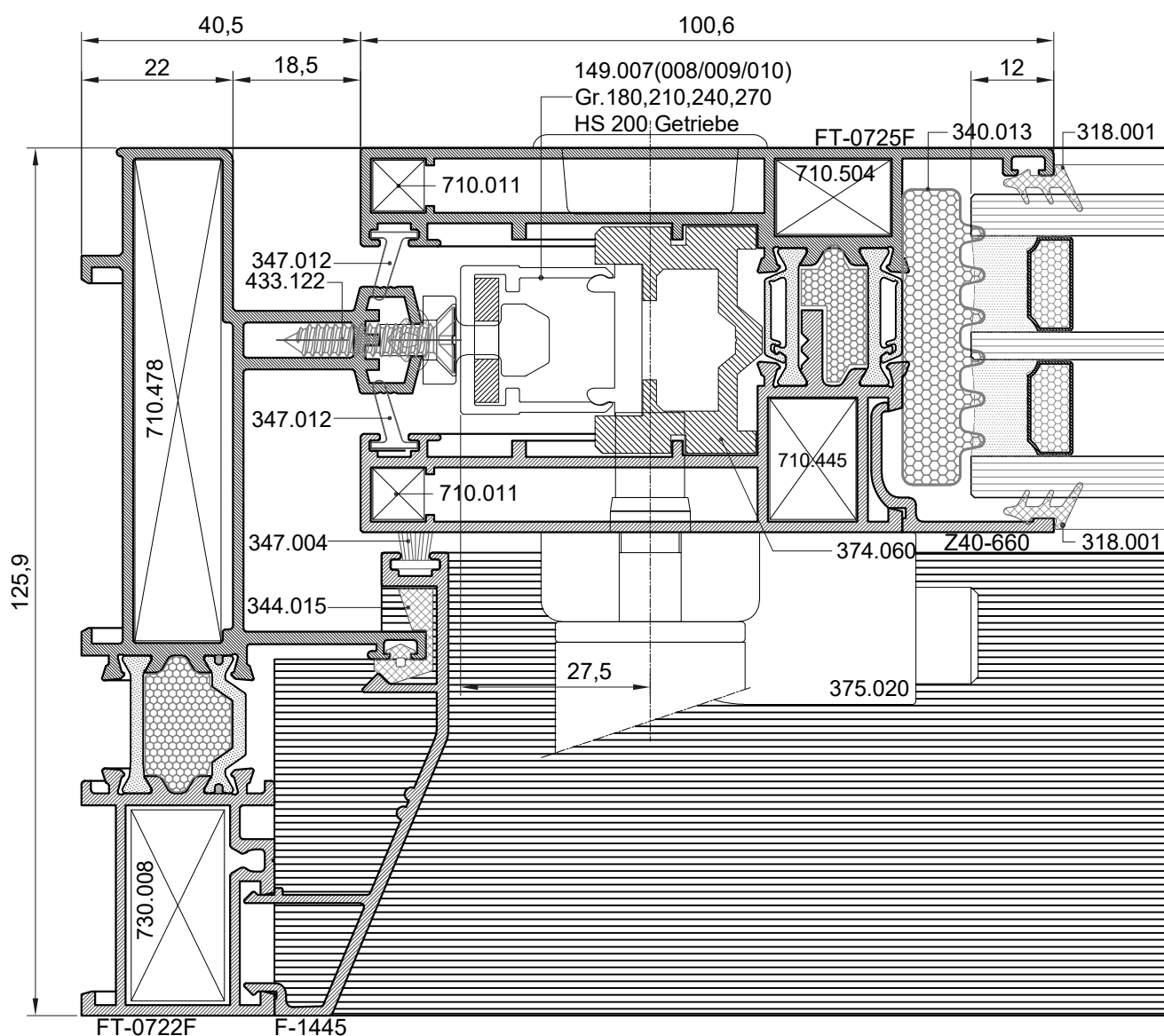
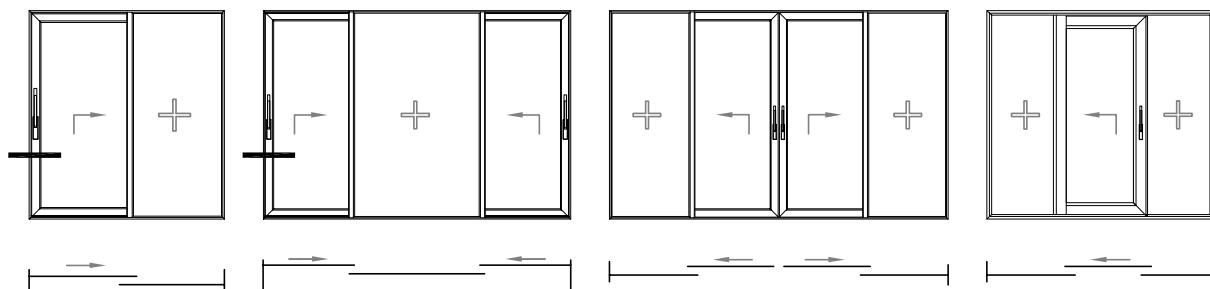

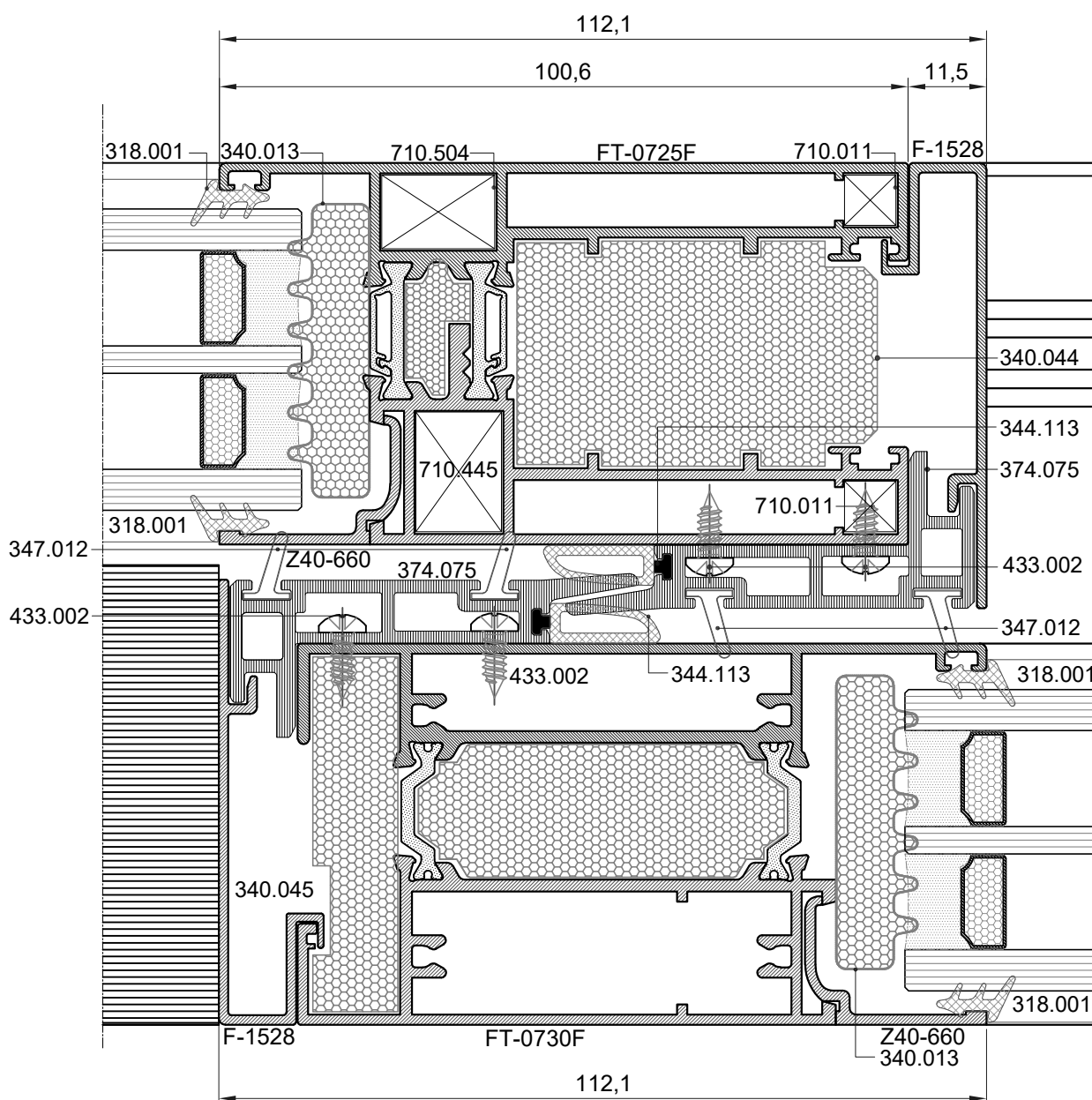
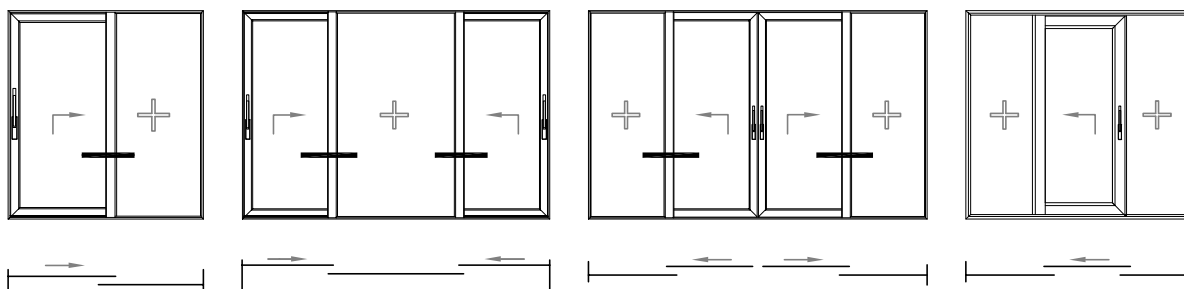

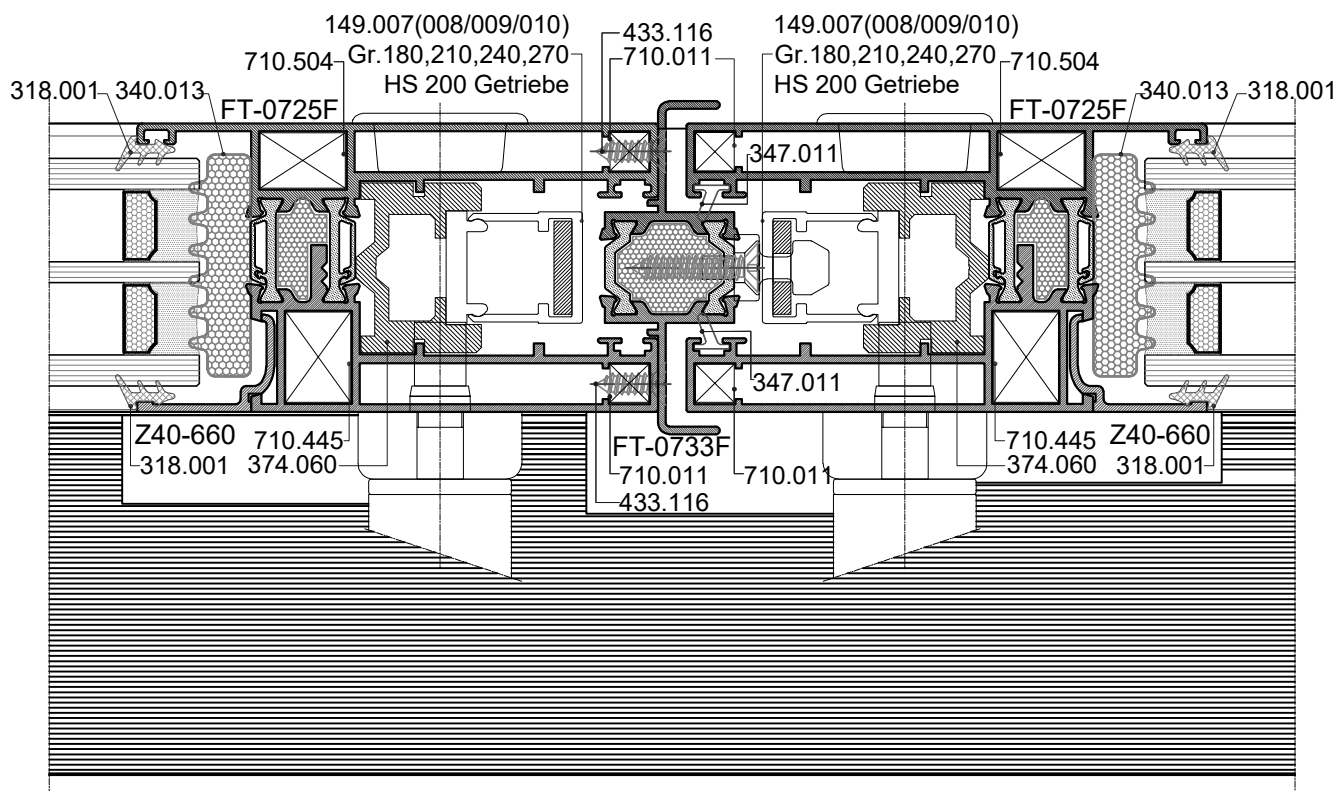
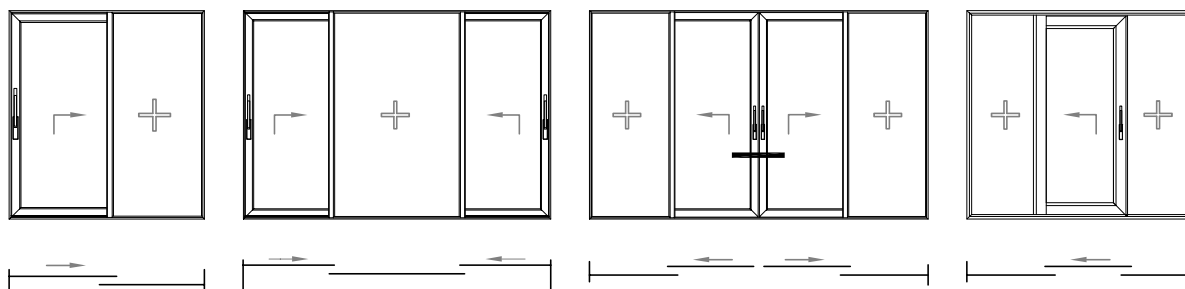

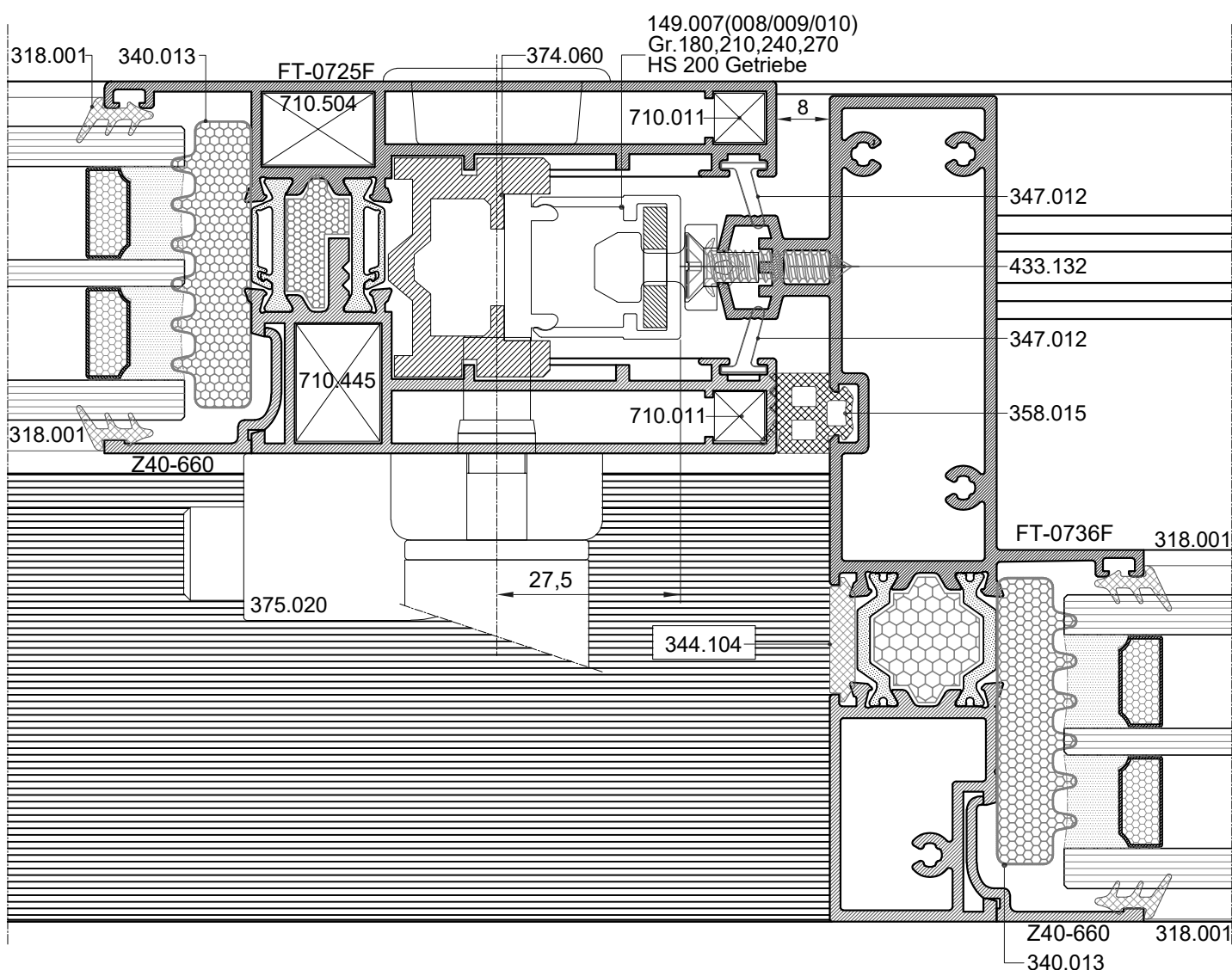
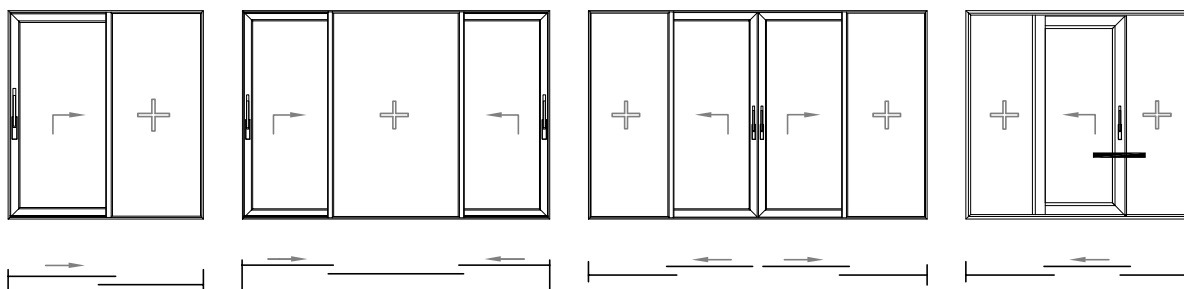

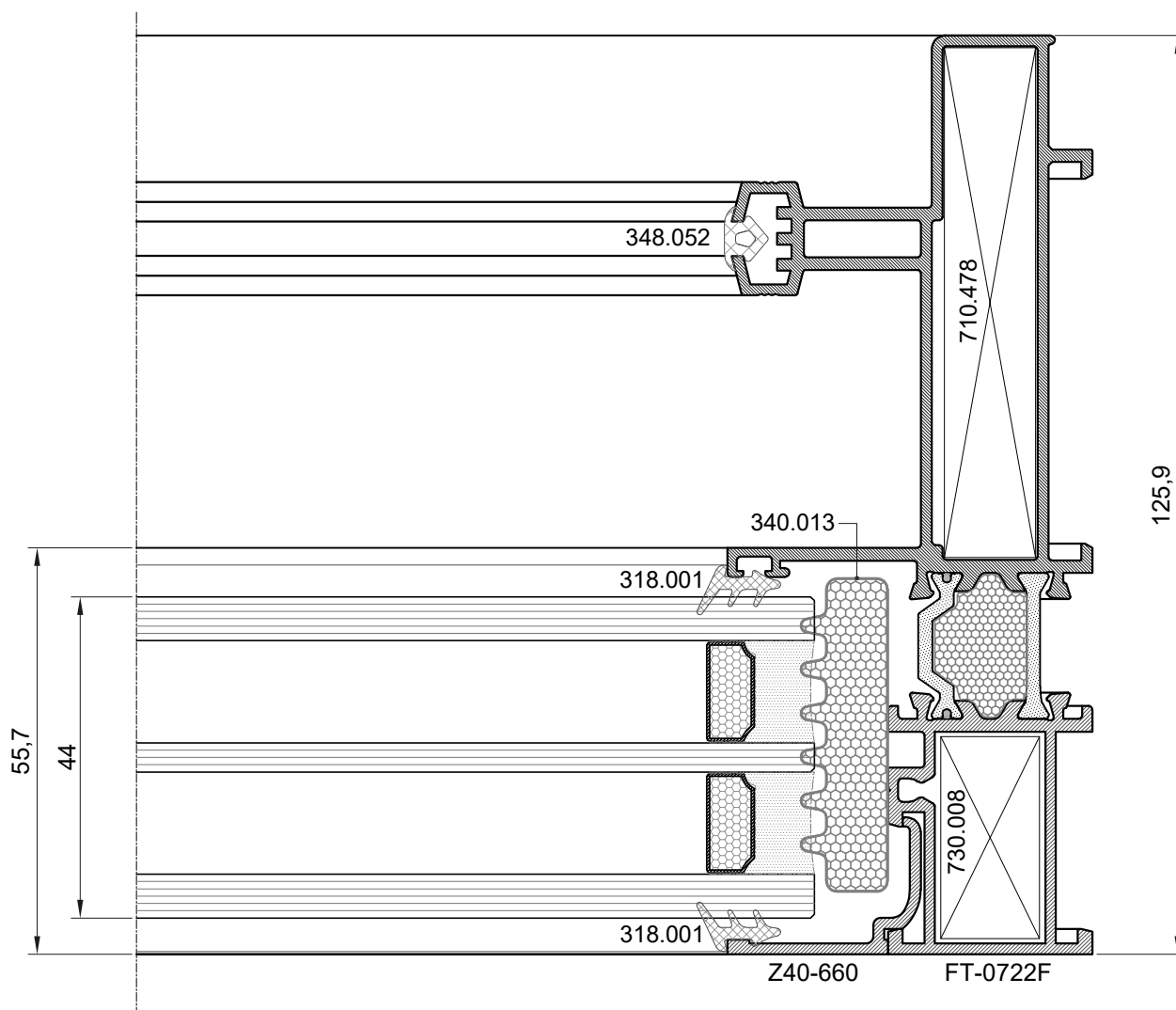
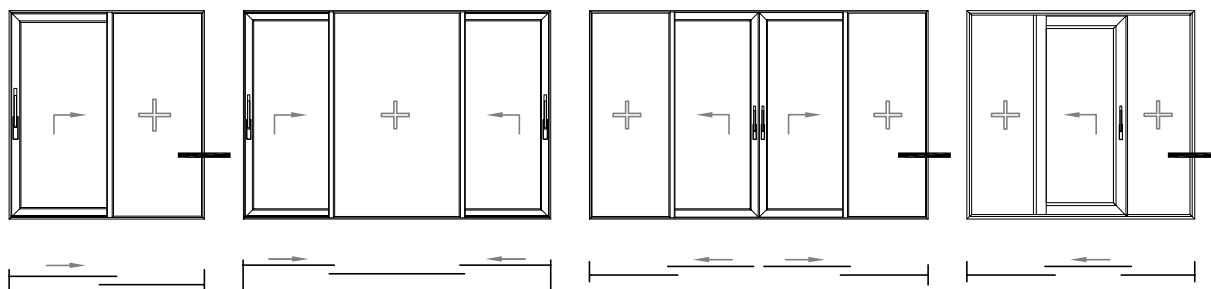

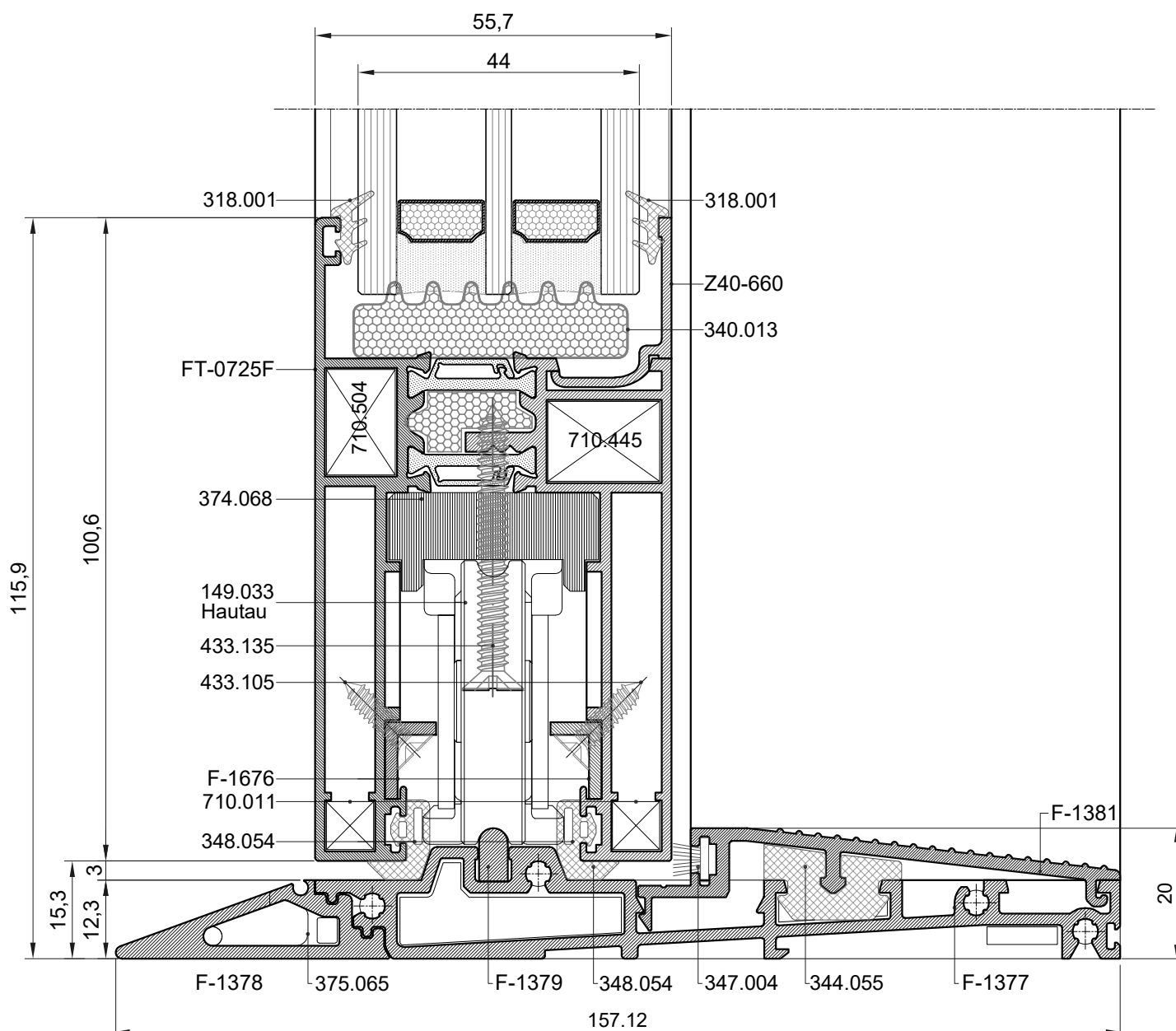
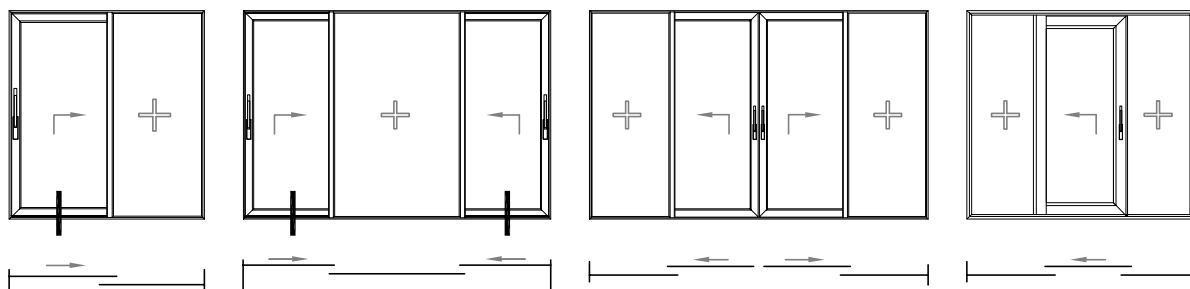

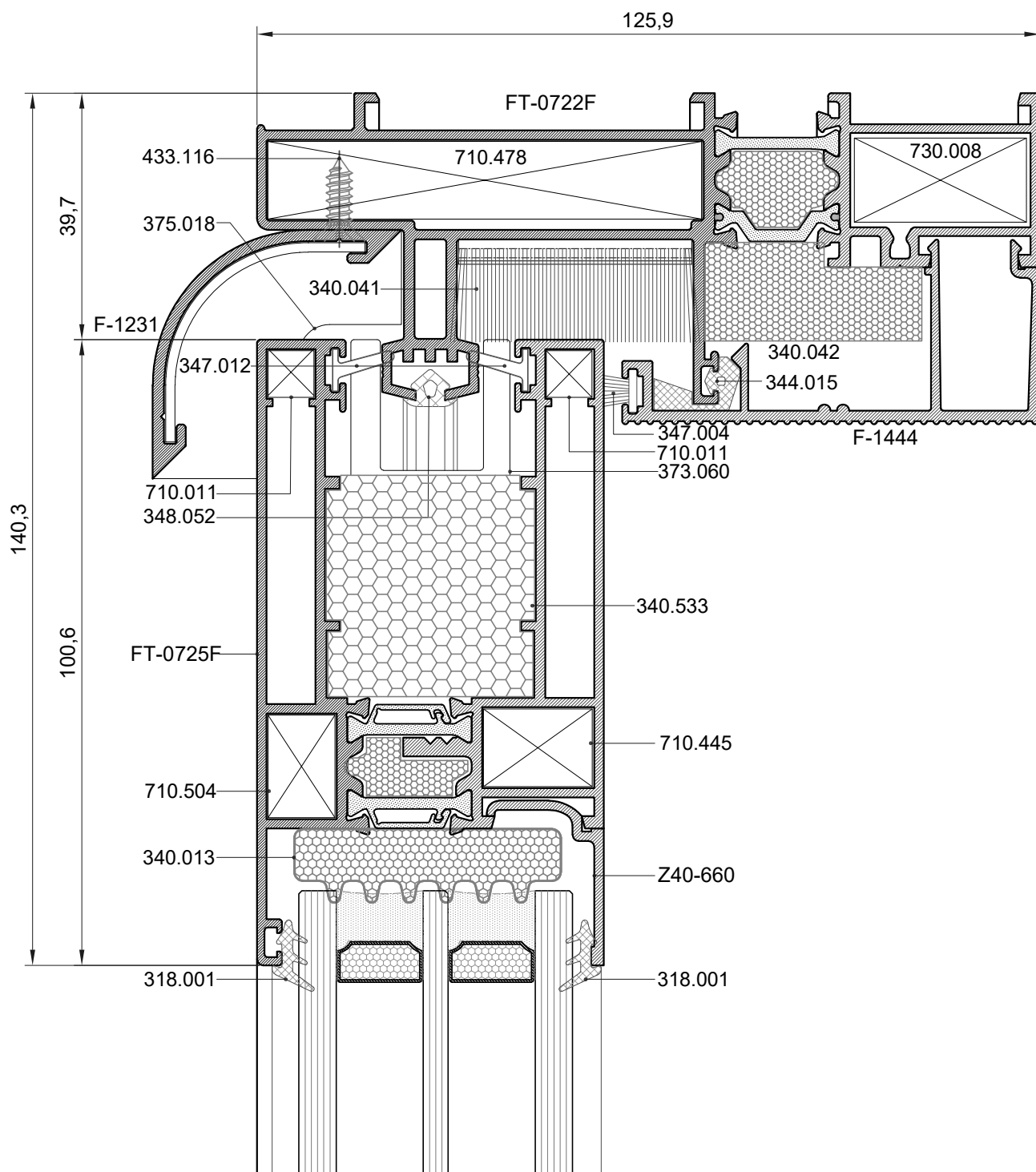
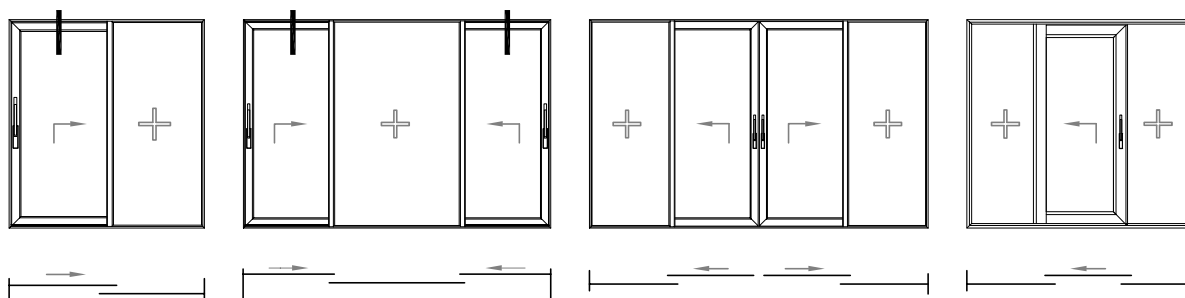

Gornji detalj presjeka s niskim pragom
Upper section detail with low threshold

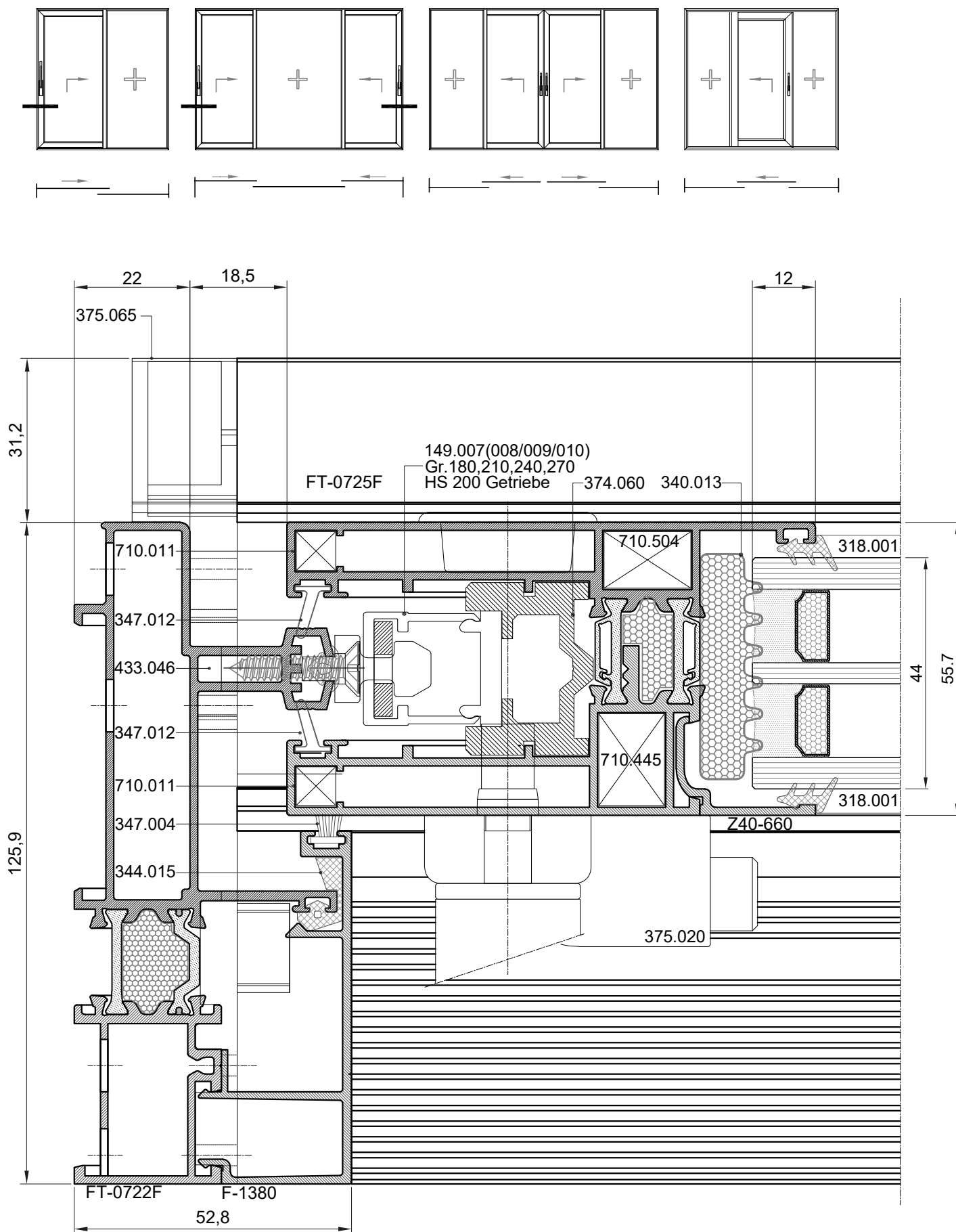

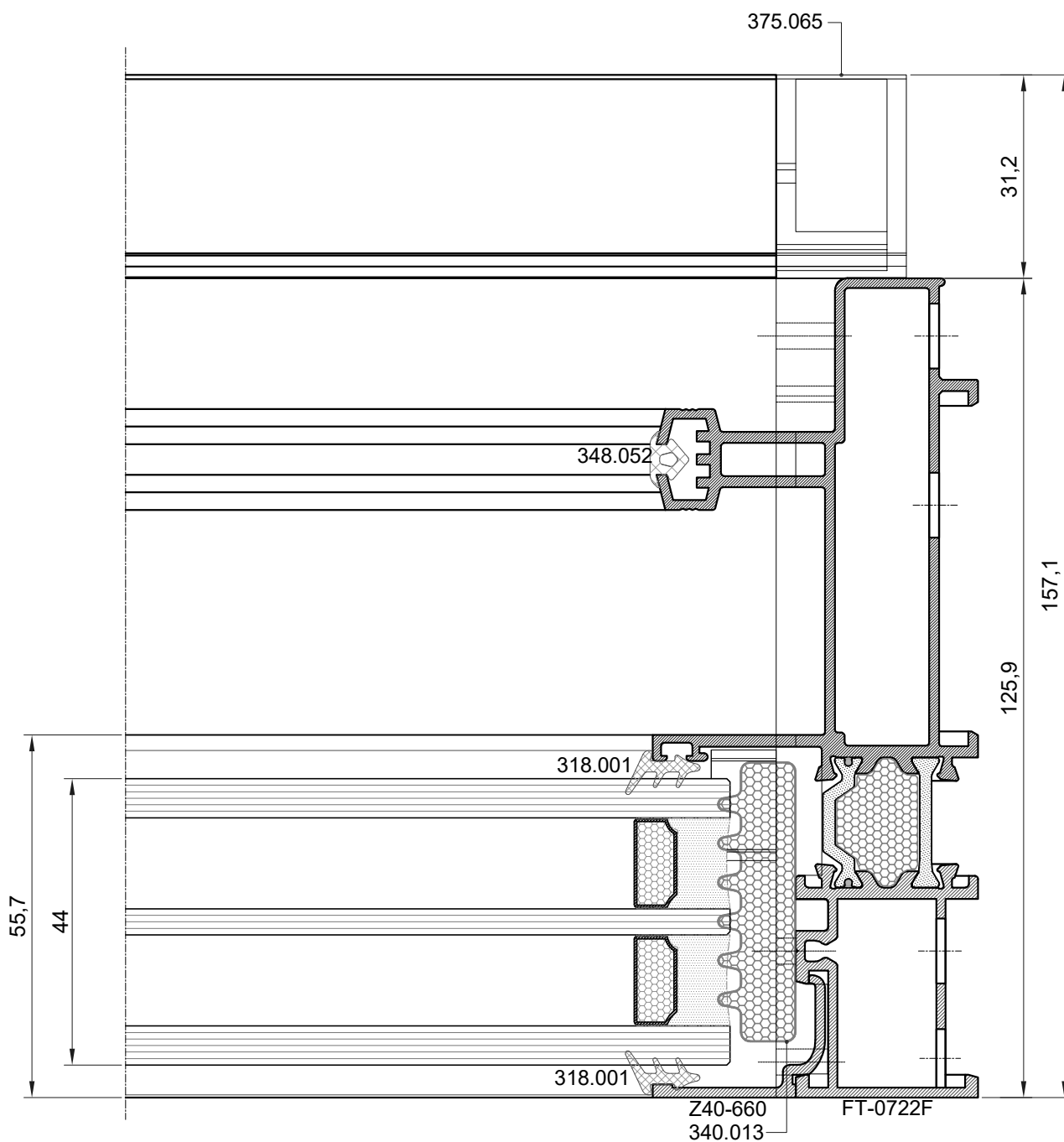
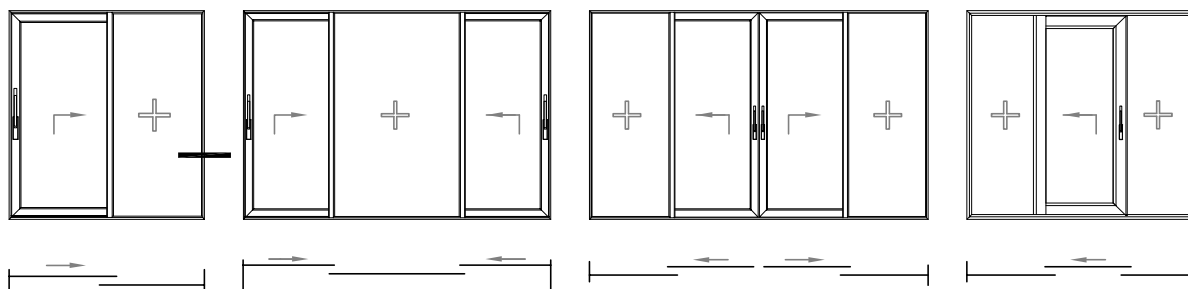

Presjeci s krilom FT-0727 podizno-klizno s integriranim fisknim poljem

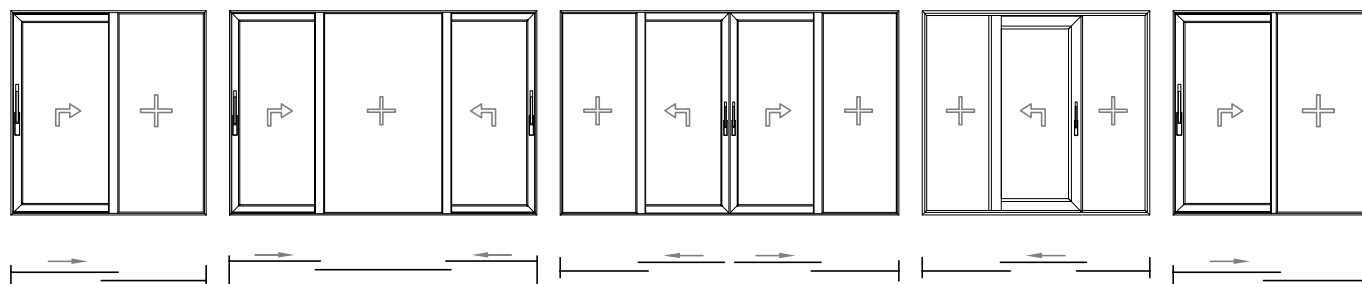

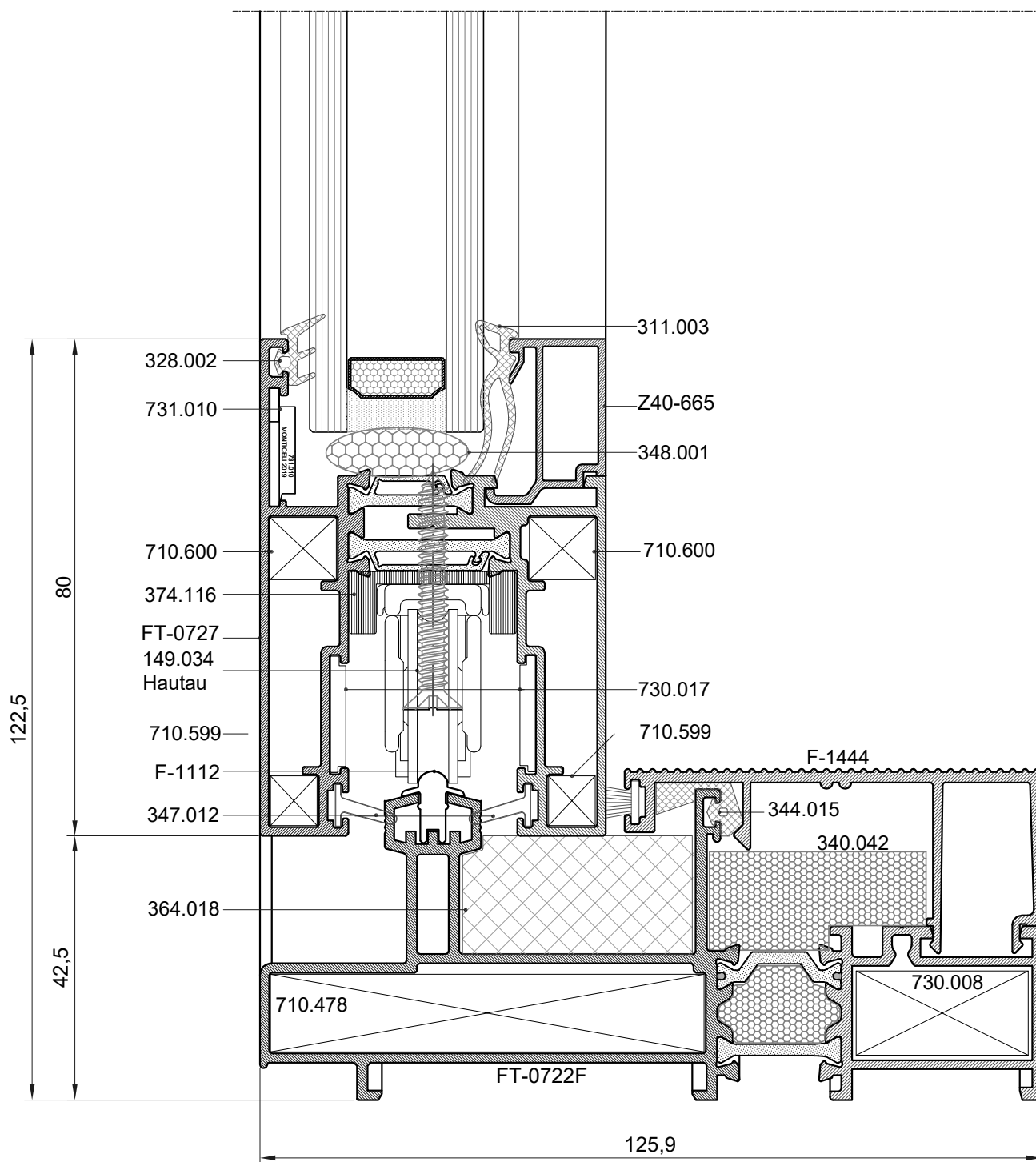
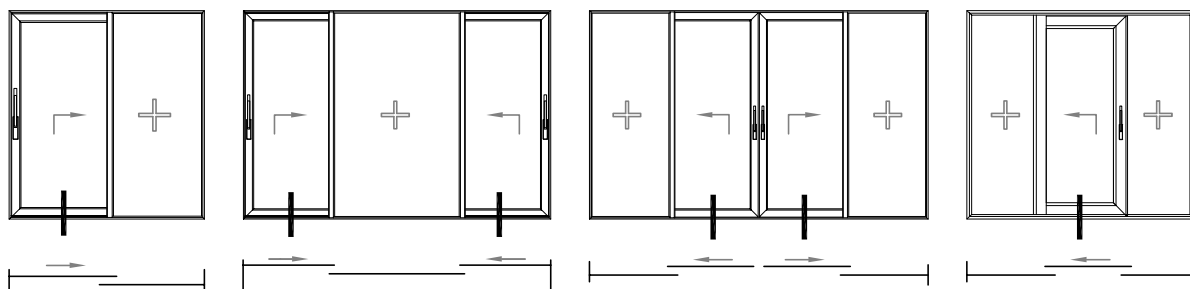

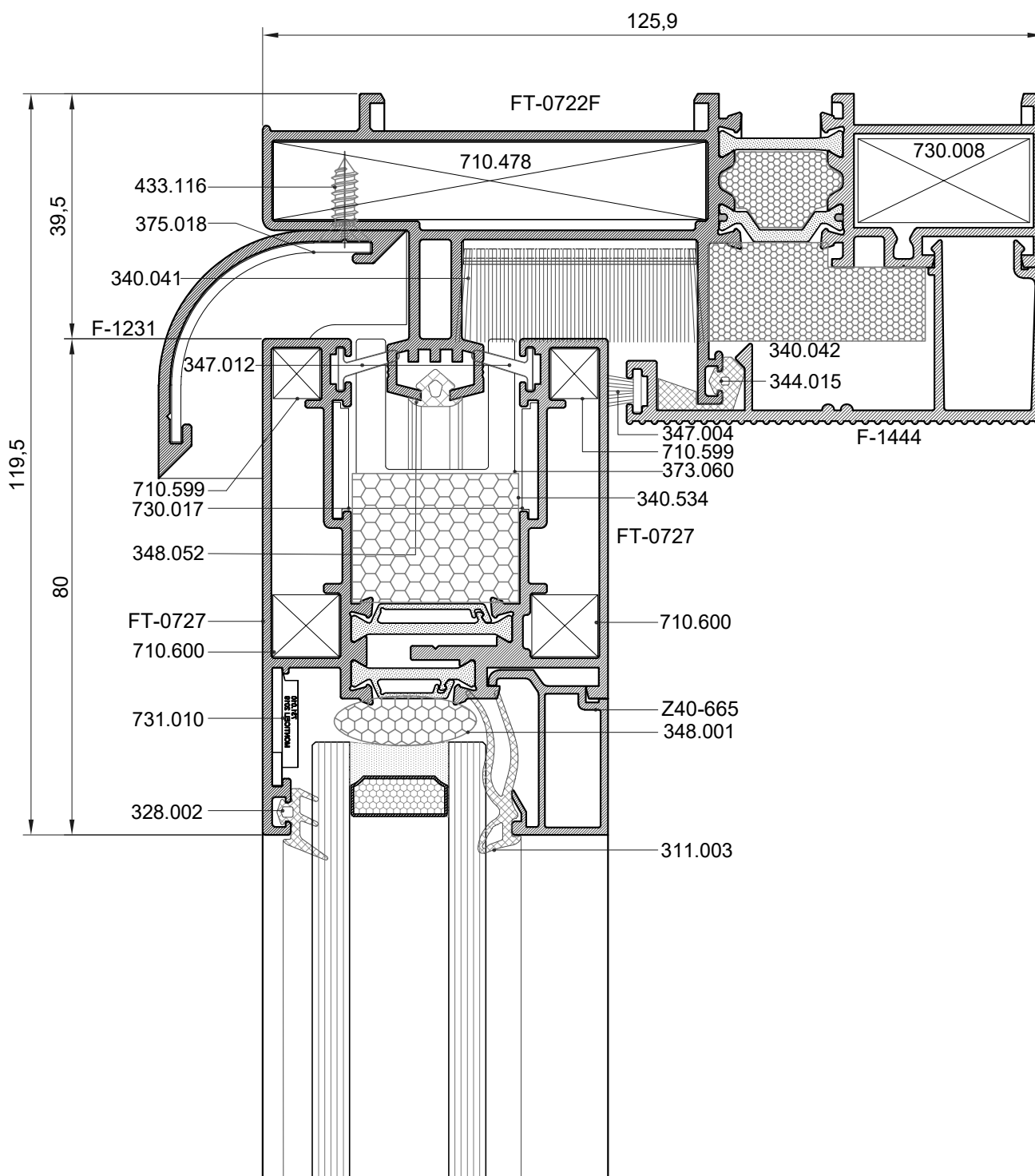
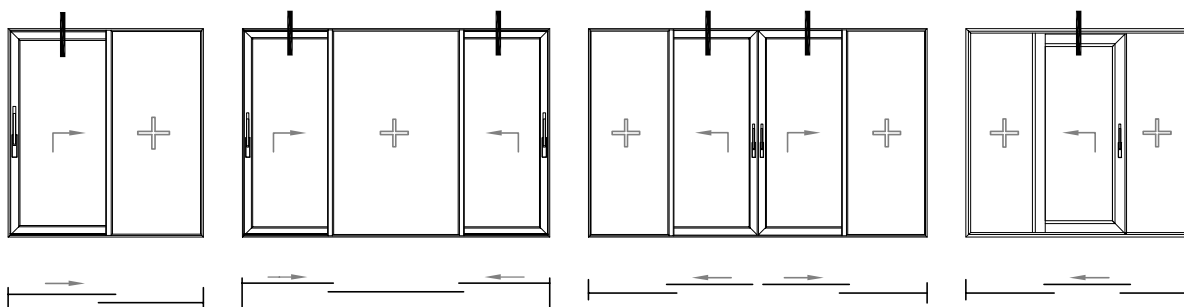

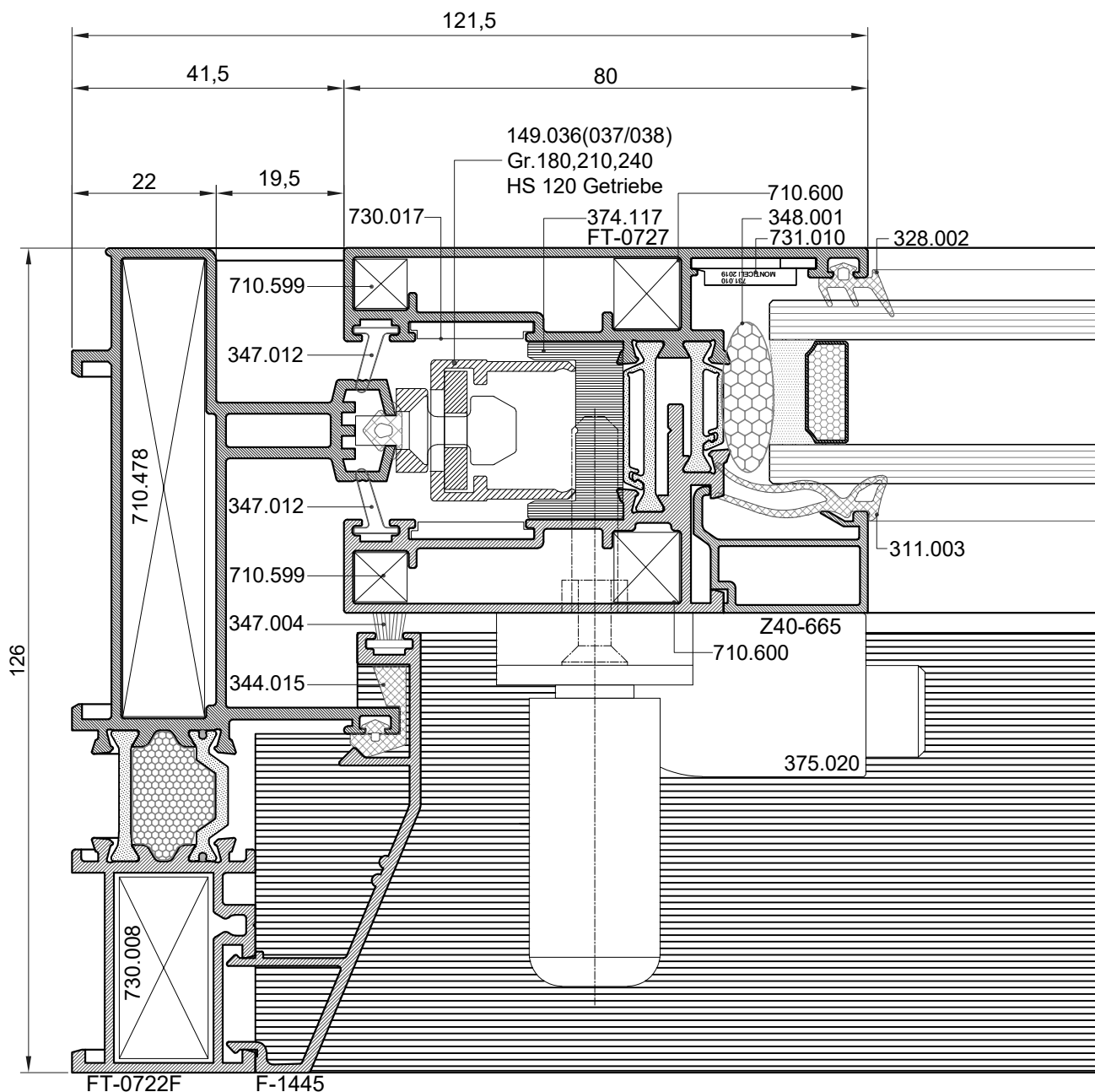
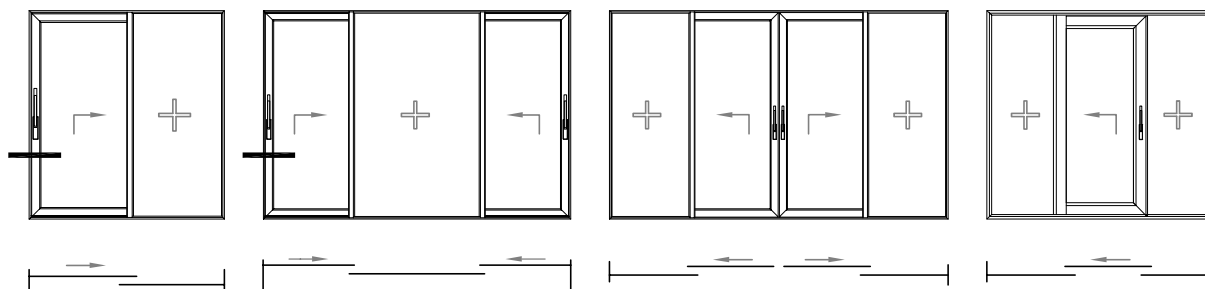

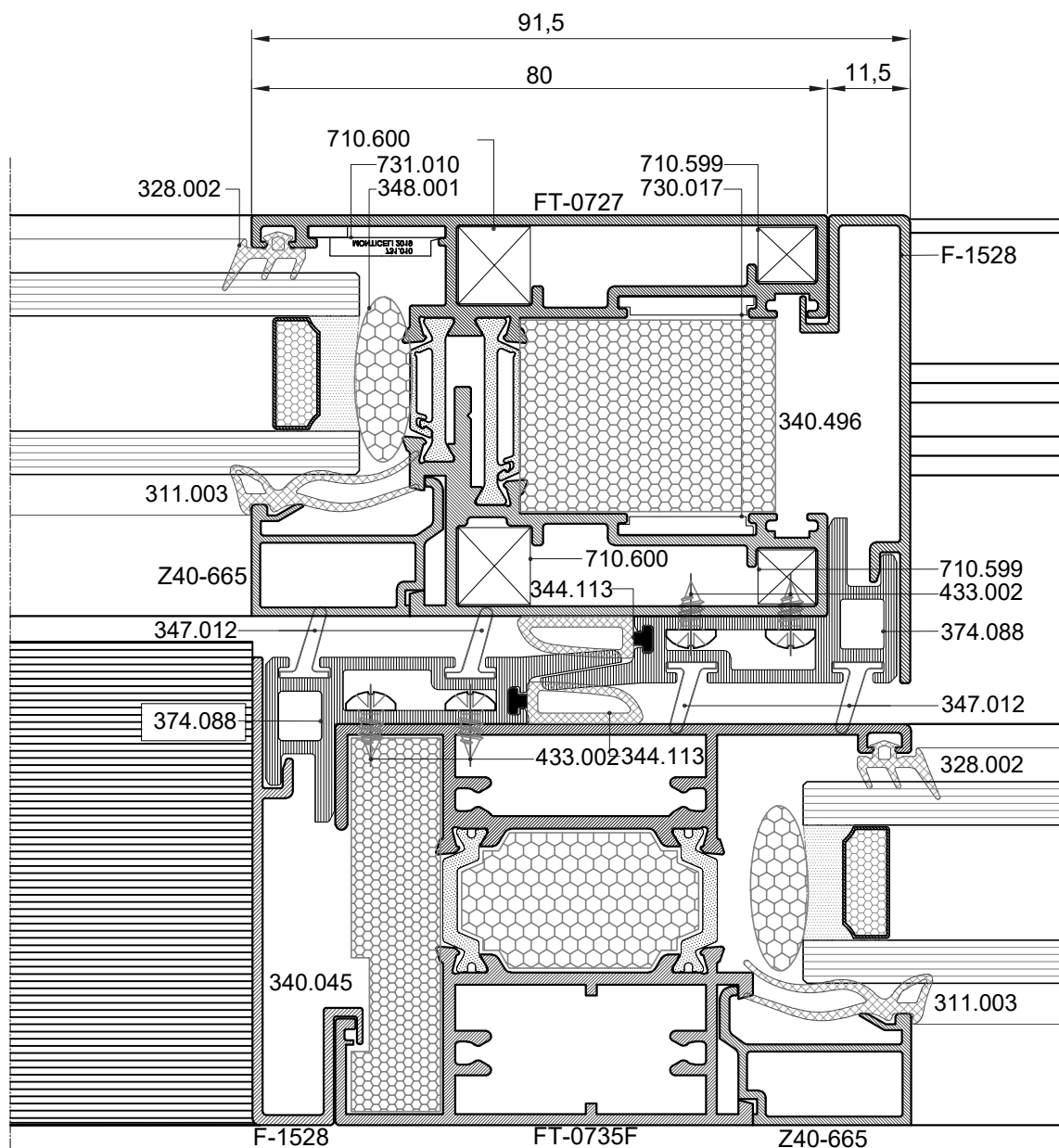
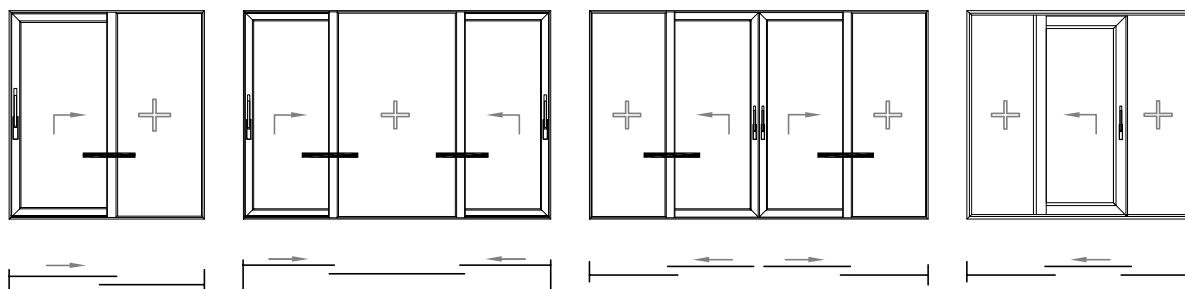

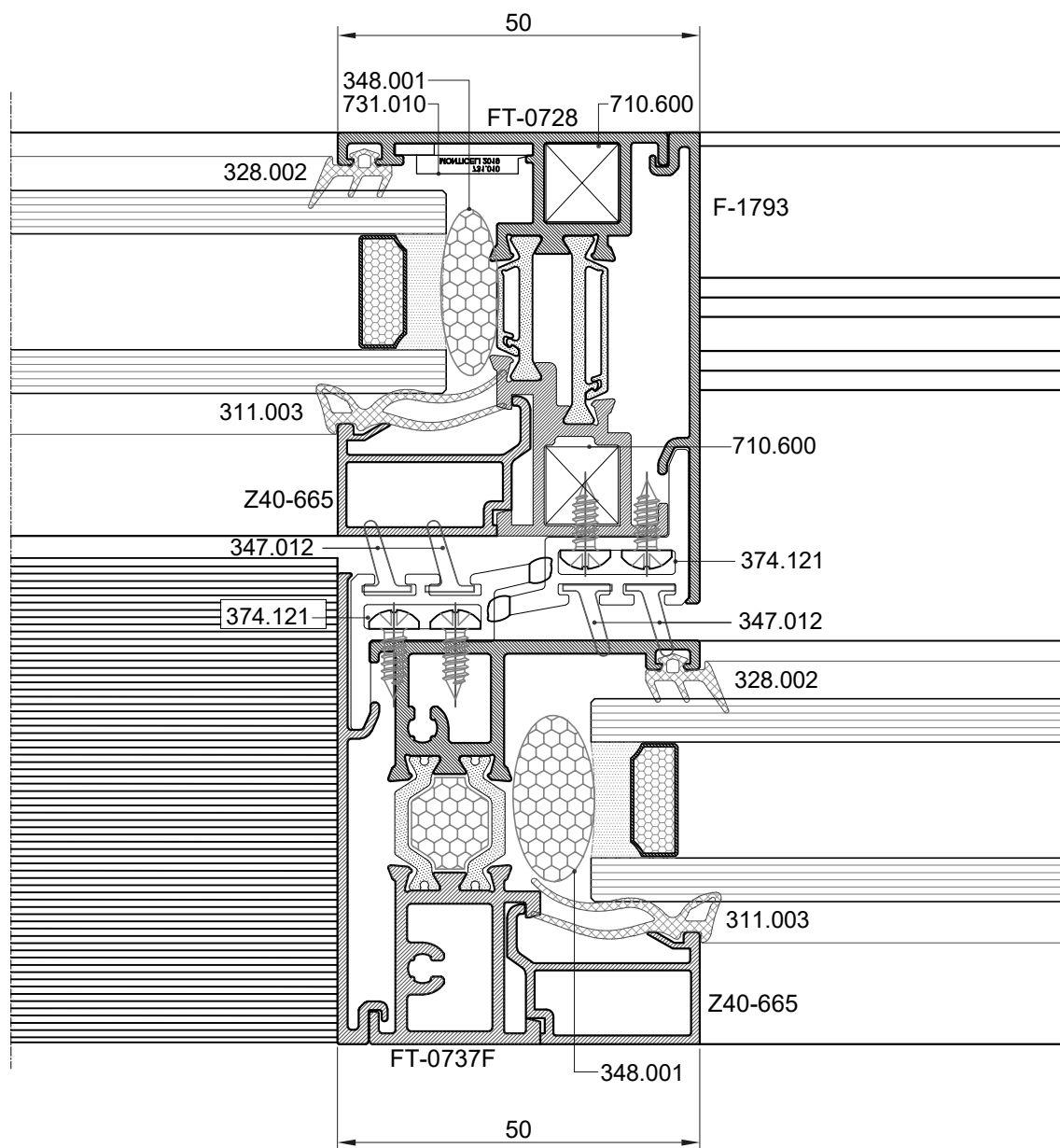
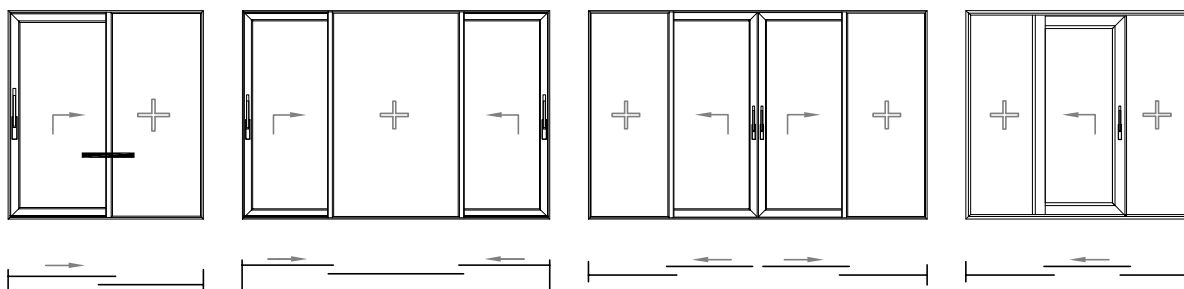

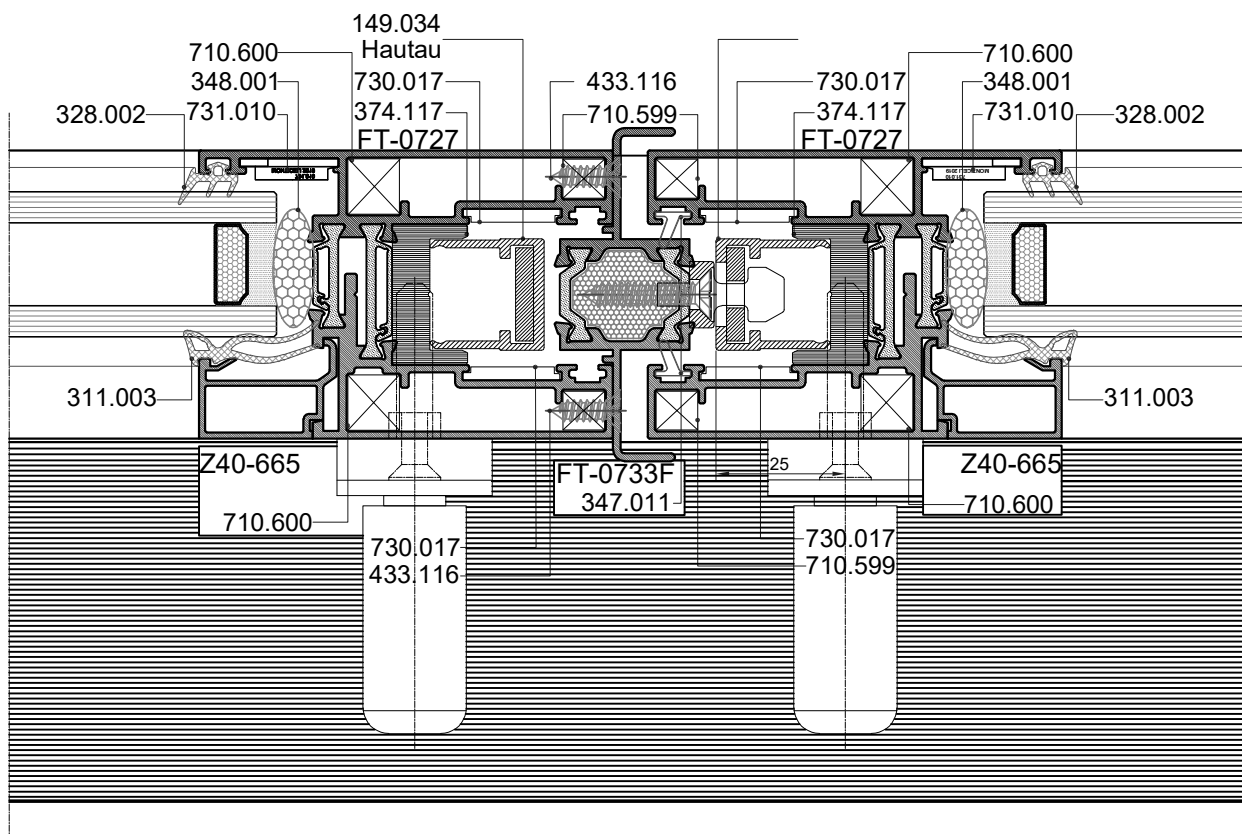
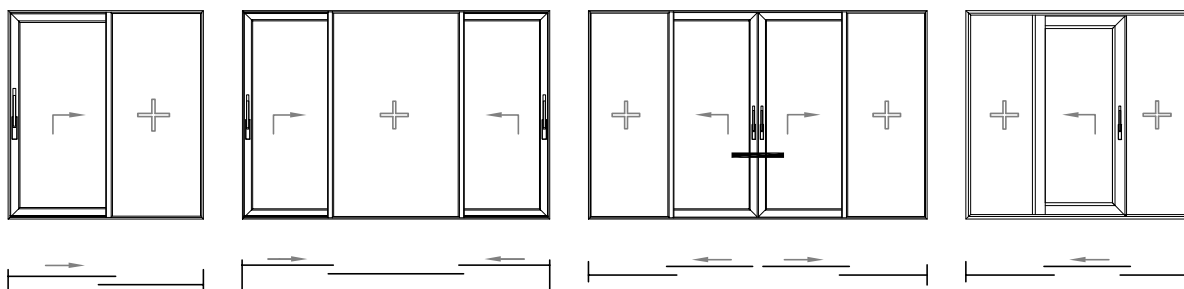

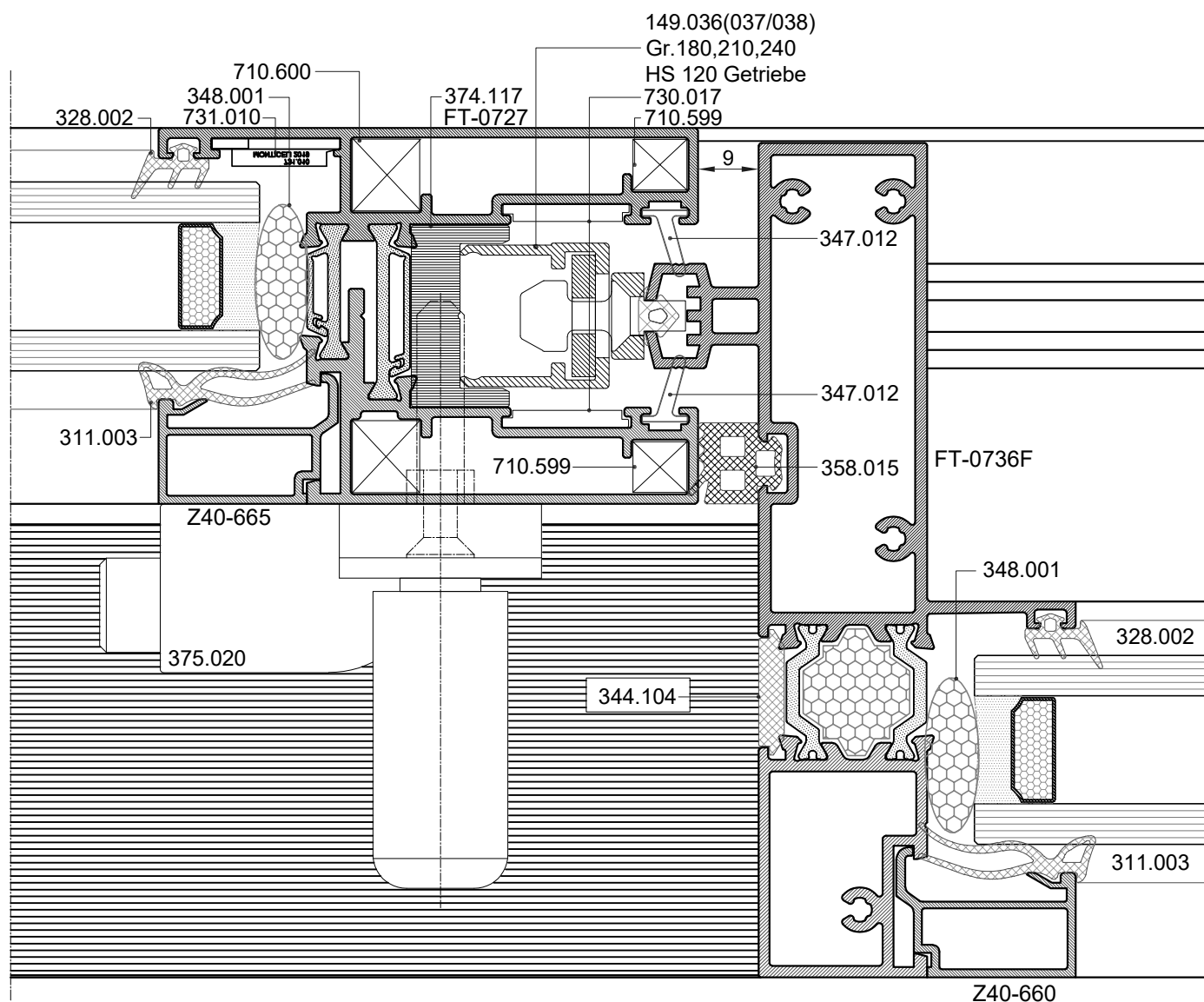
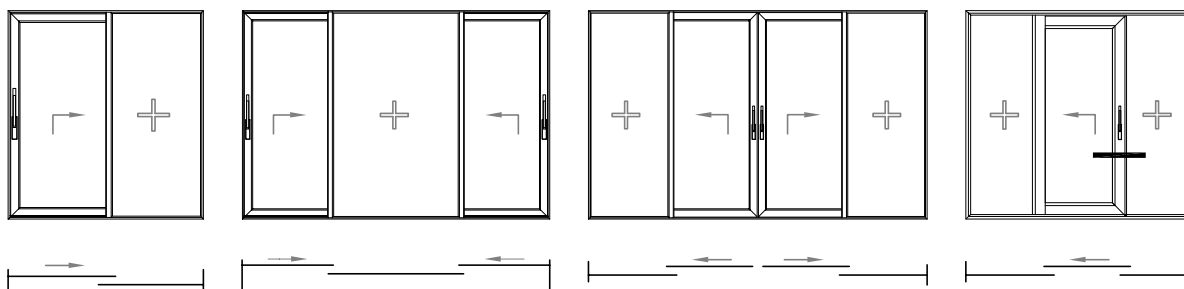

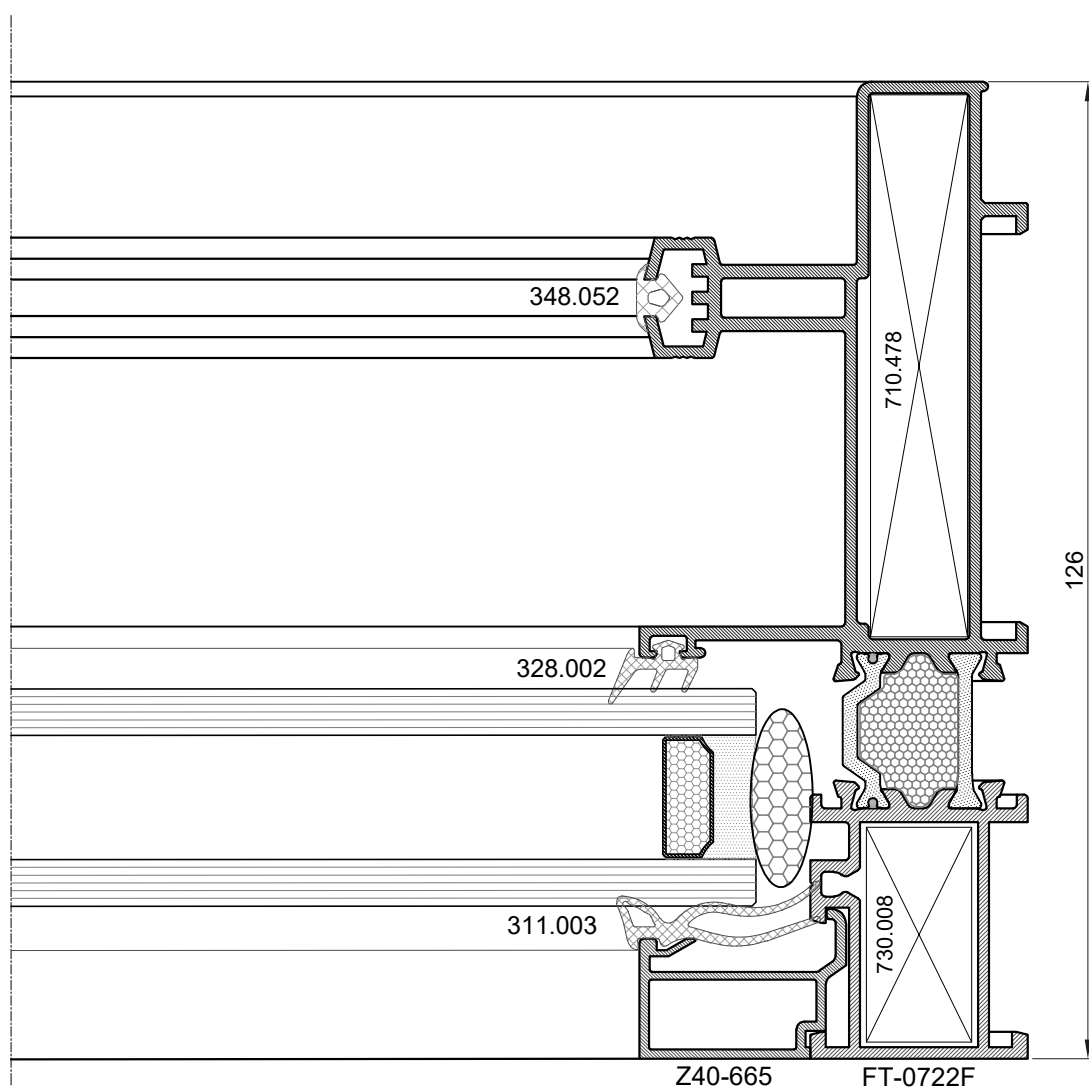
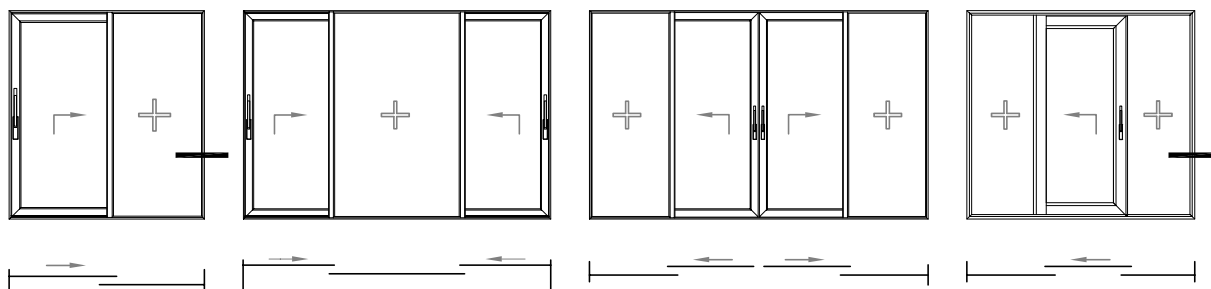

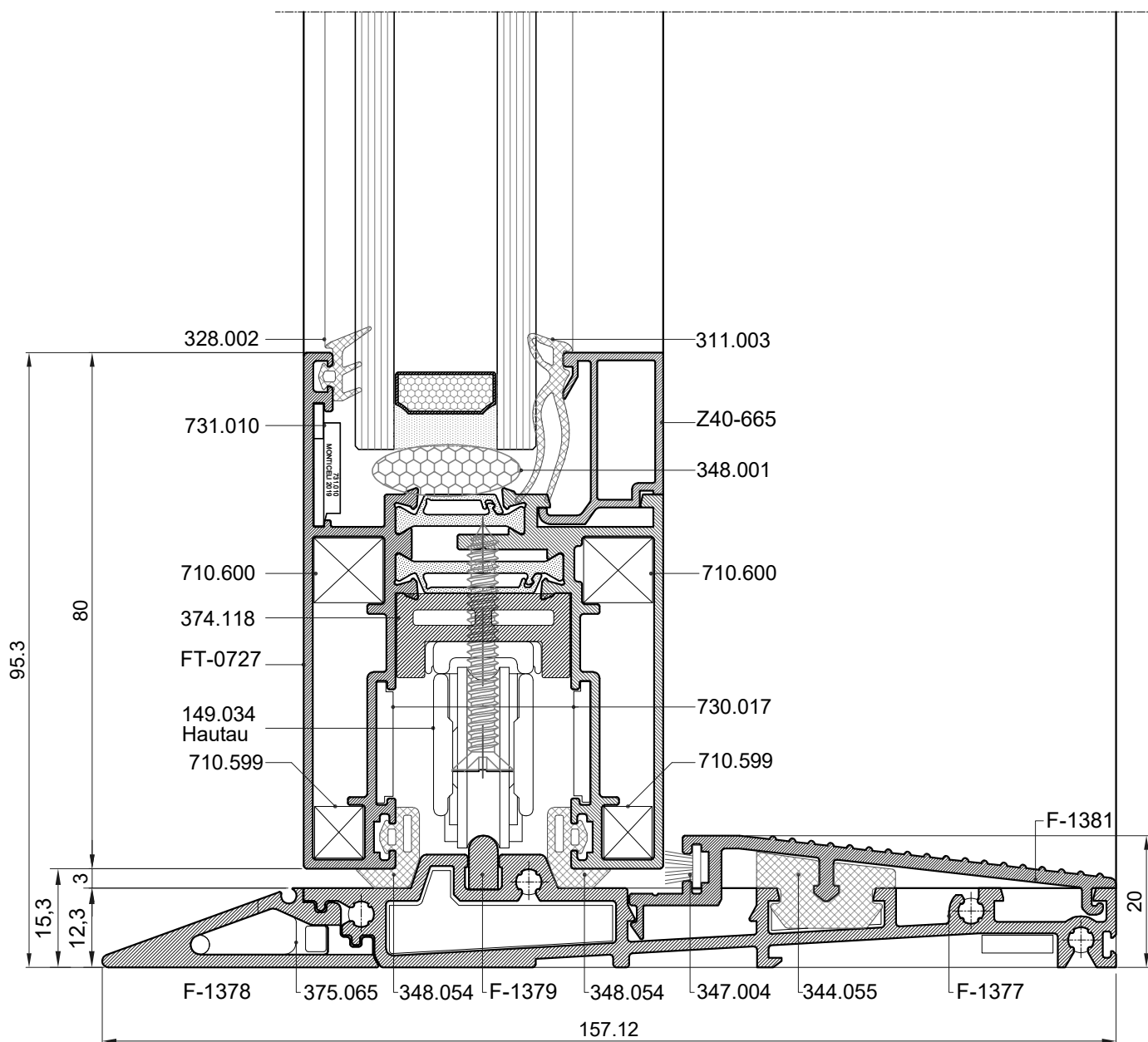
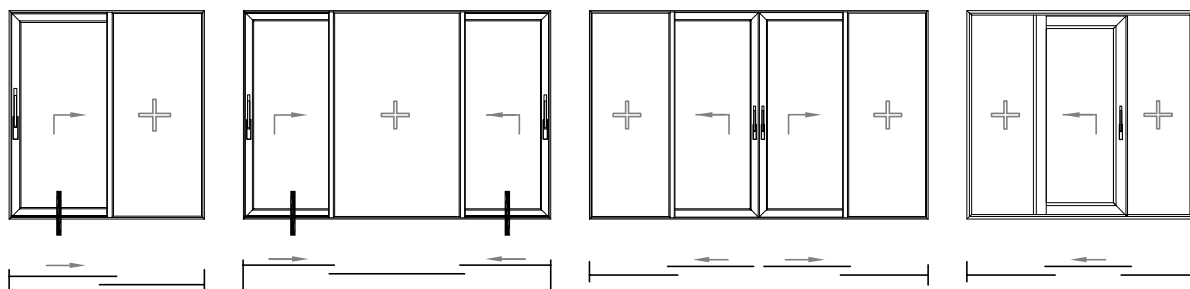

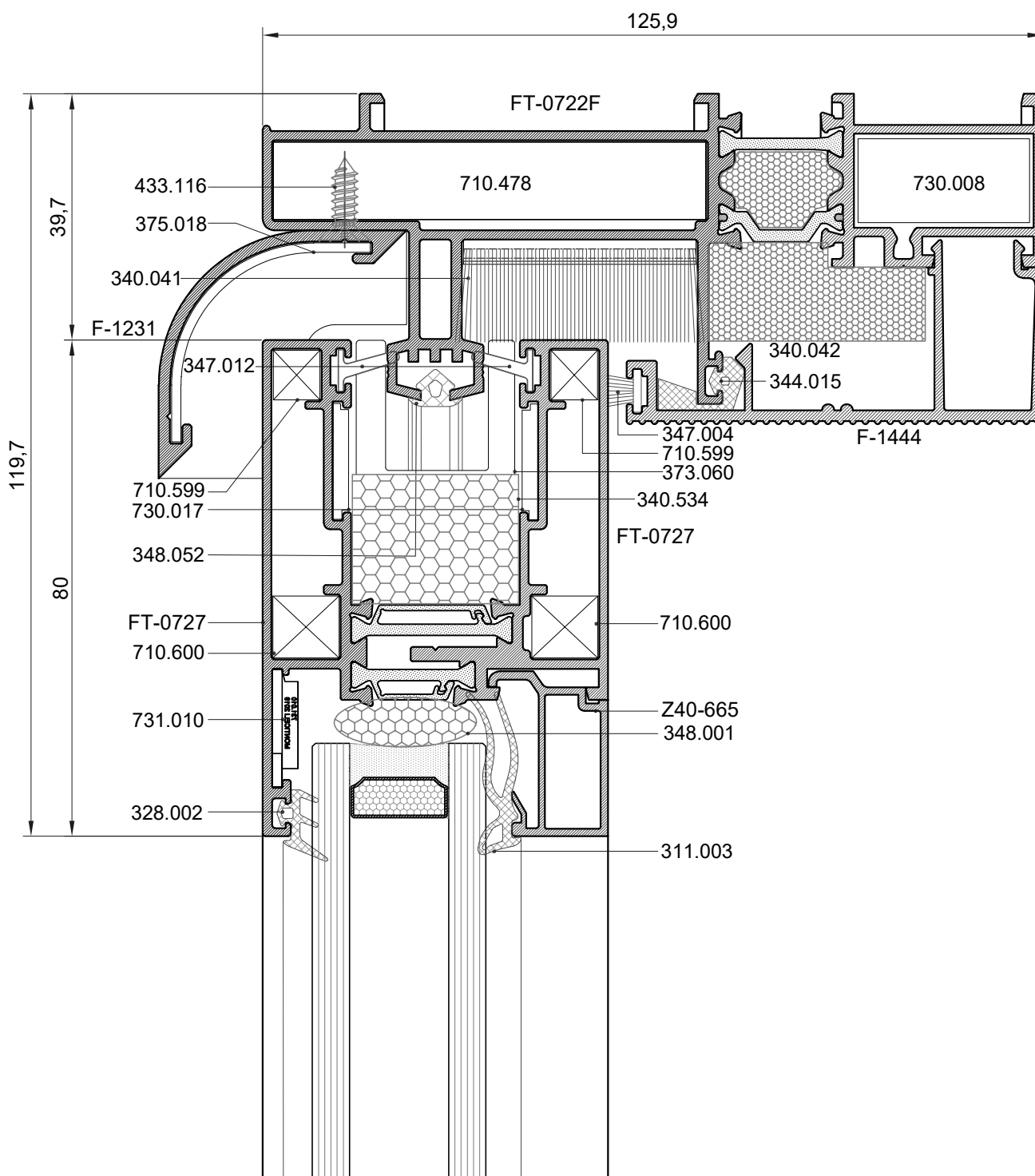
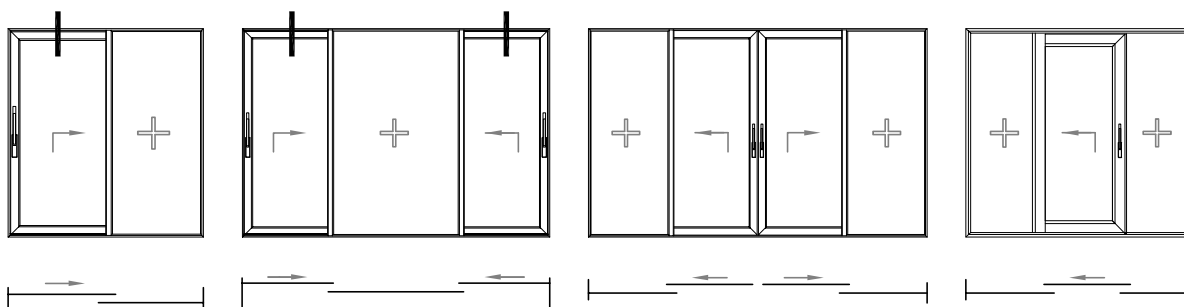

Gornji detalj presjeka s niskim pragom
Upper section detail with low threshold

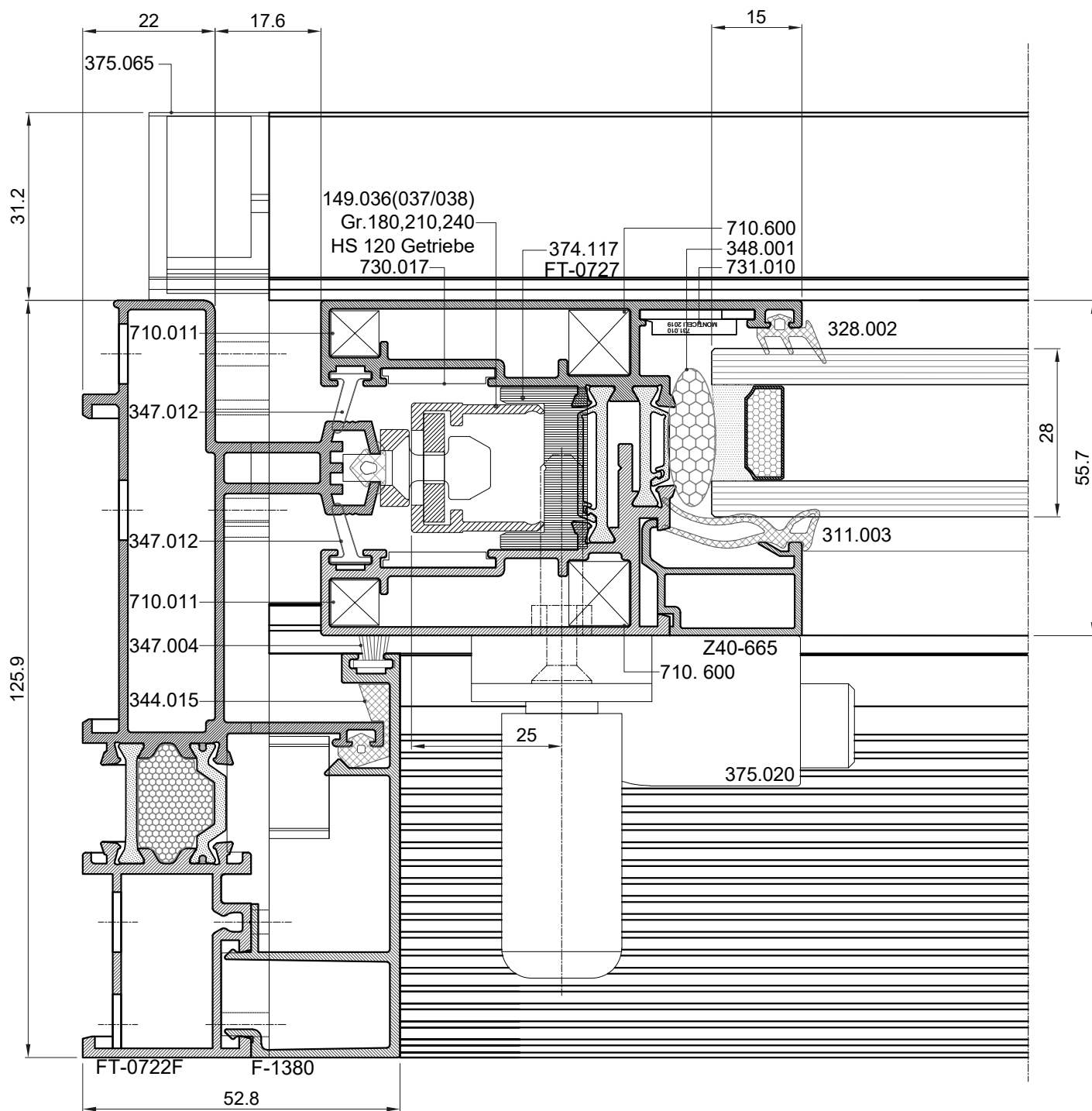
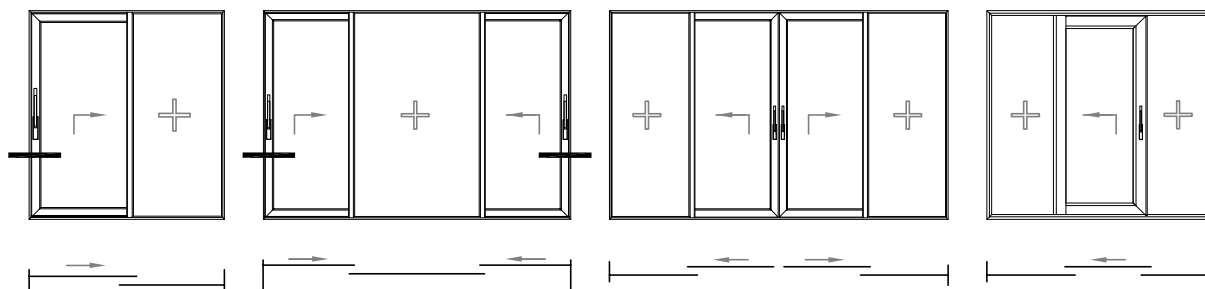

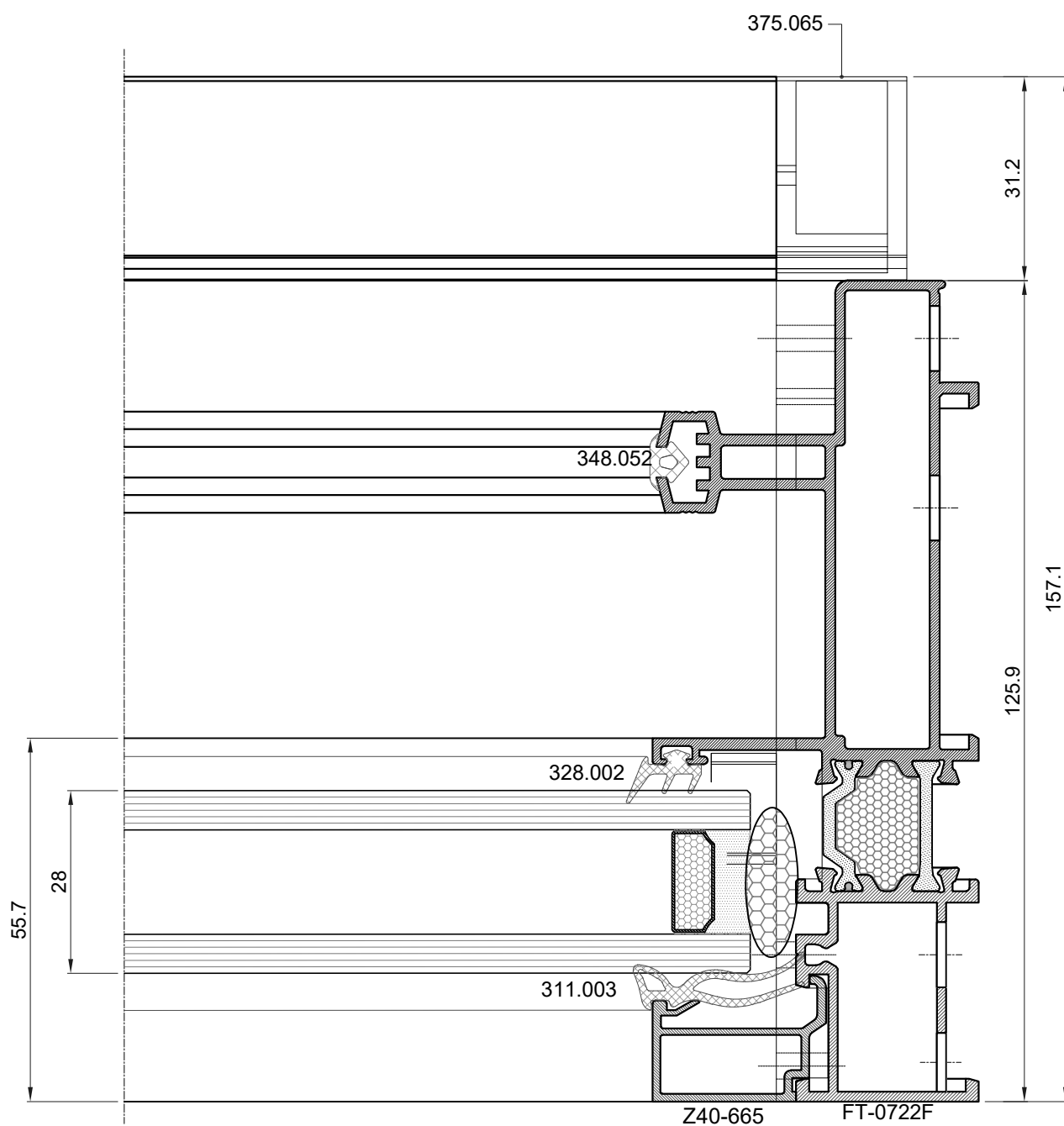
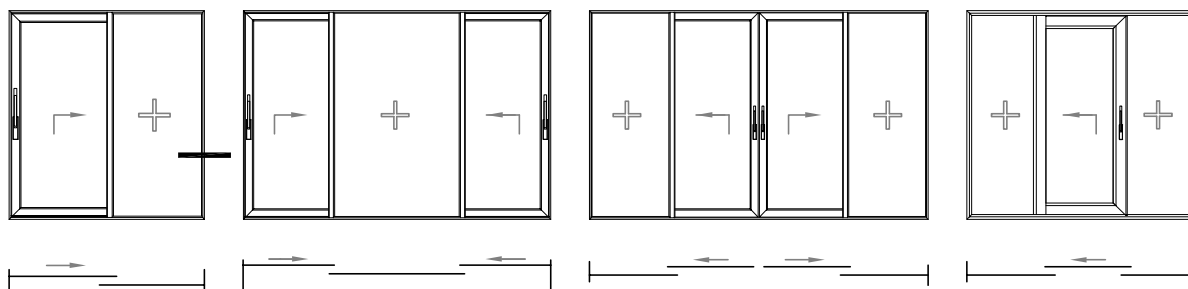

**Spojevi s drugim
sistemima i RAL ugradnja**
Connection with other
systems and RAL
installation

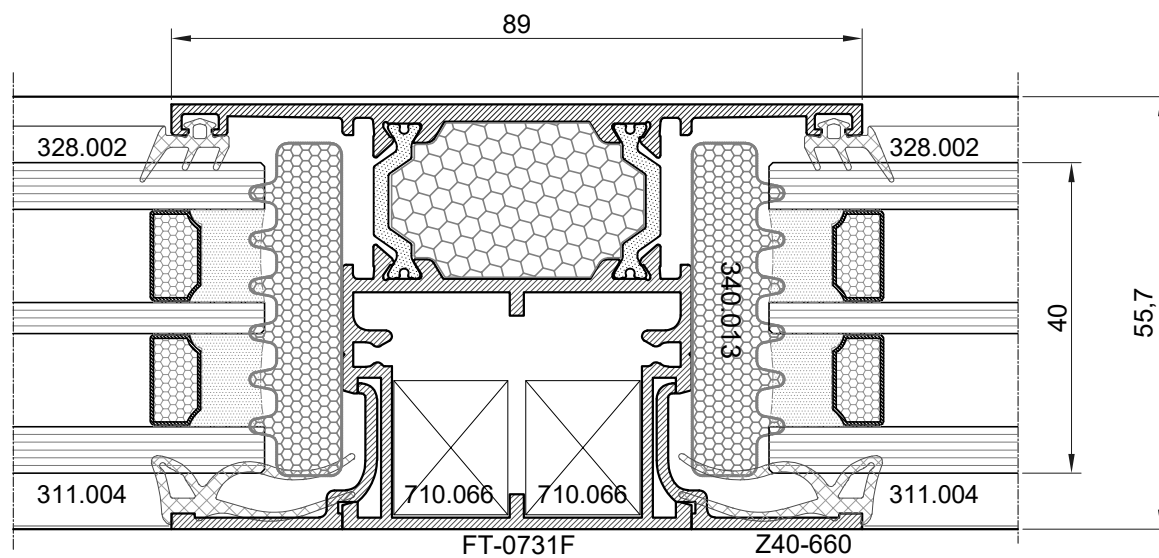
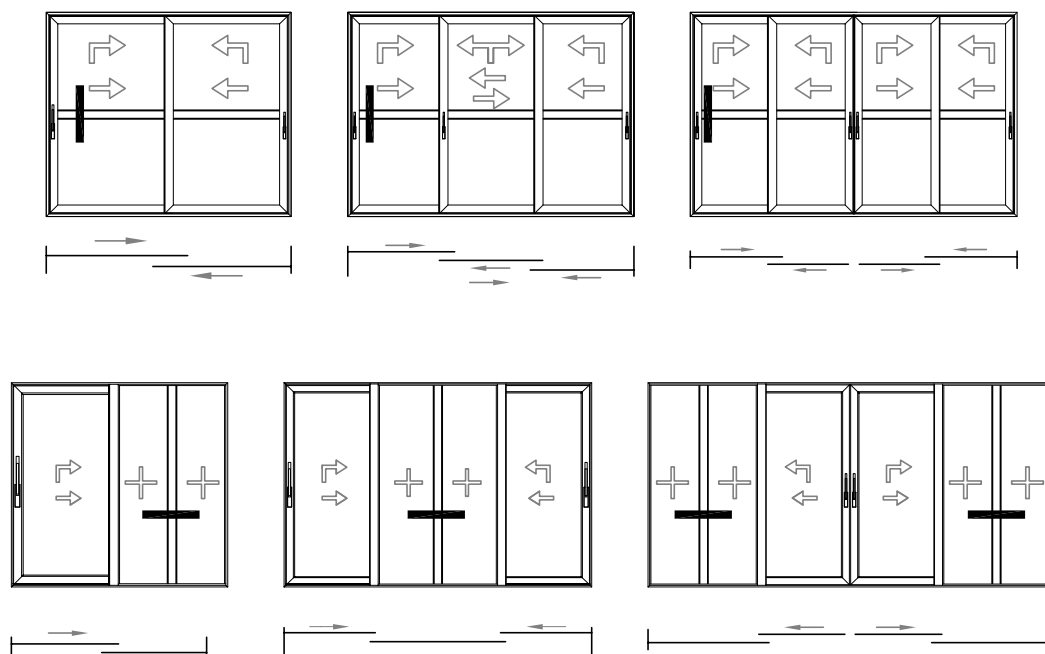

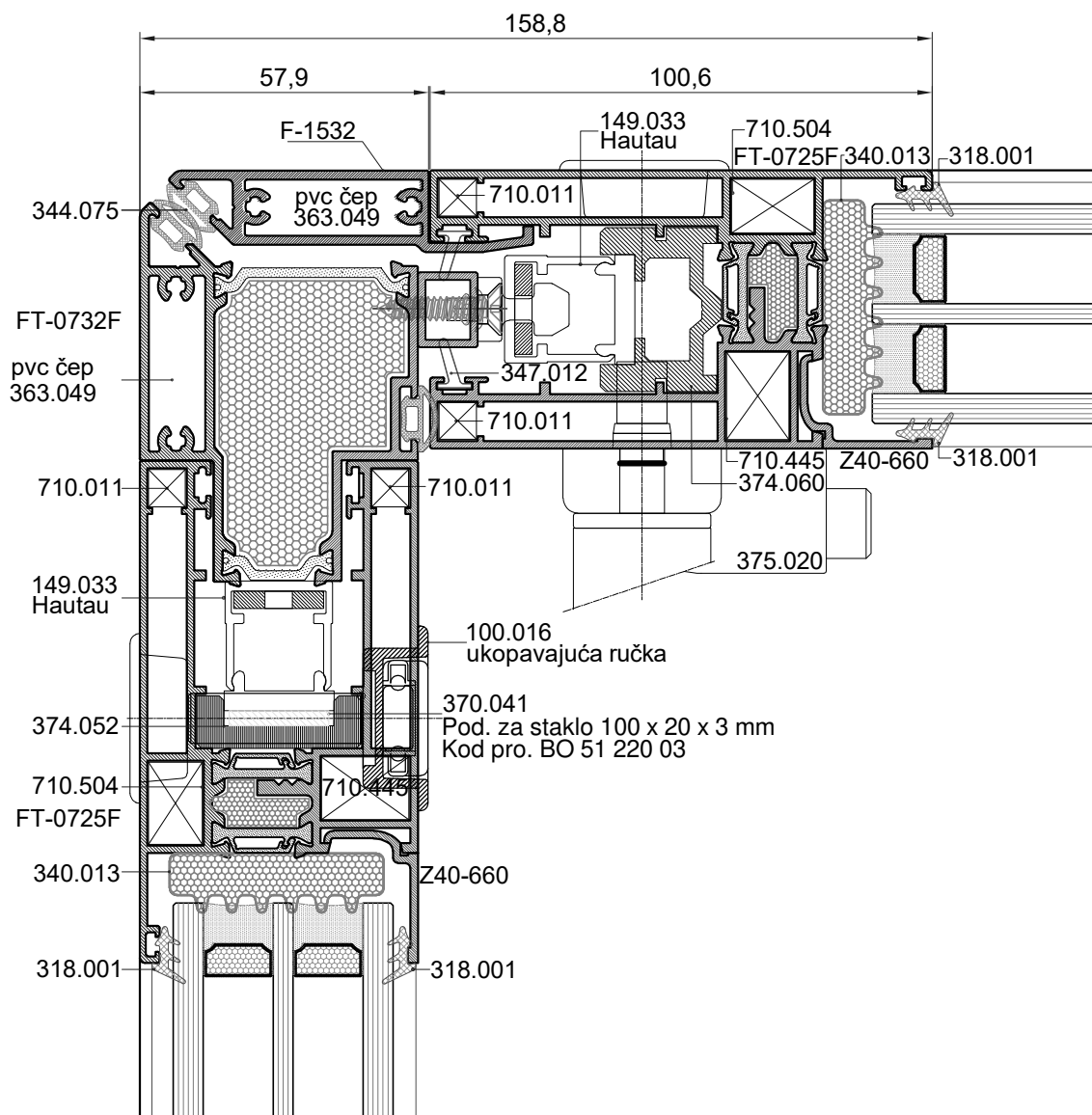
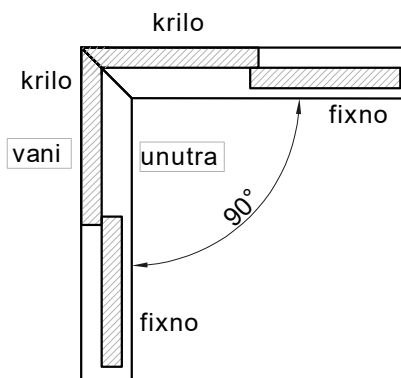
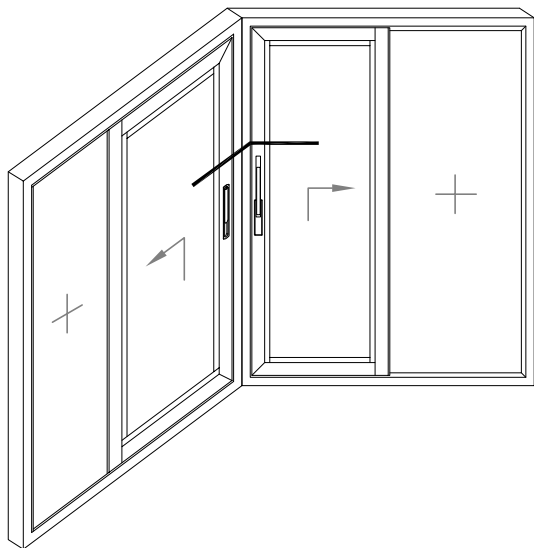

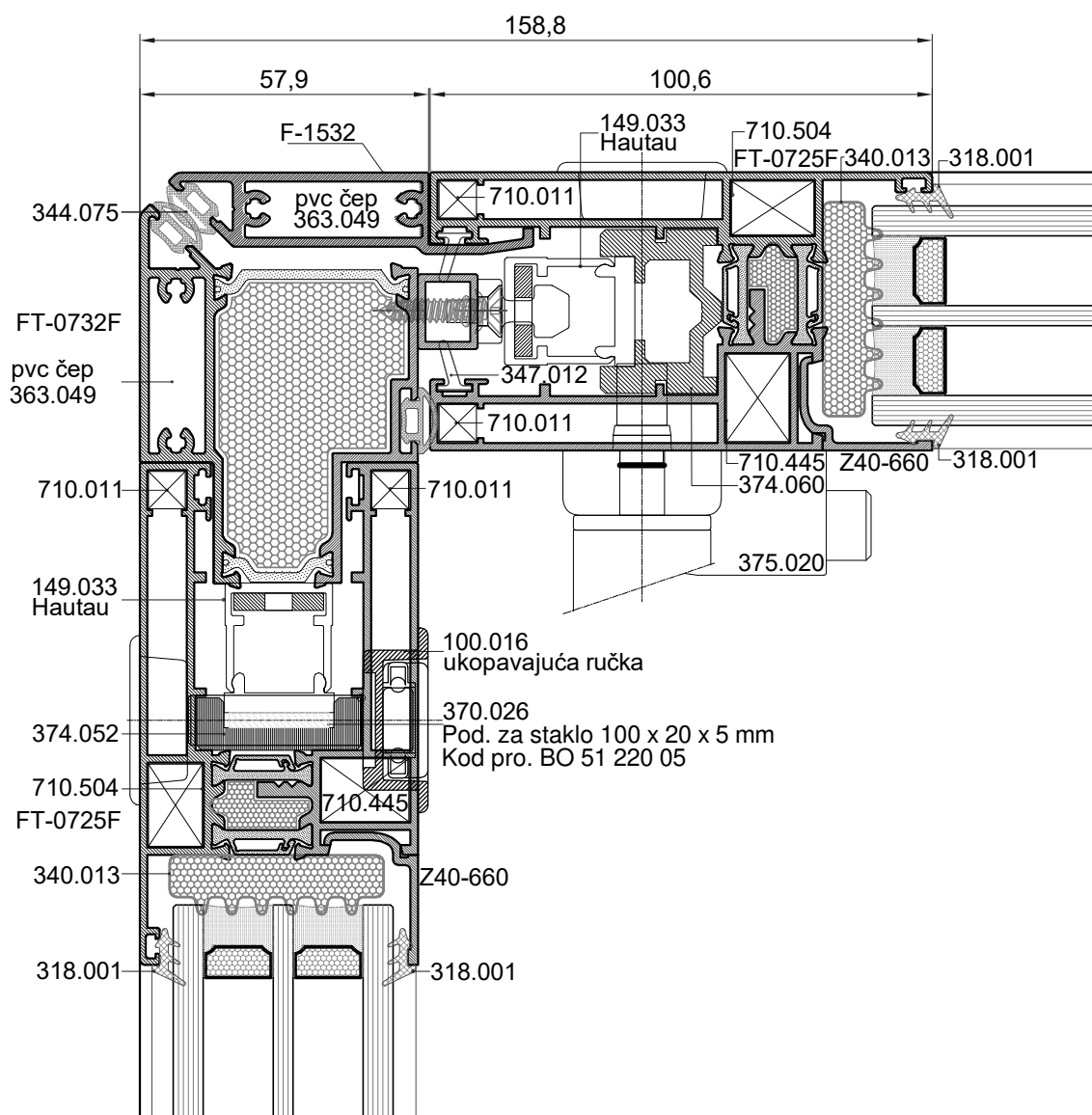
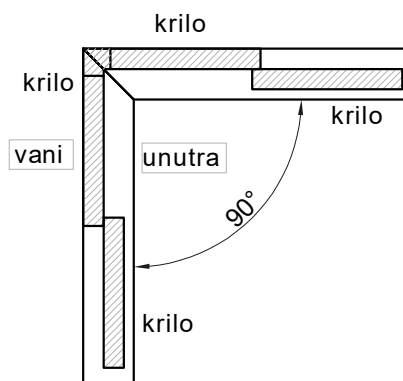
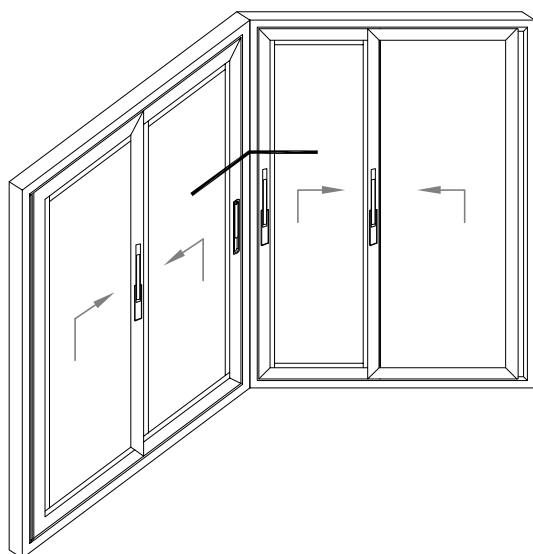

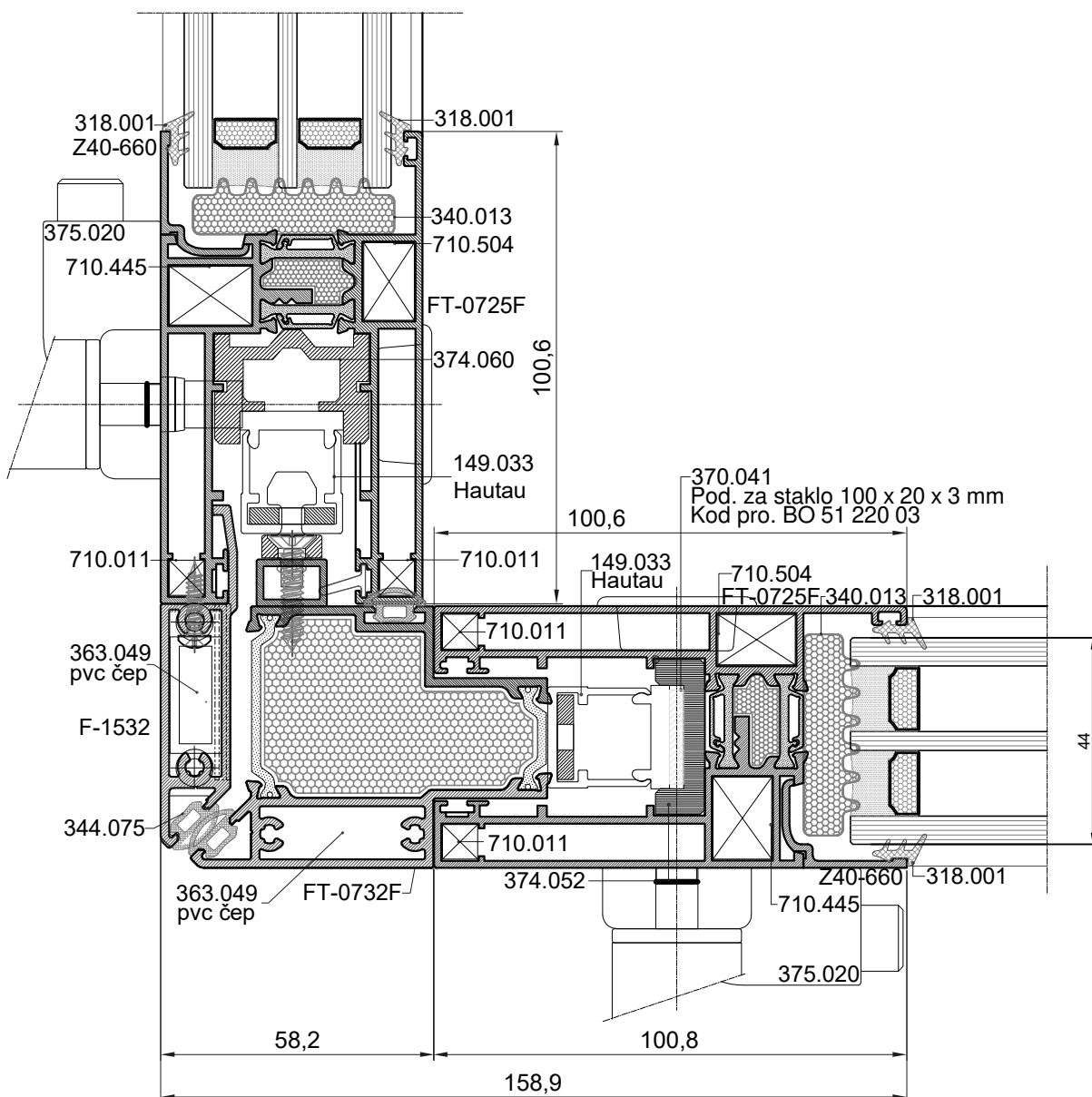
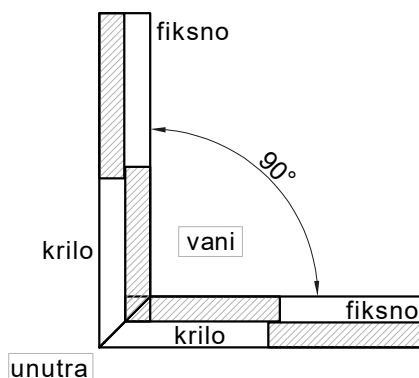
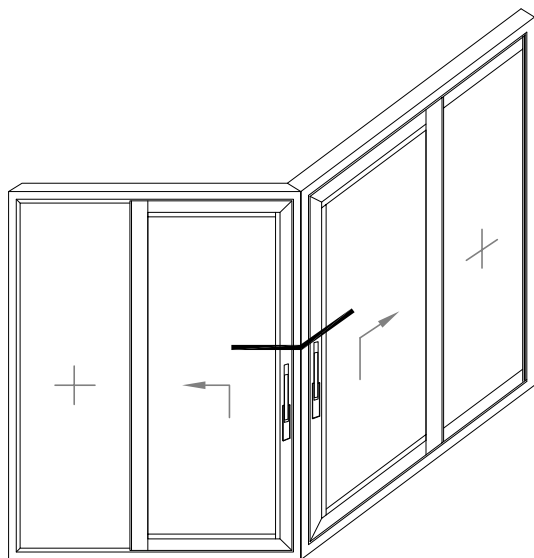

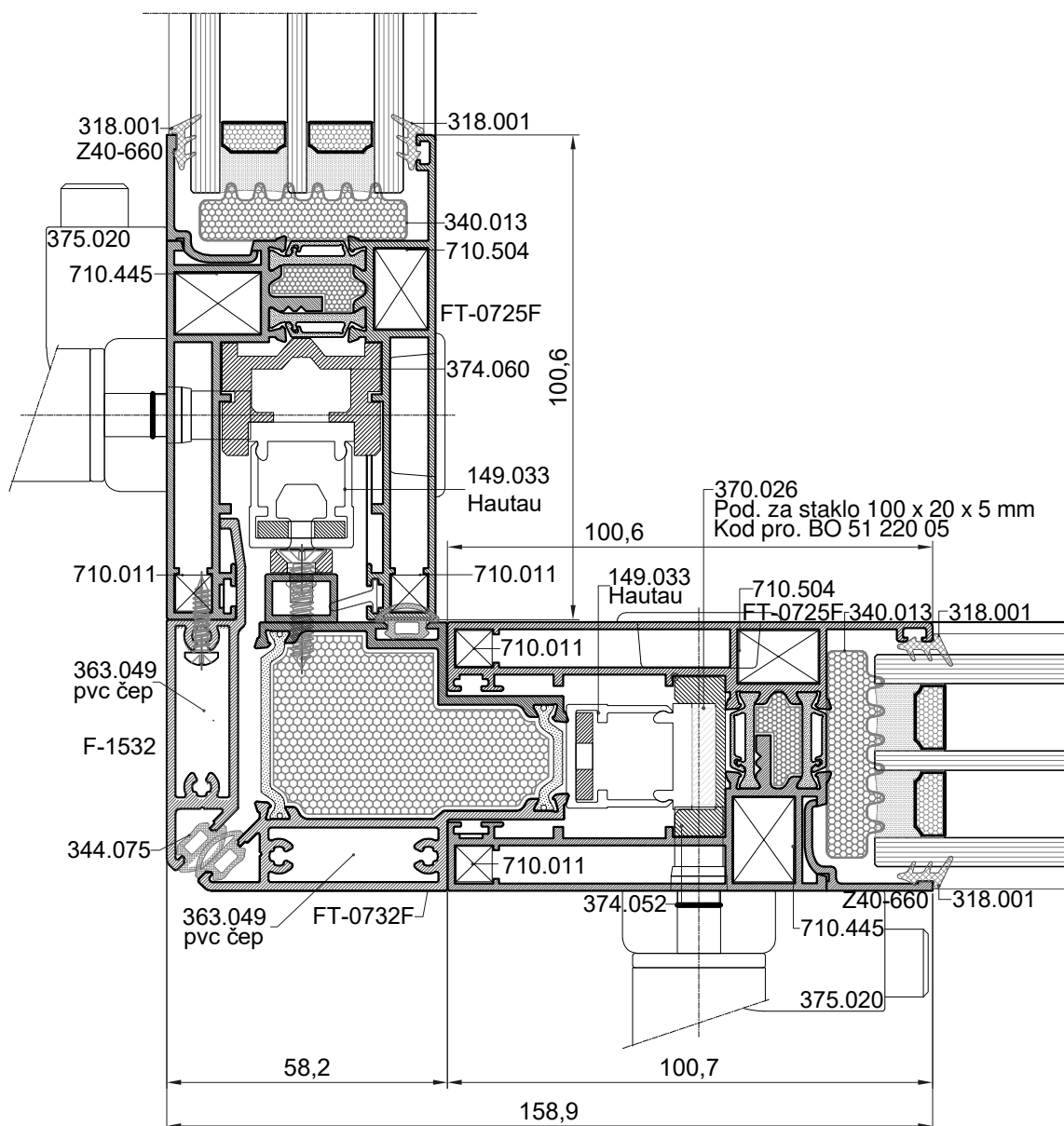
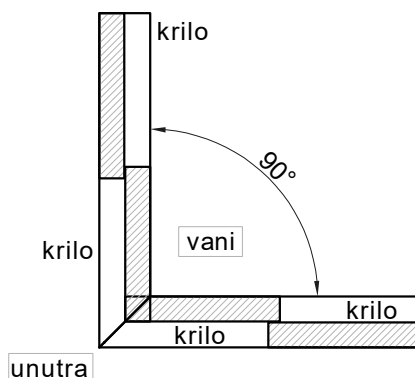
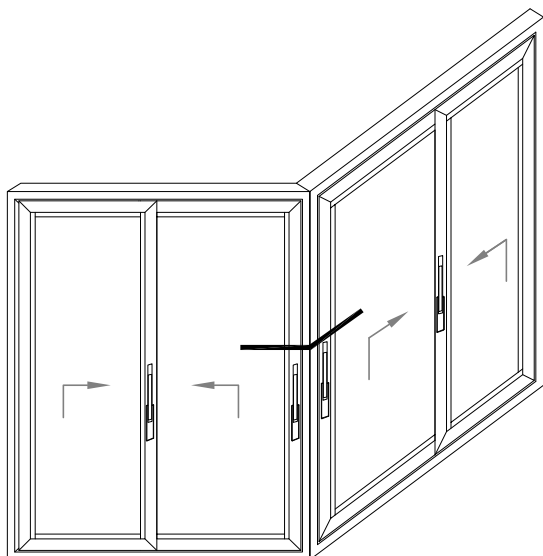

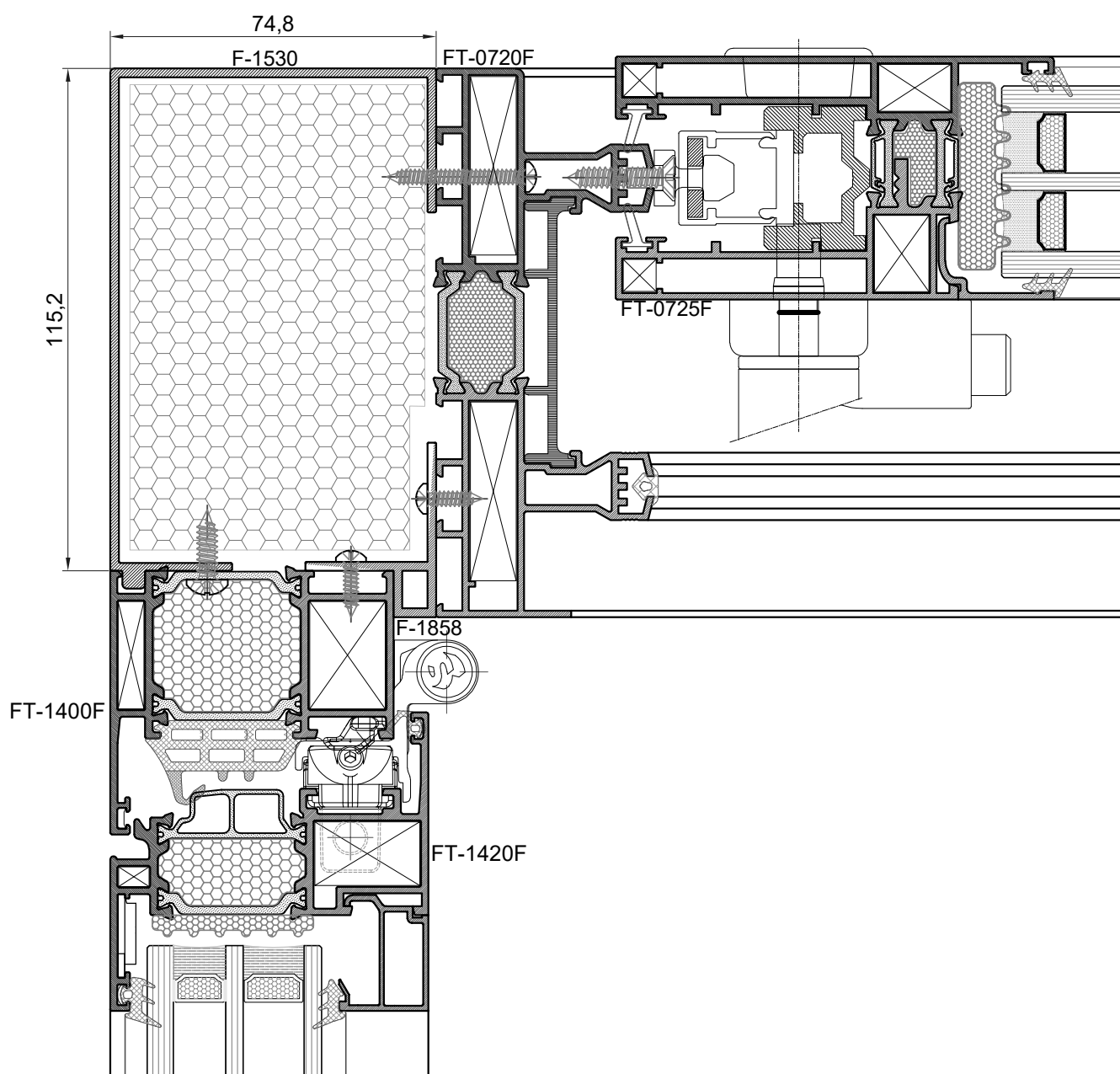
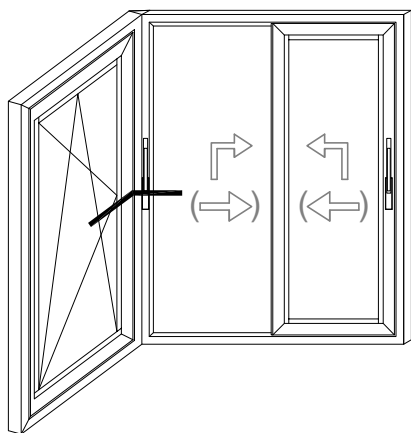

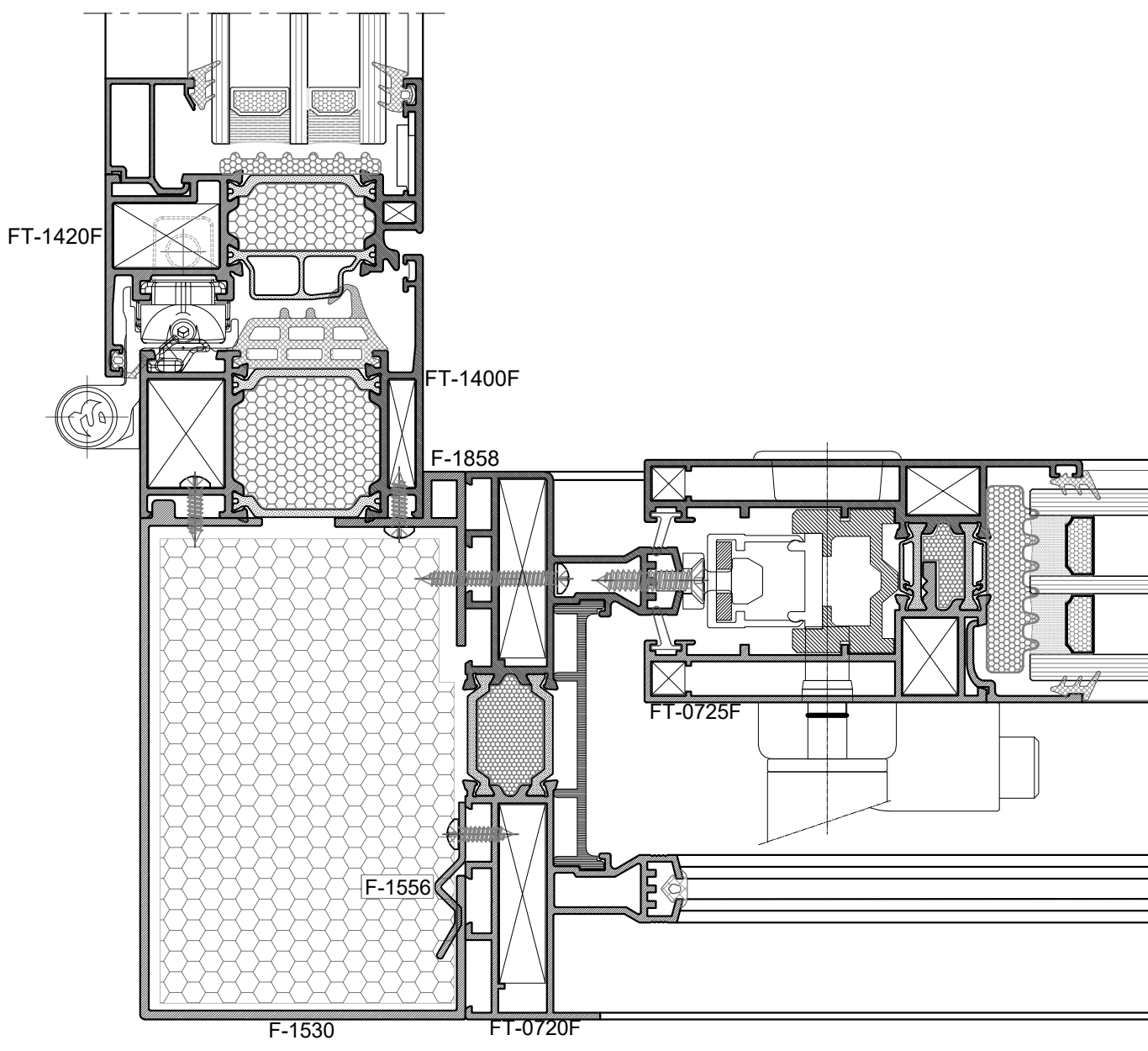
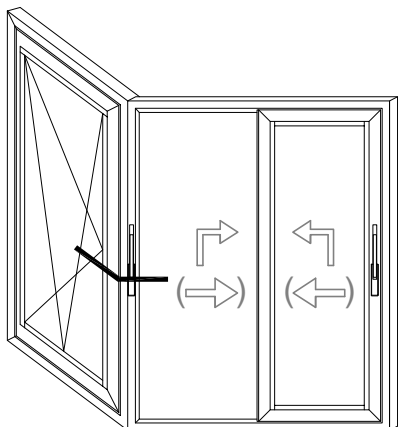

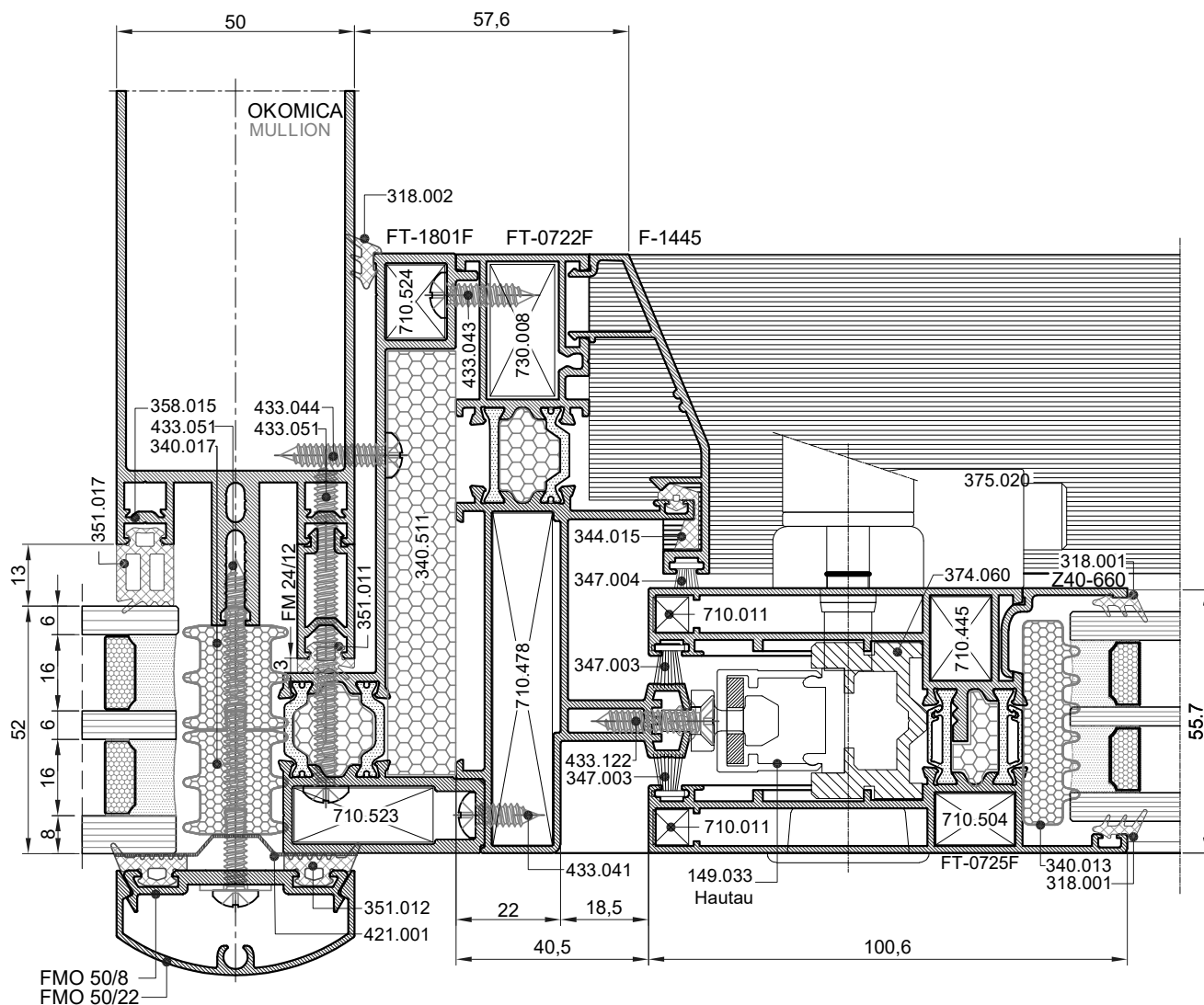
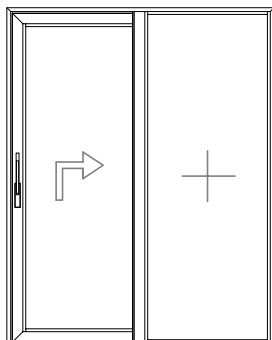

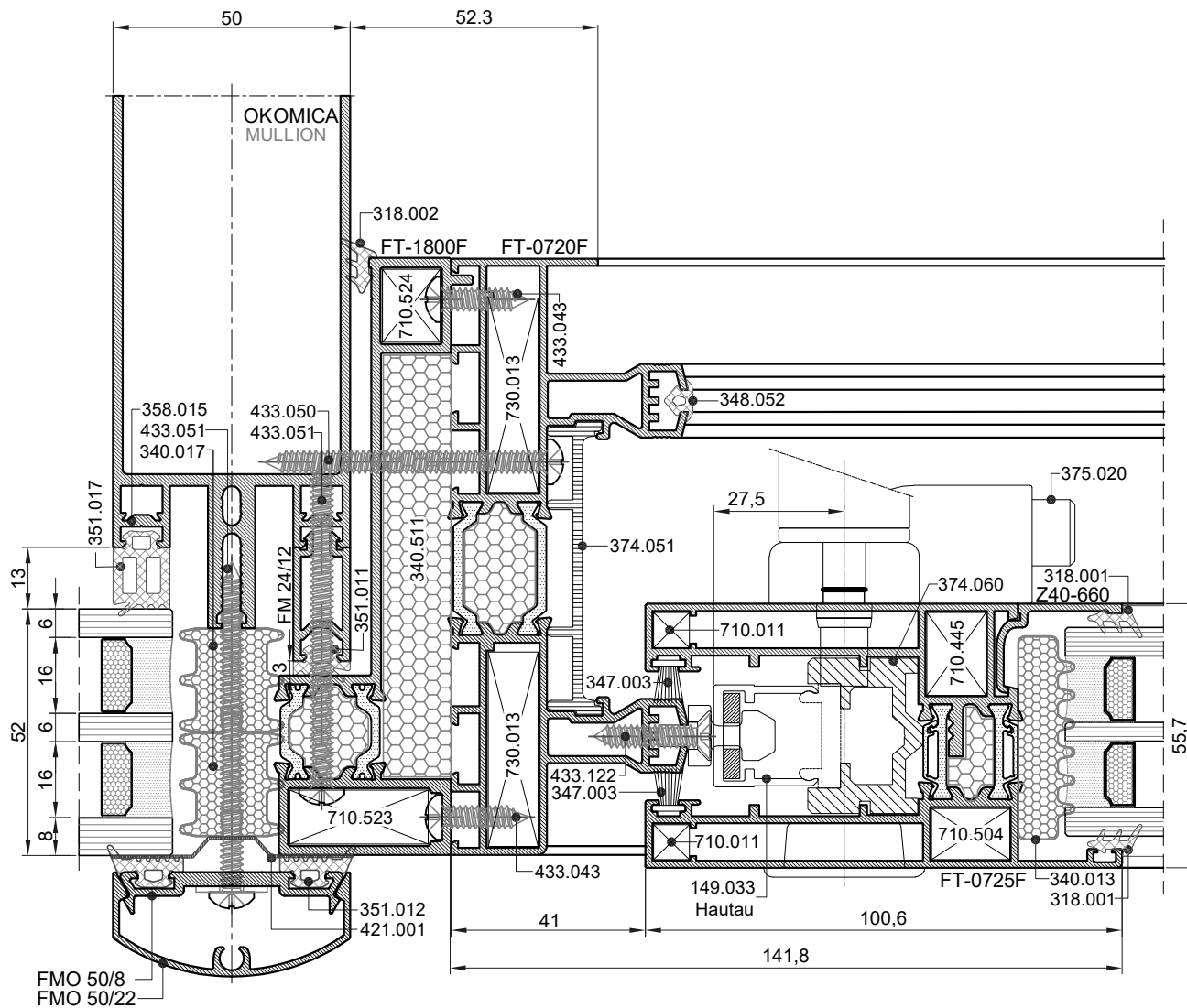
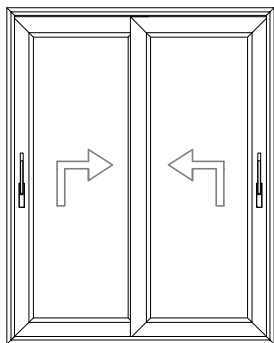

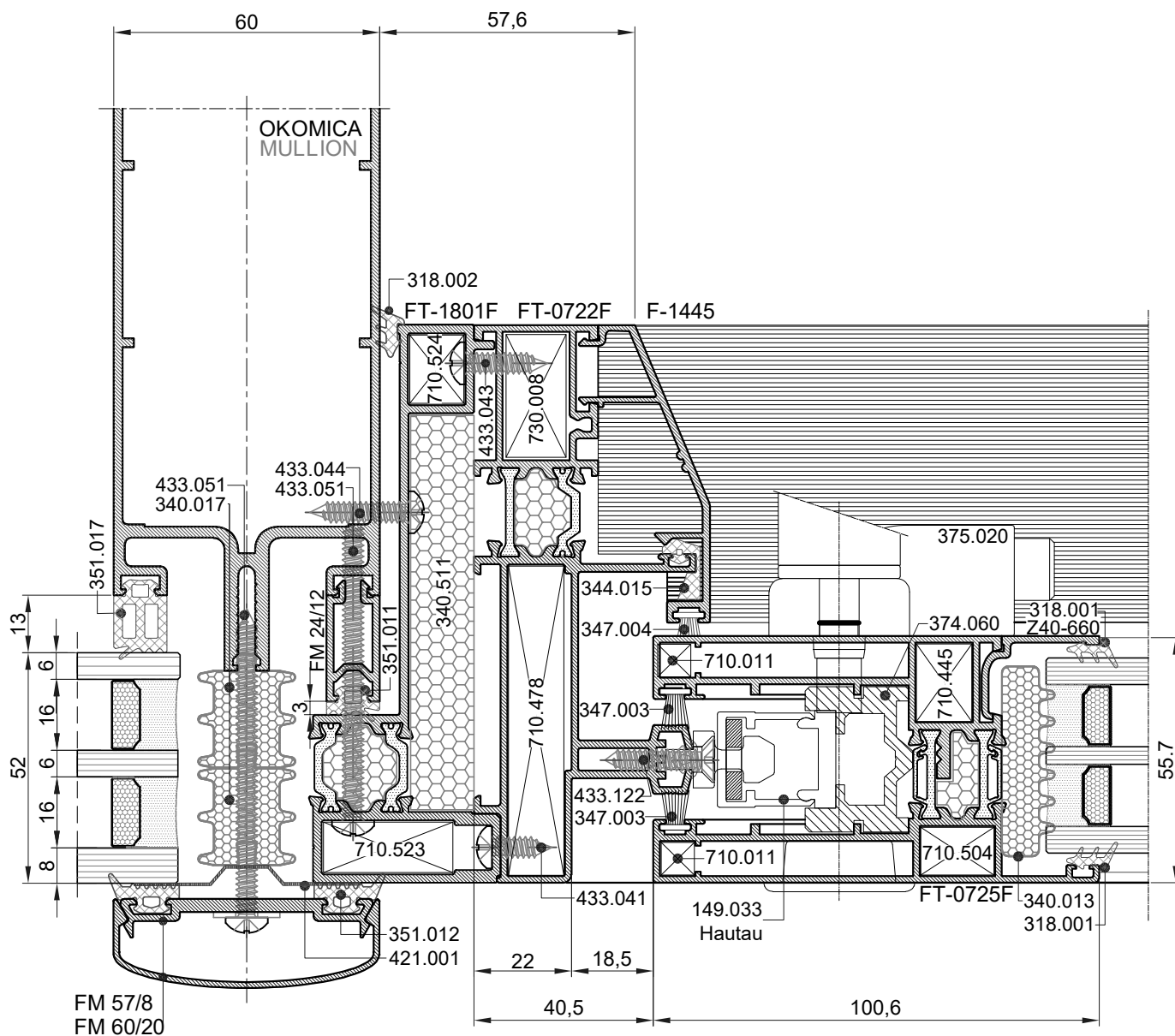
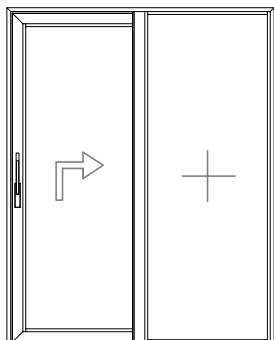

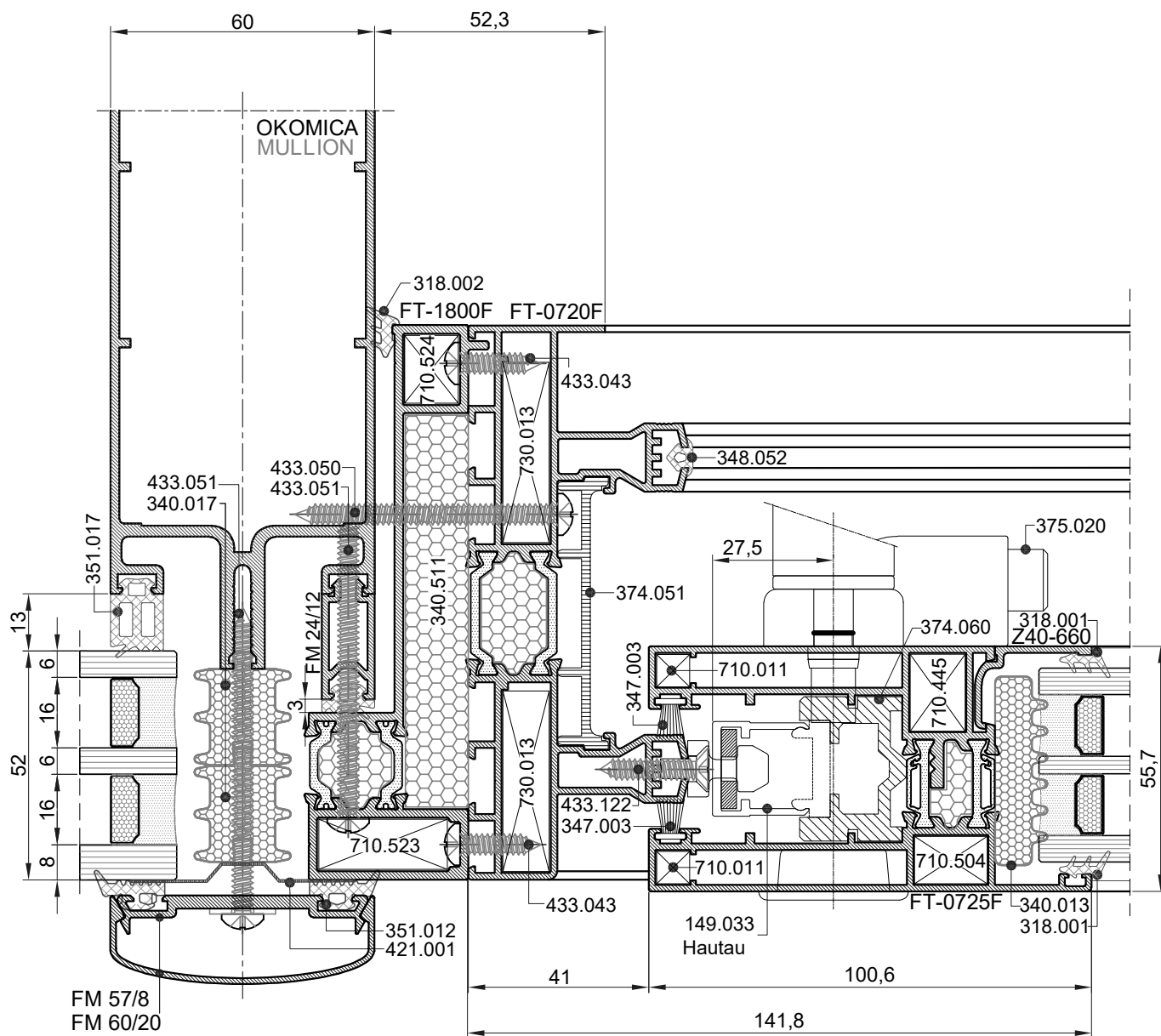
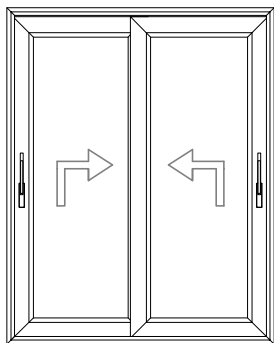

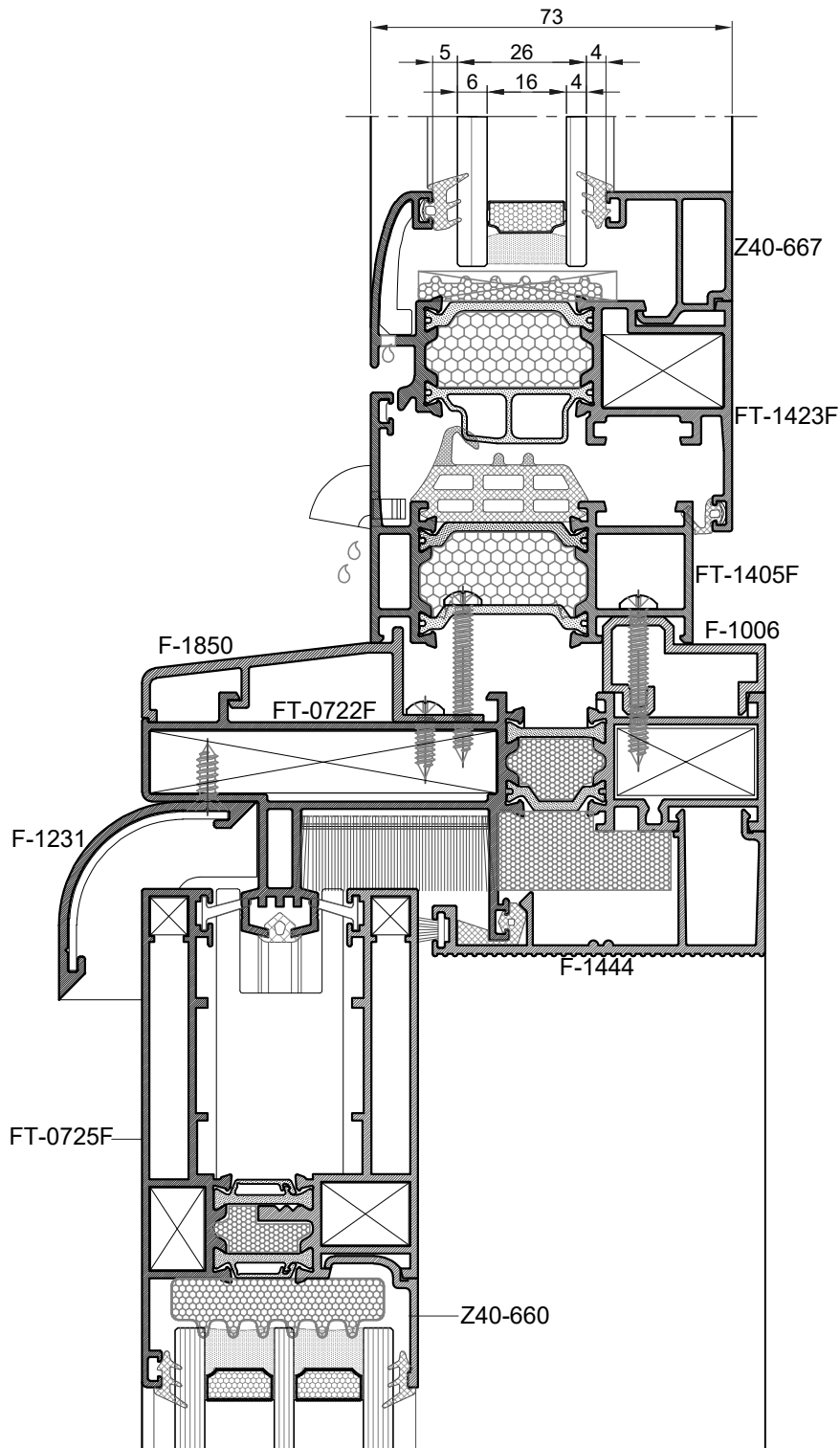
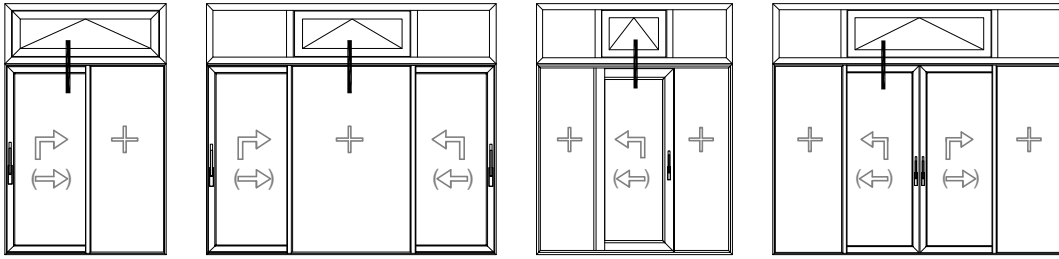

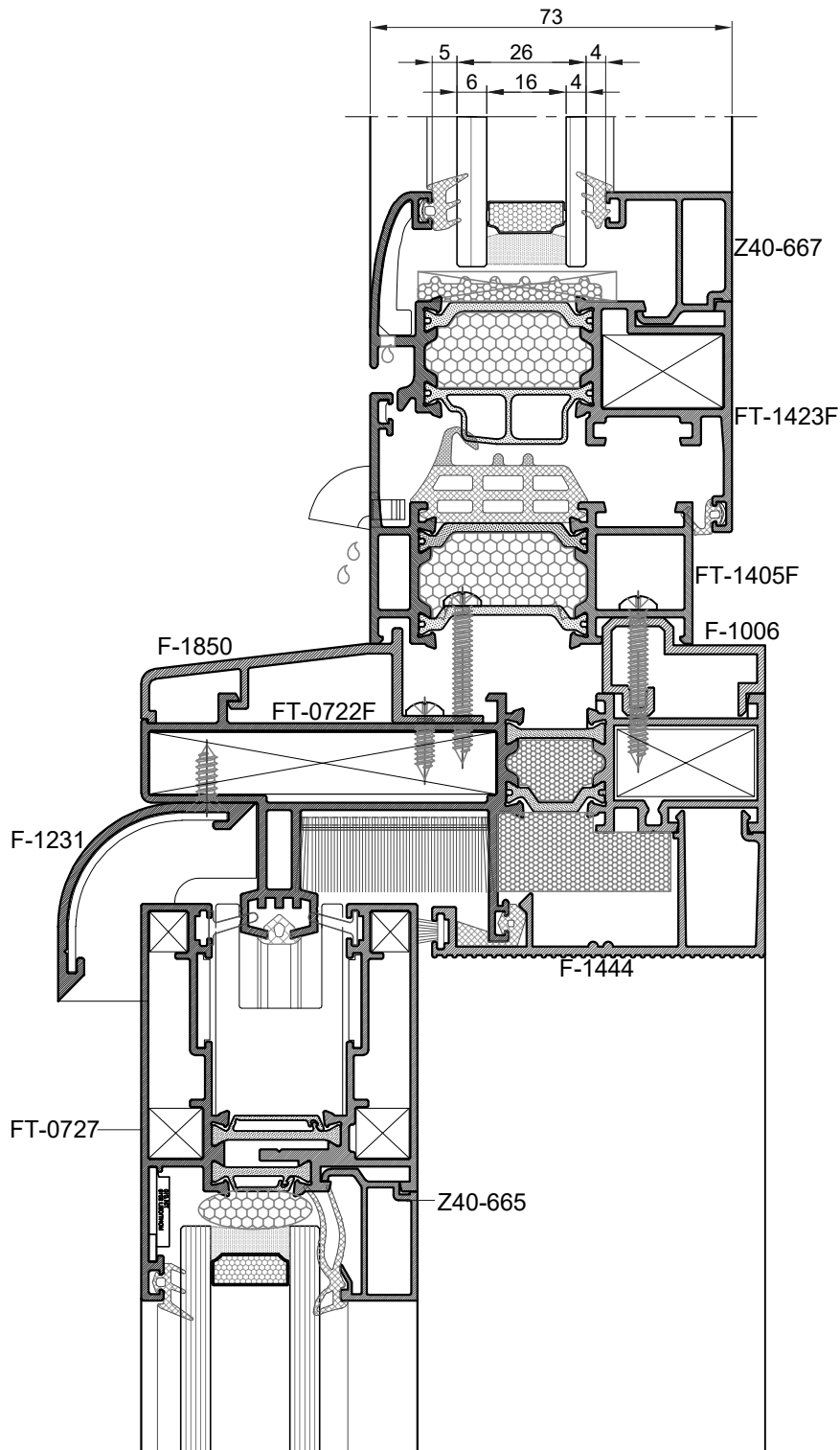
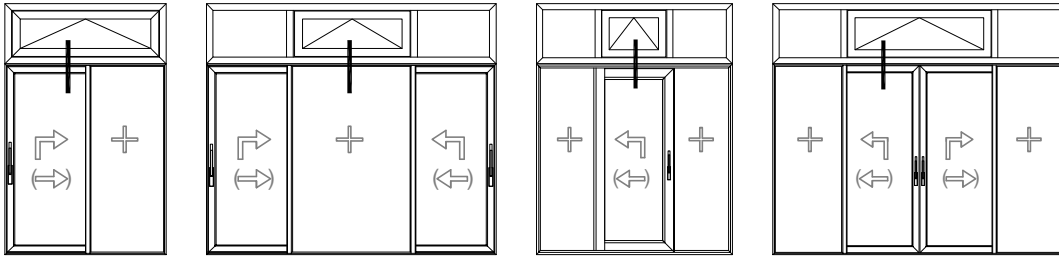

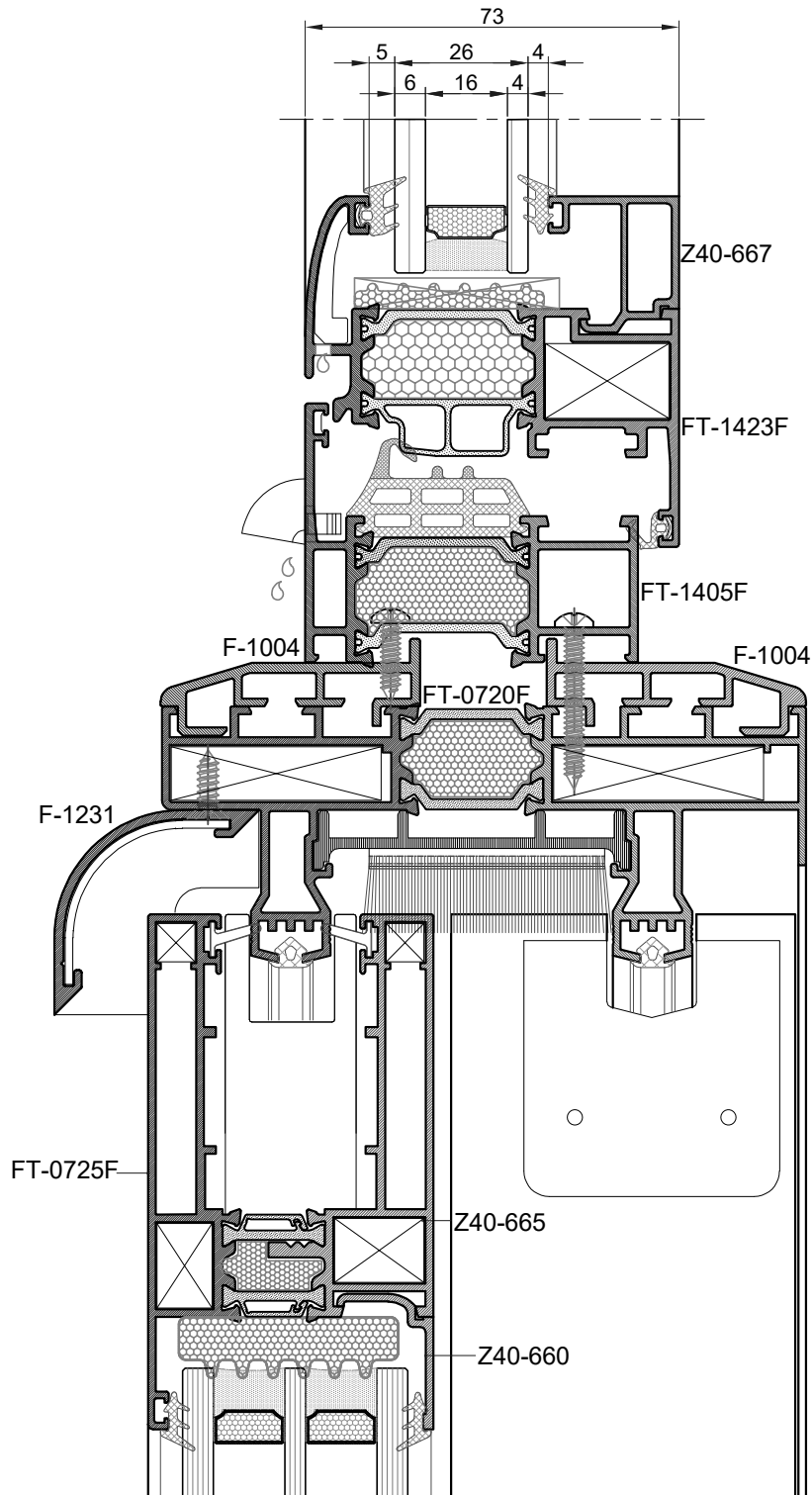
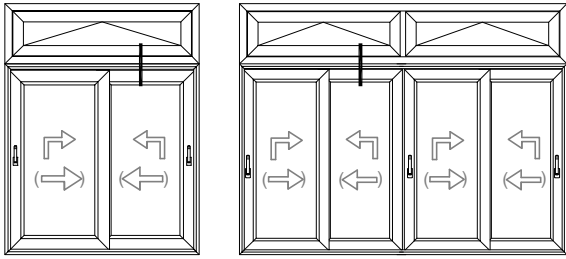

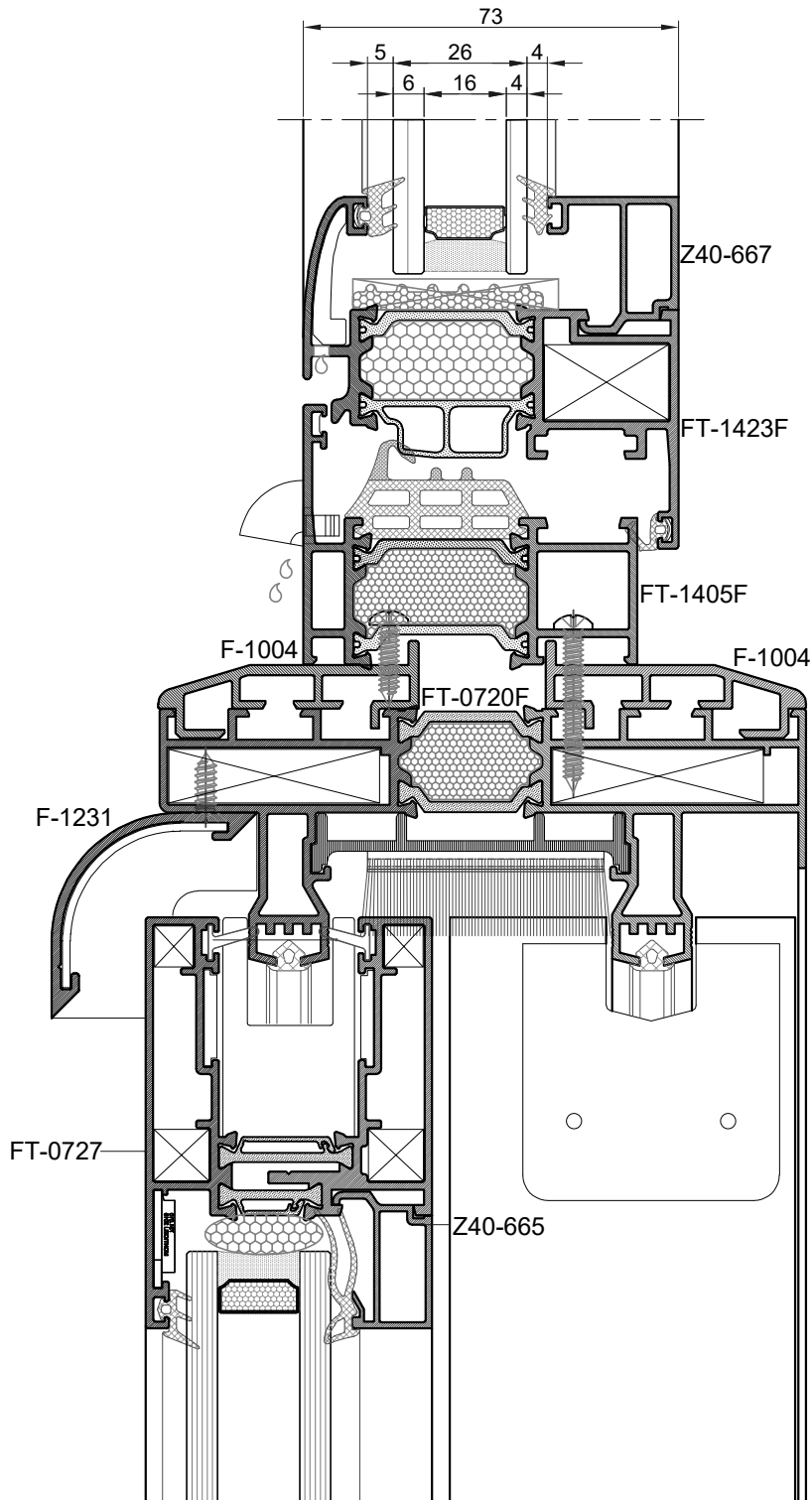
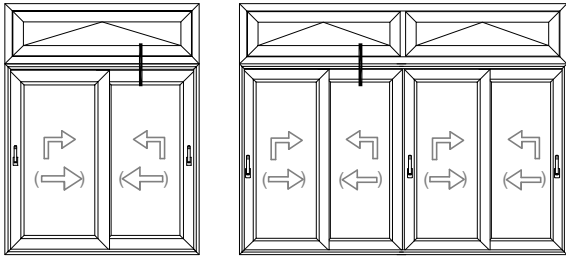

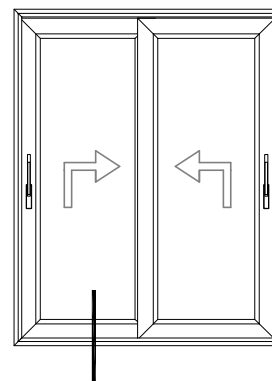

- unutarnji gotov pod (kamen,keramika)
- fleksibilno građevinsko ljepilo
- estrih
- termoizolacija
- paro- i vodonepropusna folija (parna brana)
- purenit-izolacijska ploča
- paropropusna i vodonepropusna folija (hidroizolacija)
- sakupljač kapljevina F-1481
- mreža 340.047
- F-1478 al profil maska sakupljača kapljevina
- cijev za odvod kapljevina (položena u estrih, izvodi kapljevine vani iz sakupljača kapljevina)
- estrih
- polimer-cementna hidroizolacija
- fleksibilno građevinsko ljepilo
- vanjska završna obrada
- inside finished floor(stone;ceramic)
- flexible construction adhesive
- screed
- thermal insulation
- vapor and water impermeable foil (vapor barrier)
- purenit thermal insulation
- vapor permeable and water impermeable (hydro insulation)
- liquid collector F-1481
- net 340.047
- F-1478 al profile mask of liquid collector
- tube for drainage liquids (sited in the screed, drainage liquids out from collector)
- screed
- polymer-cement weather protection
- flexible construction adhesive
- outside finishing

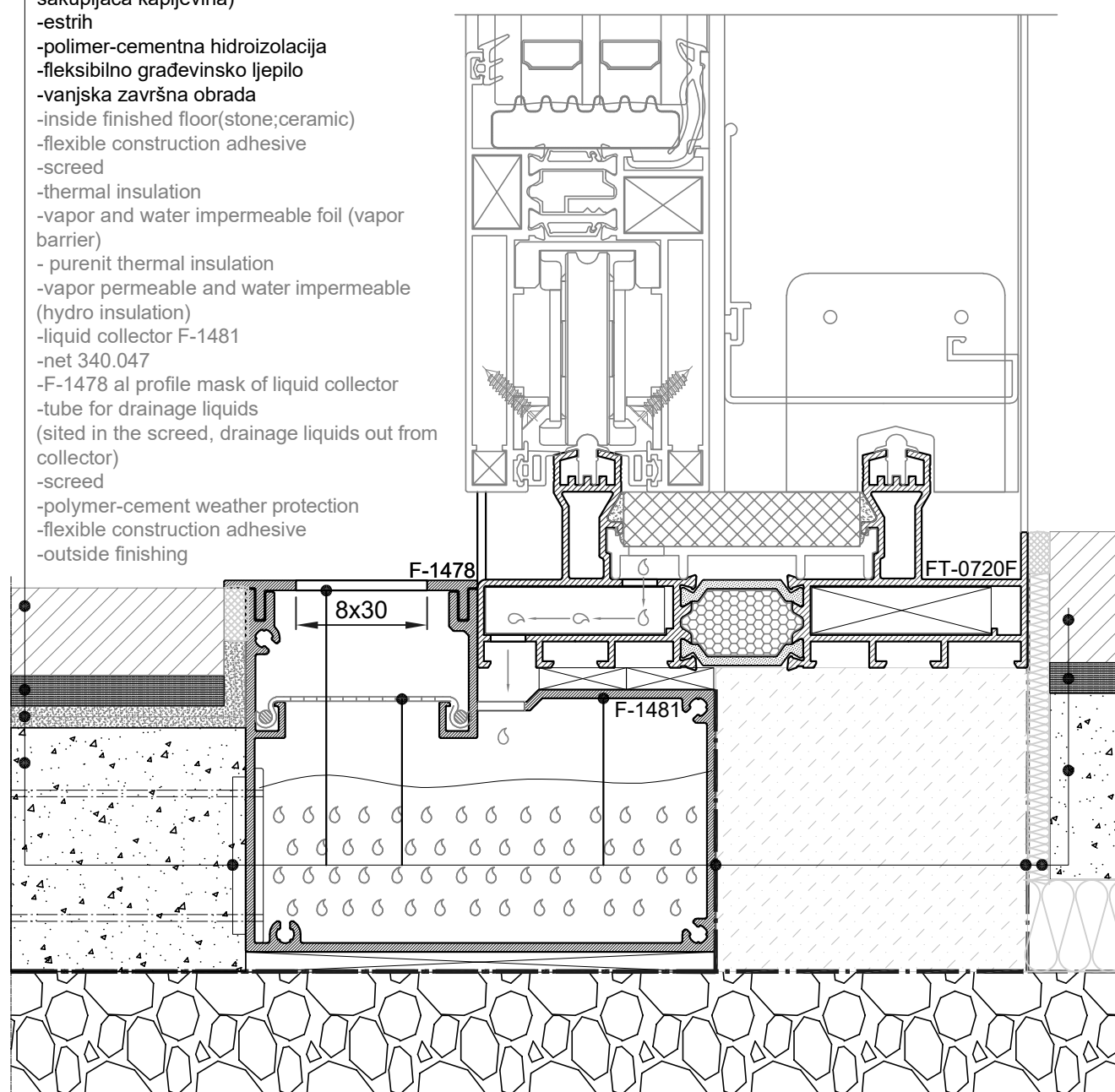

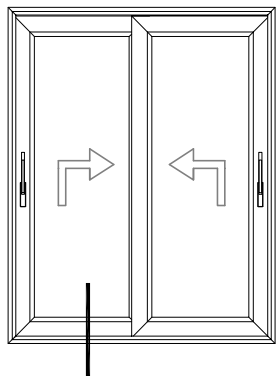

NAPOMENA: Ovakav način montaže primjenjiv je za pozicije koje nisu izložene direktnom udaru vjetra i vode
This mounting method is applicable for positions that are not exposed direct impact of wind and water

- Završna lajsna poda
- Unutarnji gotov pod
- Estrih
- Parna brana(paronepropusna folija) za sprječavanje prolaska vodene pare iz prostorije u termoizolaciju (npr.Würth 0875 071 00)
- Termoizolacija(Purenit)
- Hidroizolacija(paropropusna i vodonepropusna folija) za zaštitu termoizolacije od kapljevina s vana (npr.Würth 0875 350 201)
- Pvc profil 374.037+pvc cijev 65x15 (374.069)
- Trajno elastični kit
- Aluminijski ram-FT-0720F
- Vanjski gotov pod
- Estrih
- Floor skirting profile
- Internal finished floor
- Floor screed
- Vapor barrier (vapor-permeable film) to prevent the passage of water vapor from the room into the thermal insulation (e.g. Würth 0875 071 00)
- Thermo insulation (Purenite)
- Waterproofing (vapor-permeable and waterproof foil)for protecting the thermal insulation from liquids from the outside (e.g. Würth 0875 350 201)
- Pvc profile 374.037+pvc tube 65x15 (374.069)
- Permanently elastic mass
- Aluminium frame-FT-0720F
- External finished floor
- Floor screed

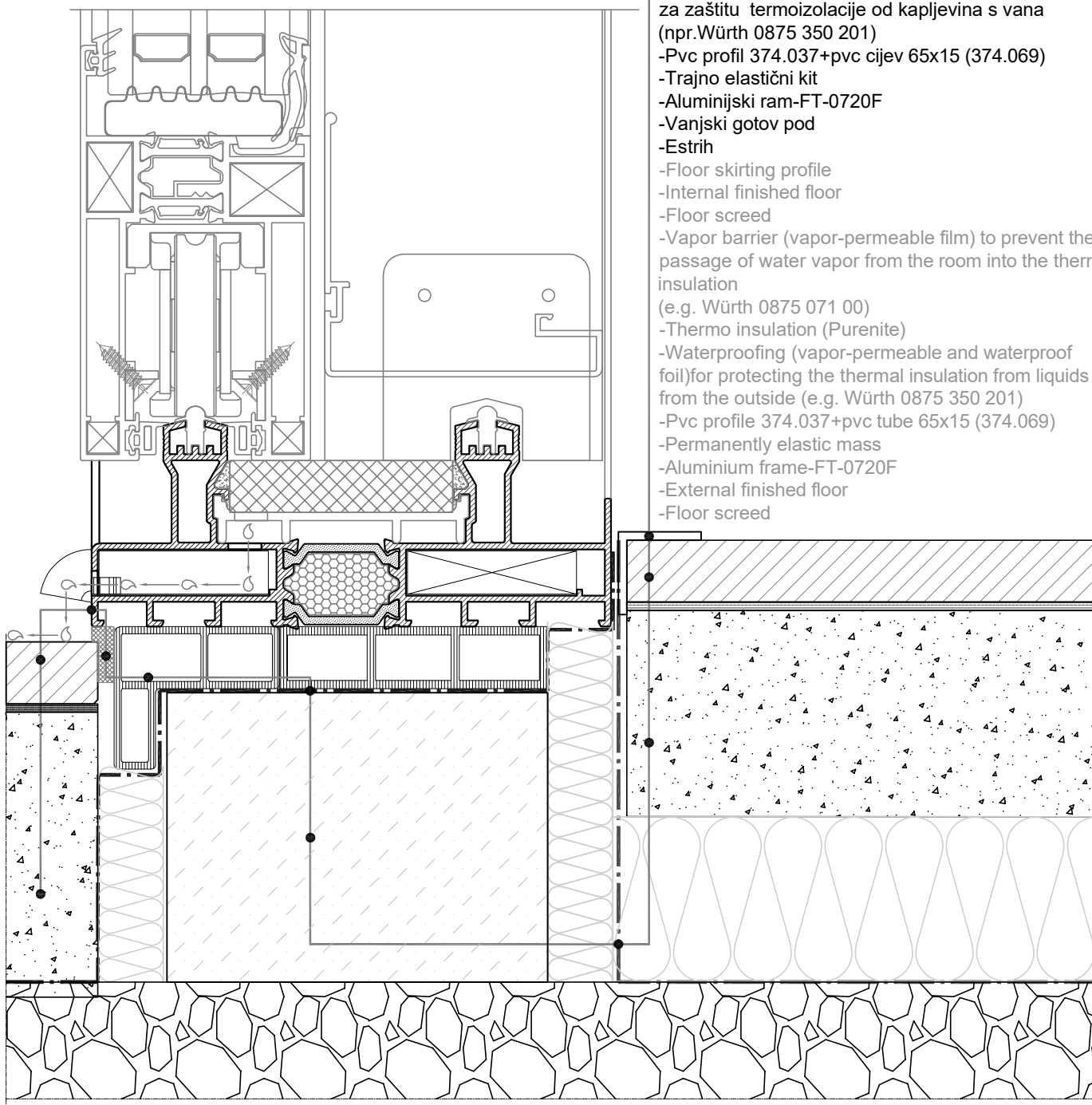

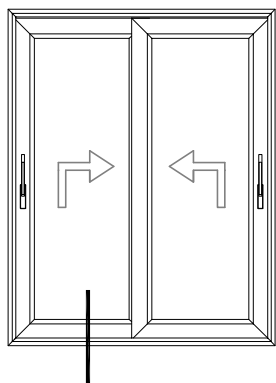

- Unutarnja završna obrada
- Fleksibilno građevinsko ljepilo
- Estrih
- Termoizolacija
- Paro i vodonepropusna folija (parna brana)
- Purenit - izolacijska ploča
- Paropropusna i vodonepropusna folija (hidroizolacija)
- Čepasta membrana (drenaža)
- Estrih
- Polimer-cementna hidroizolacija
- Fleksibilno građevinsko ljepilo
- Vanjski završni izgled (keramika / kamen)
- Internal finishing
- Flexible construction adhesive
- Screed
- Thermal insulation
- Vapour (Air tight) barrier (vapour and water proof tape), (eg. Iso Chemie: Iso-Connect Inside CX)
- Purenit (insulation board)+++
- Weather protection (vapourpermable and water proof tape) (eg. Iso Chemie: Iso-Connect Outside CX)+++
- Gutabetta membrane (drainage)+++
- Screed+++
- Polymer-cement weather protection+++
- Flexible construction adhesive+++
- Outside finishing (stone/ceramic)+++

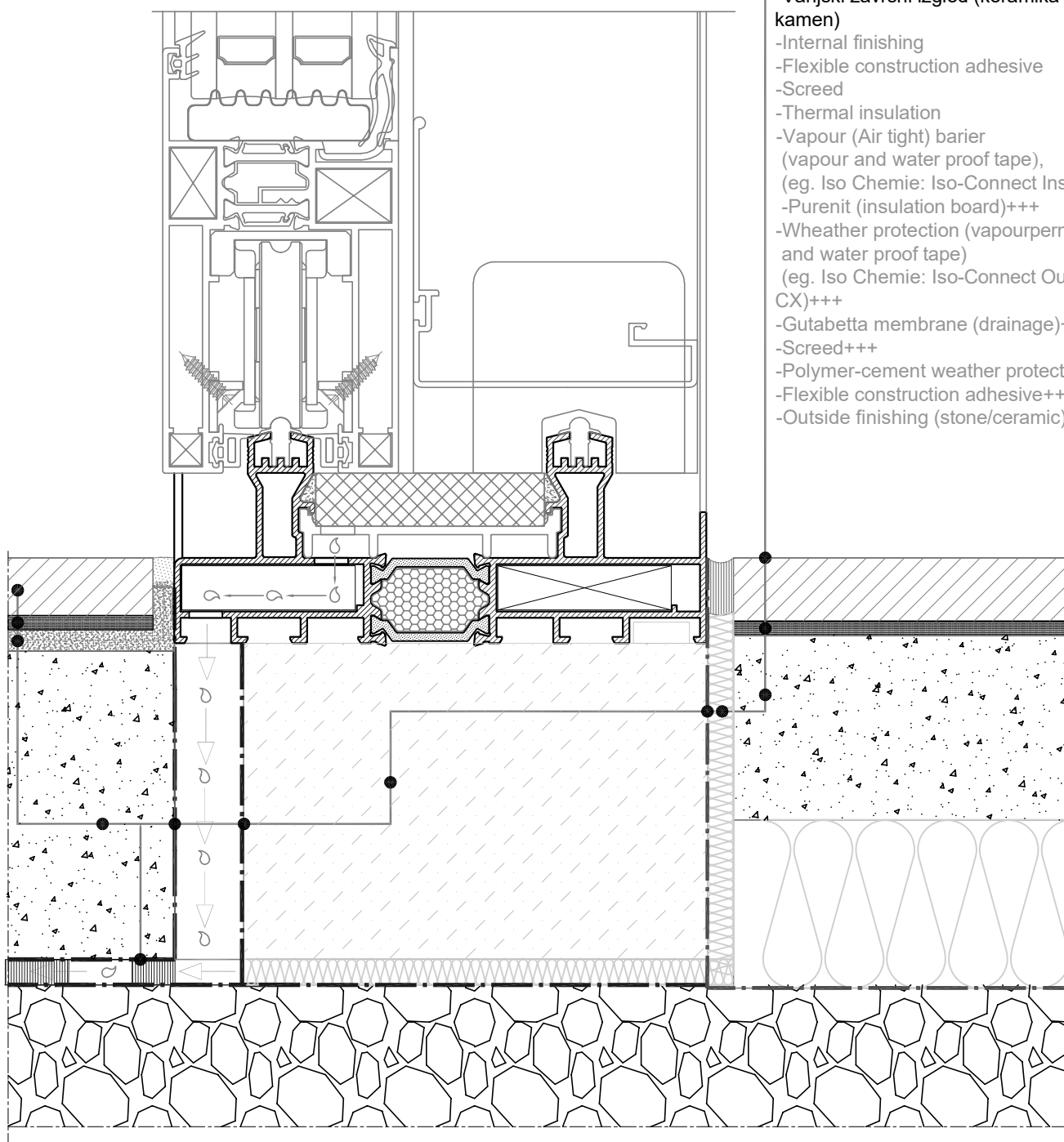

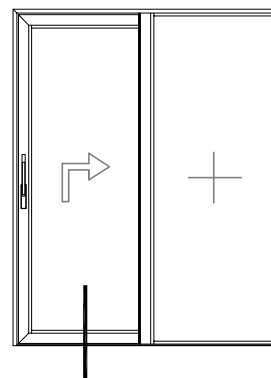

- unutarnji gotov pod (kamen,keramika)
- fleksibilno građevinsko ljepilo
- estrih
- termoizolacija
- paro- i vodonepropusna folija (parna brana)
- purenit-izolacijska ploča
- paropropusna i vodonepropusna folija (hidroizolacija)
- sakupljač kapljevina F-1481
- mreža 340.047
- F-1478 al profil maska sakupljača kapljevina
- cijev za odvod kapljevina (položena u estrih, izvodi kapljevine vani iz sakupljača kapljevina)
- estrih
- polimer-cementna hidroizolacija
- fleksibilno građevinsko ljepilo
- vanjska završna obrada
- inside finished floor(stone;ceramic)
- flexible construction adhesive
- screed
- thermal insulation
- vapor and water impermeable foil (vapor barrier)
- purenit thermal insulation
- vapor permeable and water impermeable (hydro insulation)
- liquid collector F-1481
- net 340.047
- F-1478 al profile mask of liquid collector
- tube for drainage liquids (sited in the screed, drainage liquids out from collector)
- screed
- polymer-cement weather protection
- flexible construction adhesive
- outside finishing

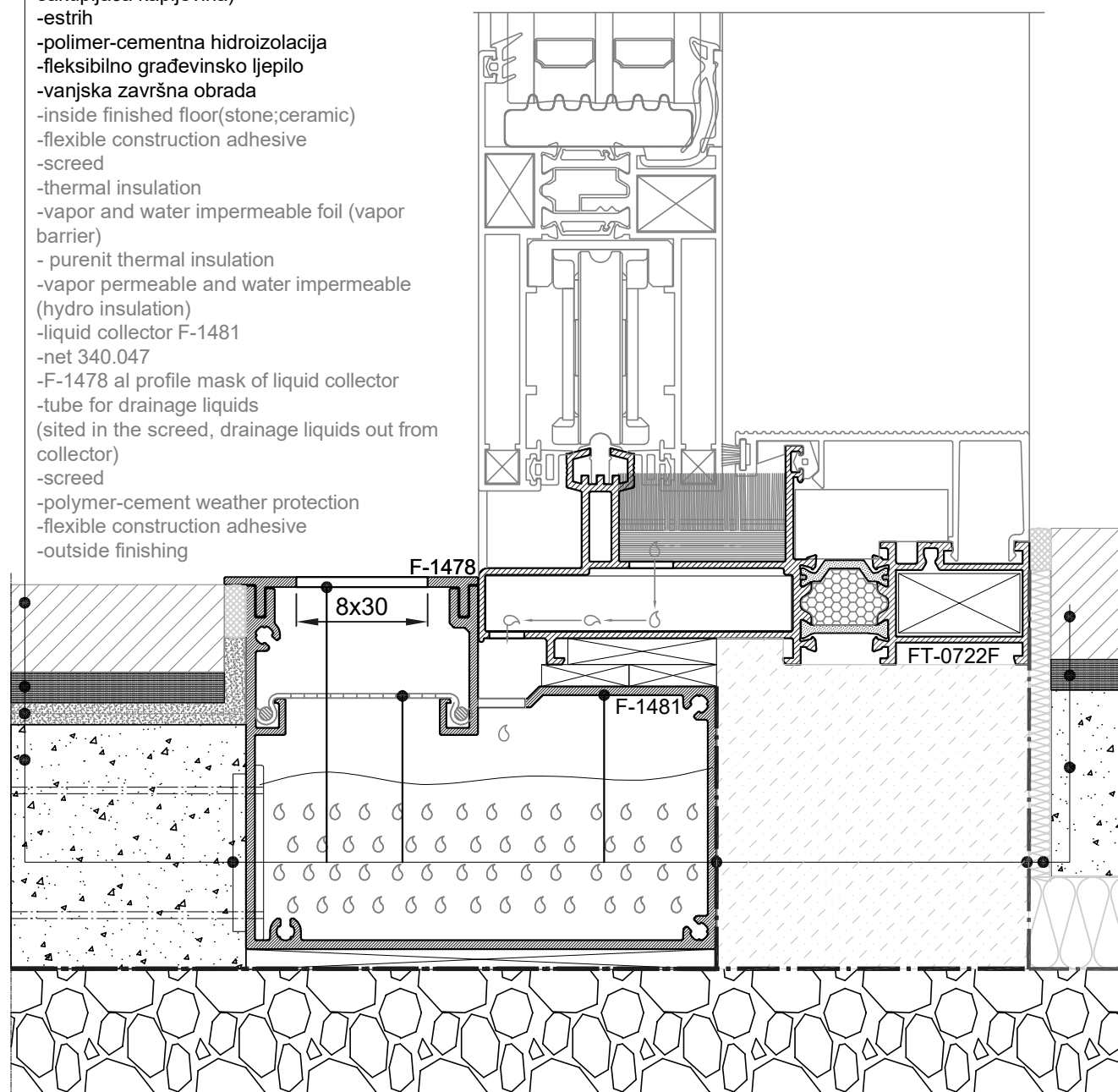

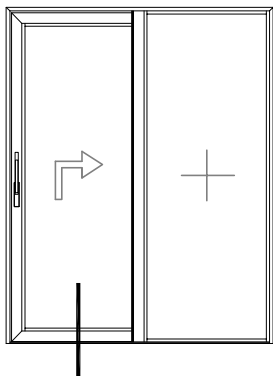

NAPOMENA: Ovakav način montaže primjenjiv je za pozicije koje nisu izložene direktnom udaru vjetrova i vode
This mounting method is applicable for positions that are not exposed direct impact of wind and water

- Završna lajsna poda
- Unutarnji gotov pod
- Estrih
- Parna brana(paronepropusna folija) za sprječavanje prolaska vodene pare iz prostorije u termoizolaciju (npr. Würth 0875 071 00)
- Termoizolacija(purenit)
- Hidroizolacija(paropropusna i vodonepropusna folija) za zaštitu termoizolacije (npr. Würth 0875 350 201)
- Pvc profil 374.037+pvc cijev 50x15 (374.070)
- Trajnoelastični kit
- Aluminijski ram-FT-0722F
- Vanjski gotov pod
- Estrih
- Floor skirting profile
- Internal finished floor
- Floor screed
- Vapor barrier (vapor-permeable film) - to prevent the passage of water vapor from the room into the thermal insulation(e.g. Würth 0875 071 00)
- Thermo isolation(Purenite)
- Waterproofing (vapor-permeable and waterproof foil) for protecting the thermal insulation from liquids from the outside(e.g. Würth 0875 350 201) 6
- Pvc profile 374.037+pvc tube 50x15 (374.070)
- Permanently elastic mass
- Aluminium frame-FT-0720F
- External finished floor
- Floor screed

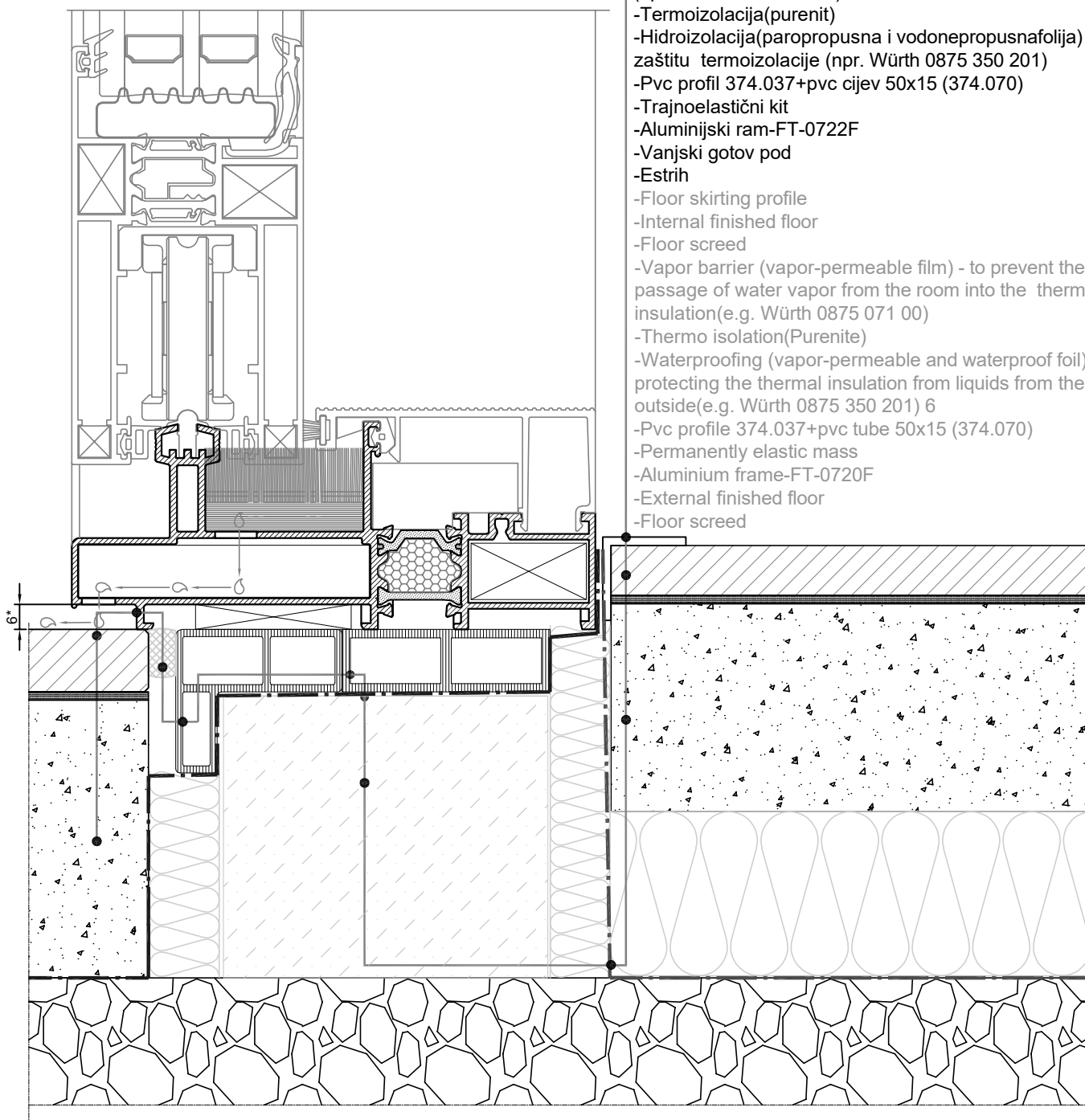

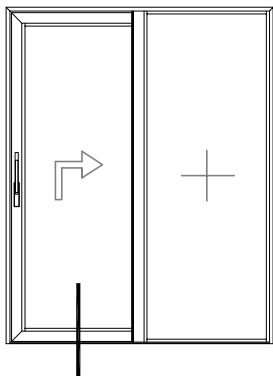

- Unutarnja završna obrada
- Fleksibilno građevinsko ljepilo
- Estrih
- Termoizolacija
- Paro i vodonepropusna folija (parna brana)
- Purenit - izolacijska ploča
- Paropropusna i vodonepropusna folija (hidroizolacija)
- Čepasta membrana (drenaža)
- Estrih
- Polimer-cementna hidroizolacija
- Fleksibilno građevinsko ljepilo
- Vanjski završni izgled (keramika / kamen)
- Internal finishing
- Flexible construction adhesive
- Screed
- Thermal insulation
- Vapour (Air tight) barrier (vapour and water proof tape), (eg. Iso Chemie: Iso-Connect Inside CX)
- Purenit (insulation board)+++
- Weather protection (vapourpermable and water proof tape) (eg. Iso Chemie: Iso-Connect Outside CX)+++
- Gutabetta membrane (drainage)+++
- Screed+++
- Polymer-cement weather protection+++
- Flexible construction adhesive+++
- Outside finishing (stone/ceramic)+++

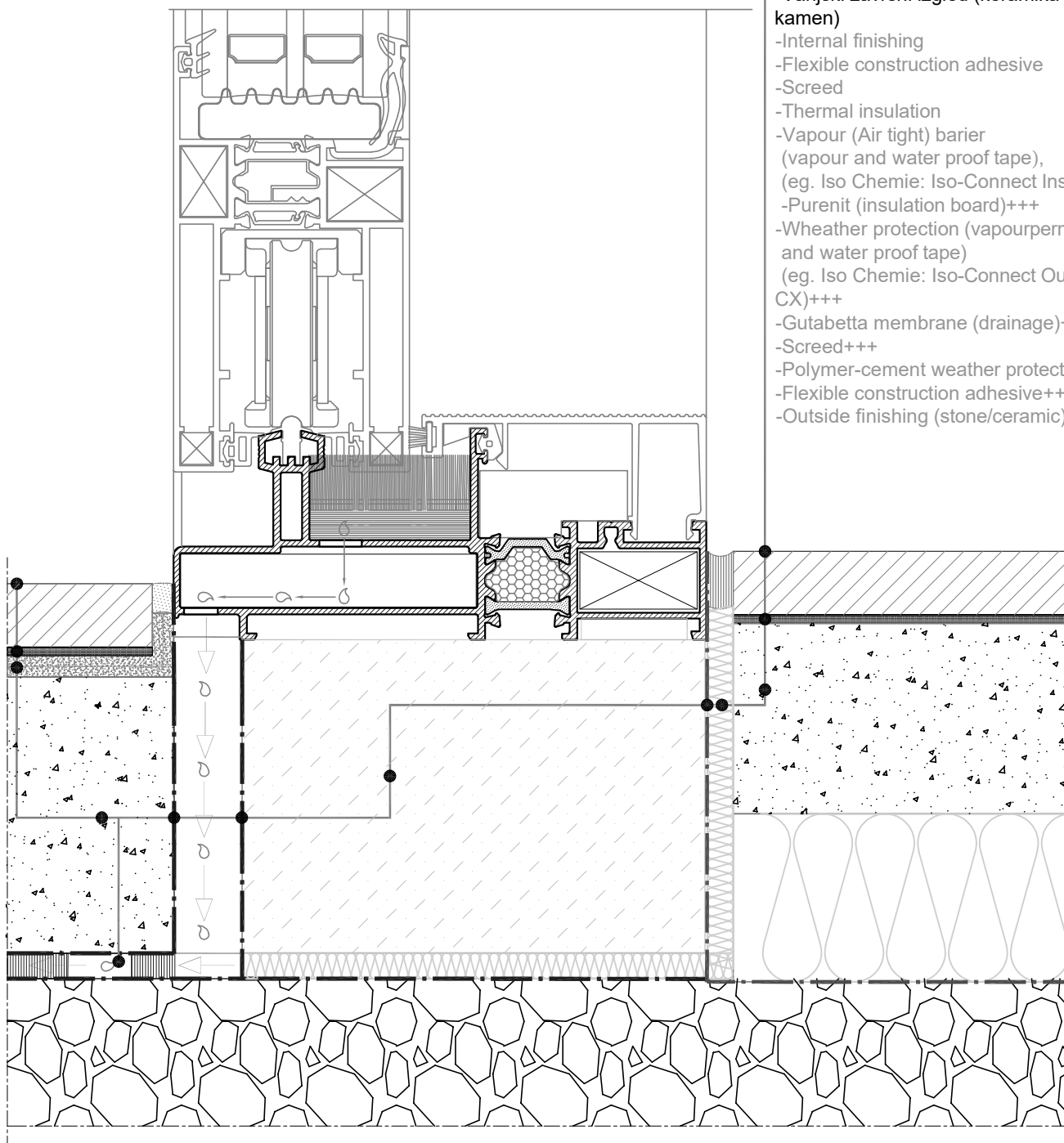

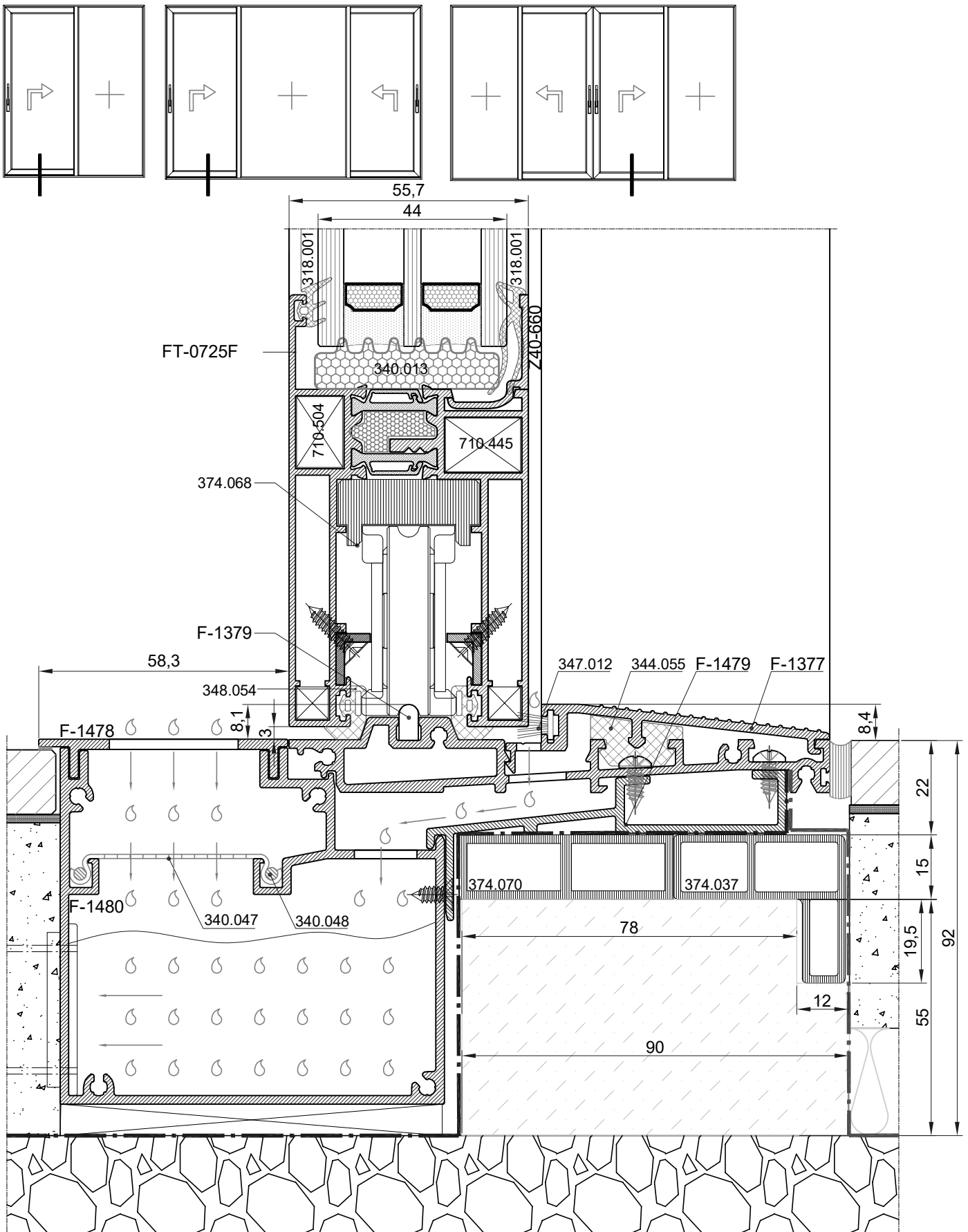

Napomena:

- Montaža vrata sa dodatnim profilom za sakupljanje kapljevina
- Visina praga u odnosu na kotu gotova poda 9 mm.

Remark:

- Installation of a door with an additional profile for collecting liquids
- The height of the threshold in relation to the elevation of the finished floor is 9 mm.

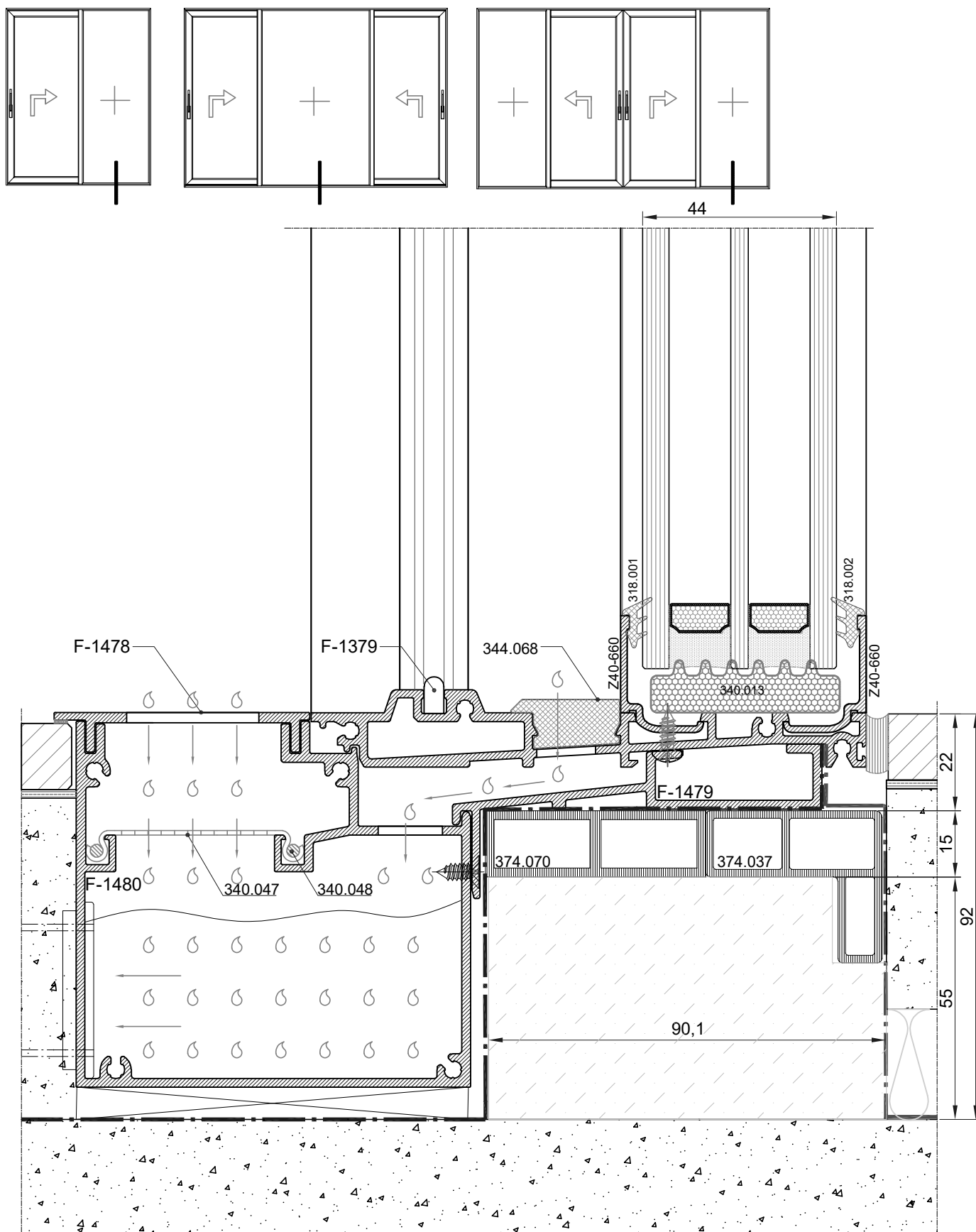

Napomena:

- Montaža vrata sa dodatnim profilom za sakupljanje kapljevina
- Visina praga u odnosu na kotu gotova poda 9 mm.

Remark:

- Installation of a door with an additional profile for collecting liquids
- The height of the threshold in relation to the elevation of the finished floor is 9 mm.

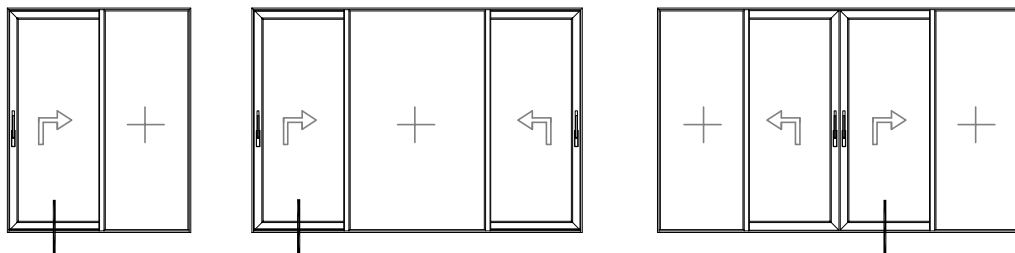

F-1478
maska
sakupljač
kapljevina

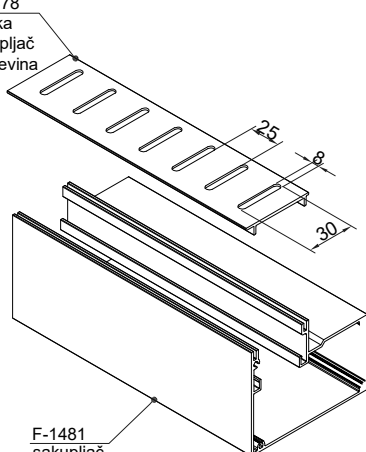

F-1481
sakupljač
kapljevina

F-1478

F-1480

0,0 -vanjska kota gotovog poda
0.0 - external elevation of the finished floor

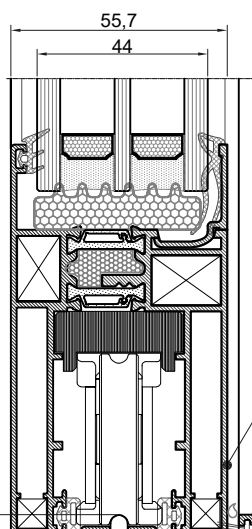

FT-0725F

F-1381

F-1377

F-1479

0,0 -unutarnja kota gotovog poda
0.0 - internal elevation of the finished floor

- Maska F-1478 (al profil perforirani)
- Mreža
- Brtva za fiksiranje mreže 340.048
- Profil F-1480 sakupljač kapljevina
- Profil F-1479 nastavak sakupljača kapljevina
- Hidroizolacija (paropropusna i vodonepropusna folija)
- Pvc profil 374.070 (50x15) + pvc profil 374.037
- Parna brana (paronepropusna folija)
- F-1377 al profil niski prag
- F-1381 al profil maska za niski prag
- Mask F-1478 (al profile perforated)
- Mesh
- Gasket for fixing the mesh 340.048
- Profile F-1480 liquid collector
- Profile F-1479 liquid collector extension
- Waterproofing (vapor-permeable and waterproof film)
- Pvc profil 374.070 (50x15) + pvc profil 374.037
- Vapor barrier (vapor-impermeable film)
- F-1377 al profile low threshold
- F-1381 al profile mask for low threshold

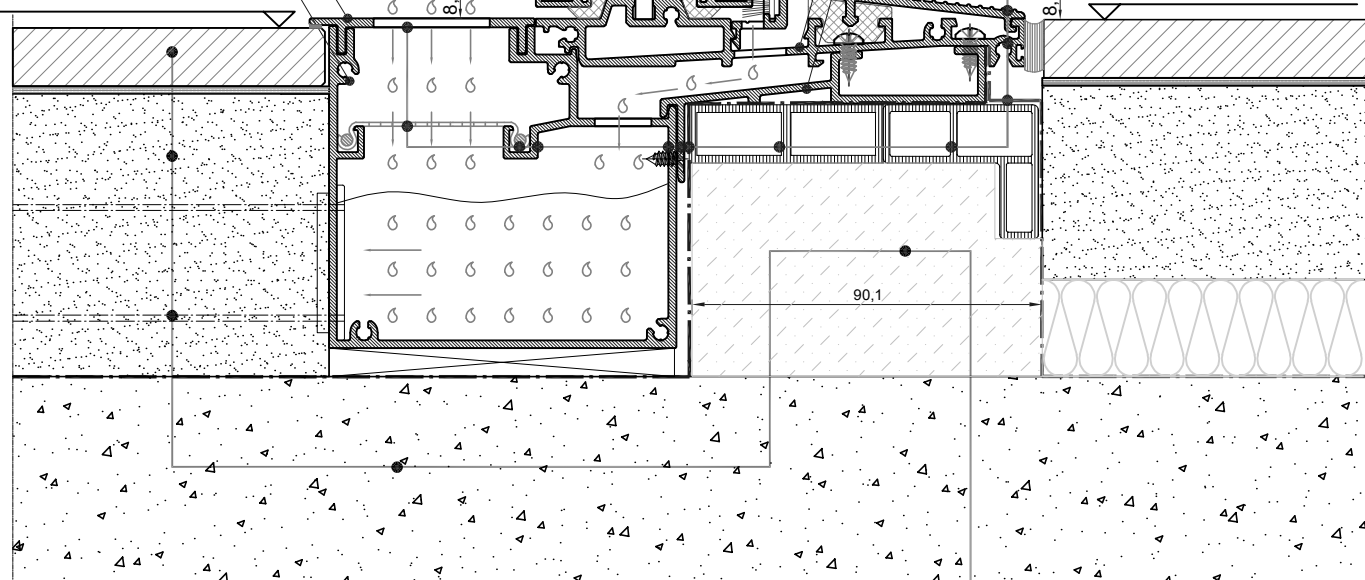

- Vanjski gotov pod
- Estrih
- Cijev za odvod kapljevina
- Beton
- Termoizolacija
- External finished floor
- Screed
- Drain pipe
- Concrete
- Thermal insulation

Napomena:

- Montaža vrata sa dodatnim profilom za sakupljanje kapljevina
- Visina praga u odnosu na kotu gotova poda 9 mm.

Remark:

- Installation of a door with an additional profile for collecting liquids
- The height of the threshold in relation to the elevation of the finished floor is 9 mm.

Prikaz odvodnje vode sa dodatnim profilom za sakupljanje kapljevina za klizne sistema (niske pragove do 10 mm):

- 1 - klizni sistemi (ugradnja sa visinom praga u odnosu na gotov pod do 10 mm)
- 2 - terasa
- 3 - cijev za odvod kapljevina iz kliznog sistema preko dodatnog profila za sakupljanje kroz estrih (preko terase) u svodnu cijev za oborinske vode
- 4 - svodne cijevi za oborinske vode

Display of water drainage with an additional profile for collecting liquids for sliding systems (low thresholds up to 10 mm): ①

- 1 - sliding systems (installation with threshold height in relation to the finished floor up to 10 mm)
- 2 - terrace
- 3 - pipe for draining liquids from the sliding system via an additional profile for collection through the screed (over the terrace) into the rainwater downpipe
- 4 - downpipes for rainwater

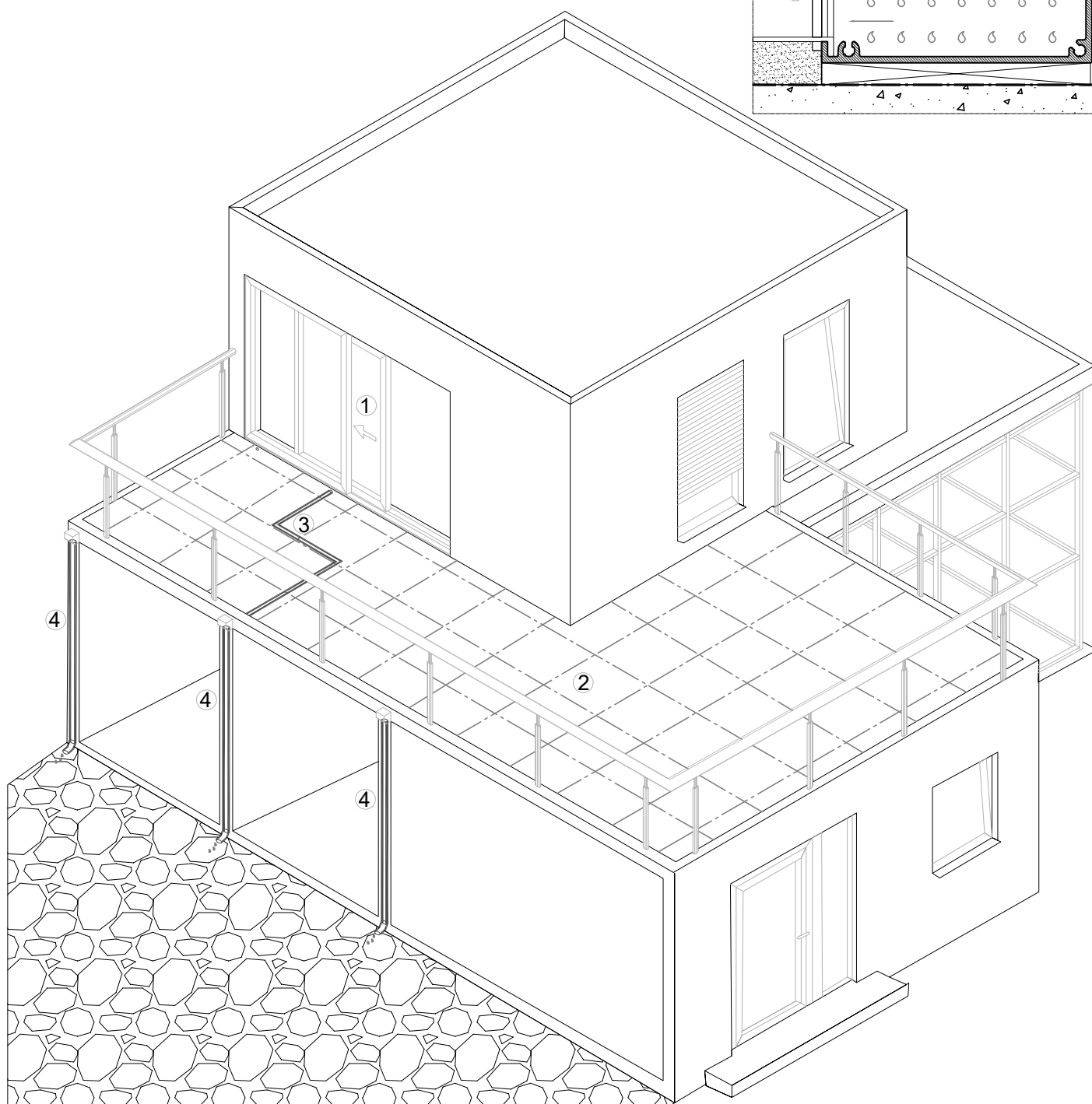
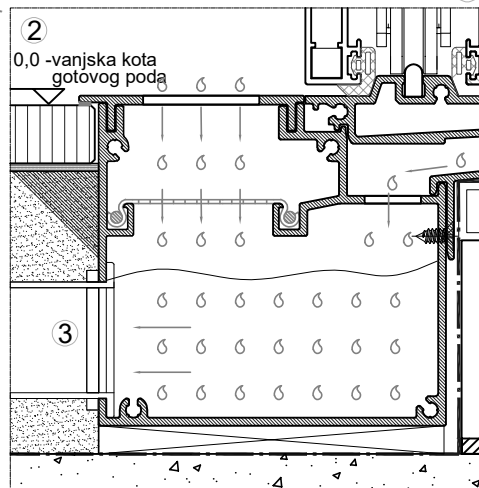

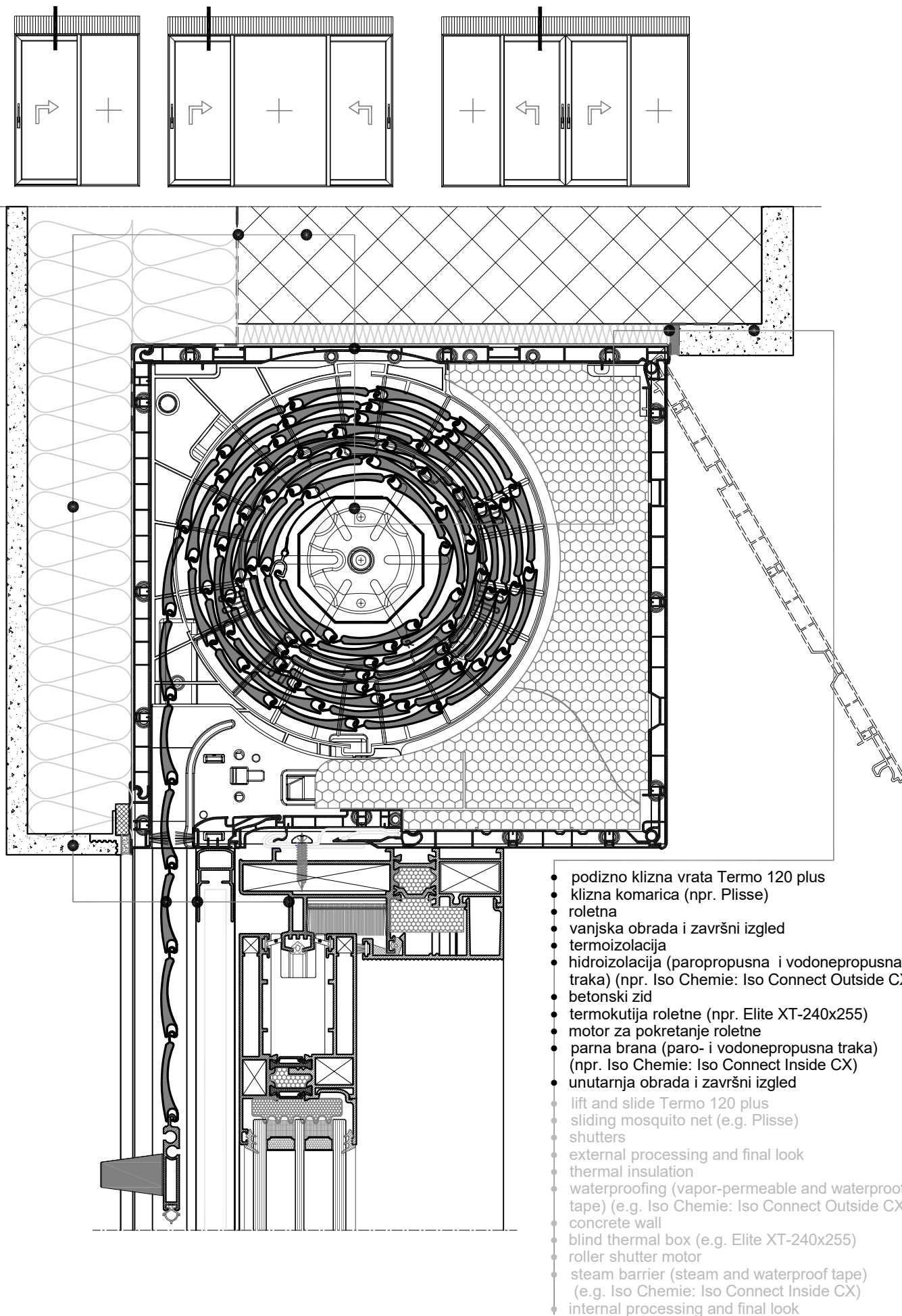

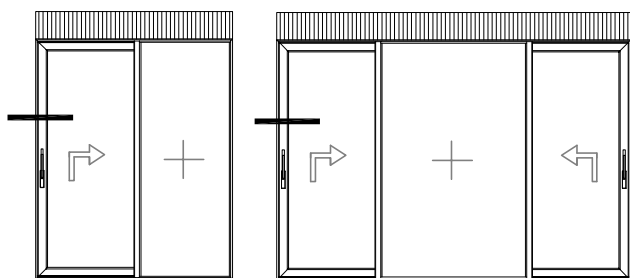

- betonski zid
- hidroizolacija (paropropusna i vodonepropusna traka) (npr. Iso Chemie: Iso Connect Outside CX)
- termoizolacija
- vanjska obrada i završni izgled
- vodilica roletne
- klizna komarica (npr. Plisse)
- podizno klizna vrata Termo 120 plus
- al profil F-1671
- XPS ispuna
- termoizolacija (exp.spužvica: Iso Chemie: ISO Bloco One)
- parna brana (paro- i vodonepropusna traka) (npr. Iso Chemie: Iso Connect Inside CX)
- unutarnja obrada i završni izgled
- al profil F-1672
- concrete wall
- weather protection (vapourpermeable and water proof tape) (eg. Iso Chemie: Iso-Connect Outside CX)
- thermal insulation
- outside finish
- roller shutter profile
- sliding mosquitoes (eg. Plise)
- lift and slide door Termo 120 plus
- al profile F-1671
- XPS infill
- thermal insulation (Expanding joint sealing foam tape: Iso Chemie ISO Bloco One)
- vapour (Air tight) barrier (vapour and water proof tape), (eg. Iso Chemie: Iso-Connect Inside CX)
- inside finis
- al profile F-1672

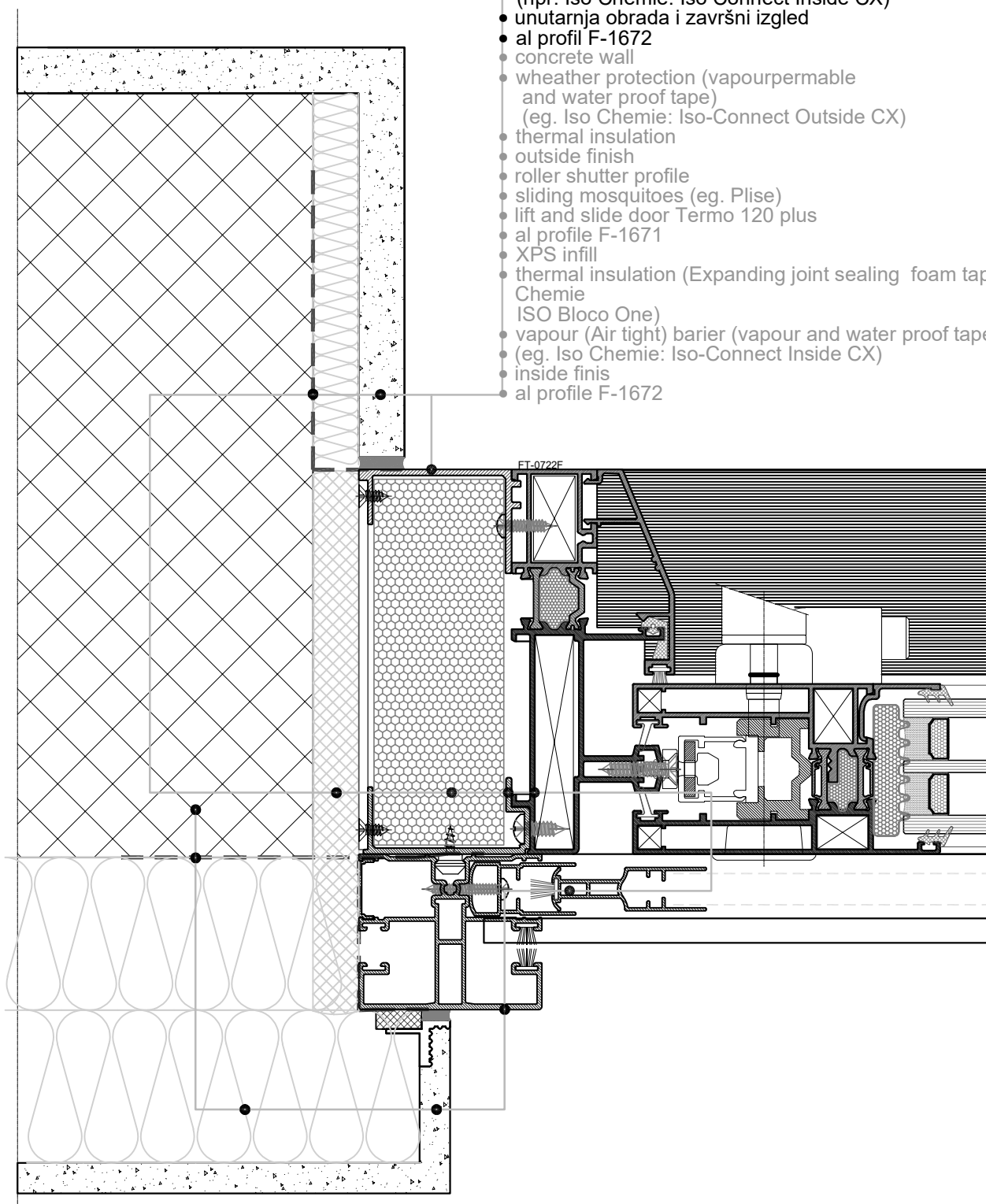

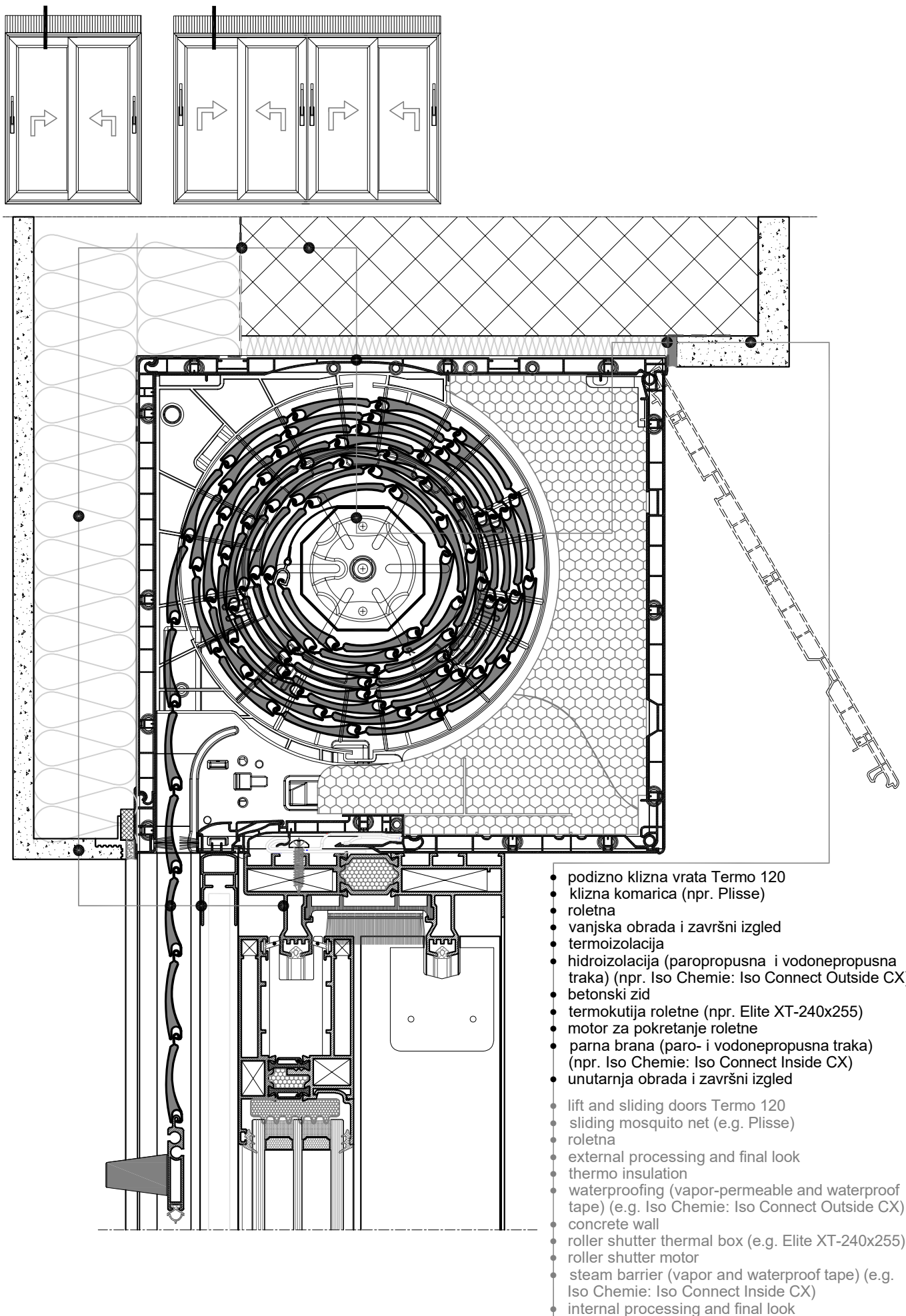

- podizno klizna vrata Termo 120
- klizna komarica (npr. Plisse)
- roletna
- vanjska obrada i završni izgled
- termoizolacija
- hidroizolacija (paropropusna i vodonepropusna traka) (npr. Iso Chemie: Iso Connect Outside CX)
- betonski zid
- termokutija roletne (npr. Elite XT-240x255)
- motor za pokretanje roletne
- parna brana (paro- i vodonepropusna traka) (npr. Iso Chemie: Iso Connect Inside CX)
- unutarnja obrada i završni izgled
- lift and sliding doors Termo 120
- sliding mosquito net (e.g. Plisse)
- roletna
- external processing and final look
- thermo insulation
- waterproofing (vapor-permeable and waterproof tape) (e.g. Iso Chemie: Iso Connect Outside CX)
- concrete wall
- roller shutter thermal box (e.g. Elite XT-240x255)
- roller shutter motor
- steam barrier (vapor and waterproof tape) (e.g. Iso Chemie: Iso Connect Inside CX)
- internal processing and final look

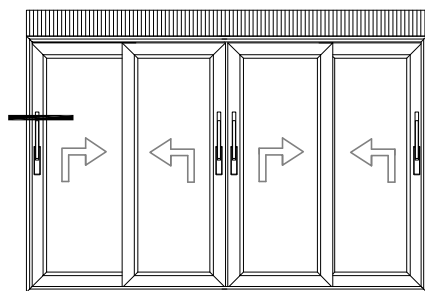
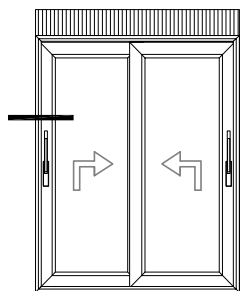

- betonski zid
- hidroizolacija (paropropusna i vodonepropusna traka) (npr. Iso Chemie: Iso Connect Outside CX)
- termoizolacija
- vanjska obrada i završni izgled
- vodilica roletne
- klizna komarica (npr. Plisse)
- podizno klizna vrata Termo 150 plus
- al profil F-1669
- XPS ispuna
- termoizolacija (exp.spužvica: Iso Chemie: ISO Bloco One)
- parna brana (paro- i vodonepropusna traka) (npr. Iso Chemie: Iso Connect Inside CX)
- unutarnja obrada i završni izgled
- al profil F-1669
- concrete wall
- weather protection (vapourpermeable and water proof tape) (eg. Iso Chemie: Iso-Connect Outside CX)
- thermal insulation
- outside finish
- roller shutter profile
- sliding mosquitoes (eg. Plisse)
- lift and slide door Termo 150 plus
- al profile F-1669
- XPS infill
- thermal insulation (Expanding joint sealing foam tape: Iso Chemie ISO Bloco One)
- vapour (Air tight) barrier (vapour and water proof tape), (eg. Iso Chemie: Iso-Connect Inside CX)
- inside finish
- al profile F-1669

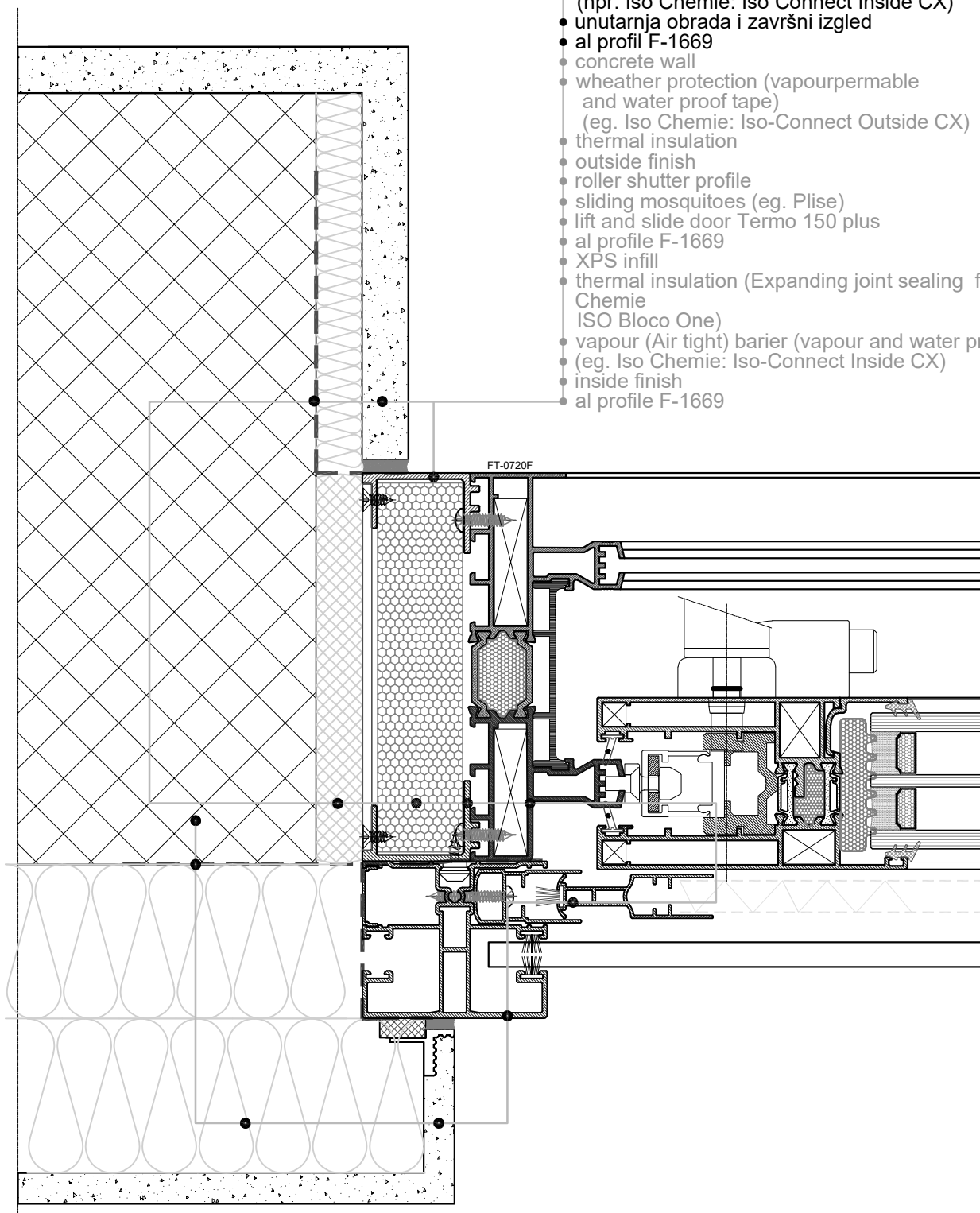

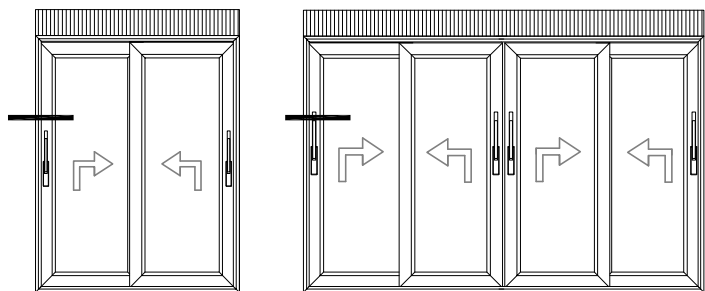

- betonski zid
- hidroizolacija (paropropusna i vodonepropusna traka) (npr. Iso Chemie: Iso Connect Outside CX)
- termoizolacija
- vanjska obrada i završni izgled
- vodilica roletne
- klizna komarica (npr. Plisse)
- podizno klizna vrata Termo 150 plus
- al profil F-1672
- XPS ispuna
- termoizolacija (exp.spužvica: Iso Chemie: ISO Bloco One)

- parna brana (paro- i vodonepropusna traka) (npr. Iso Chemie: Iso Connect Inside CX)
- unutarnja obrada i završni izgled
- al profil F-1672
- concrete wall
- weather protection (vapourpermeable and water proof tape) (eg. Iso Chemie: Iso-Connect Outside CX)
- thermal insulation
- outside finish
- roller shutter profile
- sliding mosquitoes (eg. Plisse)
- lift and slide door Termo 150 plus
- al profile F-1672
- XPS infill
- thermal insulation (Expanding joint sealing foam tape: Iso Chemie ISO Bloco One)
- vapour (Air tight) barrier (vapour and water proof tape), (eg. Iso Chemie: Iso-Connect Inside CX)
- inside finish
- al profile F-1672

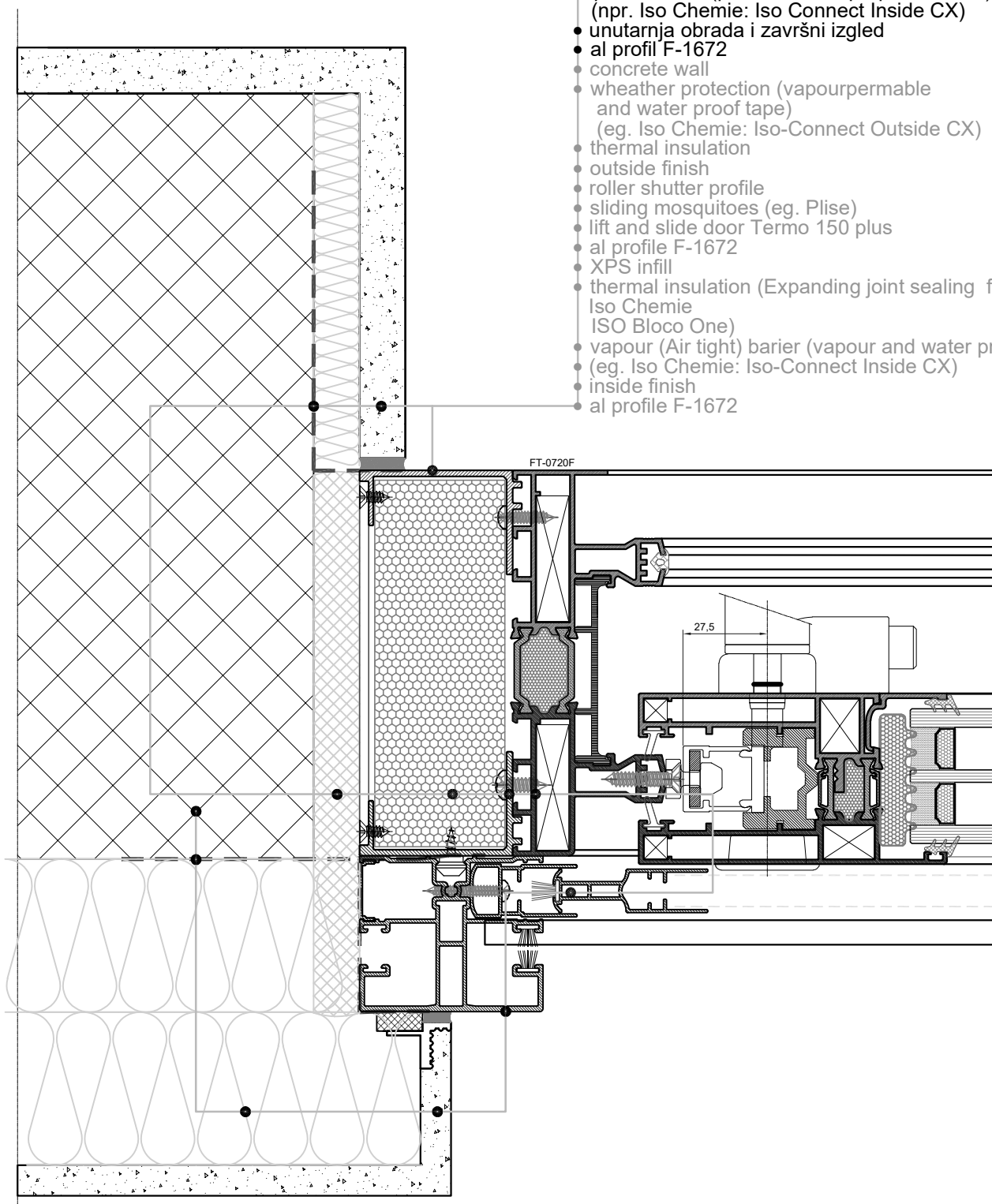

FEAL



Skenirajte QR kod i registrirajte se na partner.feal.ba

Scan the QR code and register on partner.feal.ba

TERMO 120

Knjiga A / *Book A*

Travanj 2025. / April 2025.

FEAL d.o.o.
Trnska cesta 146
88220 Široki Brijeg
Bosna i Hercegovina
Tel. +387 39 704-269; 705-807; 705-636
Fax. +387 39 704-358
info@feal.ba
www.feal.ba