

# FEAL



OF 60

ALUMINIJSKA OGRADA  
*ALUMINIUM FENCE*



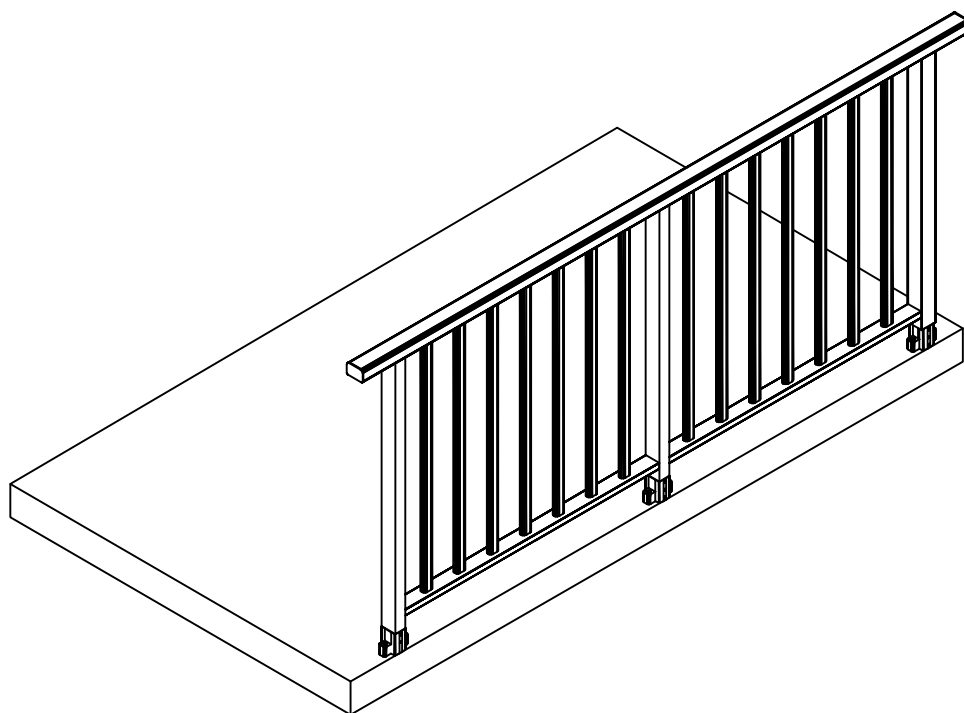
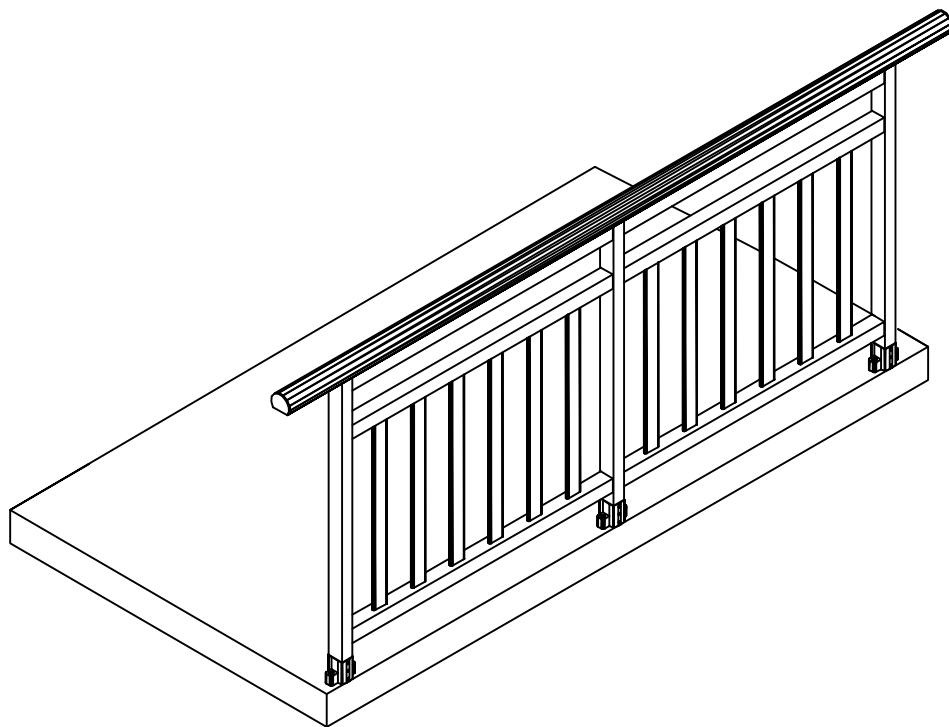

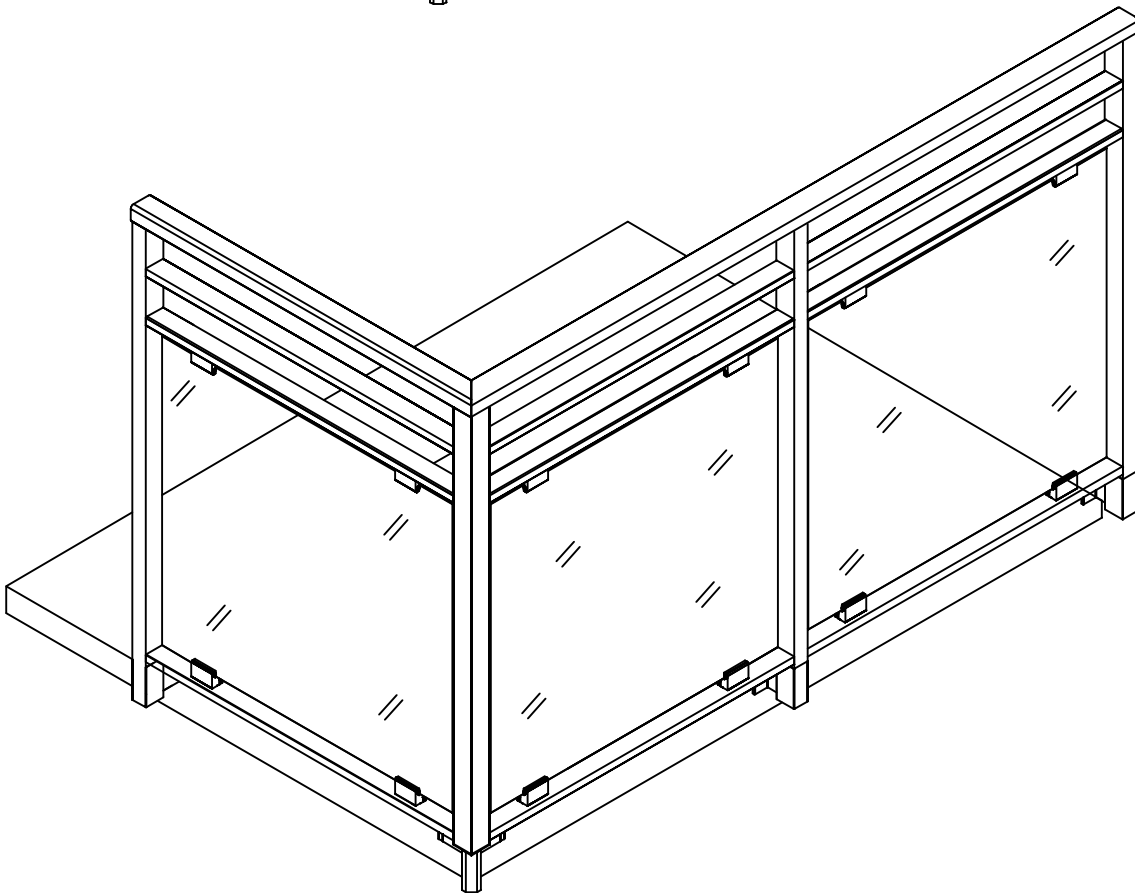
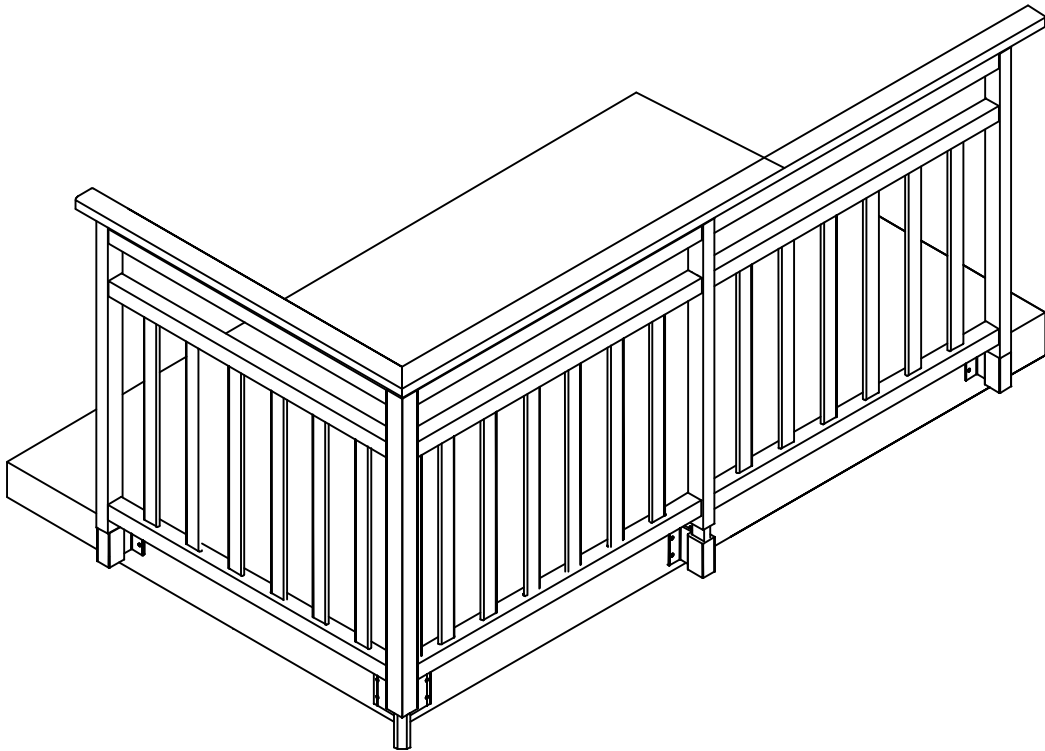

## SADRŽAJ - KAZALO

02	Profili	701.03.000-013
03	Vezni elementi	701.04.000-007
04	PVC komponente	701.05.000-003
05	Presjeci	701.10.000-025
06	Obrada i montaža	701.11.000-057
07	Rezne liste	701.12.000-005

---

---

# Profili



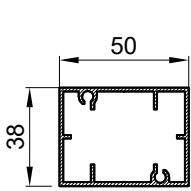

**OG-101**  
kg/m 0.854

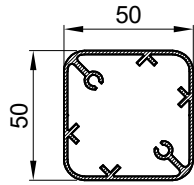

**OG-102**  
kg/m 1.056

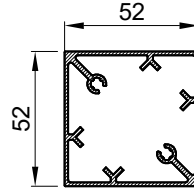

**F-1247**  
kg/m 1.209

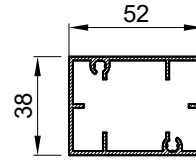

**F-1246**  
kg/m 0.892

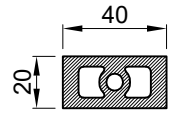

**F-0200**  
kg/m 1.499

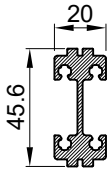

**F-1855**  
kg/m 1.0097

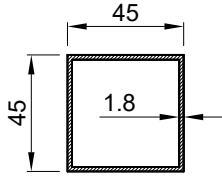

**F-0048**  
kg/m 0.840

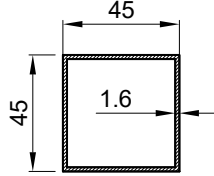

**F-0048/A**  
kg/m 0.750

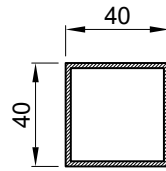

**F-0174**  
kg/m 0.829

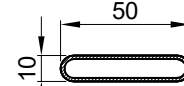

**F-0187**  
kg/m 0.397

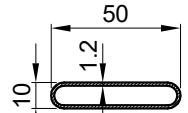

**F-0187/A**  
kg/m 0.349

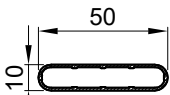

**F-0187/L**  
kg/m 0.307

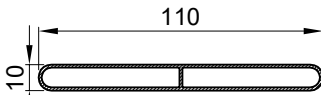

**F-1068**  
kg/m 0.760

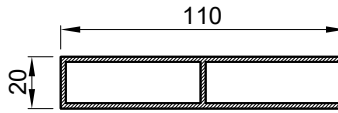

**F-0062**  
kg/m 1.45

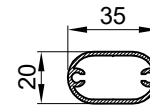

**OG-111**  
kg/m 0.440

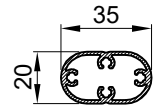

**F-1849**  
kg/m 0.5

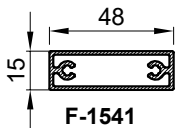

**F-1541**  
kg/m 0.618

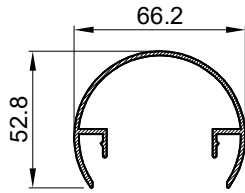

**F-0621**  
kg/m 0.831

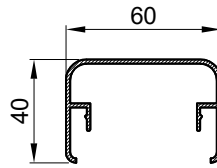

**F-0689**  
kg/m 0.740

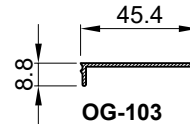

**OG-103**  
kg/m 0.224

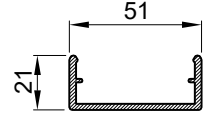

**F-0620**  
kg/m 0.619

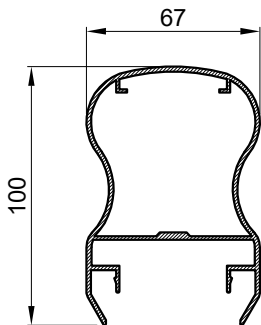

**F-0673/A**  
kg/m 1.735

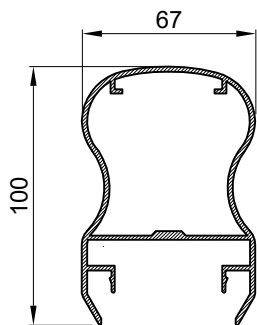

**F-0673**  
kg/m 1.925

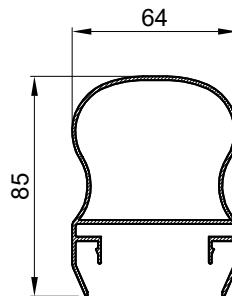

**F-1334**  
kg/m 1.185

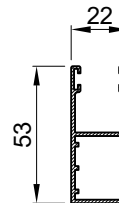

**F-0608**  
kg/m 0.607

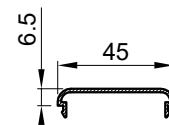

**M45-756**  
kg/m 0.225

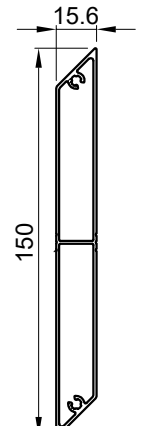

**F-1845**  
kg/m 1.1313



**F-1096**  
kg/m 0.970

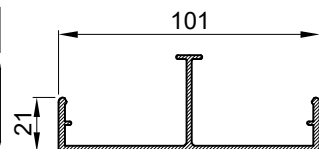

**F-1097**  
kg/m 1.148

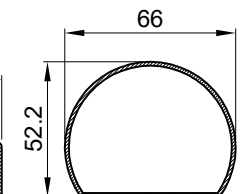

**F-1191**  
kg/m 0.784

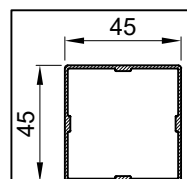

**F-1192**  
kg/m 0.630

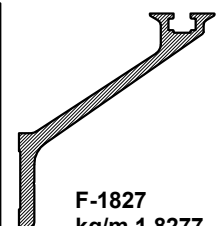

**F-1827**  
kg/m 1.8277



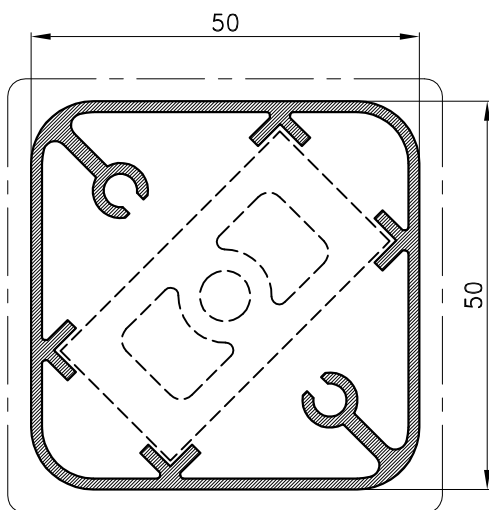

Profil		
Art.-Br.	<b>OG-102</b>	
Težina	kg/m	<b>1.056</b>
Opseg	mm	186
Moment inercije	I <sub>x</sub> (cm <sup>4</sup> )	13.25
	I <sub>y</sub> (cm <sup>4</sup> )	13.26
	W <sub>x</sub> (cm <sup>4</sup> )	5.30
	W <sub>y</sub> (cm <sup>4</sup> )	5.30
Dužina isporuke	mm	6500

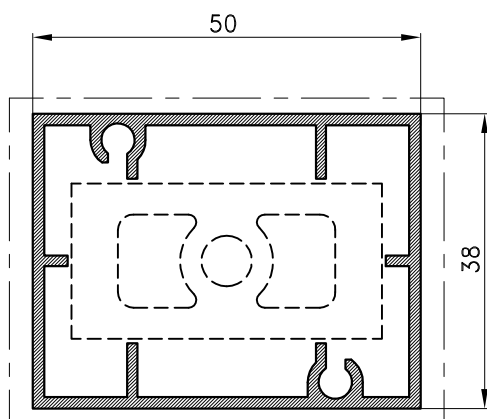

Profil		
Art.-Br.	<b>OG-101</b>	
Težina	kg/m	<b>0.854</b>
Opseg	mm	176
Moment inercije	I <sub>x</sub> (cm <sup>4</sup> )	7.1990
	I <sub>y</sub> (cm <sup>4</sup> )	10.6421
	W <sub>x</sub> (cm <sup>4</sup> )	3.7869
	W <sub>y</sub> (cm <sup>4</sup> )	4.2568
Dužina isporuke	mm	6500

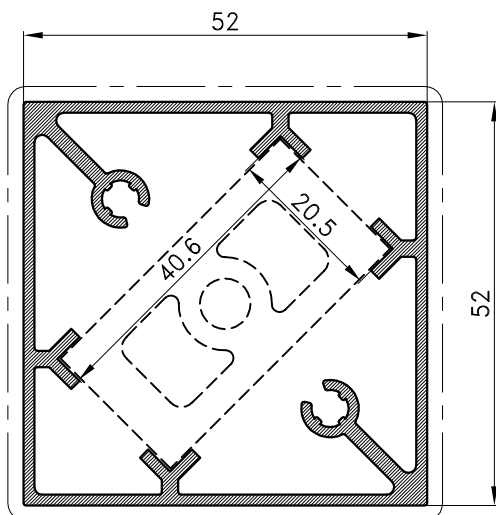

Profil		
Art.-Br.	<b>F-1247</b>	
Težina	kg/m	<b>1.209</b>
Opseg	mm	207.5
Moment inercije	I <sub>x</sub> (cm <sup>4</sup> )	16.95
	I <sub>y</sub> (cm <sup>4</sup> )	16.95
	W <sub>x</sub> (cm <sup>4</sup> )	6.52
	W <sub>y</sub> (cm <sup>4</sup> )	6.52
Dužina isporuke	mm	6500

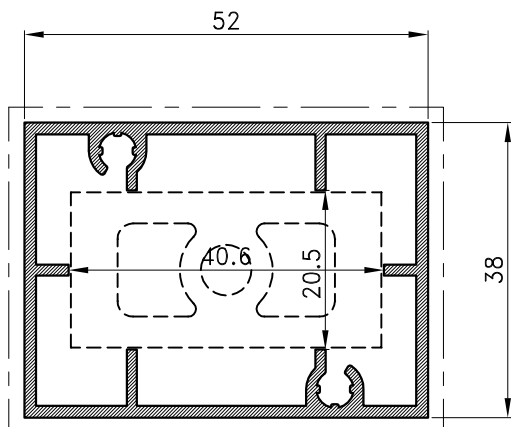

Profil		
Art.-Br.	<b>F-1246</b>	
Težina	kg/m	<b>0.892</b>
Opseg	mm	180
Moment inercije	$I_x$ (cm <sup>4</sup> )	7.47
	$I_y$ (cm <sup>4</sup> )	11.83
	$W_x$ (cm <sup>4</sup> )	3.39
	$W_y$ (cm <sup>4</sup> )	4.55
Dužina isporuke	mm	6500

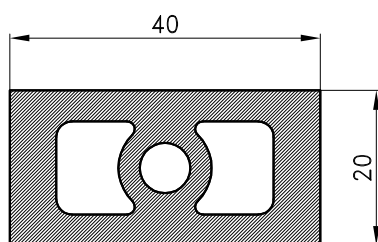

Profil		
Art.-Br.	<b>F-0200</b>	
Težina	kg/m	<b>1.499</b>
Opseg	mm	120
Moment inercije	$I_x$ (cm <sup>4</sup> )	2.39
	$I_y$ (cm <sup>4</sup> )	8.63
	$W_x$ (cm <sup>4</sup> )	2.39
	$W_y$ (cm <sup>4</sup> )	4.31
Dužina isporuke	mm	6500

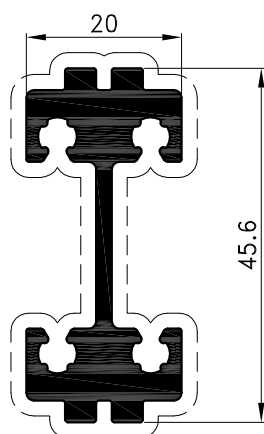

Profil		
Art.-Br.	<b>F-1855</b>	
Težina	kg/m	<b>1.0097</b>
Opseg	mm	224.91
Moment inercije	$I_x$ (cm <sup>4</sup> )	9.63
	$I_y$ (cm <sup>4</sup> )	0.96
	$W_x$ (cm <sup>4</sup> )	4.22
	$W_y$ (cm <sup>4</sup> )	0.96
Dužina isporuke	mm	6500

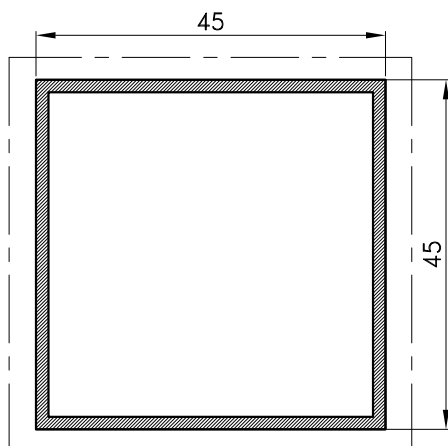

Profil		
Art.-Br.	<b>F-0048/A</b>	
Težina	kg/m	<b>0.750</b>
Opseg	mm	180
Moment inercije	$I_x$ (cm <sup>4</sup> )	8.73
	$I_y$ (cm <sup>4</sup> )	8.73
	$W_x$ (cm <sup>4</sup> )	3.88
	$W_y$ (cm <sup>4</sup> )	3.88
Dužina isporuke	mm	6000

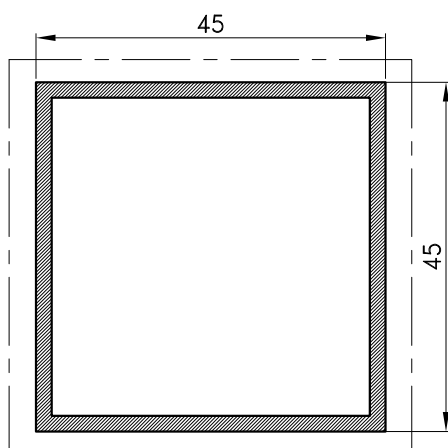

Profil		
Art.-Br.	<b>F-0048</b>	
Težina	kg/m	<b>0.84</b>
Opseg	mm	180
Moment inercije	$I_x$ (cm <sup>4</sup> )	10.62
	$I_y$ (cm <sup>4</sup> )	10.62
	$W_x$ (cm <sup>4</sup> )	4.72
	$W_y$ (cm <sup>4</sup> )	4.72
Dužina isporuke	mm	6500

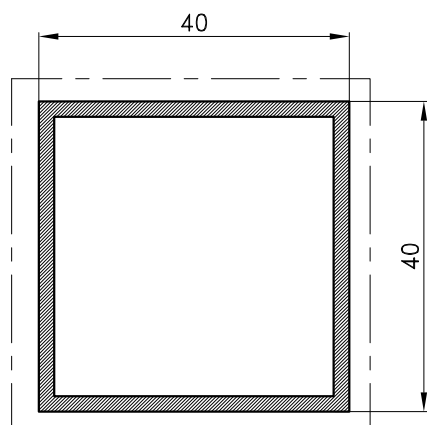

Profil		
Art.-Br.	<b>F-0174</b>	
Težina	kg/m	<b>0.829</b>
Opseg	mm	160
Moment inercije	$I_x$ (cm <sup>4</sup> )	7.34
	$I_y$ (cm <sup>4</sup> )	7.34
	$W_x$ (cm <sup>4</sup> )	3.67
	$W_y$ (cm <sup>4</sup> )	3.67
Dužina isporuke	mm	6000

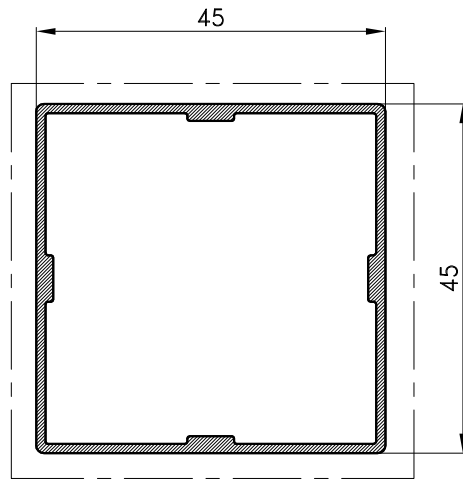

Profil		
Art.-Br.	<b>F-1192</b>	
Težina	kg/m	<b>0.630</b>
Opseg	mm	180
Moment inercije	$I_x$ (cm <sup>4</sup> )	7.21
	$I_y$ (cm <sup>4</sup> )	7.21
	$W_x$ (cm <sup>4</sup> )	3.20
	$W_y$ (cm <sup>4</sup> )	3.20
Dužina isporuke	mm	6000

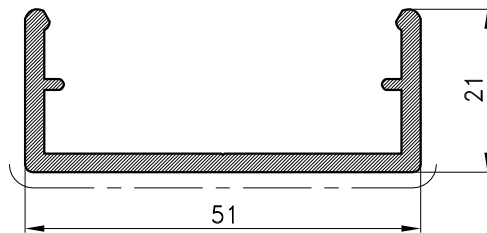

Profil		
Art.-Br.	<b>F-0620</b>	
Težina	kg/m	<b>0.600</b>
Opseg	mm	188
Moment inercije	$I_x$ (cm <sup>4</sup> )	0.88
	$I_y$ (cm <sup>4</sup> )	8.43
	$W_x$ (cm <sup>4</sup> )	0.58
	$W_y$ (cm <sup>4</sup> )	3.31
Dužina isporuke	mm	6500

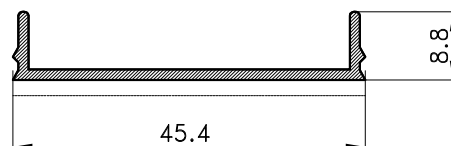

Profil		
Art.-Br.	<b>OG-103</b>	
Težina	kg/m	<b>0.224</b>
Opseg	mm	122
Moment inercije	$I_x$ (cm <sup>4</sup> )	0.04
	$I_y$ (cm <sup>4</sup> )	1.97
	$W_x$ (cm <sup>4</sup> )	0.05
	$W_y$ (cm <sup>4</sup> )	0.87
Dužina isporuke	mm	6500

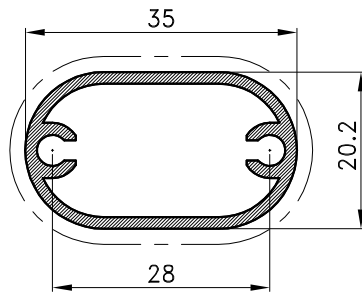

Profil		
Art.-Br.	<b>OG-111</b>	
Težina	kg/m	<b>0.44</b>
Opseg	mm	93
Moment inercije	$I_x$ (cm <sup>4</sup> )	0.78
	$I_y$ (cm <sup>4</sup> )	2.28
	$W_x$ (cm <sup>4</sup> )	0.78
	$W_y$ (cm <sup>4</sup> )	1.30
Dužina isporuke	mm	6500

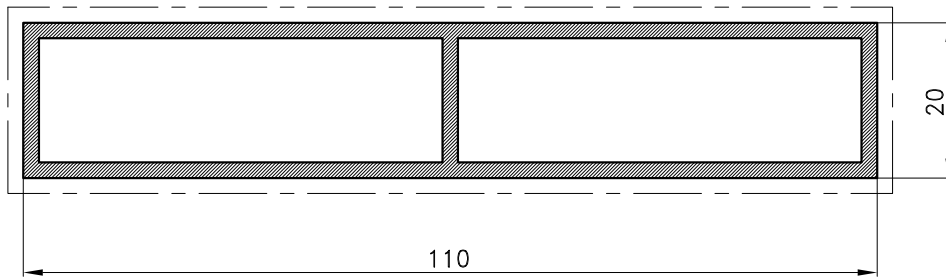

Profil		
Art.-Br.	<b>F-0062</b>	
Težina	kg/m	<b>1.45</b>
Opseg	mm	260
Moment inercije	$I_x$ (cm <sup>4</sup> )	3.78
	$I_y$ (cm <sup>4</sup> )	63.03
	$W_x$ (cm <sup>4</sup> )	3.78
	$W_y$ (cm <sup>4</sup> )	11.46
Dužina isporuke	mm	6500

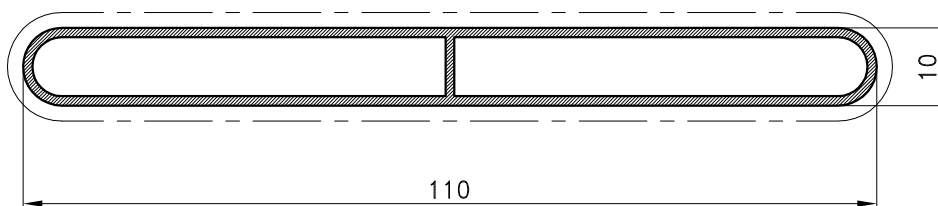

Profil		
Art.-Br.	<b>F-1068</b>	
Težina	kg/m	<b>0.760</b>
Opseg	mm	231
Moment inercije	$I_x$ (cm <sup>4</sup> )	0.50
	$I_y$ (cm <sup>4</sup> )	29.26
	$W_x$ (cm <sup>4</sup> )	1.01
	$W_y$ (cm <sup>4</sup> )	5.32
Dužina isporuke	mm	6500

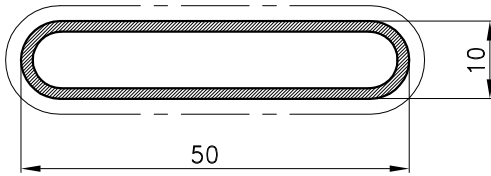

Profil		
Art.-Br.	<b>F-0187</b>	
Težina	kg/m	<b>0.397</b>
Opseg	mm	111
Moment inercije	$I_x$ (cm <sup>4</sup> )	0.24
	$I_y$ (cm <sup>4</sup> )	3.46
	$W_x$ (cm <sup>4</sup> )	0.48
	$W_y$ (cm <sup>4</sup> )	1.39
Dužina isporuke	mm	6500

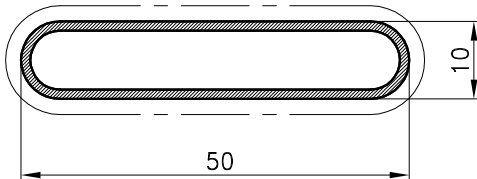

Profil		
Art.-Br.	<b>F-0187/A</b>	
Težina	kg/m	<b>0.349</b>
Opseg	mm	111
Moment inercije	$I_x$ (cm <sup>4</sup> )	0.21
	$I_y$ (cm <sup>4</sup> )	3.01
	$W_x$ (cm <sup>4</sup> )	0.43
	$W_y$ (cm <sup>4</sup> )	1.20
Dužina isporuke	mm	6500

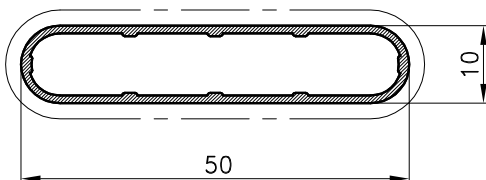

Profil		
Art.-Br.	<b>F-0187/L</b>	
Težina	kg/m	<b>0.307</b>
Opseg	mm	111
Moment inercije	$I_x$ (cm <sup>4</sup> )	0.20
	$I_y$ (cm <sup>4</sup> )	2.66
	$W_x$ (cm <sup>4</sup> )	0.39
	$W_y$ (cm <sup>4</sup> )	1.07
Dužina isporuke	mm	6500

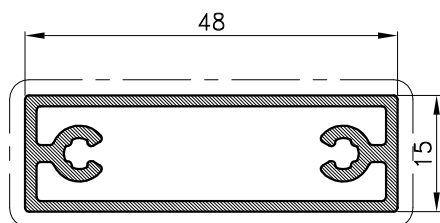

Profil		
Art.-Br.	<b>F-1541</b>	
Težina	kg/m	<b>0.618</b>
Opseg	mm	186
Moment inercije	I <sub>x</sub> (cm <sup>4</sup> )	6.49
	I <sub>y</sub> (cm <sup>4</sup> )	0.69
	W <sub>x</sub> (cm <sup>4</sup> )	2.70
	W <sub>y</sub> (cm <sup>4</sup> )	0.92
Dužina isporuke	mm	6500

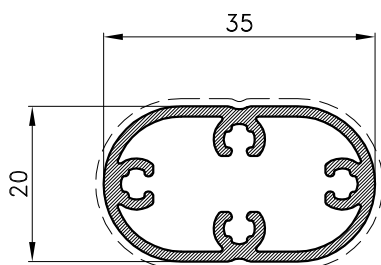

Profil		
Art.-Br.	<b>F-1849</b>	
Težina	kg/m	<b>0.5</b>
Opseg	mm	93.1
Moment inercije	I <sub>x</sub> (cm <sup>4</sup> )	0.83
	I <sub>y</sub> (cm <sup>4</sup> )	2.22
	W <sub>x</sub> (cm <sup>4</sup> )	0.83
	W <sub>y</sub> (cm <sup>4</sup> )	1.27
L	mm	6500

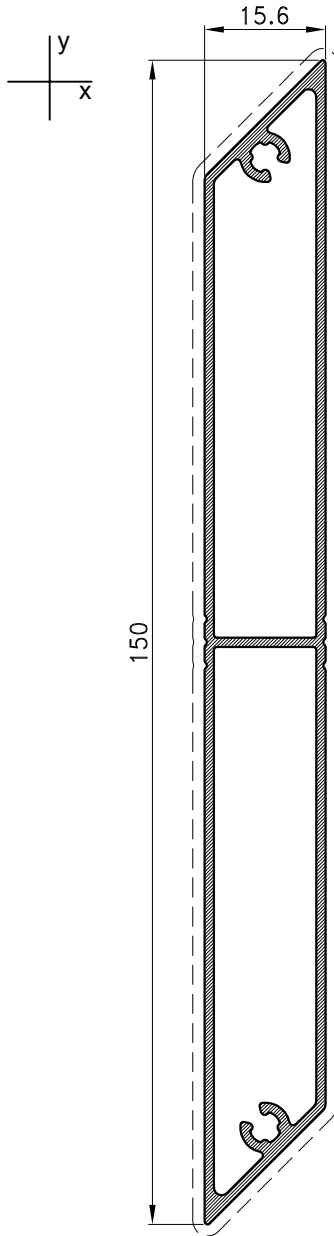

Profil		
Art.-Br.	<b>F-1845</b>	
Težina	kg/m	<b>1.1313</b>
Opseg	mm	314.32
Moment inercije	$I_x$ (cm <sup>4</sup> )	85.28
	$I_y$ (cm <sup>4</sup> )	1.79
	$W_x$ (cm <sup>4</sup> )	11.37
	$W_y$ (cm <sup>4</sup> )	2.29
Dužina isporuke	mm	6500

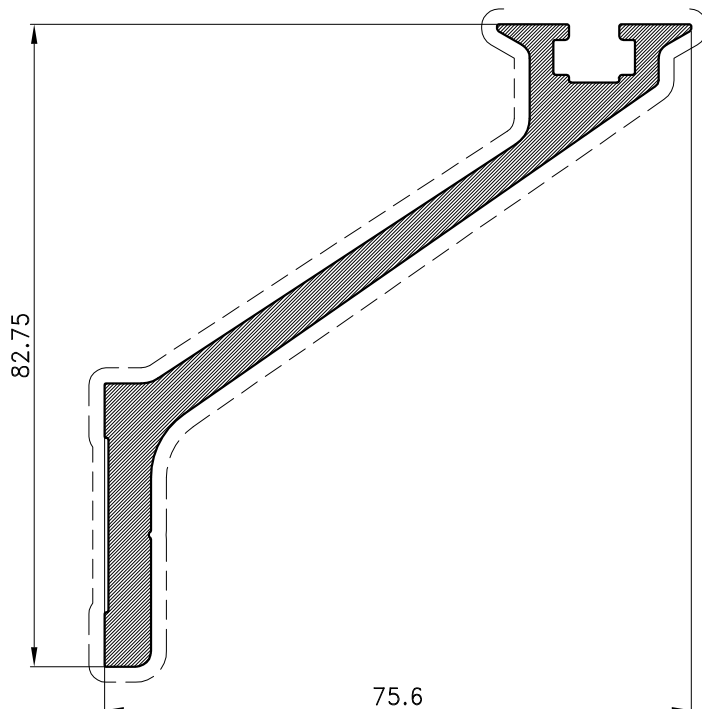

Profil		
Art.-Br.	<b>F-1827</b>	
Težina	kg/m	<b>1.8277</b>
Opseg	mm	287.16
Moment inercije	$I_x$ (cm <sup>4</sup> )	36.21
	$I_y$ (cm <sup>4</sup> )	38.89
	$W_x$ (cm <sup>4</sup> )	7.87
	$W_y$ (cm <sup>4</sup> )	8.41
Dužina isporuke	mm	6500

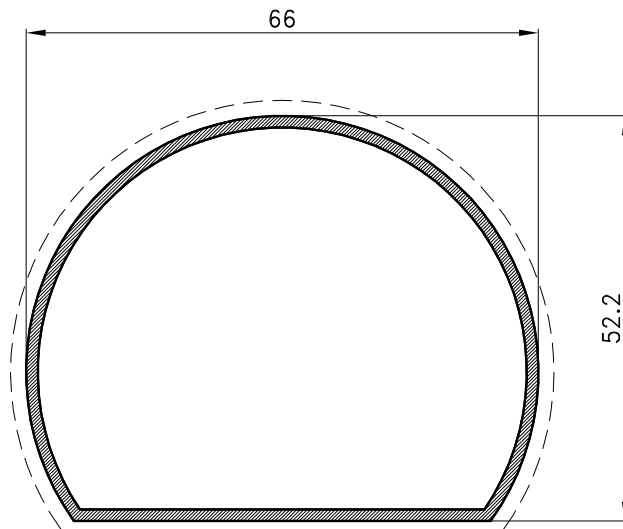

Profil		
Art.-Br.	<b>F-1191</b>	
Težina	kg/m	<b>0.784</b>
Opseg	mm	198.34
Moment inercije	I <sub>x</sub> (cm <sup>4</sup> )	10.90
	I <sub>y</sub> (cm <sup>4</sup> )	15.18
	W <sub>x</sub> (cm <sup>4</sup> )	3.73
	W <sub>y</sub> (cm <sup>4</sup> )	4.60
Dužina isporuke	mm	6500

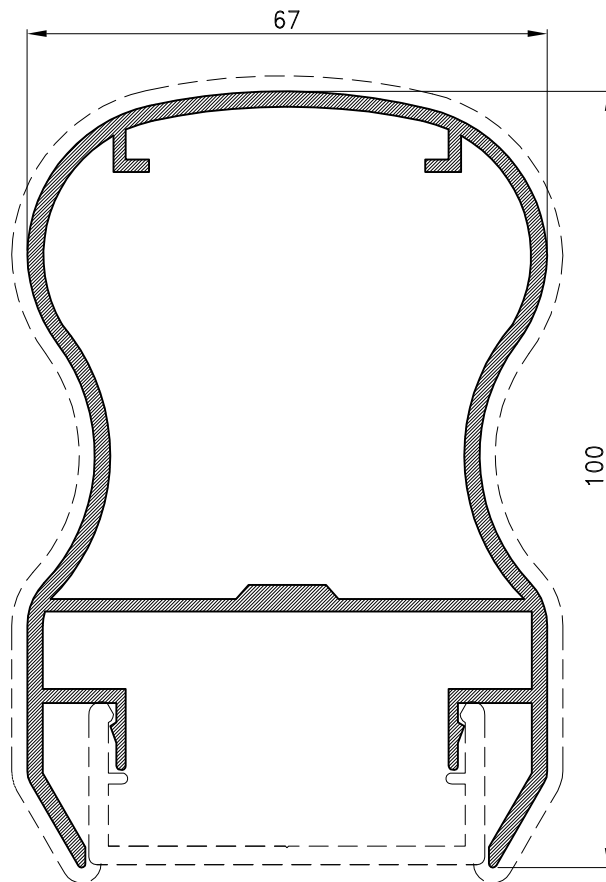

Profil		
Art.-Br.	<b>F-0673</b>	
Težina	kg/m	<b>1.925</b>
Opseg	mm	469
Moment inercije	I <sub>x</sub> (cm <sup>4</sup> )	66.23
	I <sub>y</sub> (cm <sup>4</sup> )	44.90
	W <sub>x</sub> (cm <sup>4</sup> )	12.74
	W <sub>y</sub> (cm <sup>4</sup> )	13.39
Dužina isporuke	mm	6500

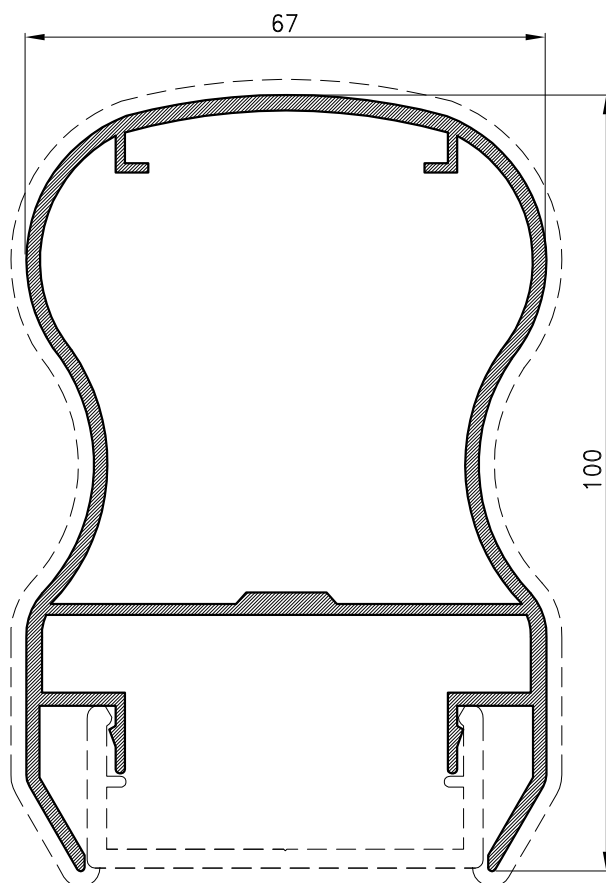

Profil		
Art.-Br.	<b>F-0673/A</b>	
Težina	kg/m	<b>1.735</b>
Opseg	mm	470
Moment inercije	$I_x$ (cm <sup>4</sup> )	60.76
	$I_y$ (cm <sup>4</sup> )	40.48
	$W_x$ (cm <sup>4</sup> )	11.66
	$W_y$ (cm <sup>4</sup> )	12.08
Dužina isporuke	mm	6500

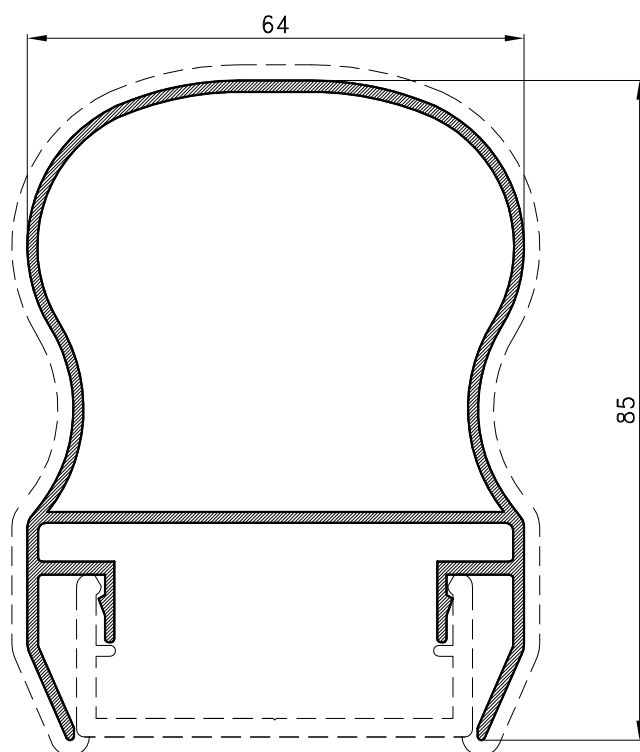

Profil		
Art.-Br.	<b>F-1334</b>	
Težina	kg/m	<b>1.185</b>
Opseg	mm	414.53
Moment inercije	$I_x$ (cm <sup>4</sup> )	28.66
	$I_y$ (cm <sup>4</sup> )	26.24
	$W_x$ (cm <sup>4</sup> )	6.70
	$W_y$ (cm <sup>4</sup> )	8.20
Dužina isporuke	mm	6500

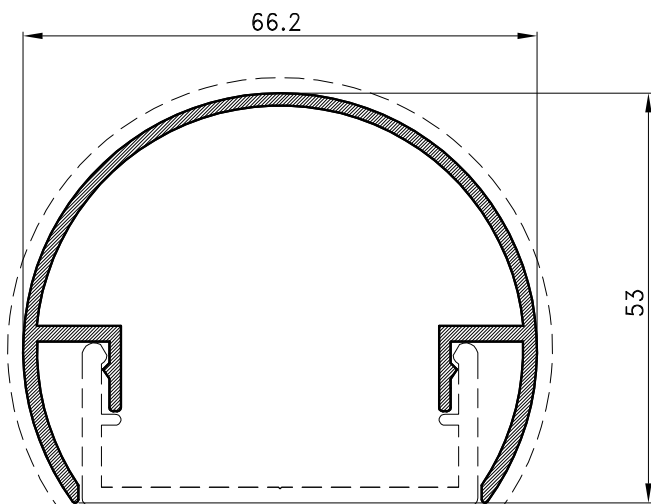

Profil		
Art.-Br.	<b>F-0621</b>	
Težina	kg/m	<b>0.831</b>
Opseg	mm	367
Moment inercije	$I_x$ (cm <sup>4</sup> )	7.21
	$I_y$ (cm <sup>4</sup> )	19.42
	$W_x$ (cm <sup>4</sup> )	2.55
	$W_y$ (cm <sup>4</sup> )	5.87
Dužina isporuke	mm	6500

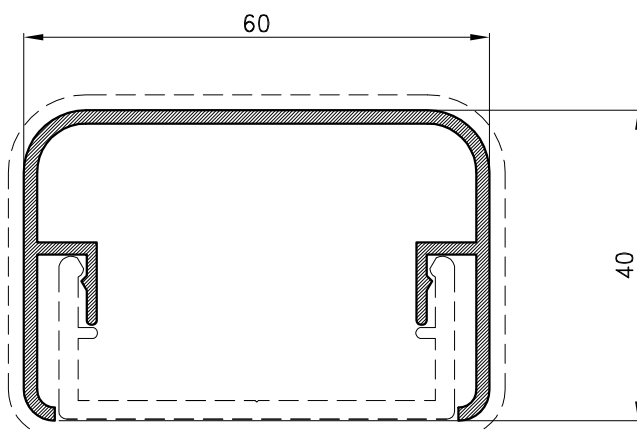

Profil		
Art.-Br.	<b>F-0689</b>	
Težina	kg/m	<b>0.74</b>
Opseg	mm	335
Moment inercije	$I_x$ (cm <sup>4</sup> )	4.20
	$I_y$ (cm <sup>4</sup> )	15.94
	$W_x$ (cm <sup>4</sup> )	1.64
	$W_y$ (cm <sup>4</sup> )	5.31
Dužina isporuke	mm	6500

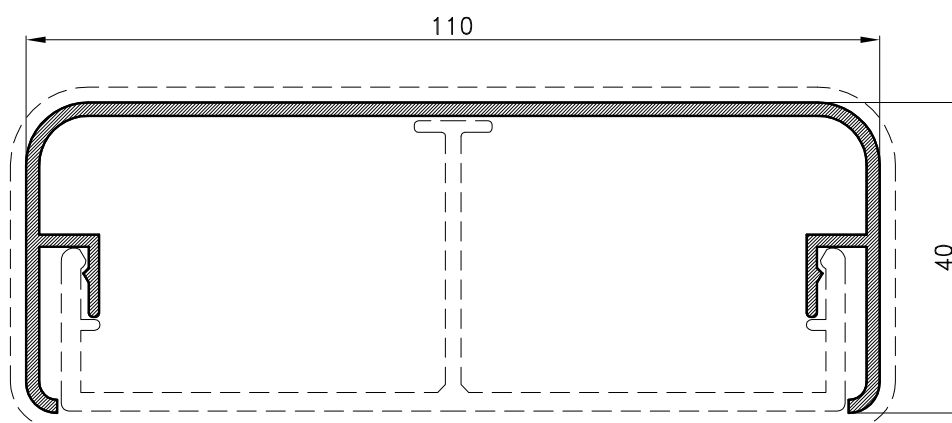

Profil		
Art.-Br.	<b>F-1096</b>	
Težina	kg/m	<b>0.970</b>
Opseg	mm	435
Moment inercije	$I_x$ (cm <sup>4</sup> )	5.37
	$I_y$ (cm <sup>4</sup> )	65.89
	$W_x$ (cm <sup>4</sup> )	1.86
	$W_y$ (cm <sup>4</sup> )	11.98
Dužina isporuke	mm	6500

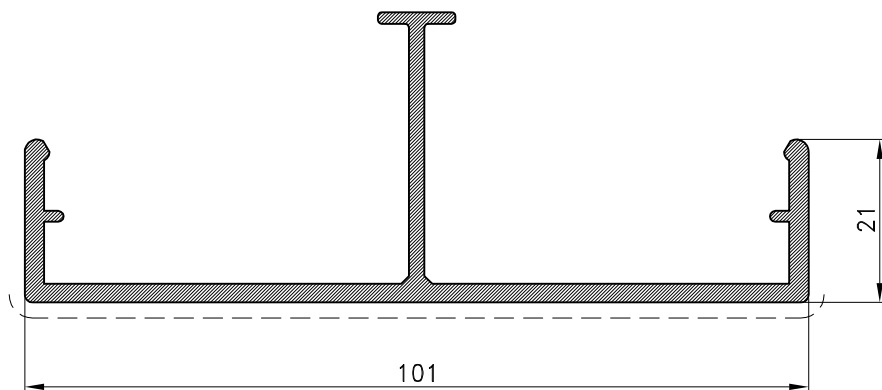

Profil		
Art.-Br.	<b>F-1097</b>	
Težina	kg/m	<b>1.148</b>
Opseg	mm	372
Moment inercije	$I_x$ (cm <sup>4</sup> )	4.21
	$I_y$ (cm <sup>4</sup> )	44.62
	$W_x$ (cm <sup>4</sup> )	1.42
	$W_y$ (cm <sup>4</sup> )	8.83
Dužina isporuke	mm	6500

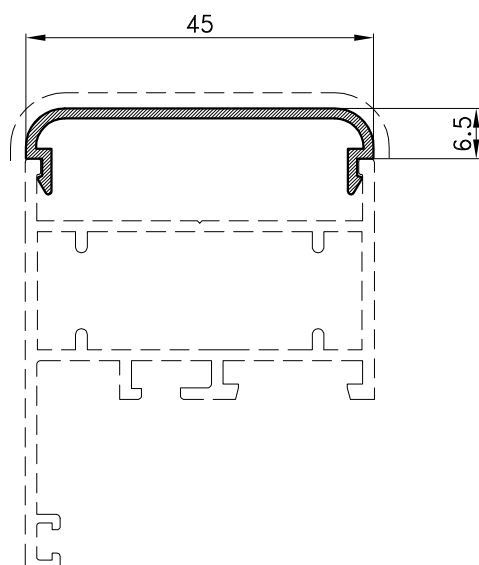

Profil		
Art.-Br.	<b>M45-756</b>	
Težina	kg/m	<b>0.225</b>
Opseg	mm	132
Moment inercije	$I_x$ (cm <sup>4</sup> )	0.08
	$I_y$ (cm <sup>4</sup> )	2.02
	$W_x$ (cm <sup>4</sup> )	0.09
	$W_y$ (cm <sup>4</sup> )	0.90
Dužina isporuke	mm	6500

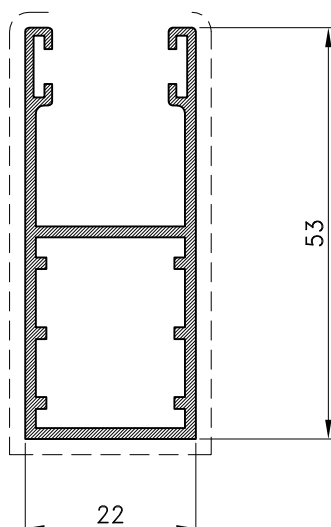

Profil		
Art.-Br.	<b>F-0608</b>	
Težina	kg/m	<b>0.607</b>
Opseg	mm	231
Moment inercije	$I_x$ (cm <sup>4</sup> )	5.86
	$I_y$ (cm <sup>4</sup> )	1.90
	$W_x$ (cm <sup>4</sup> )	2.00
	$W_y$ (cm <sup>4</sup> )	1.72
Dužina isporuke	mm	6500

# Vezni elementi

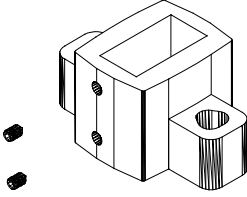
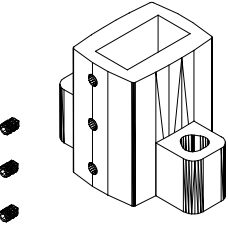
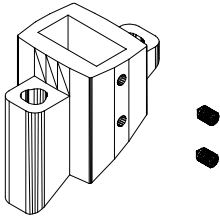
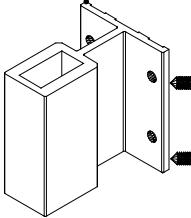
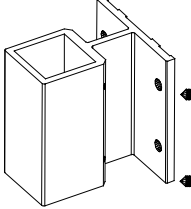
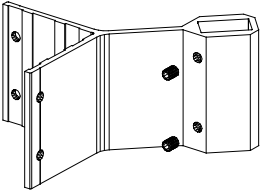

Oznaka	Izgled-presjek	Opis	Materijal	Nap.
521.042		- Stopa ograde; - Stara oznaka: OG-S-01	Al.	
521.043		- Stopa ograde; - Stara oznaka: OG-S-02	Al.	
521.044		- Stopa ograde pod kutem; - Stara oznaka: OG-S-03	Al.	
521.054		- Bočna stopa ograde ; - Stara oznaka: OG-V-07	Al.	
521.126		- Bočna stopa ograde; 2 vijka M6X10 DIN 914	Al.	
521.062		- Bočna stopa ograde ;	Al.	

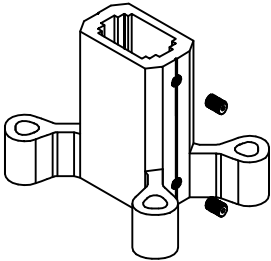
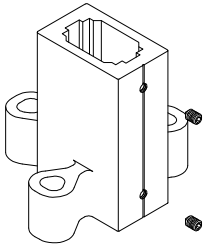
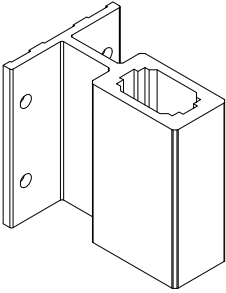
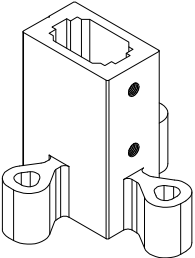
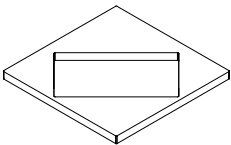
Oznaka	Izgled-presjek	Opis	Materijal	Nap.
521.060		- Stopa ograde;	Al.	
521.266		- Stopa ograde;	Al.	
521.523.01 .02 .03		- Stopa ograde - Radi se iz profila F-1856 - H=100mm	Al	
521.522.01 .02 .03		- Stopa ograde - Radi se iz profila F-1582 - H=100mm	Al	
521.125		- Pločica 52x52x3 za bočnu stopu 521.062	Al.	

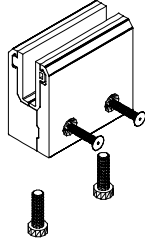
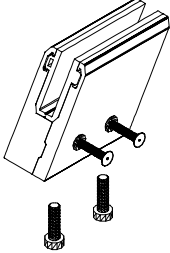
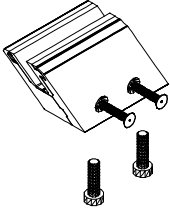
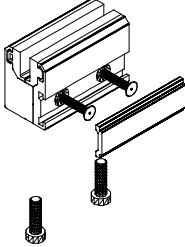
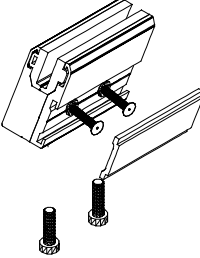
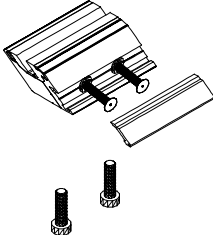
Oznaka	Izgled-presjek	Opis	Materijal	Nap.
521.082		- Držać stakla (staklo 55.2 - ravni)	Al	
521.093		- Držać stakla (staklo 55.2 - kosi D)	Al	
521.096		- Držać stakla (staklo 55.2 - kosi L)	Al	
521.045		- Držać stakla (staklo 44.2 - ravni) -Stara oznaka - DSR-01	Al	
521.046		- Držać stakla (staklo 44.2 - kosi D) -Stara oznaka - DSK-02	Al	
521.131		- Držać stakla (staklo 44.2 - kosi L)	Al	

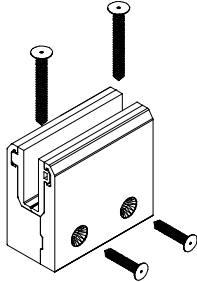
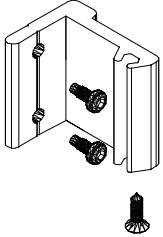
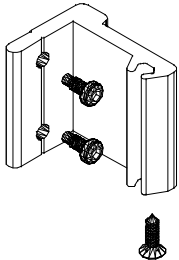
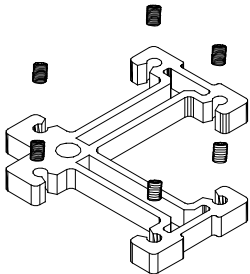
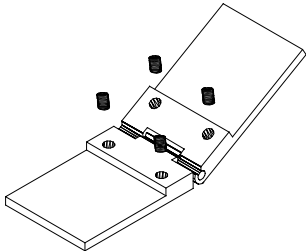
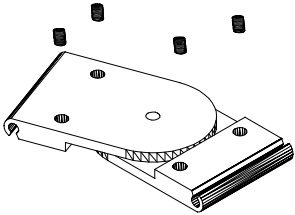
Oznaka	Izgled-presjek	Opis	Materijal	Nap.
521.099		-Bočni držač stakla (staklo 55.2 )	Al	
521.047		- Veznik za F-0174 ; - Stara oznaka : 060 814	Al	
521.048		- Veznik za F-0048 ; - Stara oznaka : 060 814/A	Al.	
521.049		- Veznik; - Stara oznaka: OG-V-01	Al.	
521.050		- Veznik pod kutem; - Stara oznaka: OG-V-02	Al	
521.051		- Veznik pod kutem; - Stara oznaka: OG-V-03	Al	

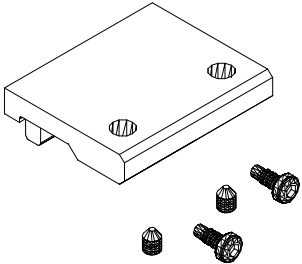
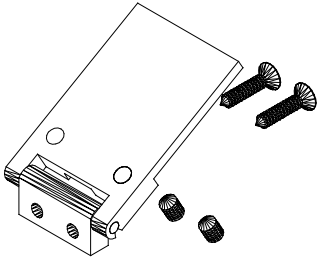
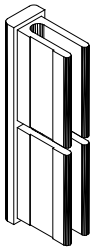
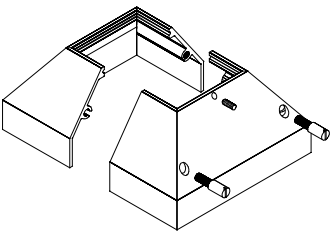
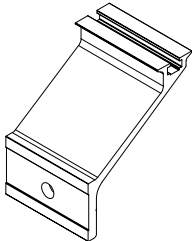
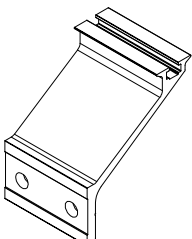
Oznaka	Izgled-presjek	Opis	Materijal	Nap.
521.052		<ul style="list-style-type: none"> <li>- Veznik pod 90°</li> <li>- Stara oznaka: OG-V-04</li> </ul>	Al	
521.053		<ul style="list-style-type: none"> <li>- Veznik pod kutem;</li> <li>- Stara oznaka: OG-V-05</li> </ul>	Al	
391.045		<ul style="list-style-type: none"> <li>- Bočni poklopac za profil F-0062</li> <li>- Stara oznaka: DE-0340</li> </ul>	Al	
392.001.01 .02 .03		<ul style="list-style-type: none"> <li>- Maska stubića al. ograde</li> <li>- Oznaka proizvođača 700.300.310 700.300.305 ; 700.300.313</li> <li>- Boje: 01- bijela; 02 - siva; 03 - crna</li> </ul>	Al.	
521.512.01 .02 .03		<ul style="list-style-type: none"> <li>- držač profila podrukohvata</li> <li>- radi se iz profila F-1827</li> <li>- koristi se vijak-tipla</li> </ul>	Al.	
521.513.01 .02 .03		<ul style="list-style-type: none"> <li>- držač profila podrukohvata</li> <li>- radi se iz profila F-1827</li> <li>- koristi se vijak-tipla</li> </ul>	Al.	



# PVC komponente

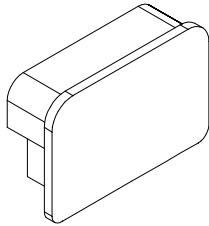
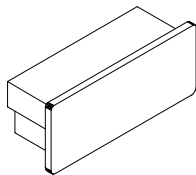
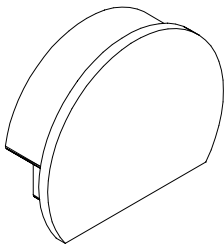
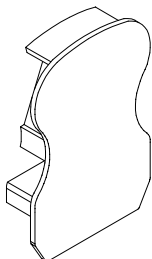
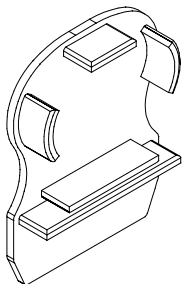

Oznaka	Izgled-presjek	Opis	Materijal	Nap.
<b>373.007.01</b> 02 03		- Bočni čep za profil F-0689 - Stara oznaka: RA 450 01-bijela 02-siva 03-crna	PVC	
<b>373.008.01</b> 02 03		- Bočni čep za profil F-0620 - Stara oznaka: RA 452 01-bijela 02-siva 03-crna	PVC	
<b>374.036.01</b> 02 03		- Bočni čep za profil F-0621 - Stara oznaka: RA 723 01-bijela 02-siva 03-crna	PVC	
<b>373.009.01</b> 02 03		- Stara oznaka: RA 752 - Bočni čep za profil F-0673 01-bijela 02-siva 03-crna	PVC	
<b>373.030.01</b> 02 03		- Bočni čep za profil F-1334 01-bijela 02-siva 03-crna	PVC	



# Presjeci



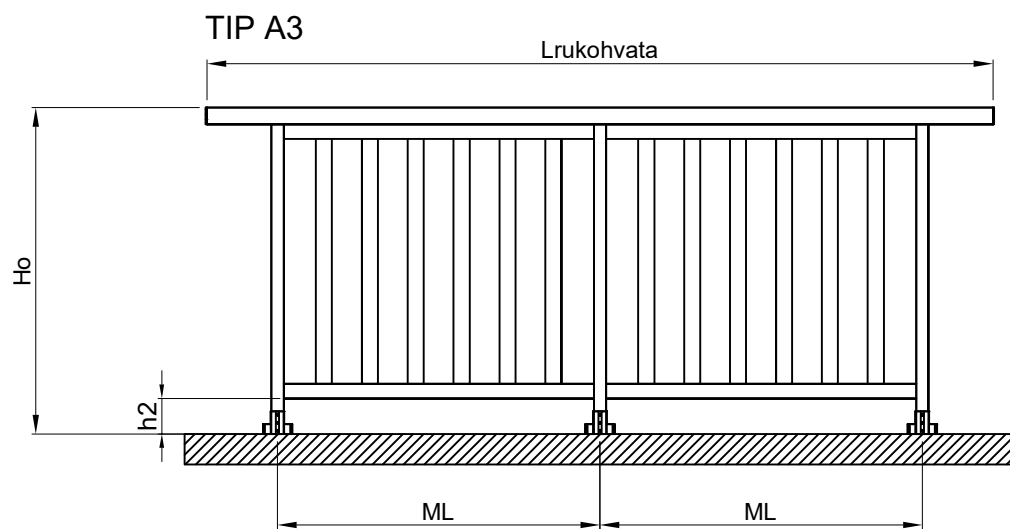
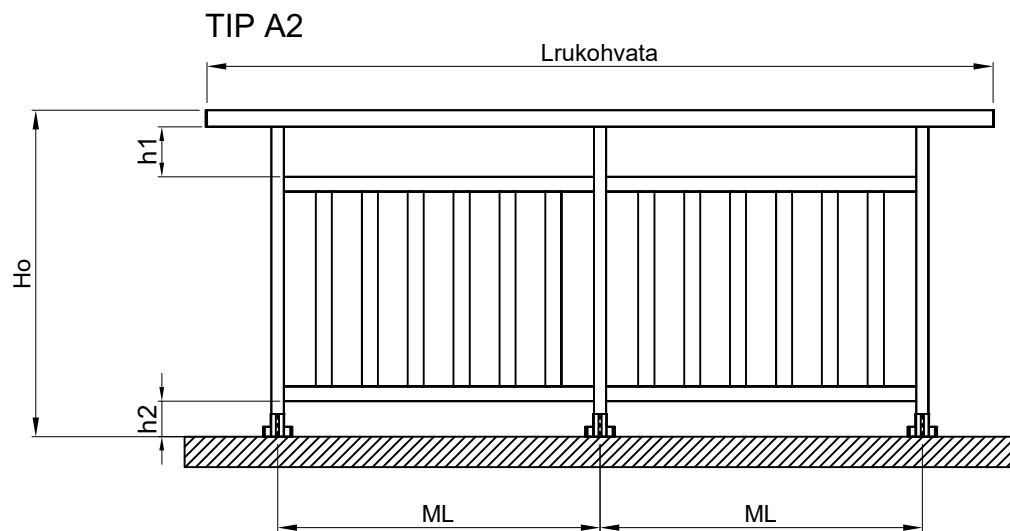
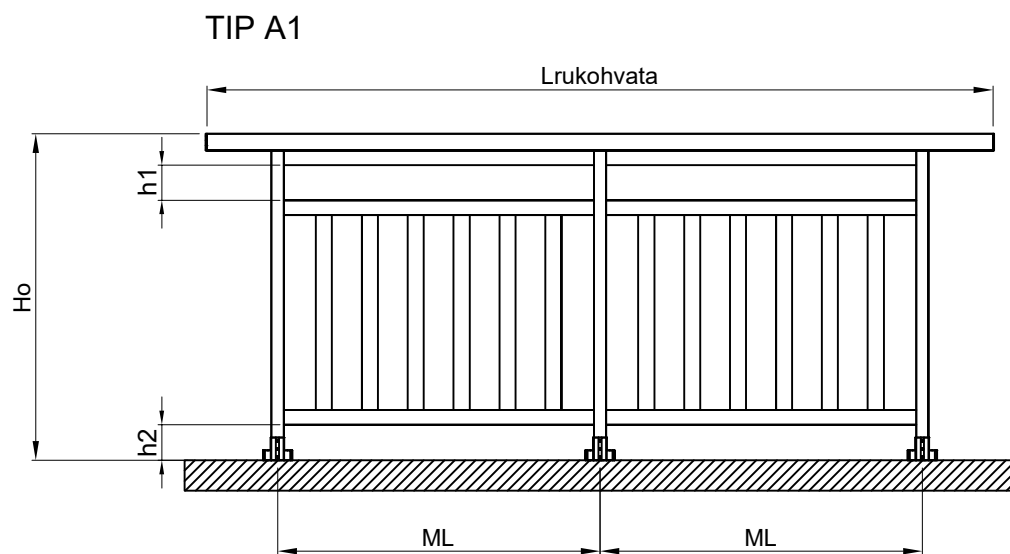



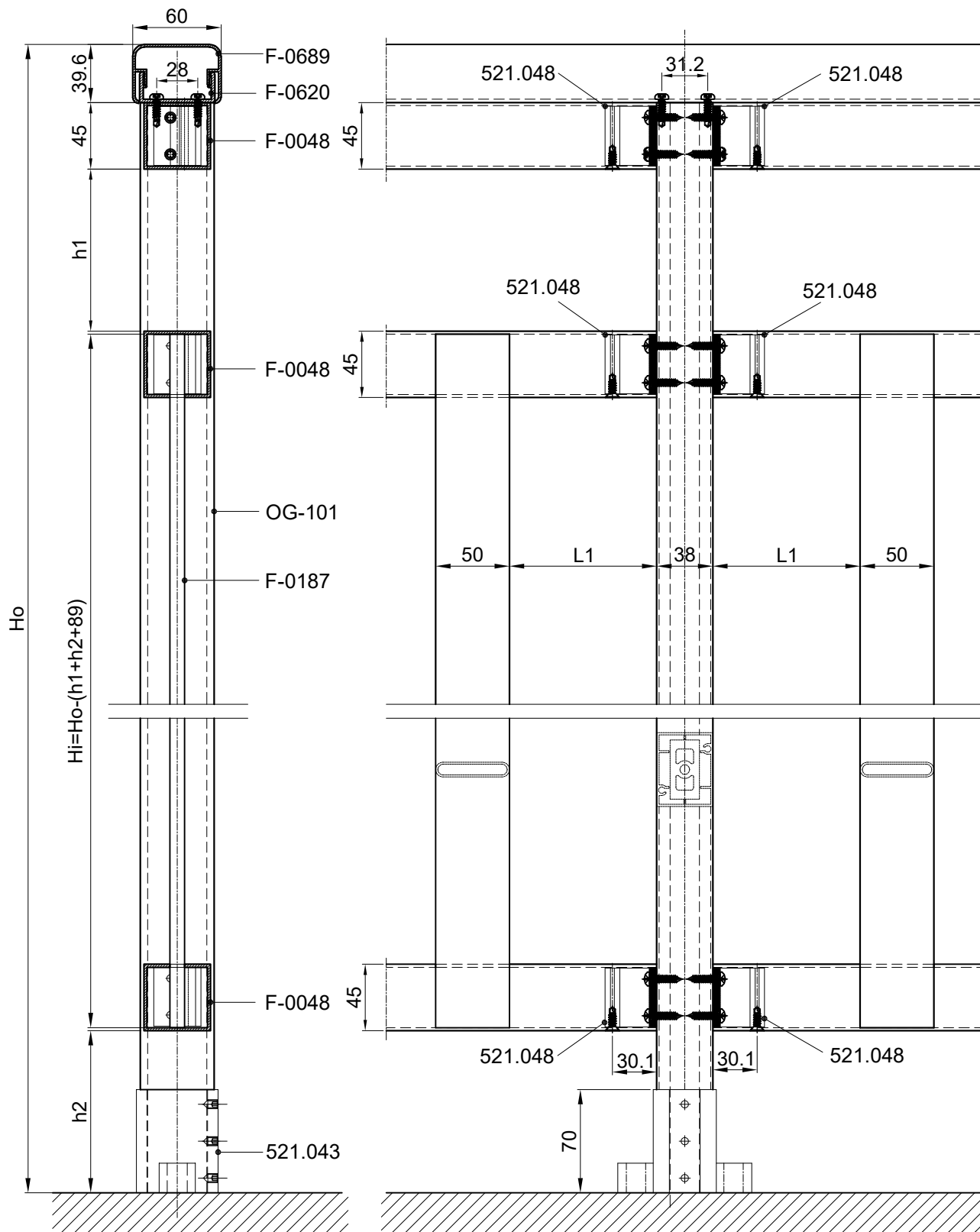
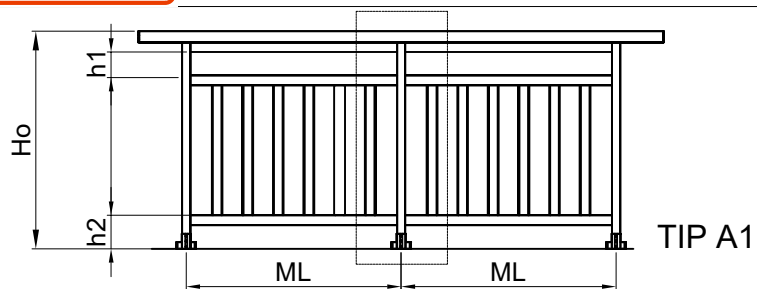

M 1:4

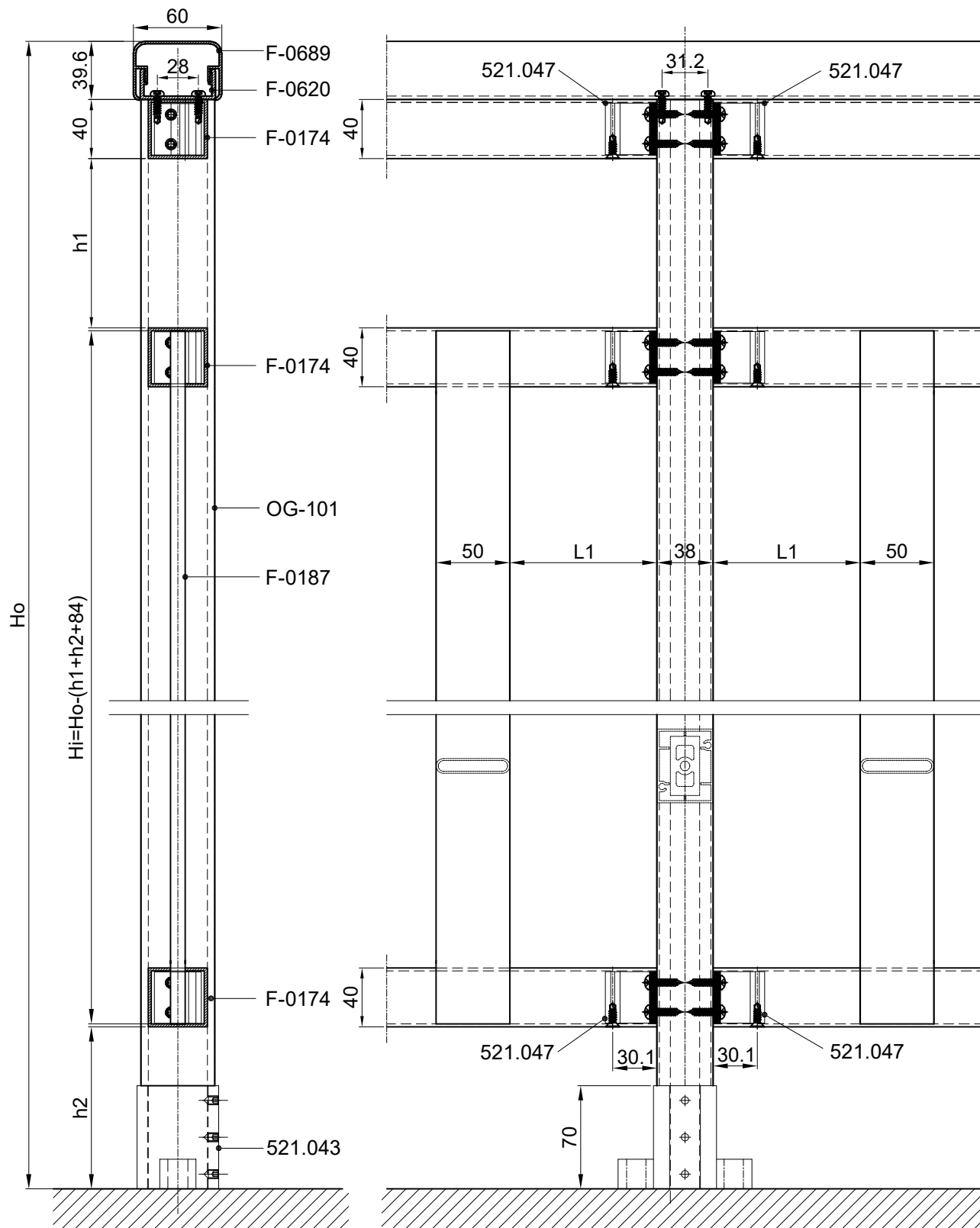
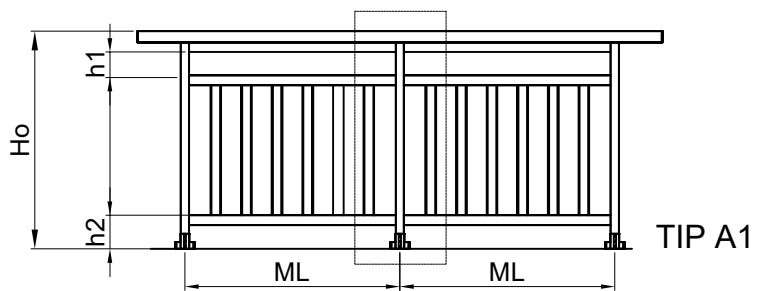

M 1:4

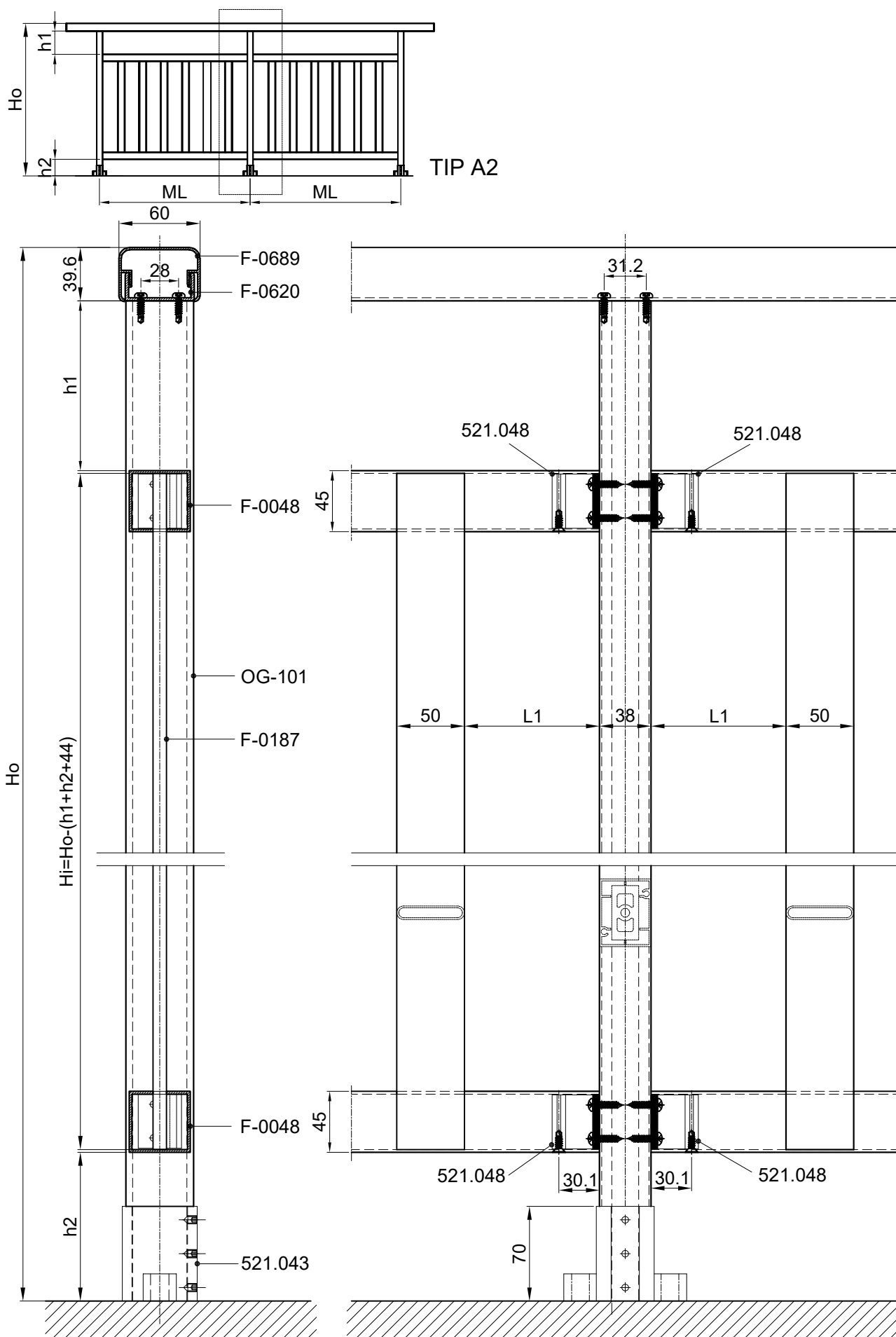

M 1:4

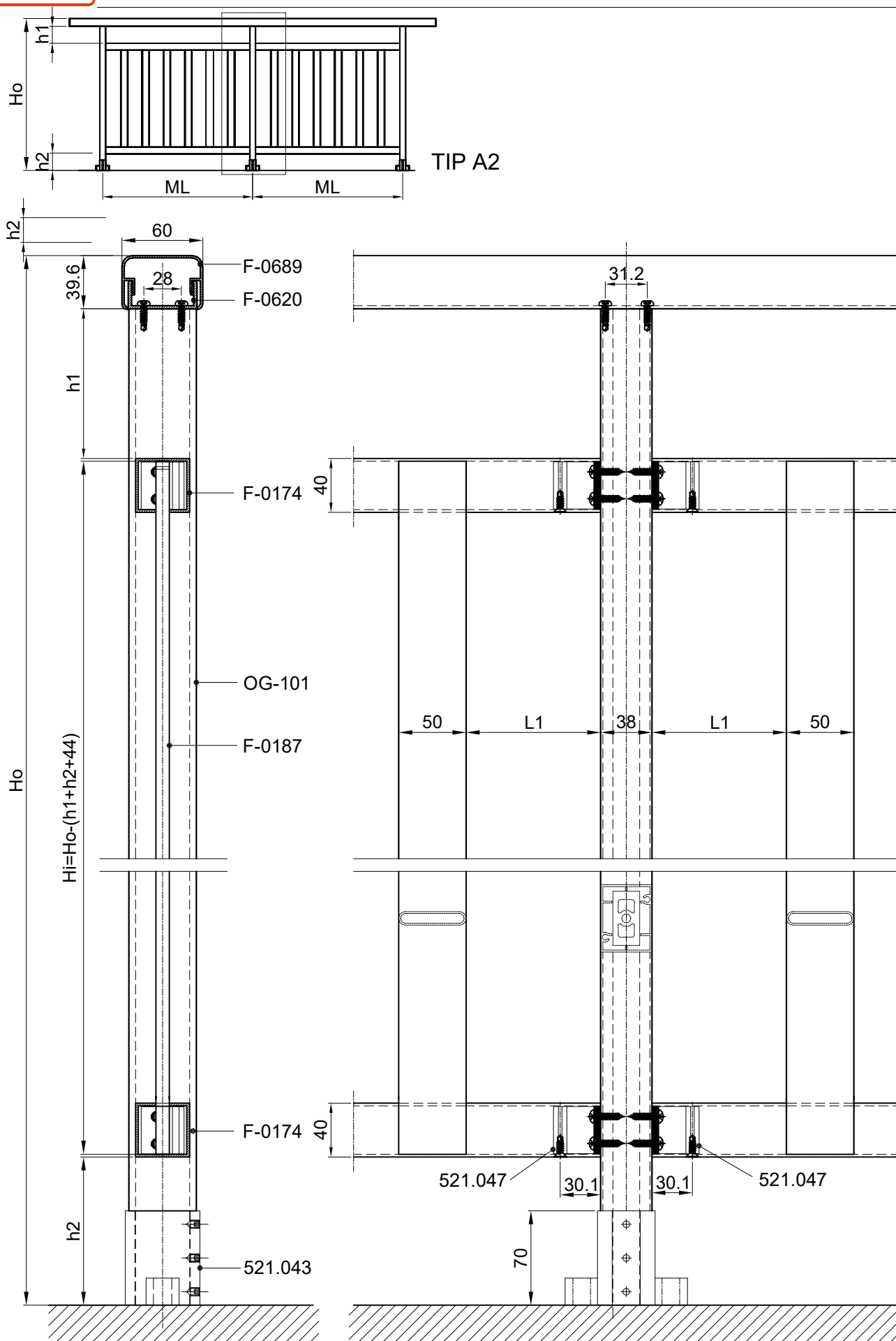

M 1:4

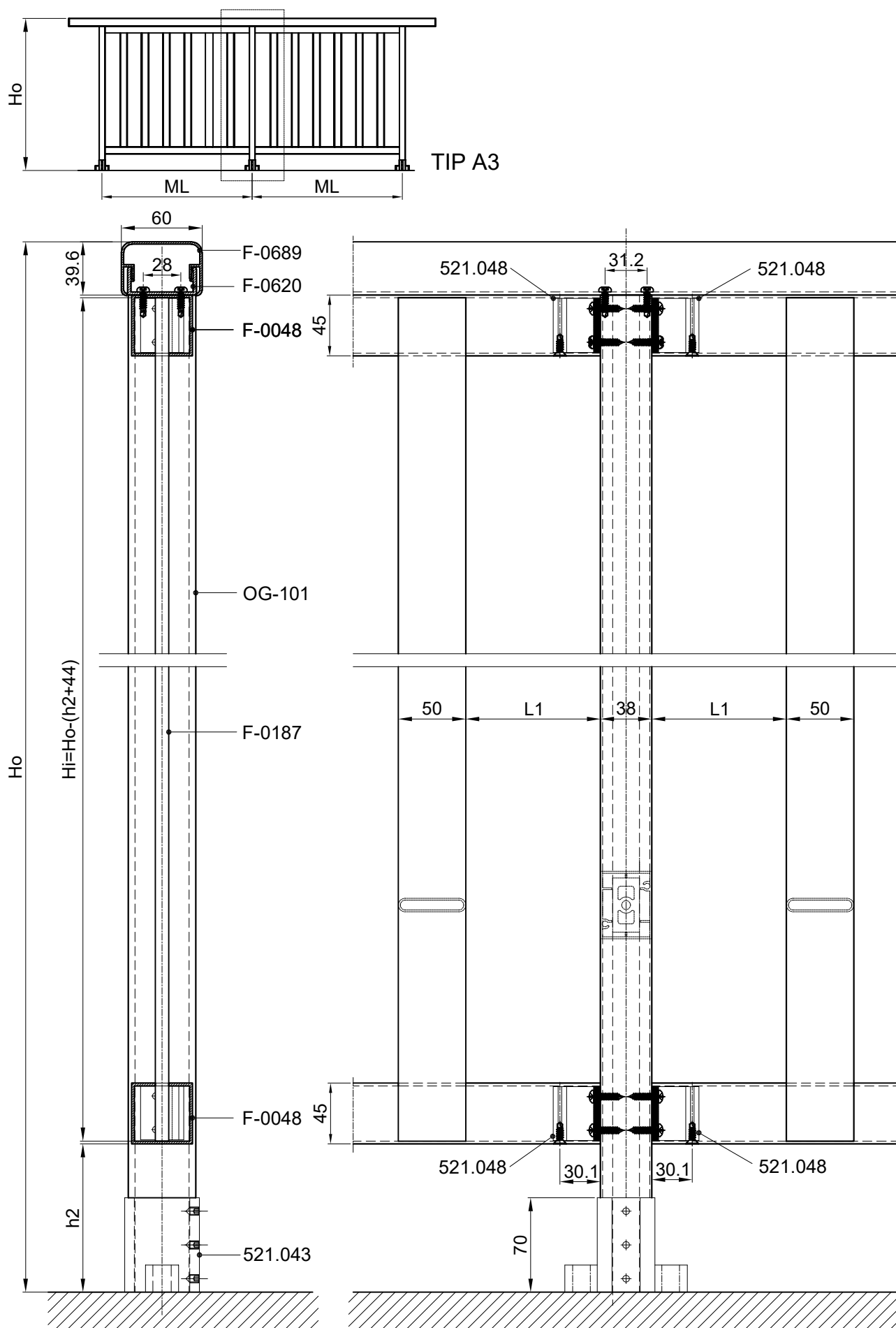

M 1:4

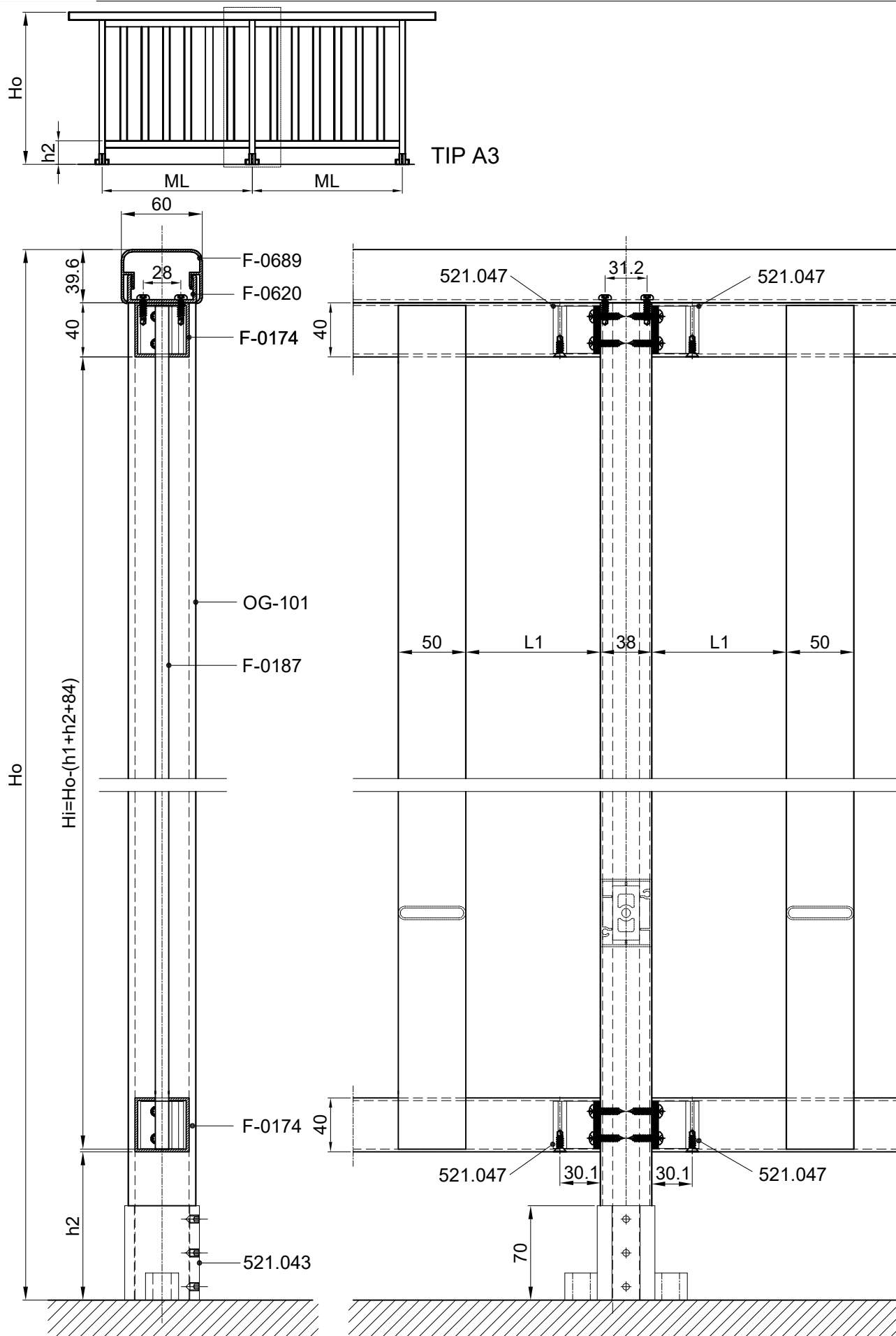

M 1:4

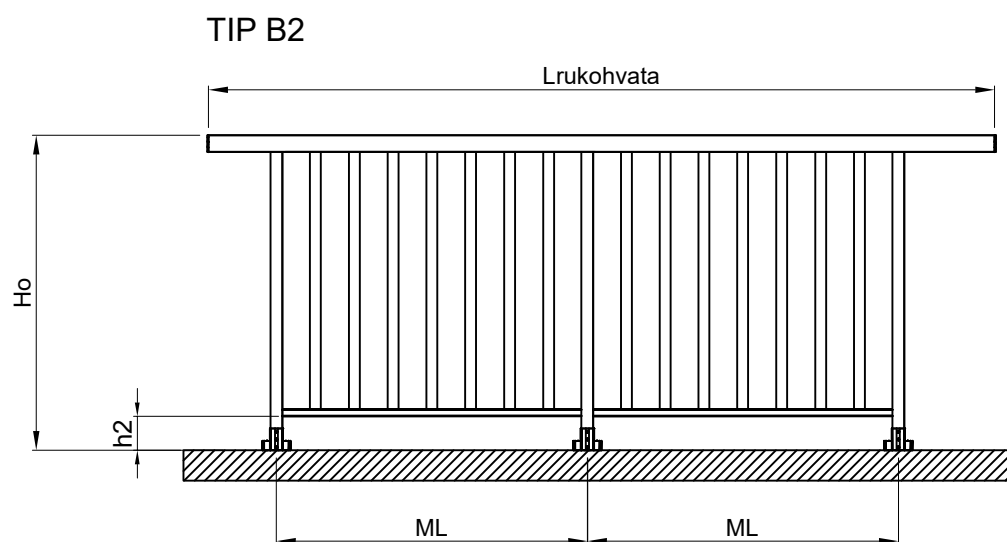
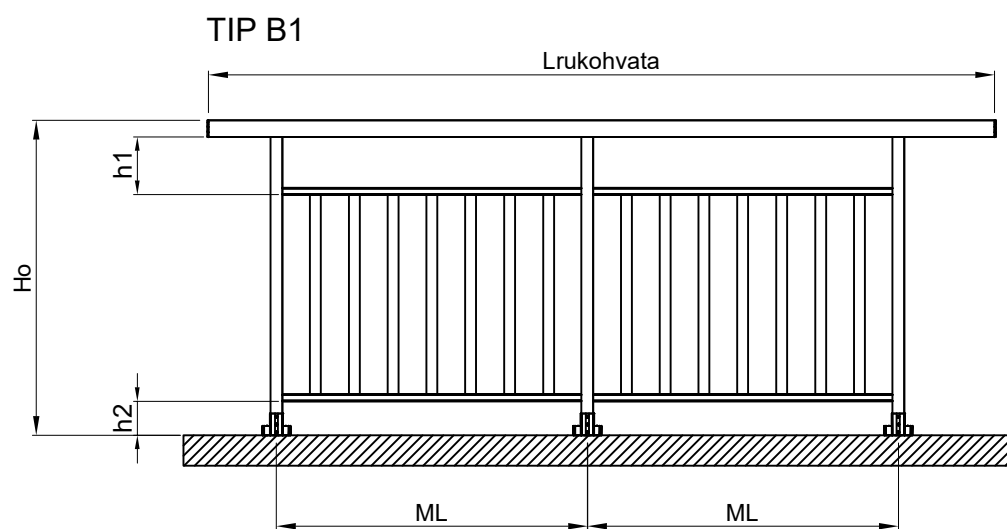



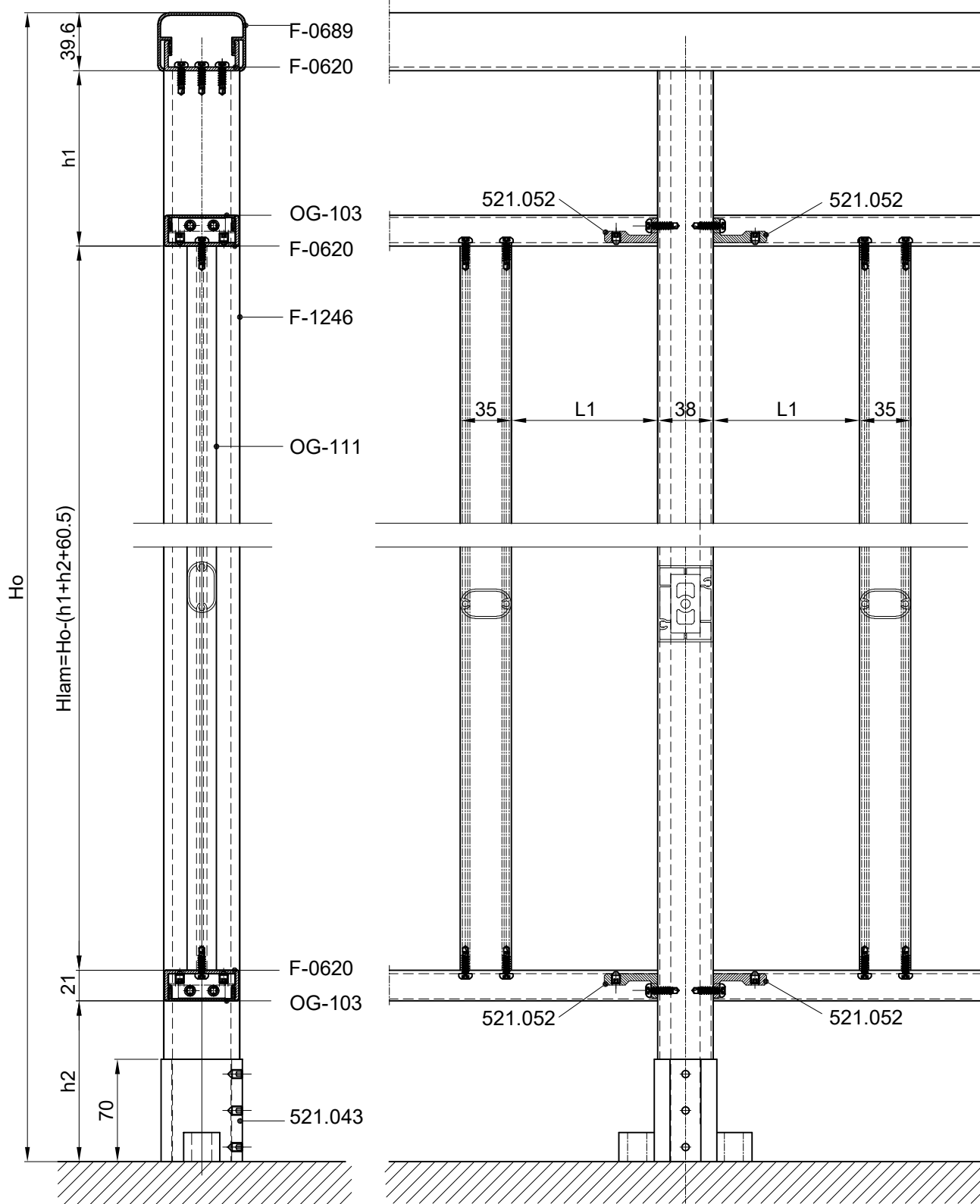
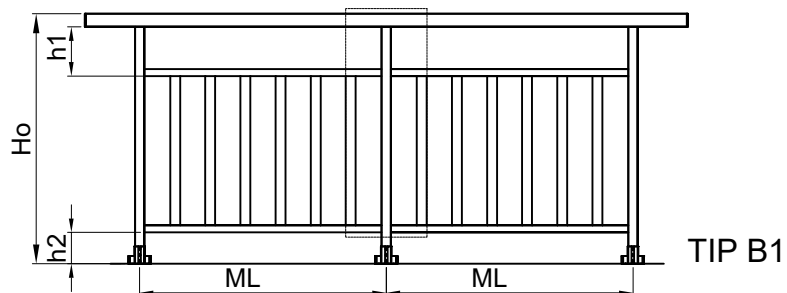

M 1:4

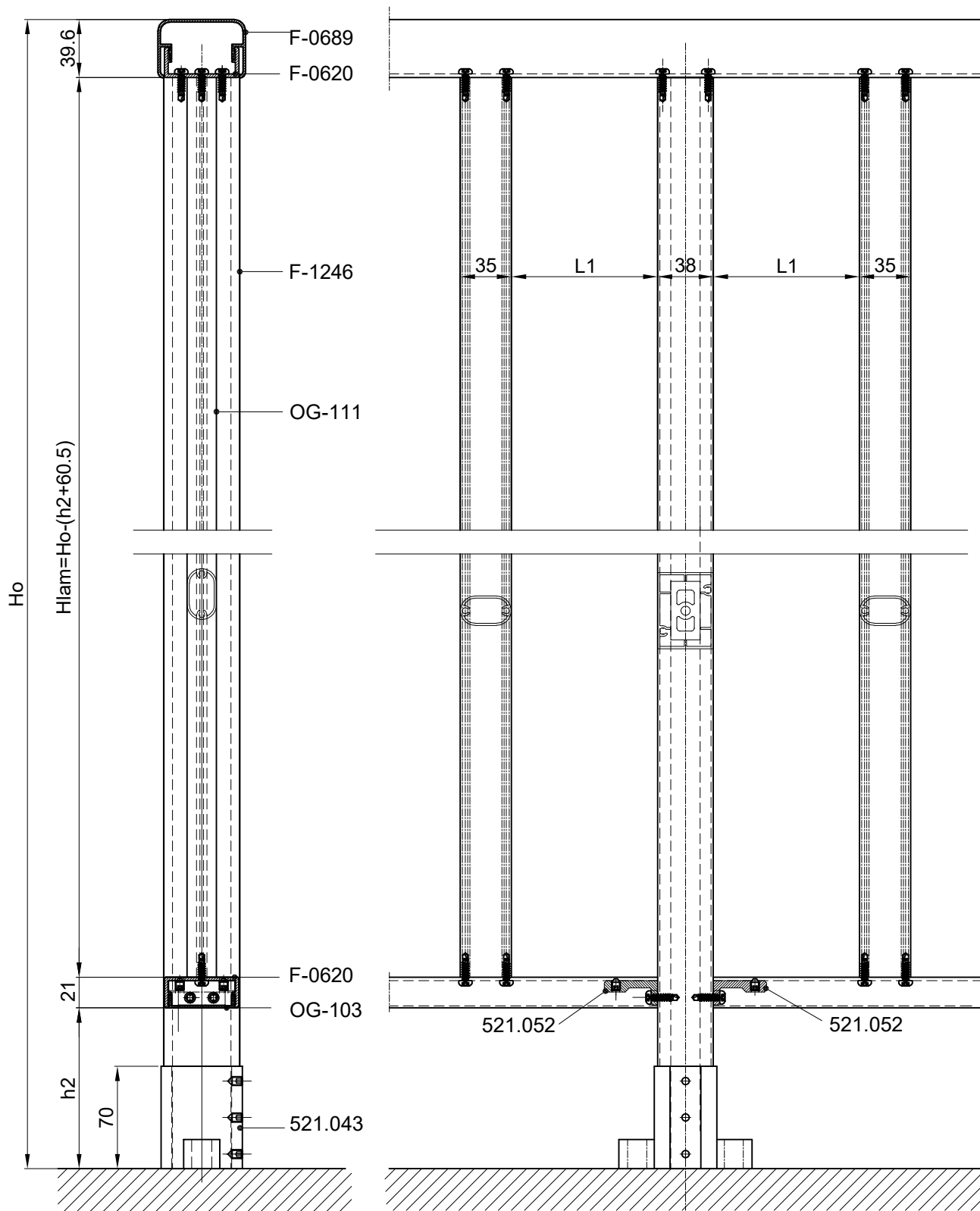
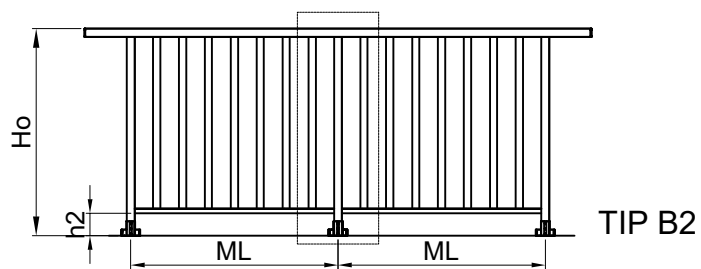

M 1:4

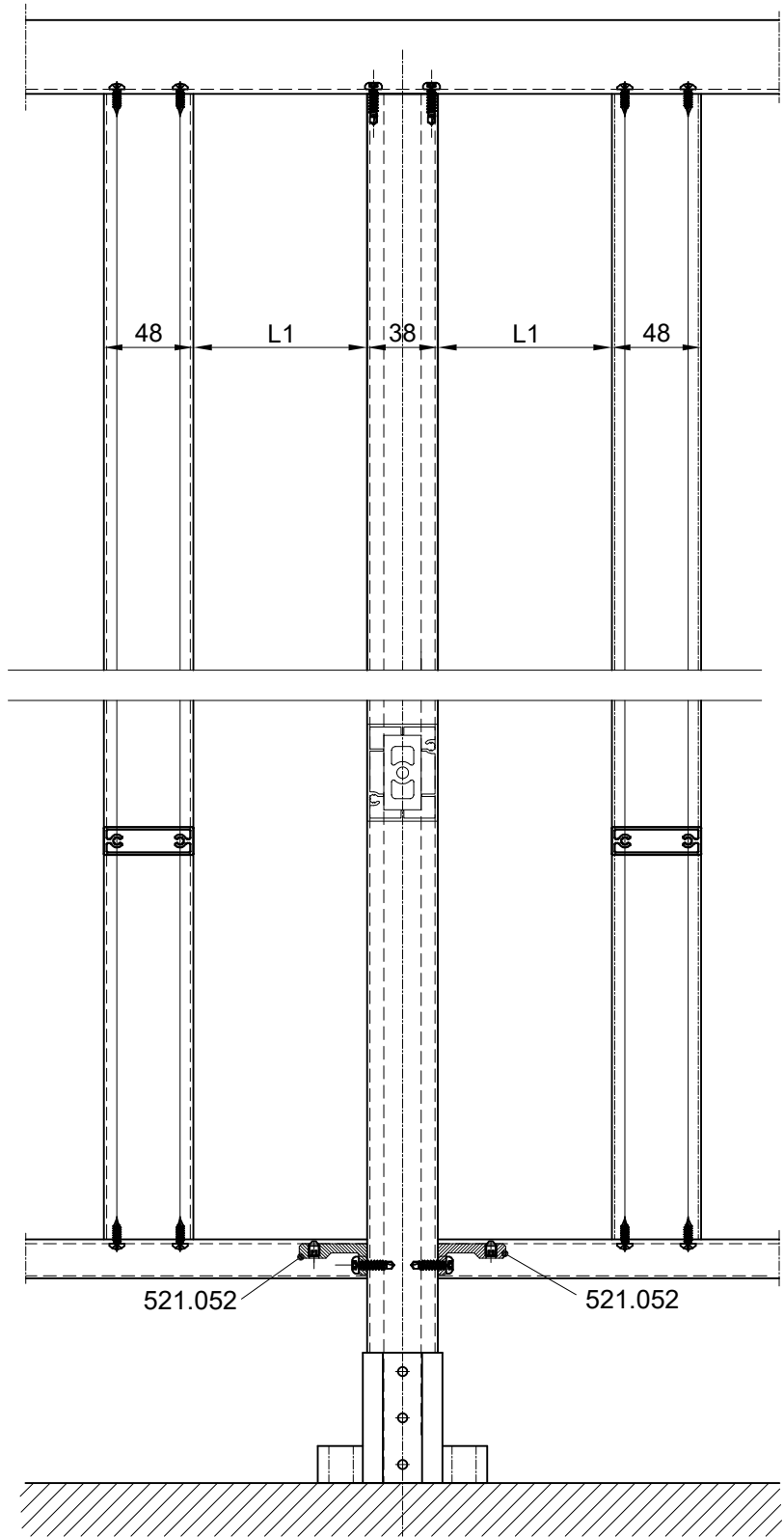
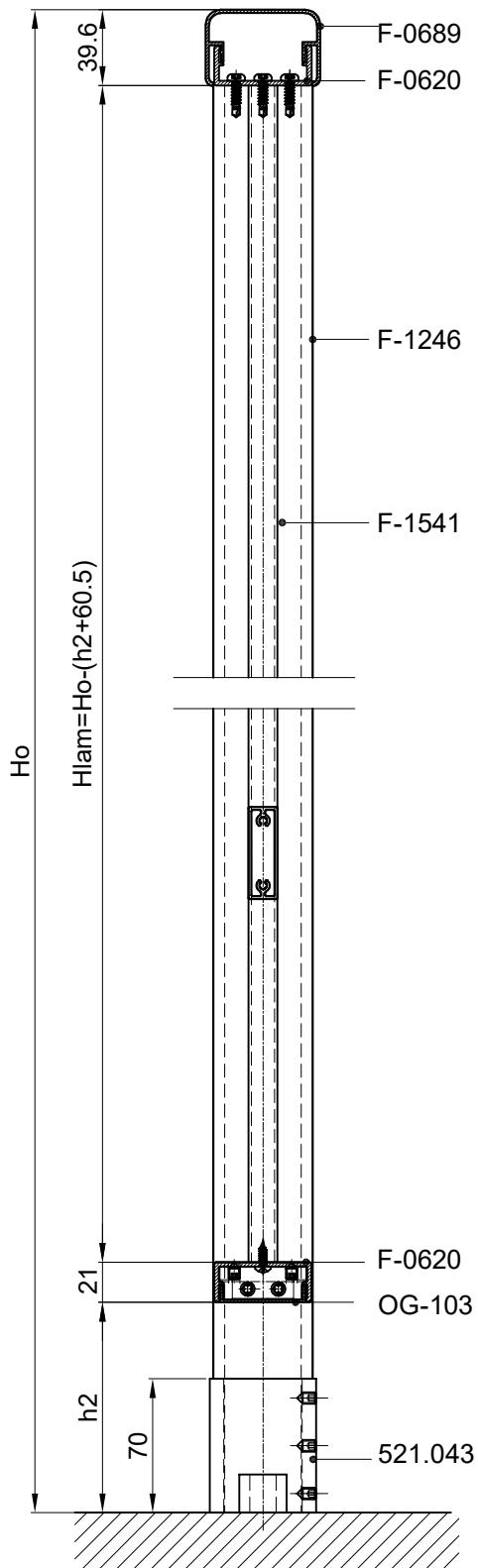
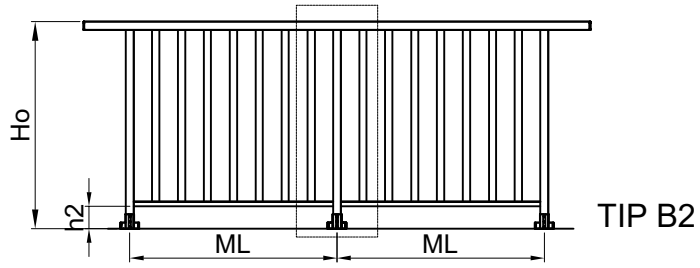

M 1:4

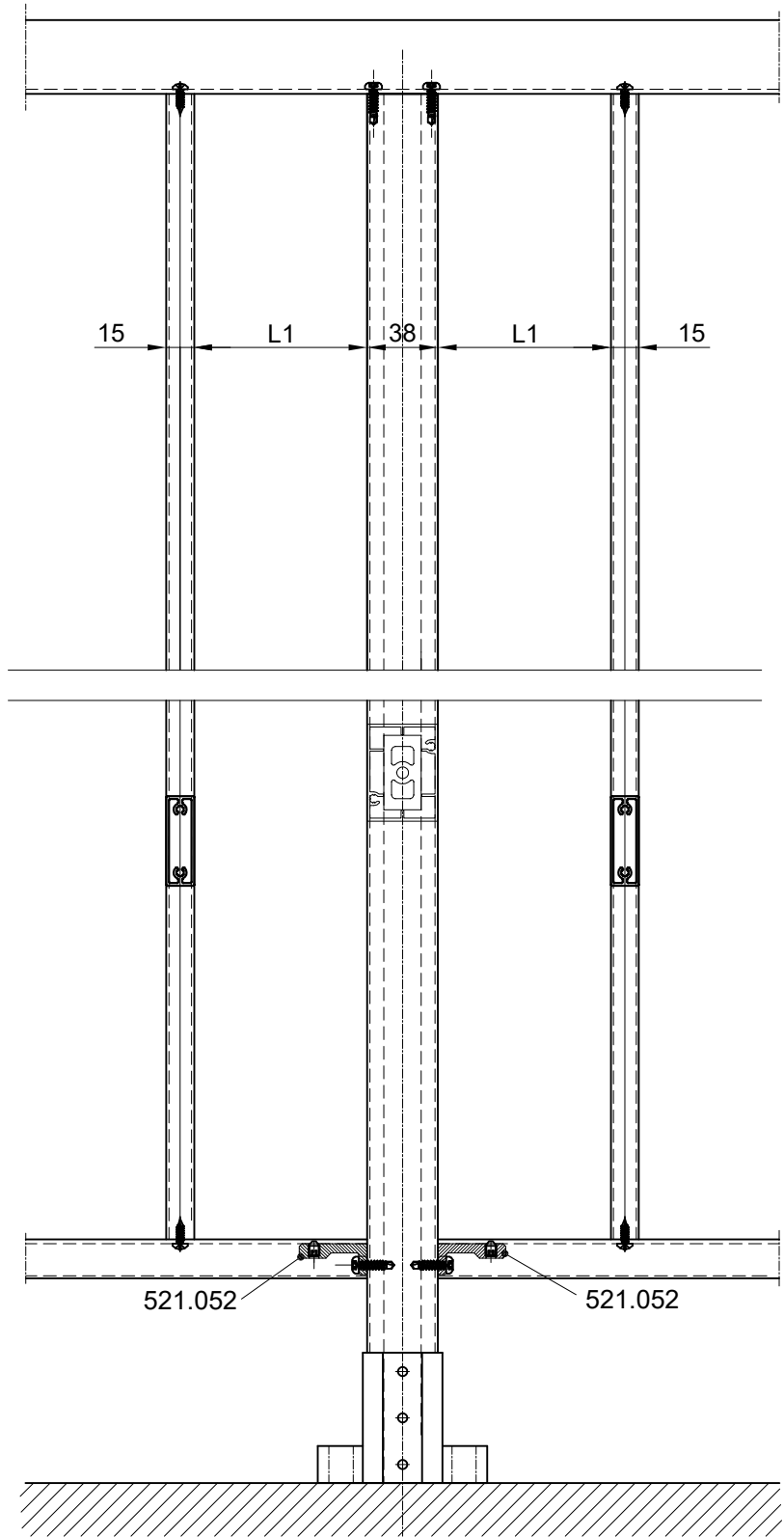
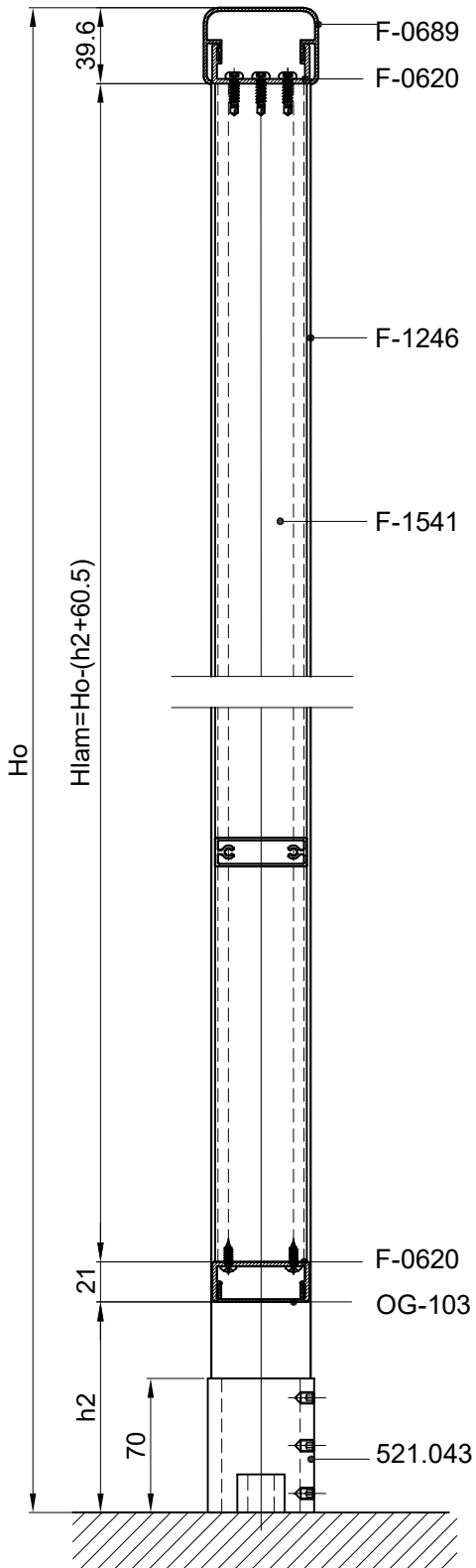
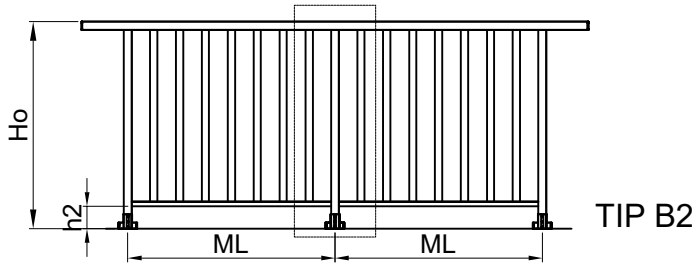

M 1:4

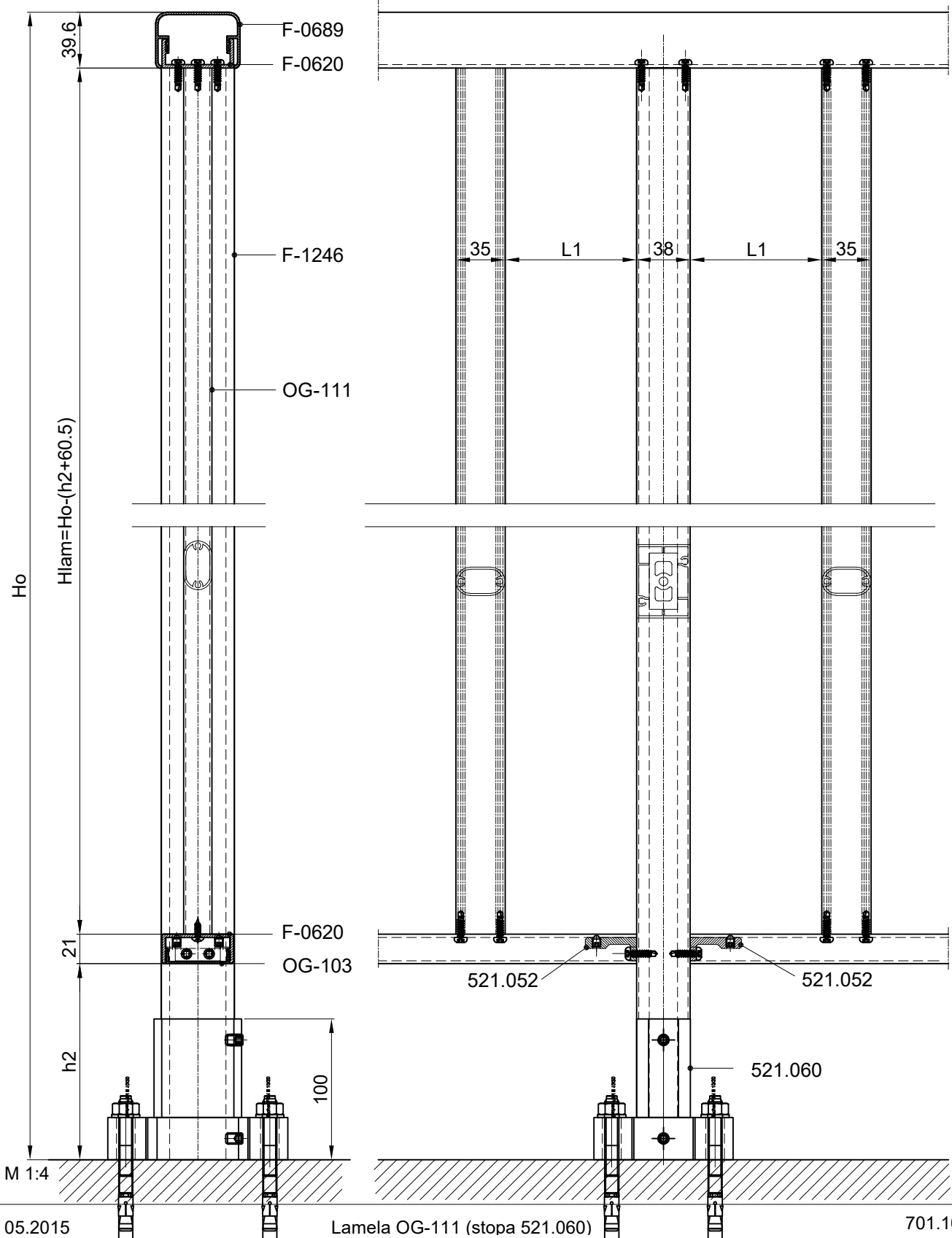
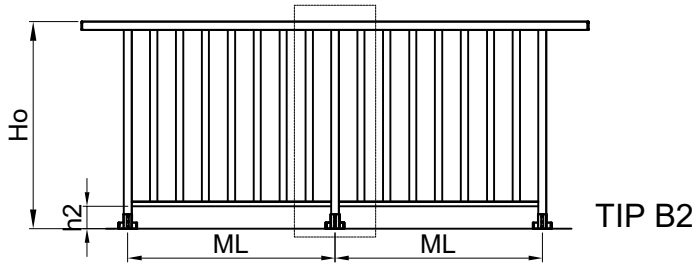

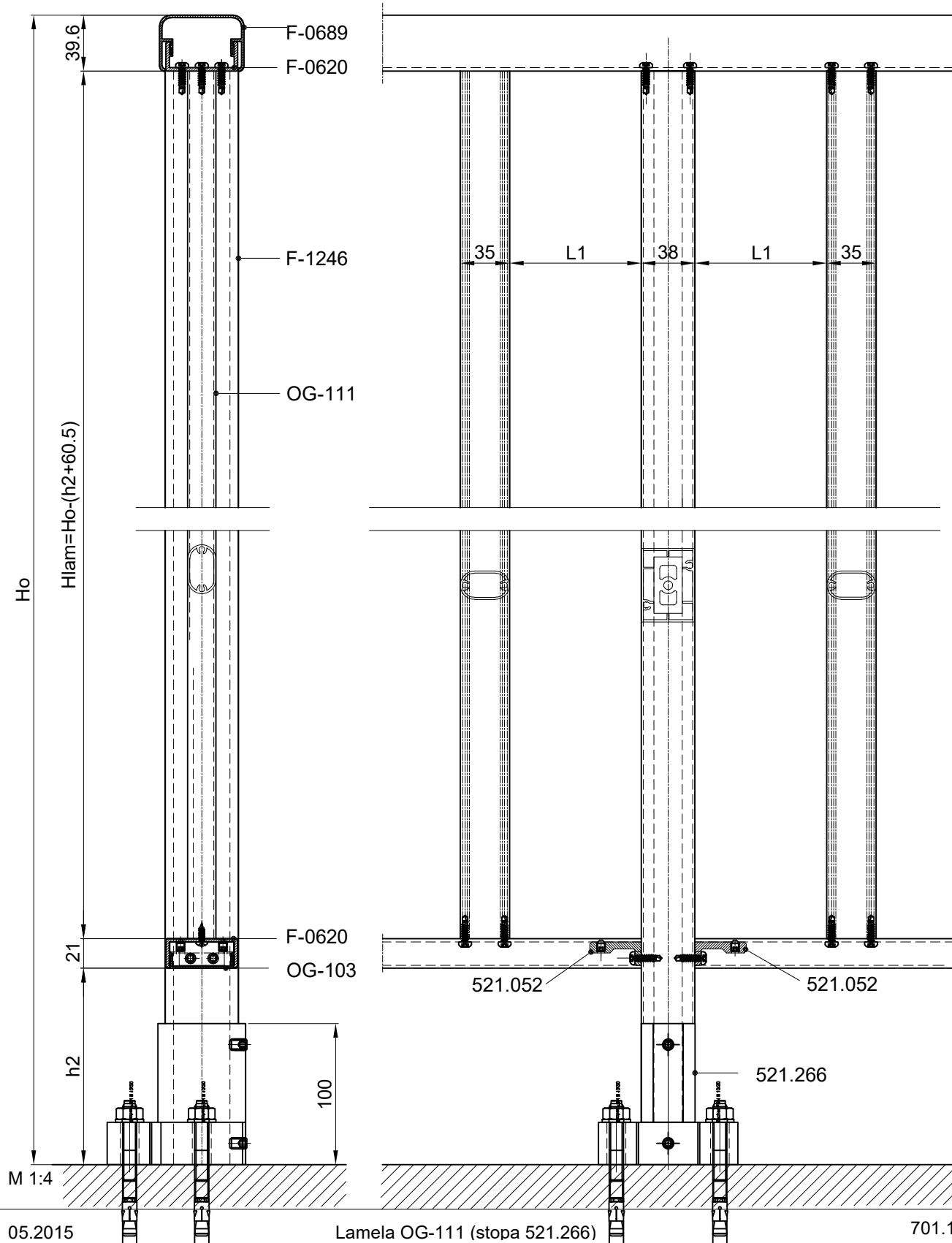
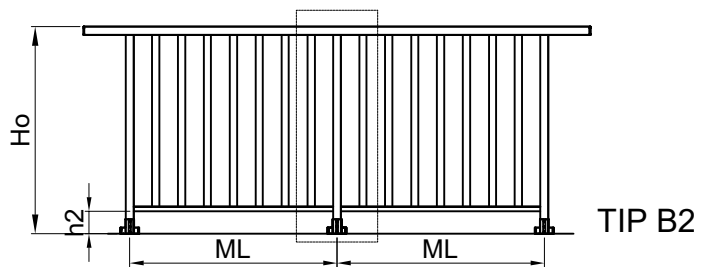

Držač stakla 521.082 /za staklo 55.2

TIP C1

Kopča 521.082  
/staklo 55.2/

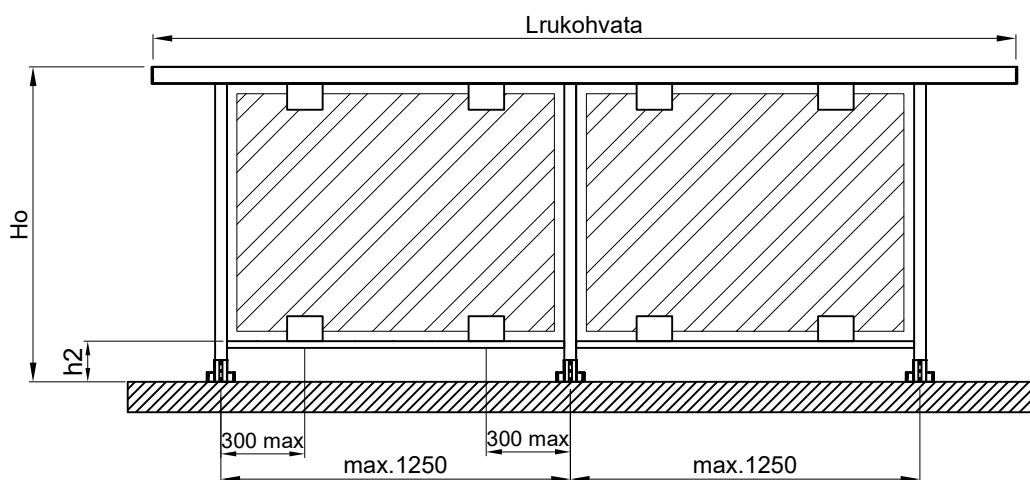

TIP C2

Kopča 521.082  
/staklo 55.2/

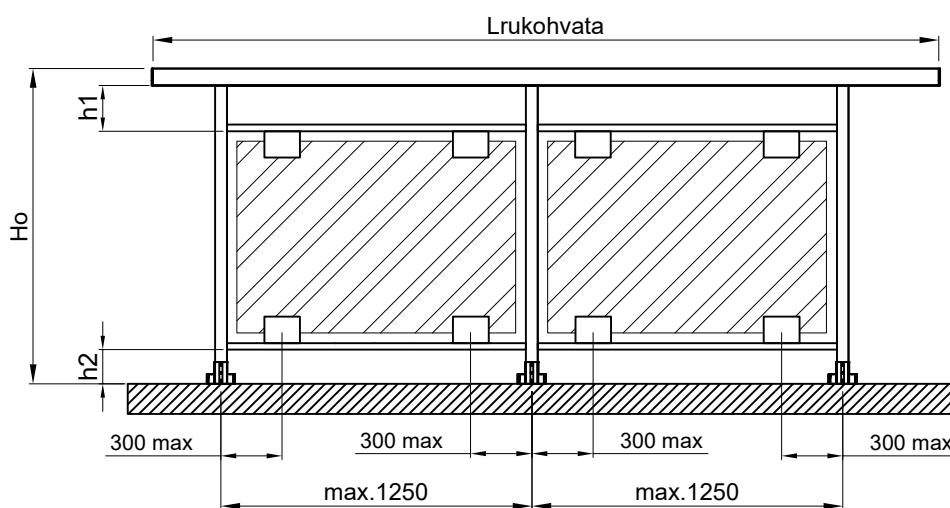

TIP C3

Kopča 521.099  
/staklo 55.2/

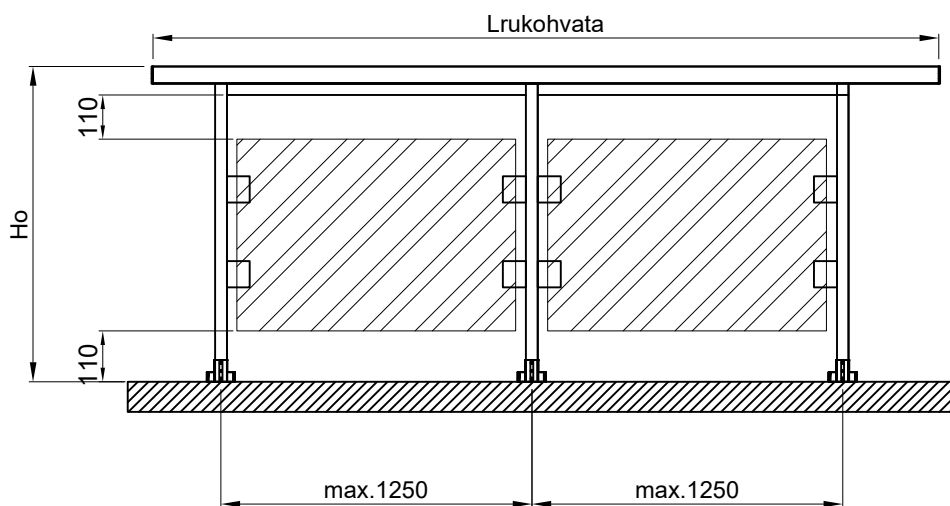

Držač stakla 521.082 /za staklo 55.2

TIP C4

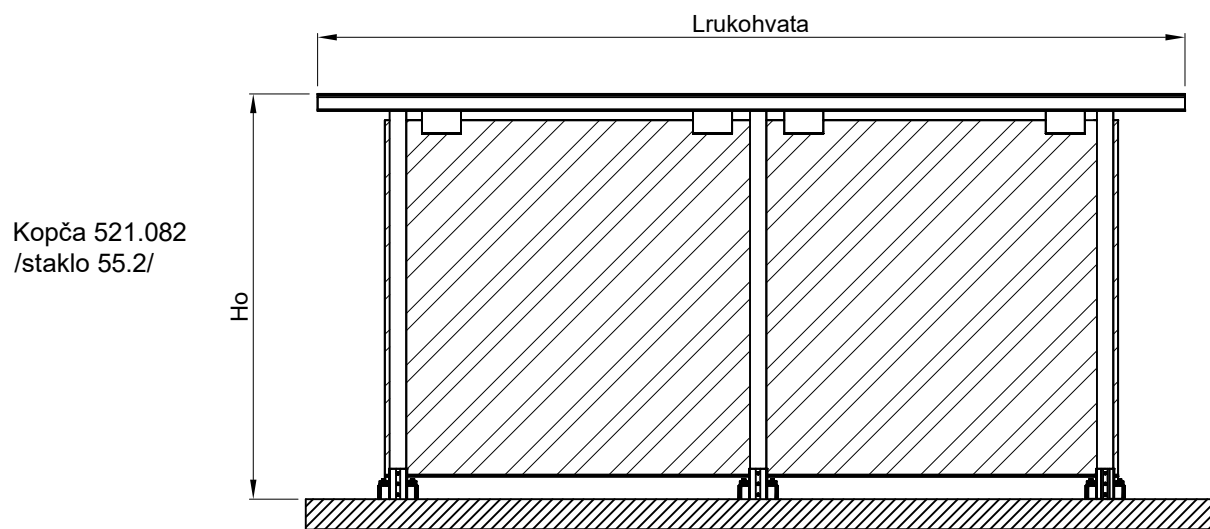

Staklena ograda sa kontinuiranom vodilicom (staklo 55.2)

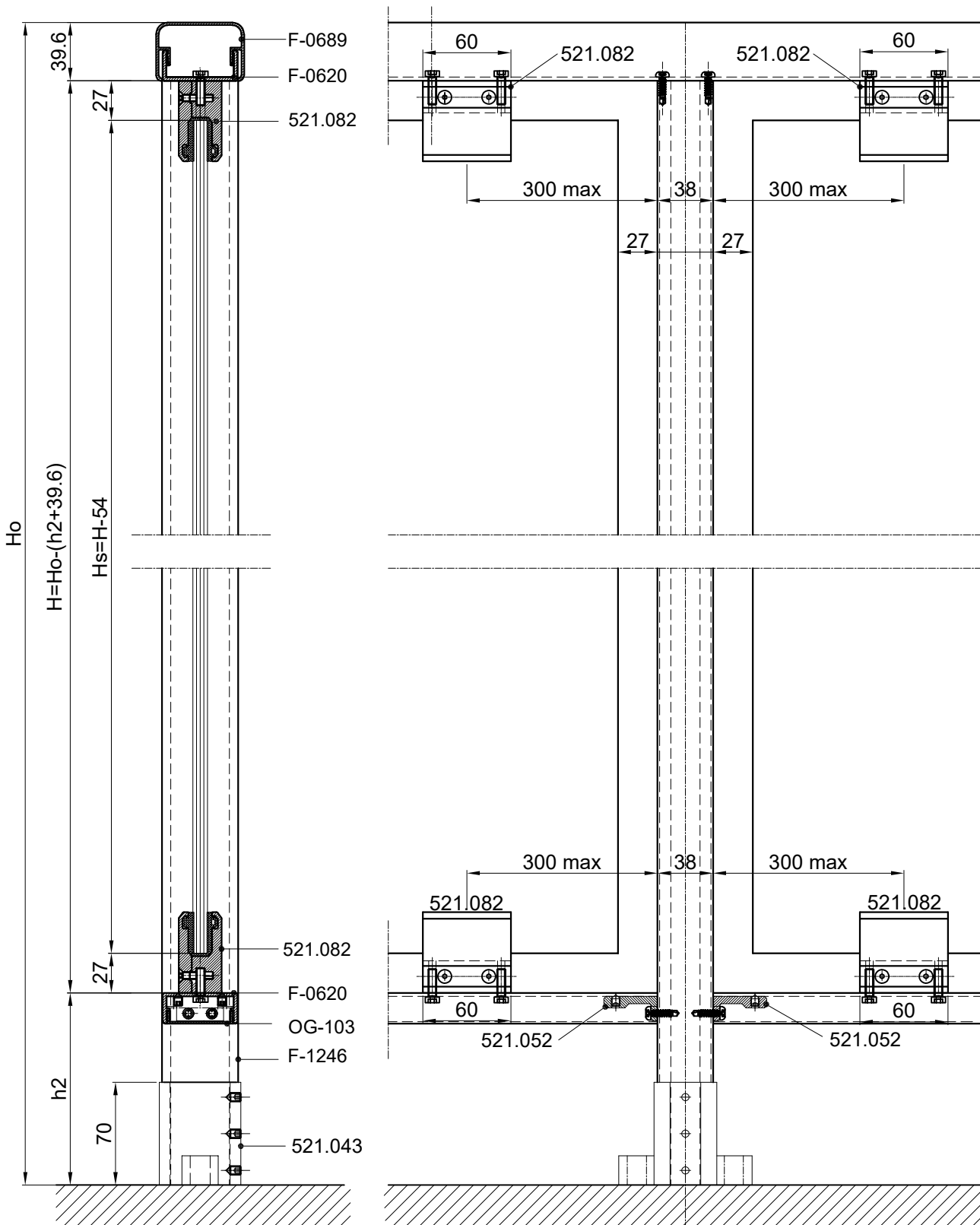
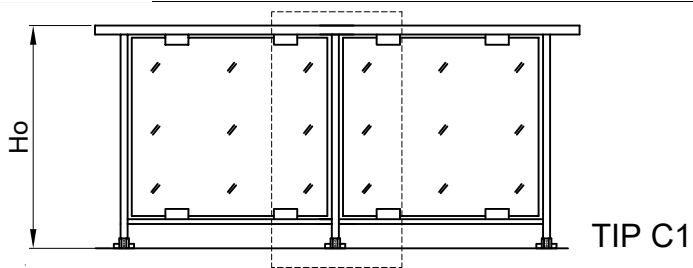

M 1:4

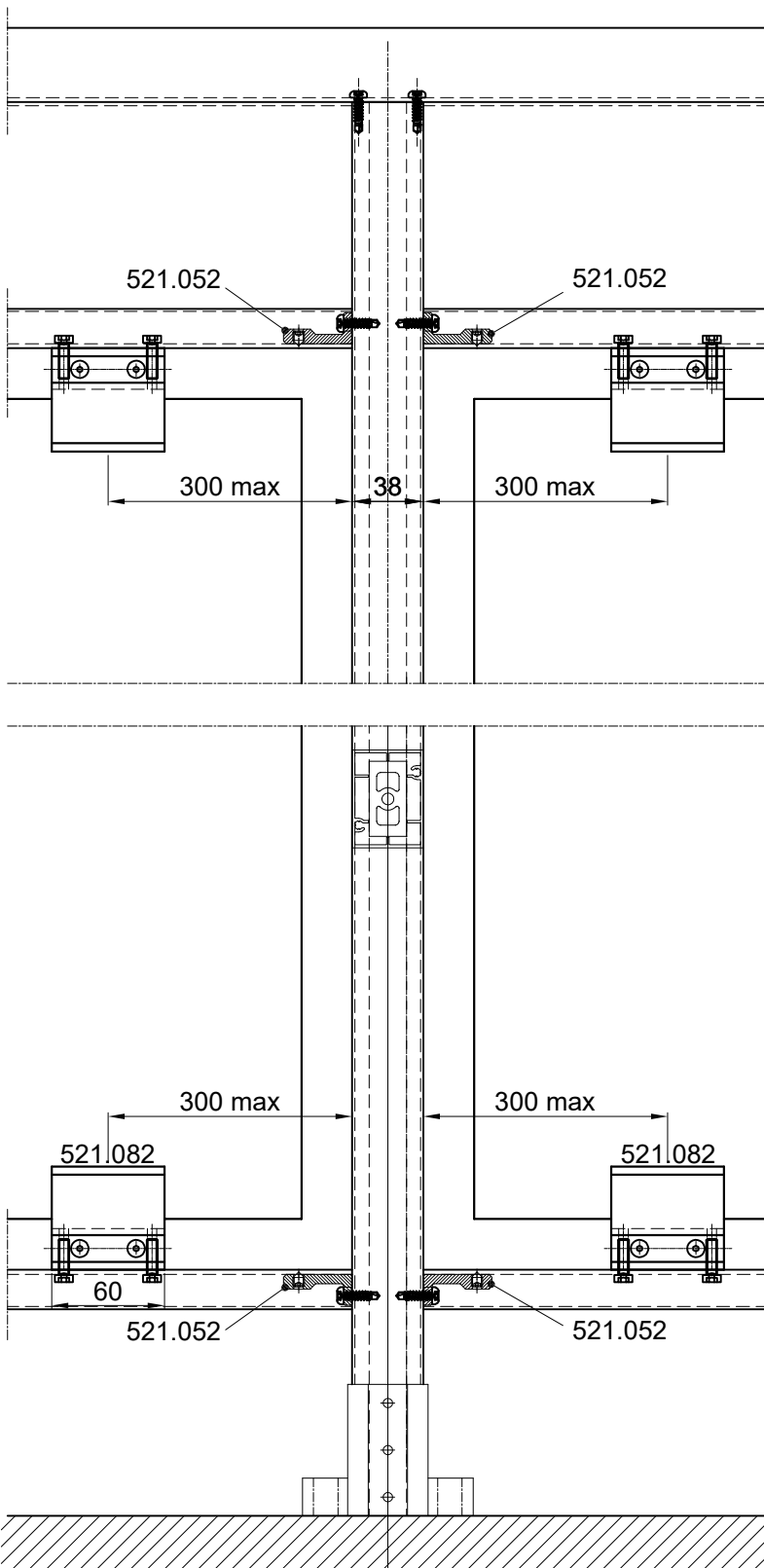
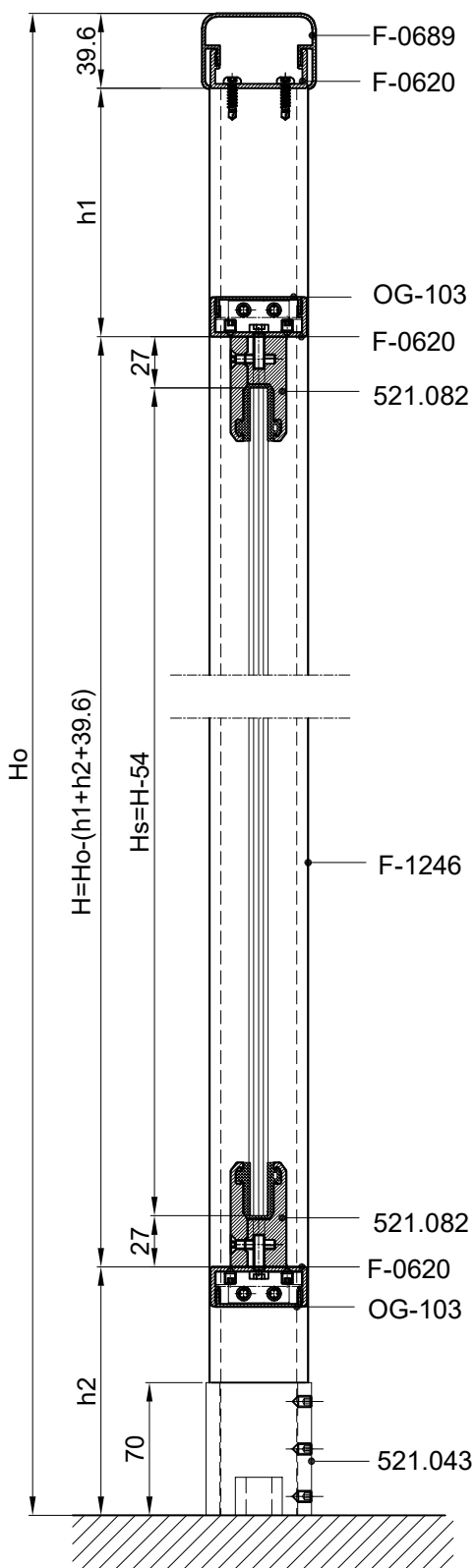
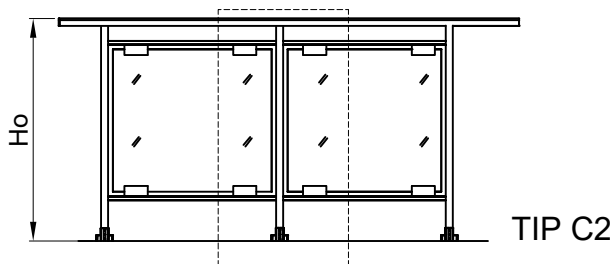

M 1:4

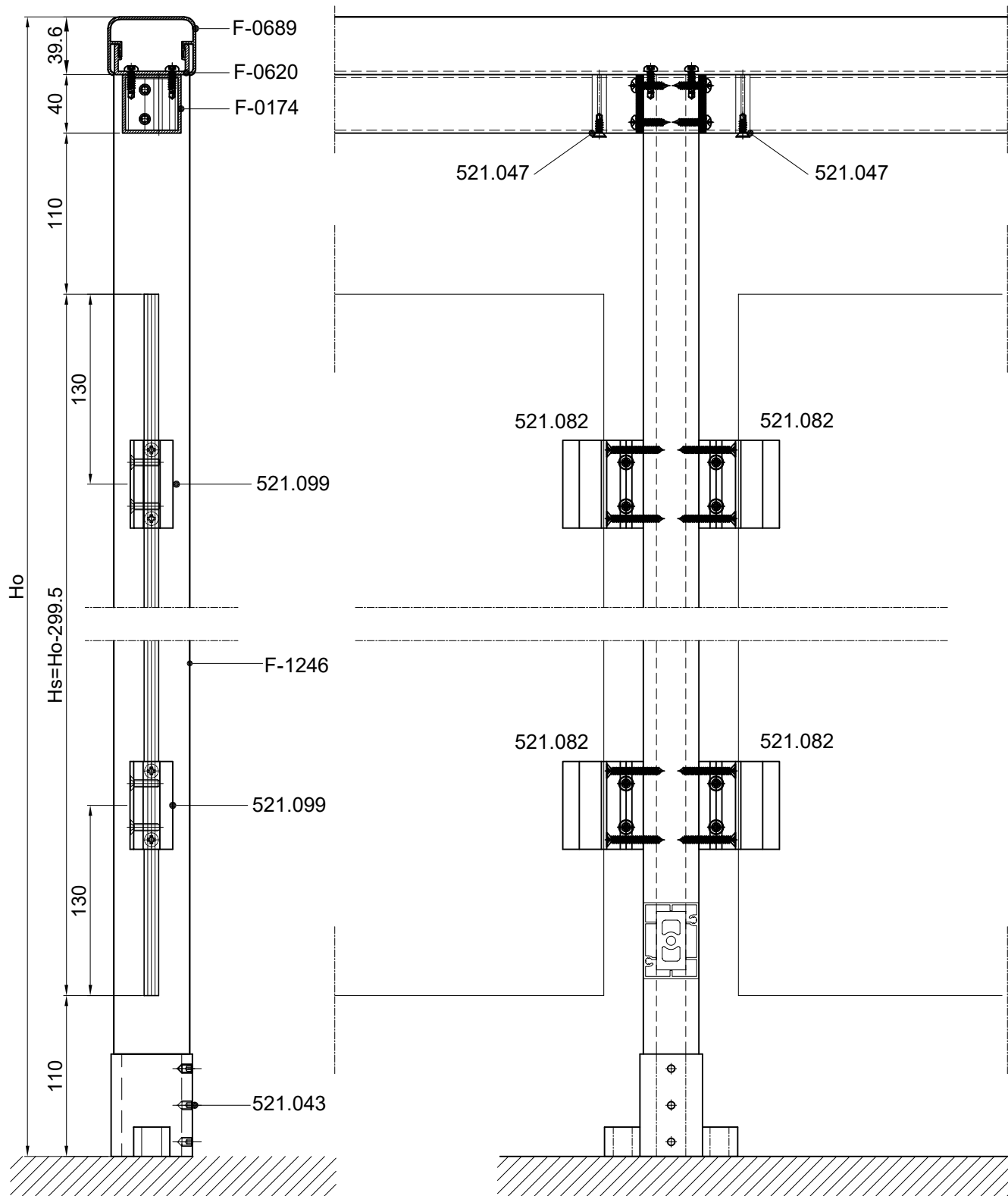
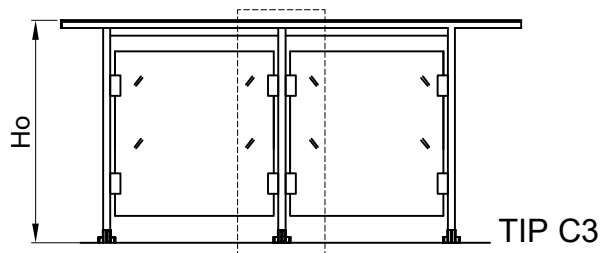

M 1:4

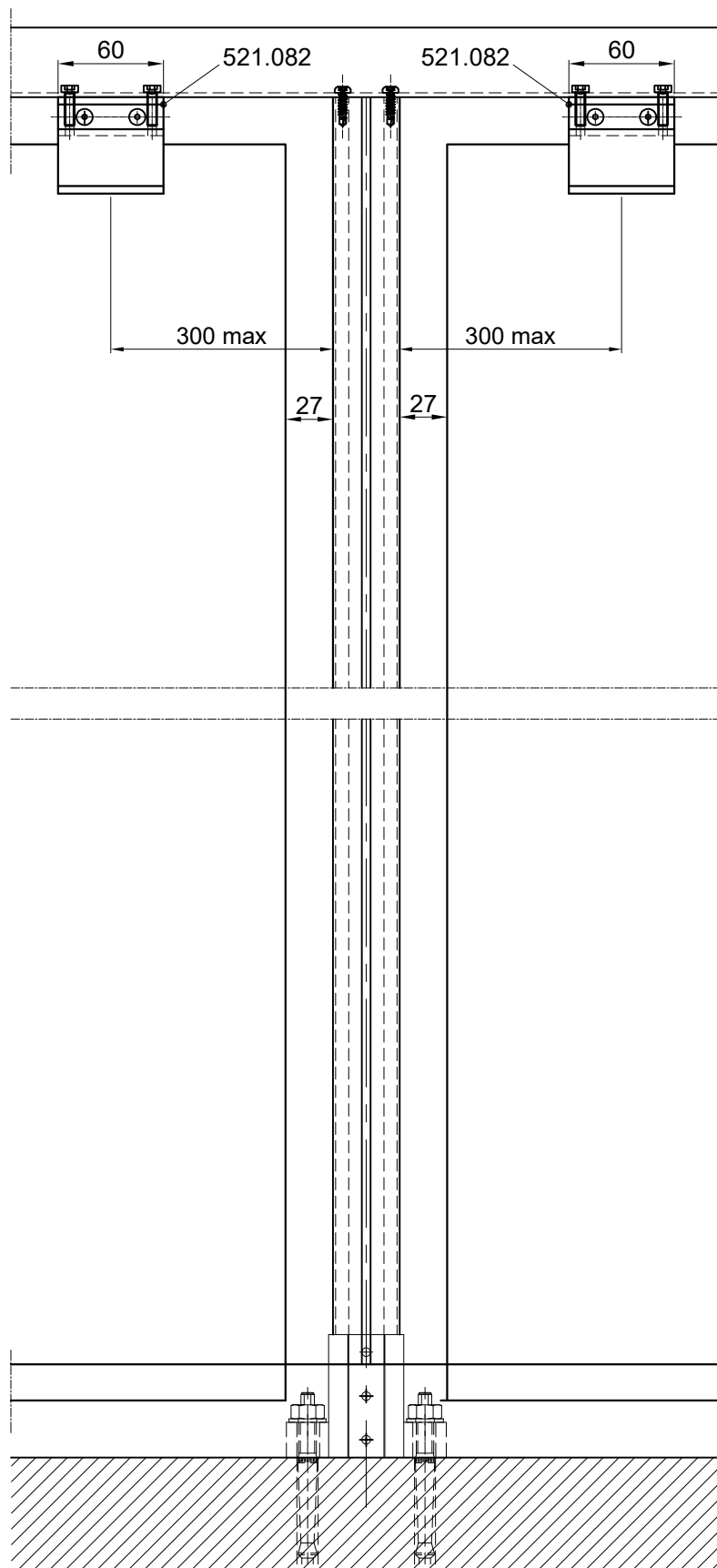
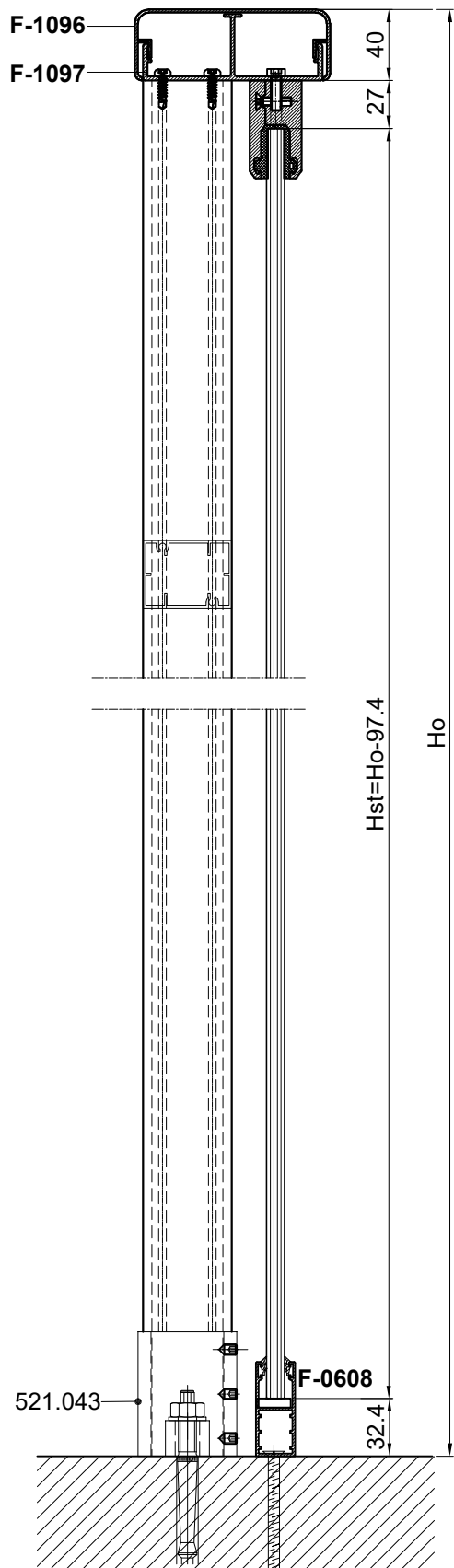
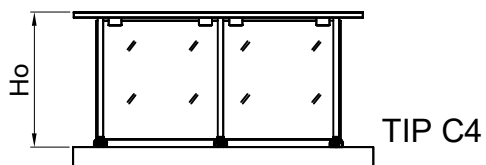

M 1:4

Držač stakla 521.045 /za staklo 44.2

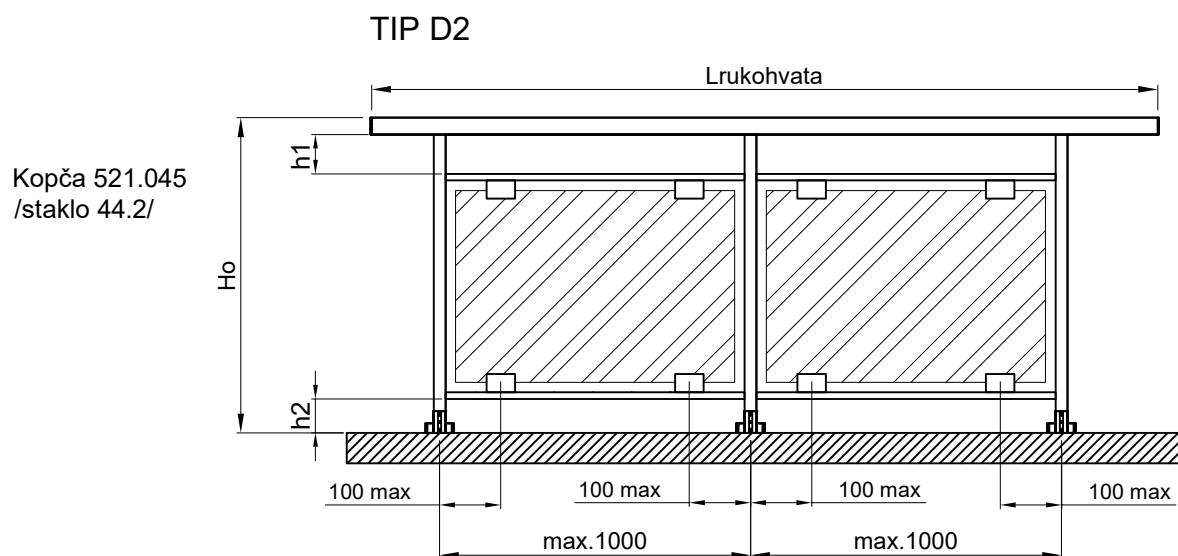
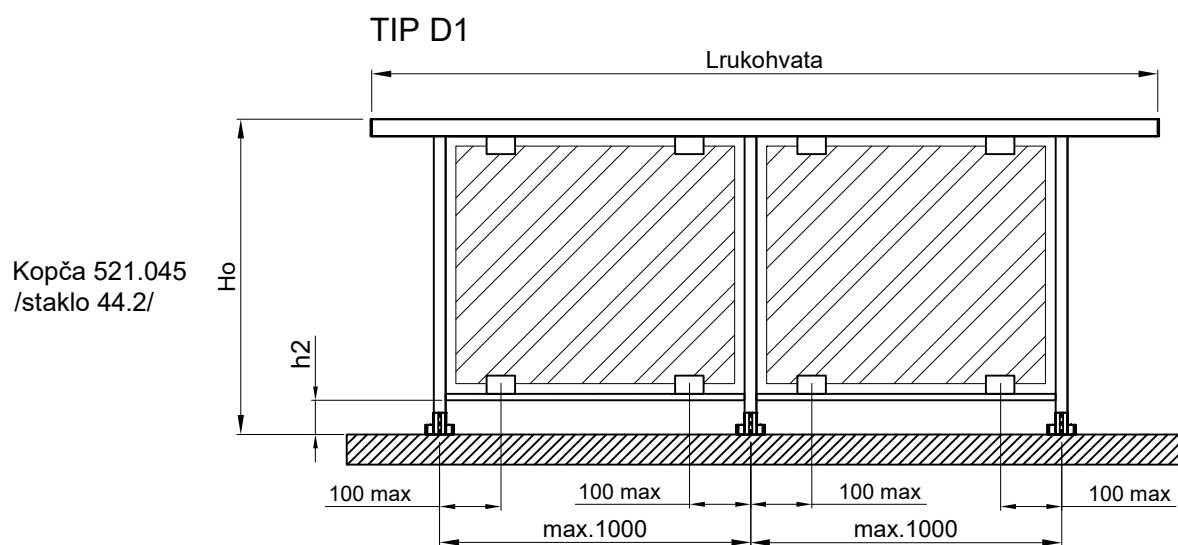

TIP B2



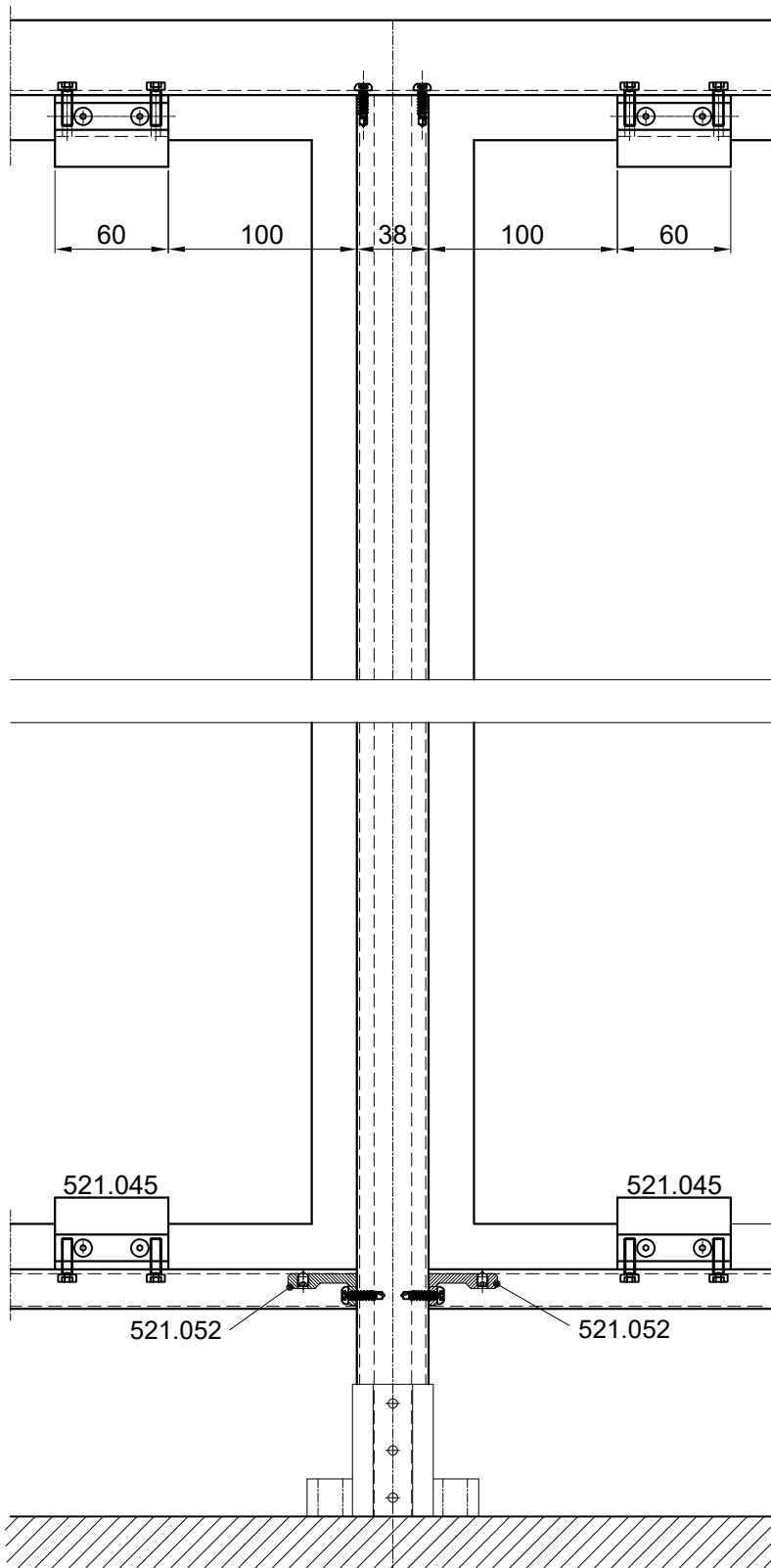
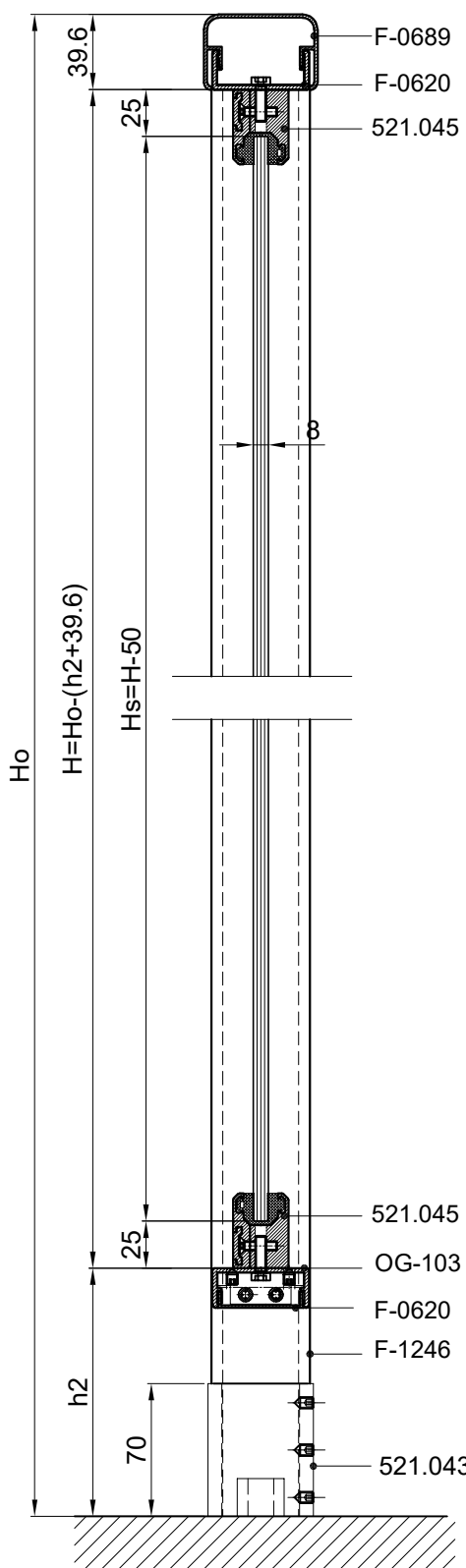
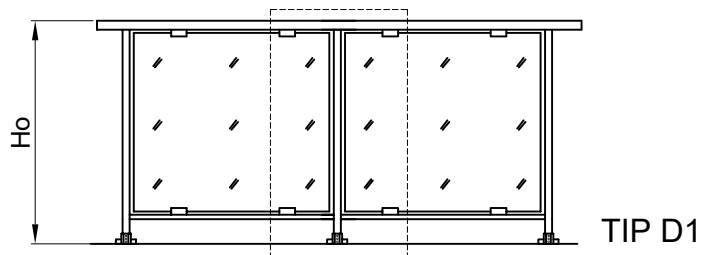

M 1:4

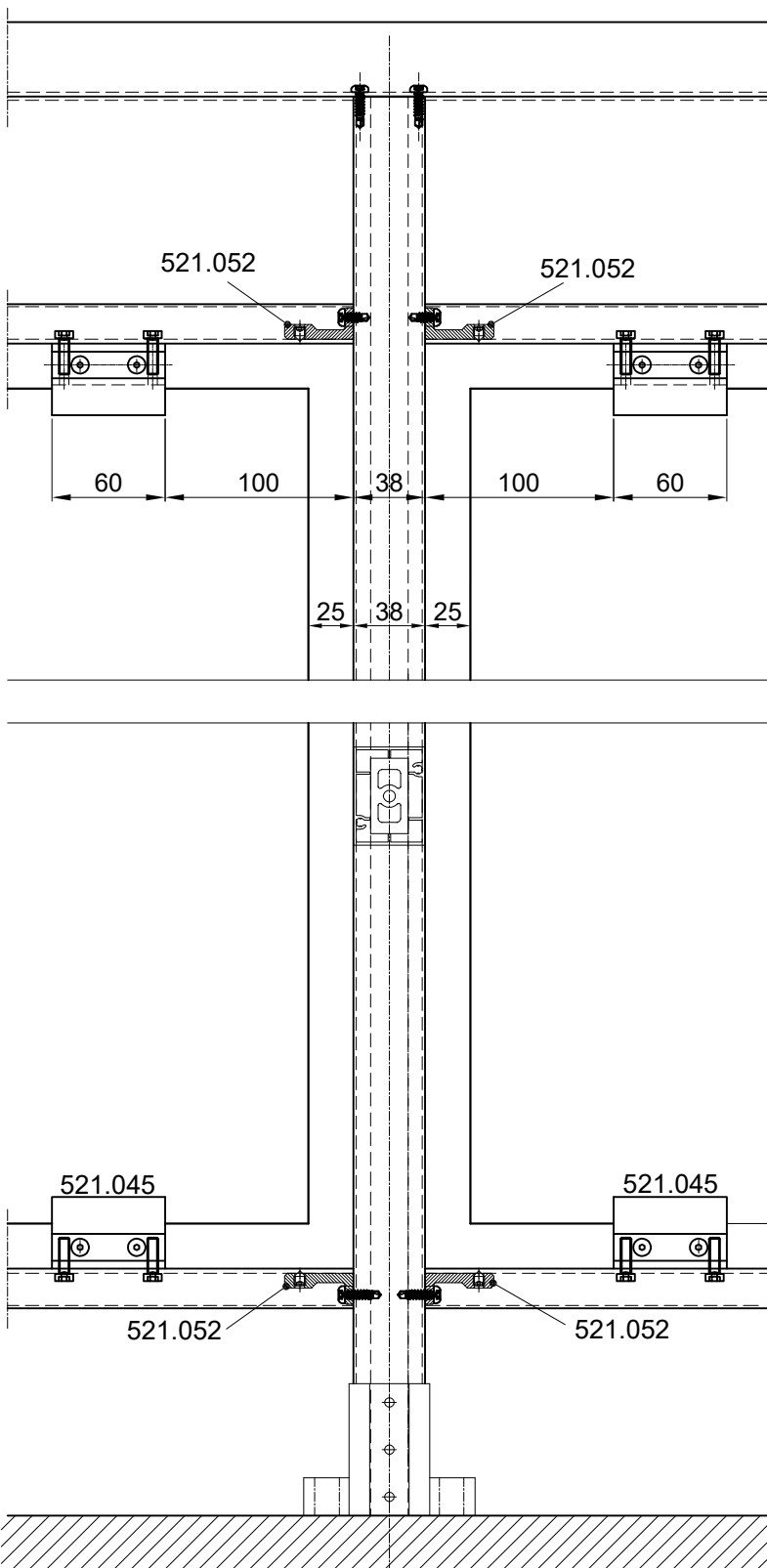
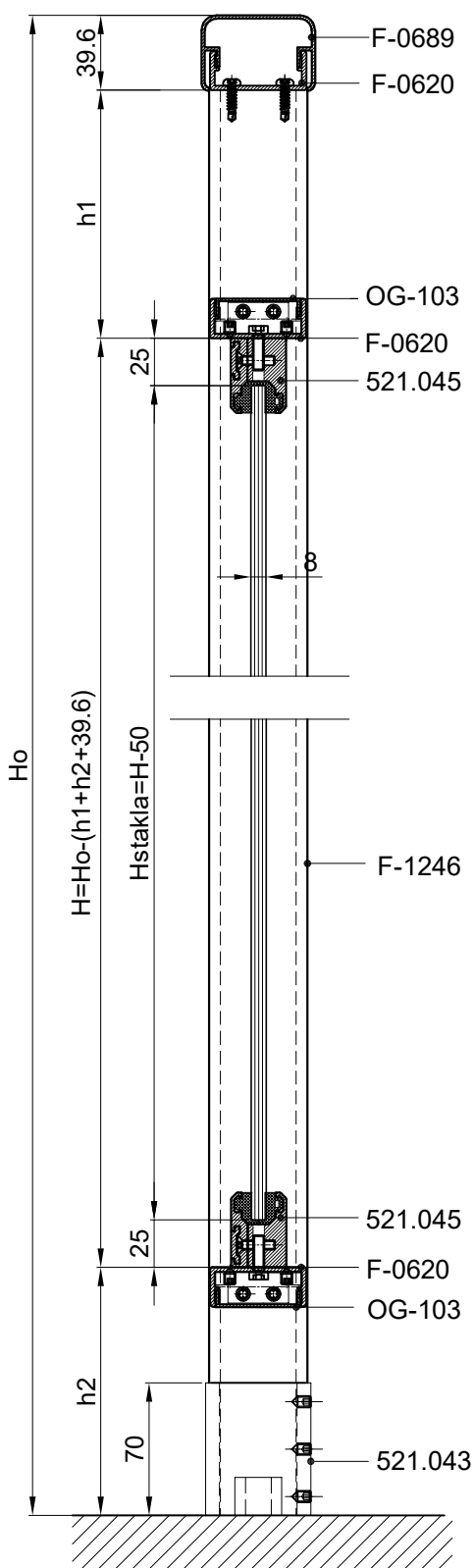
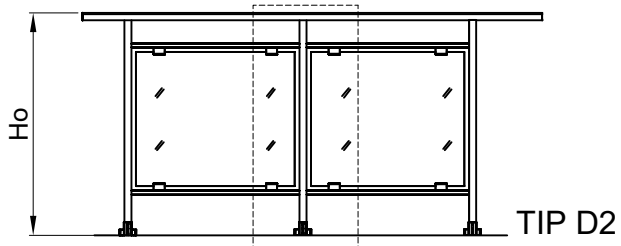

M 1:4

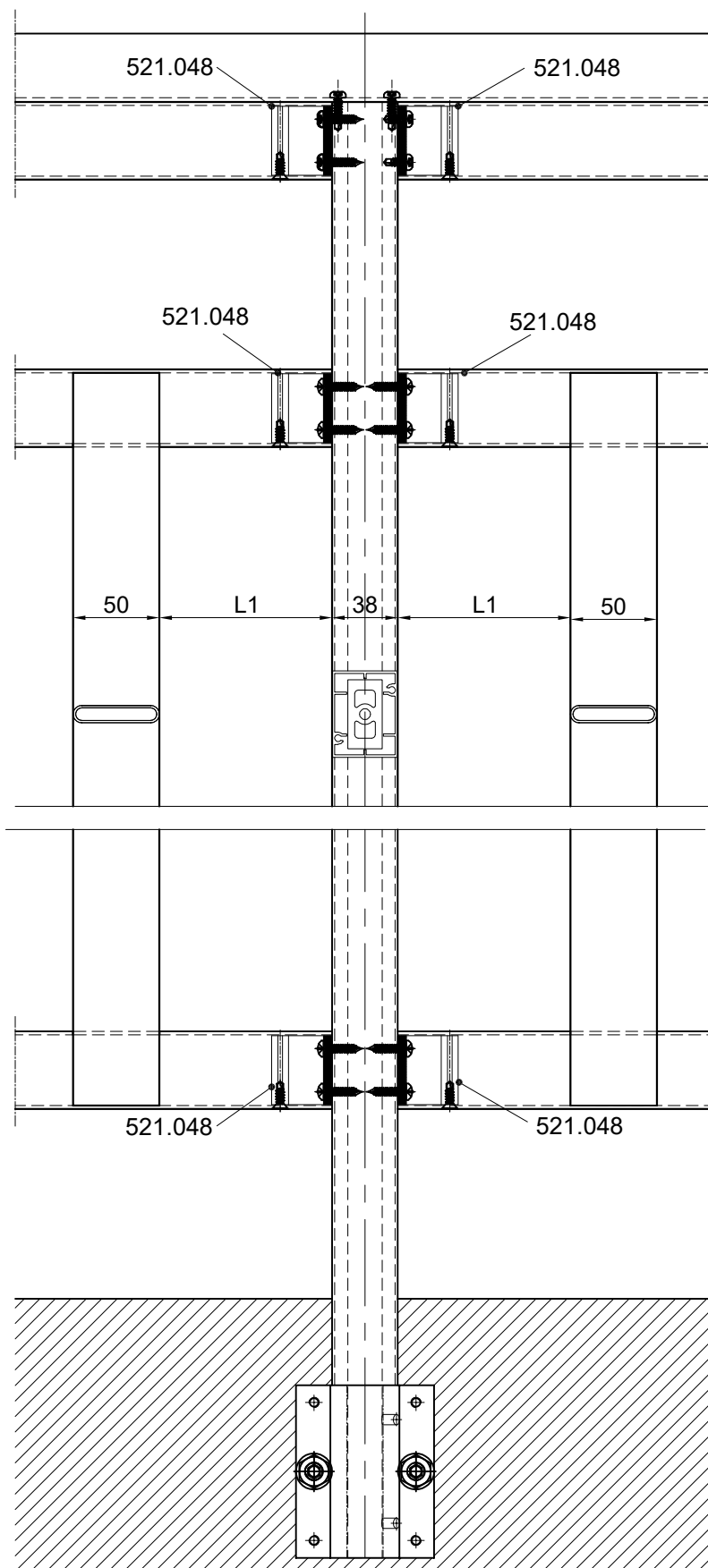
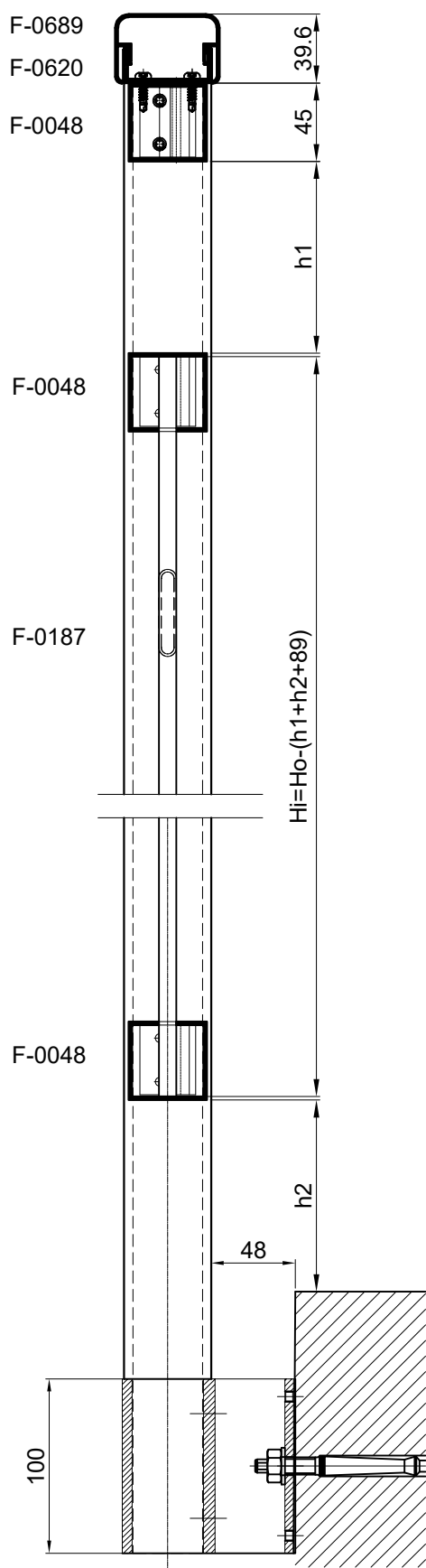



# Obrada i montaža



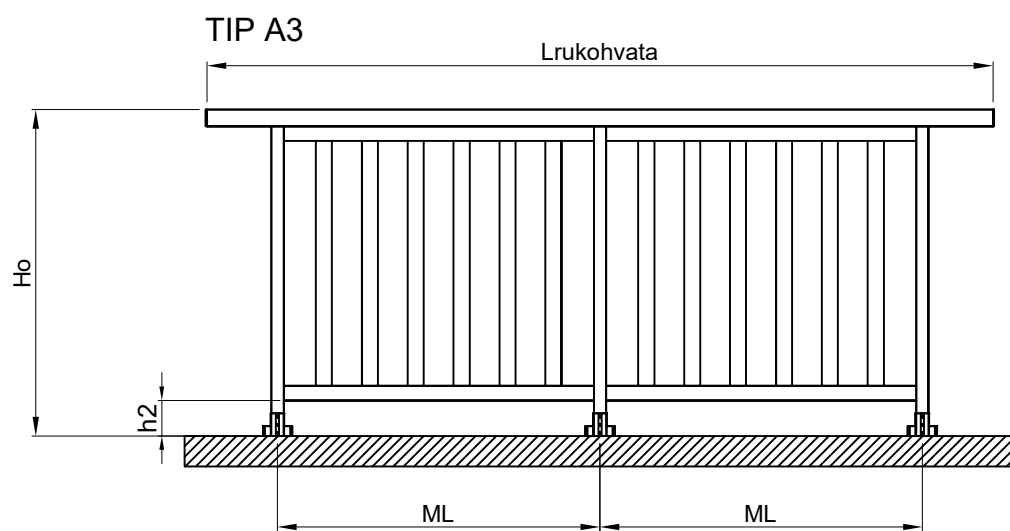
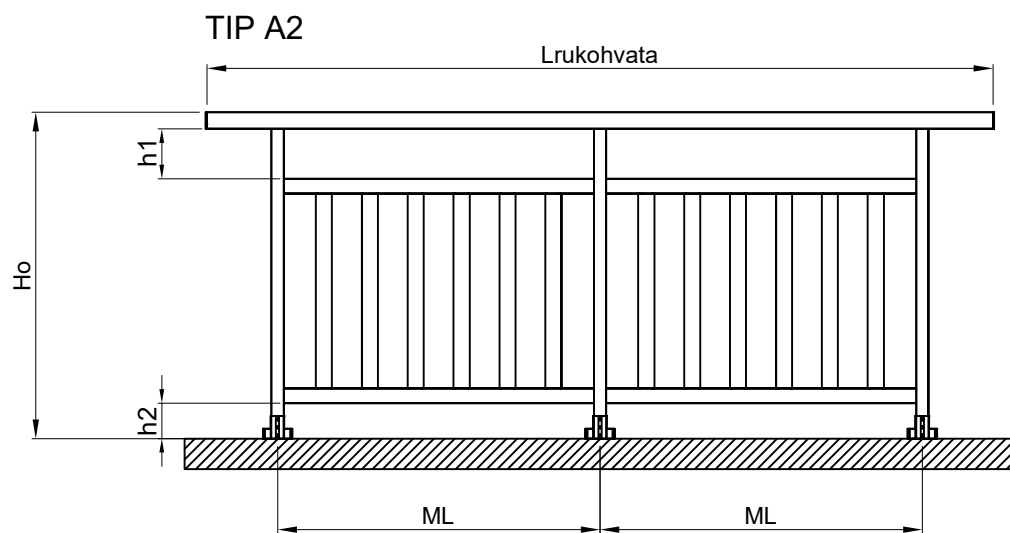
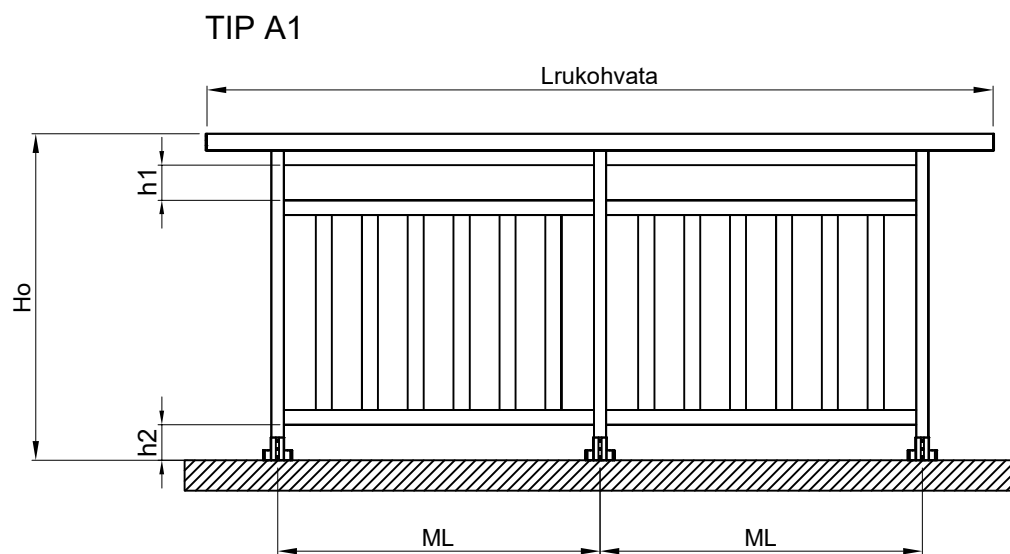



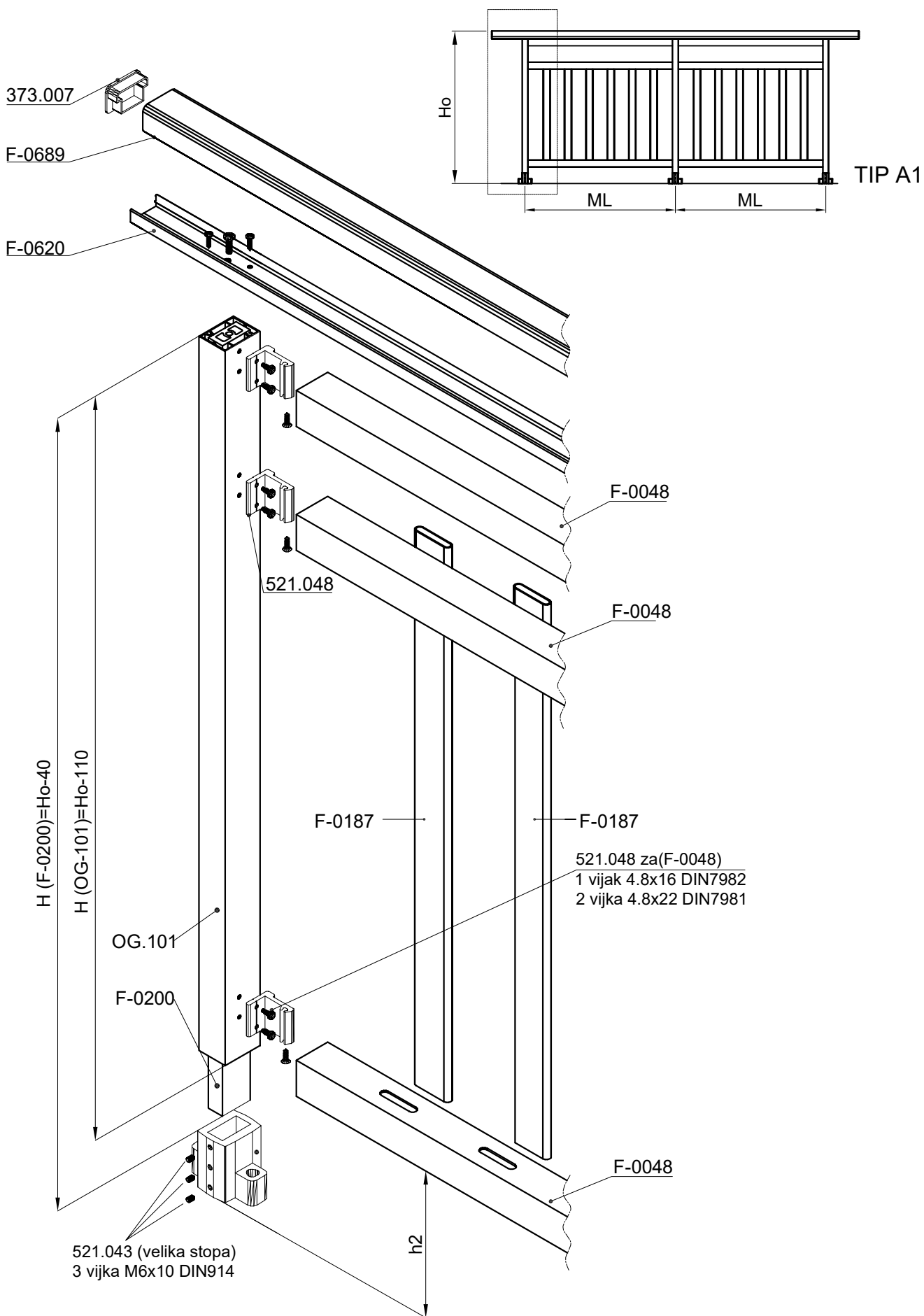

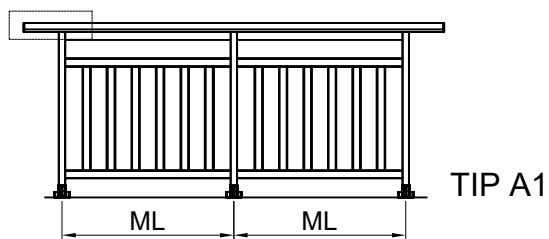

373.007 PVC  
čep za rukohvat  
F-0689

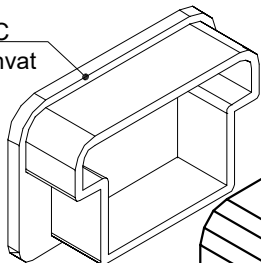

F-0689  
rukohvat

2 vijka 4.8x19 DIN7981  
1 Vijak M8x30 DIN 933  
za spajanje (F-0620)  
podrukohvata sa  
al. stubom (OG-101)

F-620  
podrukohvat

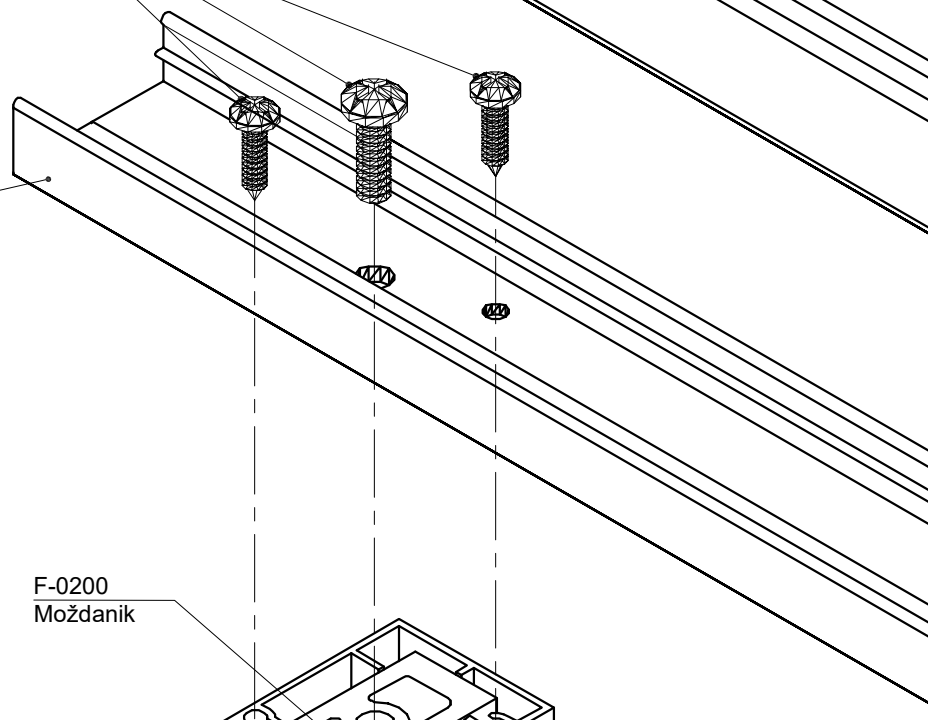

F-020  
Moždanic

OG-101  
Al stub

F-0200  
Moždanik

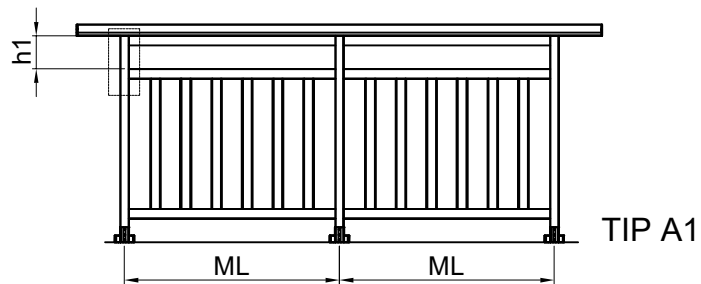

521.048 za(F-0048)  
1 vijak 4.8x16 DIN7982  
2 vijka 4.8x22 DIN7981

(F-0048-prečka pod rukohvatom),  
spaja se preko veznika (521.048)  
za al stub (OG101)

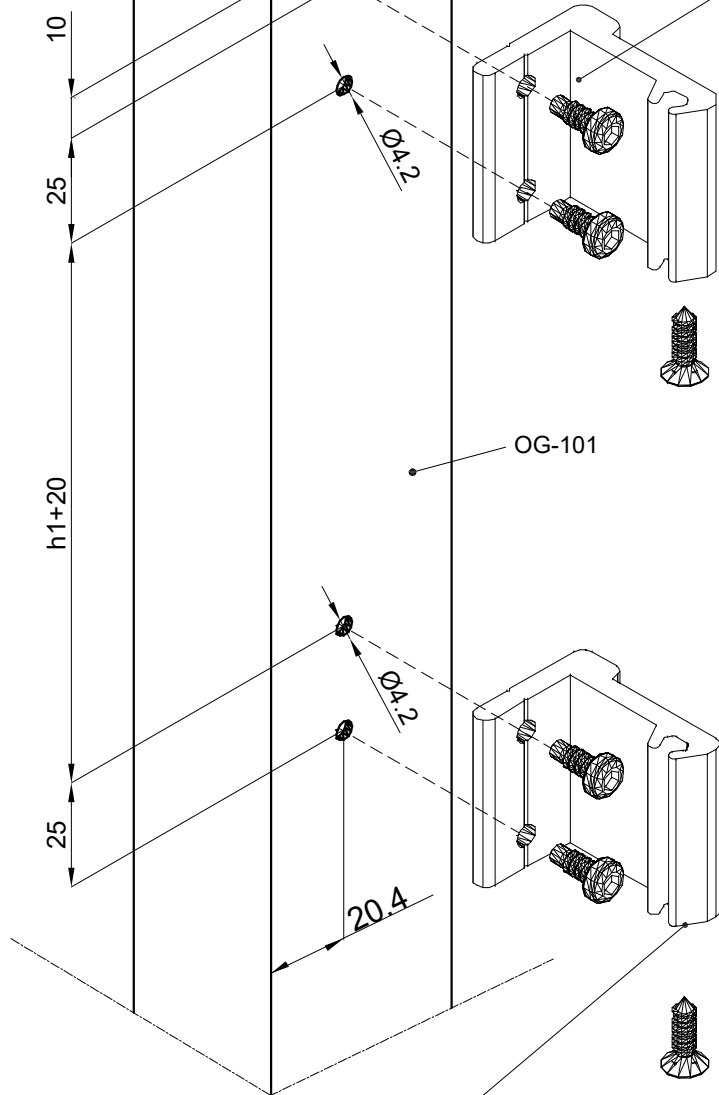

521.048 za(F-0048)  
1 vijak 4.8x16 DIN7982  
2 vijka 4.8x22 DIN7981

(F-0048-sr. horizont. prečka),  
spaja se preko veznika (521.048)  
za al stub (OG101)

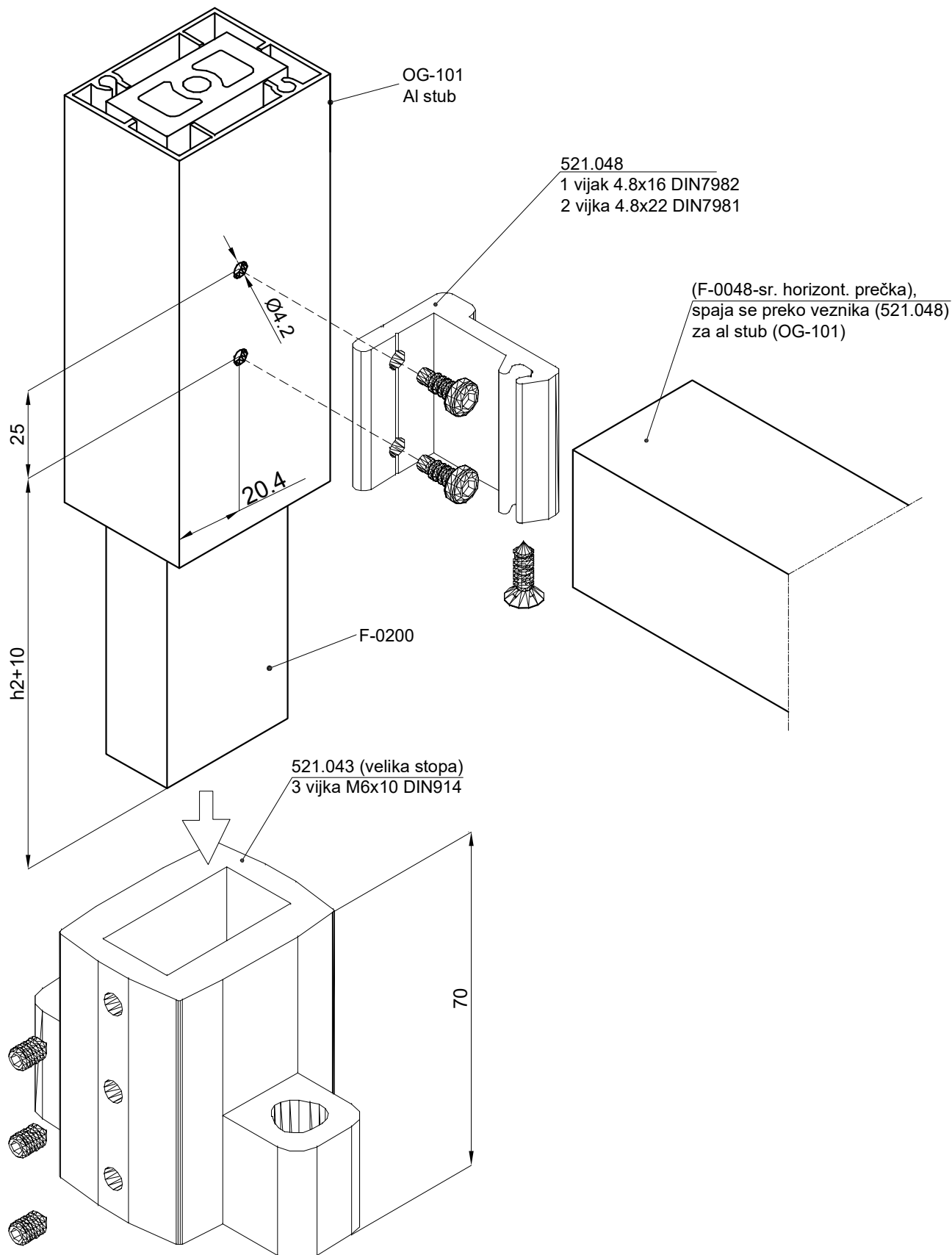
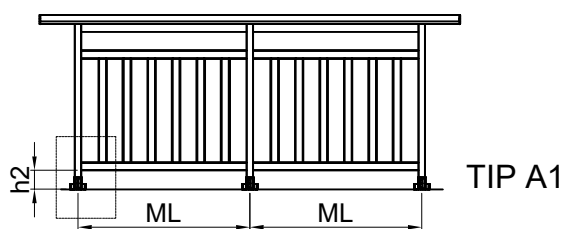

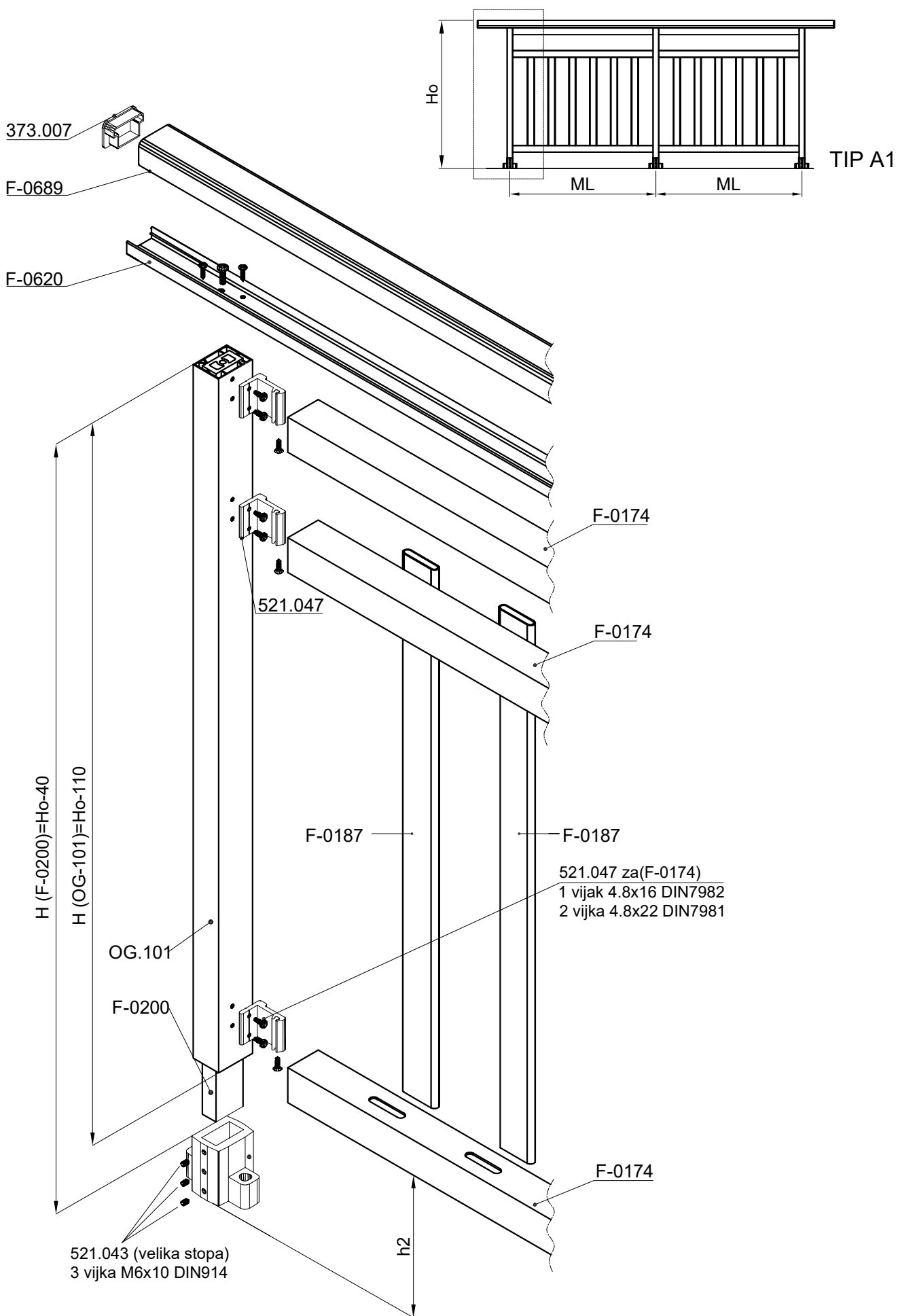

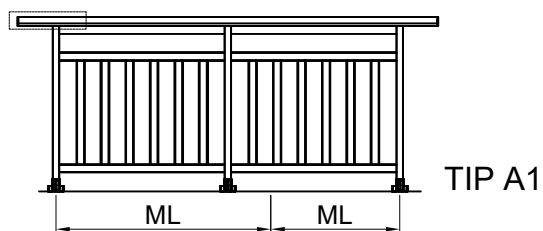

373.007 PVC  
čep za rukohvat  
F-0689

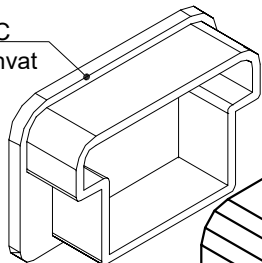

F-0689  
rukohvat

2 vijka 4.8x19 DIN7981  
1 Vijak M8x30 DIN 933  
za spajanje (F-0620)  
podrukohvata sa  
al. stubom (OG-101)

F-620  
podrukohvat

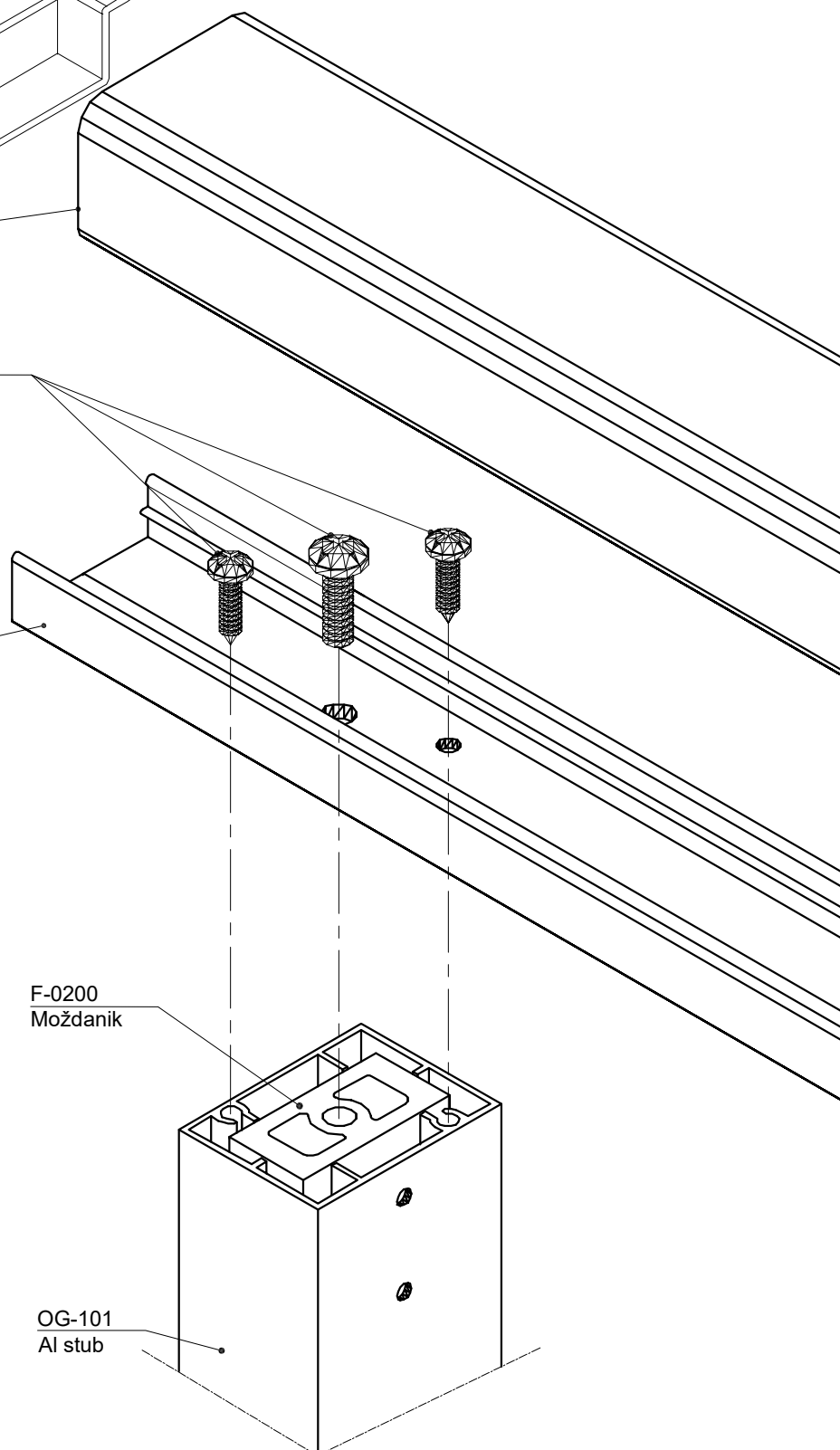

F-020  
Moždanik

OG-101  
Al stub

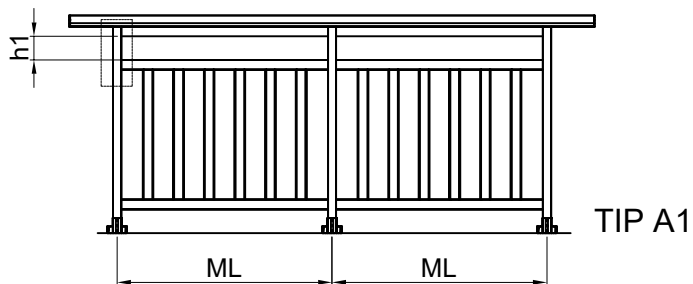

F-0200  
Moždanik

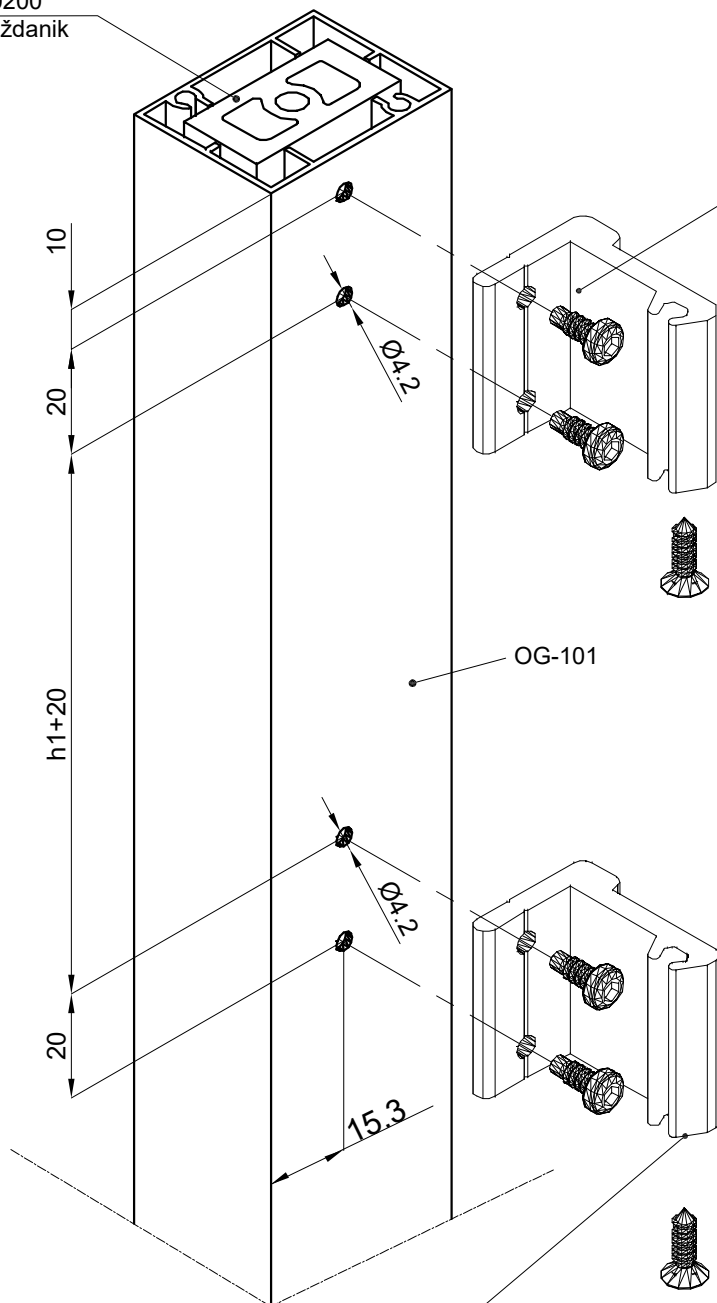

521.047 za(F-0174)  
1 vijak 4.8x16 DIN7982  
2 vijka 4.8x22 DIN7981

(F-0174-prečka pod rukohvatom),  
spaja se preko veznika (521.047)  
za al stub (OG101)

521.047 za(F-0174)  
1 vijak 4.8x16 DIN7982  
2 vijka 4.8x22 DIN7981

(F-0174-sr. horizont. prečka),  
spaja se preko veznika (521.047)  
za al stub (OG101)

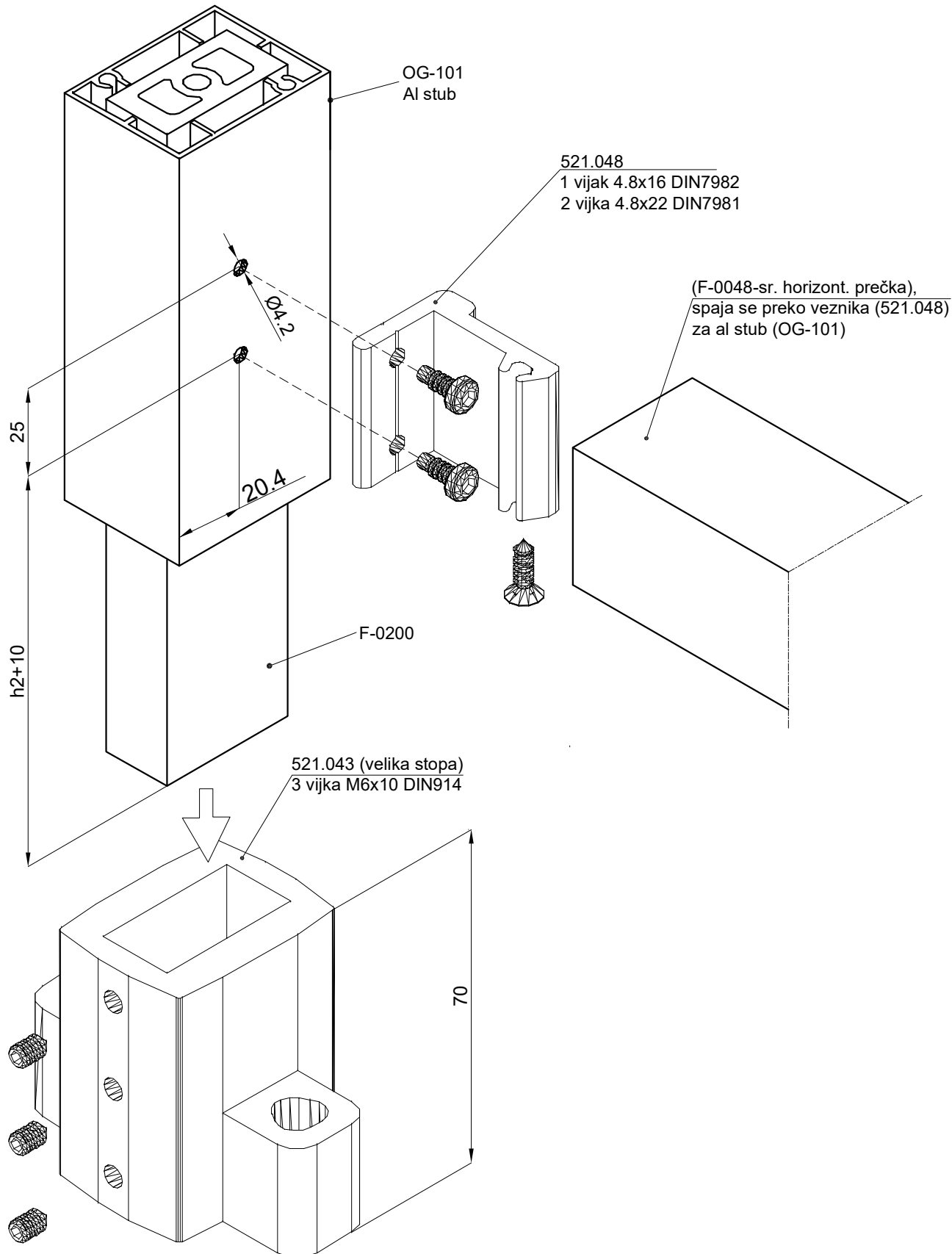
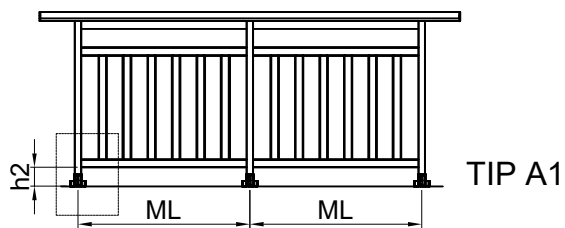

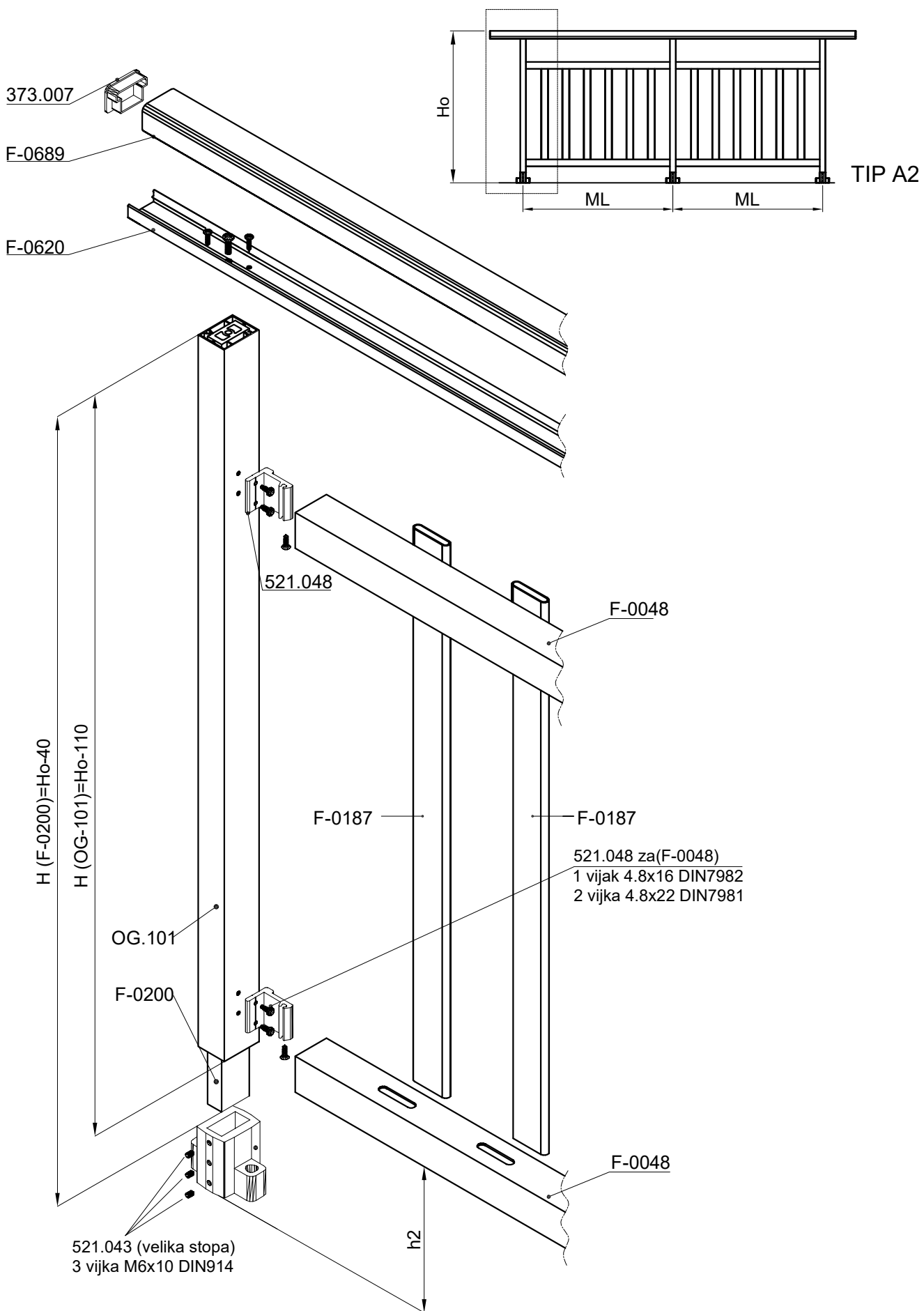

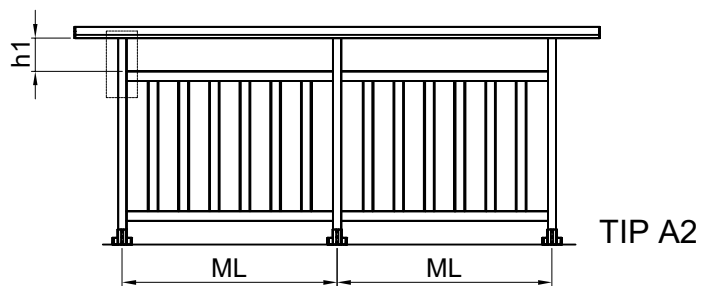

F-0200  
Moždanik

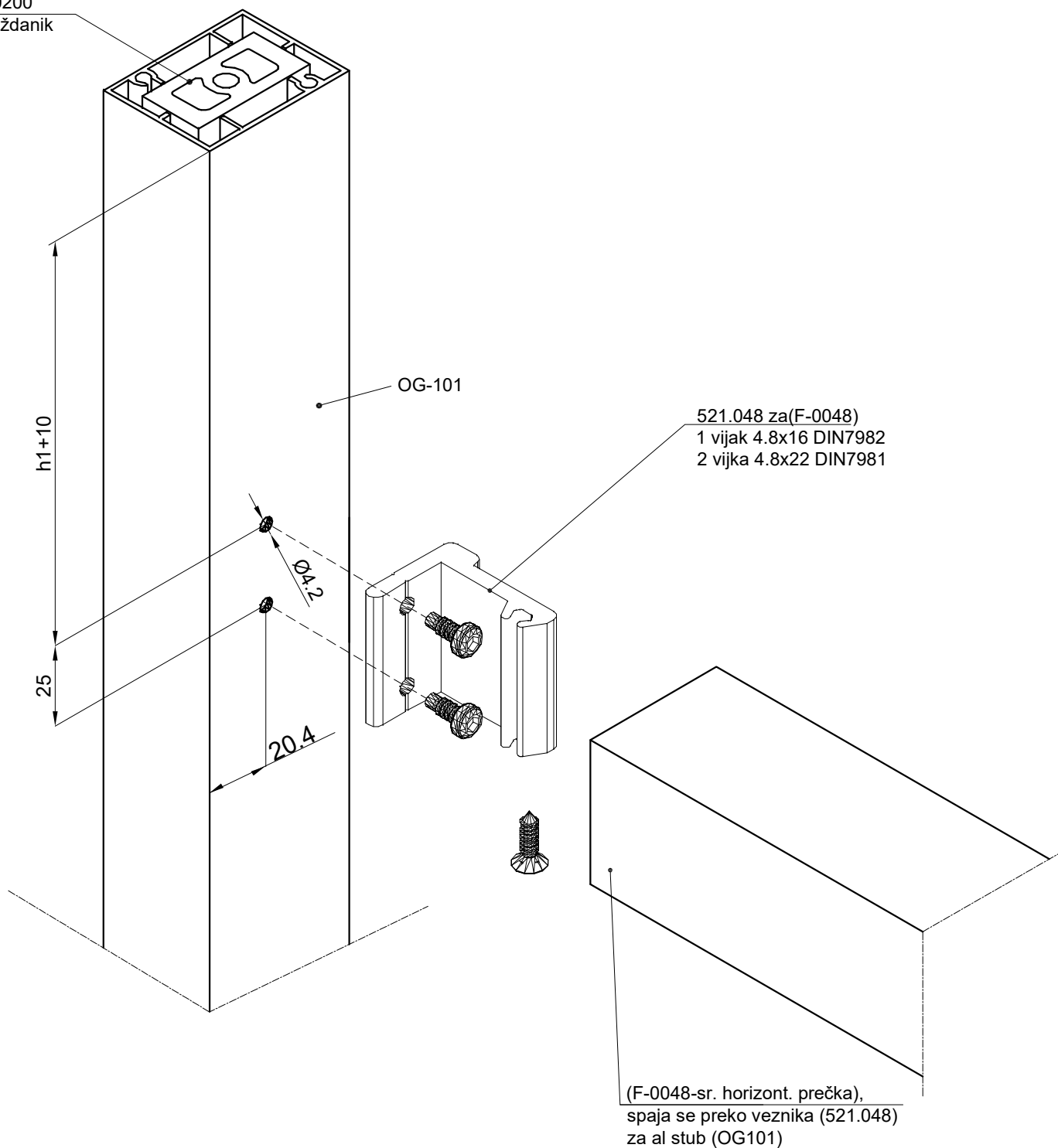

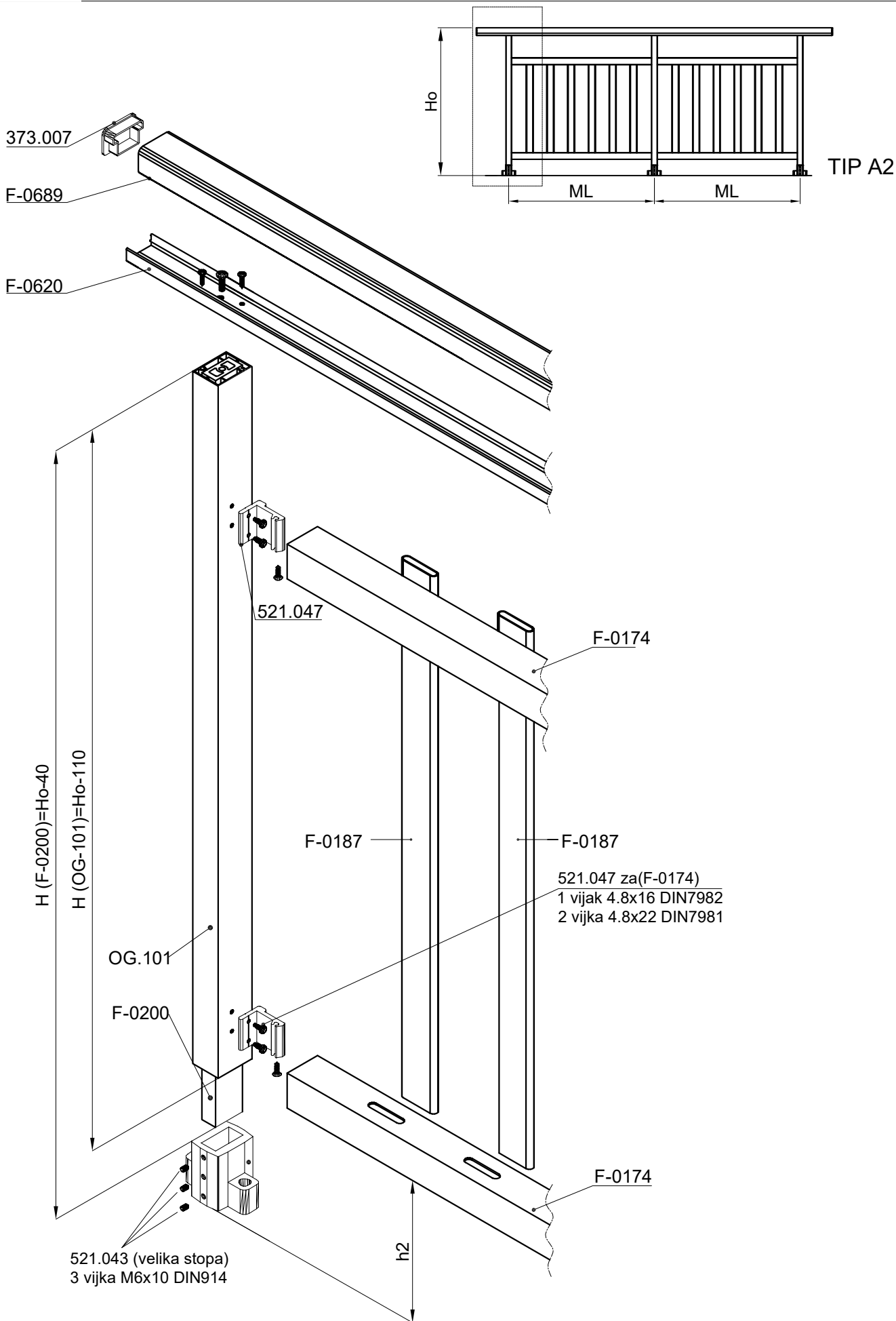

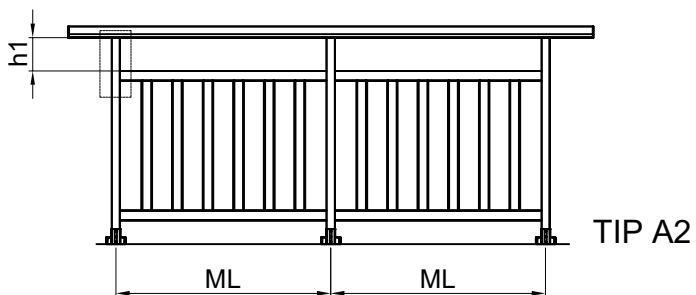

F-0200  
Moždanik

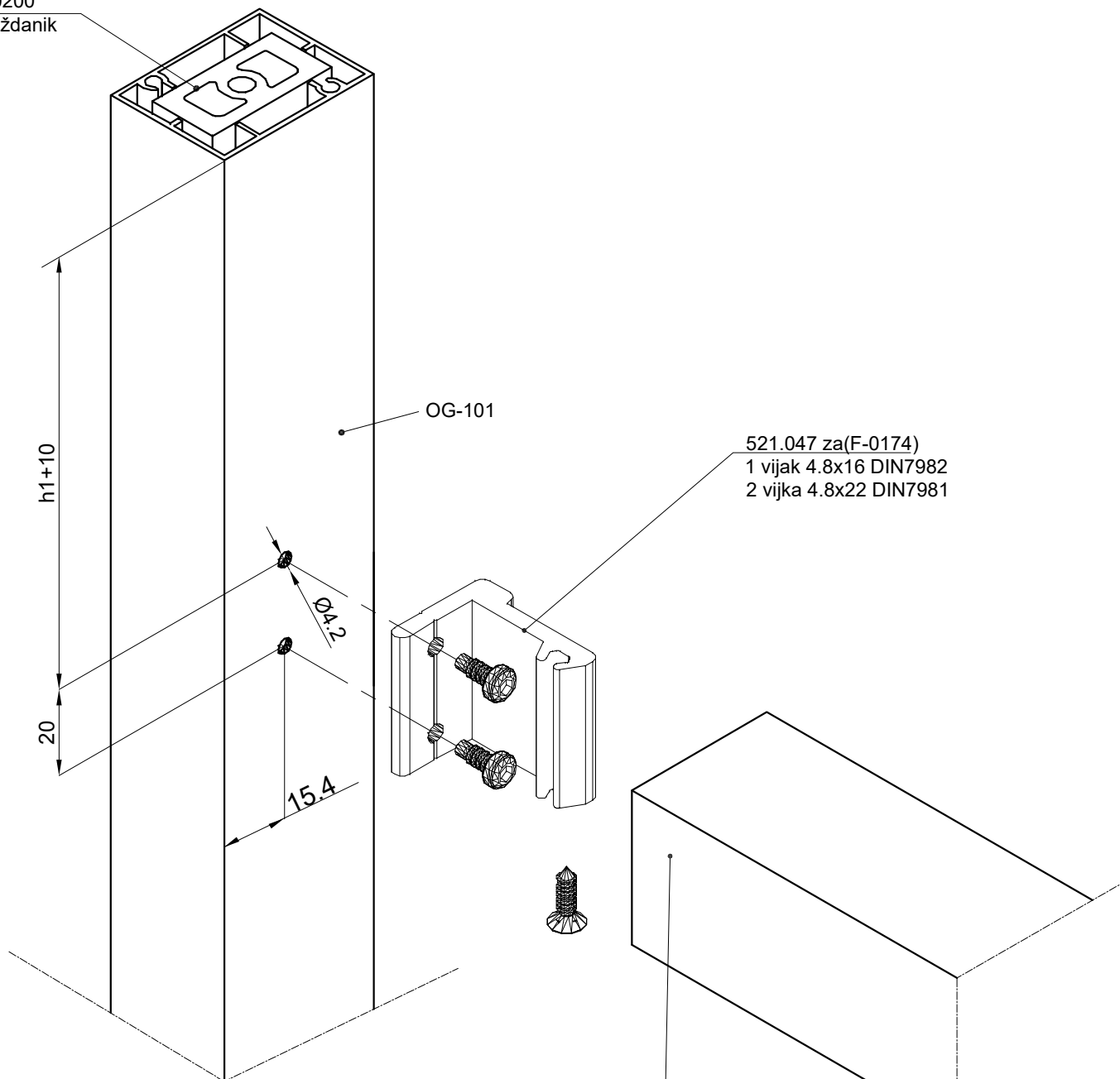

521.047 za(F-0174)  
1 vijak 4.8x16 DIN7982  
2 vijka 4.8x22 DIN7981

(F-0174-sr. horizont. prečka),  
spaja se preko veznika (521.047)  
za al stub (OG101)

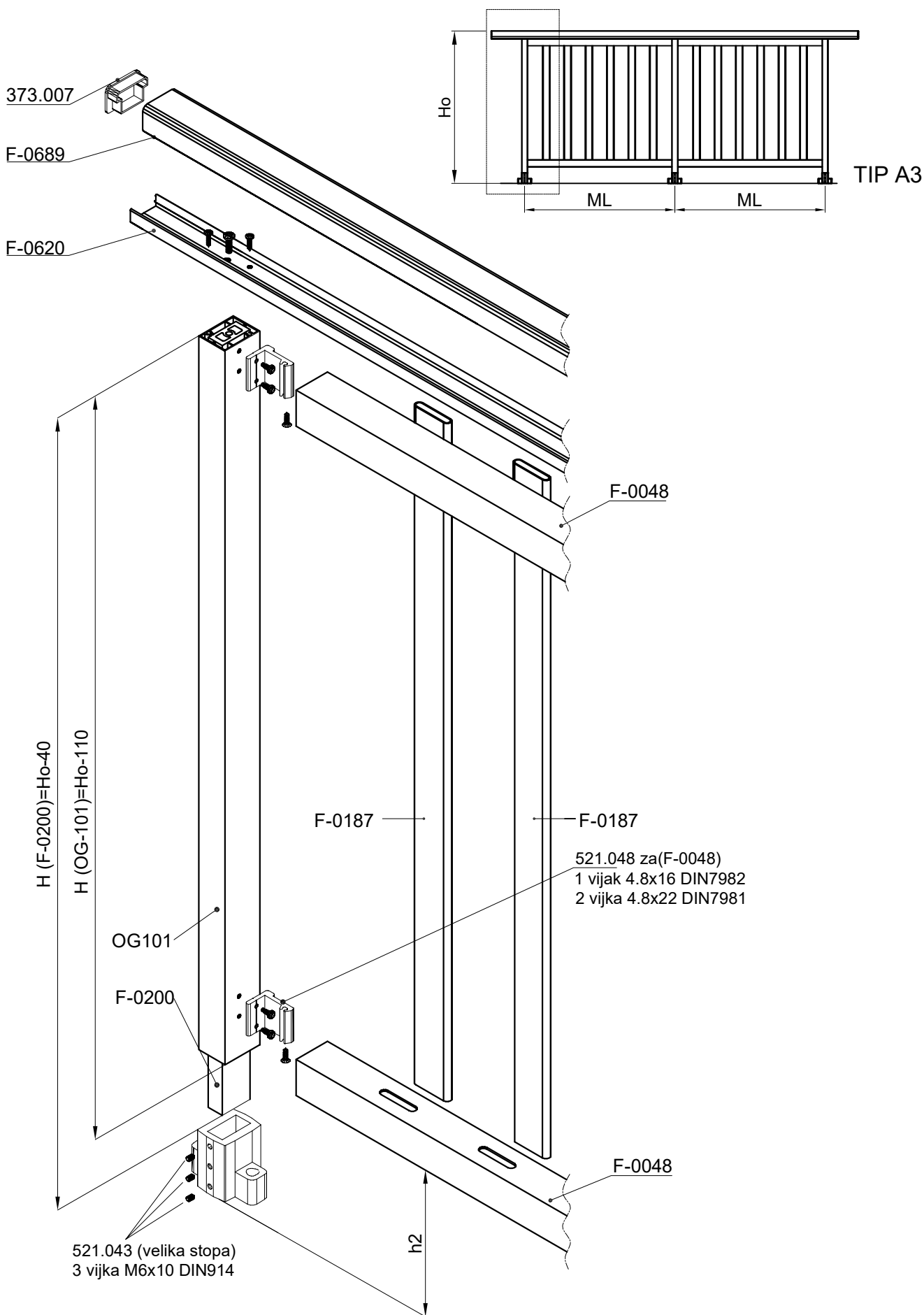

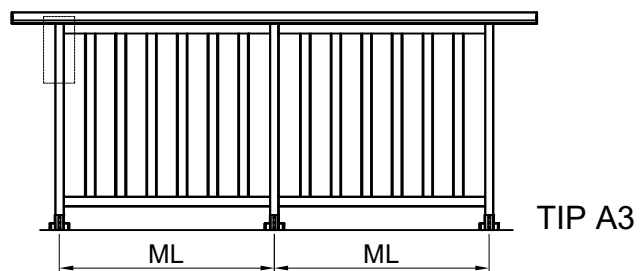

F-0200  
Moždanik

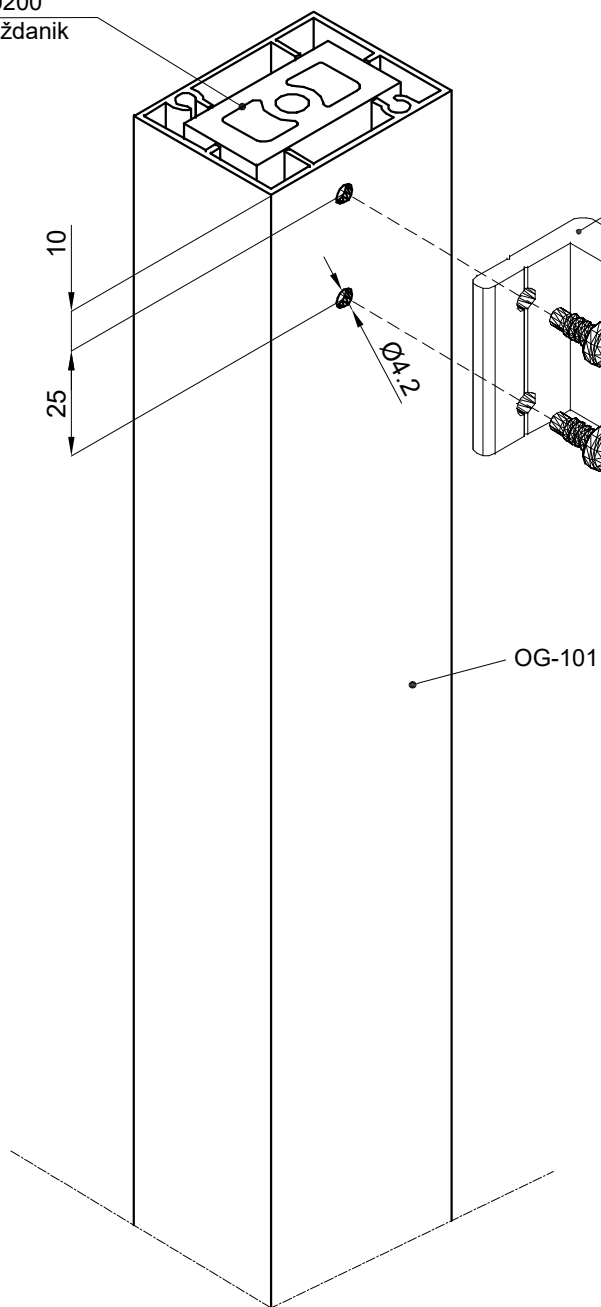

521.048 za(F-0048)  
1 vijak 4.8x16 DIN7982  
2 vijka 4.8x22 DIN7981

(F-0048-prečka pod rukohvatom),  
spaja se preko veznika (521.048)  
za al stub (OG101)

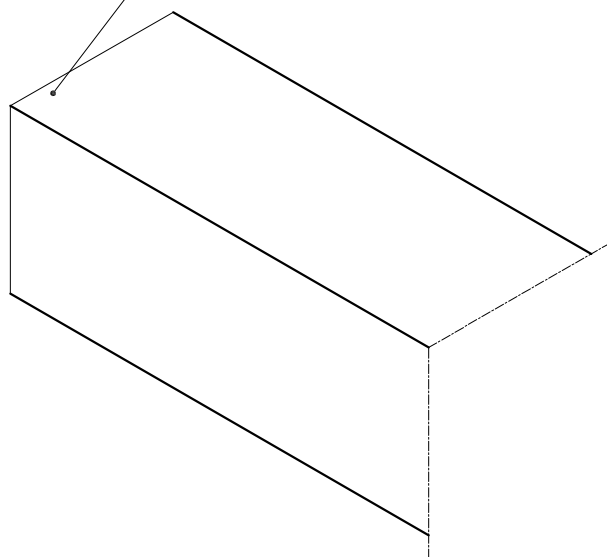

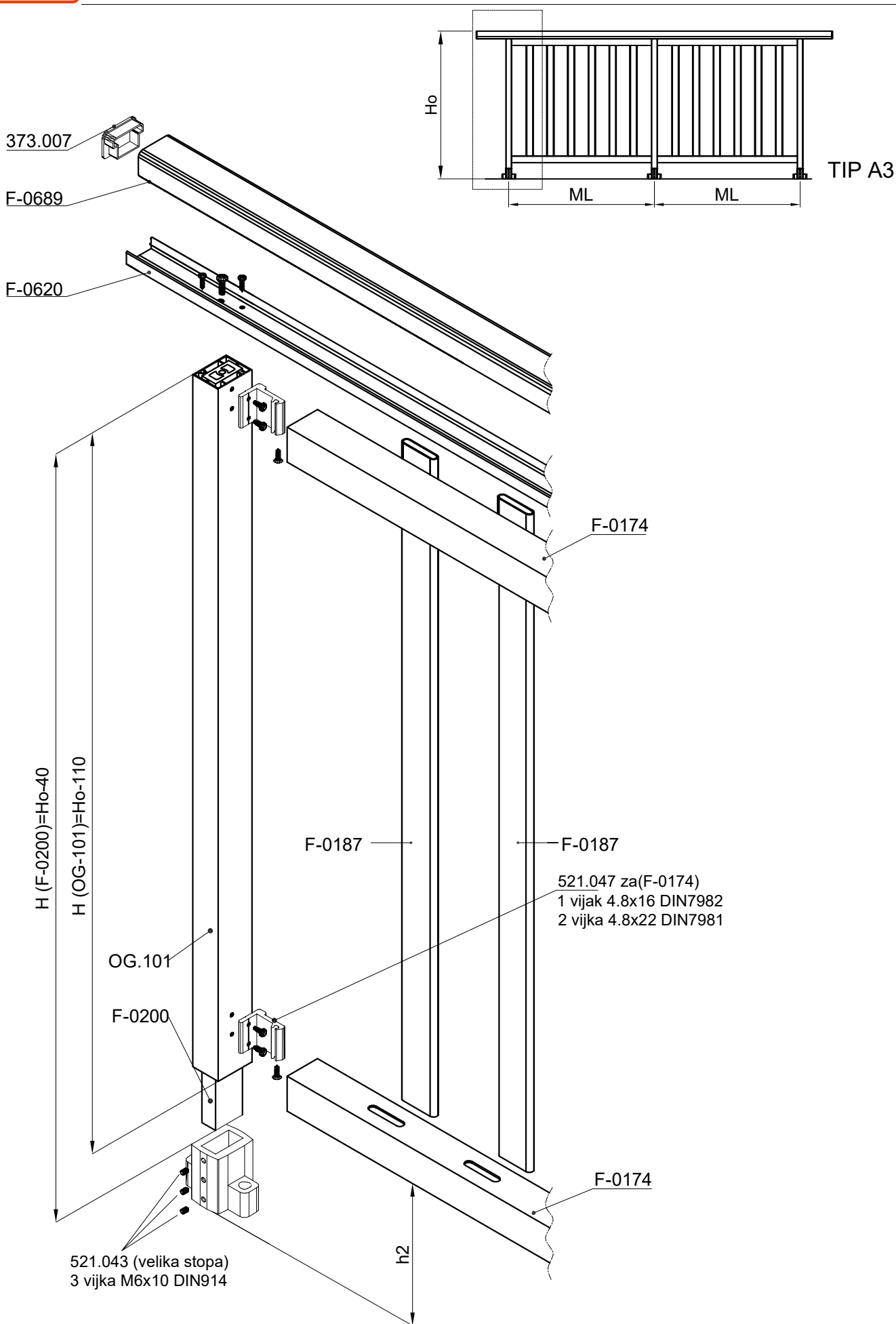

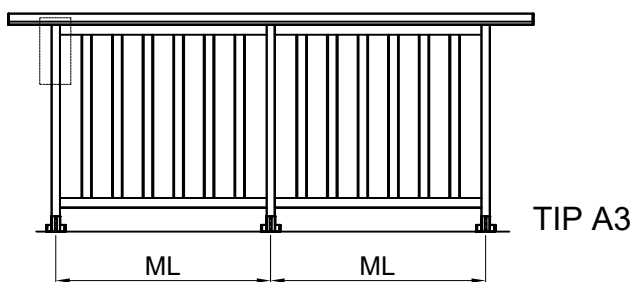

F-0200  
Moždanik

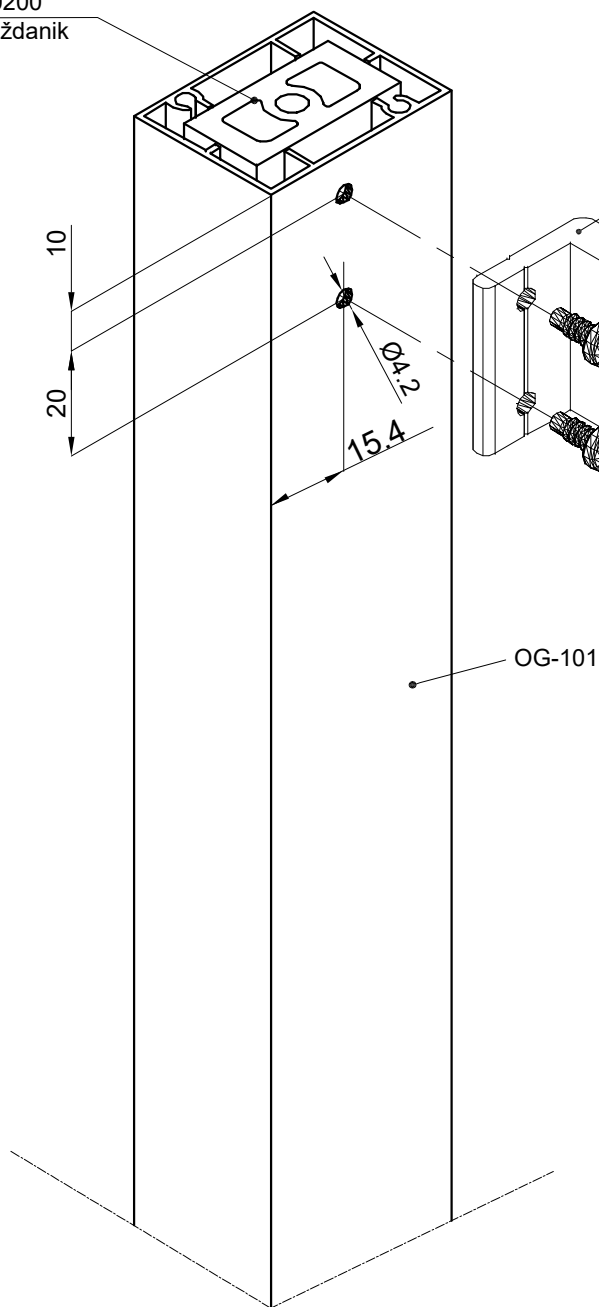

521.047 za(F-0174)  
1 vijak 4.8x16 DIN7982  
2 vijka 4.8x22 DIN7981

(F-0174-prečka pod rukohvatom),  
spaja se preko veznika (521.047)  
za al stub (OG101)

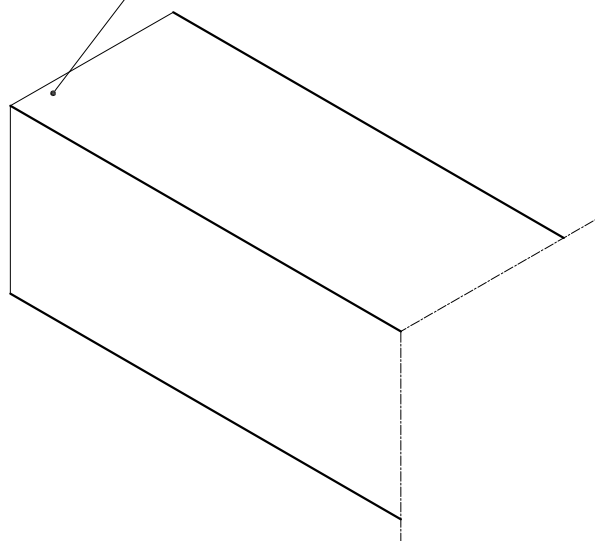

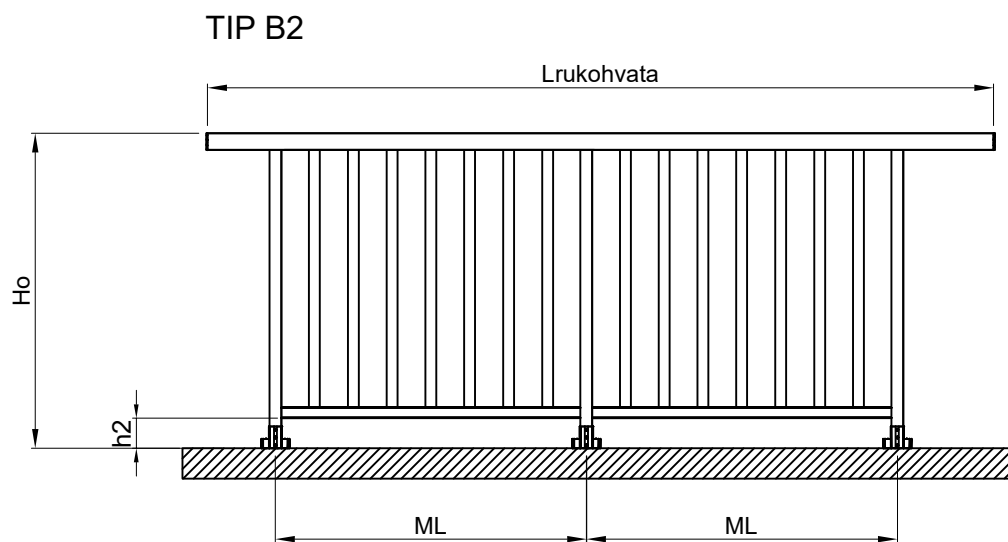
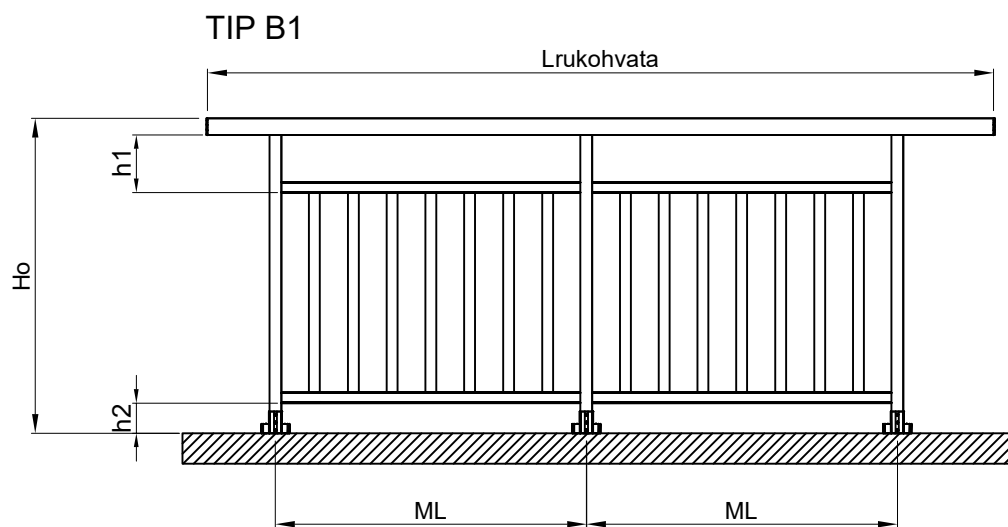



373.007 PVC  
čep za rukohvat  
F-0689

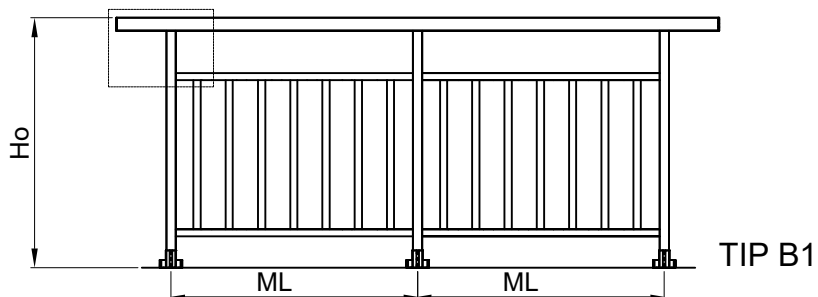
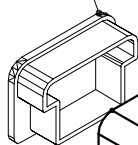

2 vijka 4.8x19 DIN7981  
1 Vijak M8x30 DIN 933  
za spajanje (F-0620)  
podrukohvata sa  
al. stubom (F-1246)

F-0620  
podrukohvat

F-0200  
Moždanik

F-1246  
Al Stub

521.052  
2 vijaka 4.8x19 DIN7981  
2 vijka M 6x8 DIN914  
Veznik za spajanje F-0620  
sa al. stubom F-1246

Vijci 4.8x19 DIN7981  
za spajanje (F-0620) sa  
(OG-111)

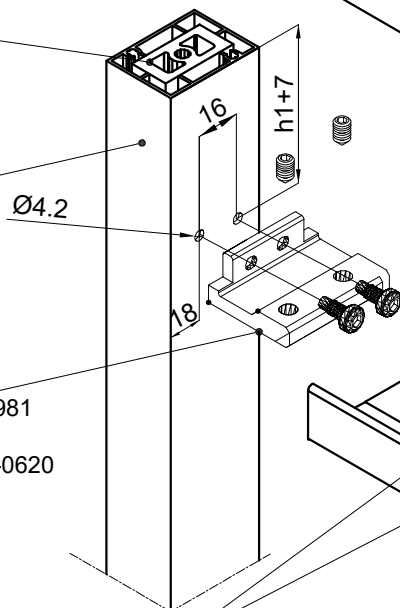

F-0689  
(rukohvat)

OG-103

F-0620

OG-111

OG-111

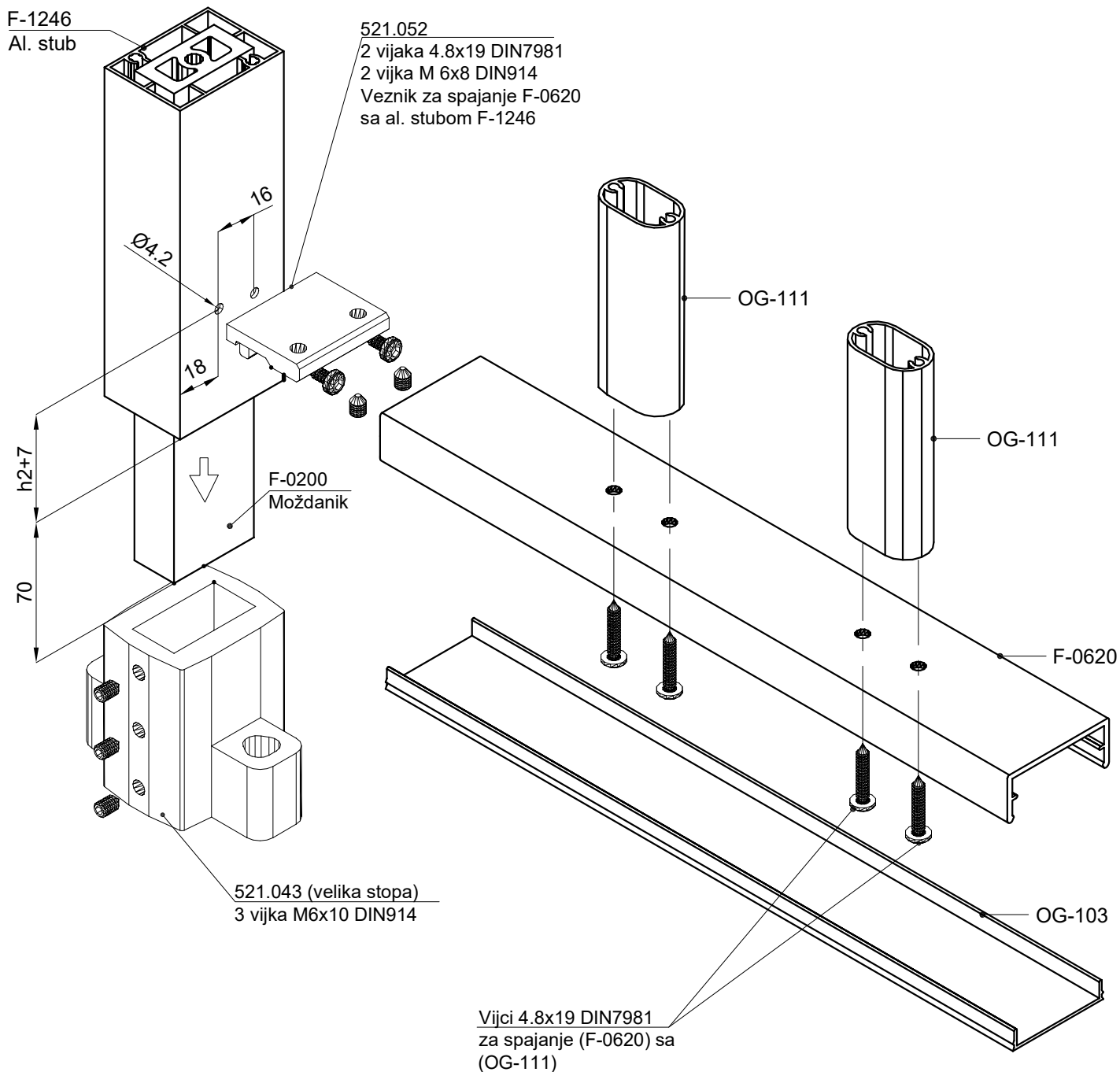
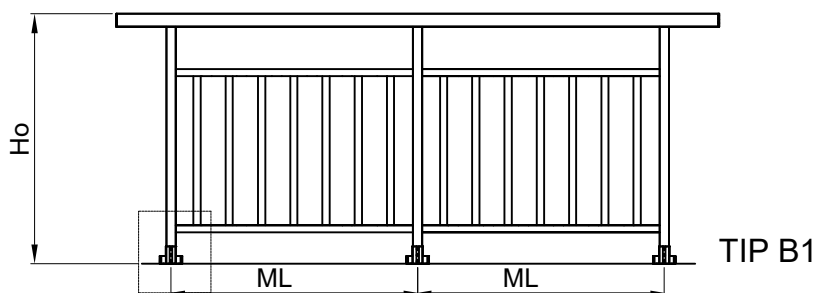

373.007 PVC  
čep za rukohvat  
F-0689

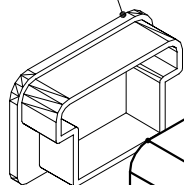

F-0689  
(rukohvat)

2 vijka 4.8x19 DIN7981  
1 Vijak M8x30 DIN 933  
za spajanje (F-0620)  
podrukohvata sa  
al. stubom (F-1246)

F-0620  
podrukohvat

F-0200  
Moždanik

F-1246  
Al. stub

Vijci 4.8x19 DIN7981  
za spajanje (F-0620)  
podrukohvata  
sa (OG-111)

OG-111

OG-111

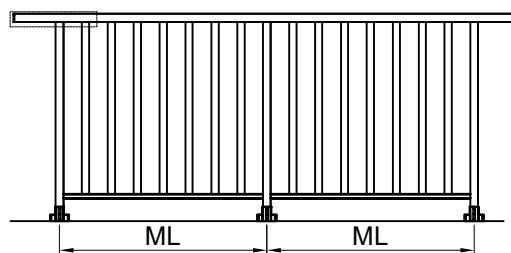

TIP B2

373.007 PVC  
čep za rukohvat  
F-0689

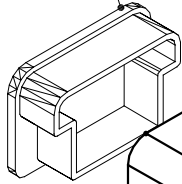

F-0689  
(rukohvat)

2 vijka 4.8x19 DIN7981  
1 Vijak M8x30 DIN 933  
za spajanje (F-0620)  
podrukohvata sa  
al. stubom (F-1246)

F-0620  
podrukohvat

F-0200  
Moždanik

F-1246  
Al. stub

F-1541  
Ispuna

F-1451  
Ispuna

Vijci 4.2x13 DIN7981  
za spajanje (F-0620)  
podrukohvata  
sa (F-1451)

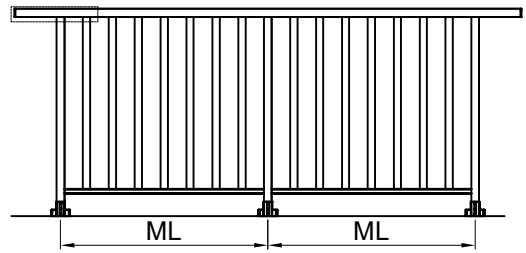

TIP B2

373.007 PVC  
čep za rukohvat  
F-0689

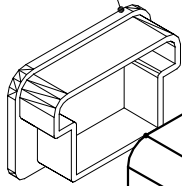

F-0689  
(rukohvat)

2 vijka 4.8x19 DIN7981  
1 Vijak M8x30 DIN 933  
za spajanje (F-0620)  
podrukohvata sa  
al. stubom (F-1246)

F-0620  
podrukohvat

F-0200  
Moždanik

F-1246  
Al. stub

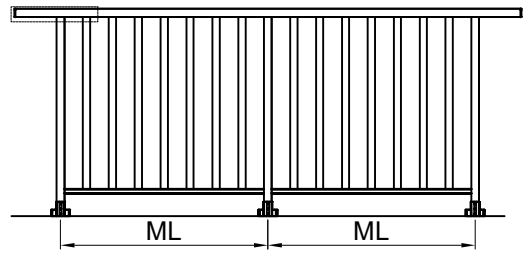

TIP B2

Vijci 4.2x13 DIN7981  
za spajanje (F-0620)  
podrukohvata  
sa (F-1451)

F-1541  
Ispuna

F-1451  
Ispuna

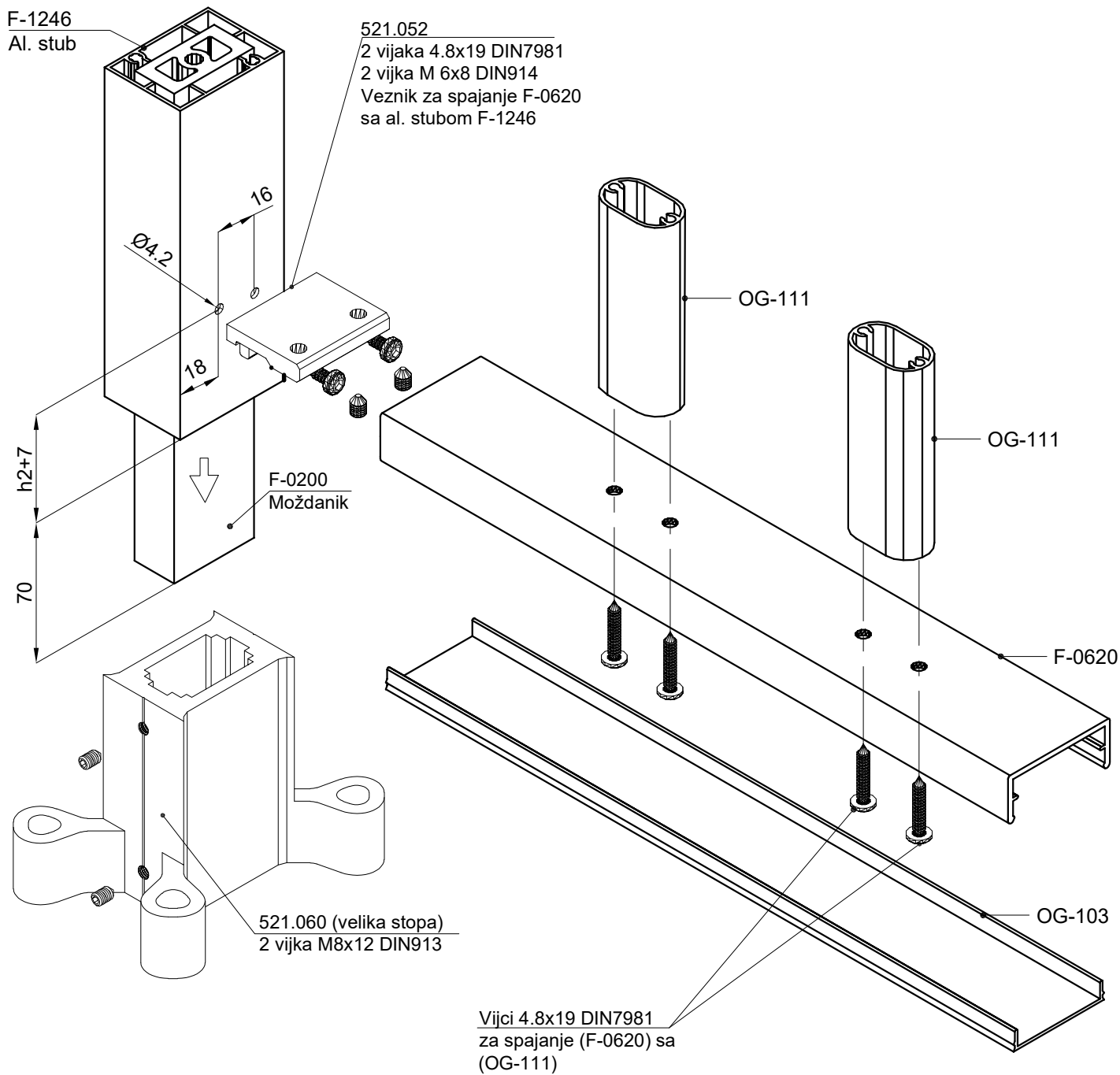
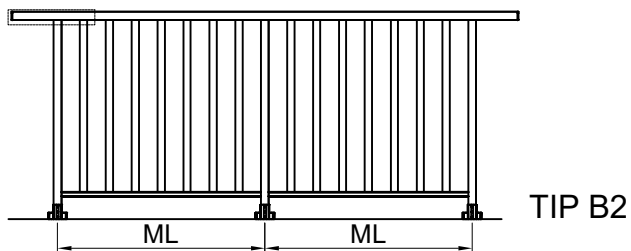

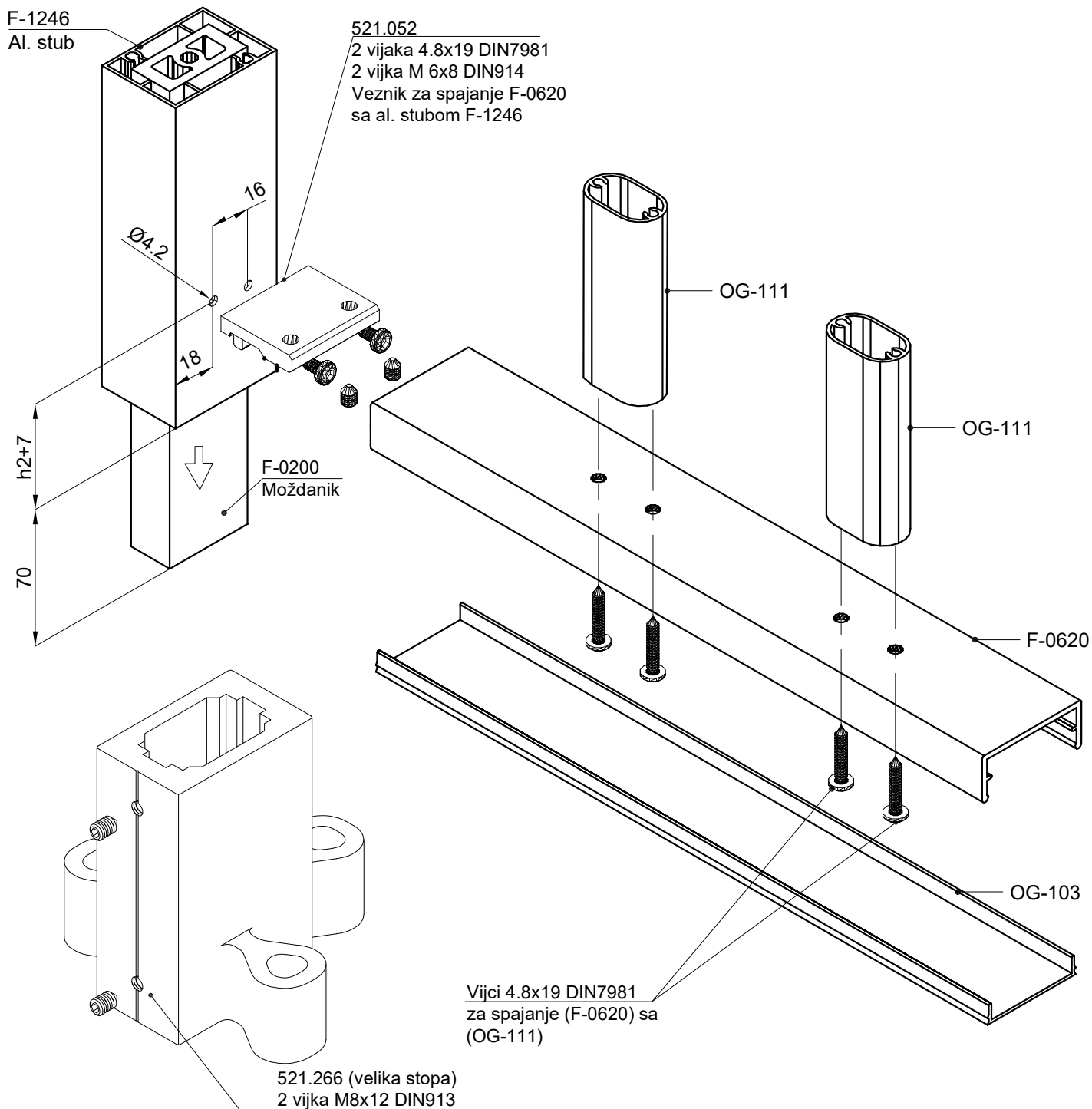
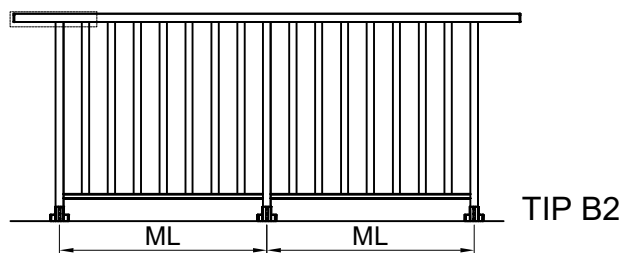



Držač stakla 521.082 /za staklo 55.2

TIP C1

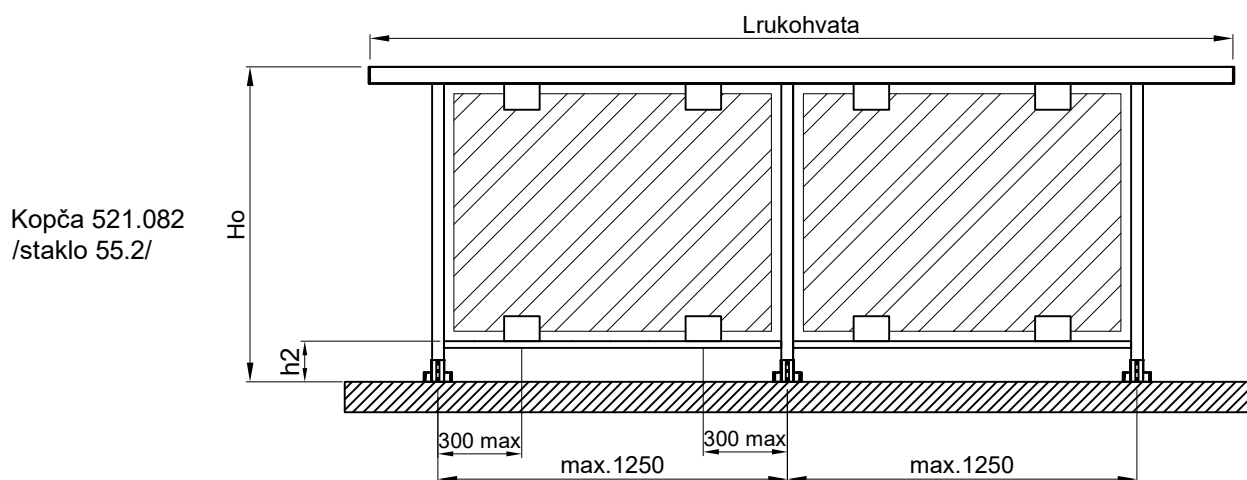

TIP C2

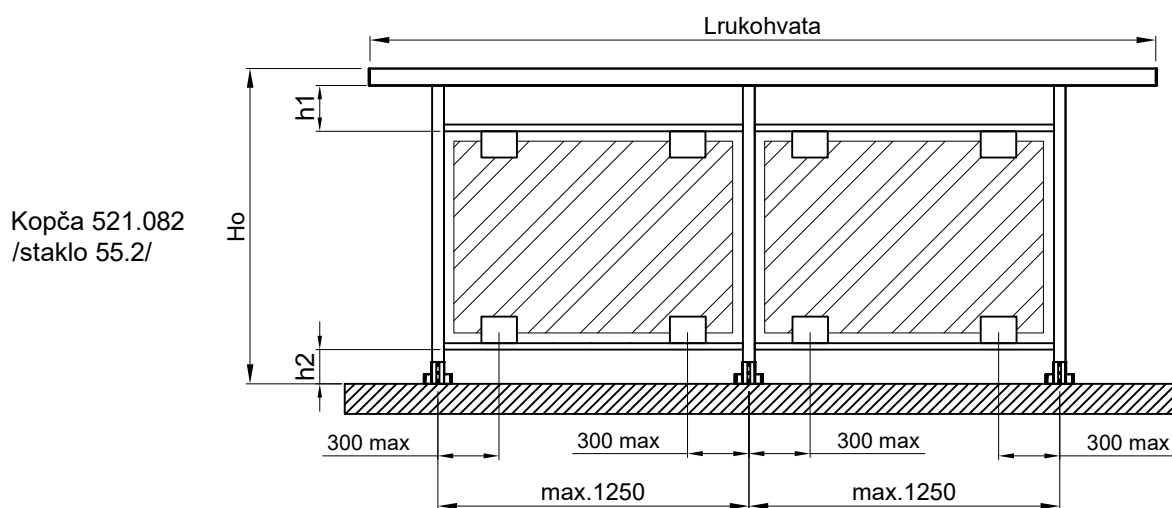

TIP C3

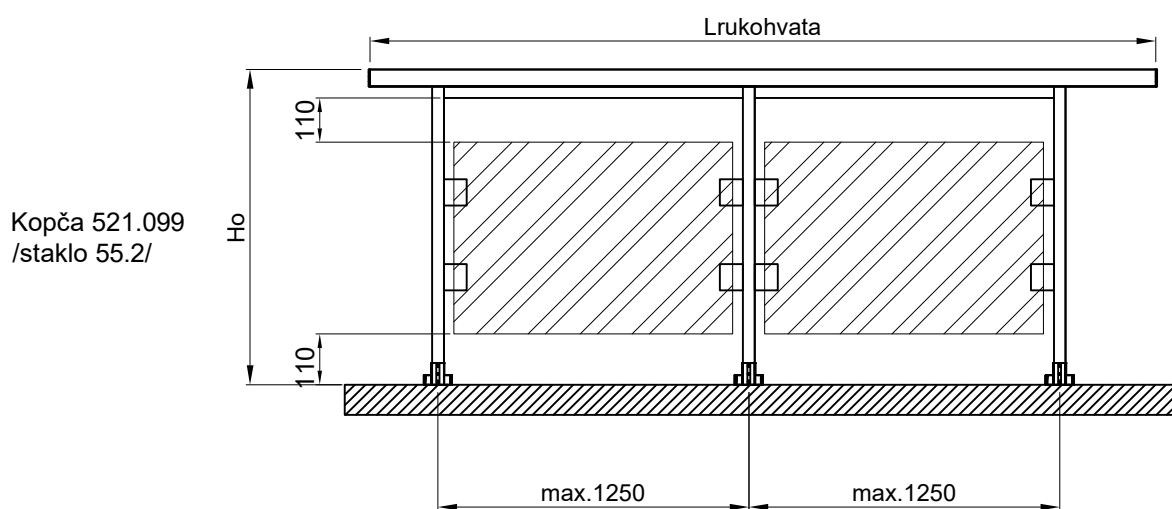

Držač stakla 521.082 /za staklo 55.2

TIP C4

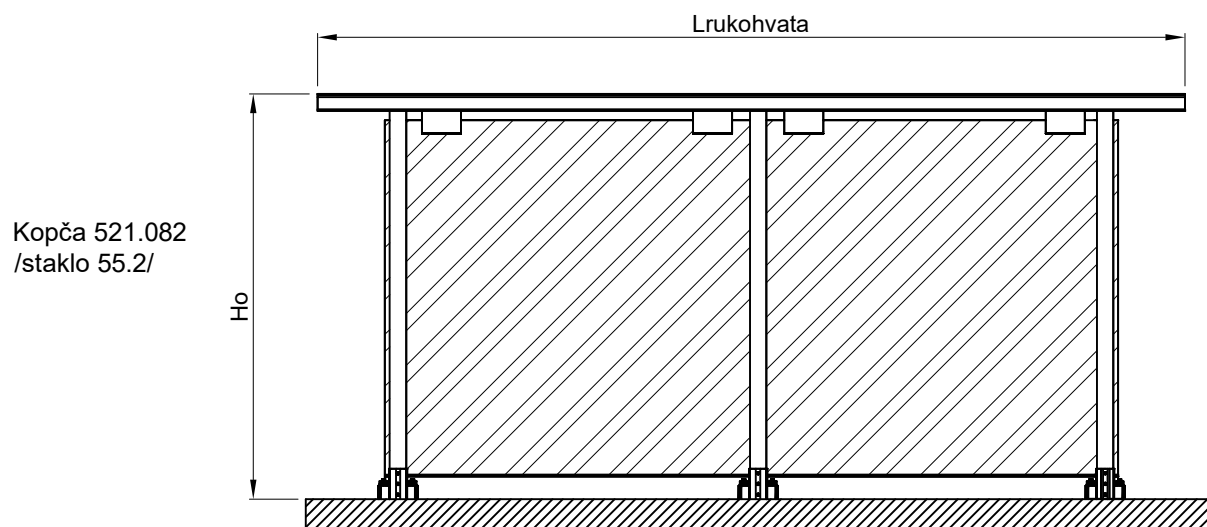

Staklena ograda sa kontinuiranom vodilicom (staklo 55.2)

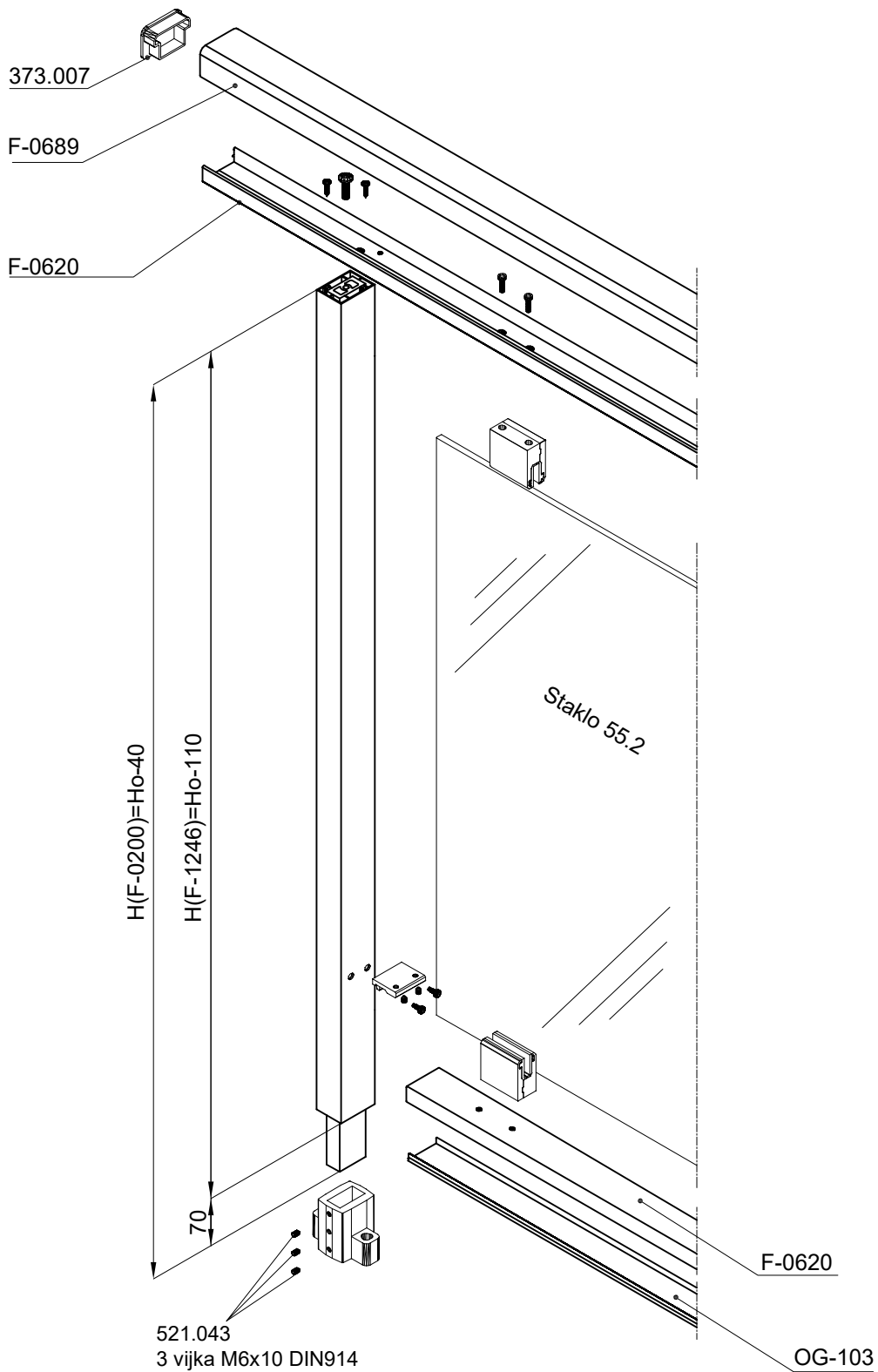
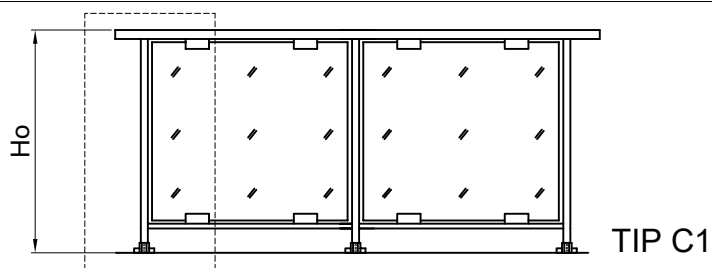

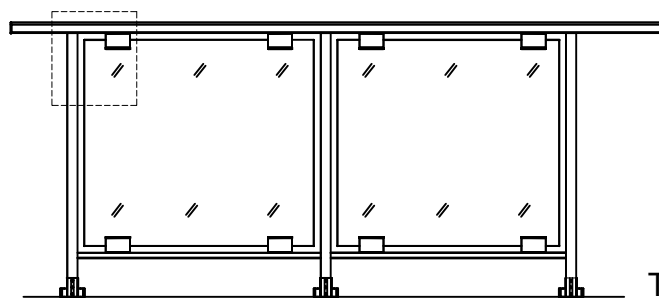

TIP C1

373.007 PVC  
čep za rukohvat  
F-0689

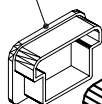

F-0689  
Rukohvat

F-0620  
Podrukohvat

2 vijka 4.8x19 DIN7981  
1 Vijak M8x30 DIN 933  
za spajanje (F-0620)  
podrukohvata sa  
al. stubom (F-1246)

Držač stakla ravni; 521.082  
koristi se za staklo 55.2  
2 vijka M6x20 DIN 6912  
2 vijka M5x20 DIN 7991

Vijci M6x20 DIN6912  
Za spajanje F-620 sa  
držačem stakla 521.045

F-1246  
Al. stub

Staklo 55.2

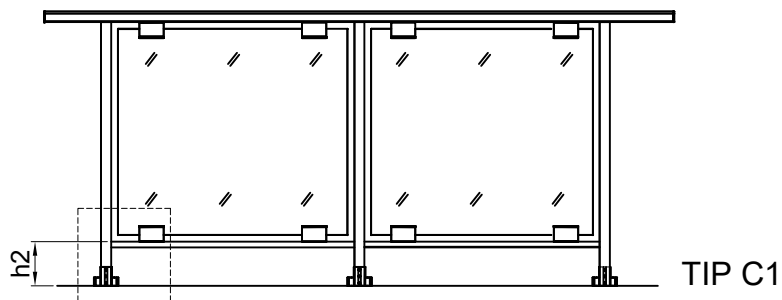

F-1246

521.052  
 2 vijaka 4.8x19 DIN7981  
 2 vijka M 6x8 DIN914  
 Veznik za spajanje F-0620  
 sa al. stubom F-1246

Staklo 55.2

Držač stakla ravni; 521.082  
 koristi se za staklo 55.2  
 2 vijka M6x20 DIN 6912  
 2 vijka M5x20 DIN 7991

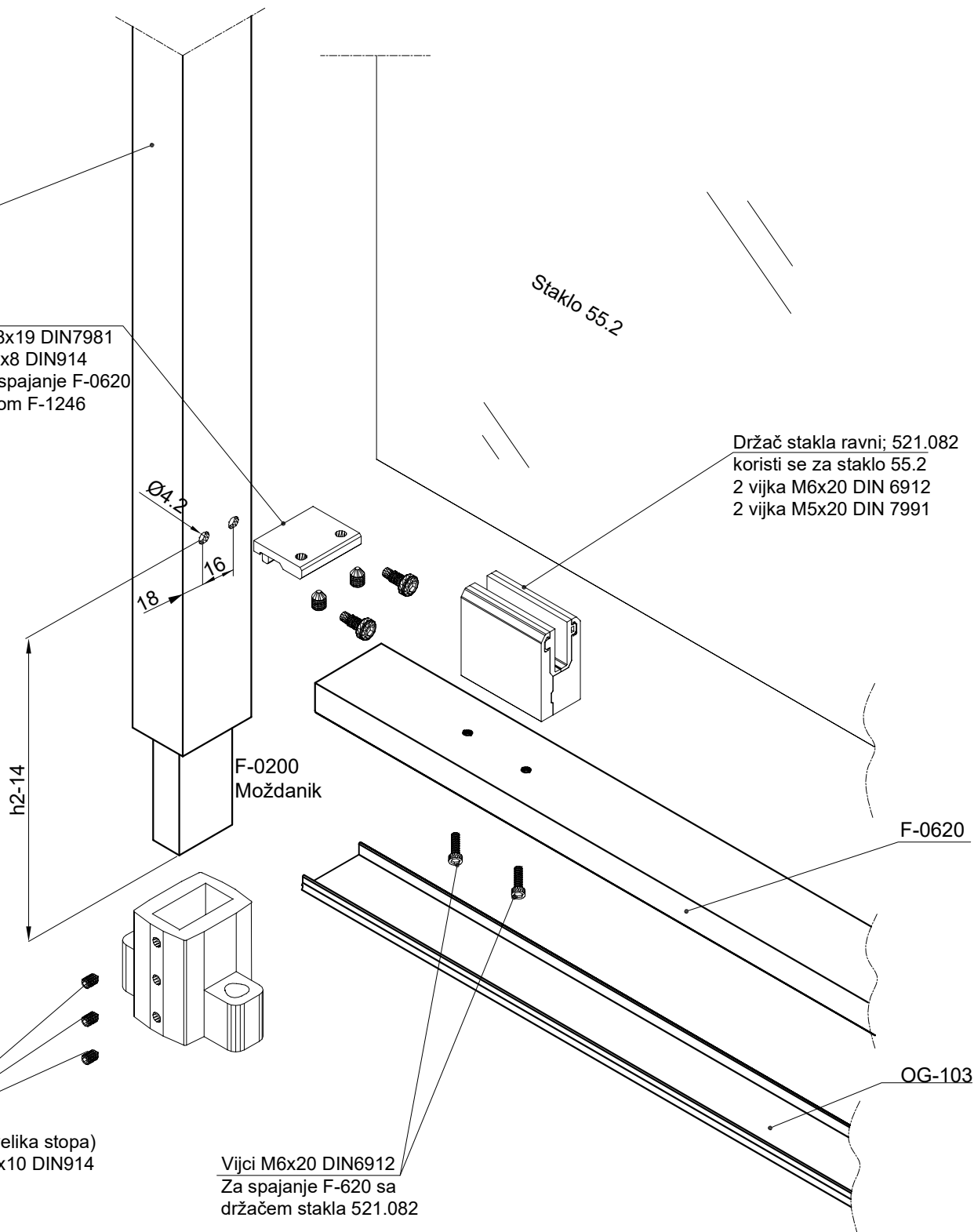

521.043 (velika stopa)  
 3 vijka M6x10 DIN914

Vijci M6x20 DIN6912  
 Za spajanje F-620 sa  
 držačem stakla 521.082

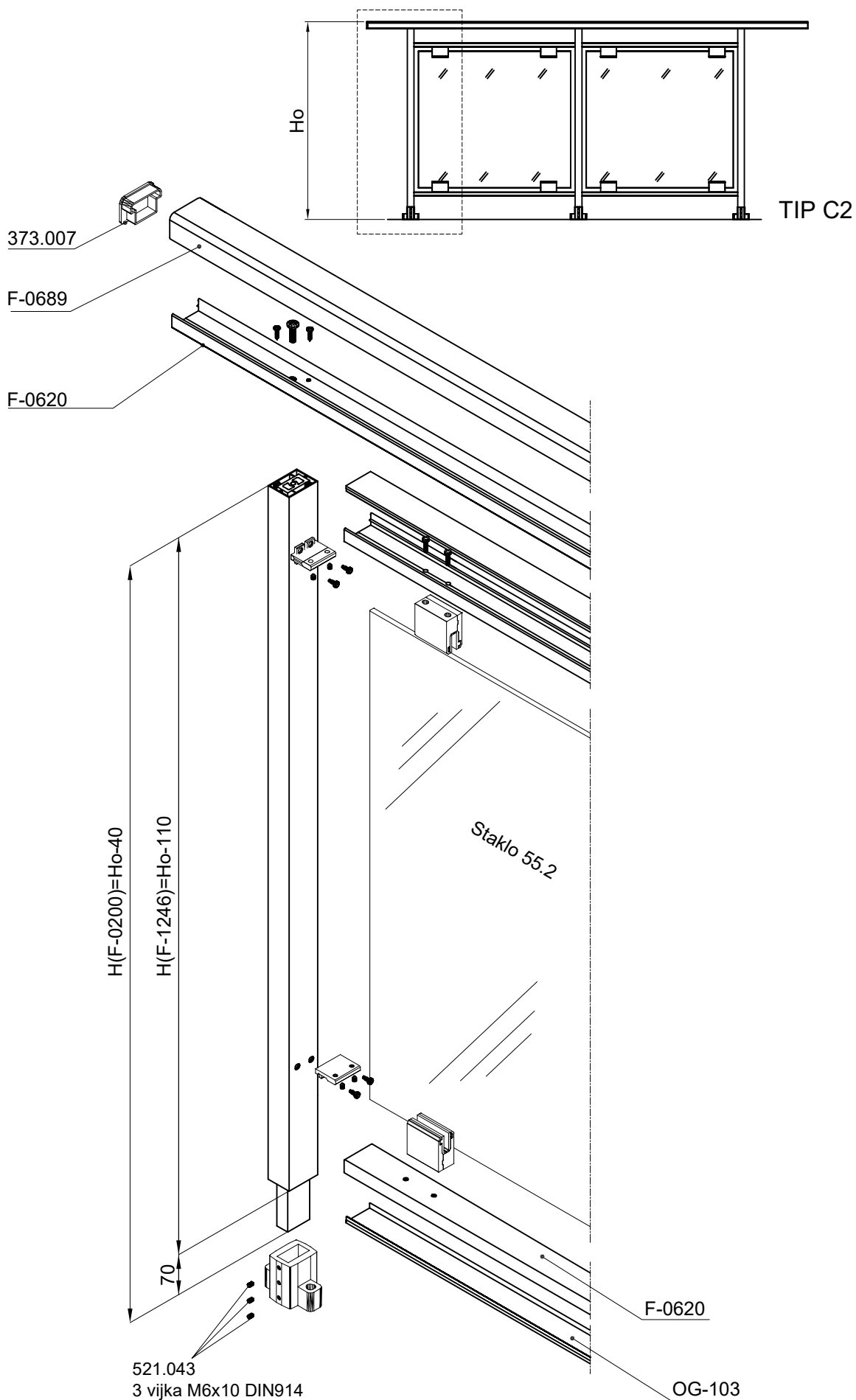

373.007 PVC  
čep za rukohvat  
F-0689

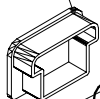

F-0689  
Rukohvat

F-0620  
podrukohvat

2 vijka 4.8x19 DIN7981  
1 Vijak M8x30 DIN 933  
za spajanje (F-0620)  
podrukohvata sa  
al. stubom (F-1246)

521.052  
2 vijaka 4.8x19 DIN7981  
2 vijka M 6x8 DIN914  
Veznik za spajanje F-0620  
sa al. stubom F-1246

Vijci M6x20 DIN6912  
Za spajanje F-620 sa  
držačem stakla 521.082

Držač stakla ravni; 521.082  
koristi se za staklo 55.2  
2 vijka M6x20 DIN 6912  
2 vijka M5x20 DIN 7991

F-1246  
Al. stub

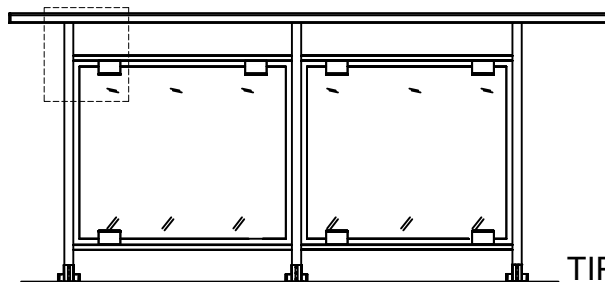

TIP C2

OG-10;

F-0620

Staklo 55.2

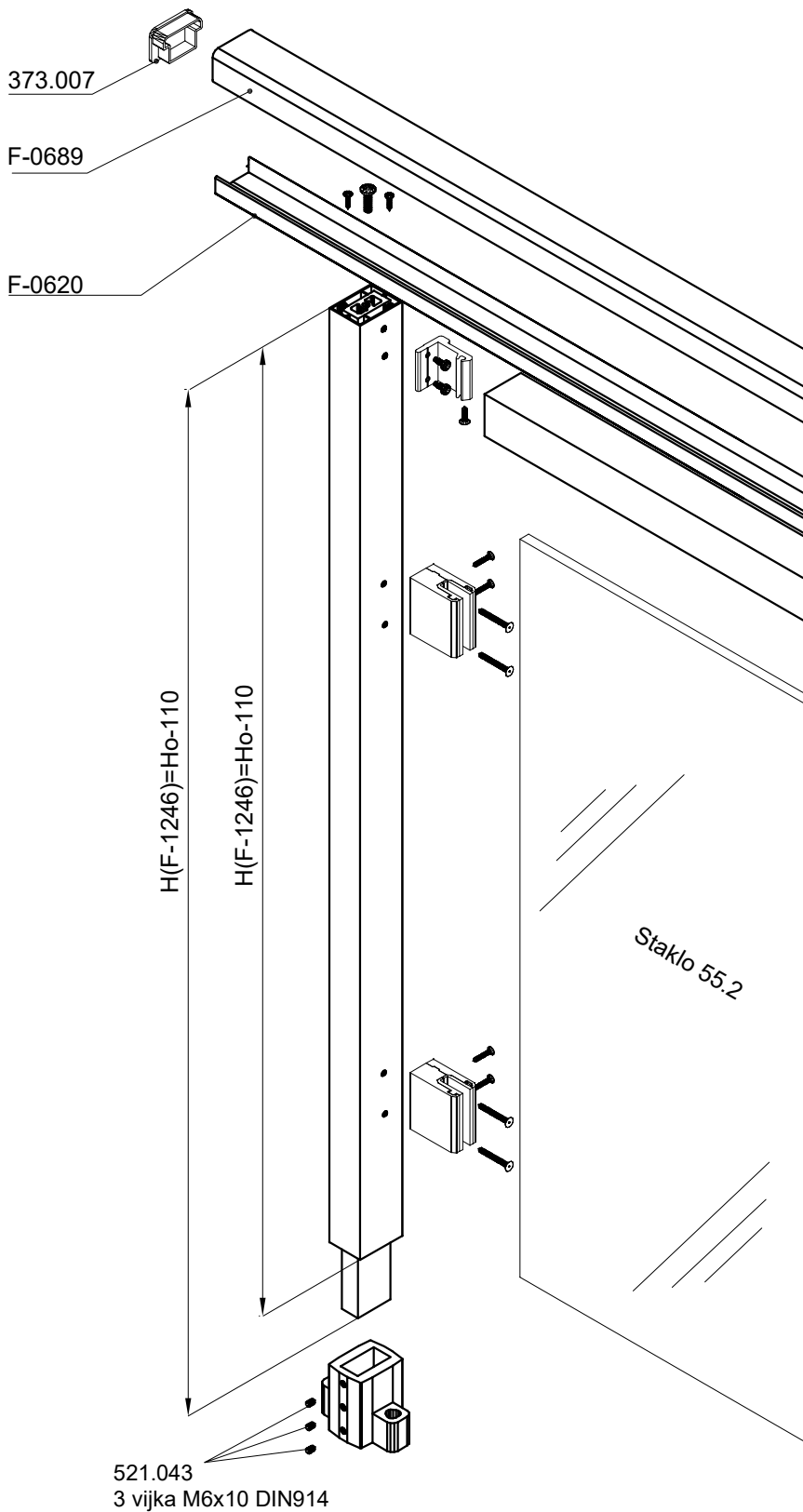
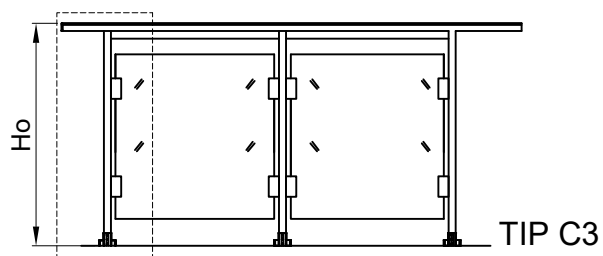

373.007 PVC  
čep za rukohvat  
F-0689

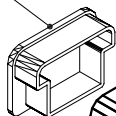

2 vijka 4.8x19 DIN7981  
1 Vijak M8x30 DIN 933  
za spajanje (F-0620)  
podrukohvata sa  
al. stubom (F-1246)

521.047 za(F-0174)  
1 vijak 4.8x16 DIN7982  
2 vijka 4.8x22 DIN7981

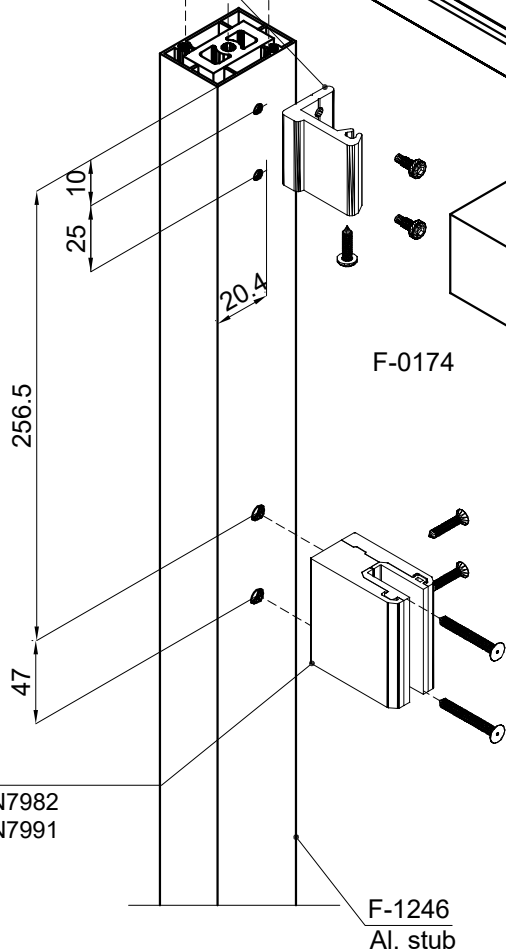

521.099  
2 vijak 4.8x38 DIN7982  
2 vijka M5x20 DIN7991

F-1246  
Al. stub

Staklo 55.2

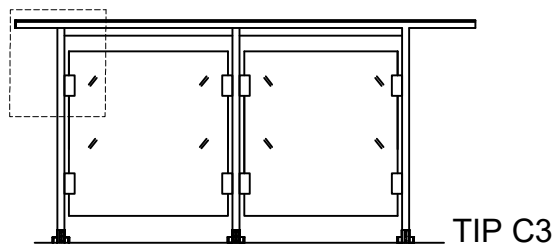

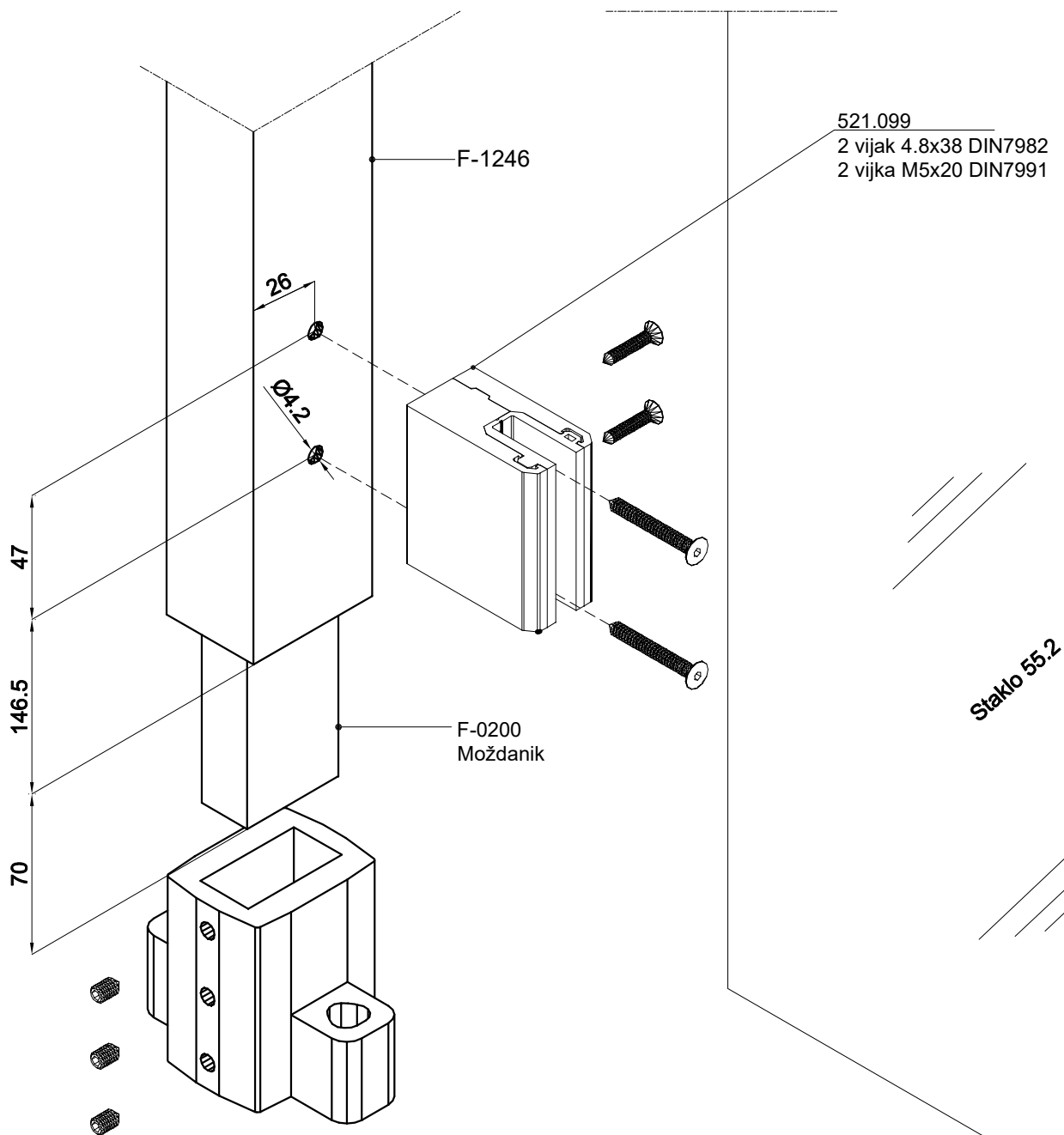
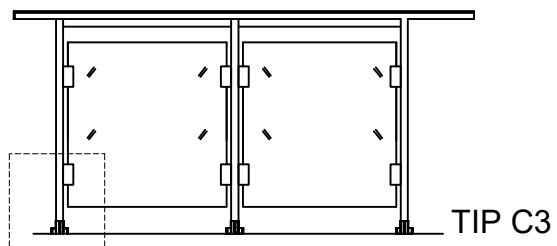

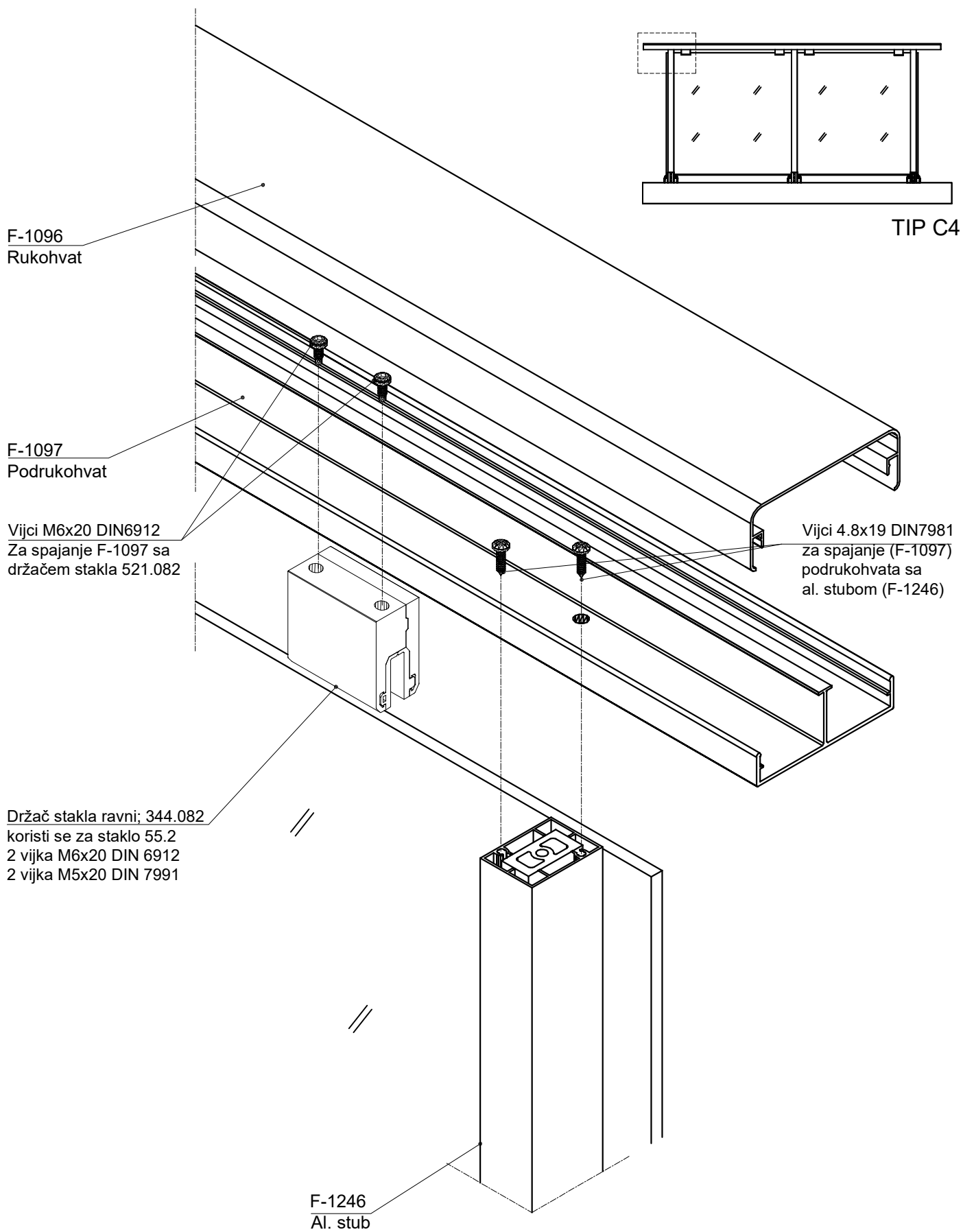

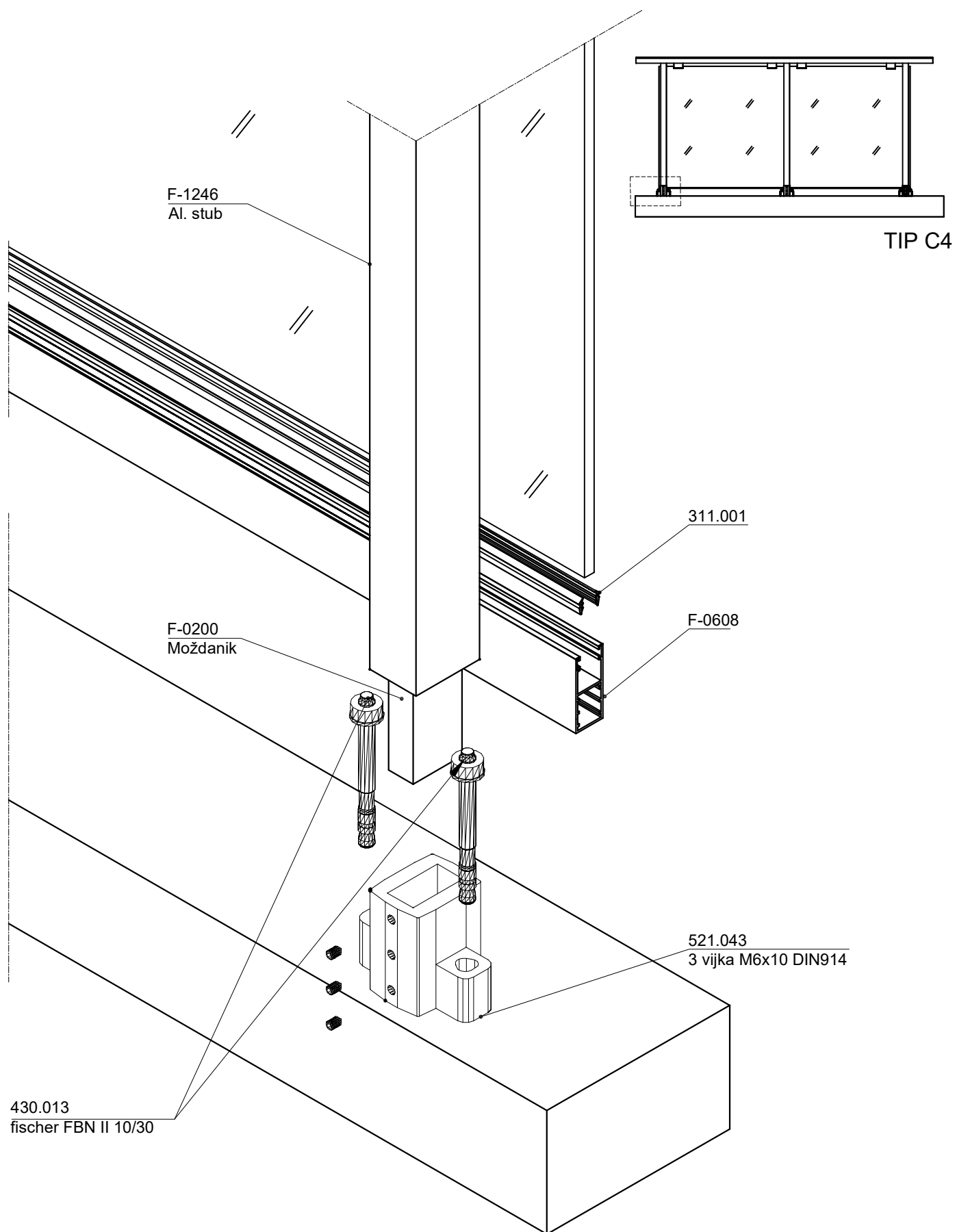

Držač stakla 521.045 /za staklo 44.2

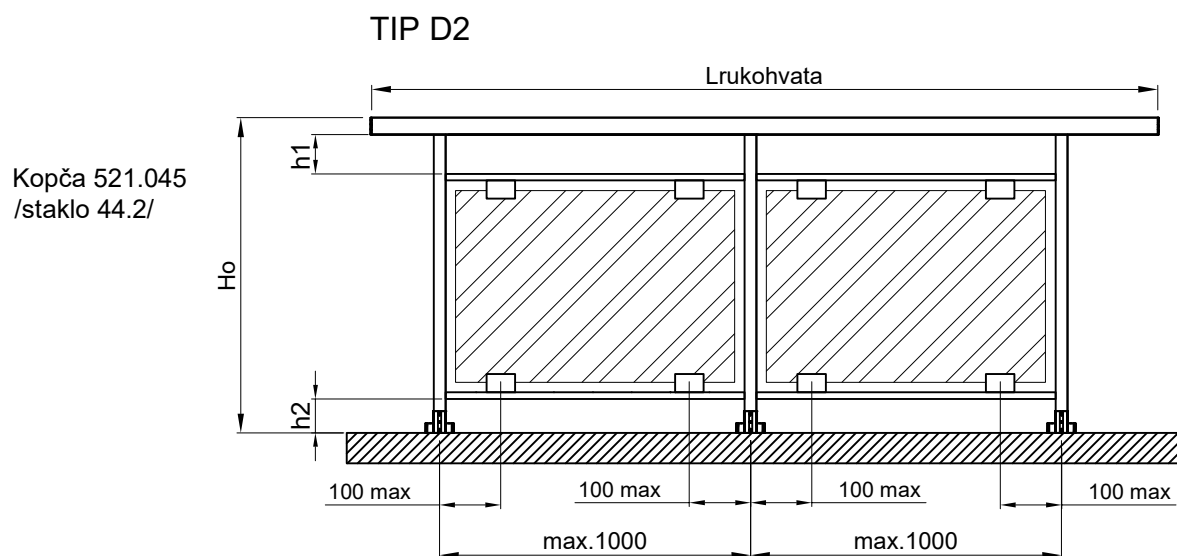
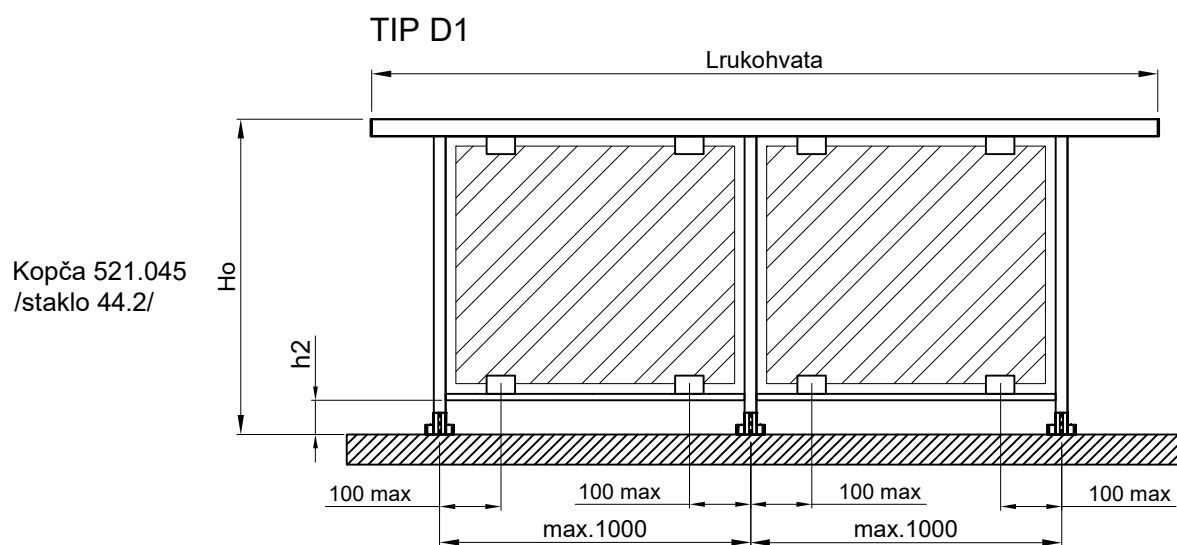



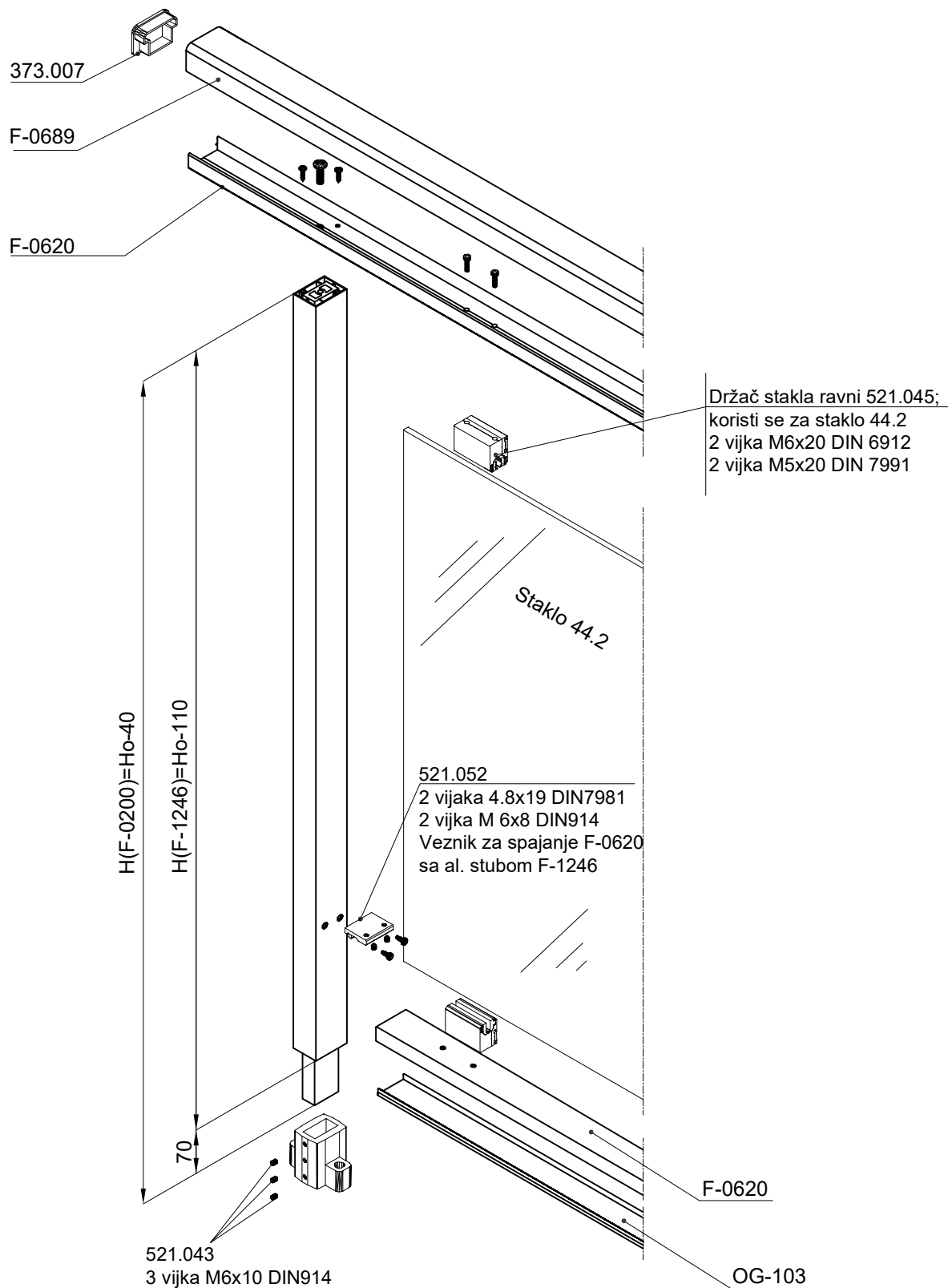
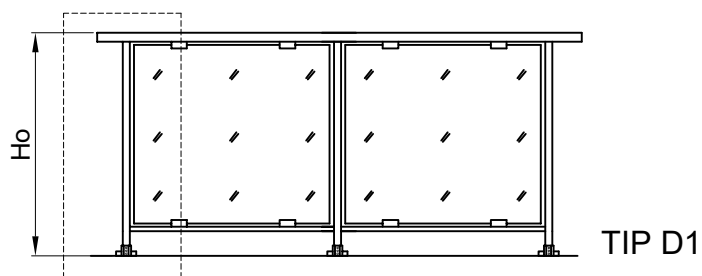

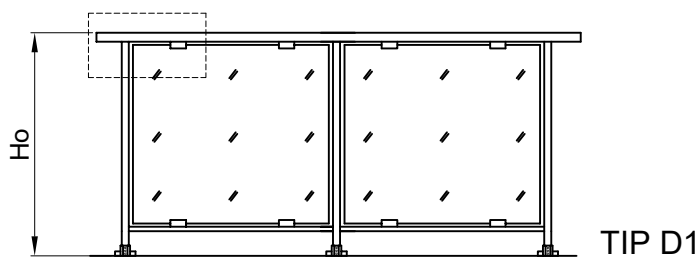

373.007 PVC  
čep za rukohvat  
F-0689

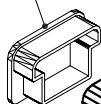

F-0689  
Rukohvat

F-0620  
Podrukohvat

2 vijka 4.8x19 DIN7981  
1 Vijak M8x30 DIN 933  
za spajanje (F-0620)  
podrukohvata sa  
al. stubom (F-1246)

Držač stakla ravni 521.045  
koristi se za staklo 44.2  
2 vijka M6x20 DIN 6912  
2 vijka M5x20 DIN 7991

Vijci M6x20 DIN6912  
Za spajanje F-620 sa  
držačem stakla 521.045

F-1246  
Al. stub

Staklo 44.2

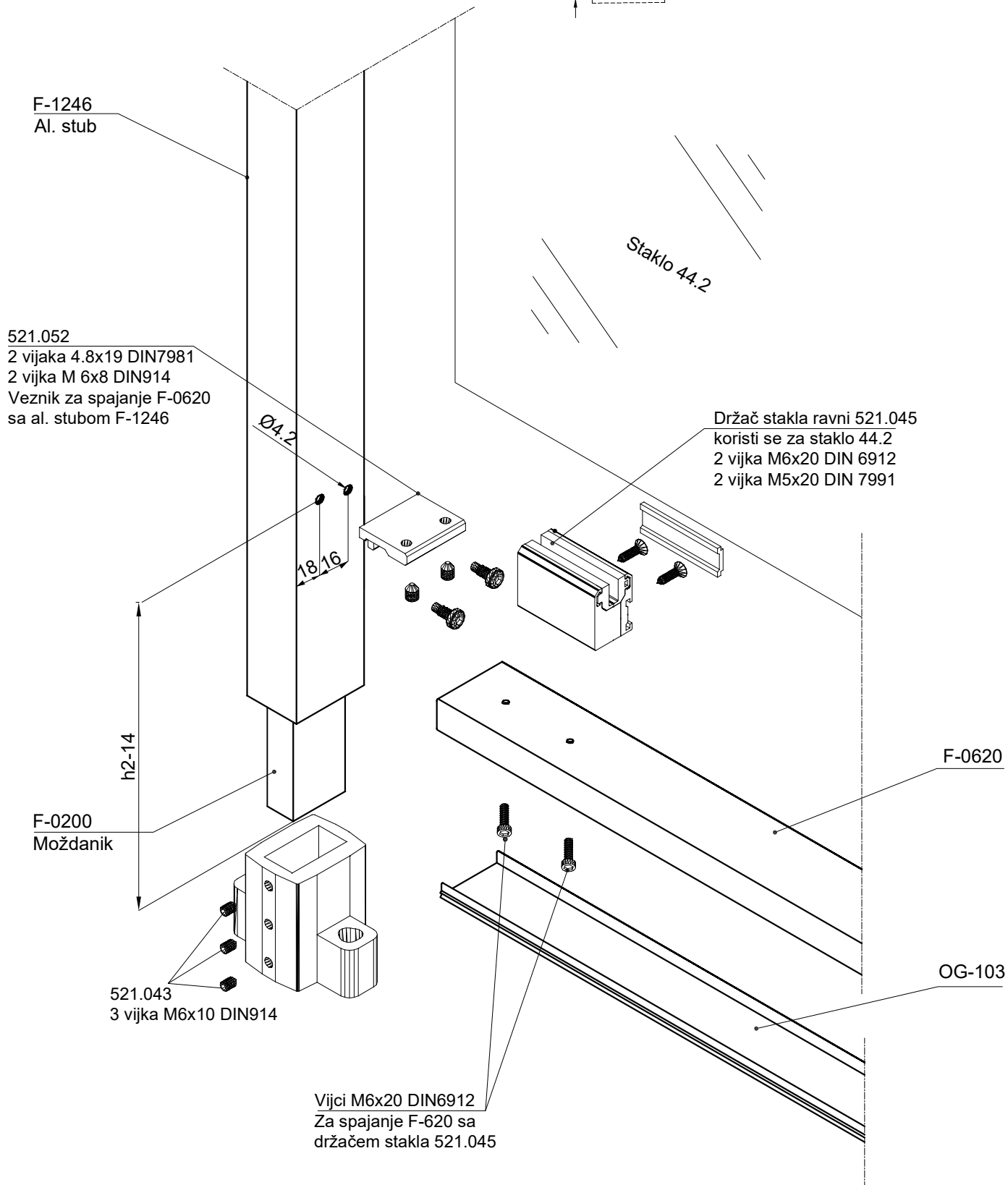
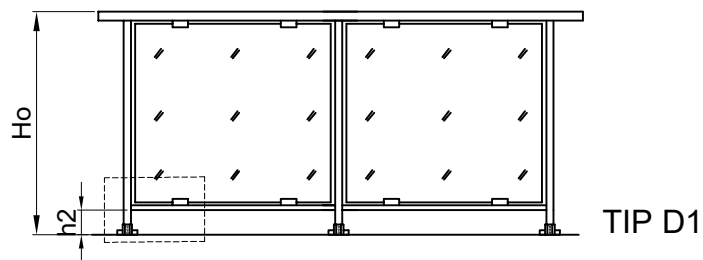

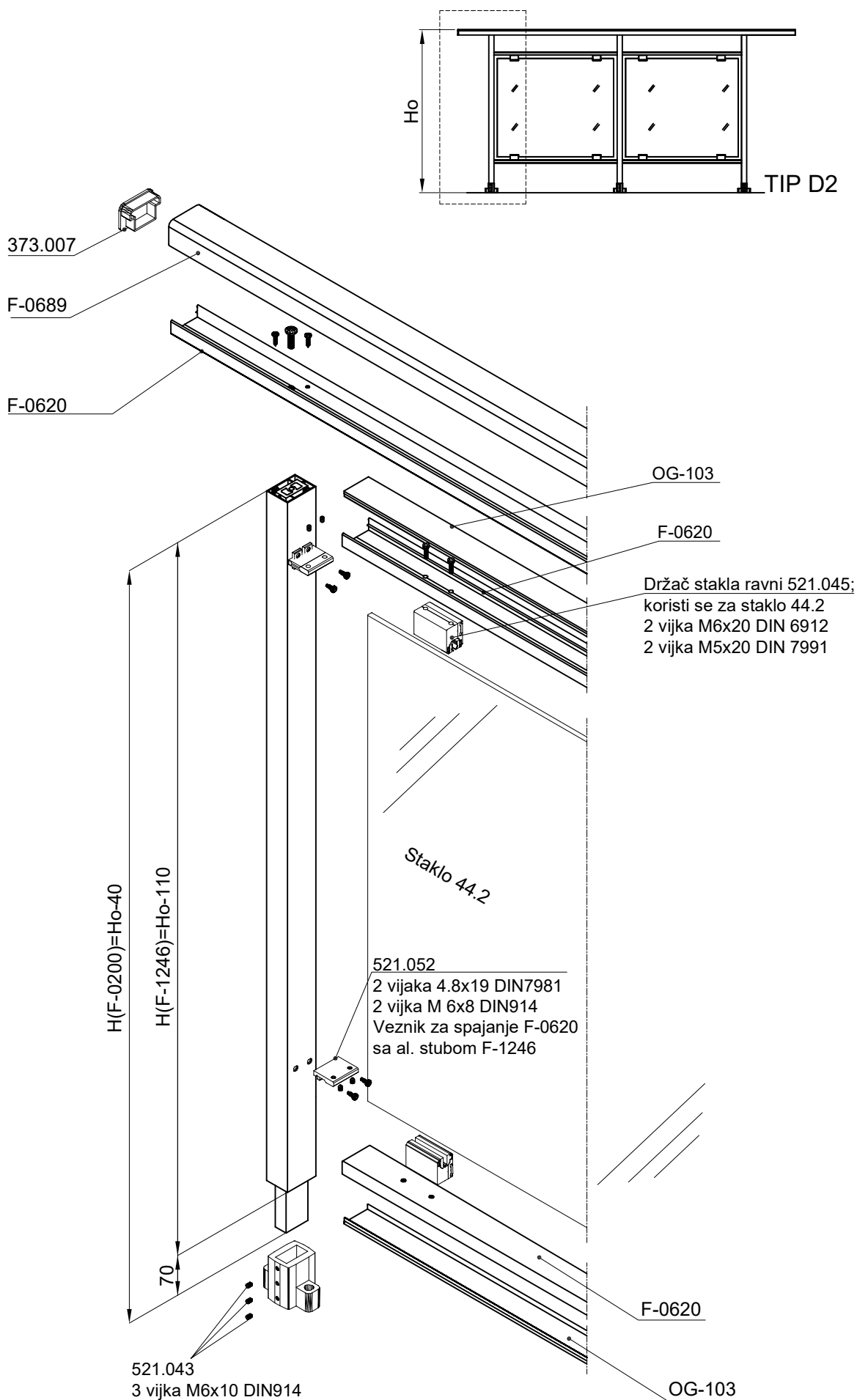

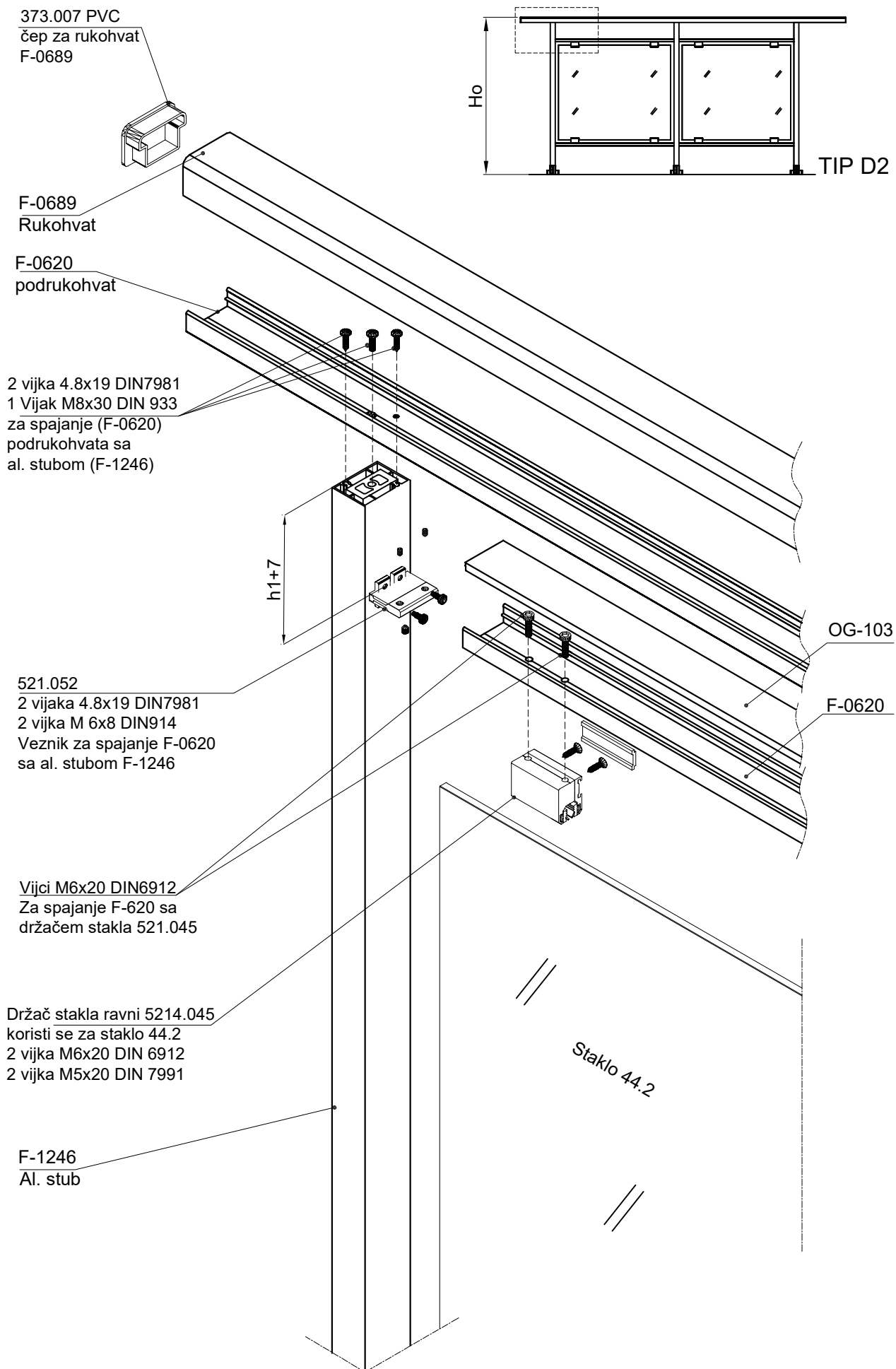

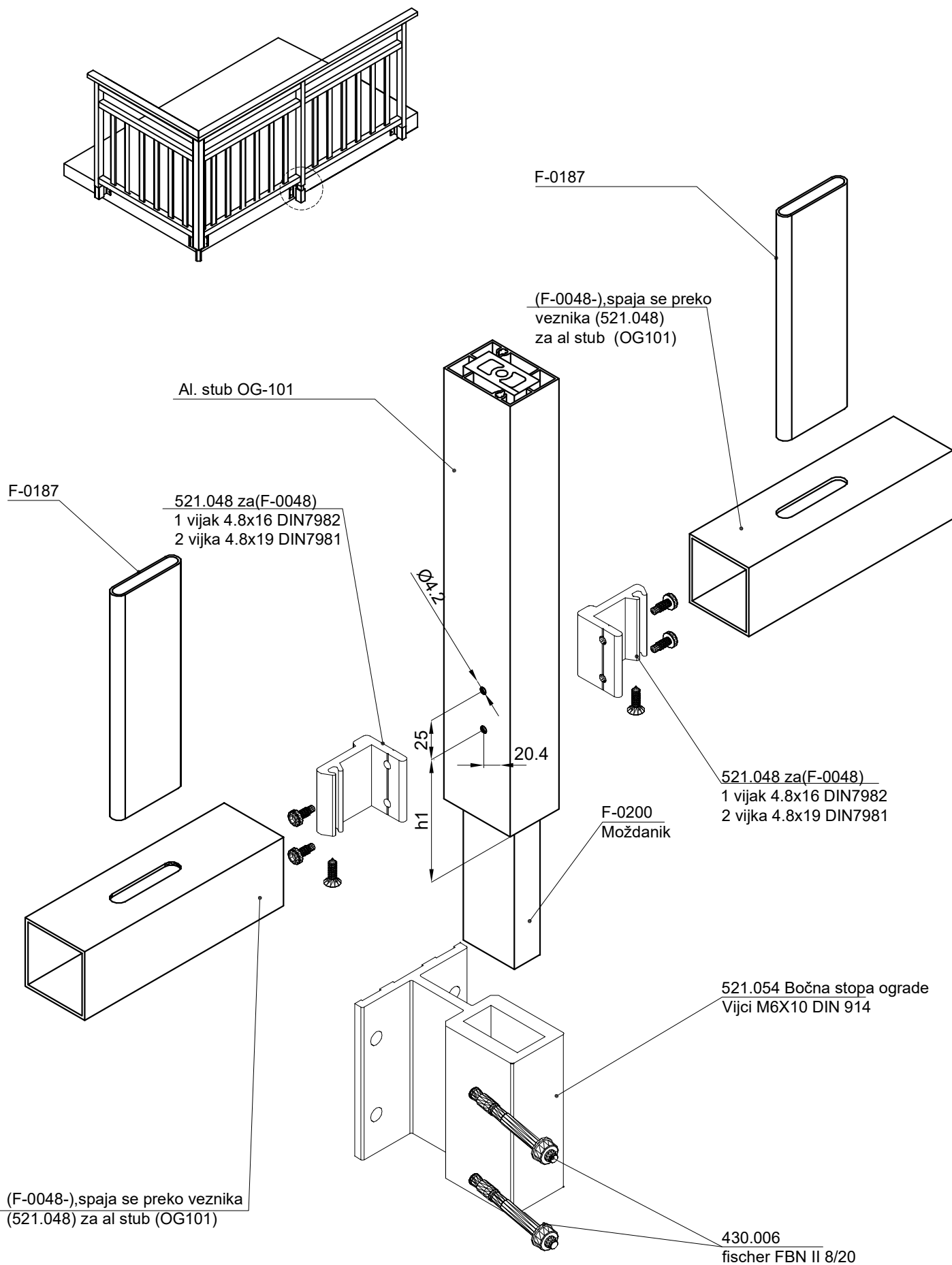

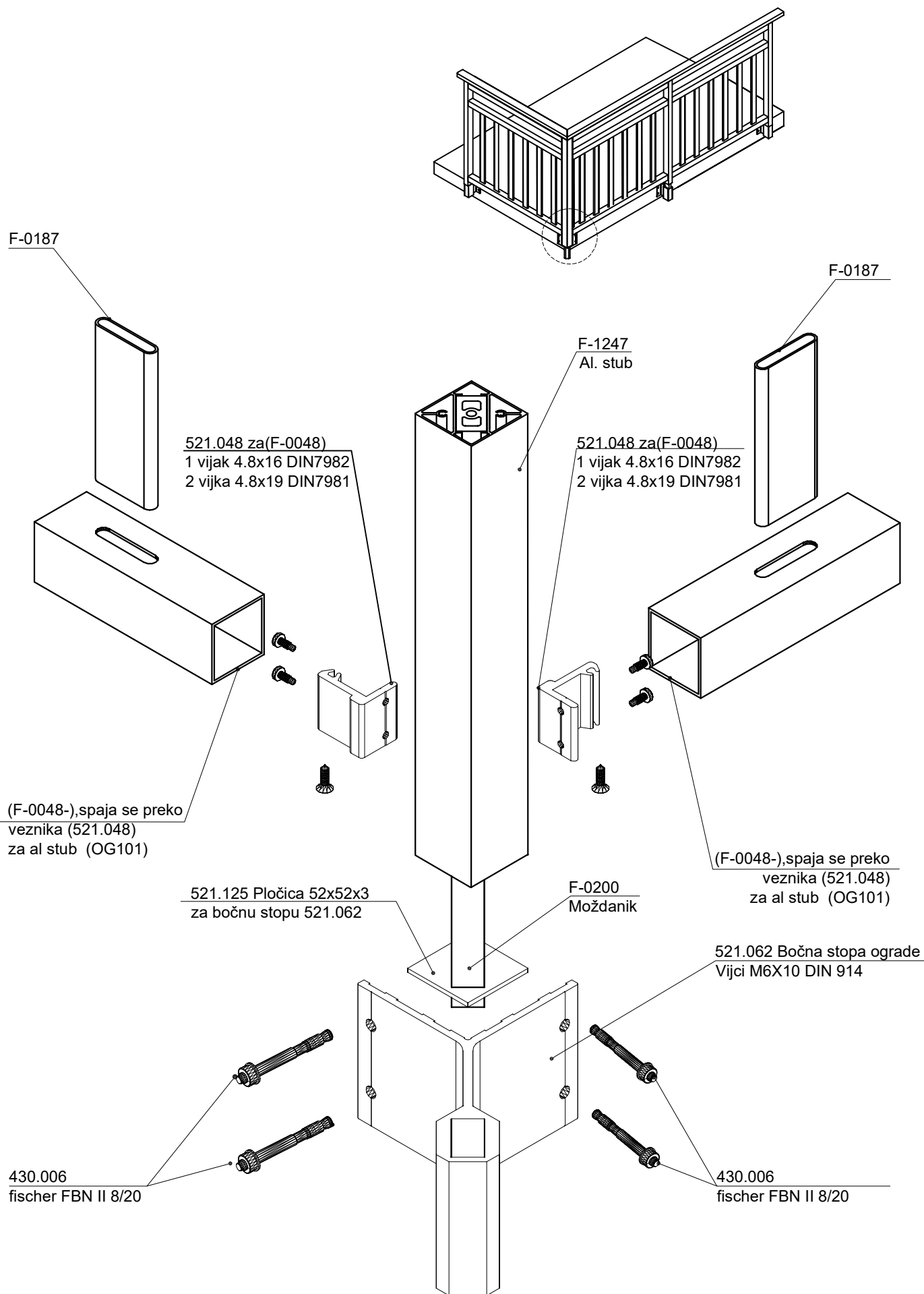

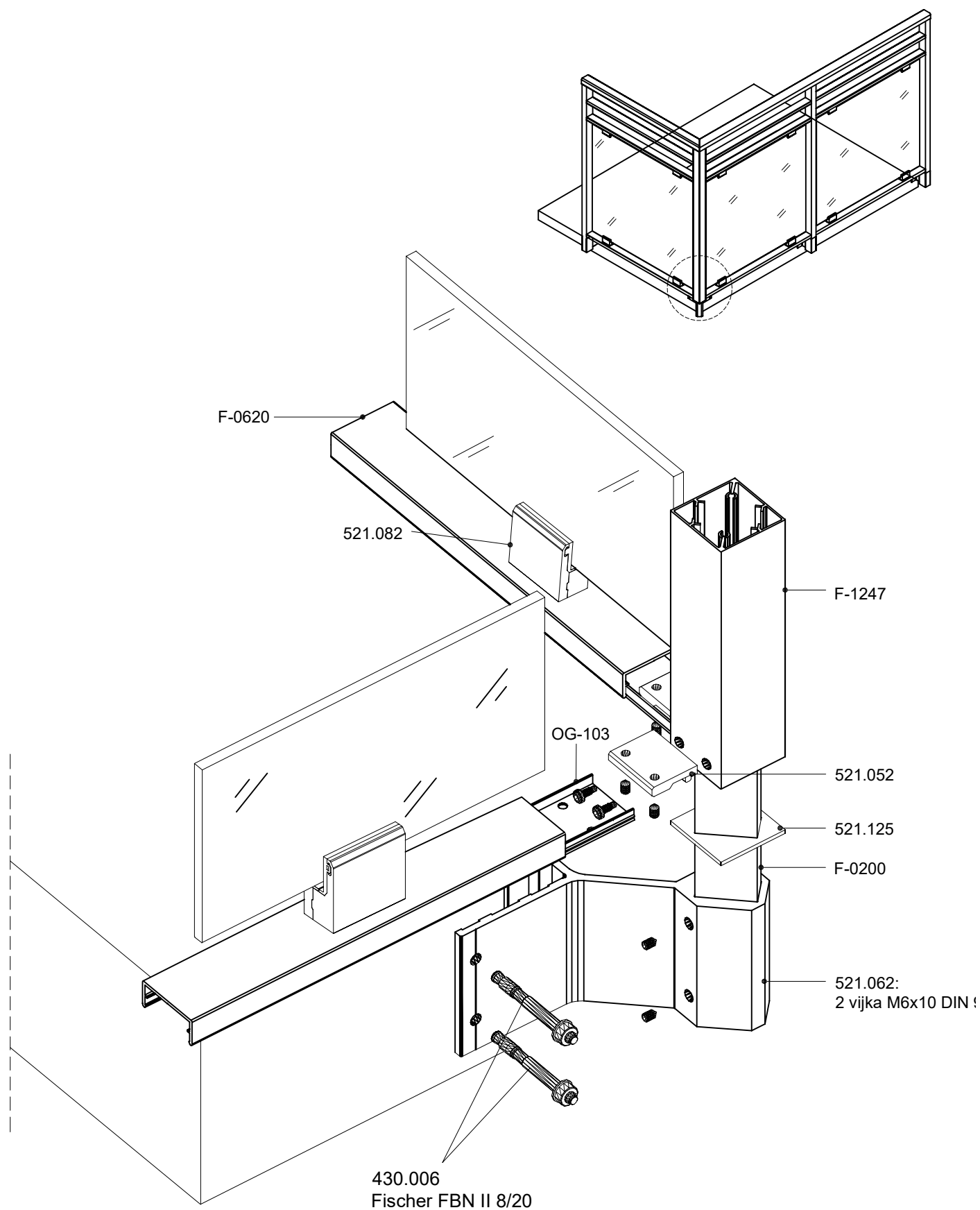

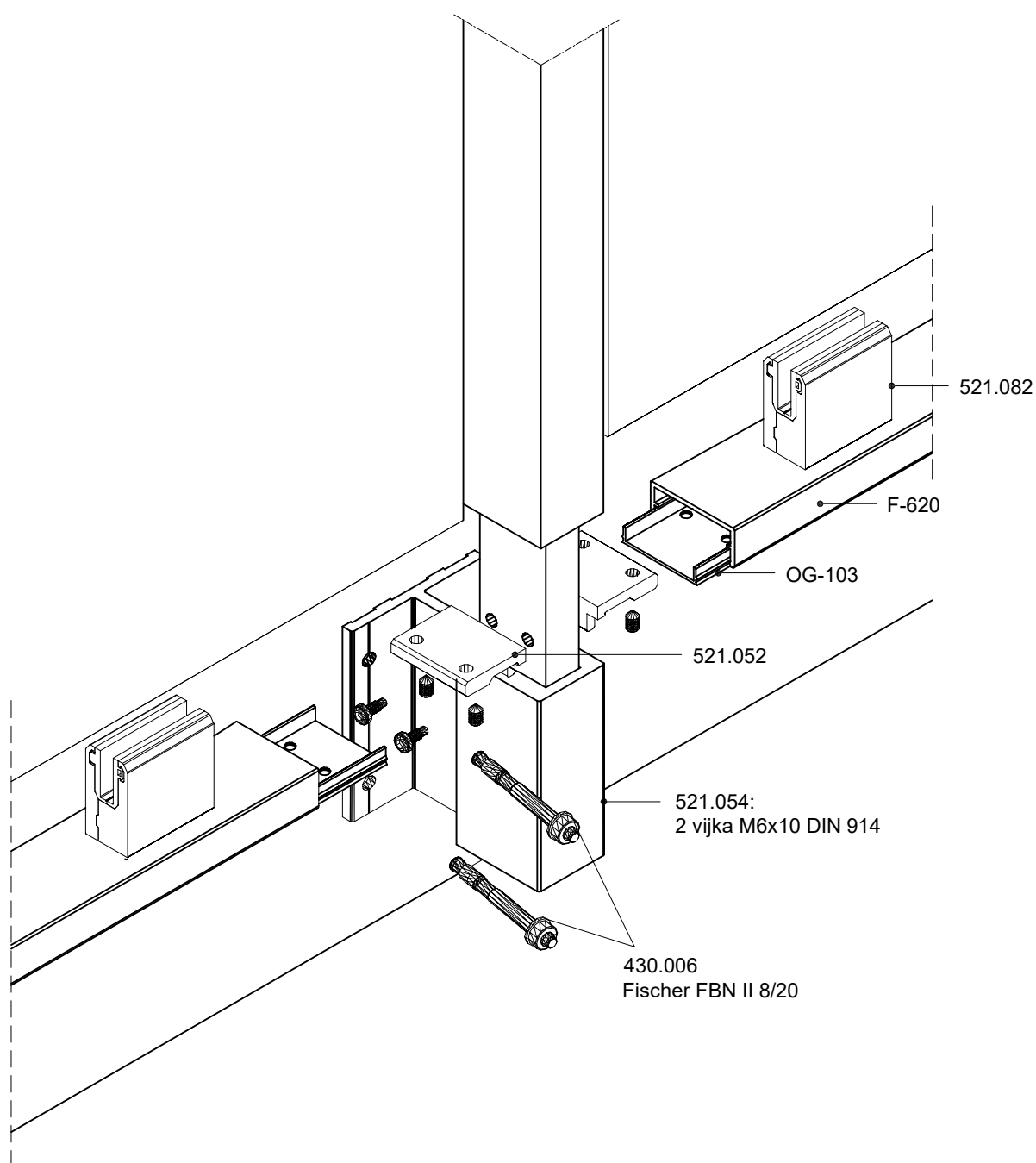
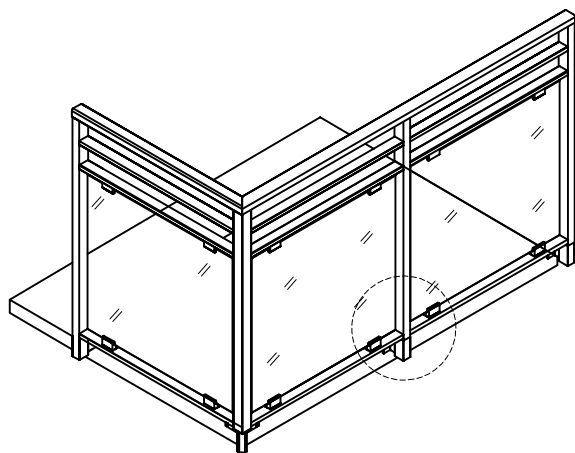

2 vijka 4.8x19 DIN7981  
1 Vijak M8x30 DIN 933  
za spajanje (F-0620)  
podrukhovata sa  
al. stubom (F-1246)

Vijci 4.8x19 DIN7981  
za spajanje (F-0620)  
podrukhovata  
sa (OG-111)

F-0689  
Rukohvat

F-0620  
podrukhovlat

373.007  
PVC Čep

OG-111

OG-111

F-0620

OG-103

521.044  
Stopa ograde pod kutom

H(F-0200)

H(F-1246)

30°

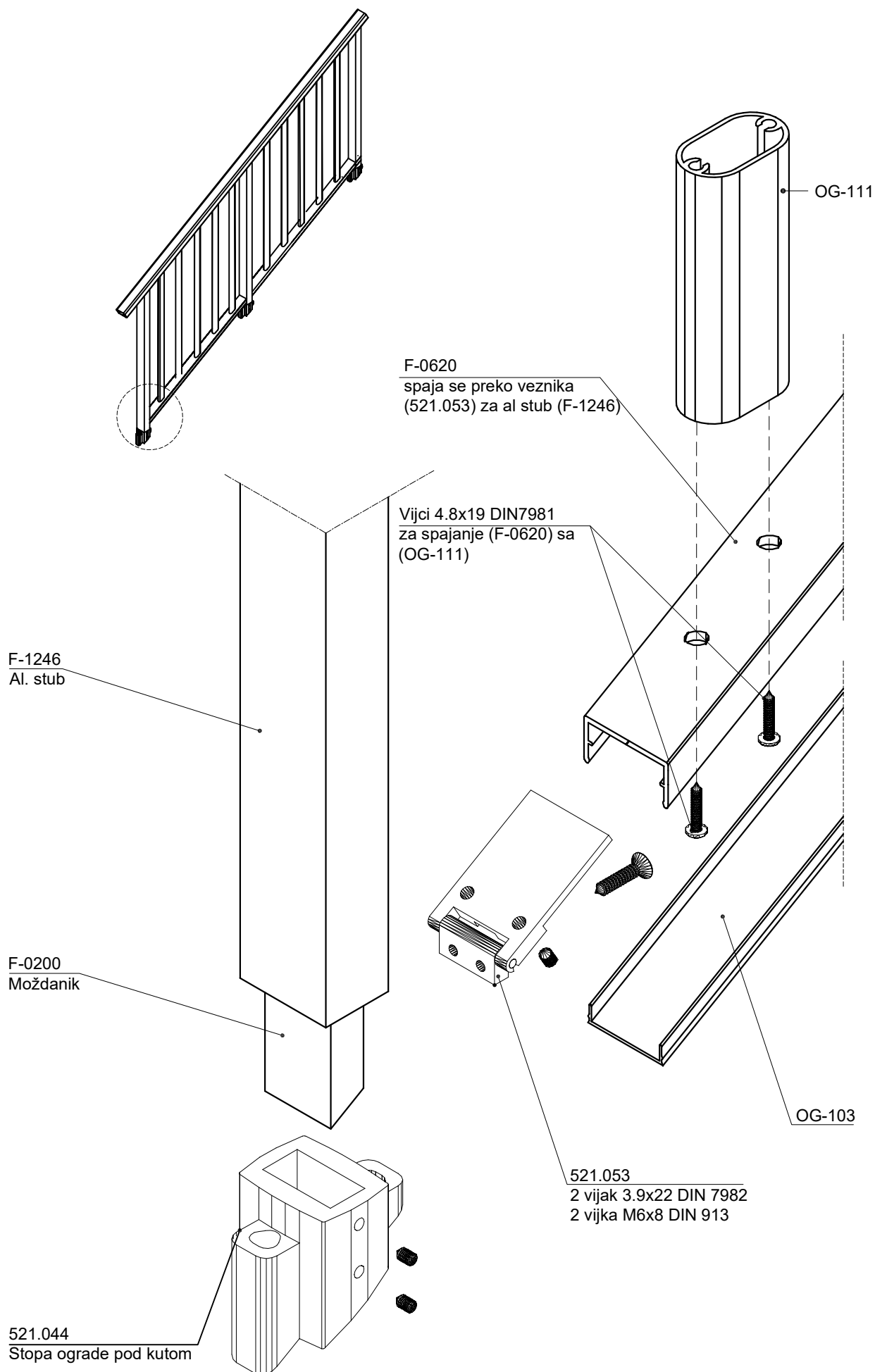

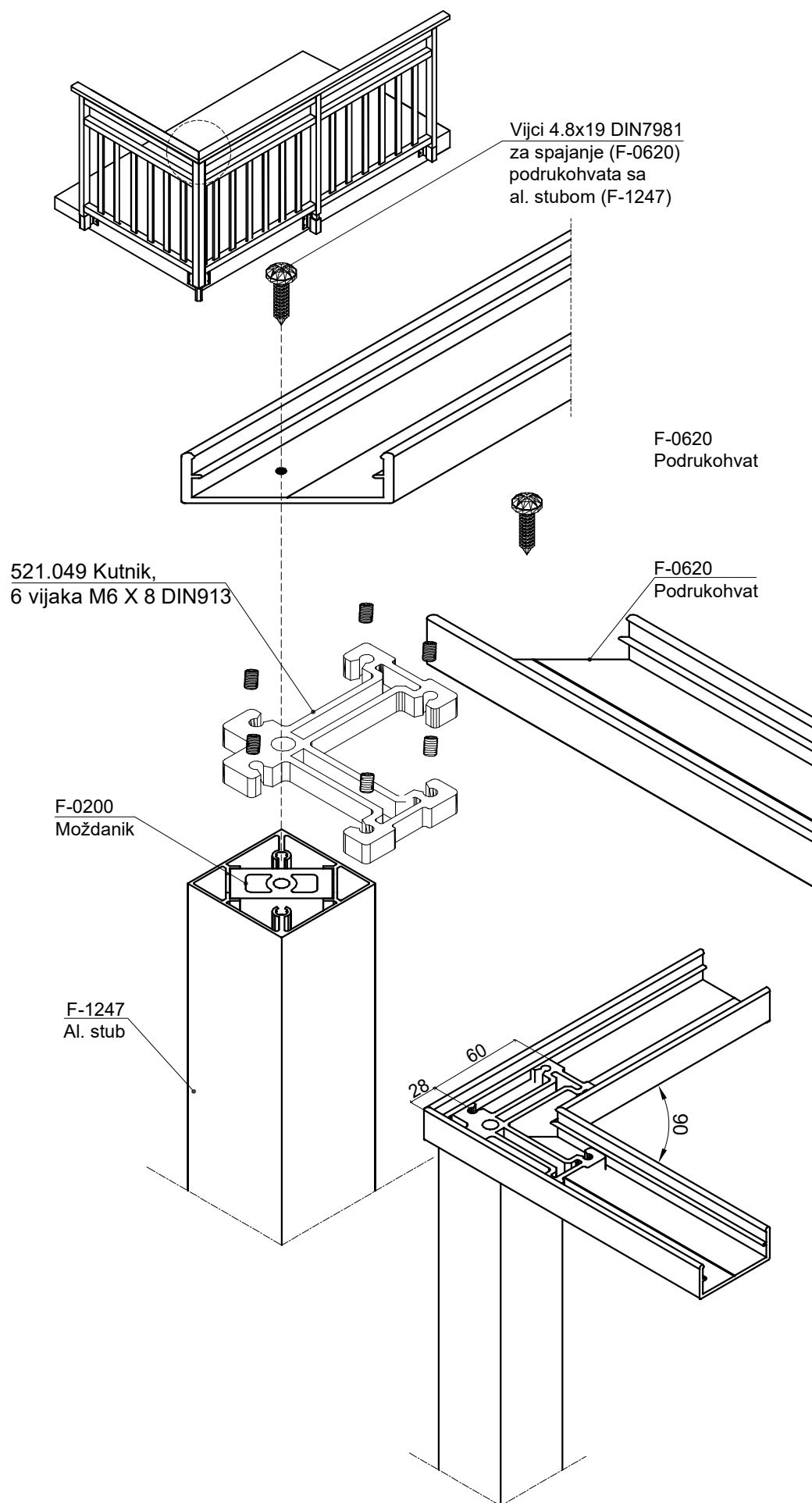

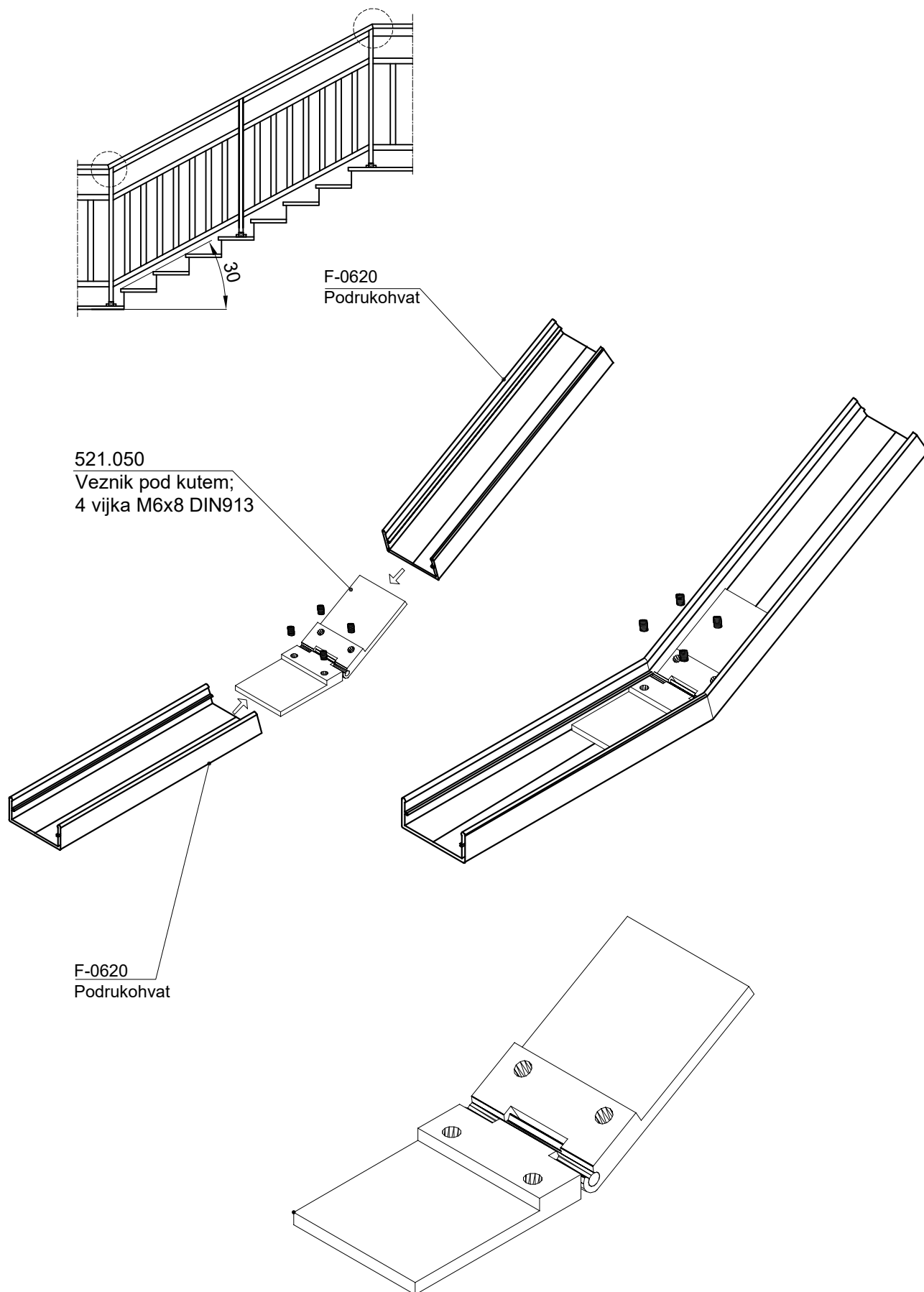

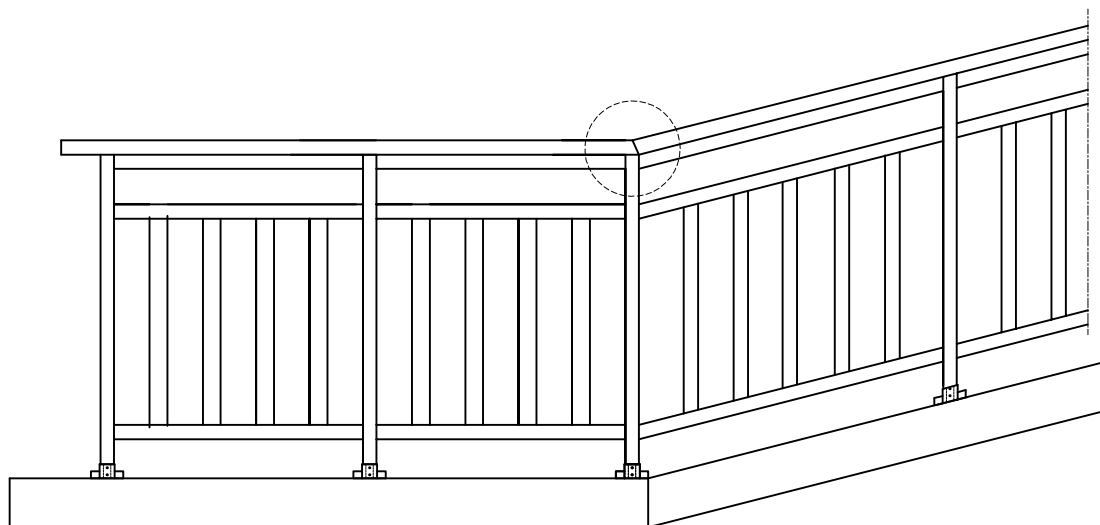

521.051  
 Veznik pod kutem;  
 4 vijka M6x8 DIN913

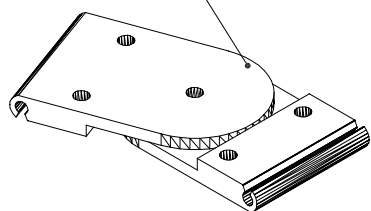

OG-V-03

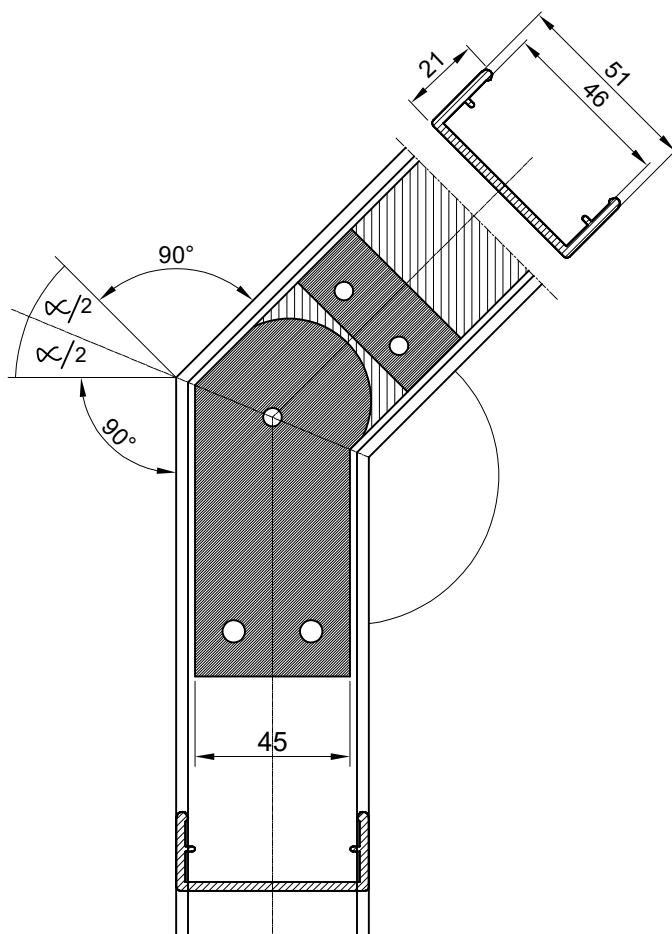

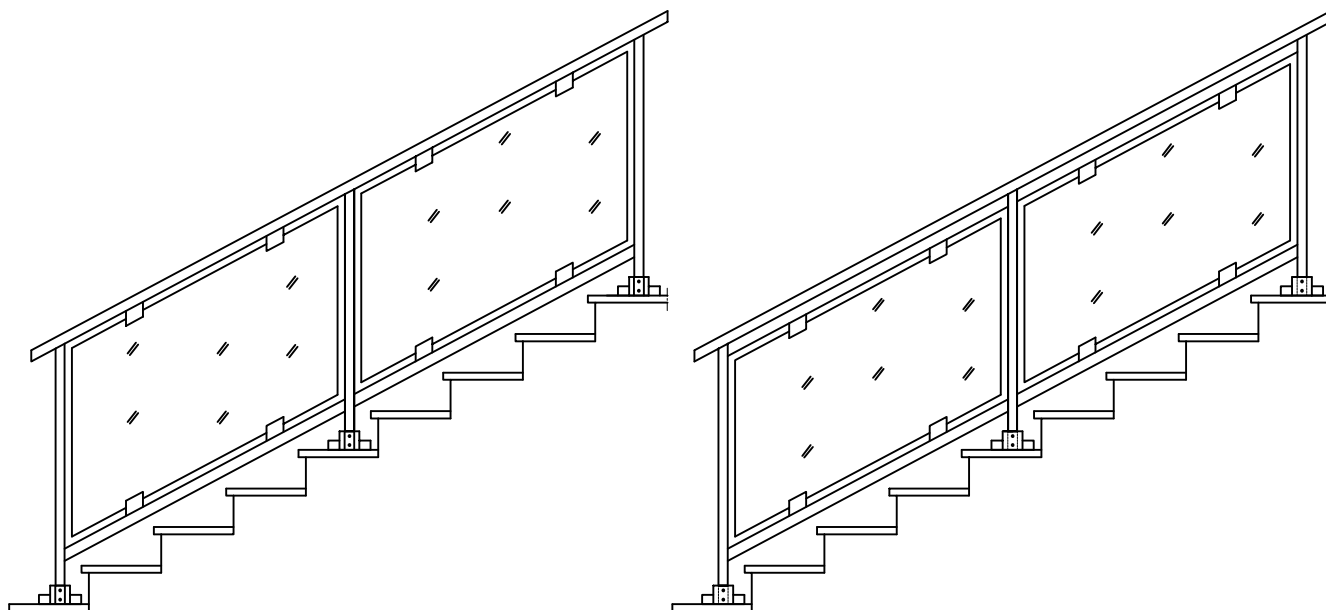

521.046 KOSI DRZAC

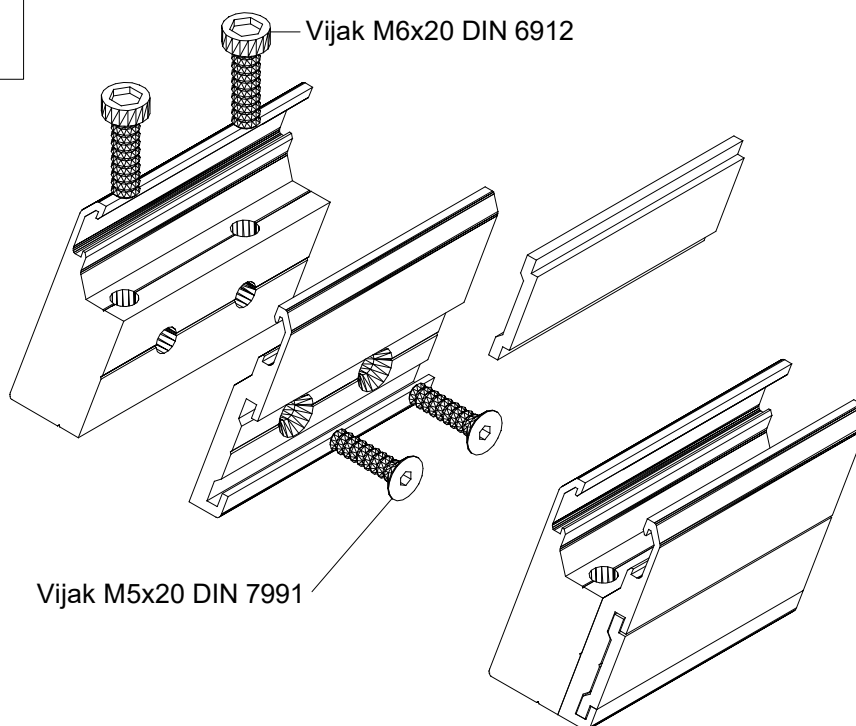
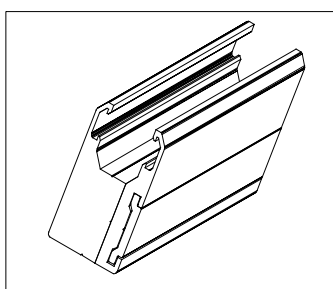

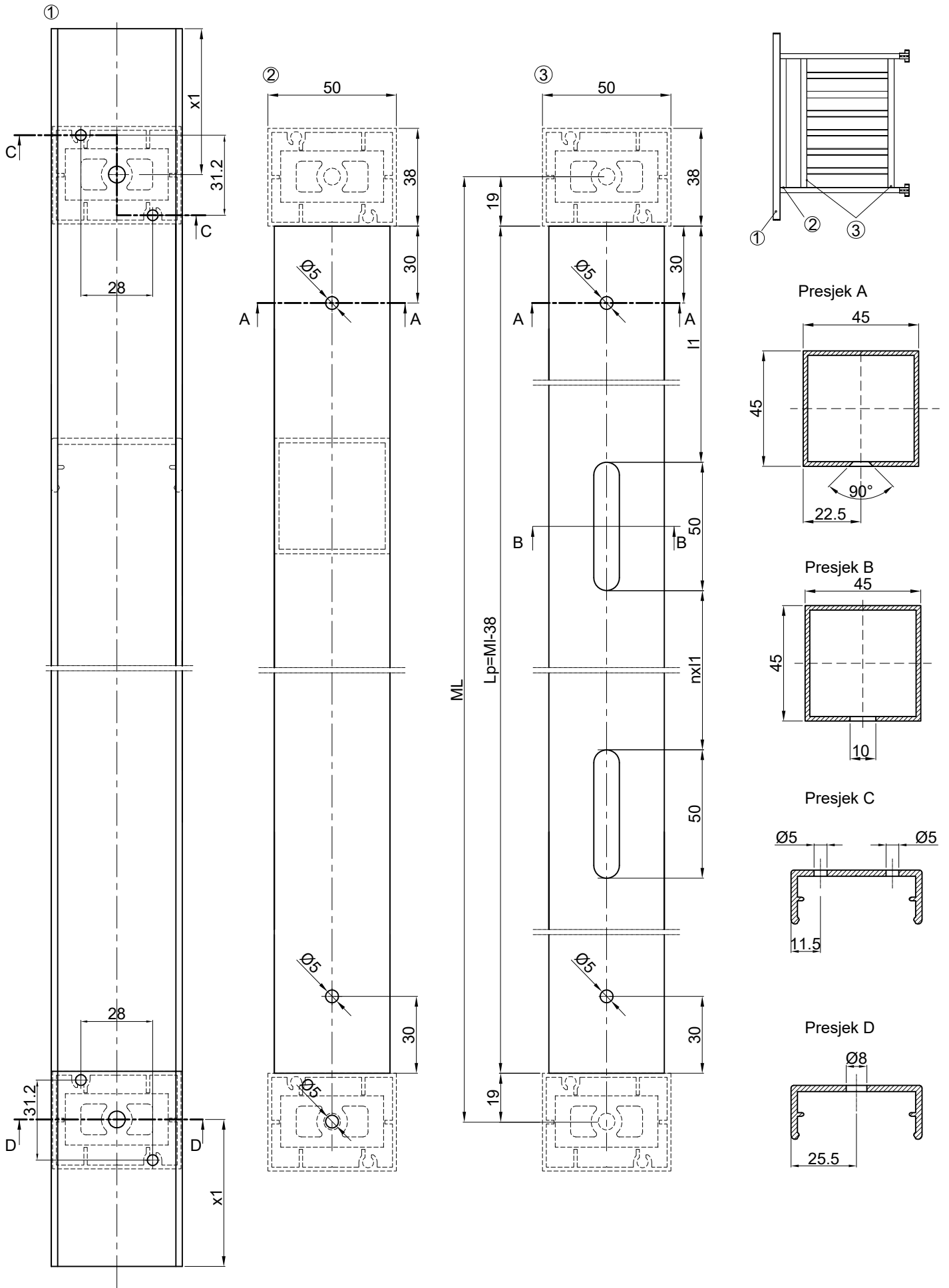

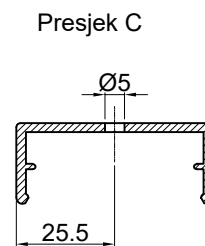
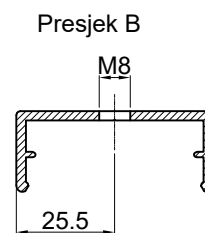
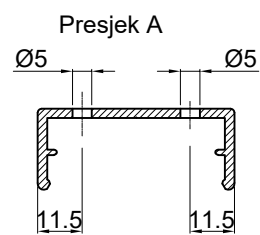
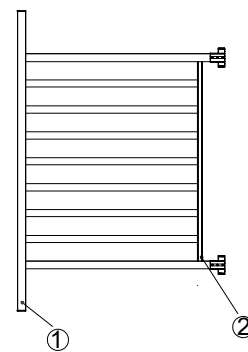
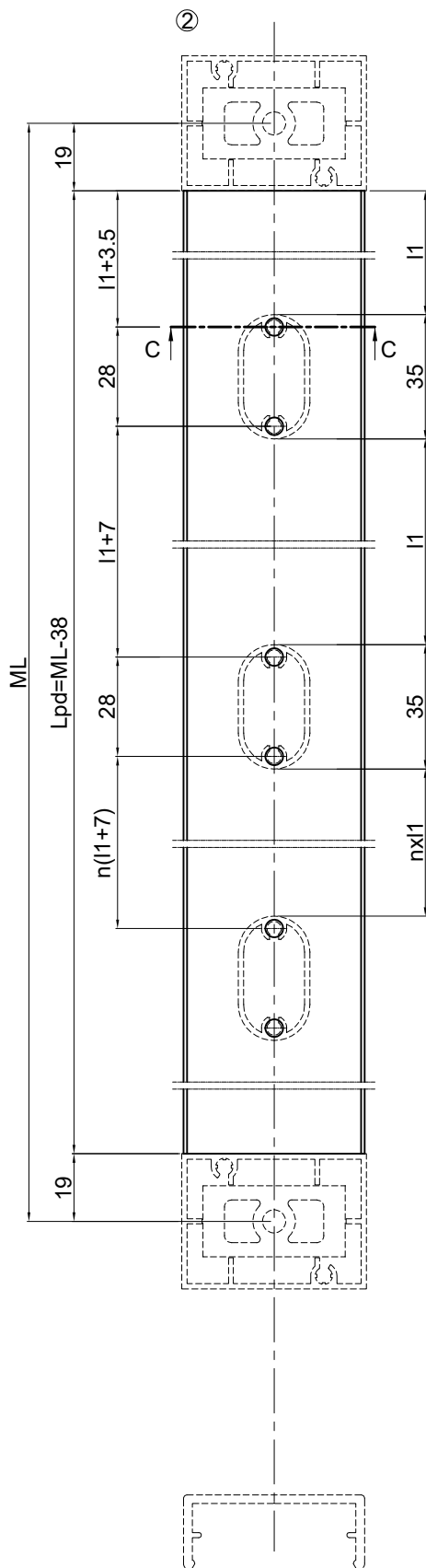
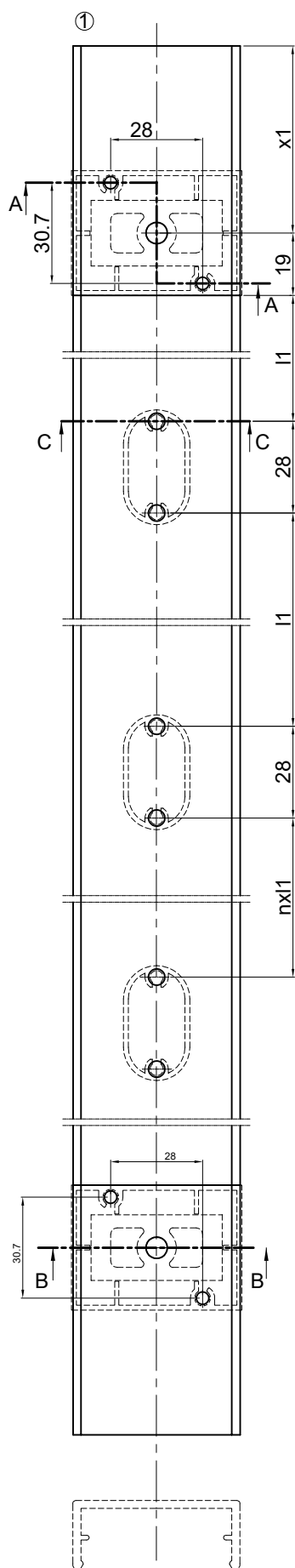



# Rezne liste



## TIP A

Aluminjska ograda sa ispunom F-0187 F-0187/A F-0187/L

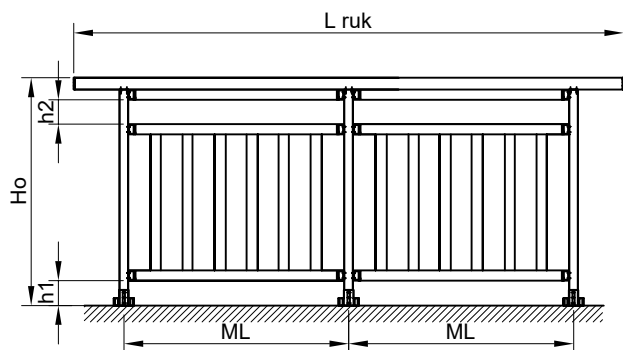

naziv	mjera	kom.	pilanje
<b>Profili</b>			
Moždanic F-0200	..... H=Ho-40	3	90-90
Maska moždanika OG-101	..... H=Ho-110	3	90-90
Prečka podrukohvatom F-0048	..... L=ML-38	2	90-90
Srednja prečka F-0048	..... L=ML-38	2	90-90
Donja prečka F-0048	..... L=ML-38	2	90-90
Podrukohvat F-0620	..... L ruk	1	90-90
Rukohvat F-0689	..... L ruk	1	90-90
Ispuna F-0187	..... Hisp=Hog-(88.6+h1+h2)		90-90

**Vezni elementi**

Stopa ograde 521.043	.....	3	
Veznik 521.048	.....	12	
Bočni čep rukohvata 373.007	.....	2	

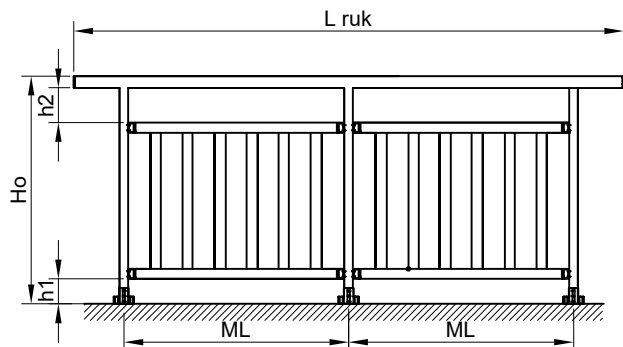

naziv	mjera	kom.	pilanje
<b>Profili</b>			
Moždanic F-0200	..... H=Ho-40	3	90-90
Maska moždanika OG-101	..... H=Ho-110	3	90-90
Gornja prečka F-0048	..... L=ML-38	2	90-90
Donja prečka F-0048	..... L=ML-38	2	90-90
Podrukohvat F-0620	..... L ruk	1	90-90
Rukohvat F-0689	..... L ruk	1	90-90
Ispuna F-0187/A	..... Hisp=Hog-(89+h1+h2)		90-90

**Vezni elementi**

Stopa ograde 521.043	.....	3	
Veznik 521.048	.....	8	
Bočni čep rukohvata 373.007	.....	2	

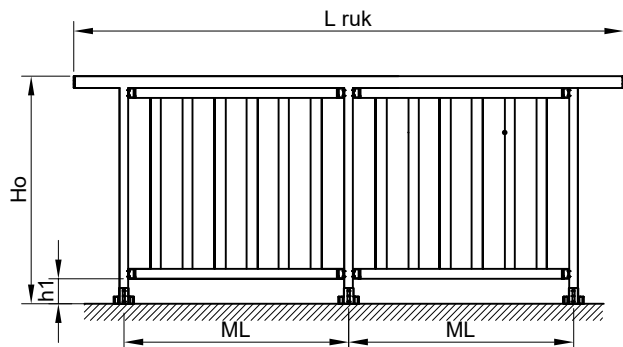

naziv	mjera	kom.	pilanje
<b>Profili</b>			
Moždanic F-0200	..... H=Ho-40	3	90-90
Maska moždanika OG-101	..... H=Ho-110	3	90-90
Prečka podrukohvatom F-0048	..... L=ML-38	2	90-90
Donja prečka F-0048	..... L=ML-38	2	90-90
Podrukohvat F-0620	..... L ruk	1	90-90
Rukohvat F-0689	..... L ruk	1	90-90
Ispuna F-0187/L	..... Hisp=Hog-(89+h1+h2)		90-90

**Vezni elementi**

Stopa ograde 521.043	.....	3	
Veznik 521.048	.....	8	
Bočni čep rukohvata 373.007	.....	2	

TIP B  
Aluminjska ograda sa ispunom OG-111

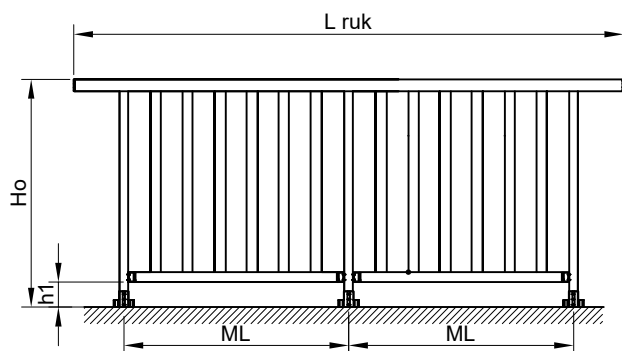

naziv	mjera	kom.	pilanje
<b>Profili</b>			
Moždanic F-0200	..... H=Ho-40	3	90-90
Maska moždanika OG-101	..... H=Ho-110	3	90-90
F-620	..... L=ML-38	2	90-90
OG-103	..... L=ML-38	2	90-90
Podrukohvat F-0620	..... L ruk	1	90-90
Rukohvat F-0689	..... L ruk	1	90-90
Ispuna OG-111	..... Hisp=Hog-(h1+60.5)		90-90

**Vezni elementi**

Stopa ograde 521.043	.....	3	
Veznik 521.052	.....	4	
Bočni čep rukohvata 373.007	.....	2	

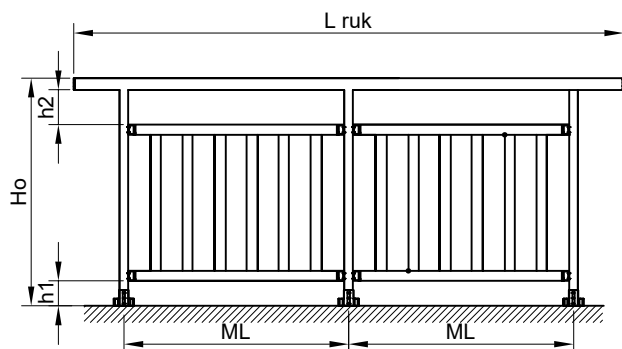

naziv	mjera	kom.	pilanje
<b>Profili</b>			
Moždanic F-0200	..... H=Ho-40	3	90-90
Maska moždanika OG-101	..... H=Ho-110	3	90-90
F-620	..... L=ML-38	4	90-90
OG-103	..... L=ML-38	4	90-90
Podrukohvat F-0620	..... L ruk	1	90-90
Rukohvat F-0689	..... L ruk	1	90-90
Ispuna OG-111	..... Hisp=Hog-(h1+h2+60.5)		90-90

**Vezni elementi**

Stopa ograde 521.043	.....	3	
Veznik 521.052	.....	8	
Bočni čep rukohvata 373.007	.....	2	

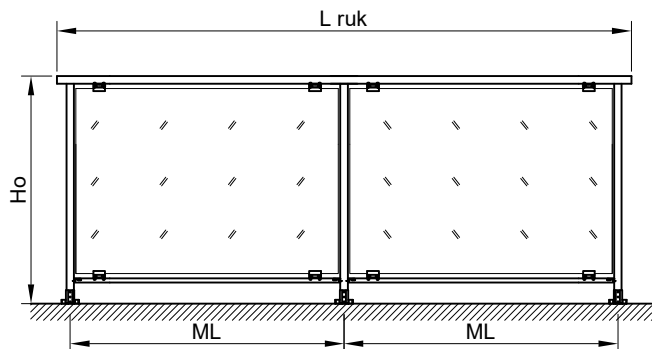
TIP C  
 Staklena ograda

naziv	mjera	kom.	pilanje
<b>Profili</b>			
Moždanik F-0200	..... H=Ho-40	3	90-90
Maska moždanika OG-101	..... H=Ho-110	3	90-90
Donja prečka F-0620	..... L=ML-38	2	90-90
Maska prečke OG-103	..... L=ML-38	3	90-90
Podrukohvat F-0620	..... L ruk	1	90-90
Rukohvat F-0689	..... L ruk	1	90-90

**Vezni elementi**

Stopa ograde 521.043	.....	3	
Držaš stakla (44.2) 521.045	.....	8	
Veznik 521.052	.....	4	
Bočni čep rukohvata 373.007	.....	2	

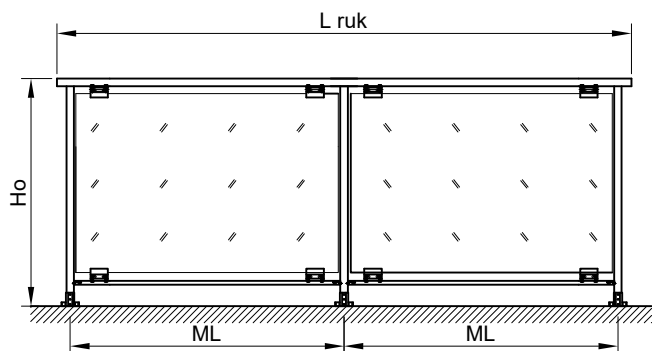

naziv	mjera	kom.	pilanje
<b>Profili</b>			
Moždanik F-0200	..... H=Ho-40	3	90-90
Maska moždanika OG-101	..... H=Ho-110	3	90-90
Donja prečka F-0620	..... L=ML-38	2	90-90
Maska prečke OG-103	..... L=ML-38	3	90-90
Podrukohvat F-0620	..... L=ML+x1+x2	1	90-90
Rukohvat F-0689	..... L=ML+x1+x2	1	90-90

**Vezni elementi**

Stopa ograde 521.043	.....	3	
Držaš stakla (55.2) 521.082	.....	8	
Veznik 521.052	.....	4	
Bočni čep rukohvata 373.007	.....	2	





# FEAL

## OF 60

Lipanj 2023. / *June 2023*

FEAL d.o.o.  
Trnska cesta 146  
88220 Široki Brijeg  
Bosna i Hercegovina  
Tel. +387 39 704-269; 705-807; 705-636  
Fax. +387 39 704-358  
info@feal.ba  
www.feal.ba