

# FEAL

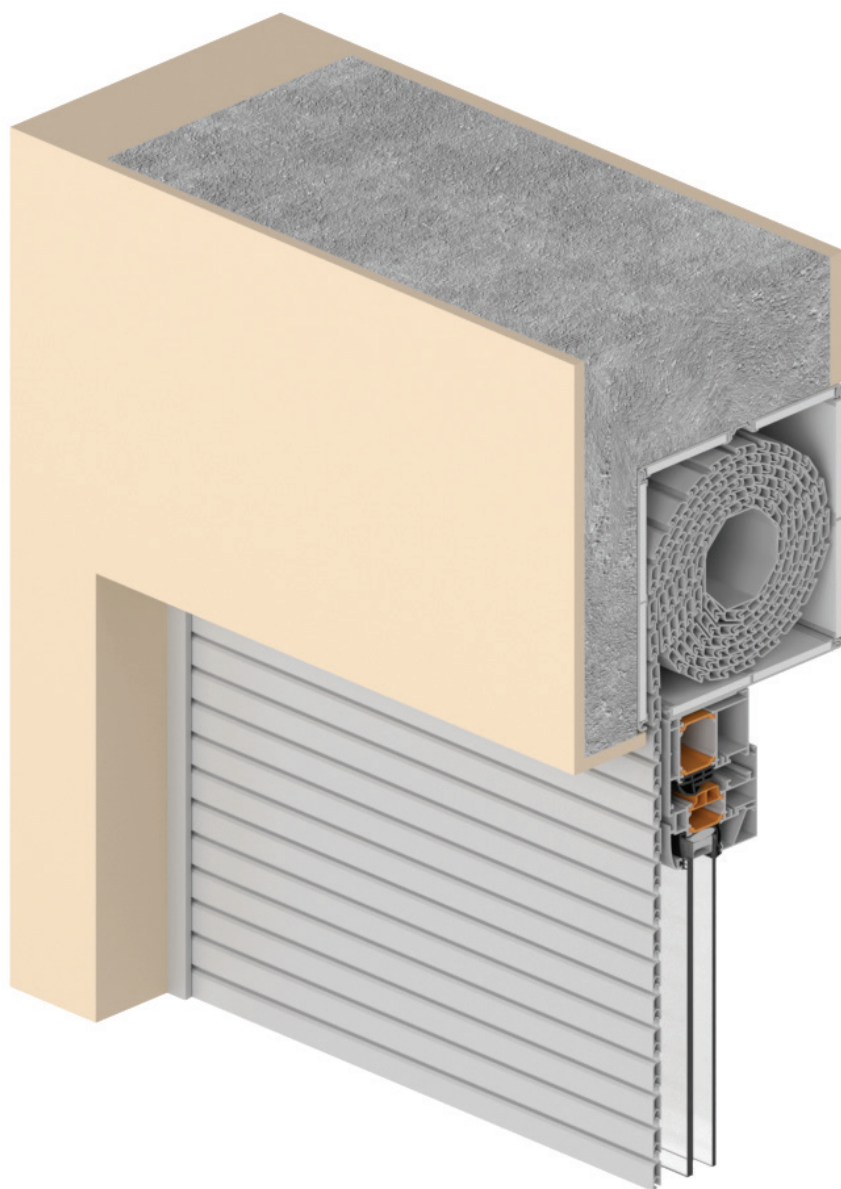

## SP SJENILA

*ROLLER SHUTTER*



01	ZNAČAJKE SISTEMA	100.01.000-003
03	PROFILI	100.03.000-013
04	VEZNI ELEMENTI	100.04.000-003
05	PVC ELEMENTI	100.05.000-003
06	MEHANIZMI	100.06.000-007
07	BRTVE	100.07.000-003
08	DODACI	100.08.000-003
10	PRESJECI	100.10.000-021
11	OBRADA I MONTAŽA	100.11.000-017



# Značajke sistema



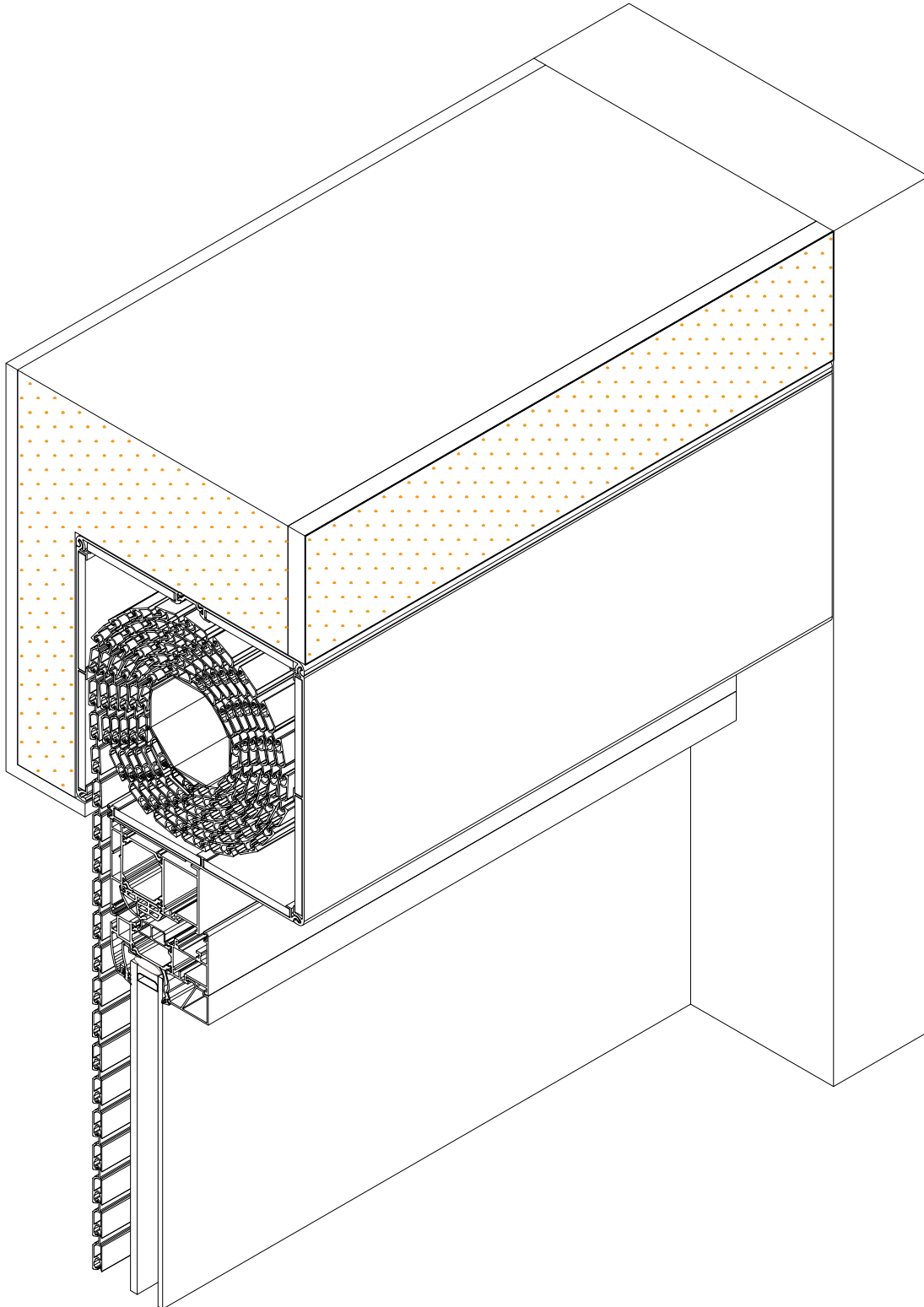

**OPIS SISTEMA SP sjenila:**

Sistem **SP sjenila** je namijenjen za zaštitu protiv sunčeve svjetlosti i atmosferskih utjecaja. Sistem zatamnjuje prostoriju, pruža privatnost i ima moderan, atraktivan i elegantan izgled. Sjenila će obeshrabriti uljeze i pružiti zaštitu od provale što ih čini idealnim za privatnu i komercijalnu upotrebu.

SP sjenila su dostupna u tri veličine lamela (10, 20, 50 mm).

Sistem može biti montiran na sve tipove prozora i vrata, a montaža je brza i jednostavna. Lamelle su dostupne u širokoj paleti boja (u boji prema RAL karti, eloksaža te imitacija drveta). SP sjenila mogu biti pogonjene ručno ili pomoću motora.

Posebno su pogodne za prizemne prozore ili vrata na privatnim, prodajnim, ili komercijalnim objektima.

- maksimalna visina do 3000 mm
- široki raspon RAL boja
- 3 veličine lamela (10, 20, 50 mm).
- 8 različitih tipova vodilica
- 6 različitih tipova završnih lamela
- tihi rad s naglaskom na minimalnu buku i vibraciju

# Profili



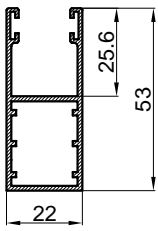

**F-0608**  
kg/m 0.607

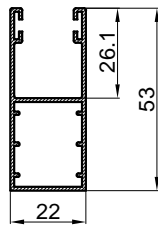

**F-0608/C**  
kg/m 0.507

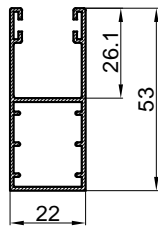

**F-0608/M**  
kg/m 0.51

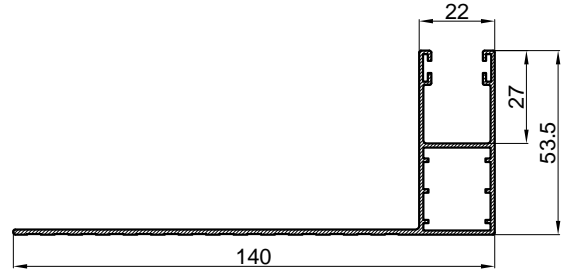

**F-0920**  
kg/m 0.992

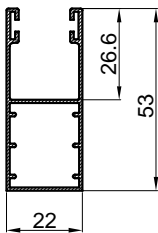

**F-0608/L**  
kg/m 0.445

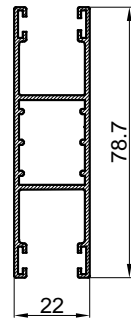

**F-0607**  
kg/m 0.863

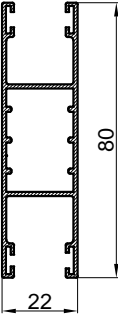

**F-0607/M**  
kg/m 0.783

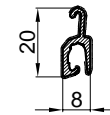

**F-1087**  
kg/m 0.15

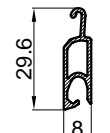

**F-1330**  
kg/m 0.206

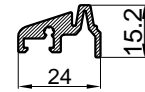

**F-1439**  
kg/m 0.344

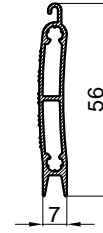

**F-1412**  
kg/m 0.382

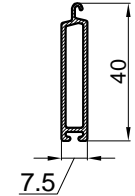

**F-1105**  
kg/m 0.284

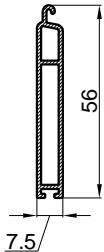

**F-0685**  
kg/m 0.460

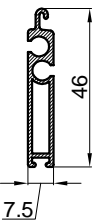

**F-0815**  
kg/m 0.368

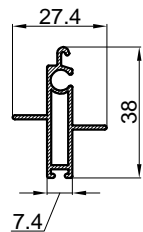

**F-0827**  
kg/m 0.342

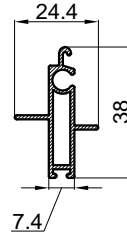

**F-0827/A**  
kg/m 0.333

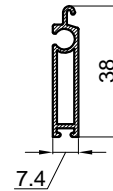

**F-0830**  
kg/m 0.278

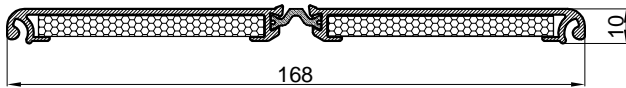

**FT-0151**  
kg/m 1.115

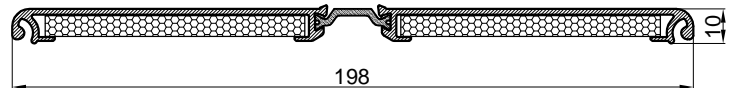

**FT-0159**  
kg/m 1.231

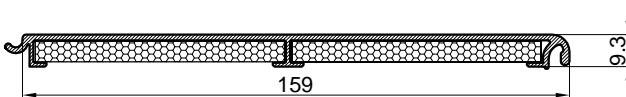

**F-0885/A**  
kg/m 0.937

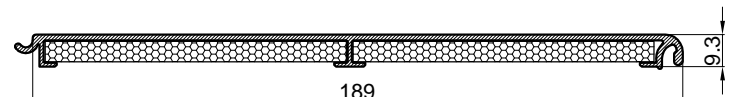

**F-0993**  
kg/m 1.075

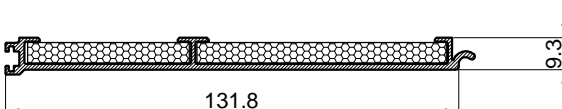

**F-0886**  
kg/m 0.795

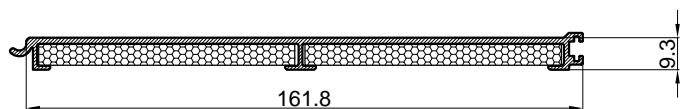

**F-0994**  
kg/m 0.931

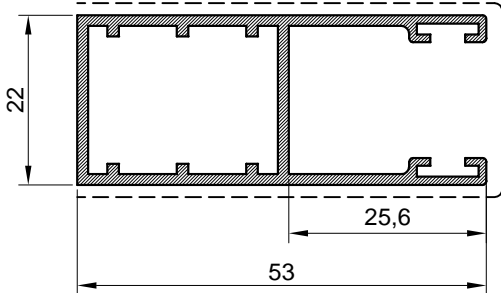

Vodilice		
Art.-Br.	<b>F-0608</b>	
Težina	kg/m'	<b>0.607</b>
Opseg	mm	<b>231.00</b>
Moment inercije	I <sub>x</sub> (cm <sup>4</sup> )	<b>1.9011</b>
	I <sub>y</sub> (cm <sup>4</sup> )	<b>5.8663</b>
	W <sub>x</sub> (cm <sup>3</sup> )	<b>1.7283</b>
	W <sub>y</sub> (cm <sup>3</sup> )	<b>2.0063</b>
Dužina isporuke	mm	<b>6500</b>

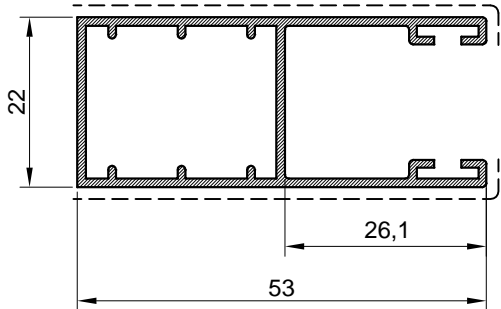

Vodilice		
Art.-Br.	<b>F-0608/C</b>	
Težina	kg/m'	<b>0.507</b>
Opseg	mm	<b>237.54</b>
Moment inercije	I <sub>x</sub> (cm <sup>4</sup> )	<b>1.6243</b>
	I <sub>y</sub> (cm <sup>4</sup> )	<b>5.2289</b>
	W <sub>x</sub> (cm <sup>3</sup> )	<b>1.4766</b>
	W <sub>y</sub> (cm <sup>3</sup> )	<b>1.8628</b>
Dužina isporuke	mm	<b>6500</b>

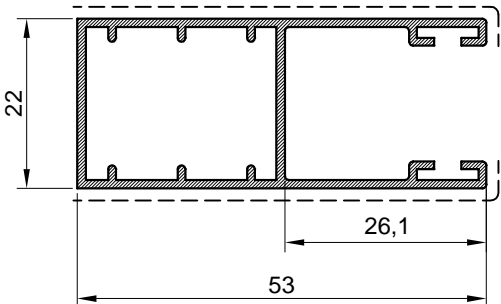

Vodilice		
Art.-Br.	<b>F-0608/M</b>	
Težina	kg/m'	<b>0.51</b>
Opseg	mm	<b>237.54</b>
Moment inercije	I <sub>x</sub> (cm <sup>4</sup> )	<b>1.6354</b>
	I <sub>y</sub> (cm <sup>4</sup> )	<b>5.2565</b>
	W <sub>x</sub> (cm <sup>3</sup> )	<b>1.4867</b>
	W <sub>y</sub> (cm <sup>3</sup> )	<b>1.8666</b>
Dužina isporuke	mm	<b>6500</b>

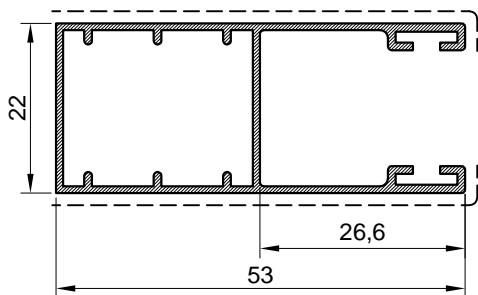

Vodilice		
Art.-Br.	<b>F-0608/L</b>	
Težina	kg/m'	<b>0.445</b>
Opseg	mm	<b>238.62</b>
Moment inercije	I <sub>x</sub> (cm <sup>4</sup> )	<b>1.743</b>
	I <sub>y</sub> (cm <sup>4</sup> )	<b>4.767</b>
	W <sub>x</sub> (cm <sup>3</sup> )	<b>1.316</b>
	W <sub>y</sub> (cm <sup>3</sup> )	<b>1.743</b>
Dužina isporuke	mm	<b>6500</b>

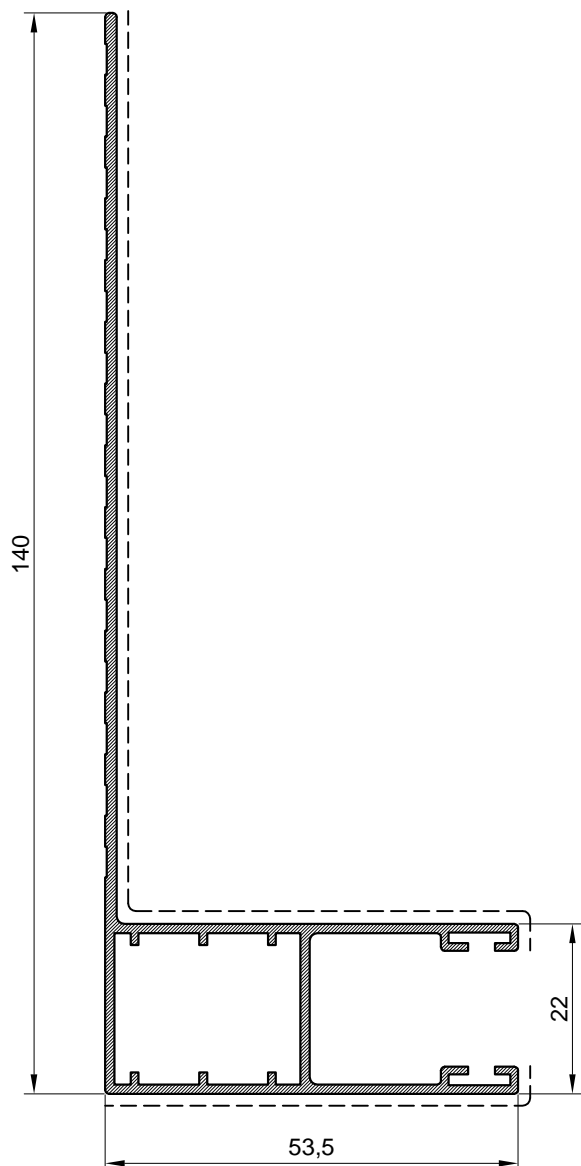

Vodilice		
Art.-Br.	<b>F-0920</b>	
Težina	kg/m'	<b>0.992</b>
Opseg	mm	<b>480.00</b>
Moment inercije	I <sub>x</sub> (cm <sup>4</sup> )	<b>65.4872</b>
	I <sub>y</sub> (cm <sup>4</sup> )	<b>10.8139</b>
	W <sub>x</sub> (cm <sup>3</sup> )	<b>6.7187</b>
	W <sub>y</sub> (cm <sup>3</sup> )	<b>2.7315</b>
Dužina isporuke	mm	<b>6500</b>

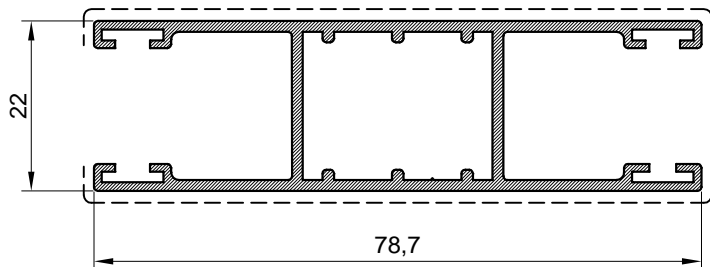

Vodilice		
Art.-Br.	<b>F-0607</b>	
Težina	kg/m'	<b>0.863</b>
Opseg	mm	<b>363.91</b>
Moment inercije	I <sub>x</sub> (cm <sup>4</sup> )	<b>2.7319</b>
	I <sub>y</sub> (cm <sup>4</sup> )	<b>14.9998</b>
	W <sub>x</sub> (cm <sup>3</sup> )	<b>2.4835</b>
	W <sub>y</sub> (cm <sup>3</sup> )	<b>3.8013</b>
Dužina isporuke	mm	<b>6500</b>

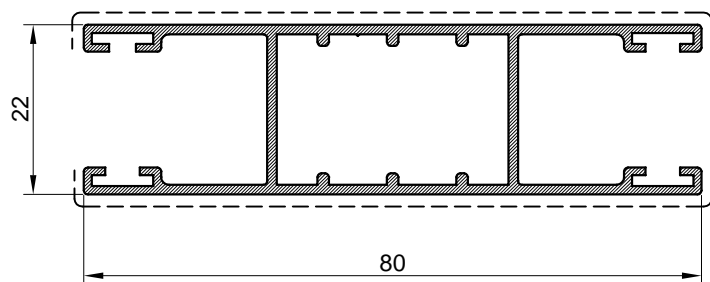

Vodilice		
Art.-Br.	<b>F-0607/M</b>	
Težina	kg/m'	<b>0.783</b>
Opseg	mm	<b>361.00</b>
Moment inercije	I <sub>x</sub> (cm <sup>4</sup> )	<b>2.6044</b>
	I <sub>y</sub> (cm <sup>4</sup> )	<b>15.4229</b>
	W <sub>x</sub> (cm <sup>3</sup> )	<b>2.3676</b>
	W <sub>y</sub> (cm <sup>3</sup> )	<b>3.8442</b>
Dužina isporuke	mm	<b>6500</b>

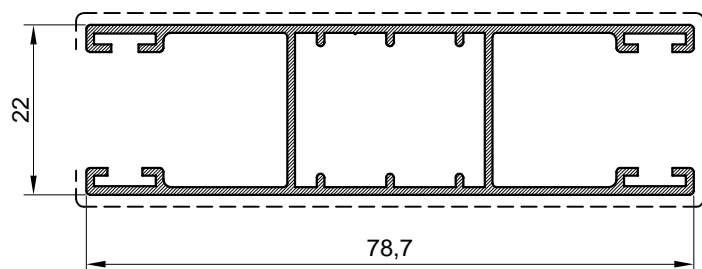

Vodilice		
Art.-Br.	<b>F-0607/L</b>	
Težina	kg/m'	<b>0.664</b>
Opseg	mm	<b>369.64</b>
Moment inercije	I <sub>x</sub> (cm <sup>4</sup> )	<b>13.389</b>
	I <sub>y</sub> (cm <sup>4</sup> )	<b>2.24</b>
	W <sub>x</sub> (cm <sup>3</sup> )	<b>3.389</b>
	W <sub>y</sub> (cm <sup>3</sup> )	<b>2.036</b>
Dužina isporuke	mm	<b>6500</b>

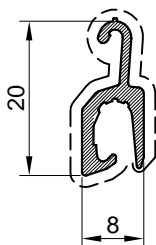

Lamela		
Art.-Br.	<b>F-1087</b>	
Težina	kg/m'	<b>0.15</b>
Opseg	mm	<b>80.49</b>
Moment inercije	I <sub>x</sub> (cm <sup>4</sup> )	-
	I <sub>y</sub> (cm <sup>4</sup> )	-
	W <sub>x</sub> (cm <sup>3</sup> )	-
	W <sub>y</sub> (cm <sup>3</sup> )	-
Dužina isporuke	mm	-

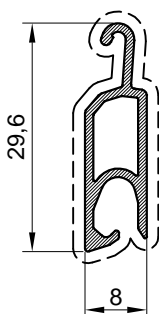

Lamela		
Art.-Br.	<b>F-1330</b>	
Težina	kg/m'	<b>0.206</b>
Opseg	mm	<b>97.03</b>
Moment inercije	I <sub>x</sub> (cm <sup>4</sup> )	-
	I <sub>y</sub> (cm <sup>4</sup> )	-
	W <sub>x</sub> (cm <sup>3</sup> )	-
	W <sub>y</sub> (cm <sup>3</sup> )	-
Dužina isporuke	mm	-

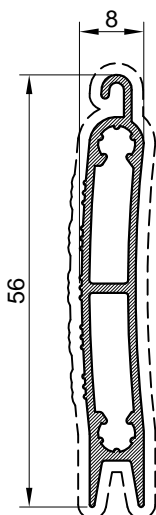

Lamela		
Art.-Br.	<b>F-1412</b>	
Težina	kg/m'	<b>0.382</b>
Opseg	mm	<b>145.42</b>
Moment inercije	I <sub>x</sub> (cm <sup>4</sup> )	<b>3.7110</b>
	I <sub>y</sub> (cm <sup>4</sup> )	<b>0.1058</b>
	W <sub>x</sub> (cm <sup>3</sup> )	<b>1.2726</b>
	W <sub>y</sub> (cm <sup>3</sup> )	<b>0.2423</b>
Dužina isporuke	mm	<b>6500</b>

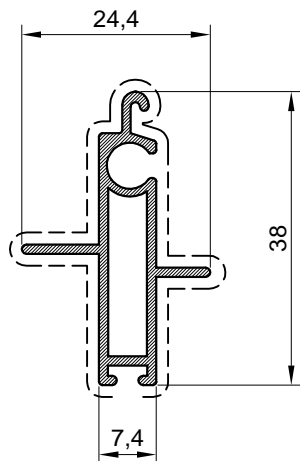

Završna lamela		
Art.-Br.	<b>F-0827/A</b>	
Težina	kg/m'	<b>0.333</b>
Opseg	mm	<b>148.80</b>
Moment inercije	I <sub>x</sub> (cm <sup>4</sup> )	<b>1.3142</b>
	I <sub>y</sub> (cm <sup>4</sup> )	<b>0.2180</b>
	W <sub>x</sub> (cm <sup>3</sup> )	<b>0.6448</b>
	W <sub>y</sub> (cm <sup>3</sup> )	<b>0.1645</b>
Dužina isporuke	mm	<b>6500</b>

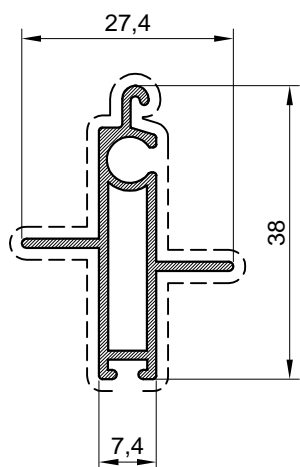

Završna lamela		
Art.-Br.	<b>F-0827</b>	
Težina	kg/m'	<b>0.342</b>
Opseg	mm	<b>154.80</b>
Moment inercije	I <sub>x</sub> (cm <sup>4</sup> )	<b>1.3174</b>
	I <sub>y</sub> (cm <sup>4</sup> )	<b>0.2731</b>
	W <sub>x</sub> (cm <sup>3</sup> )	<b>0.6439</b>
	W <sub>y</sub> (cm <sup>3</sup> )	<b>0.1979</b>
Dužina isporuke	mm	<b>6500</b>

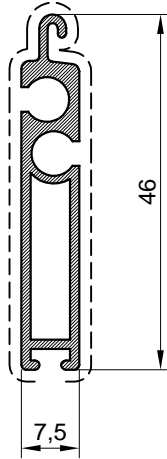

Završna lamela		
Art.-Br.	<b>F-0815</b>	
Težina	kg/m'	<b>0.368</b>
Opseg	mm	<b>147.00</b>
Moment inercije	I <sub>x</sub> (cm <sup>4</sup> )	<b>2.4569</b>
	I <sub>y</sub> (cm <sup>4</sup> )	<b>0.0990</b>
	W <sub>x</sub> (cm <sup>3</sup> )	<b>1.0608</b>
	W <sub>y</sub> (cm <sup>3</sup> )	<b>0.2633</b>
Dužina isporuke	mm	<b>6500</b>

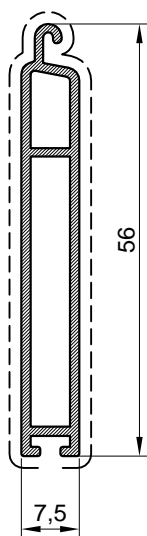

Završna lamela		
Art.-Br.	<b>F-0685</b>	
Težina	kg/m'	<b>0.447</b>
Opseg	mm	<b>139.00</b>
Moment inercije	I <sub>x</sub> (cm <sup>4</sup> )	<b>4.1549</b>
	I <sub>y</sub> (cm <sup>4</sup> )	<b>0.1270</b>
	W <sub>x</sub> (cm <sup>3</sup> )	<b>1.4293</b>
	W <sub>y</sub> (cm <sup>3</sup> )	<b>0.3333</b>
Dužina isporuke	mm	<b>6500</b>

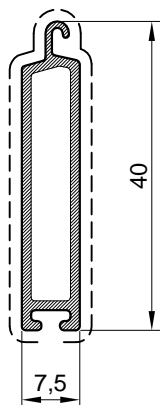

Završna lamela		
Art.-Br.	<b>F-1105</b>	
Težina	kg/m'	<b>0.284</b>
Opseg	mm	<b>106.00</b>
Moment inercije	I <sub>x</sub> (cm <sup>4</sup> )	-
	I <sub>y</sub> (cm <sup>4</sup> )	-
	W <sub>x</sub> (cm <sup>3</sup> )	-
	W <sub>y</sub> (cm <sup>3</sup> )	-
Dužina isporuke	mm	<b>6500</b>

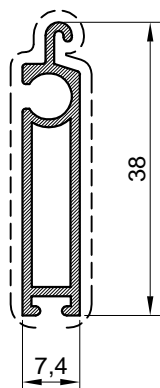

Završna lamela		
Art.-Br.	<b>F-0830</b>	
Težina	kg/m'	<b>0.278</b>
Opseg	mm	<b>116.70</b>
Moment inercije	I <sub>x</sub> (cm <sup>4</sup> )	<b>1.2973</b>
	I <sub>y</sub> (cm <sup>4</sup> )	<b>0.0771</b>
	W <sub>x</sub> (cm <sup>3</sup> )	<b>0.6422</b>
	W <sub>y</sub> (cm <sup>3</sup> )	<b>0.2008</b>
Dužina isporuke	mm	<b>6500</b>

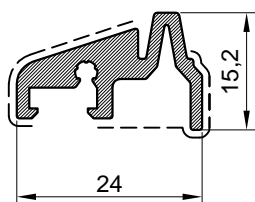

Završna lamela		
Art.-Br.	<b>F-1439</b>	
Težina	kg/m'	<b>0.344</b>
Opseg	mm	<b>116.74</b>
Moment inercije	I <sub>x</sub> (cm <sup>4</sup> )	<b>0.1311</b>
	I <sub>y</sub> (cm <sup>4</sup> )	<b>0.6056</b>
	W <sub>x</sub> (cm <sup>3</sup> )	<b>0.1643</b>
	W <sub>y</sub> (cm <sup>3</sup> )	<b>0.4896</b>
Dužina isporuke	mm	<b>6500</b>

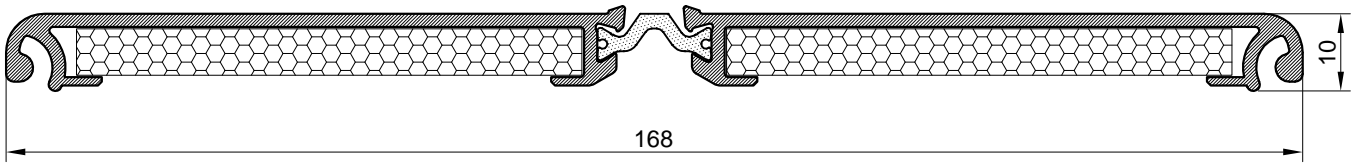

Termokutija 170		
Art.-Br.	<b>FT-0151</b>	
Težina	kg/m'	<b>1.108</b>
Opseg	mm	<b>461.00</b>
Moment inercije	I <sub>x</sub> (cm <sup>4</sup> )	-
	I <sub>y</sub> (cm <sup>4</sup> )	-
	W <sub>x</sub> (cm <sup>3</sup> )	-
	W <sub>y</sub> (cm <sup>3</sup> )	-
Dužina isporuke	mm	<b>6500</b>

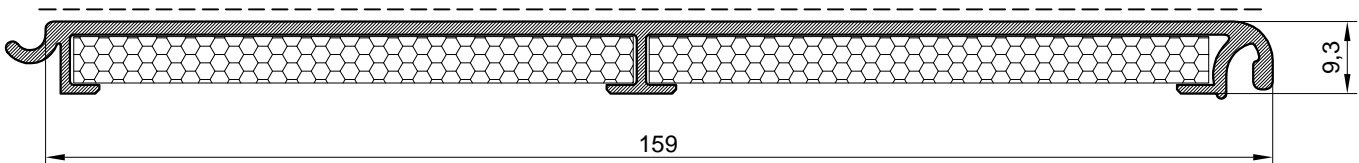

Termokutija 170		
Art.-Br.	<b>F-0885/A</b>	
Težina	kg/m'	<b>0.937</b>
Opseg	mm	<b>421.00</b>
Moment inercije	I <sub>x</sub> (cm <sup>4</sup> )	-
	I <sub>y</sub> (cm <sup>4</sup> )	-
	W <sub>x</sub> (cm <sup>3</sup> )	-
	W <sub>y</sub> (cm <sup>3</sup> )	-
Dužina isporuke	mm	<b>6500</b>

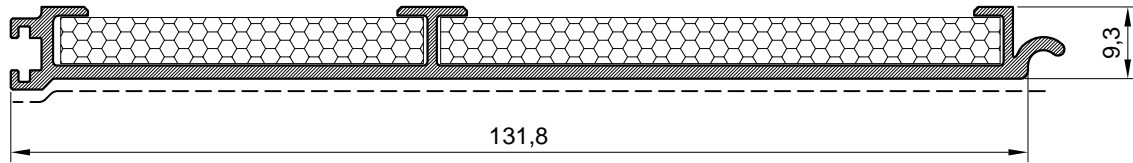

Termokutija 170		
Art.-Br.	<b>F-0886</b>	
Težina	kg/m'	<b>0.795</b>
Opseg	mm	<b>367.80</b>
Moment inercije	I <sub>x</sub> (cm <sup>4</sup> )	-
	I <sub>y</sub> (cm <sup>4</sup> )	-
	W <sub>x</sub> (cm <sup>3</sup> )	-
	W <sub>y</sub> (cm <sup>3</sup> )	-
Dužina isporuke	mm	<b>6500</b>

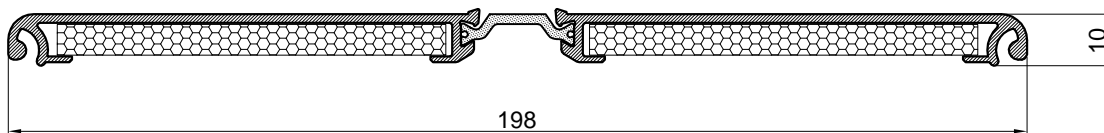

Termokutija 200		
Art.-Br.	<b>FT-0159</b>	
Težina	kg/m'	<b>1.231</b>
Opseg	mm	<b>493.00</b>
Moment inercije	I <sub>x</sub> (cm <sup>4</sup> )	-
	I <sub>y</sub> (cm <sup>4</sup> )	-
	W <sub>x</sub> (cm <sup>3</sup> )	-
	W <sub>y</sub> (cm <sup>3</sup> )	-
Dužina isporuke	mm	<b>6500</b>

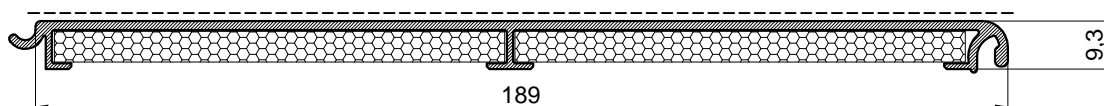

Termokutija 200		
Art.-Br.	<b>F-0993</b>	
Težina	kg/m'	<b>1.075</b>
Opseg	mm	<b>481.00</b>
Moment inercije	I <sub>x</sub> (cm <sup>4</sup> )	-
	I <sub>y</sub> (cm <sup>4</sup> )	-
	W <sub>x</sub> (cm <sup>3</sup> )	-
	W <sub>y</sub> (cm <sup>3</sup> )	-
Dužina isporuke	mm	<b>6500</b>

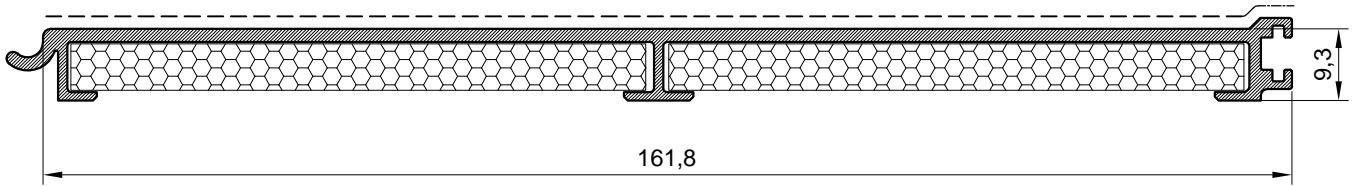

Termokutija 200		
Art.-Br.	<b>F-0994</b>	
Težina	kg/m'	<b>0.931</b>
Opseg	mm	<b>428.00</b>
Moment inercije	I <sub>x</sub> (cm <sup>4</sup> )	-
	I <sub>y</sub> (cm <sup>4</sup> )	-
	W <sub>x</sub> (cm <sup>3</sup> )	-
	W <sub>y</sub> (cm <sup>3</sup> )	-
Dužina isporuke	mm	<b>6500</b>

# Vezni elementi

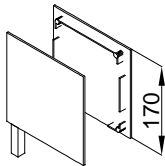
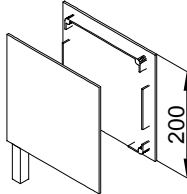
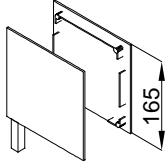
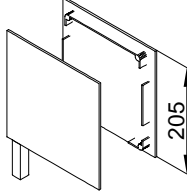
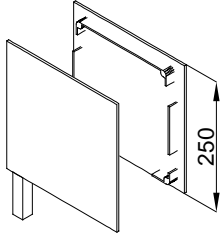
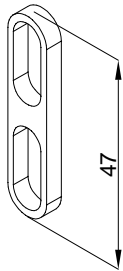
Oznaka	Izgled-presjek	Opis	Materijal	Nap.
380.003		<ul style="list-style-type: none"> <li>- Bočni poklopac termokutije 170</li> <li>- Lijevi i desni - par</li> </ul>		
380.004		<ul style="list-style-type: none"> <li>- Bočni poklopac termokutije 200</li> <li>- Lijevi i desni - par</li> </ul>		
380.005		<ul style="list-style-type: none"> <li>- Bočni poklopac kutije 165</li> <li>- Lijevi i desni - par</li> </ul>		
380.006		<ul style="list-style-type: none"> <li>- Bočni poklopac kutije 205</li> <li>- Lijevi i desni - par</li> </ul>		
380.007		<ul style="list-style-type: none"> <li>- Bočni poklopac kutije 250</li> <li>- Lijevi i desni - par</li> </ul>		
391.064		<ul style="list-style-type: none"> <li>- Prijenosnik lamele SP-50 (razmak među lamelama 18 mm)</li> </ul>	Al	

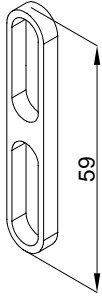
Oznaka	Izgled-presjek	Opis	Materijal	Nap.
391.080		- Prijenosnik lamele SP-50 (razmak među lamelama 30 mm)	Al	



# PVC elementi

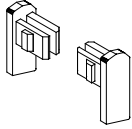
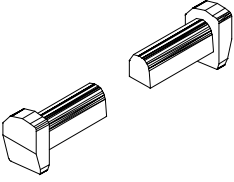
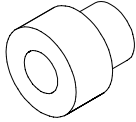
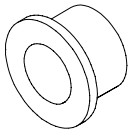
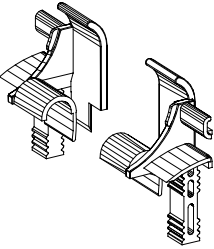
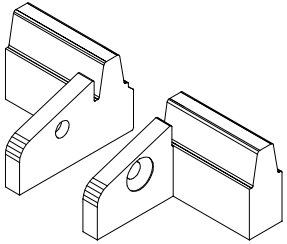

Oznaka	Izgled-presjek	Opis	Materijal	Nap.
373.029		<ul style="list-style-type: none"> <li>- Bočni čep lamele F-1330</li> <li>- Lijevi i desni - par</li> </ul>	PVC	
375.046		<ul style="list-style-type: none"> <li>- Bočni čep lamele F-1087</li> <li>- Stara oznaka: RC-1087</li> <li>- Lijevi i desni - par</li> </ul>	PVC	
375.061		<ul style="list-style-type: none"> <li>- Pvc distancer za lamelu SP 50 (razmak među lamelama 30 mm)</li> </ul>	PVC	
373.033		<ul style="list-style-type: none"> <li>- Pvc distancer za lamelu SP-50</li> </ul>	PVC	
375.062		<ul style="list-style-type: none"> <li>- Uvodnik lamele SP-50 u kutiju</li> <li>- Lijevi i desni par</li> </ul>	PVC	
375.060		<ul style="list-style-type: none"> <li>- Bočni čep završne lamele F-1439</li> <li>- Lijevi i desni - par</li> </ul>	PVC	



# Mehanizmi



## - Izbor motora za roletne -

Ove izračuni pomažu pri odabiru tubularnog motora ovisno o promjeru osovine i težine plašta.

**Nominalni moment = Težina x radijus podizanja**

- Vrijednost nominalnog momenta u Nm (Newton po metru) je iskazana na motoru.
- Radijus podizanja je zbroj radijusa osovine R1 i polovice debljine roletne R2.
- Težina plašta se dobiva umnoškom površine plašta i relativne težine sjenila prema tablici 1.

M 1:4

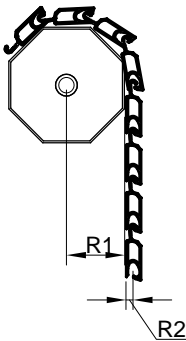

Primjer : - dimenzije plašta 2000 mm x 2500 mm

- osovina promjera 60 mm
- SP-20 sjenilo
- debljina sjenila 8 mm sa dimenzijom R2 = (8 mm/2) 4 mm

$$\begin{aligned} \text{Nominalni moment} &= (2000 \text{ mm}^2 \times 2500 \text{ mm}^2) \times (101 \text{ N/m}^2) \times (30 \text{ mm} + 4 \text{ mm}) \\ &= 5 \text{ m}^2 \times 101 \text{ N/m}^2 \times (0.034 \text{ m}) \\ &= 505 \text{ N} \times 0.034 \text{ m} \\ &= 17.17 \text{ Nm} \end{aligned}$$

**!** Zbog sigurnosnih koeficijenata\* koji se koriste na ramovima prozora i roletna minimalna snaga koju motor treba imati je (17.17 Nm x 2) 35 Nm.

\* ukupan koeficijent sigurnosti = 2

Tablica 1. Relativne težine i debljina sjenila

Tip sjenila	kg/m <sup>2</sup>	*N/m <sup>2</sup>	debljina sjenila
SP-10	14.25	140	8 mm
SP-20	10.30	101	8 mm
SP-50	7.64	75	8 mm

\*1 kg = 9.81 N

Napomena:

Strogo se preporučava da se tubularni motor ne predimensionira ili poddimensionira

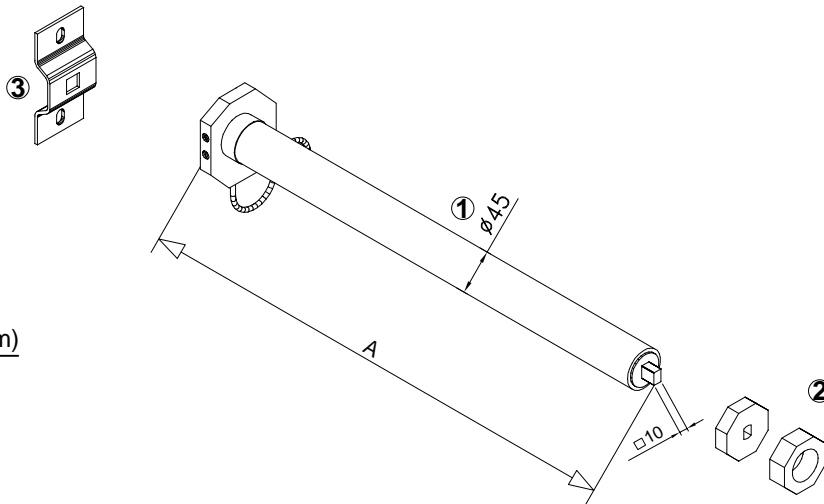

Mod.	A (mm)
20	628
20/26	698
30	698
50	698

① Aprimatic motor za roletne

Opis (Motor sa ručkom za manuelno otvaranje)	Max. težina	Snaga	Potrošnja	Oznaka
45M-20	Ø60 mm / 35 kg	20 Nm	145 W	43310/005
45M-30	Ø60 mm / 55 kg	30 Nm	170 W	43310/006
45M-50	Ø60 mm / 88 kg	50 Nm	191 W	43310/007
45M-20/26	Ø60 mm / 35 kg	20 Nm	191 W	43310/008

②

Adapter za osovinu Ø60 (oktogonalni)	43380/156
--------------------------------------	-----------

③

Nosač motora	43380/084
--------------	-----------

Ručka za manuelno otvaranje	43380/096
-----------------------------	-----------

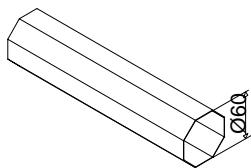

43380/094 ..... OKTOGONALNA CIJEV Ø60 ..... L=3 m  
(Aprimatic)

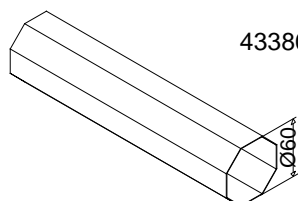
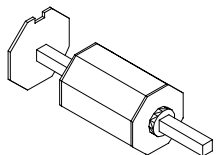

43380/097 ..... PRIHVATNIK ZA OSOVINU Ø60

NAPOMENA: M verzija motora sa mogućnošću ručnog upravljanja u slučaju nestanka struje.

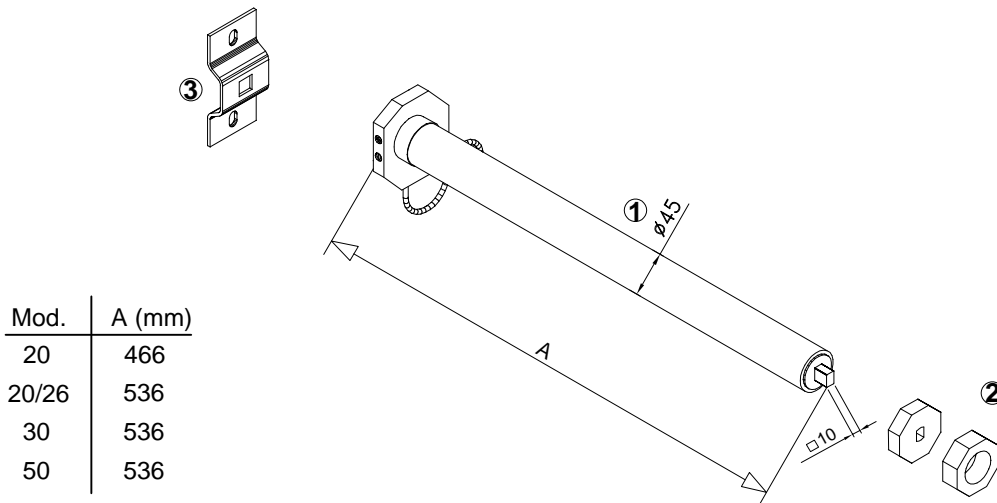

Mod.	A (mm)
20	466
20/26	536
30	536
50	536

### ① Aprimatic motor za roletne

Opis (Motor bez ručke za manuelno otvaranje)	Max. težina	Snaga	Potrošnja	Oznaka
45S-20	Ø60 mm / 35 kg	20 Nm	145 W	43302/001
45S-30	Ø60 mm / 55 kg	30 Nm	170 W	43302/002
45S-50	Ø60 mm / 88 kg	50 Nm	191 W	43302/003
45S-20/26	Ø60 mm / 35 kg	20 Nm	191 W	43302/004

### ②

Adapter za osovinu Ø60 (oktogonalni)	43380/156
--------------------------------------	-----------

### ③

Nosač motora	43380/084
--------------	-----------

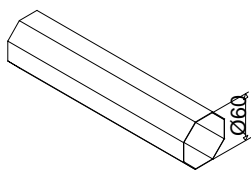

43380/094 ..... OKTOGONALNA CIJEV Ø60 ..... L=3 m  
(Aprimatic)

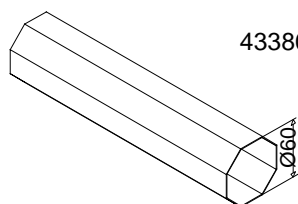
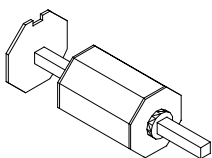

43380/097 ..... PRIHVATNIK ZA OSOVINU Ø60

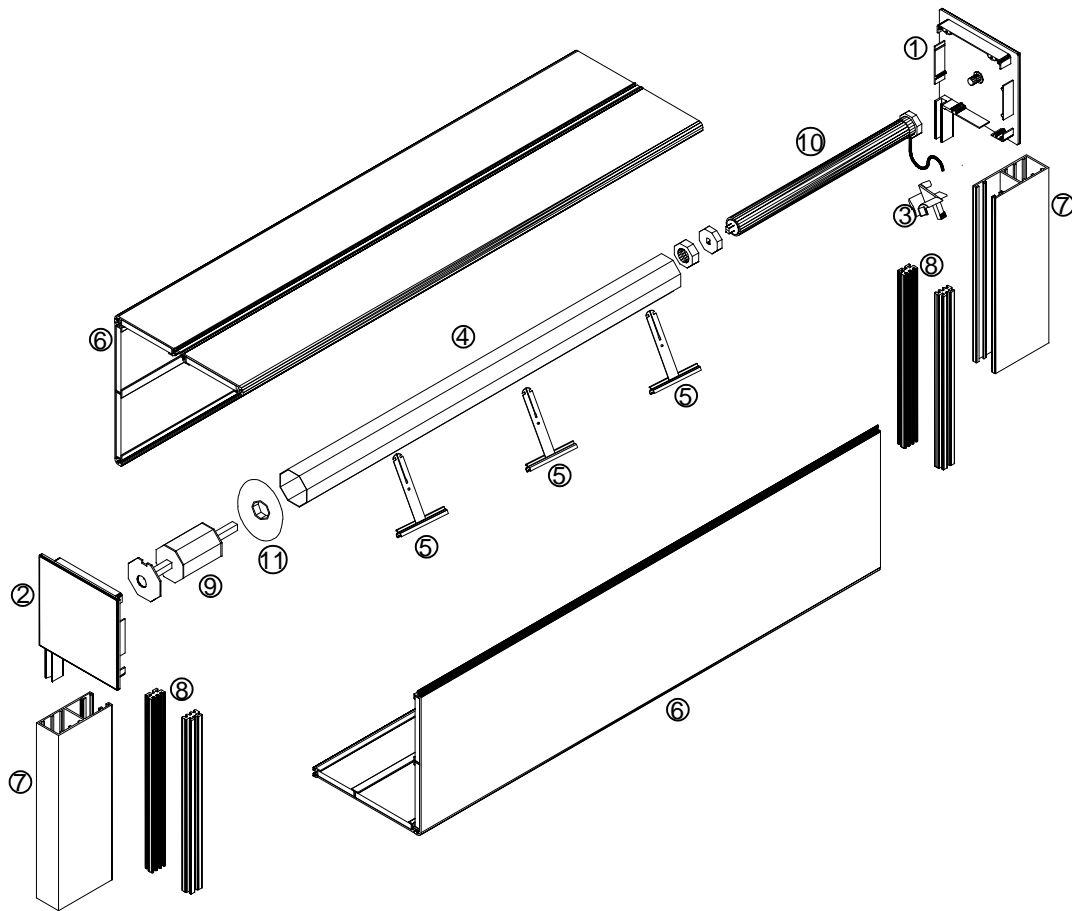

1	..... poklopac kutije (desni)	..... par (lijevi+desni)
2	..... poklopac kutije (lijevi)	..... par (lijevi+desni)
3	..... uvodnik lamele	..... kom.2
4	..... oktogonalna cijev Ø60	..... kom.1; L=
5	..... prihvatnik lamele	..... kom.L/300
6	..... kutija roletne	..... kom.1; L=
7	..... vodilica	..... kom.2; L=
8	..... dihtung vodilice	..... kom.4; L=
9	..... čep osovine	..... kom.1
10	..... Motor D.45 sa adapterom za osovinu Ø60	..... kom.1
11	..... lim umjesto čepa	..... kom.2

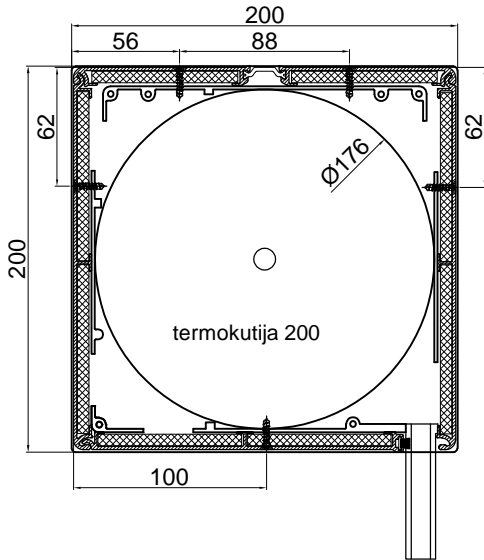

Maksimalna visina prozora	
SP-10	1500 mm
SP-20	1750 mm
SP-50 (18 mm)	900 mm
SP-50 (30 mm)	1000 mm

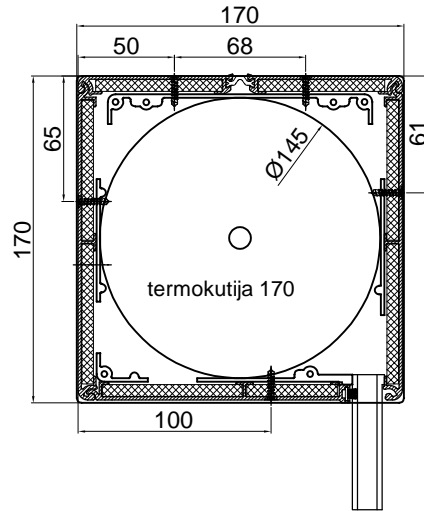

Maksimalna visina prozora	
SP-10	900 mm
SP-20	900 mm

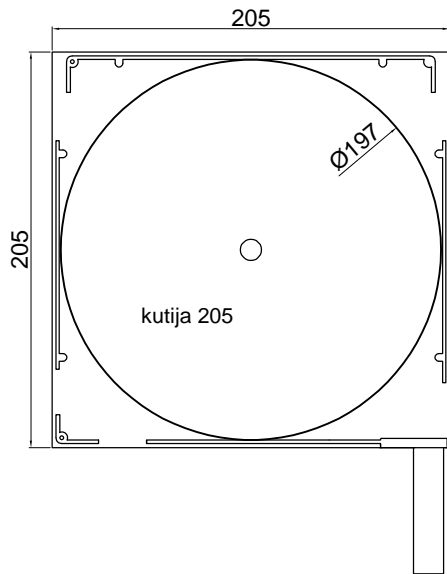

Maksimalna visina prozora	
SP-10	2000 mm
SP-20	2100 mm
SP-50 (18 mm)	1300 mm
SP-50 (30 mm)	1250 mm

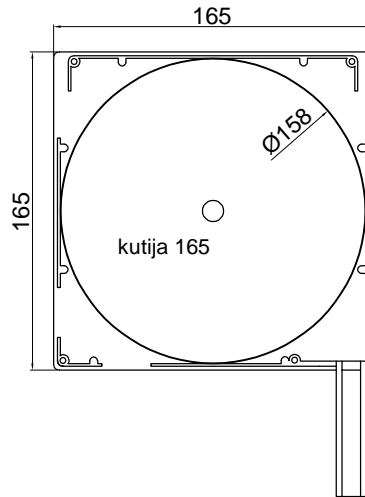

Maksimalna visina prozora	
SP-10	1250 mm
SP-20	1250 mm
SP-50 (18 mm)	750 mm
SP-50 (30 mm)	750 mm

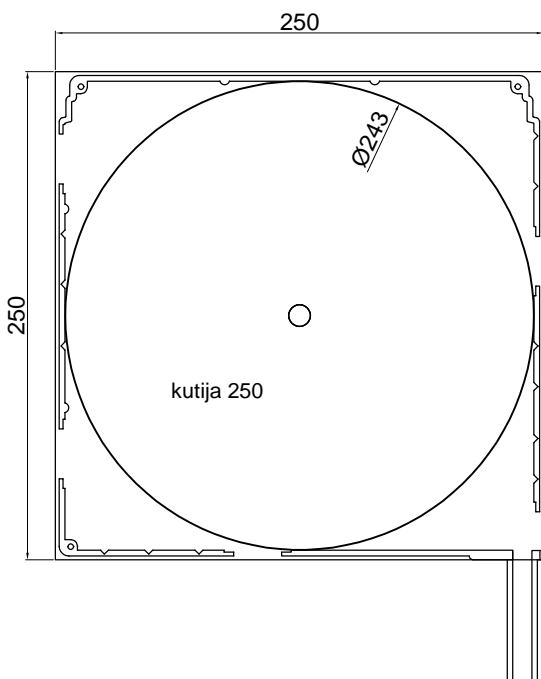

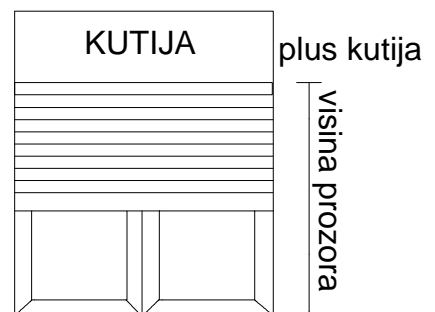

Maksimalna visina prozora	
SP-10	3000 mm
SP-20	3000 mm
SP-50 (18 mm)	2150 mm
SP-50 (30 mm)	2000 mm





Brtve



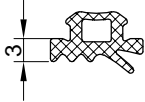
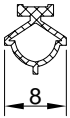

Oznaka	Izgled-presjek	Opis	Materijal	Nap.
344.038		- Brtva za vodilicu - Stara oznaka: P-RV-001		
347.004		- Četkasta brtva 7x5.5 - Stara oznaka PB*HFC	PP	
351.011		- Brtva završne lamele SP-50 - Stara oznaka 02852	EPDM	71 (ShA)
344.014		- Brtva završne lamele SP-10; SP-20 - Stara oznaka: C781-M (art-3866)	TPE	



# Dodaci

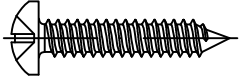
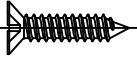

Oznaka	Izgled-presjek	Opis	Materijal	Nap.
433.045		Vijak 4.8x25 DIN 7981		
433.092		Vijak 3.5x16 DIN 7982		
433.203		Vijak 2.9x16 DIN 7982		



# Presjeci



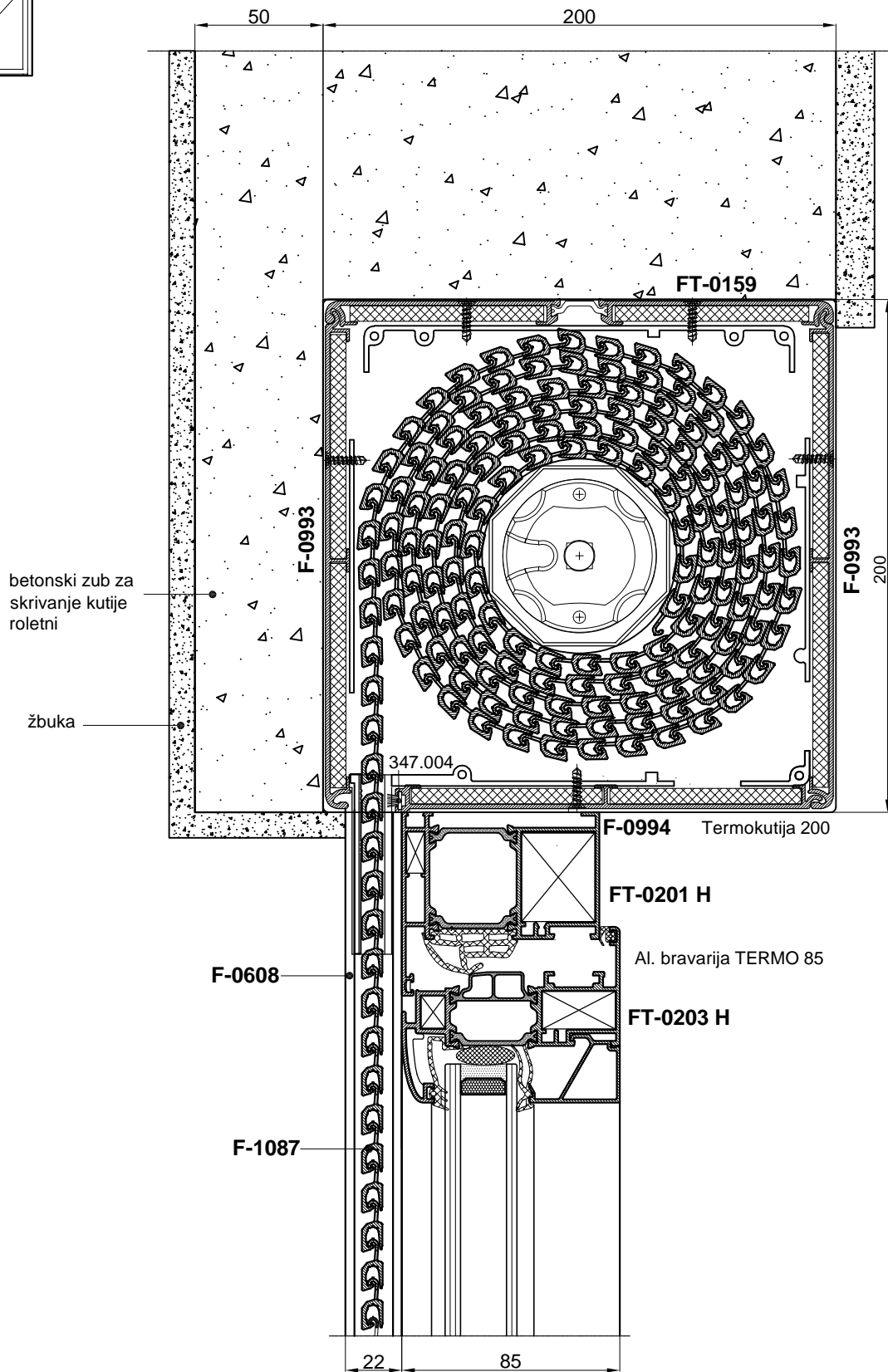
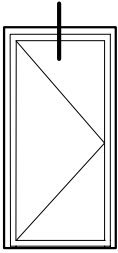

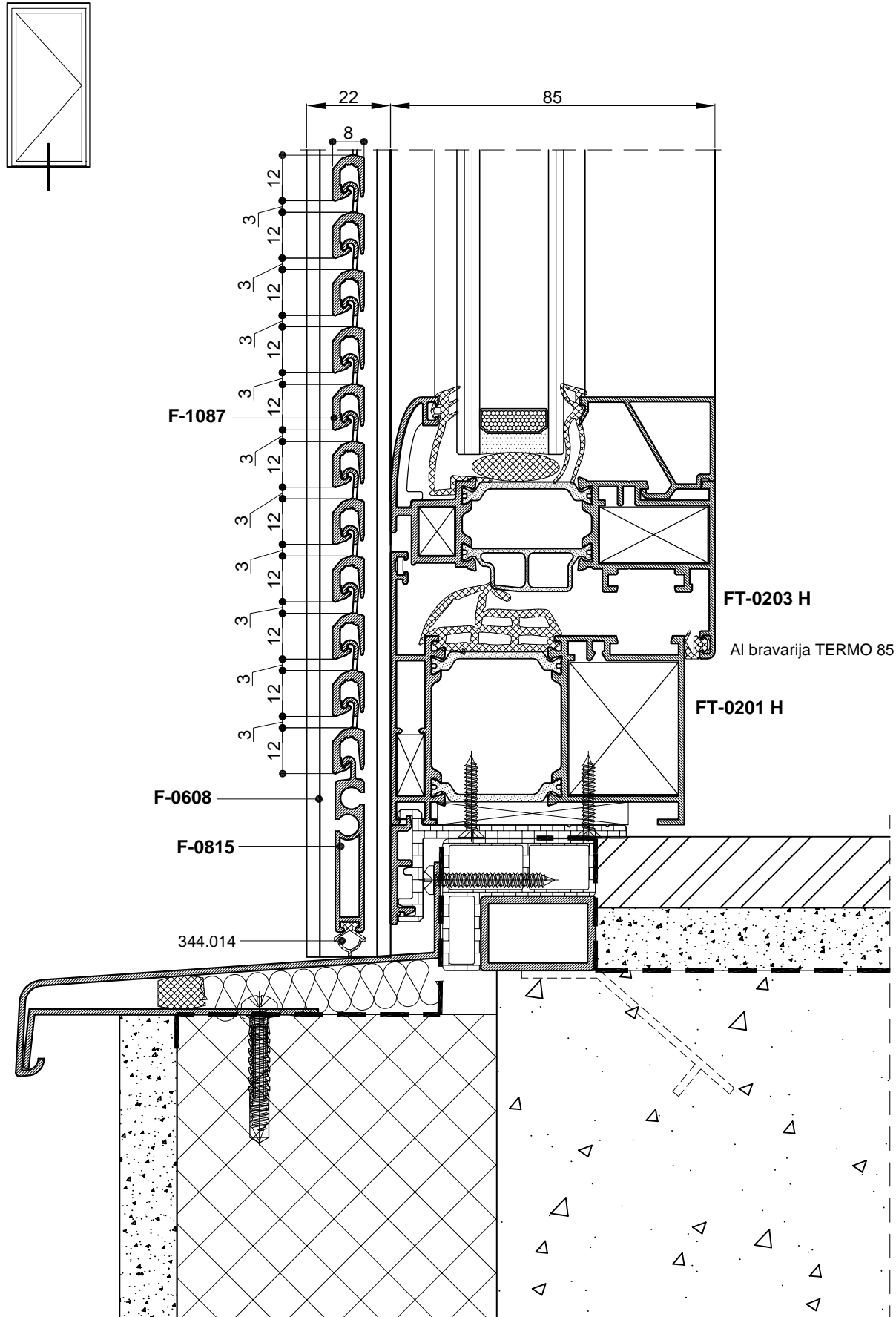

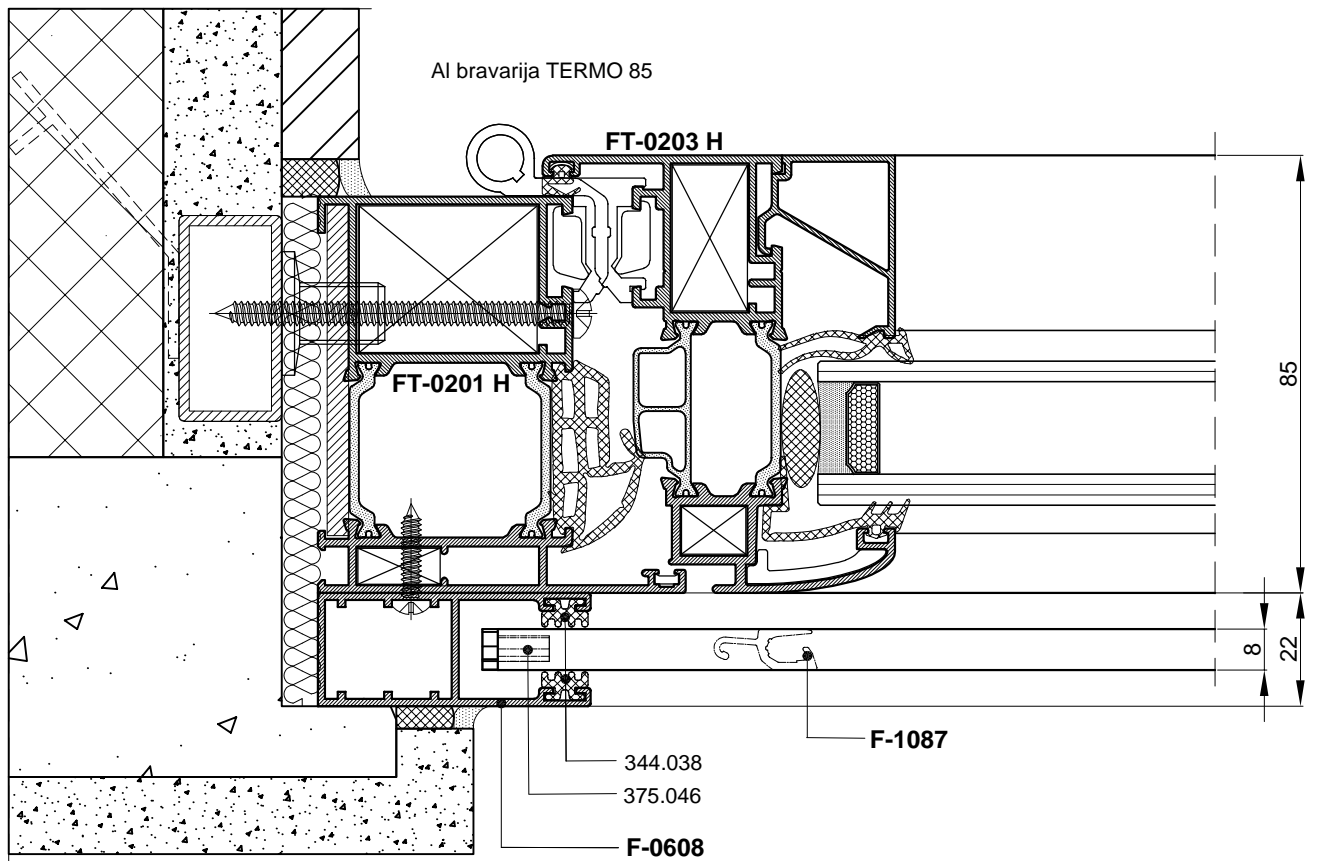
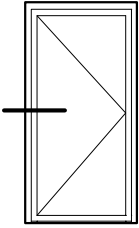

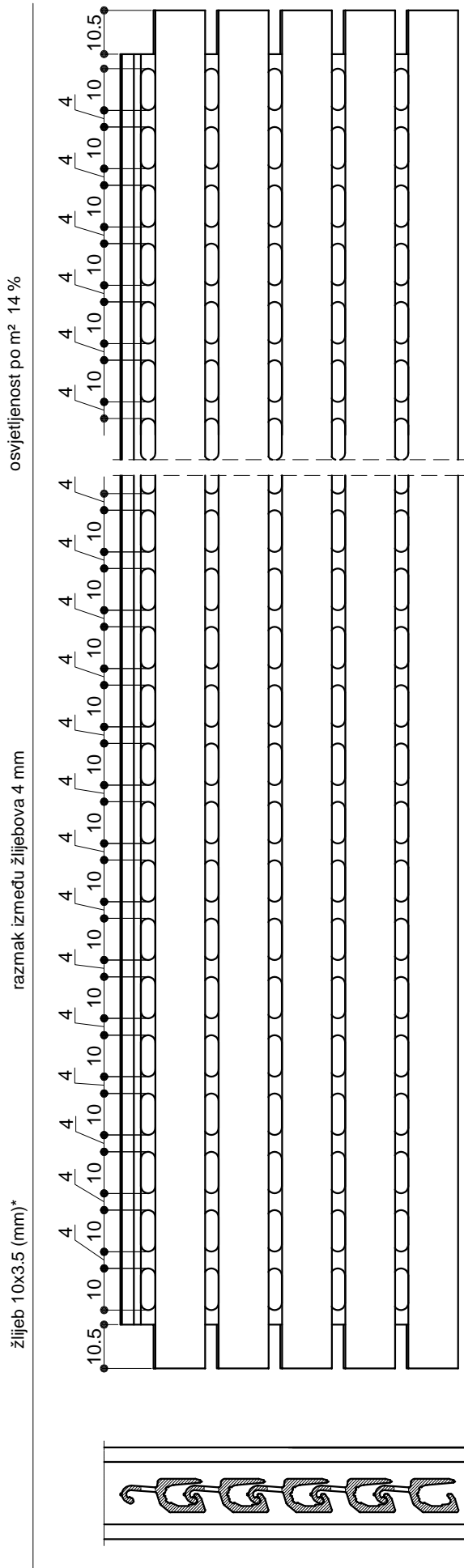

\* lamele se kupcu isporučuju u dužini šipke (L=6500 mm) nakon čega kupac sam vrši obradu (pilanje na zadane dimenzije i obradu krajeva lamele)

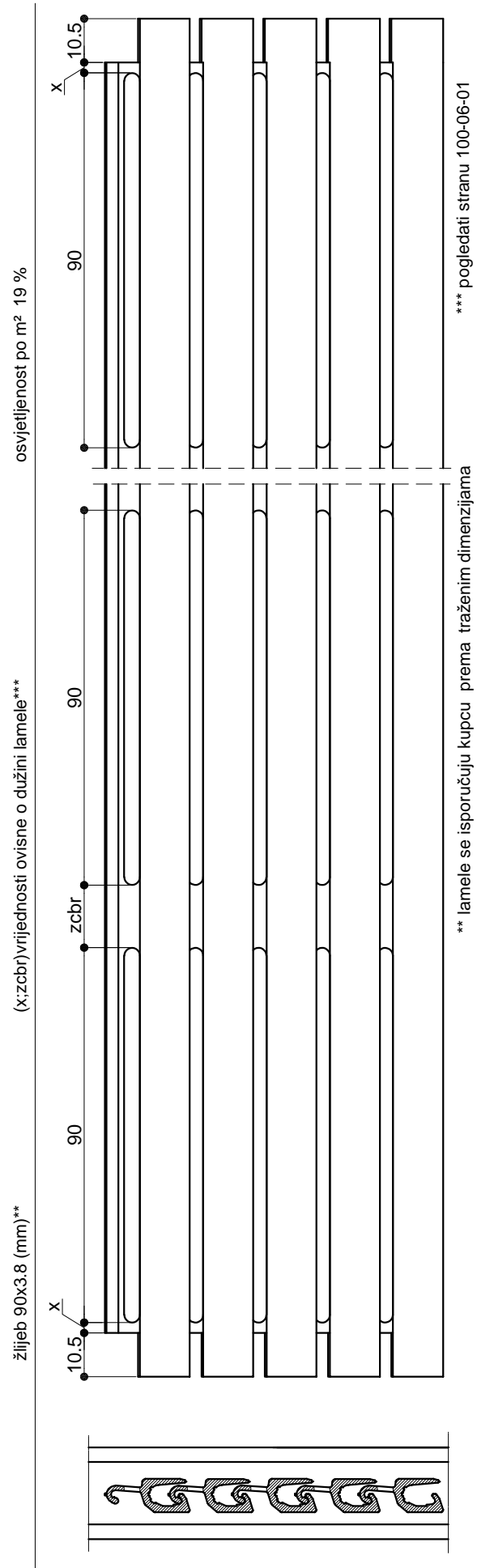

\*\* lamele se isporučuju kupcu prema traženim dimenzijama

\*\*\* pogledati stranu 100-06-01

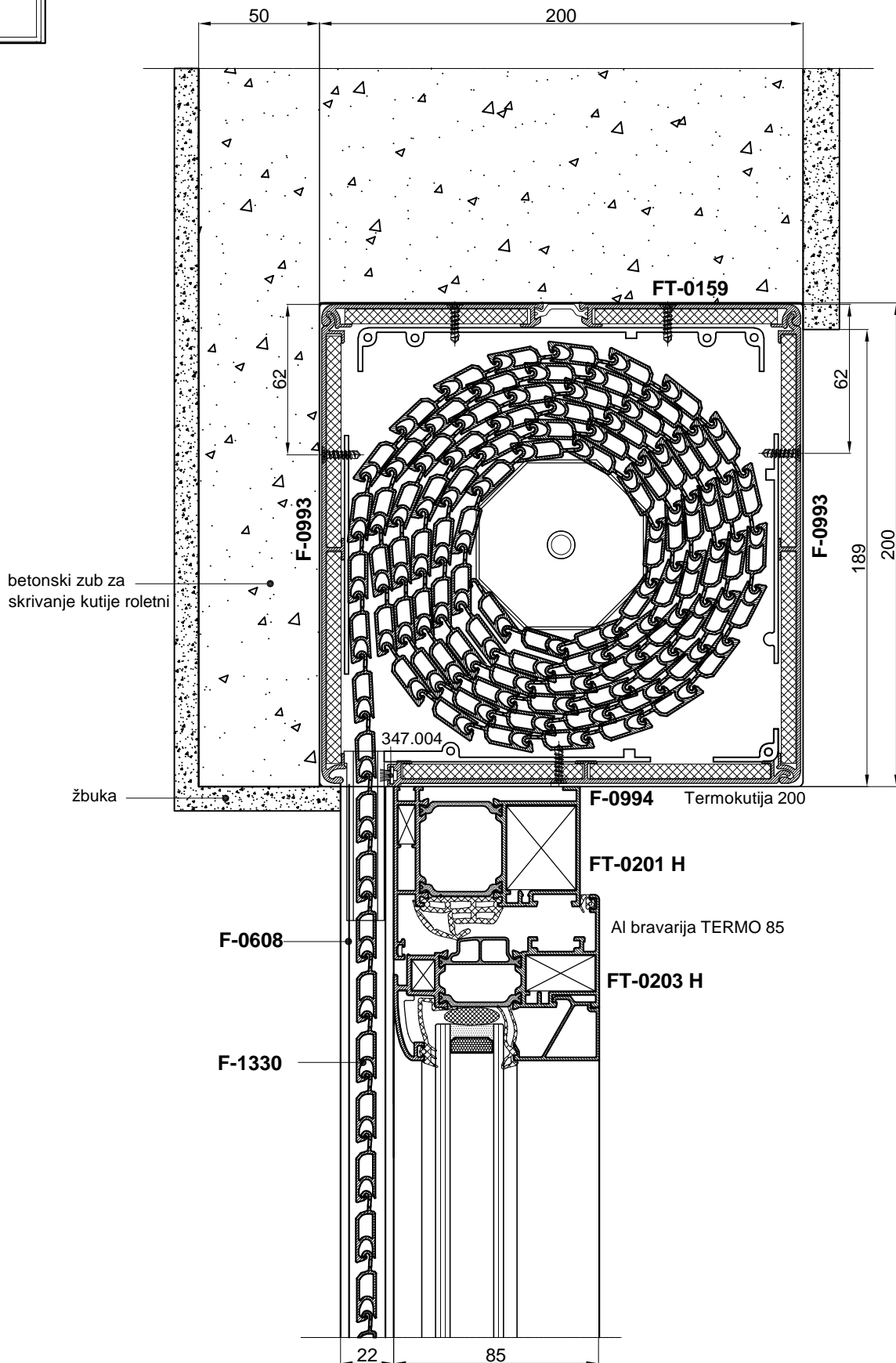
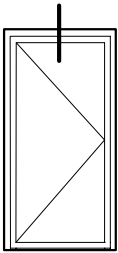

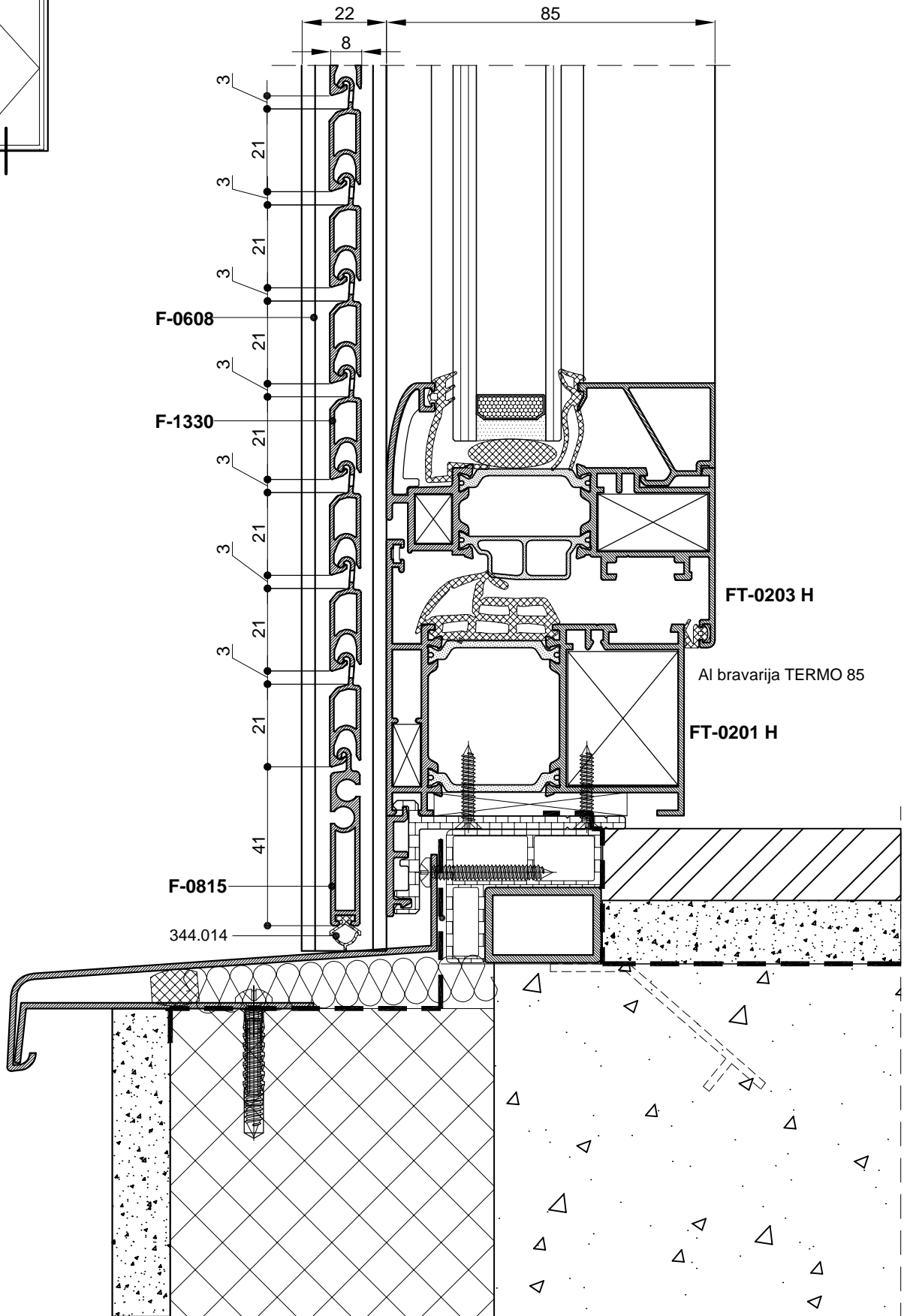
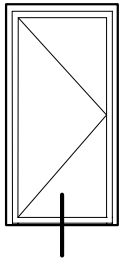

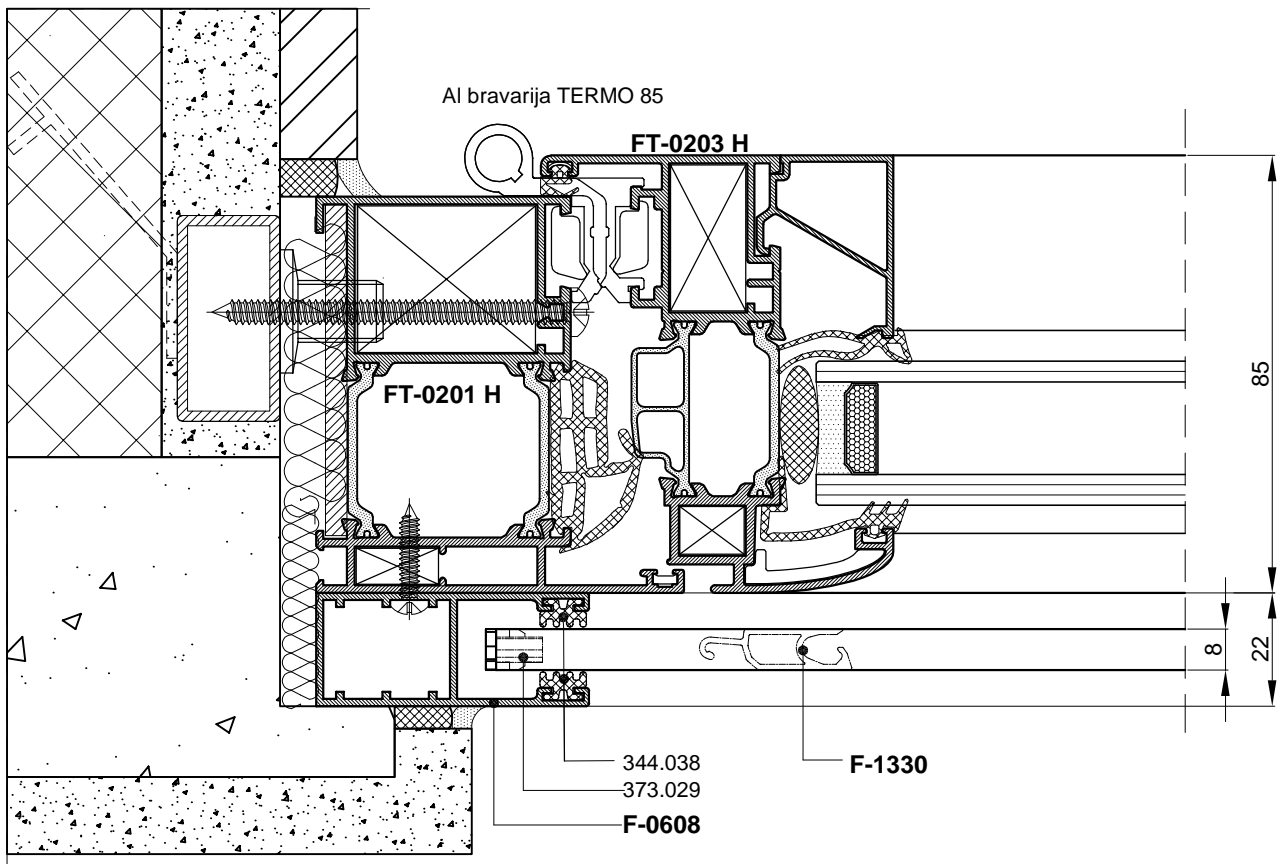
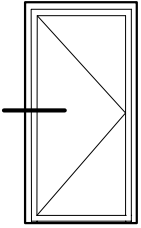

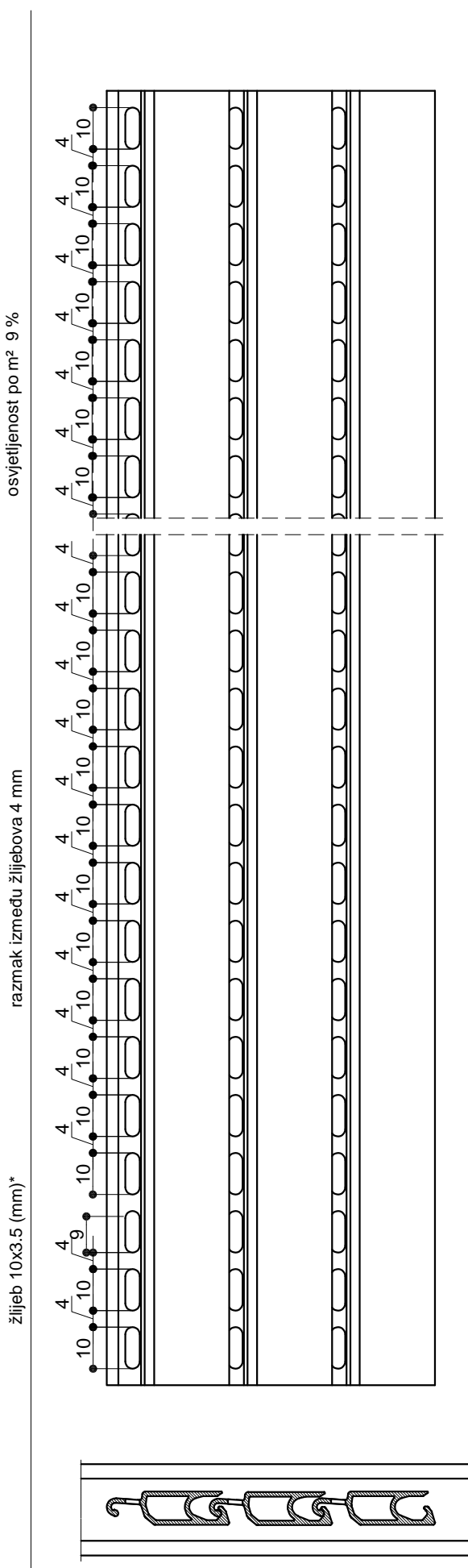

\* lamele se kupcu isporučuju u dužini šipke (L=6500 mm) nakon čega kupac sam vrši pilanje na zadane dimenzije

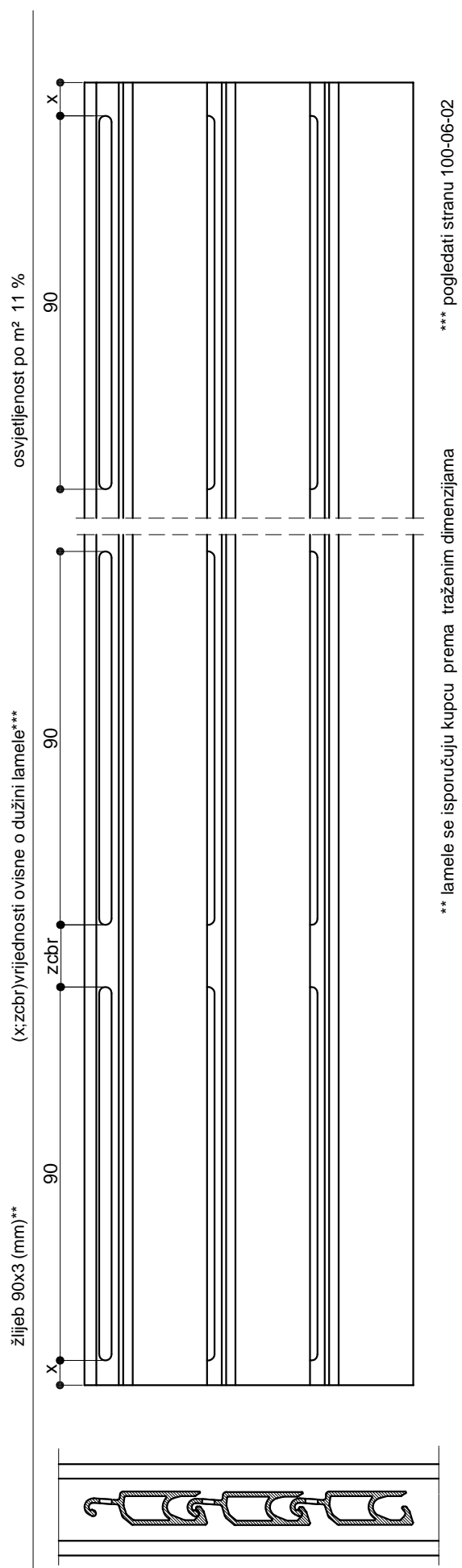

\*\* lamele se isporučuju kupcu prema traženim dimenzijama

\*\*\* pogledati stranu 100-06-02

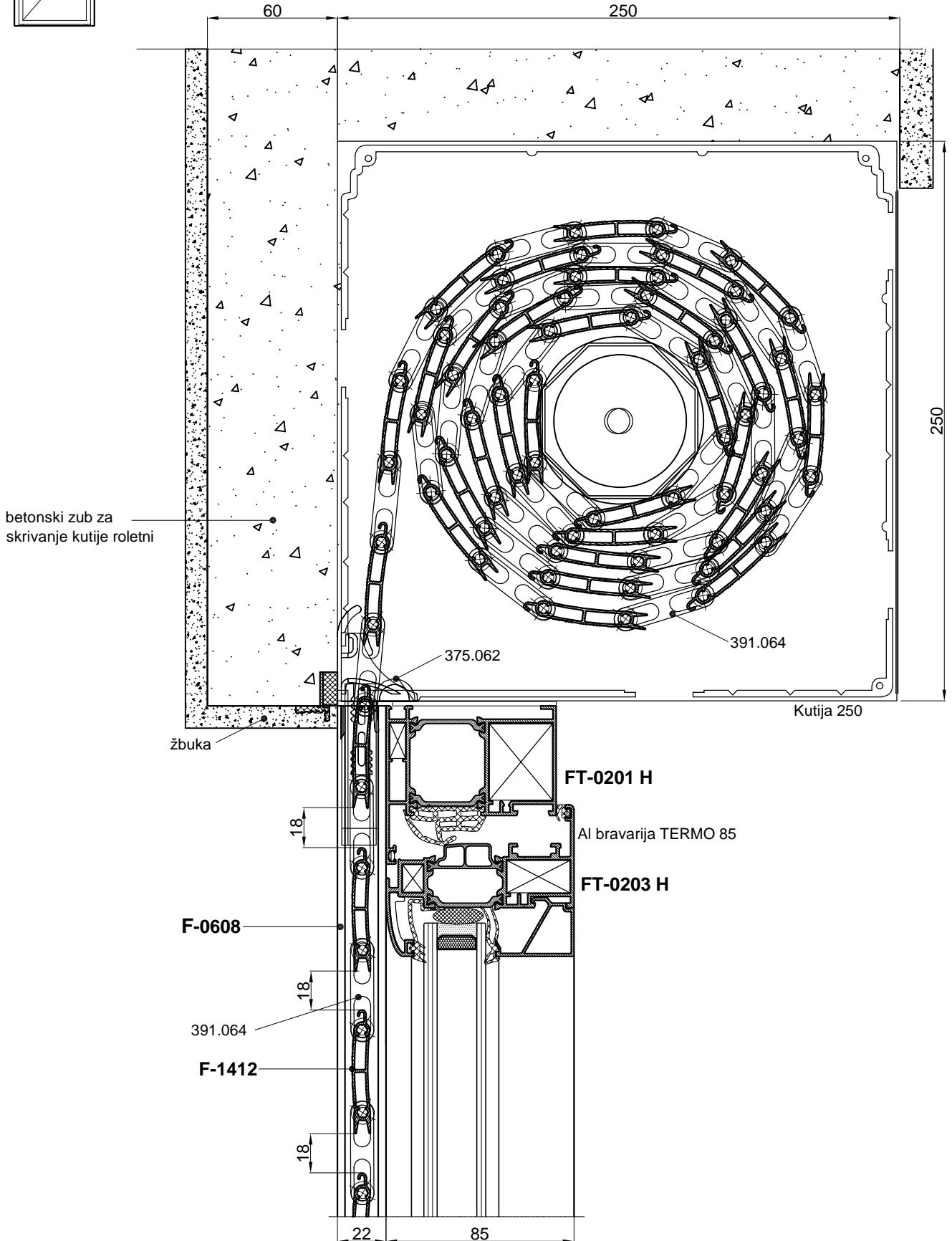
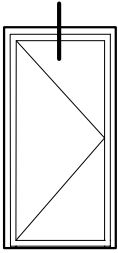

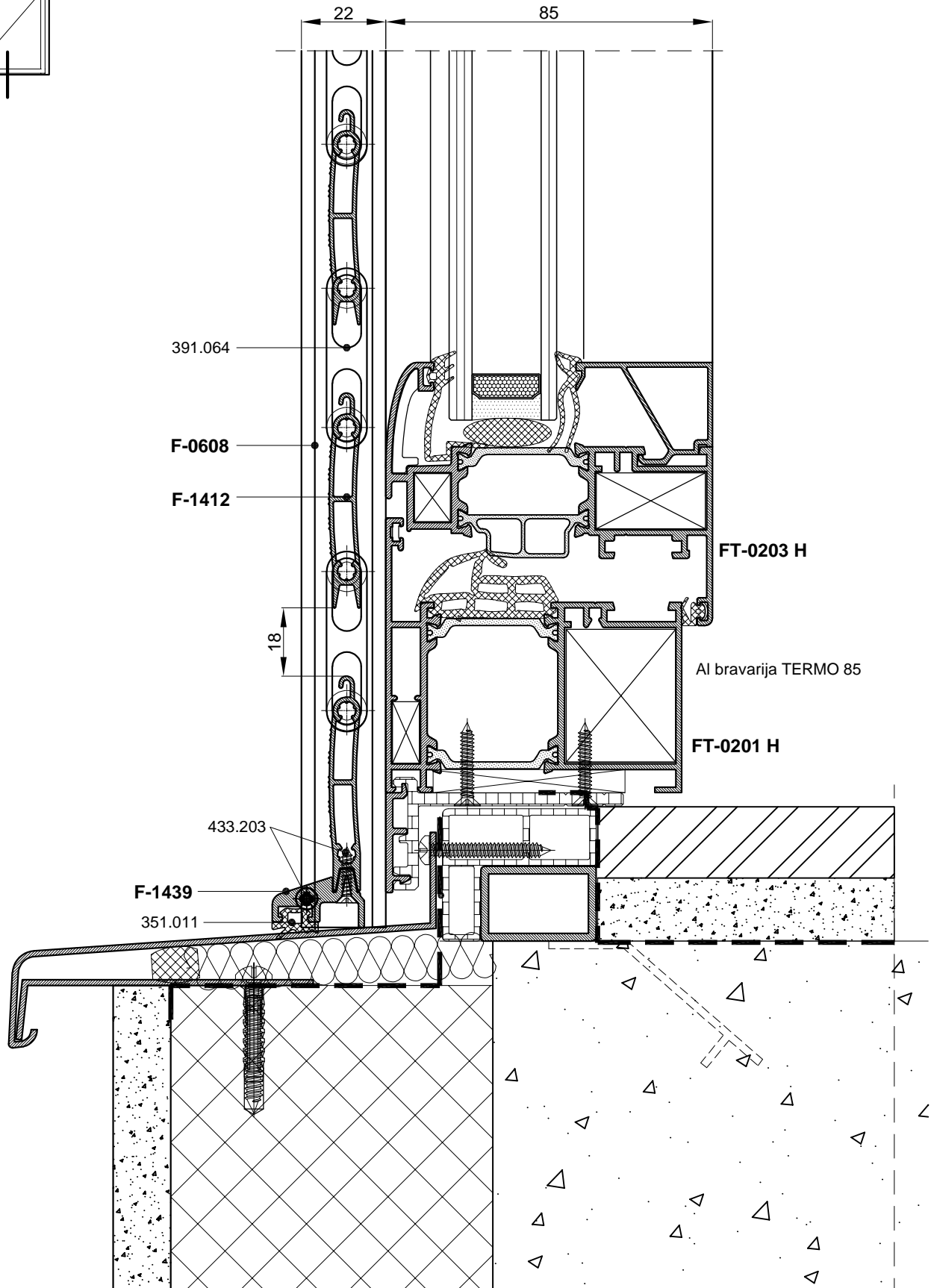
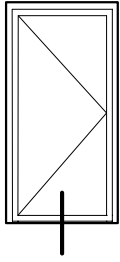

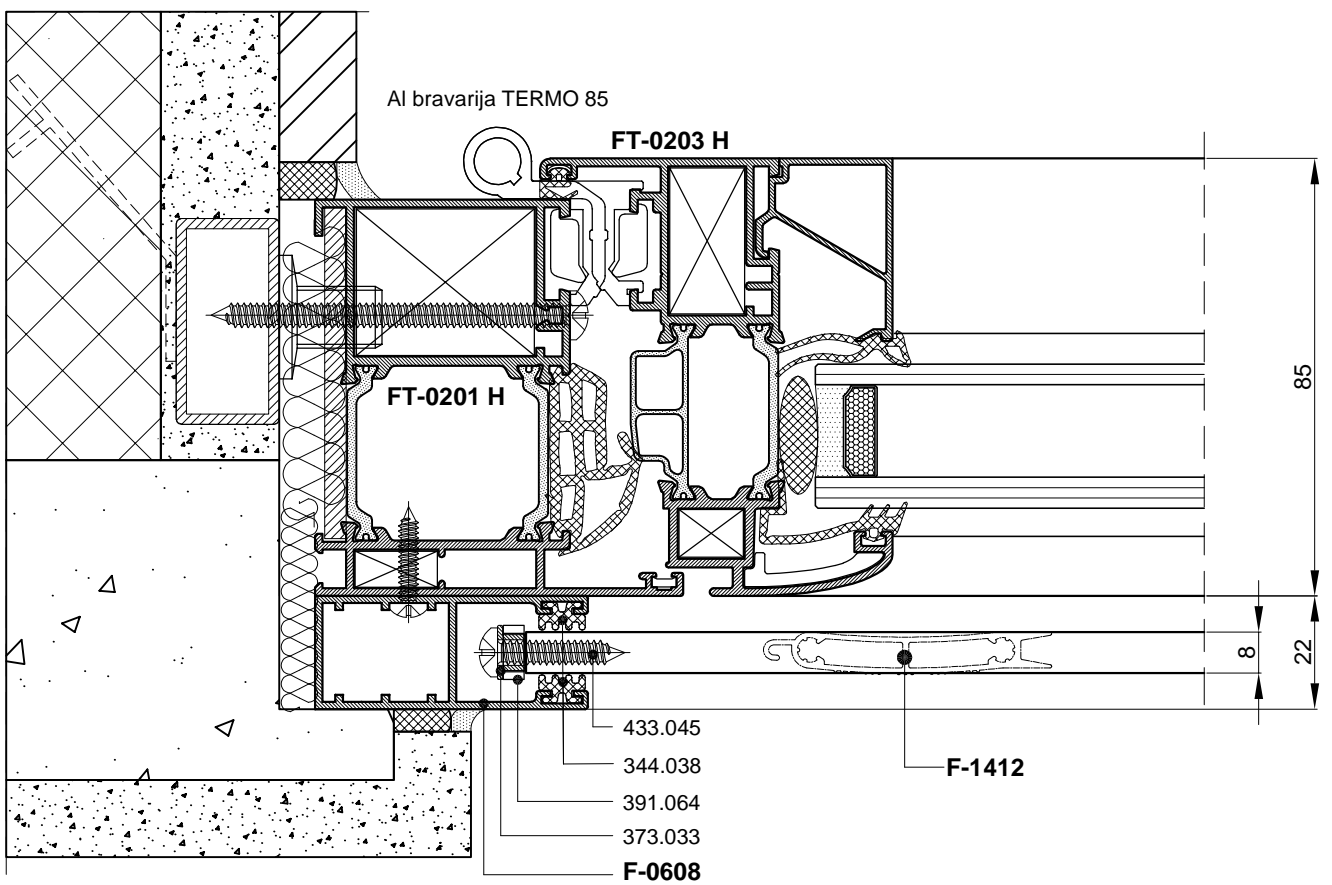
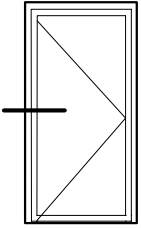

ZATVOREN POLOŽAJ LAMELA

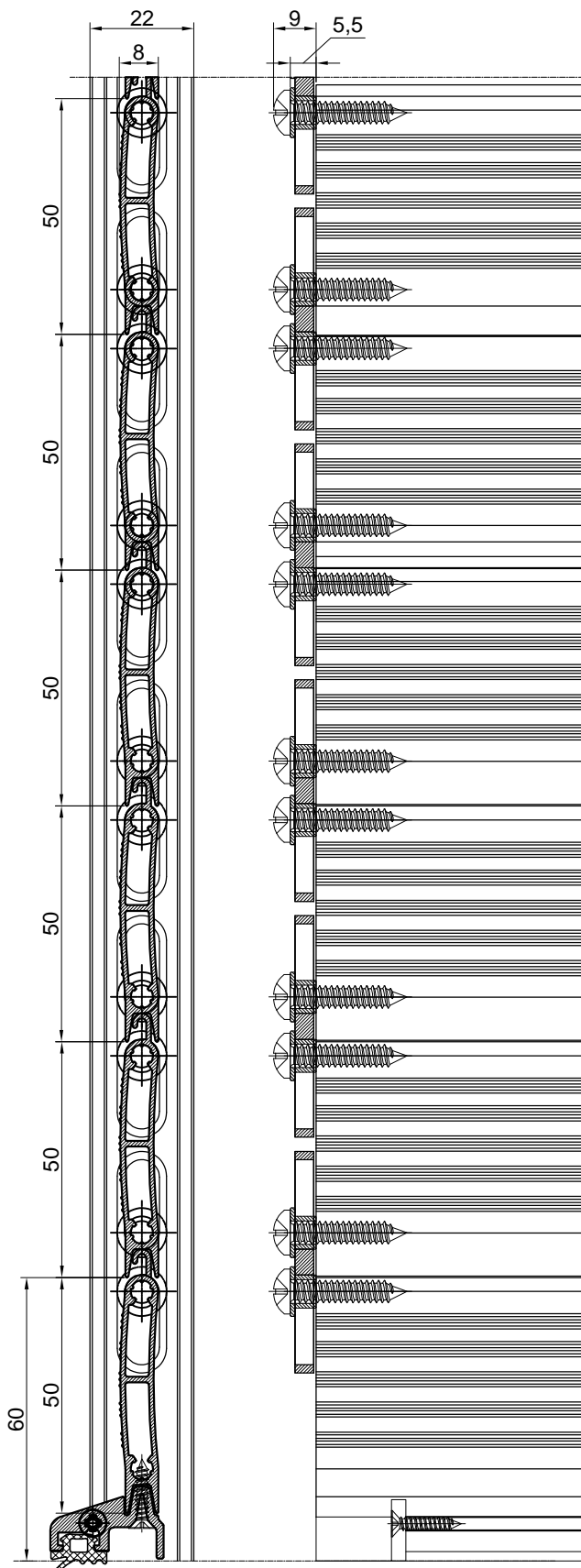

OTVOREN POLOŽAJ LAMELA

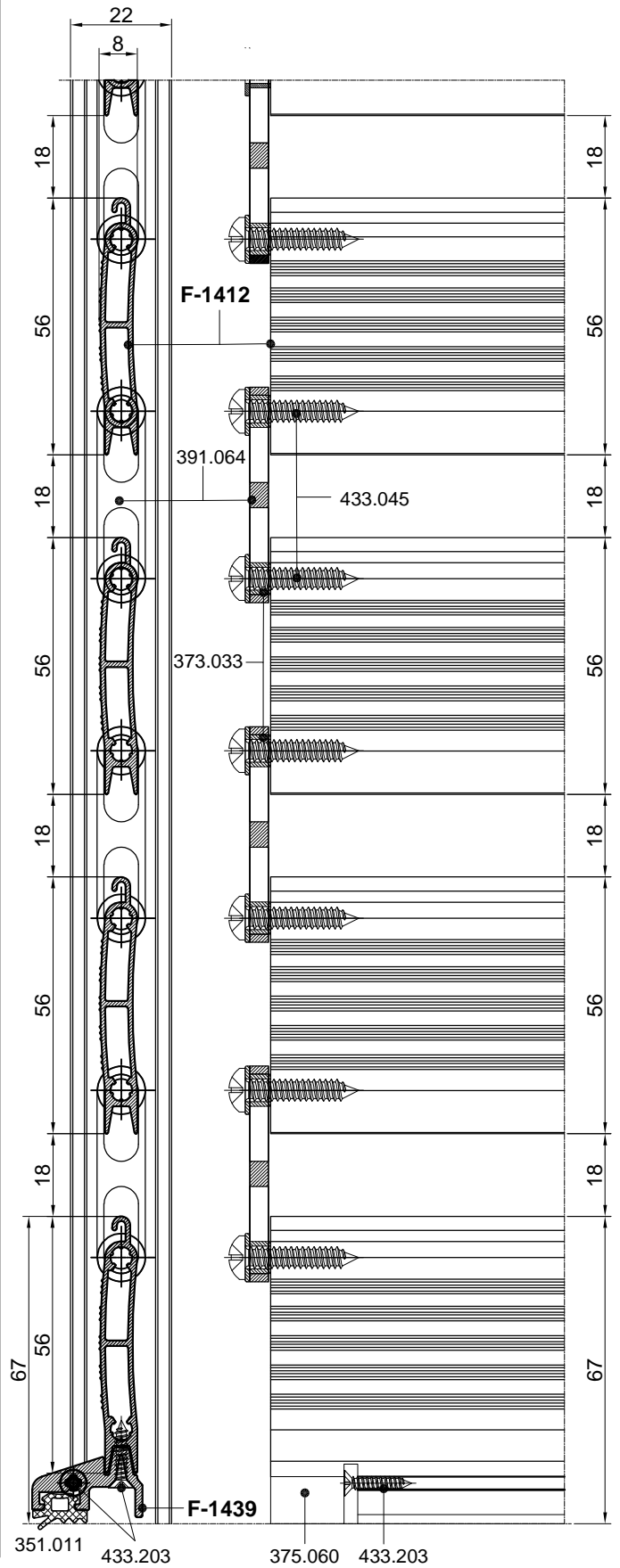

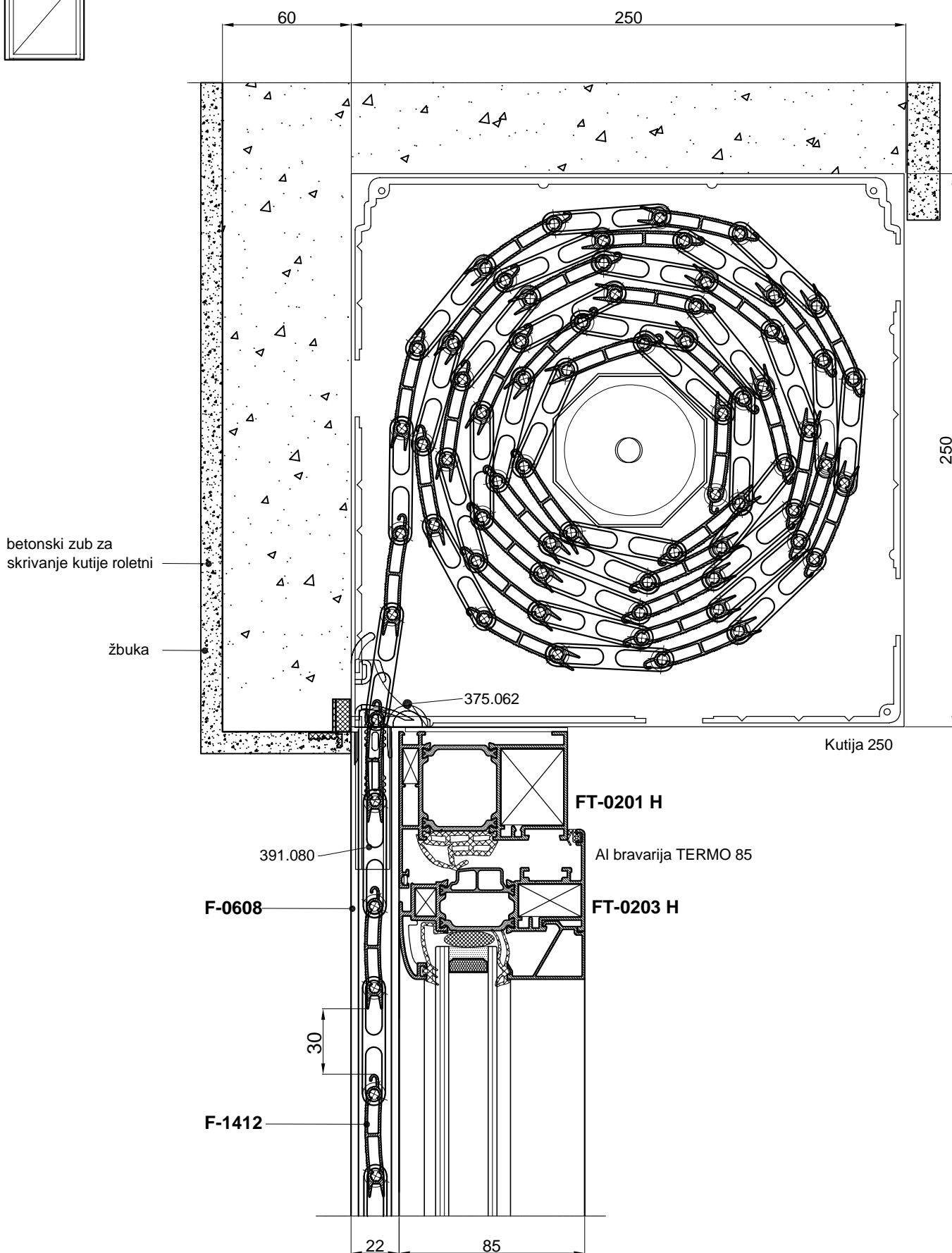
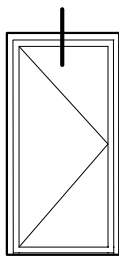

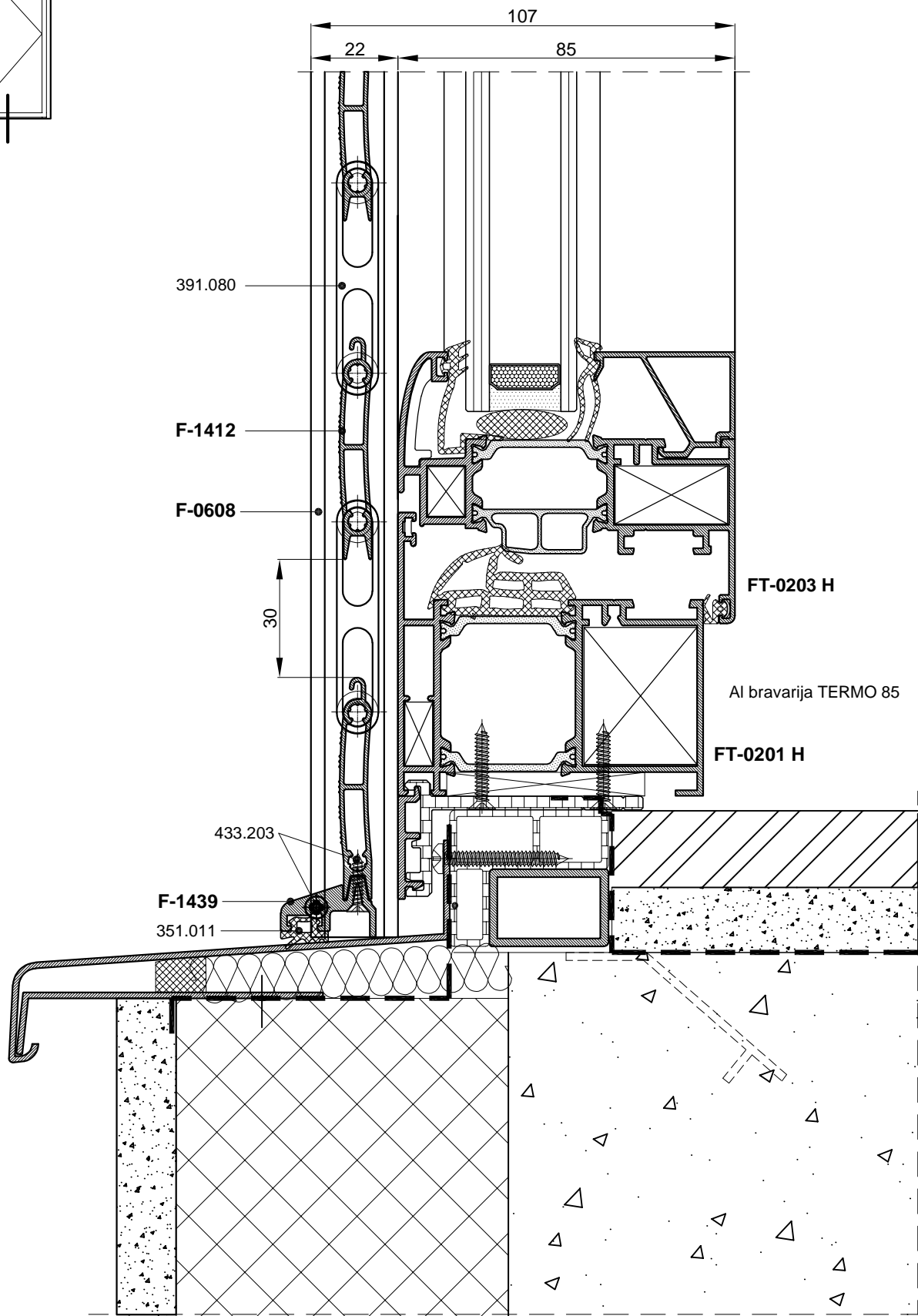
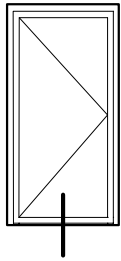

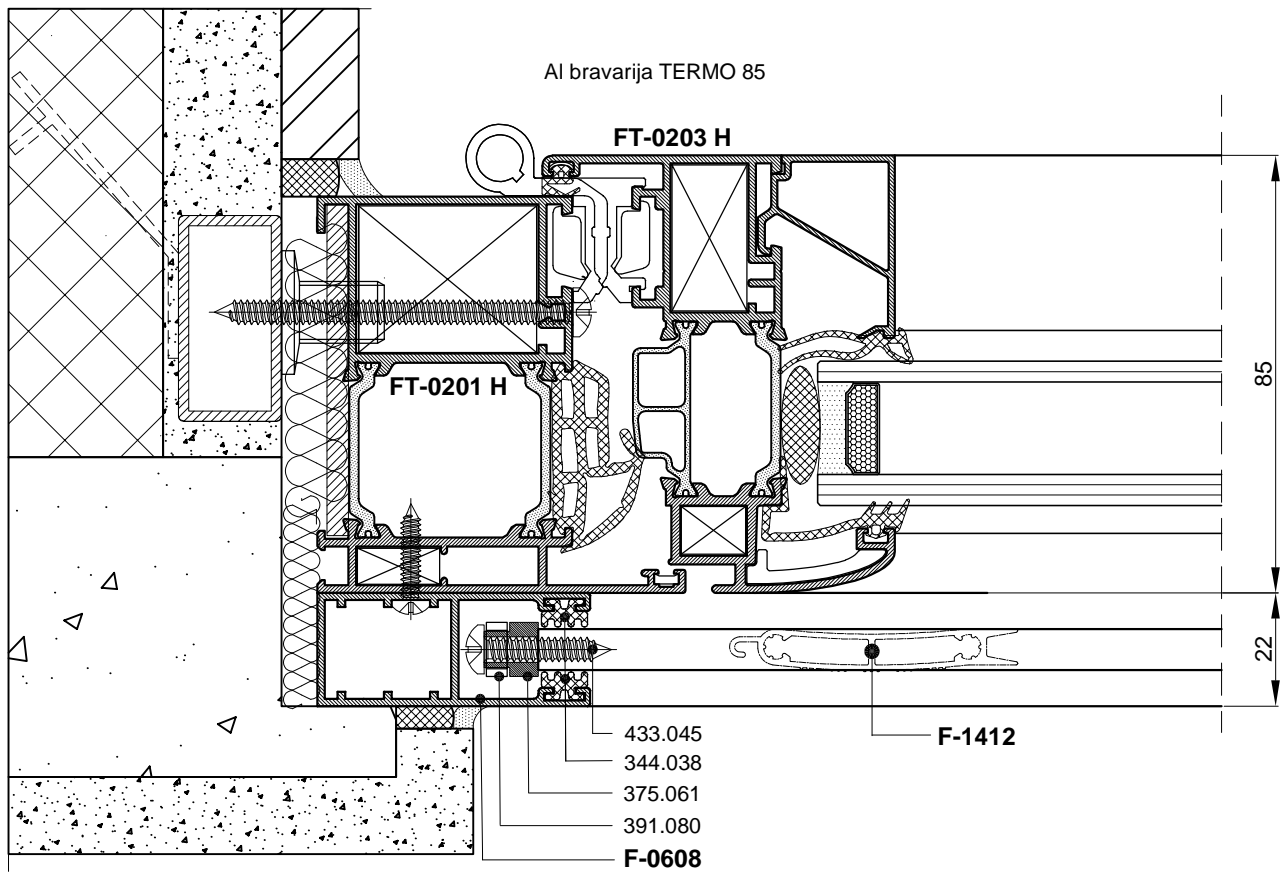
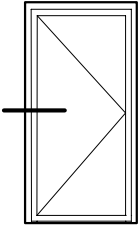

ZATVOREN POLOŽAJ LAMELA

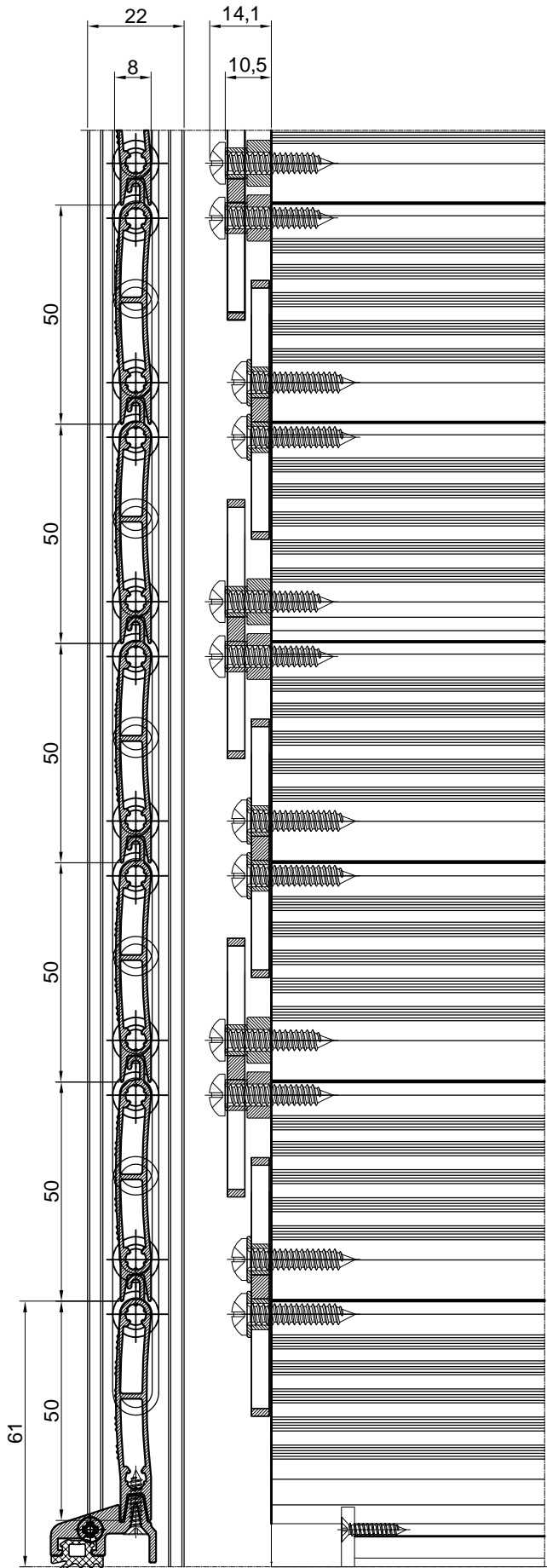

OTVOREN POLOŽAJ LAMELA

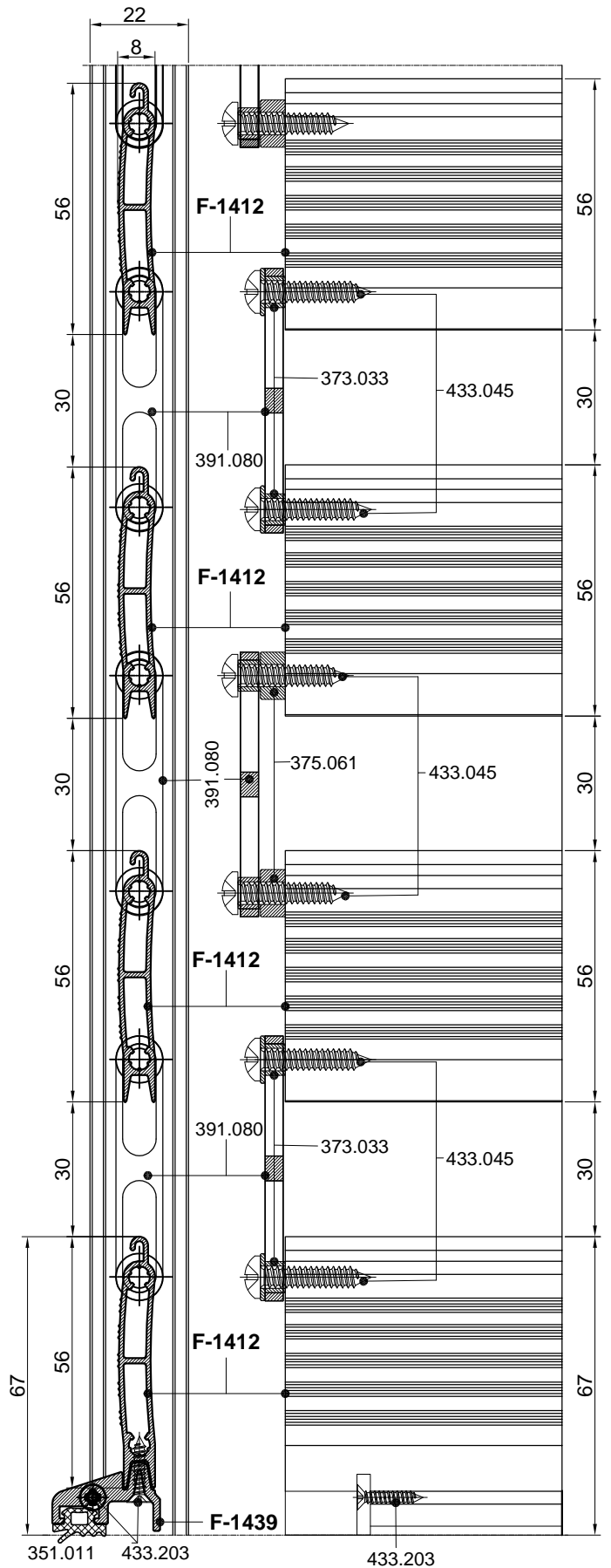

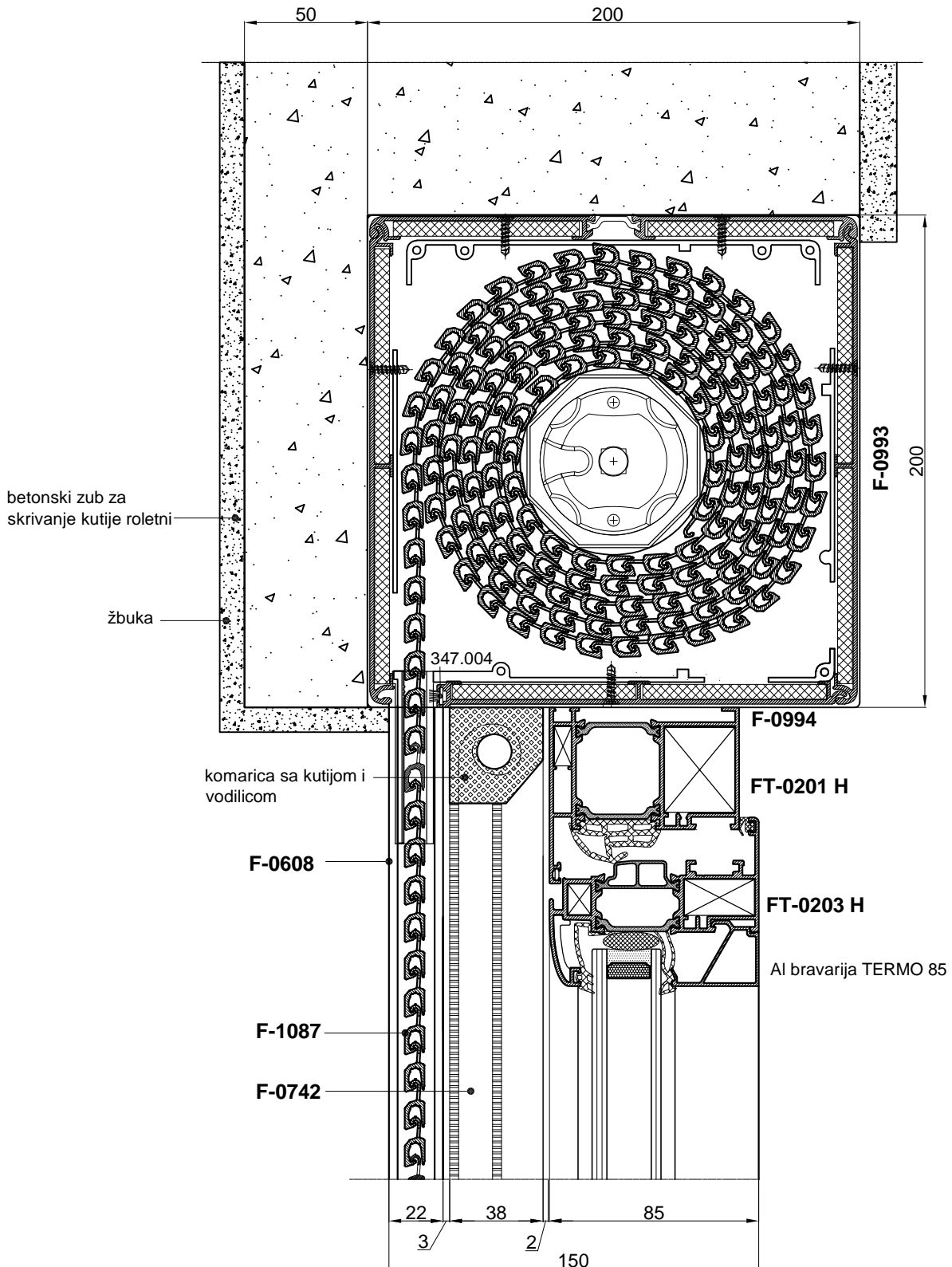
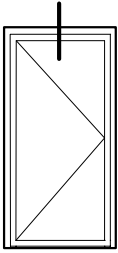

Napomena: ugradnja komarica je moguća i sa SP-20 i sa SP-50

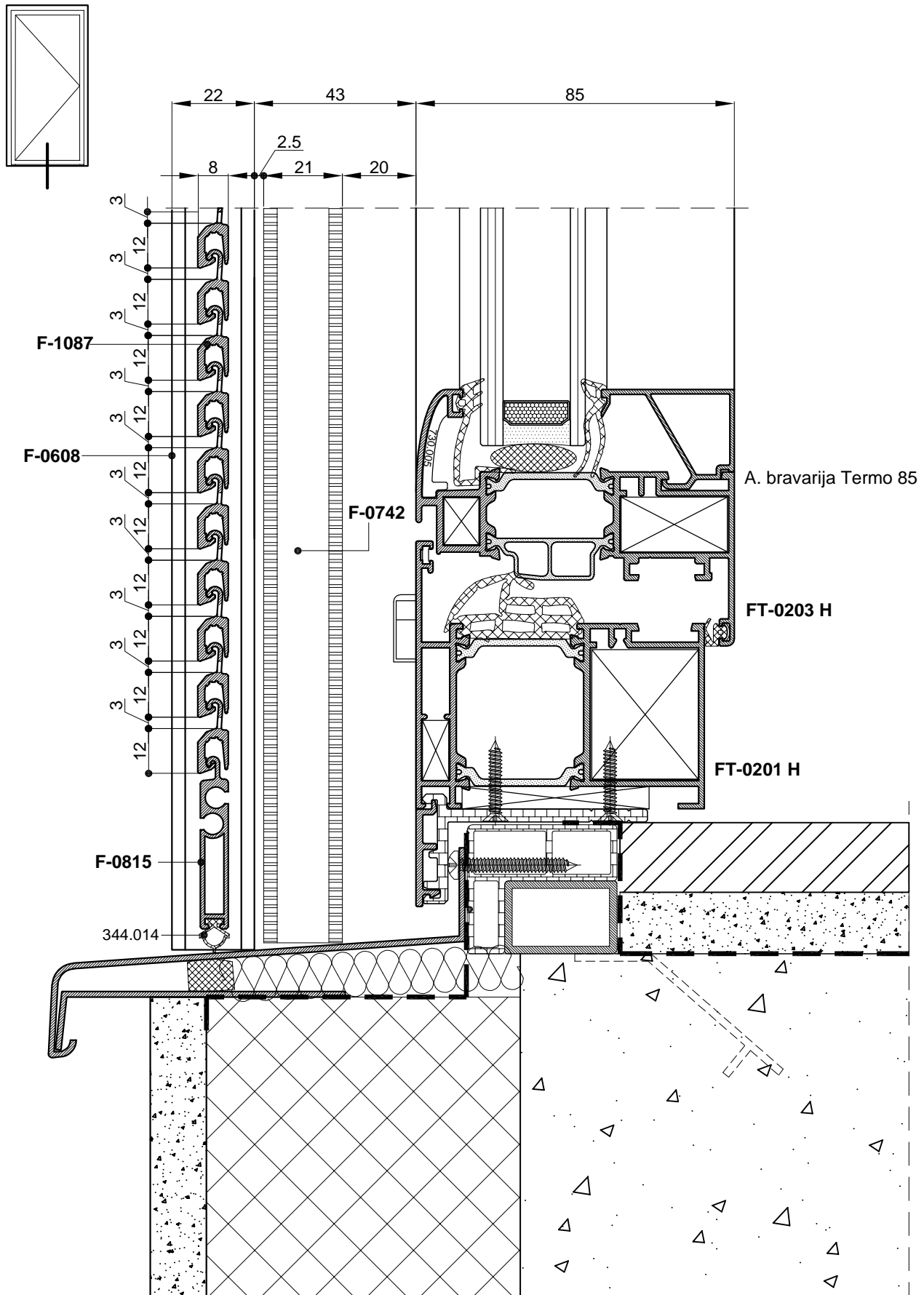

Napomena: ugradnja komarica je moguća i sa SP-20 i sa SP-50

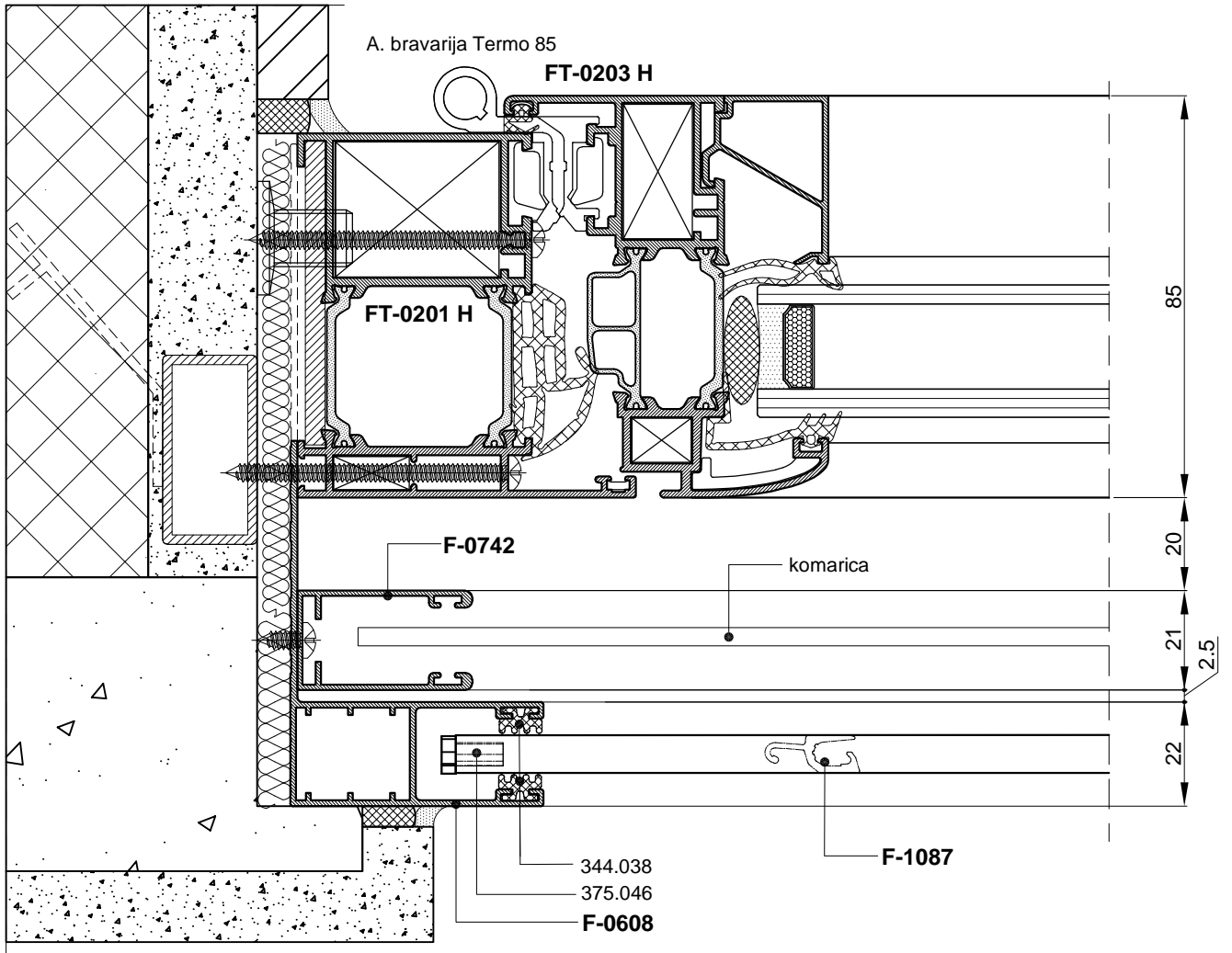
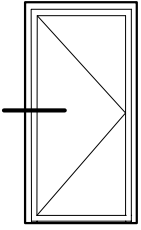

Napomena: ugradnja komarica je moguća i sa SP-20 i sa SP-50

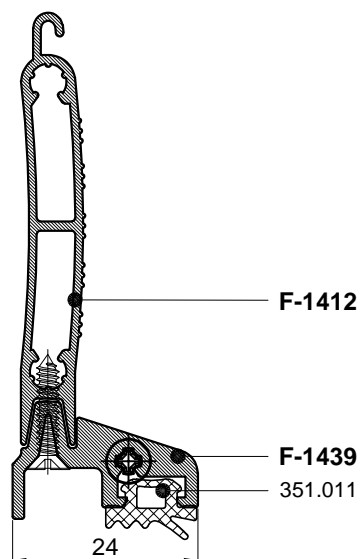
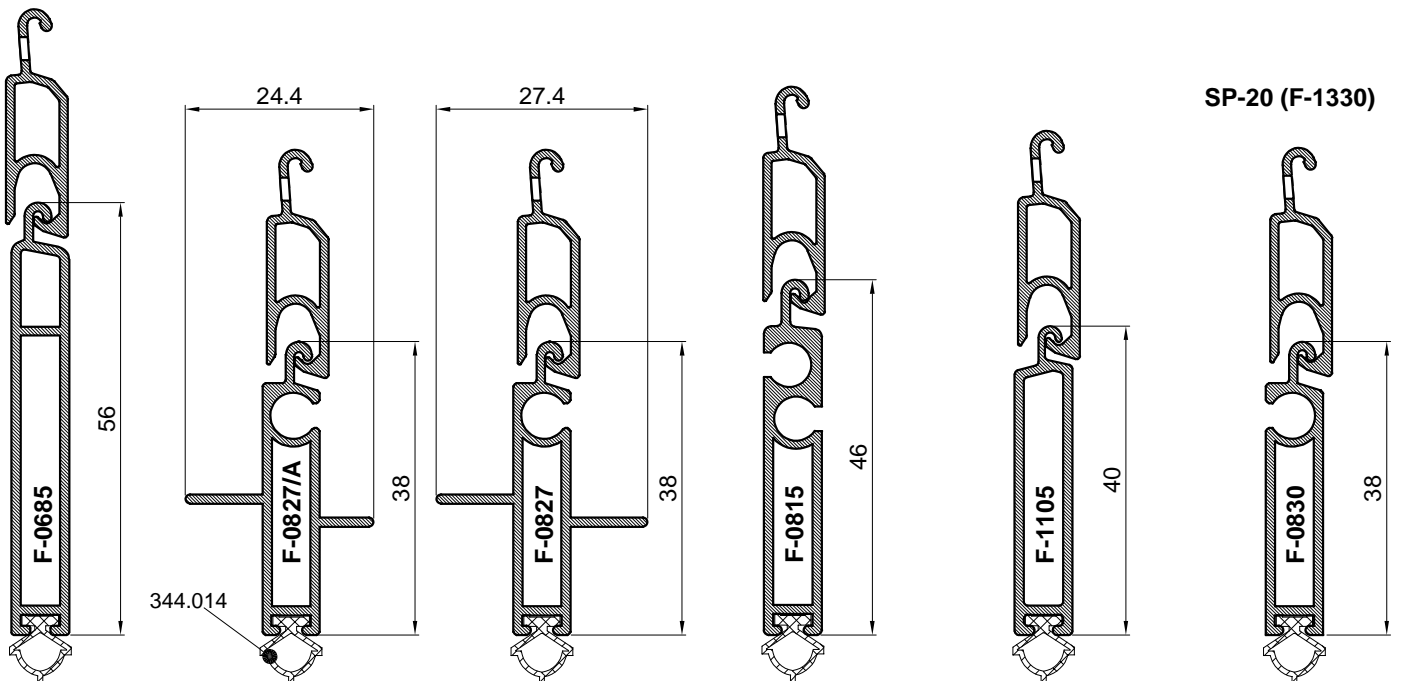
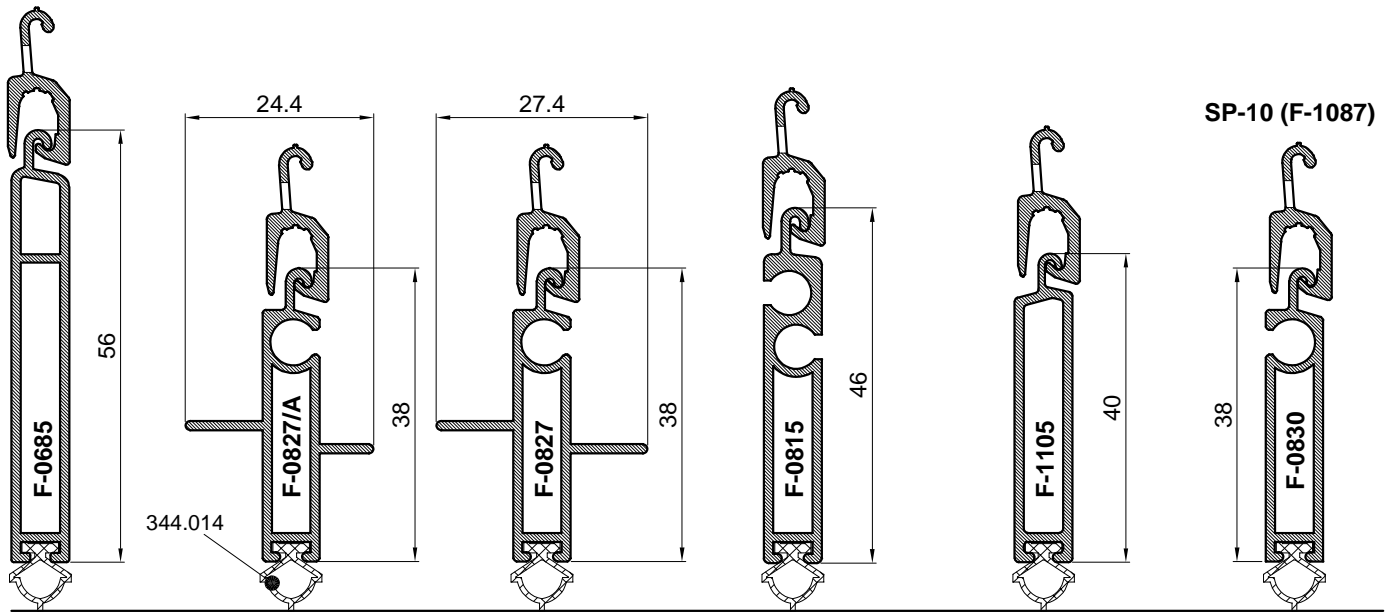

# Obrada i montaža



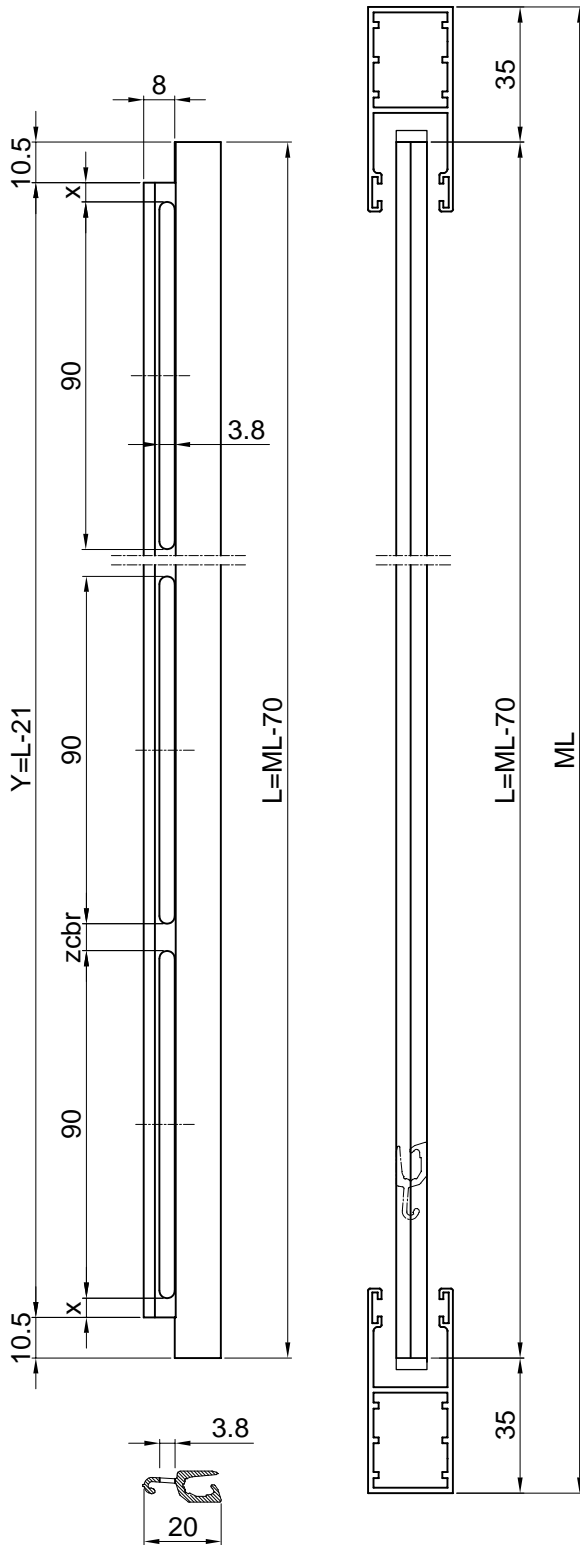

ML=\_\_\_\_\_

L=ML-70=\_\_\_\_\_

Y=L-21=\_\_\_\_\_

Br=L/100 < manji broj =\_\_\_\_\_

Z=(Y-Br x 90) / (Br + 1) =\_\_\_\_\_

Zcbr = prvi manji ili veci cio broj=\_\_\_\_\_

R= Z - Zcbr=\_\_\_\_\_

x=Z + (Rx(Br-1))/2=\_\_\_\_\_

ML - širina između krajeva vodilica (mm)

L - širina lamele F-1087 (mm)

Y - širina lamele sa obrađenim krajevima (mm)  
(mogućnost ugradnje čepova 375.046)

x - udaljenost do početka žljeba 90x3.8 (mm)

Zcbr - razmak između žljebova 90x3.8 (mm)

Br - broj žljebova 90x3.8 na lameli

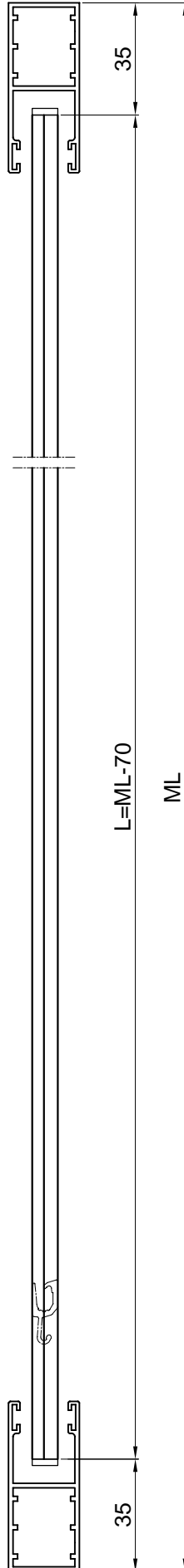
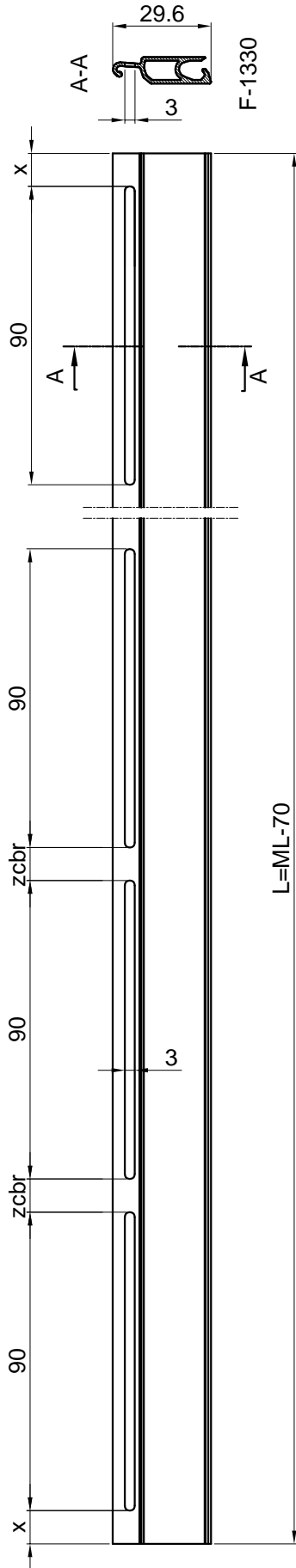

$ML =$  \_\_\_\_\_  
 $L = ML - 70 =$  \_\_\_\_\_  
 $Br = L / 100 < \text{manji broj} =$  \_\_\_\_\_  
 $Z = (L - Br \times 90) / (Br + 1) =$  \_\_\_\_\_  
 $Zcbr = \text{prvi manji ili veci cio broj} =$  \_\_\_\_\_  
 $R = Z - Zcbr =$  \_\_\_\_\_  
 $x = Z + (Rx(Br - 1)) / 2 =$  \_\_\_\_\_

ML - širina između krajeva vodilica (mm)

L - širina lamele F-1330 (mm)

x - udaljenost do početka žljeba 90x3 (mm)

Zcbr - razmak između žljebova 90x3 (mm)

Br - broj žljebova 90x3 na lameli

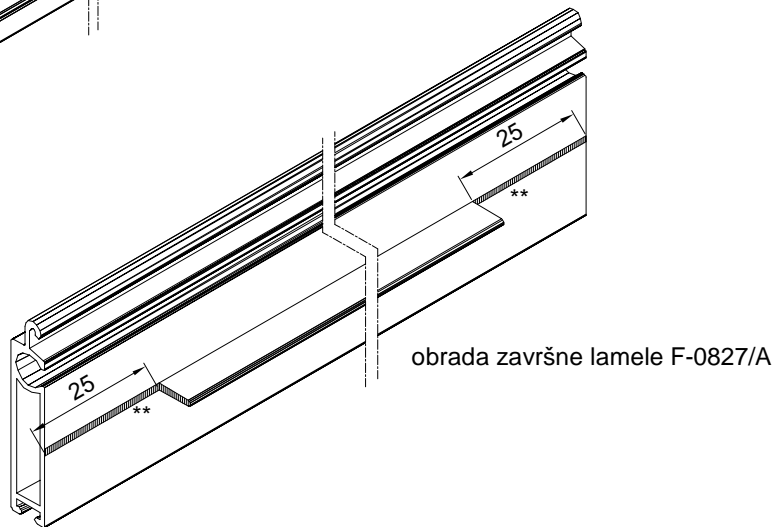
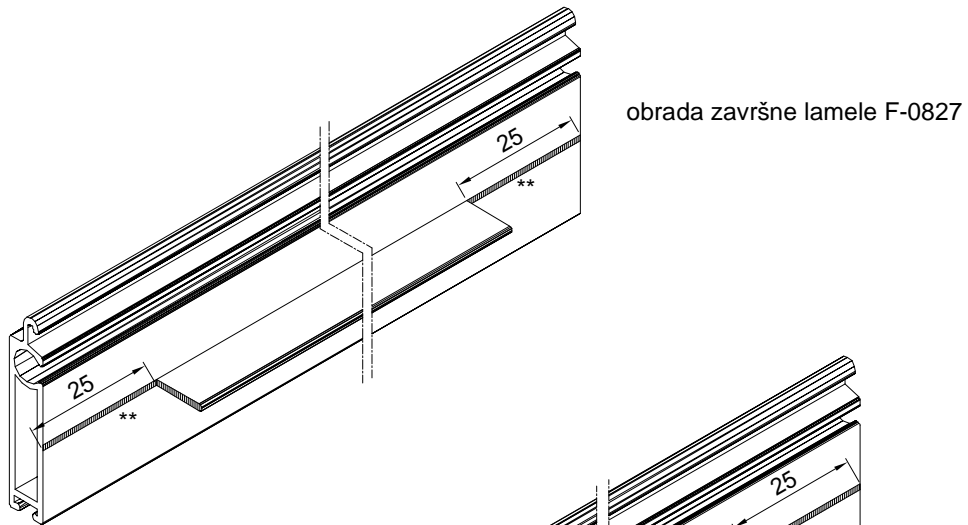

obrada završne lamele F-0827

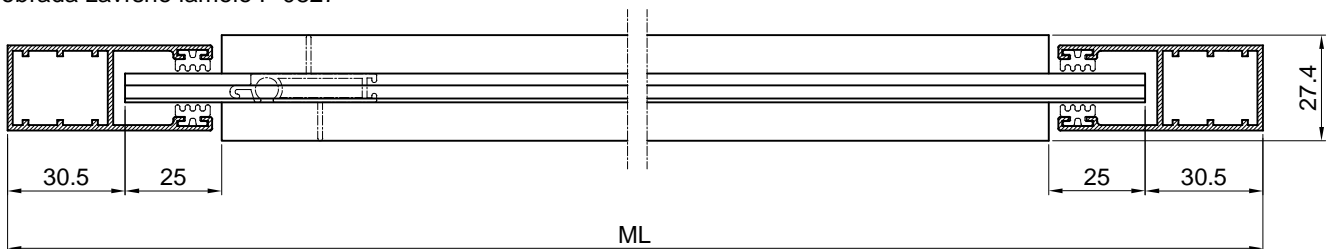

obrada završne lamele F-0827/A

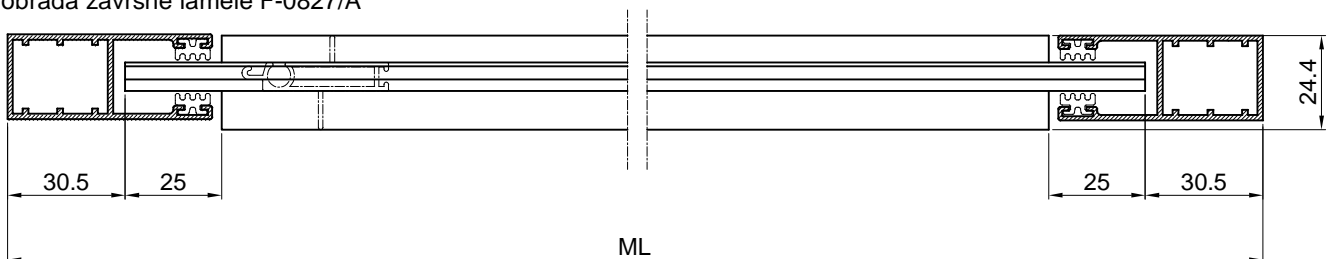

a) mogućnost obrade lamele na zadanu mjeru i plastificiranje

b) mogućnost isporuke plastificirane šipke (L=6500 mm), tako da kupac izvrši obradu i dodatno oboji (kistom) obrađenu površinu \*\*.

- pričvršćivanje čepova 375.046 za lamelu

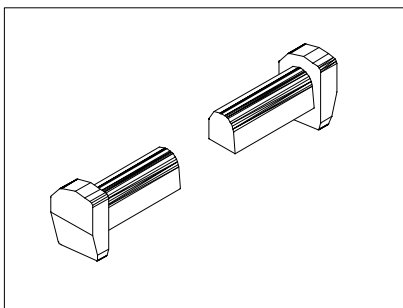
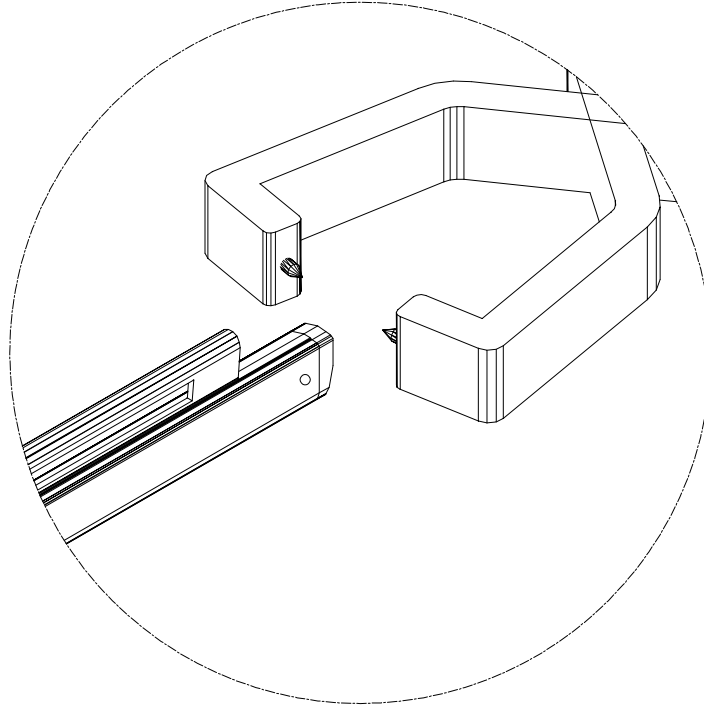

bočni čep lamele F-1087  
375.046

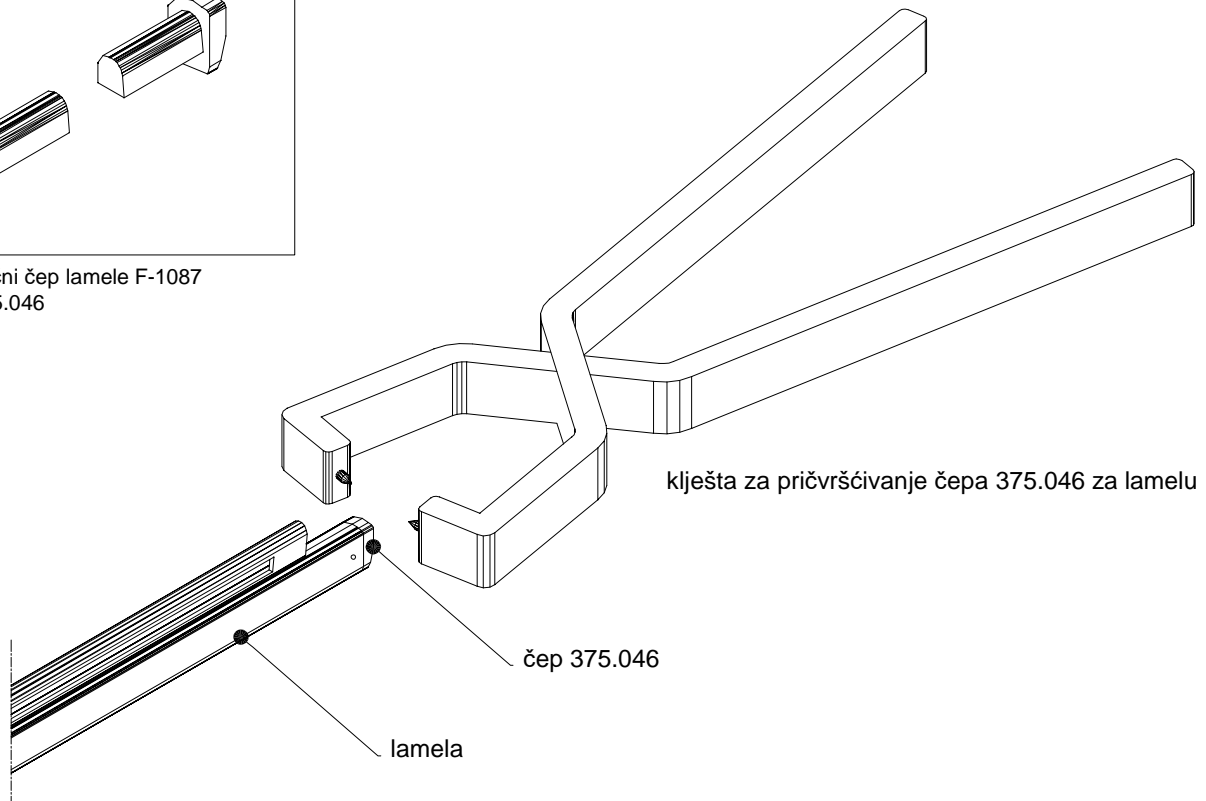

klješta za pričvršćivanje čepa 375.046 za lamelu

čep 375.046

lamela

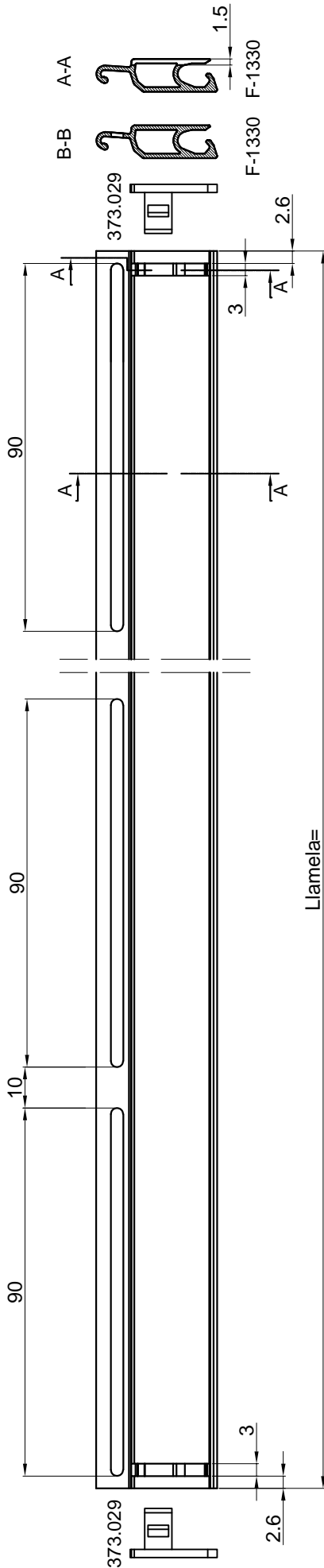

A-A

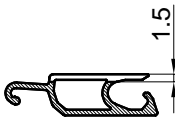

F-1330

B-B



F-1330

373.029

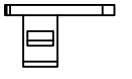

2.6

Llamela=

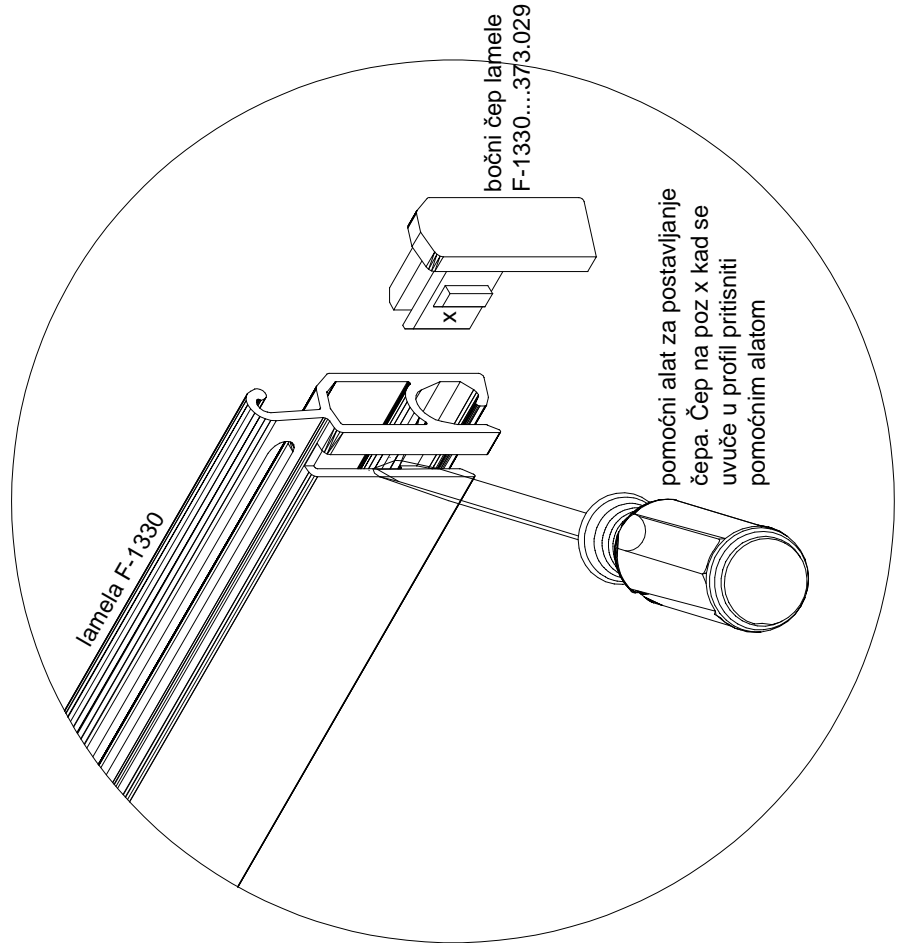

bočni čep lamele  
F-1330....373.029

pomoćni alat za postavljanje  
čepa. Čep na poz x kad se  
uvuče u profil pritisnuti  
pomoćnim alatom

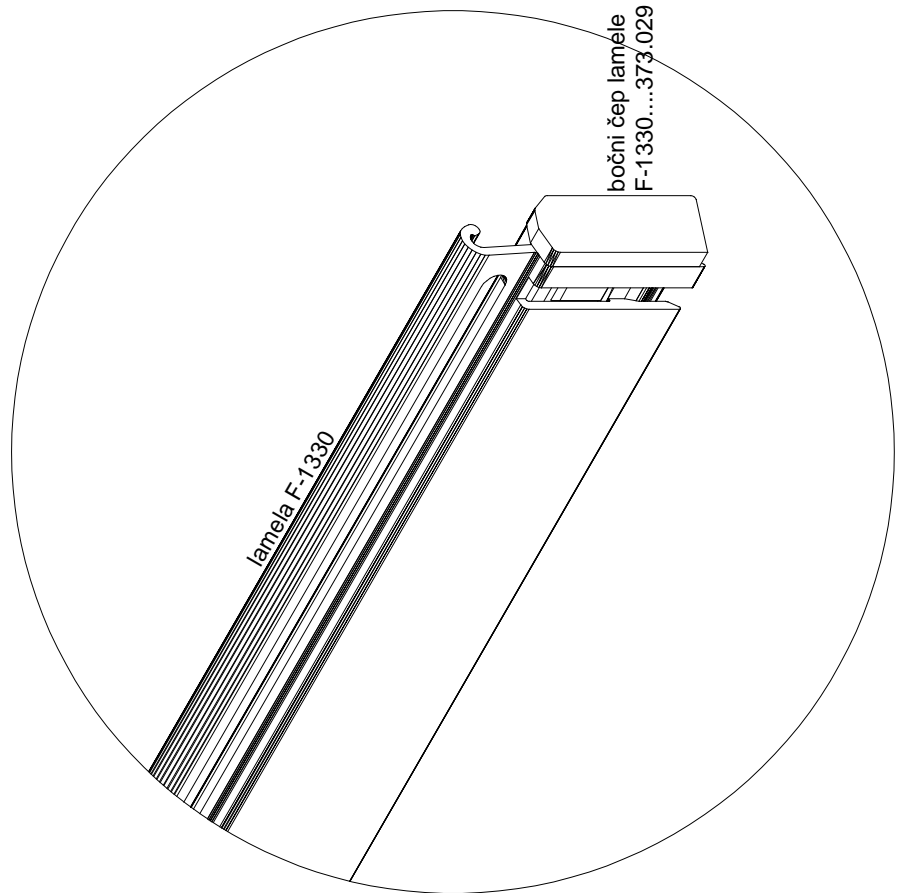

bočni čep lamele  
F-1330....373.029

## Pilanje lamela SP-10 i SP-20 sa utorom 10x3.5 mm

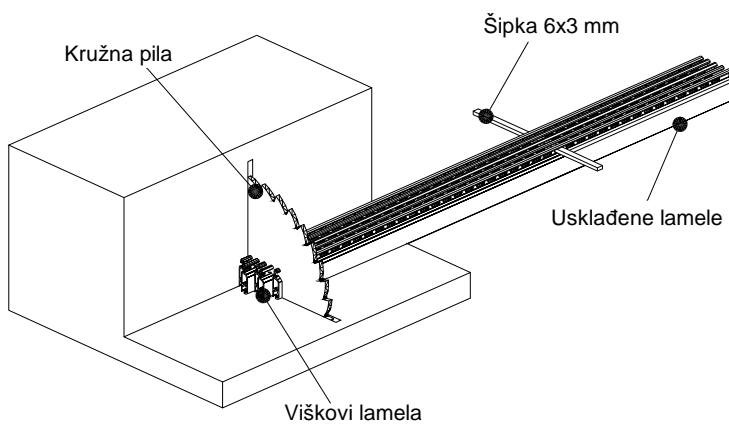
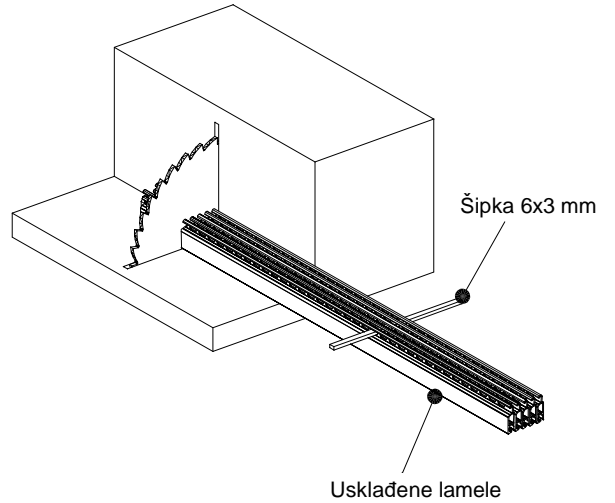
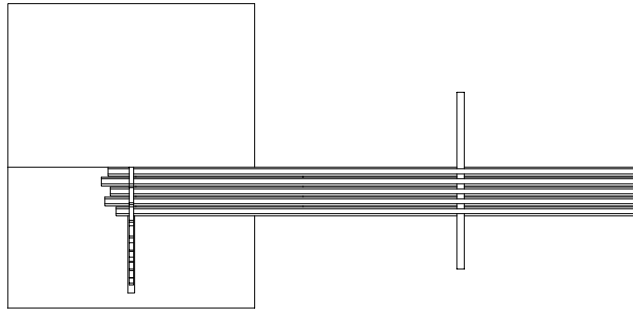

Plast sa pravilno raspoređenim utorima

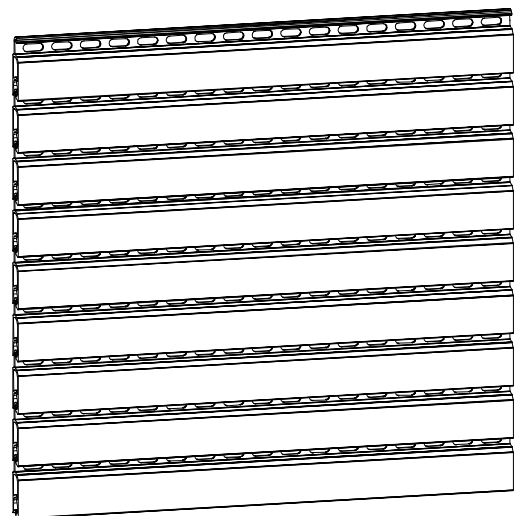

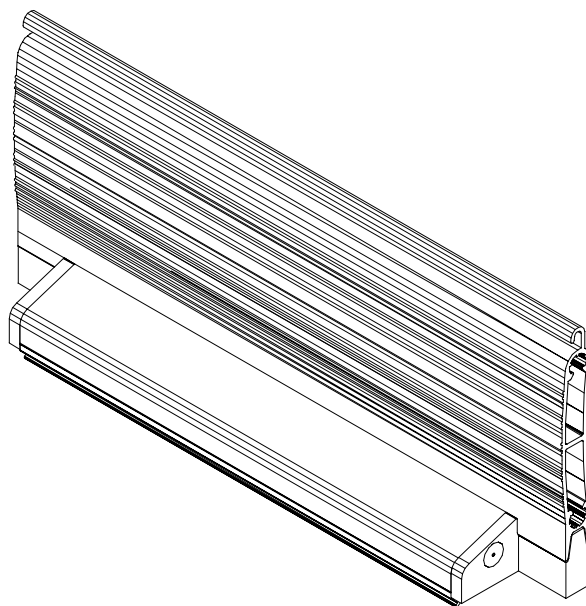
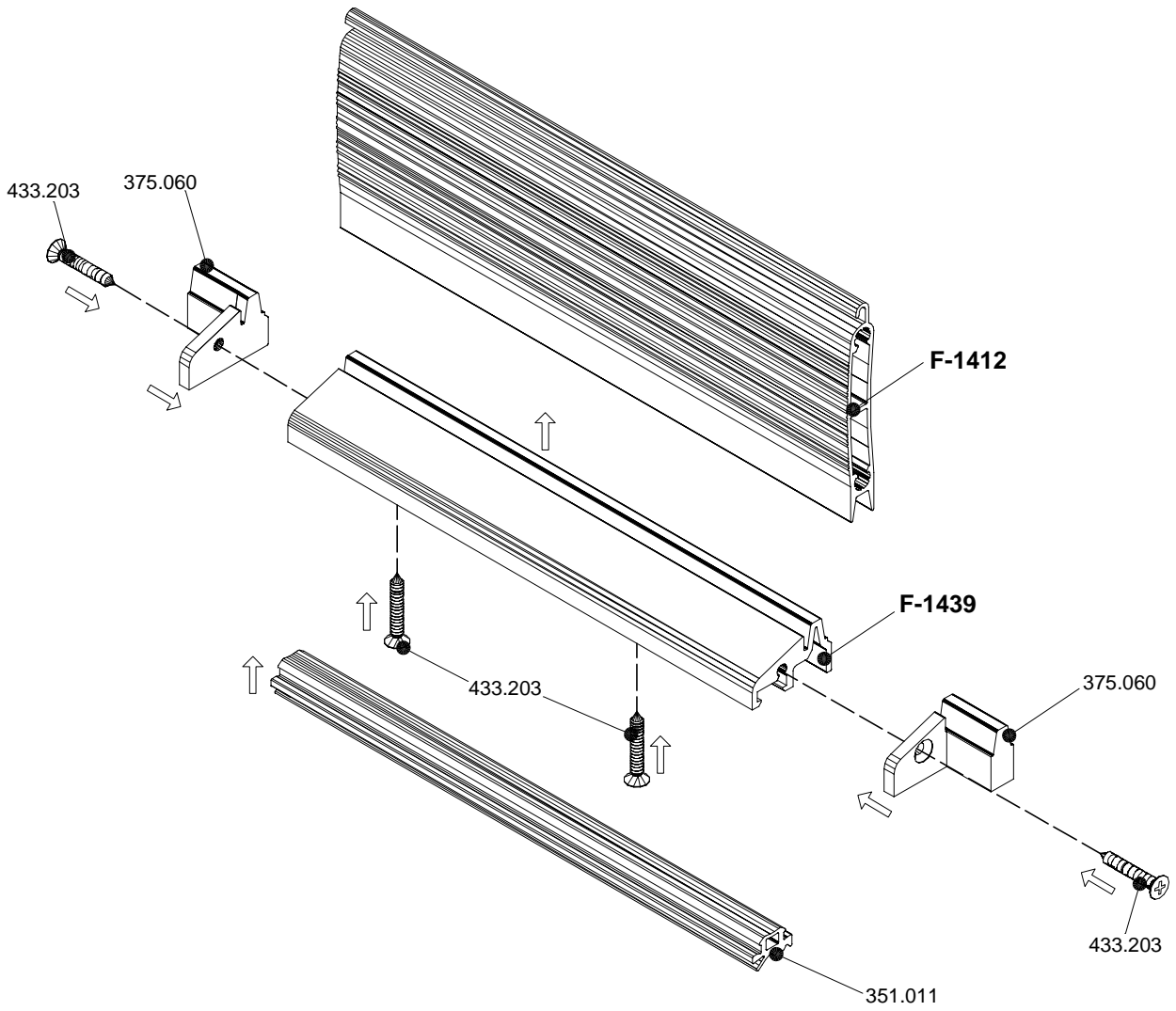

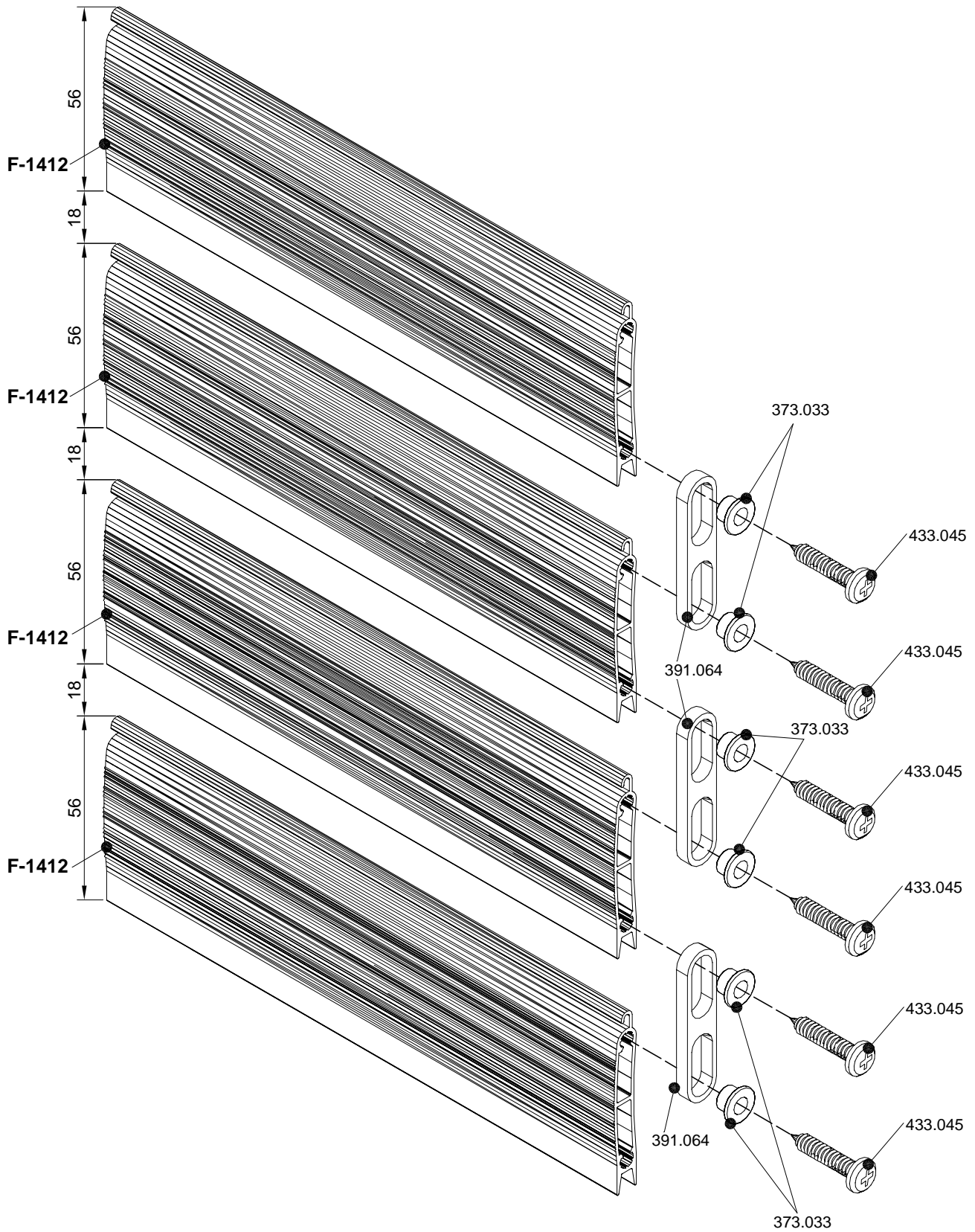

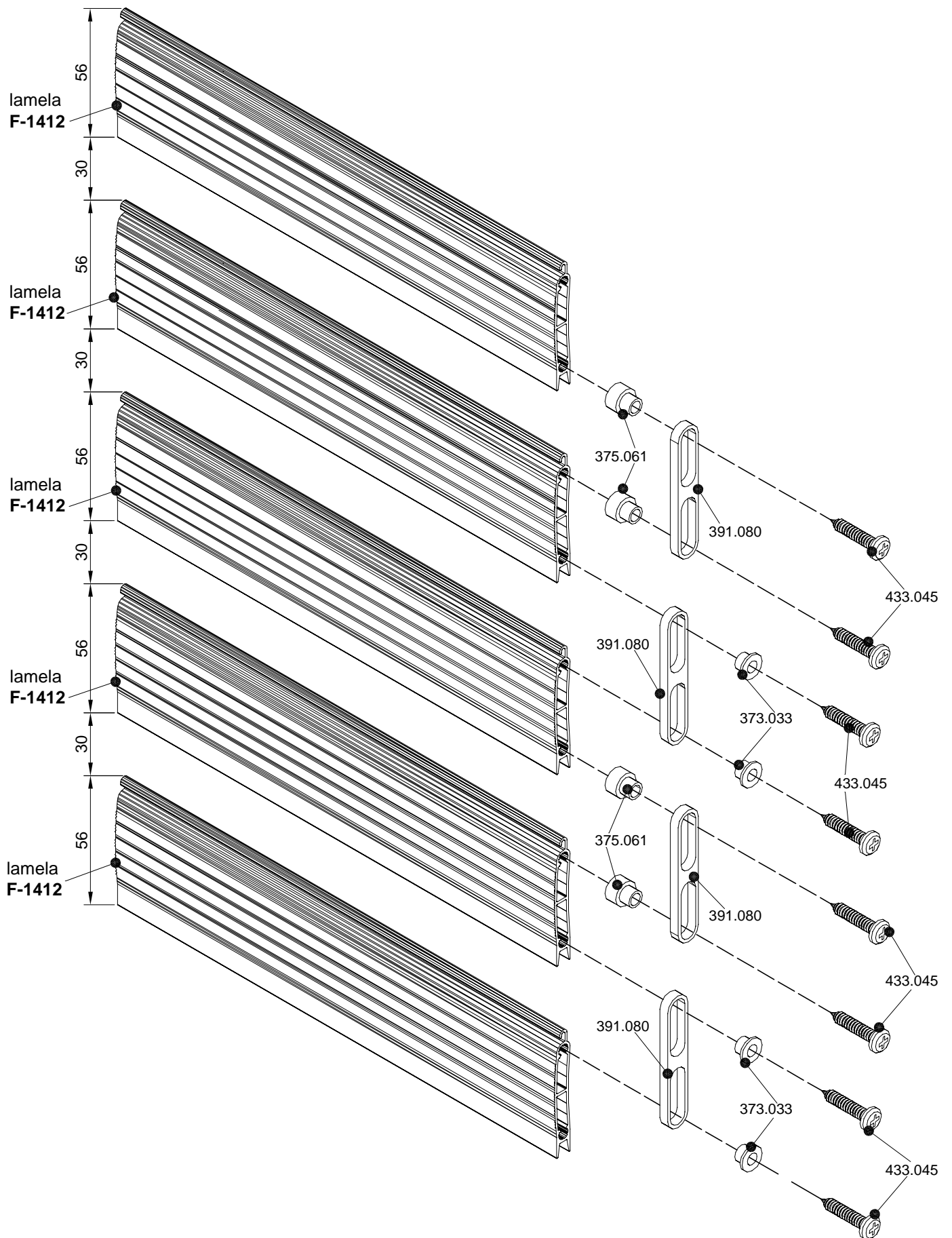

SP-50 dužina lamela  
- razmak 18 mm -

SP-50 dužina lamela  
- razmak 30 mm -

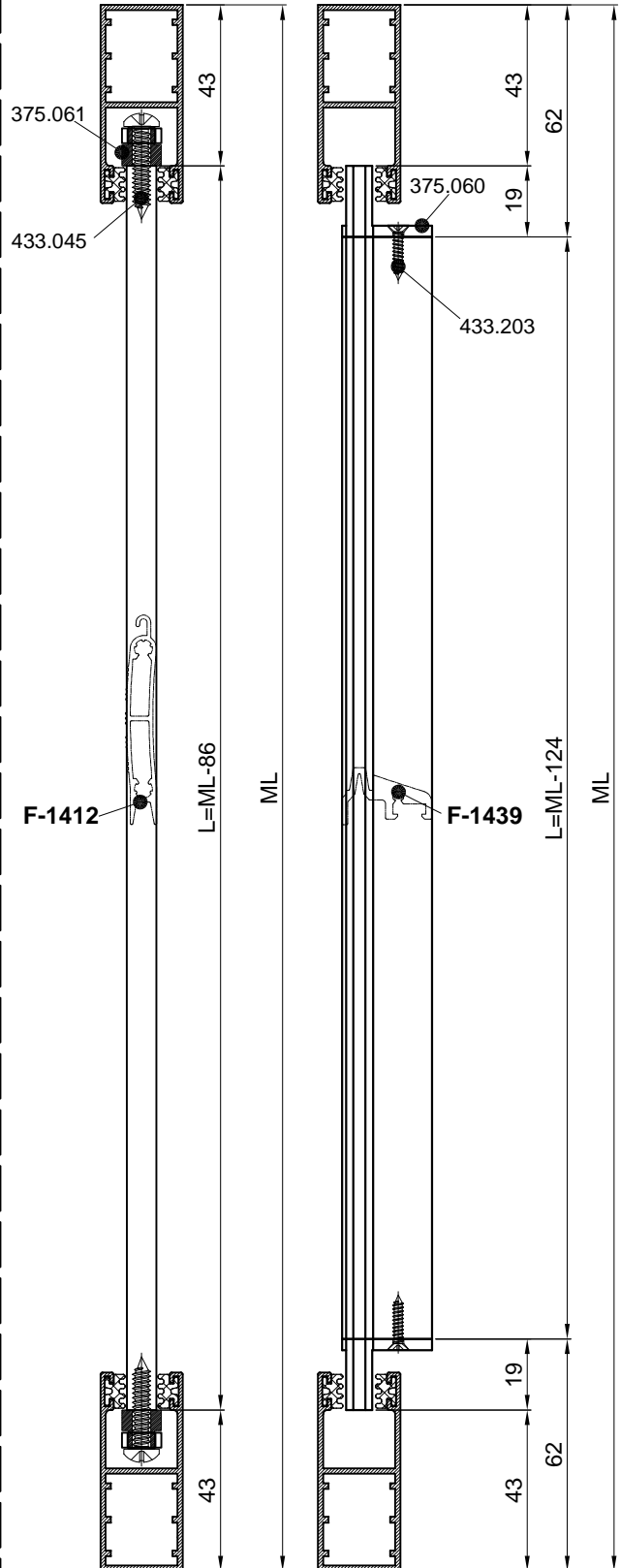
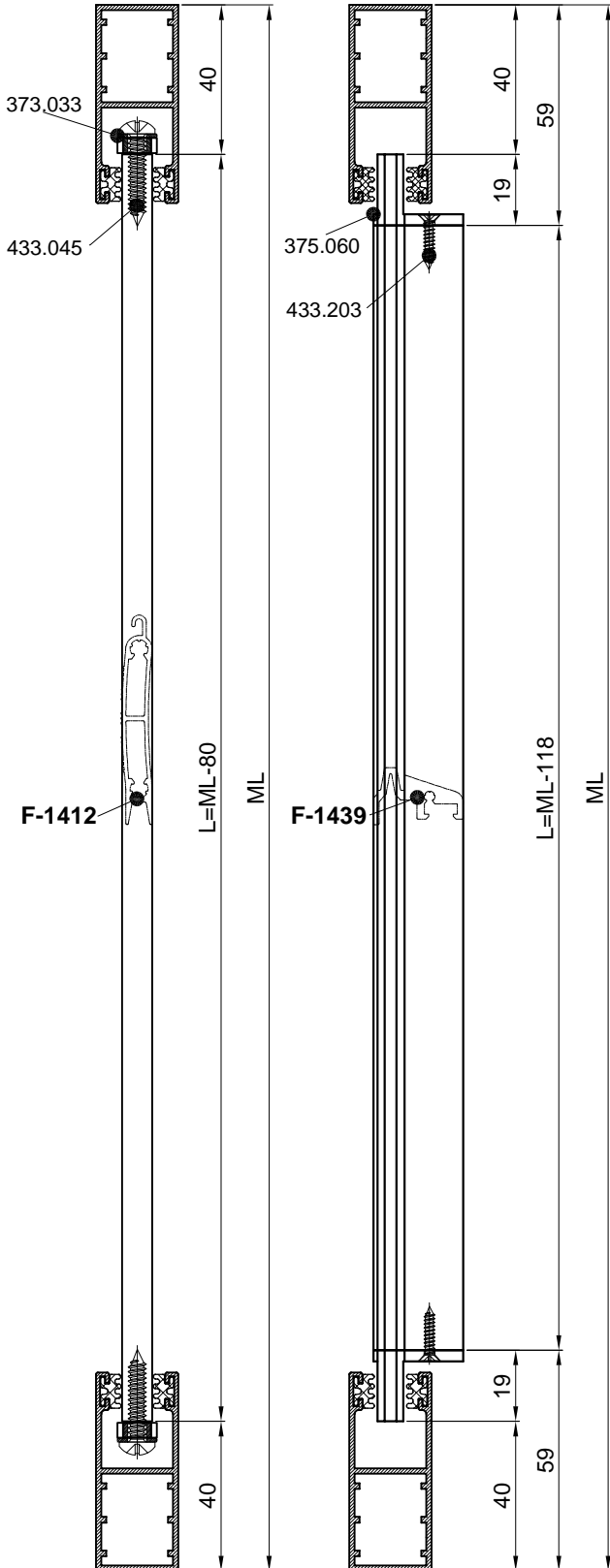

### TERMOKUTIJA 170

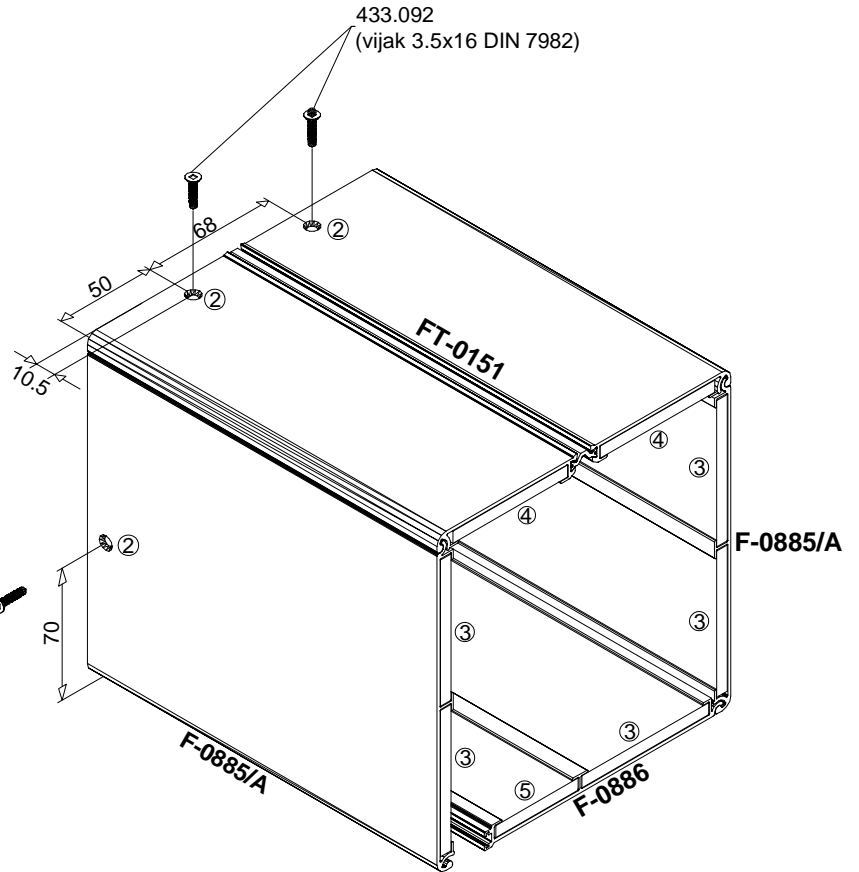
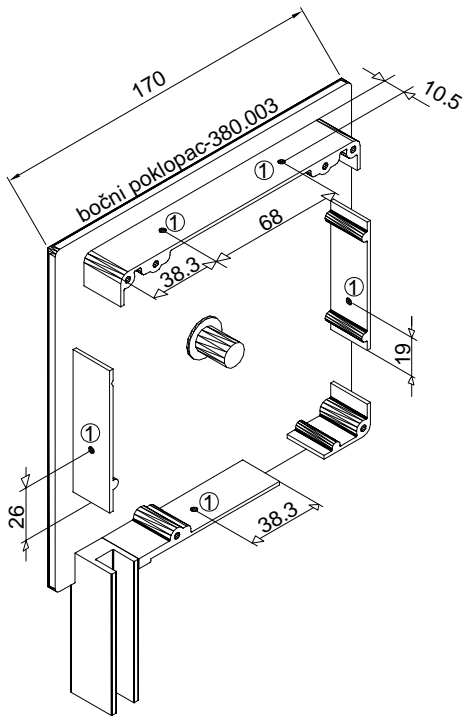

433.092  
(vijak 3.5x16 DIN 7982)

- 1 ..... otvor Ø10
- 2 ..... upustit otvor 3.5/90 za vijak
- 3 ..... 6x72 mm, termoizolacijska traka (6 mm) niske toplinske vodljivosti-stiropor
- 4 ..... 6x65 mm, termoizolacijska traka (6 mm) niske toplinske vodljivosti-stiropor
- 5 ..... 6x47 mm, termoizolacijska traka (6 mm) niske toplinske vodljivosti-stiropor

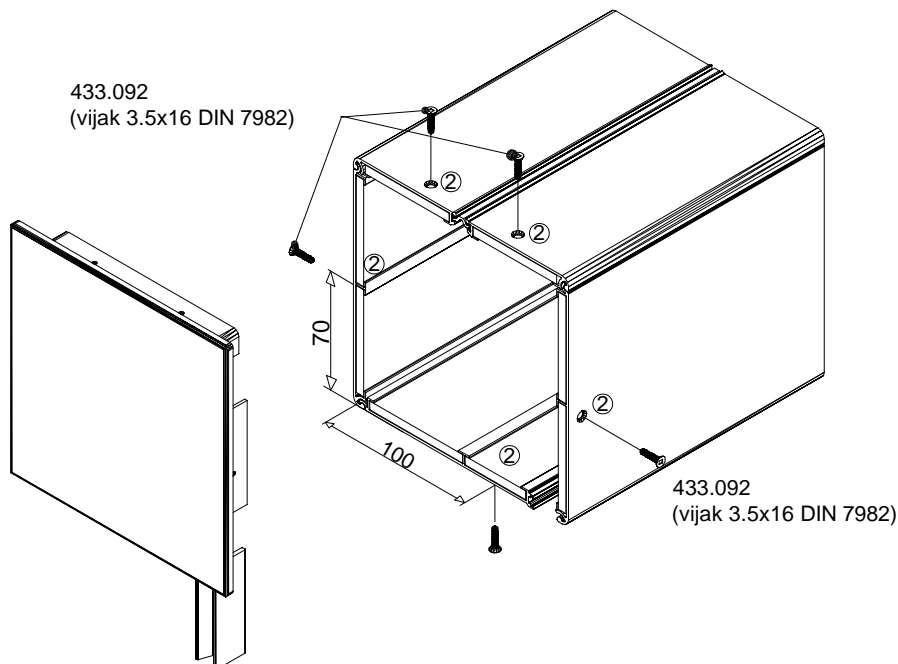

433.092  
(vijak 3.5x16 DIN 7982)

433.092  
(vijak 3.5x16 DIN 7982)

## TERMOKUTIJA 200

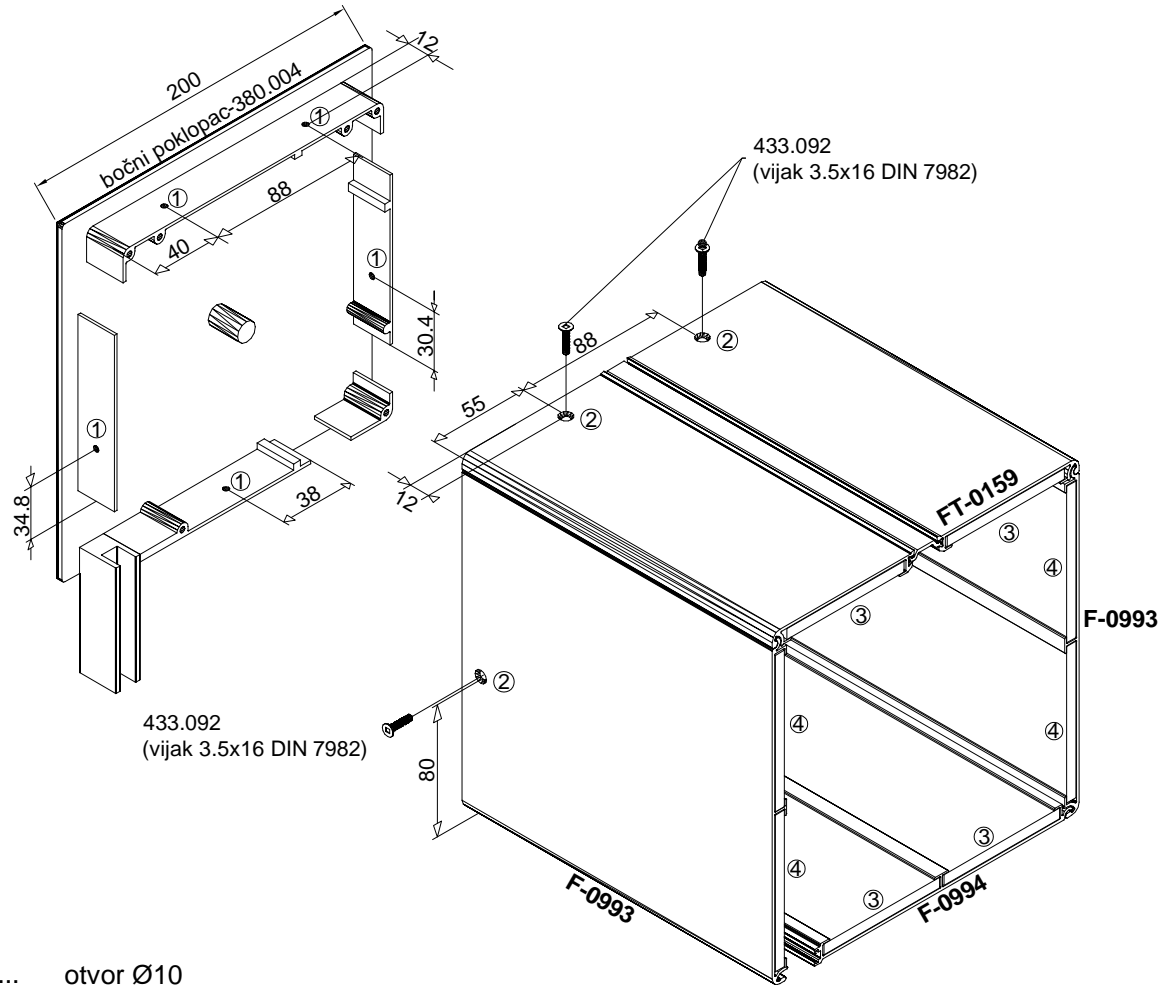

- 1 ..... otvor Ø10
- 2 ..... upustit otvor 3.5/90 za vijak
- 3 ..... 6x75 mm, termoizolacijska traka (6 mm) niske toplinske vodljivosti-stiropor
- 4 ..... 6x87 mm, termoizolacijska traka (6 mm) niske toplinske vodljivosti-stiropor

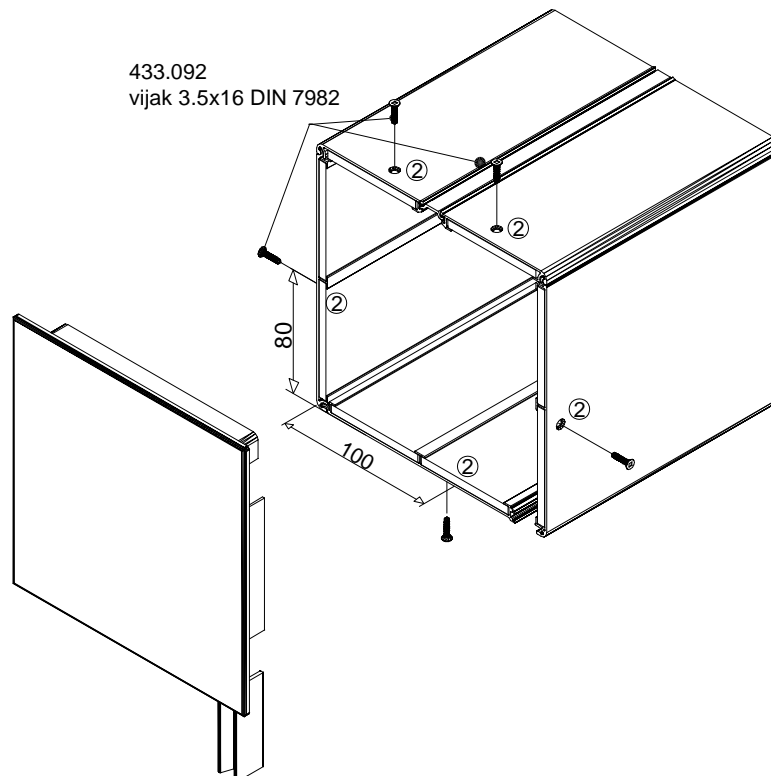

## Kutija 250

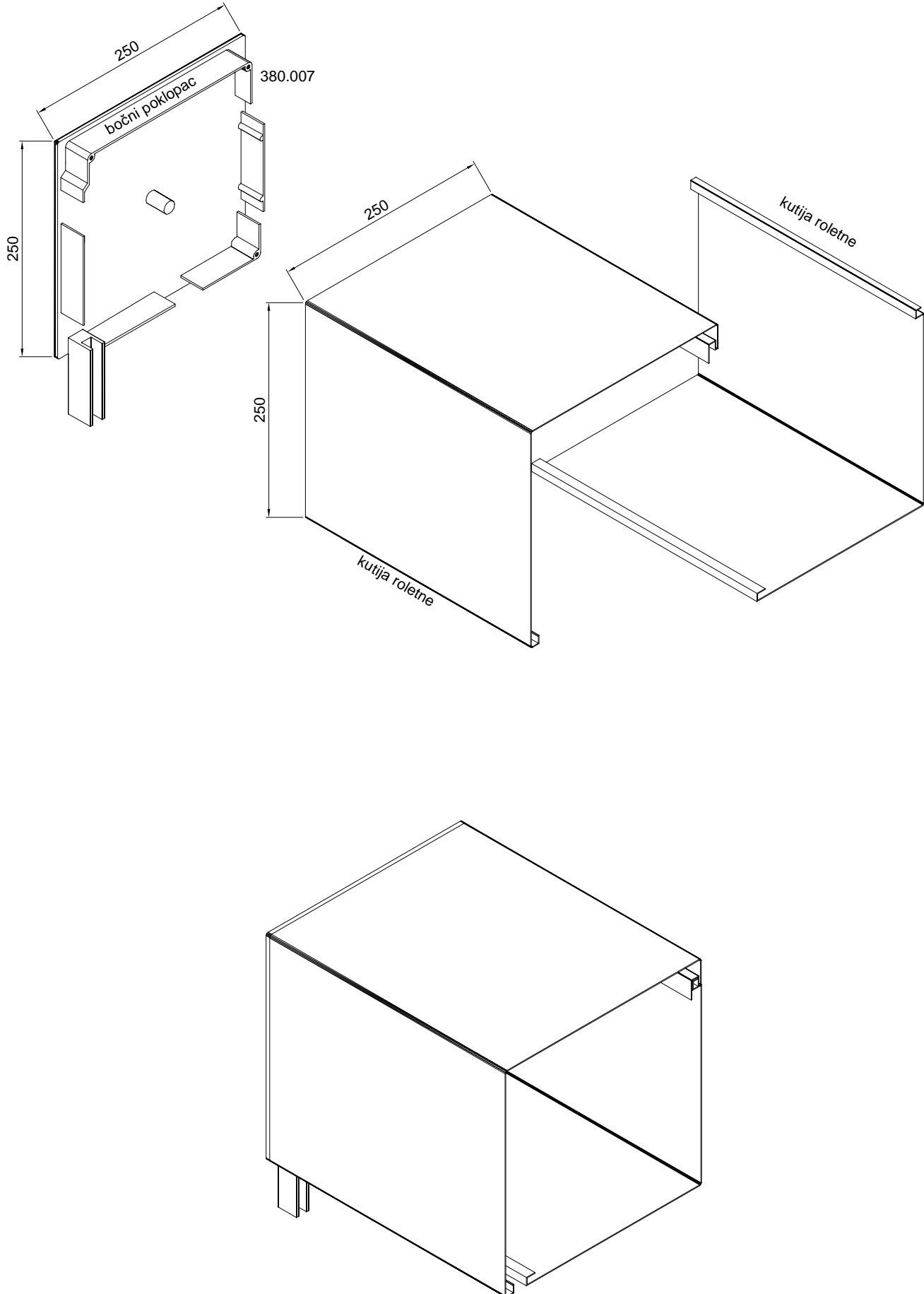

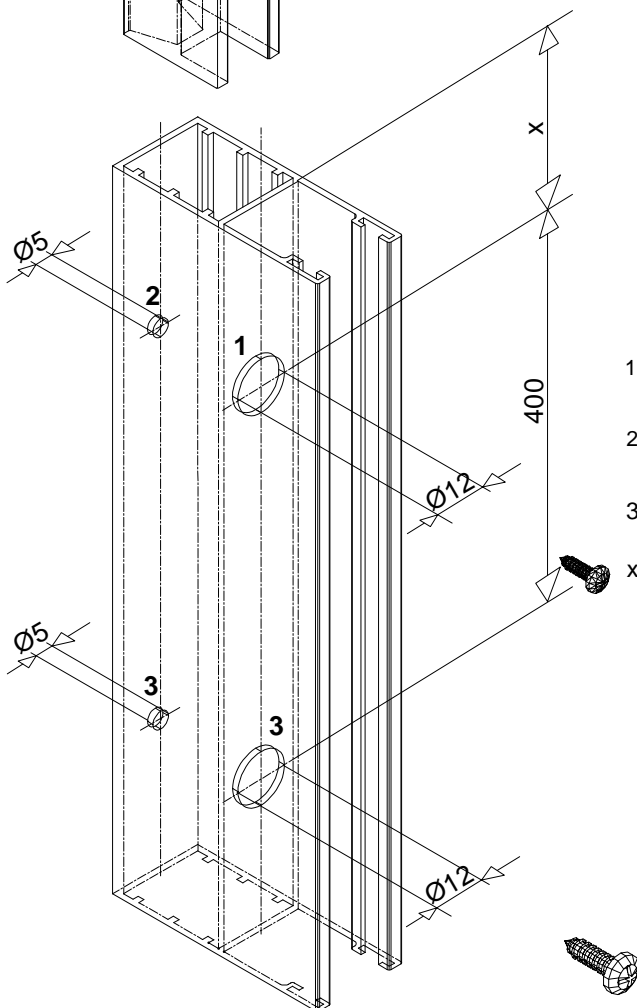
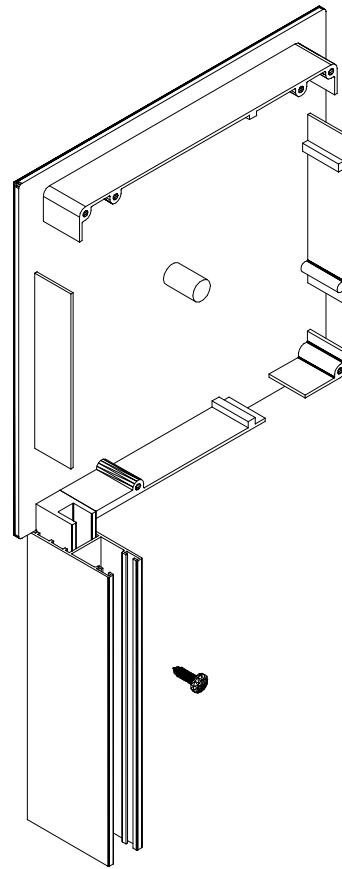
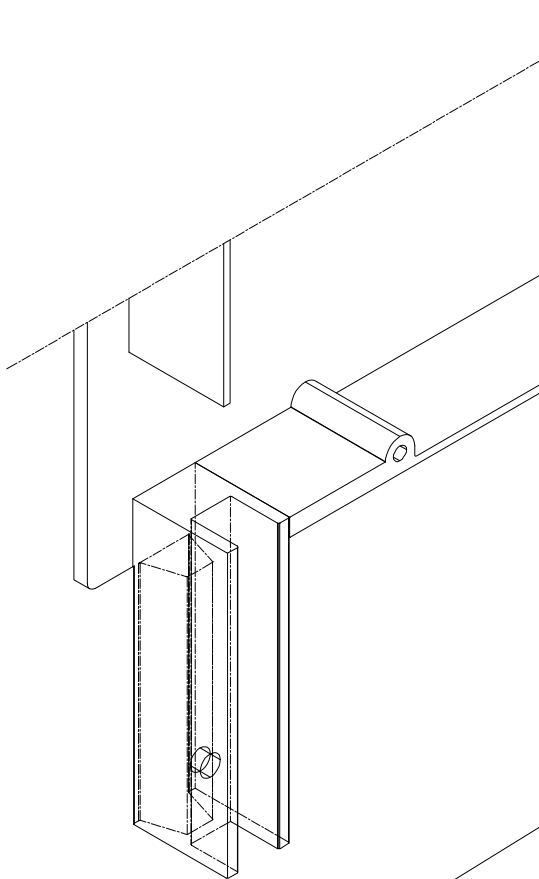

- 1 ..... otvor Ø12 (za pričvršćivanje bočnog poklopca za vodilicu)
- 2 ..... otvor Ø5 (za pričvršćivanje bočnog poklopca za vodilicu)
- 3 ..... otvor Ø12 i Ø5 (za fixiranje vodilice-svakih 400 mm)
- x ..... ovisno o tipu kutije ( vidi tablicu)

Tip kutije	Dimenzija x
Termokutija 170	51
Kutija 165	53
Termokutija 20	41
Kutija 20	49
Kutija 250	61

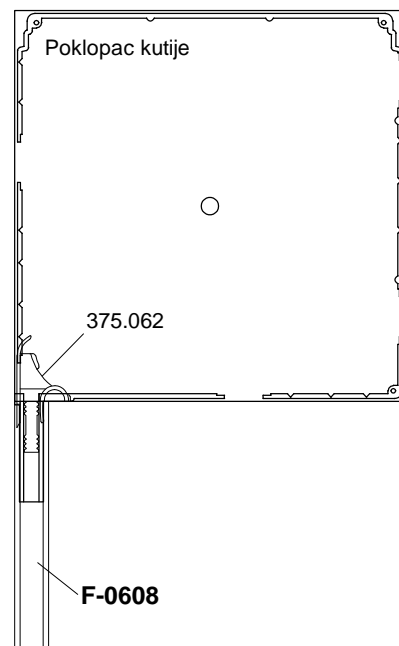
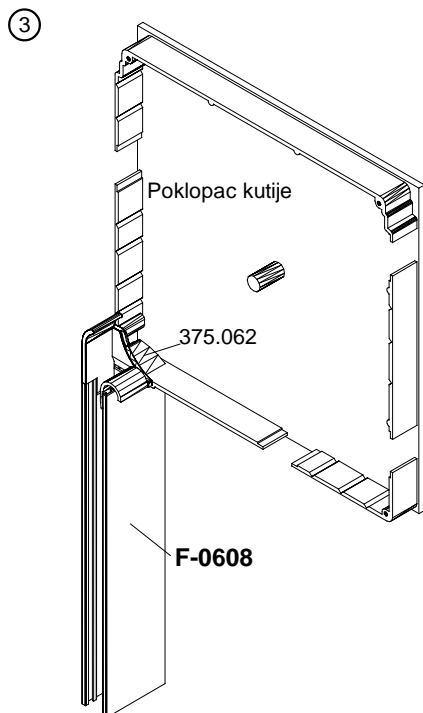
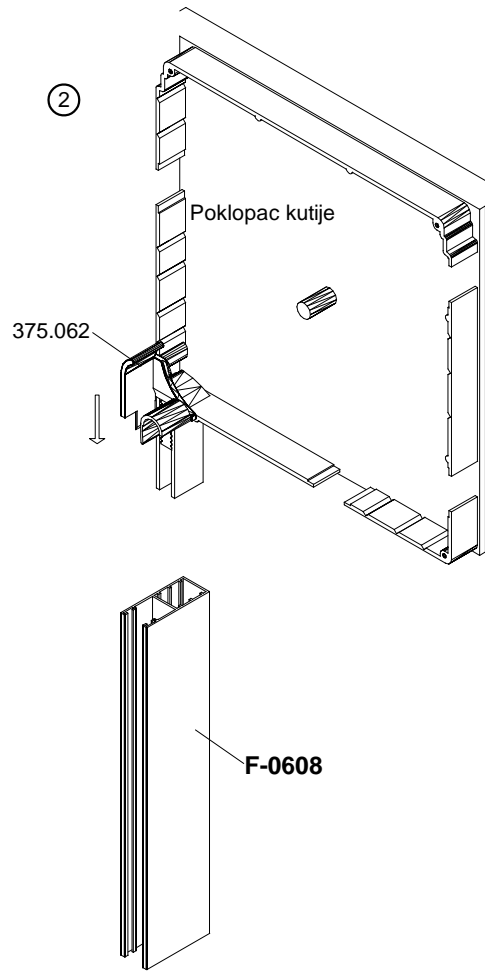
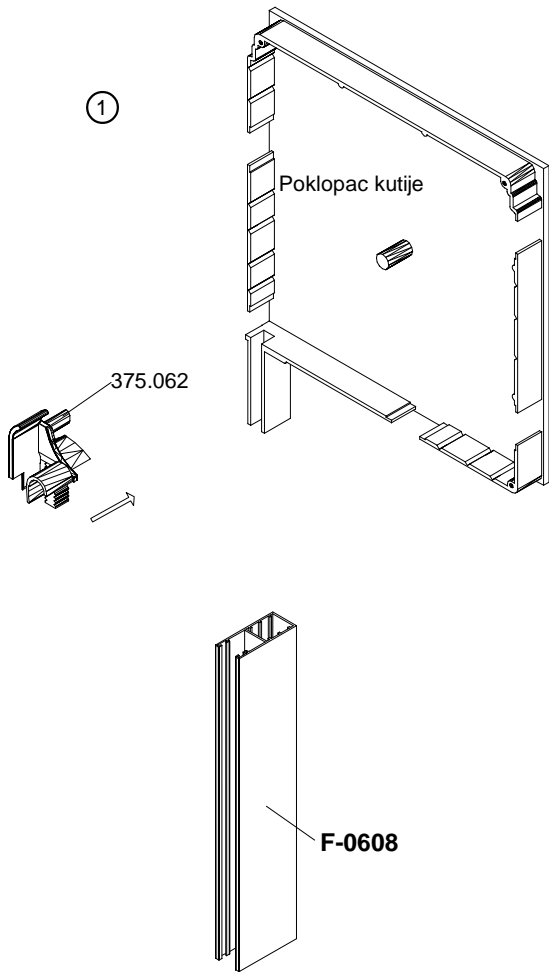





# FEAL

## SP SJENILA / *ROLLER SHUTTER*

Svibanj 2021. / *May 2021*

FEAL d.o.o.  
Trnska cesta 146  
88220 Široki Brijeg  
Bosna i Hercegovina  
Tel. +387 39 704-269; 705-807; 705-636  
Fax. +387 39 704-358  
info@feal.ba  
www.feal.ba