

SOFA SYSTEM

CAMELOT

DESIGN ANTONIO CITTERIO

FLEXFORM

SOFA SYSTEM

CAMELOT

DESIGN ANTONIO CITTERIO

FLEXFORM

“EVEN VISUALLY, THIS SOFA IMMEDIATELY CONVEYS A SENSATION OF COMFORT.
THE CUSHIONS ARE SUPPORTED BY AN EXTERNAL TUBULAR STRUCTURE
AND THAT IS WHAT LENDS THE PRODUCT ITS CHARACTER.”

Antonio Citterio

Progettato da Antonio Citterio con in mente uno stile di vita contemporaneo, sobrio e informale, il sistema di sedute Camelot comunica immediatamente un senso di comfort, comodità e benessere. A determinarne il carattere, l'originale combinazione tra il rigore del progetto e l'immagine soffice e accogliente: la struttura costituita da staffe in metallo e barra cilindrica sostiene i cuscini morbidi e generosi, che disponendosi a ventaglio suggeriscono un invito al relax. La varietà dei componenti, in termini sia di modularità che di materiali disponibili, consente un'elevata flessibilità progettuale e amplia le possibilità di personalizzazione. La scelta riguarda i rivestimenti, in tessuto o pelle, le finiture metalliche per le staffe e anche il supporto tubolare, che può essere realizzato in numerose essenze pregiate di legno o rivestito in cuoio. I dettagli di confezione, espressione dell'attitudine alla sartorialità propria di Flexform, costituiscono ricercati elementi di richiamo visivo. Come il profilo che rifinisce i cuscini, proposto in colore contrastante o ton-sur-ton, che diventa segno grafico sulla superficie del divano.

Designed by Antonio Citterio with a contemporary, unpretentious, casual lifestyle in mind, the Camelot seating system immediately expresses a sense of comfort, ease and well-being. The unique juxtaposition of the design's formal austerity and sofa's cozy, welcoming image defines its personality. The external structure consists of metal braces and cylindrical bars that support the soft, generously sized cushions, which fan out in a silent invitation to sit and relax. The array of components, in terms of modularity and choice of materials, allows for considerable flexibility in design options and expands the possibilities for customization. Choices revolve around upholstery selection - in fabric or leather - and metal finishes on the braces and cylindrical supports, which can be crafted in numerous types of premium wood or clad in cowhide. Craftsmanship details, an expression of Flexform's aptitude for custom tailoring, are sophisticated elements of great visual appeal. Like the piping that outlines the cushions, available in contrasting color or tone-on-tone, which conveys a distinctive graphic message of subtle elegance.

THE SOFA'S PERSONALITY AND VERSATILITY ALLOW IT TO INTERACT SPONTANEOUSLY WITH THE OTHER FURNISHINGS IN THE COLLECTION, INFUSING THE INTERIOR DECOR WITH A NEW IDEA OF "MODERN WARMTH".

ESPRESSIONE DELLA FLESSIBILITÀ COMPOSITIVA DI CAMELOT, LA CONFIGURAZIONE ANGOLARE METTE IN EQUILIBRIO COMFORT E FUNZIONALITÀ, CREANDO UN INSIEME DI SOFFICE ARMONIA VISIVA.

AN EXPRESSION OF CAMELOT'S COMPOSITIONAL FLEXIBILITY, THE CORNER CONFIGURATION BALANCES COMFORT AND FUNCTIONALITY, CREATING AN OVERALL SENSE OF SOFT VISUAL HARMONY.







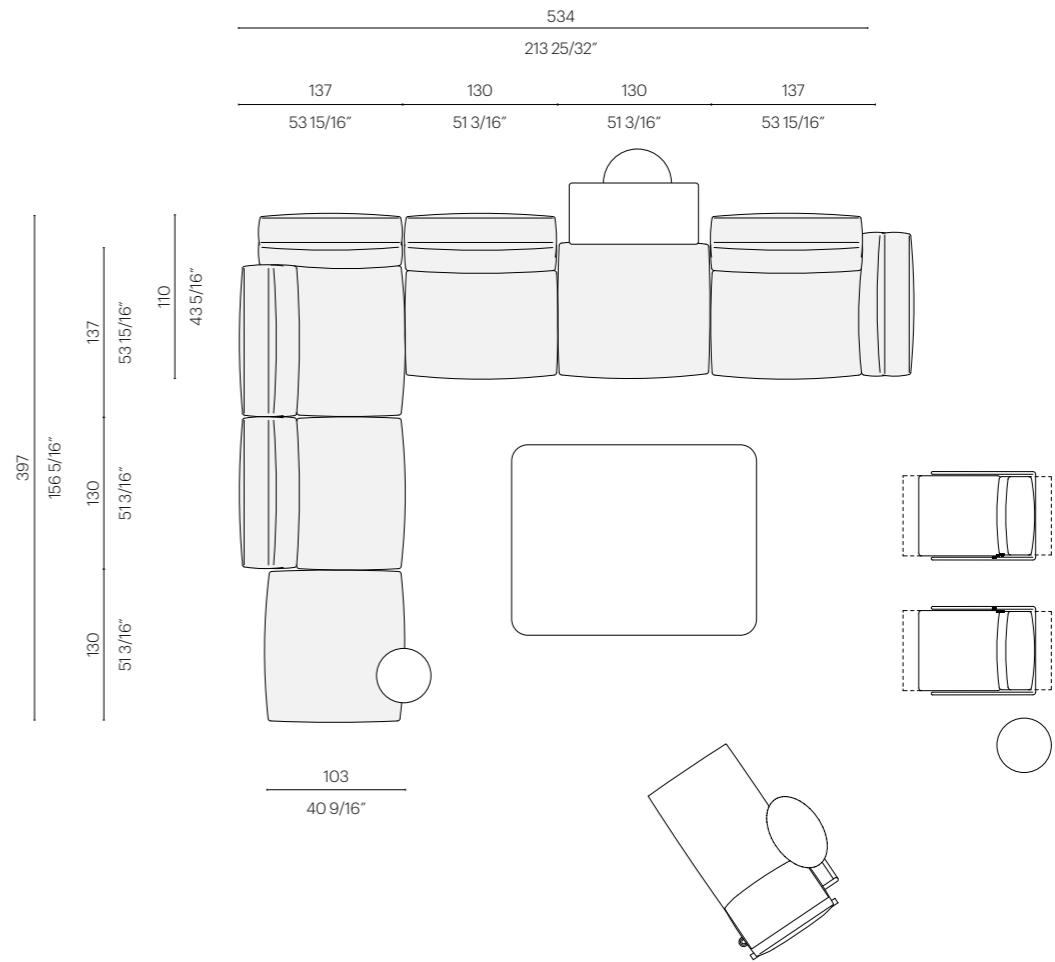

Camelot, divano componibile pianale in legno rivestito in cuoio color tabacco 5015, staffe in metallo titanium opaco 710, barra in legno rivestita in cuoio color tabacco 5015, cuscini di seduta, schienale e optional rivestiti in tessuto Medina 90, profilo in gros grain 094. **Ginger, chaise longue** struttura in metallo cromato, barra di schienale e tavolino pivotante in legno rivestiti in pelle Deluxe 629, cuscini di seduta e schienale rivestiti in tessuto Medina 90, profilo in gros grain 094. **A.B.C., poltrone** struttura in metallo cromato, schienale e seduta rivestiti in pelle Deluxe 629. **Arnold, tavolino** struttura in rovere effetto grezzo, piedi in metallo titanium opaco 710, piano in vetro retroverniciato color Seta 2010. **Earl, contenitore** struttura impiallacciata in rovere effetto grezzo, piedi in metallo titanium opaco 710. **Fly, tavolino** Struttura in metallo titanium opaco 710, piano in rovere effetto grezzo. **Cestone, tavolino di servizio** struttura in metallo titanium opaco 710, piano in rovere effetto grezzo. **Feel good, pouf** seduta e cuscino in pelle Deluxe 629, piedi in metallo titanium opaco 710. **Mori, tappeto** lana e cotone, colore Milk, Juma design.

Camelot, sectional sofa wood platform clad in cowhide color tabacco 5015, metal braces in matt titanium 710, wood bar clad in cowhide tabacco color 5015, seat, backrest and optional cushions upholstered in Medina 90 fabric, grosgrain 094 piping. **Ginger, chaise longue** metal structure with chrome finish, backrest bar and rotating side table in wood clad in Deluxe 629 leather, seat and backrest cushions upholstered in Medina 90 fabric, grosgrain 094 piping. **A.B.C., armchairs** metal structure with chrome finish, backrest and seat upholstered in Deluxe 629 leather. **Arnold, coffee table** structure in oak with raw-wood effect, metal feet in matt titanium 710, top in glass back-painted in Silk 2010. **Earl, storage unit** structure veneered in oak with raw-wood effect, metal feet in matt titanium 710. **Fly, coffee table** metal structure in matt titanium 710, top in oak with raw-wood effect. **Cestone, side table** metal structure in matt titanium 710, top in oak with raw-wood effect. **Feel good, ottoman** seat and cushion in Deluxe 629 leather, metal feet in matt titanium 710. **Mori, rug** wool and cotton, Milk color, Juma design.

THE STAND-ALONE VERSION
WITH ARMRESTS IS THE CONSUMMATE
EXPRESSION OF CHARACTER
AND ARCHETYPAL ENERGY.

PROTAGONISTA ASSOLUTO DELLA SCENA, CAMELOT INTRODUCE UN NUOVO LINGUAGGIO
NELL'ARREDO DEGLI AMBIENTI DEPUTATI ALL'OSPITALITÀ, IN GRADO DI COMBINARE
ELEGANTEMENTE STILI E FUNZIONI, FORMALITÀ E INFORMALITÀ.

ABSOLUTE STAR OF THE SCENE, CAMELOT USHERS IN A NEW LANGUAGE
IN THE FURNISHING OF HOSPITALITY SPACES, ABLE TO ELEGANTLY COMBINE STYLES
AND FUNCTIONS, FORMALITY AND INFORMALITY.





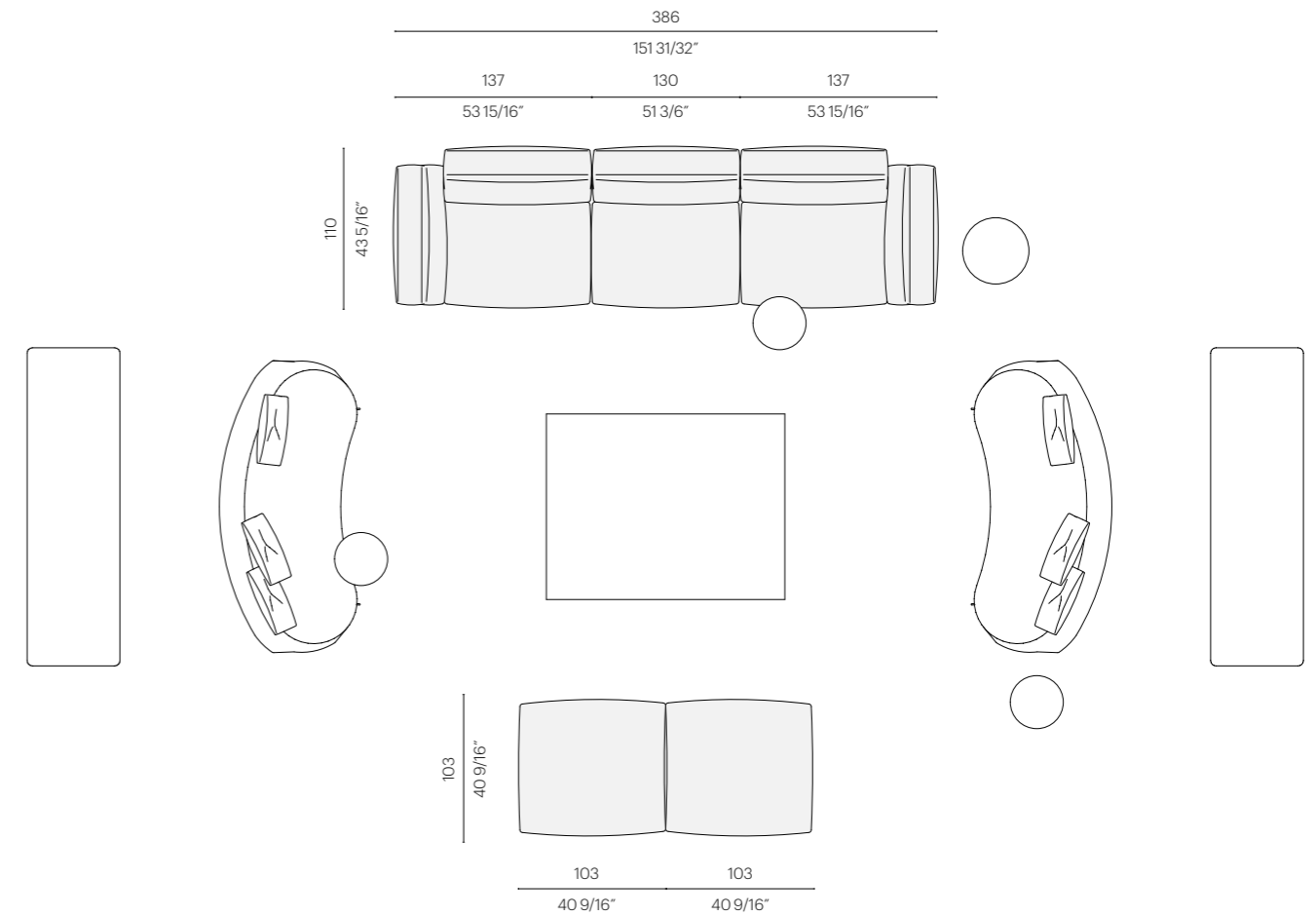

Camelot, divano componibile e pouf pianale in legno rivestito in cuoio color rosso bulgaro 5008, staffe in metallo titanium opaco 710, barra in legno rivestita in cuoio color rosso bulgaro 5008, cuscini di seduta, schienale e optional rivestiti in pelle Prime 74, profilo in gros grain 087. **Guscio, divani lineari** piedi in metallo titanium opaco 710, schienale e cuscini rivestiti in tessuto Medina 90. **Adler, console** struttura in noce canaletto effetto grezzo, piedi in metallo titanium opaco 710, piano in noce canaletto effetto grezzo. **Este, tavolino** struttura in metallo titanium opaco 710, piano in marmo grigio Stardust opaco. **Fly, tavolini** struttura in metallo titanium opaco 710, piano in noce canaletto effetto grezzo. **Guscio, poltrone** schienale e cuscino rivestiti in tessuto Medina 90, piedi in metallo titanium opaco 710. **Inca, tappeto** lana e cotone, colore Pearl, Juma design.

Camelot, sectional sofa and ottoman wood platform clad in cowhide color Russian red 5008, metal braces in matt titanium 710, wood bar clad in cowhide color Russian red 5008, seat, backrest and optional cushions upholstered in Prime 74 leather, grosgrain 087 piping. **Guscio, stand-alone sofas** metal feet in matt titanium 710, backrest and cushions upholstered in Medina 90 fabric. **Adler, console** structure in Canaletto walnut with raw-wood effect, metal feet in matt titanium 710, top in Canaletto walnut with raw-wood effect. **Este, coffee table** metal structure in matt titanium 710, top in matt grey Stardust marble. **Fly, coffee tables** metal structure in matt titanium 710, top in Canaletto walnut with raw-wood effect. **Guscio, armchairs** backrest and cushion upholstered in Medina 90 fabric, metal feet in matt titanium 710. **Inca, rug** wool and cotton, Pearl color, Juma design.

THE ESSENCE OF RELAXATION
IN A COMBINATION OF SUPER-SOFT
ELEMENTS OF DIFFERENT DEPTHS.

PERFETTO INTERPRETE DI UNA FILOSOFIA IMPRONTATA AL COMFORT,
CAMELOT CONSENTE DI CREARE RAFFINATE ISOLE DI BENESSERE NELLA ZONA LIVING,
IDEALI SIA PER IL RIPOSO CHE PER LA CONVIVIALITÀ.

PERFECT INTERPRETER OF A PHILOSOPHY FOCUSED ON COMFORT,
CAMELOT MAKES IT POSSIBLE TO CREATE SOPHISTICATED ISLANDS OF WELL-BEING
IN THE LIVING AREA, IDEAL FOR RELAXATION AND FOR ENTERTAINING.





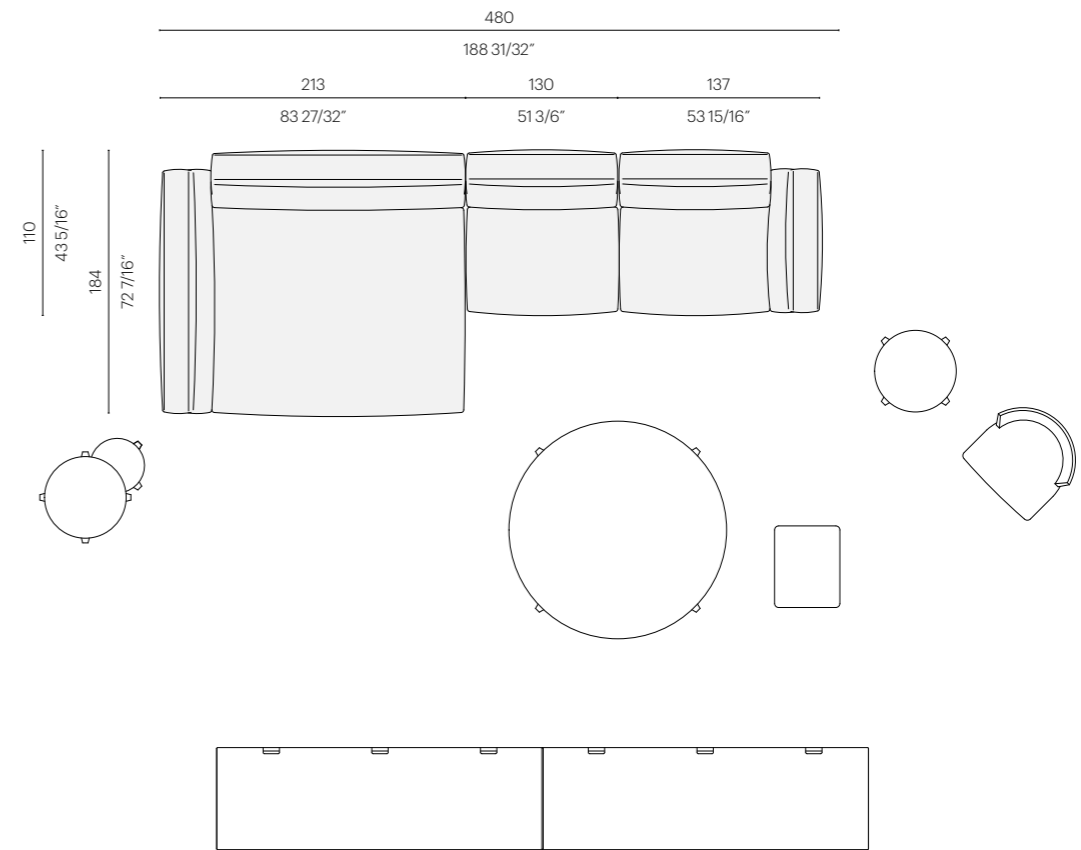

Camelot, divano componibile pianale in legno rivestito in cuoio color oliva 5006, staffe in metallo titanium opaco 710, barra in legno rivestita in cuoio color oliva 5006, cuscini di seduta e schienale rivestiti in tessuto Medina 93, cuscini optional rivestiti in tessuto Egypt 97, profilo in gros grain 162. **Thomas, poltrone** seduta rivestita in tessuto Elodie 1221, struttura in noce canaletto effetto grezzo. **Piuma, contenitore** struttura impiallacciata in noce canaletto effetto grezzo, piedi in metallo titanium opaco 710. **Bangkok, pouf** seduta rivestita in cuoio intrecciato color oliva 5006, piedi in metallo titanium opaco 710, Design Center design. **Tris, tavolini** struttura in noce canaletto effetto grezzo, piano in marmo Calacatta oro opaco, Design Center design. **Inca, tappeto** lana e cotone, colore Sand, Juma design.

Camelot, sectional sofa wood platform clad in cowhide color olive 5006, metal braces in matt titanium 710, wood bar clad in cowhide color olive 5006, seat and backrest cushions upholstered in Medina 93 fabric, optional cushions upholstered in Egypt 97 fabric, grosgrain 162 piping. **Thomas, armchairs** seat upholstered in Elodie 1221 fabric, structure in Canaletto walnut with raw-wood effect. **Piuma, storage unit** structure veneered in Canaletto walnut with raw-wood effect, metal feet in matt titanium 710. **Bangkok, ottoman** seat upholstered in woven cowhide color olive 5006, metal feet in matt titanium 710, Design Center design. **Tris, coffee tables** structure veneered in Canaletto walnut with raw-wood effect, top in matt Calacatta Gold marble, Design Center design. **Inca, rug** wool and cotton, Sand color, Juma design.

PIANALE

in legno multistrato rivestito
in cuoio rigenerato nei colori
grigio 5003, testa di moro 5004,
testa di moro scuro 5013, nero 5005, oliva 5006,
rosso bulgaro 5008, sabbia 5001, tabacco 5015.
Telaio in ferro verniciato nero con appoggio
a terra su puntali in materiale termoplastico.

STAFFE SCHIENALI / BRACCIOLI

in metallo nelle finiture
satinato, cromato, cromato nero, brunito,
antracite lucido, titanium opaco 710.
Barre in legno massello di noce canaletto
nelle finiture
effetto grezzo, naturale, tinto extra;
o massello di frassino nelle finiture
naturale, tinto noce, tinto teak, tinto wengé,
tinto marrone, tinto ebano;
o massello di rovere nella finitura
effetto grezzo.

Possibilità di rivestire le barre in cuoio rigenerato
nello stesso colore del pianale.

CUSCINI SEDUTA

in poliuretano espanso a densità differenziata
con strato esterno in piuma d'oca sterilizzata
(certificata Assopiuma, etichetta oro)
rivestiti in tessuto protettivo accoppiato.

CUSCINI SCHIENALE / BRACCIOLO

in poliuretano espanso a densità differenziata
con strato esterno in piuma d'oca sterilizzata
(certificata Assopiuma, etichetta oro) rivestiti
in tessuto protettivo accoppiato.

CUSCINI OPTIONAL

in piuma d'oca sterilizzata
(certificata Assopiuma, etichetta oro),
a richiesta con supplemento di prezzo.

RIVESTIMENTO

sfoderabile sia nella versione in tessuto
che nella versione in pelle.

PROFILO RIVESTIMENTO

la confezione prevede un profilo in gros grain
che può essere realizzato in tutti i colori
della cartella campioni.

PLATFORM

in plywood clad in bonded leather
in the following colors:
grey 5003, dark brown 5004,
extra dark brown 5013, black 5005, olive 5006,
russian red 5008, sand 5001, tabacco 5015.
Frame in iron painted black;
rests on tips made of thermoplastic material.

BACKREST/ARMREST SUPPORTS

in metal in
satin, chrome, black chrome, burnished,
glossy anthracite, matt titanium 710 finish.
Bars in solid Canaletto walnut with
raw-wood effect, natural, stained walnut
extra finish;
or in solid ash with
natural finish or stained walnut, stained teak,
stained wenge, stained brown or stained ebony;
or in solid oak with
raw-wood effect finish.

Option of cladding the bars in bonded leather
in the same color as the platform.

SEAT CUSHIONS

in variable density polyurethane foam
with external layer of sterilized goose-down
(Assopiuma certified, Gold label) padding,
covered with a protective laminated fabric.

BACKREST/ARMREST CUSHIONS

in variable density polyurethane foam
with external layer of sterilized goose-down
(Assopiuma certified, Gold label) padding,
covered with a protective laminated fabric.

OPTIONAL CUSHIONS

in sterilized goose down
(Assopiuma certified, Gold label);
upon request, with upcharge.

UPHOLSTERY

removable in both the fabric and leather versions.

UPHOLSTERY PIPING

tailoring detail includes grosgrain piping
that can be crafted in all the colors
on the sample board.

FIANCO | END UNIT

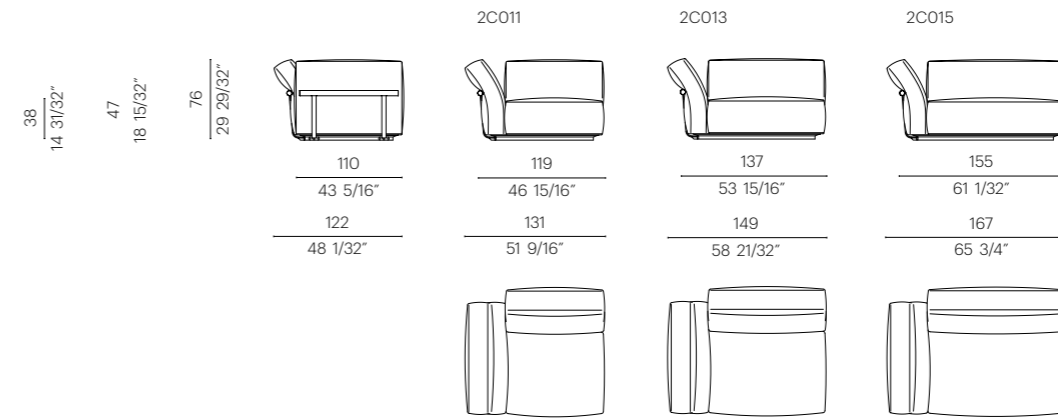

FIANCO | END UNIT

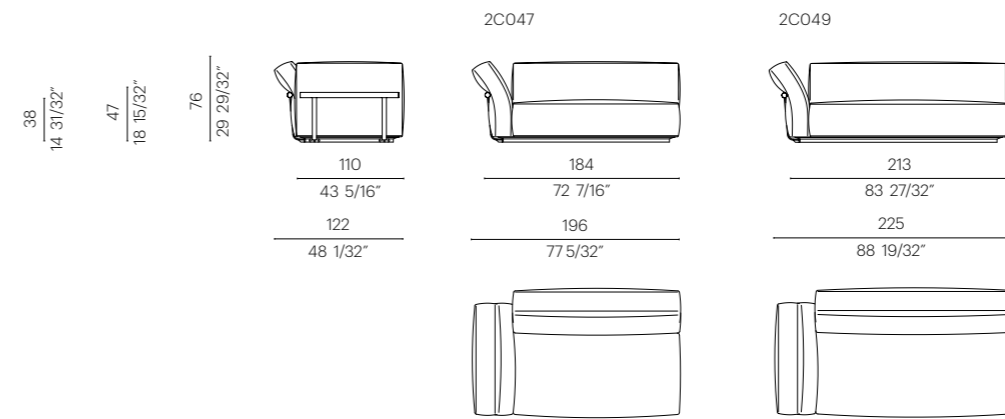

FIANCO | END UNIT

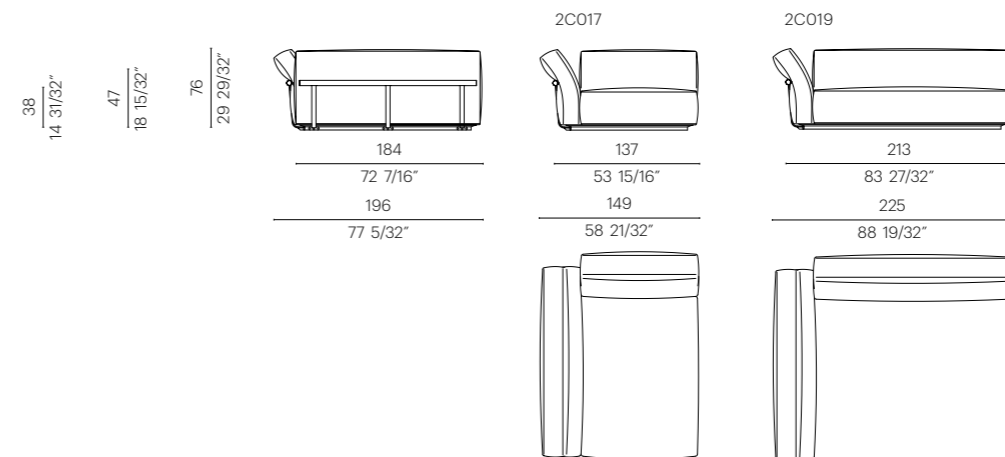

FIANCO - BRACCIOLO BASSO | END UNIT - LOW ARMREST

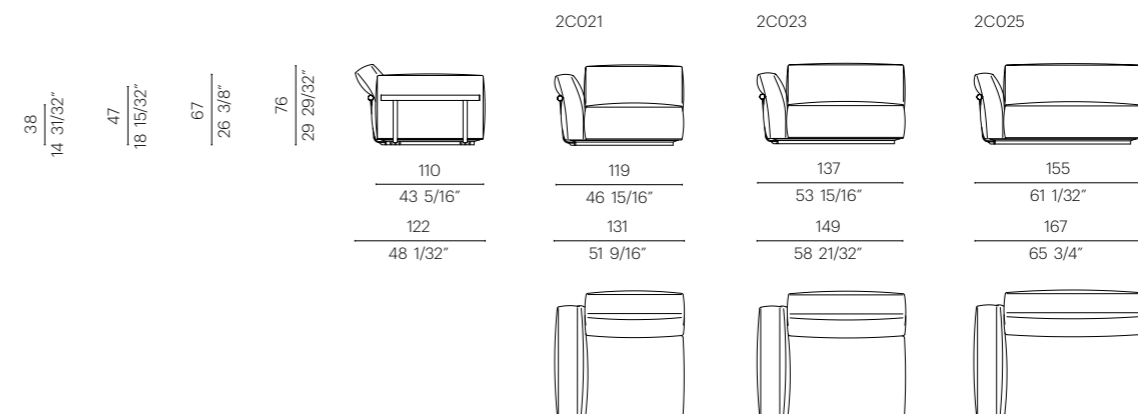

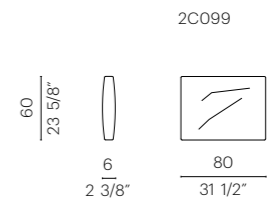
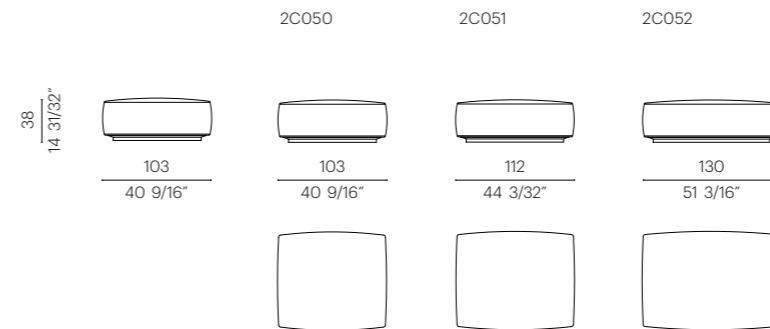
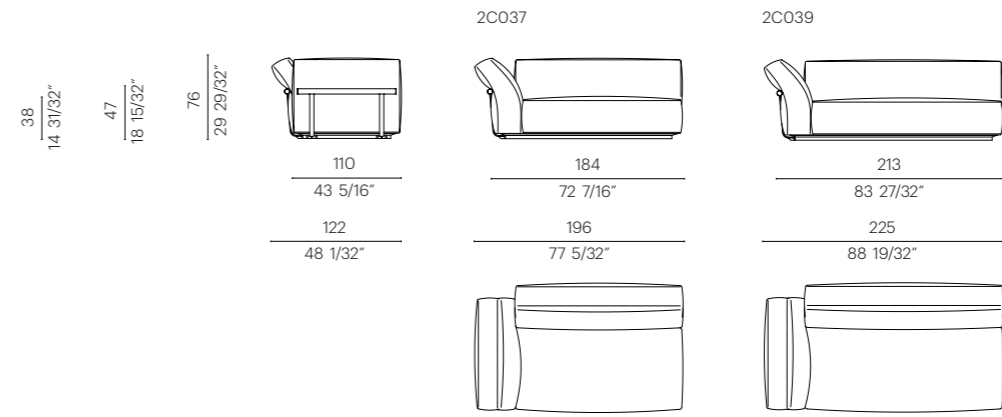
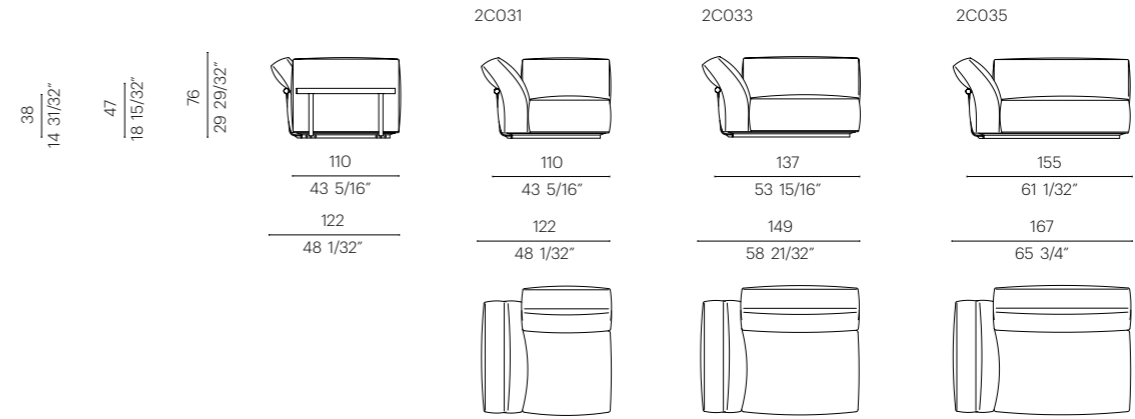
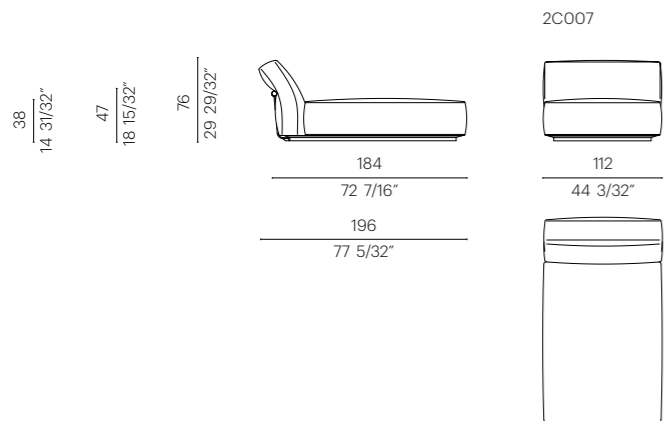
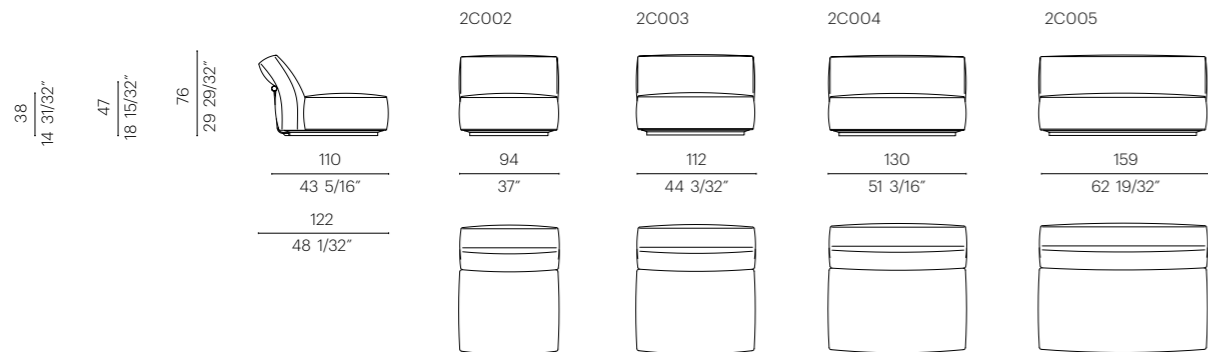
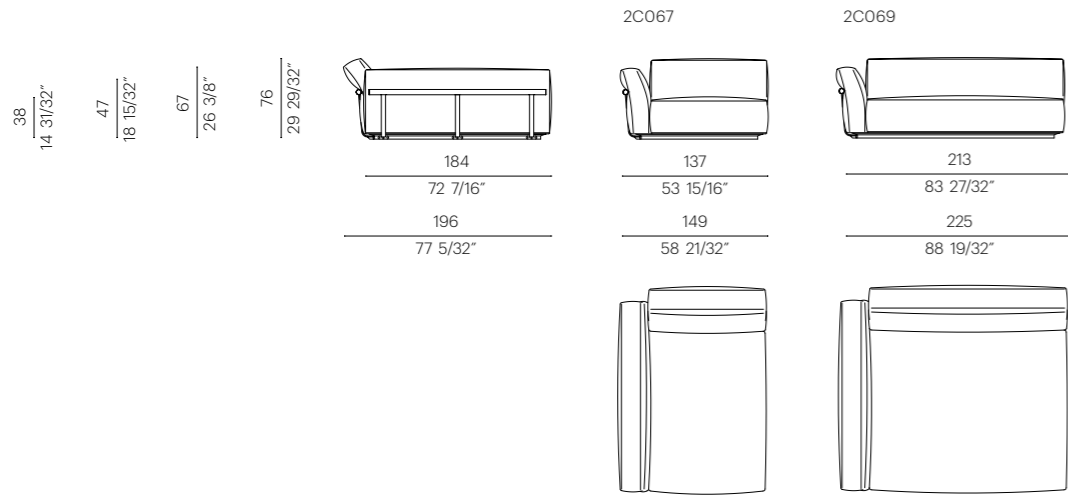
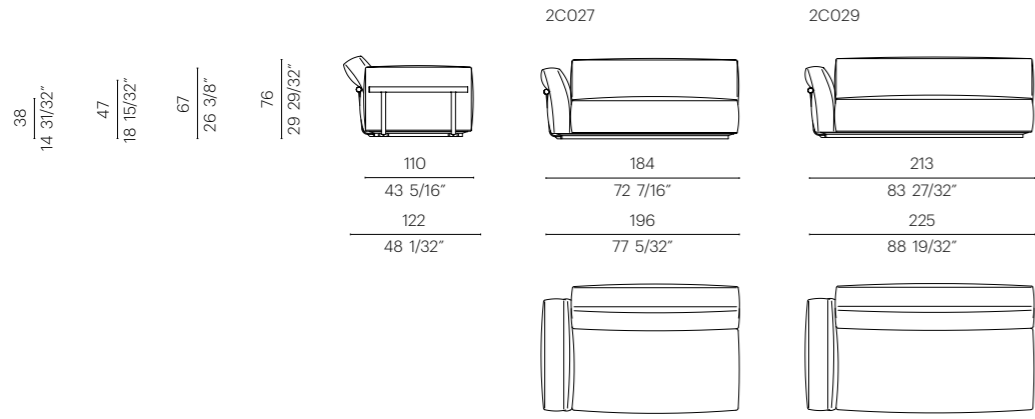

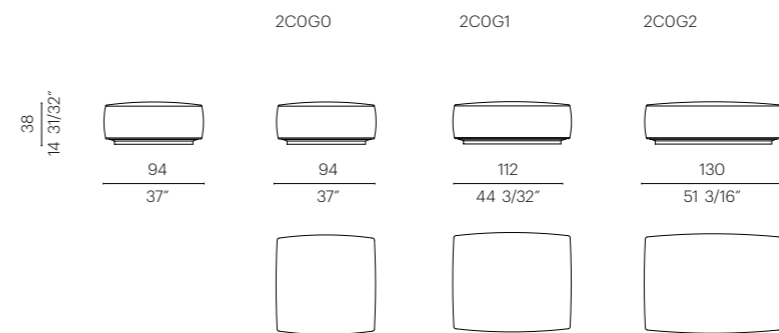
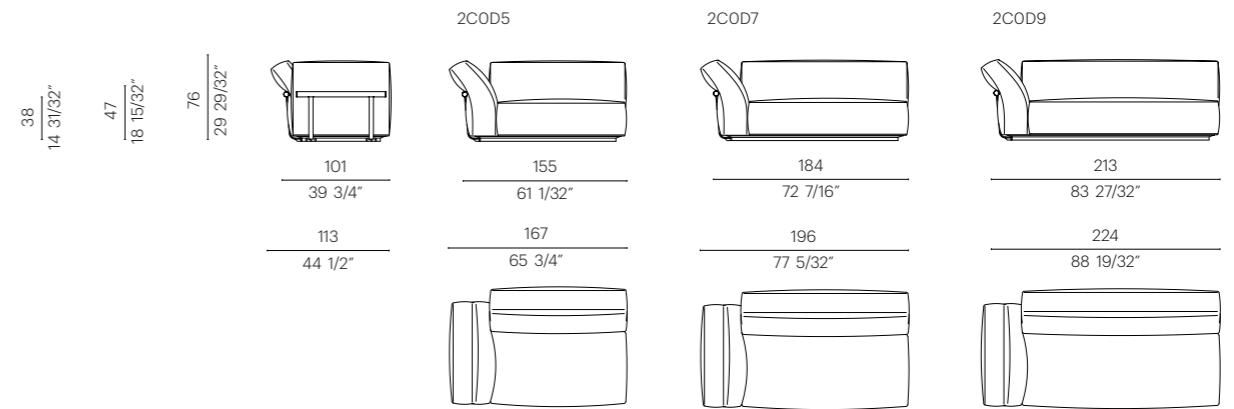
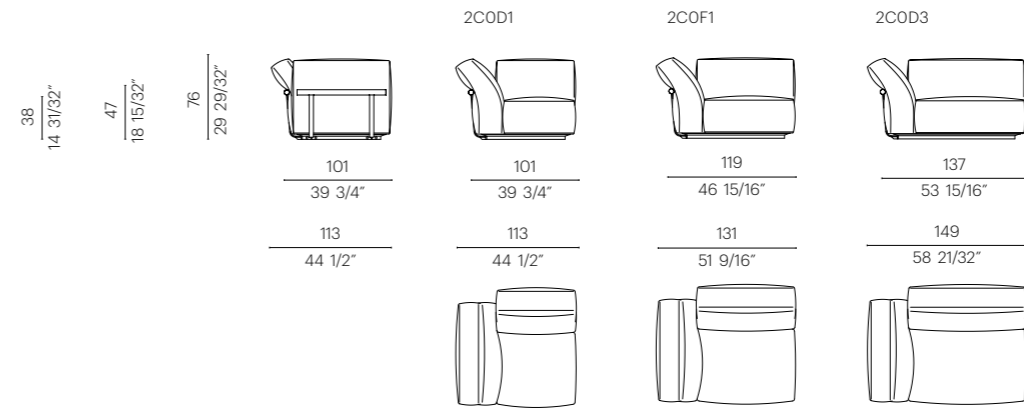
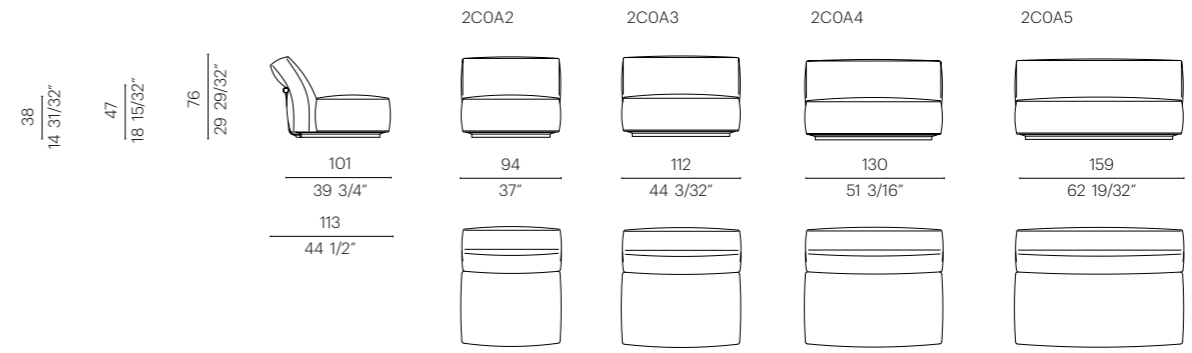
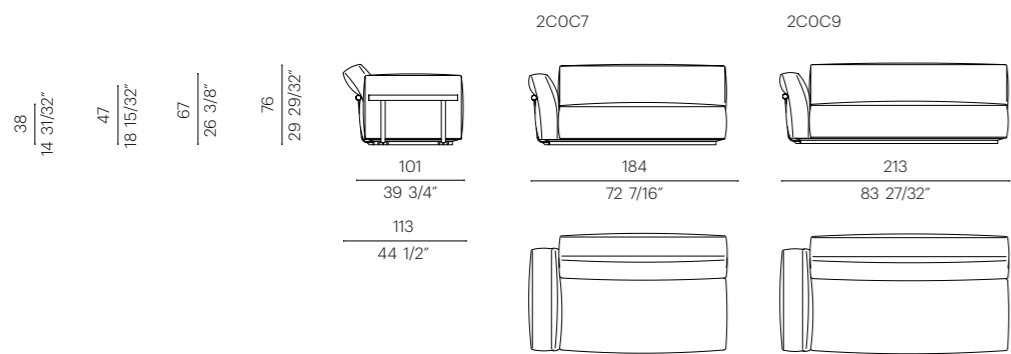
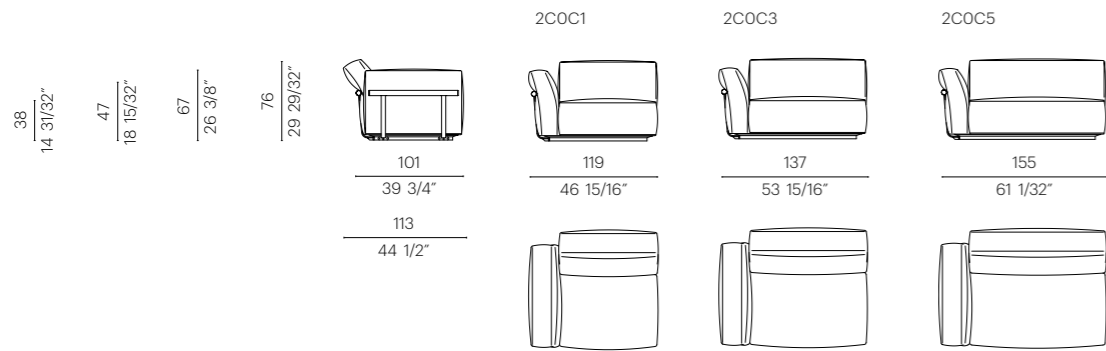
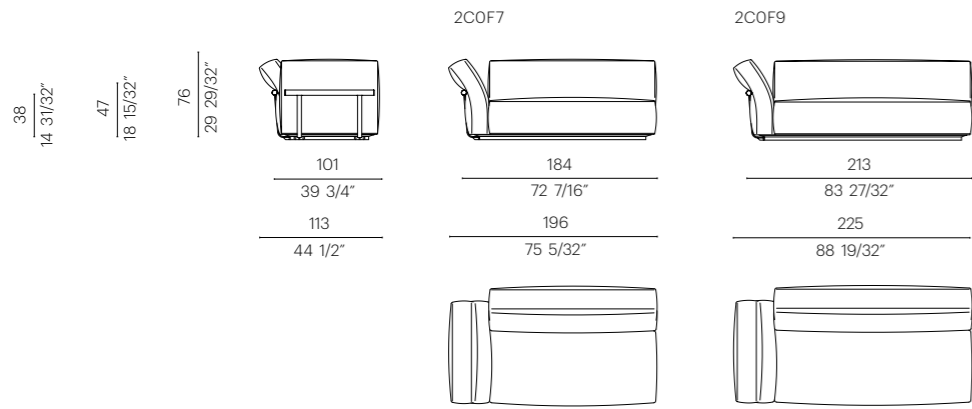
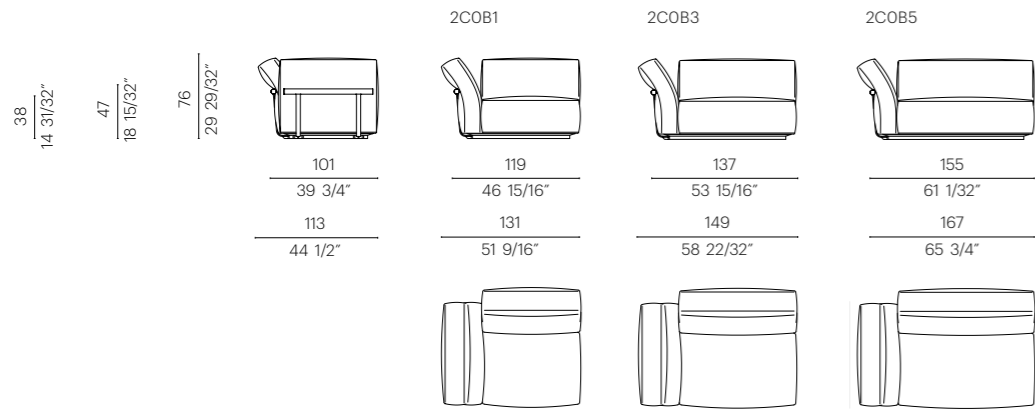

art direction
JUMA

images
SUPREMA UNLIMITED REALITY

styling
GAIA MARCHESINI
GIORDANO SARNO

October 2024
All rights are reserved.
No part of this publication may be reproduced, stored in a retrieval system or transmitted in any form or by any means, electronic, mechanical, photocopying, recording or otherwise, without prior consent of the company.

Flexform S.p.A.
Via Einaudi 23/25, 20821 Meda (MB) Italia | T +39 0362 3991
info@flexform.it www.flexform.it

Flexform reserves the right to make to its models any technological and aesthetical improvement, including modifications of sizes and materials, without prior notice.

