

SOFA SYSTEM

GROUNDPIECE

DESIGN ANTONIO CITTERIO

FLEXFORM

SOFA SYSTEM

GROUNDPIECE

DESIGN ANTONIO CITTERIO

FLEXFORM

“GROUNDPIECE GREW OUT OF THE OBSERVATION OF EVERYDAY LIFE.
A SEATING SYSTEM DESIGNED TO SEAMLESSLY WELCOME DIFFERENT ACTIVITIES
- FROM RELAXATION TO WORK - IN CONTEMPORARY LIVING.”

Antonio Citterio

Quando, nel 2001, Antonio Citterio progettò Groundpiece, non immaginava che quel divano avrebbe segnato un prima e un dopo nella storia dell'arredo imbottito. Nato quasi in controtendenza, con forme basse, profonde, destrutturate e non convenzionali, Groundpiece è diventato negli anni best seller indiscusso di Flexform, innovando l'idea stessa di divano. Il progetto nasce da un'attenta osservazione dei cambiamenti negli stili di vita. La casa, e in particolare il soggiorno, non sono più ambienti statici, ma spazi fluidi in cui si sovrappongono relax, lettura, lavoro e conversazione. Groundpiece ha interpretato questa trasformazione con naturalezza, sviluppando una flessibilità compositiva: le proporzioni si dilatano, l'estetica si alleggerisce, le sedute si abbassano - quasi a sfiorare il pavimento, e una linea continua tra schienale e braccioli permette di accostare liberamente gli elementi, dando forma a soluzioni versatili. Per garantire il massimo comfort, il progetto introduce un rullo agganciato ai cuscini schienale, che amplia la superficie d'appoggio e migliora l'ergonomia e la sensazione di benessere. Un'altra intuizione distintiva è la possibilità di sostituire braccioli e schienali con strutture a giorno in metallo rivestito in cuoio, trasformandoli in utili librerie. Elementi che ampliano ulteriormente le configurazioni possibili senza compromettere l'equilibrio visivo, rispondendo a un modo di progettare la zona giorno come un ambiente aperto e dinamico. Un divano che si compone e ricomponde, capace di adattarsi a scenari differenti con coerenza formale. Un progetto che ha saputo evolversi, rimanendo ancora oggi una delle espressioni più attuali del vivere contemporaneo.

In 2001, when Antonio Citterio designed Groundpiece, he had no idea the sofa would define a before-and-after moment in the history of upholstered furniture. Running almost counter to current trends with low, deep, deconstructed and unconventional shapes, over the years Groundpiece has become Flexform's undisputed best-seller, transforming the very concept of the sofa. The design project grew out of astute observation of changes in lifestyles. No longer a static place, the home and, above all, the living room, become a fluid space in which relaxation, reading, work and conversation overlap. Groundpiece brought a natural interpretation to this transformation, developing the idea of compositional flexibility - expanded proportions, a lighter aesthetic, the seats are lower, almost touching the floor, and one continuous line between the backrest and armrests - allows elements to be freely combined, inspiring versatile solutions. To ensure the utmost in comfort, the design introduces a bolster attached to the backrest cushions that expands the support surface, enhancing ergonomics and a sense of well-being. Another original insight was the idea of replacing the armrests and backrests with open metal structures clad in cowhide, transforming them into practical bookshelves. These elements further expanded the array of possible arrangements without compromising visual balance, responding to a way of designing the living area as an open and dynamic environment. A sofa that can be arranged and rearranged, able to adapt seamlessly to different settings while remaining aesthetically coherent. A design project that has gracefully evolved, and is still today one of the most current expressions of contemporary living.

THE SIMPLICITY OF ITS LOOK HERALDS
NEW RELATIONSHIPS BETWEEN
FURNISHINGS, SPACE AND FUNCTION.

LA VERSIONE LINEARE DI GROUNDPIECE SI AFFERMA COME IL PUNTO DI RIFERIMENTO PER UN DIVANO CAPACE DI RISPONDERE A OGNI ESIGENZA, GRAZIE ALLA SUA MODULARITÀ E VERSATILITÀ. UNENDO COMFORT E UNA COMPOSIZIONE CHE APRE AL DIALOGO TRA GLI SPAZI, LE CONFIGURAZIONI VIS-À-VIS E DORMEUSE SI INTEGRANO CON ELEGANZA IN AMBIENTI E COMPOSIZIONI ARCHITETTONICHE DIFFERENTI.

THANKS TO ITS MODULARITY AND VERSATILITY, THE STAND-ALONE VERSION OF GROUNDPIECE IS FIRMLY ESTABLISHED AS THE BENCHMARK FOR A SOFA CAPABLE OF RESPONDING TO ANY NEED. COMBINING COMFORT AND COMPOSITIONAL FLEXIBILITY THAT STIMULATES DIALOG BETWEEN SPACES, THE FACE-TO-FACE AND DAYBED ARRANGEMENTS INTEGRATE ELEGANTLY INTO DIFFERENT SETTINGS AND ARCHITECTURAL LAYOUTS.











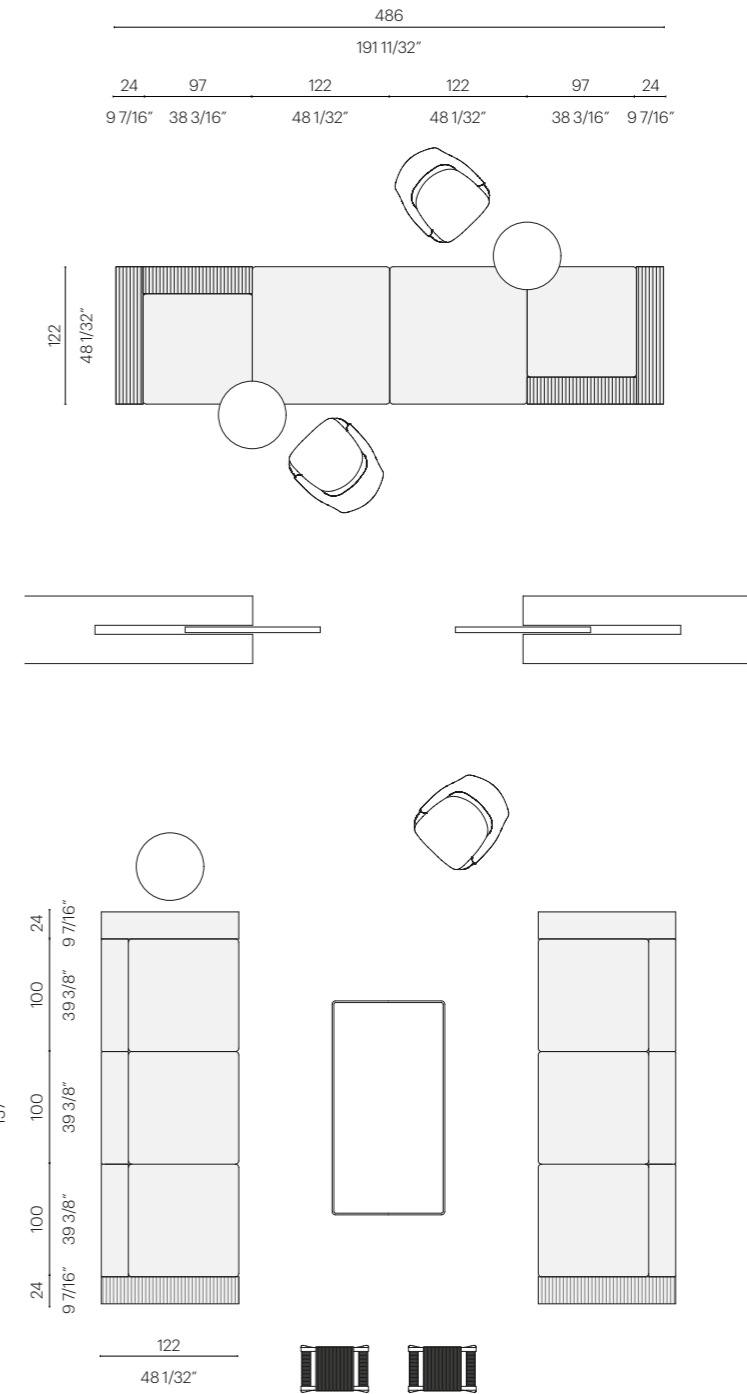

Groundpiece, divani componibili base in metallo, braccioli rivestiti in cuoio color tabacco 5015, braccioli rivestiti in tessuto Essence 62, cuscini di seduta, schienale, cuscini con rullo e optional rivestiti in tessuto Essence 62. **Groundpiece, divano componibile** base in metallo, braccioli e schienale rivestiti in cuoio color tabacco 5015, cuscini di seduta, cuscini con rullo e optional rivestiti in tessuto Egypt 96, cuscini con rullo e optional rivestiti in tessuto Essence 62. **Guscio, poltrone** schienale e cuscino rivestiti in pelle Deluxe 629, piedi in noce canaletto extra. **Fly, tavolini** struttura in metallo cromato, piano in noce canaletto effetto grezzo. **Giano, pouf** struttura in noce canaletto extra, seduta in corda in cuoio color tabacco 5015. **Pico, tavolino** struttura in metallo satinato, piano in marmo Calacatta oro opaco, Design Center design. **Mori, tappeto** lana e cotone, colore Milk, Juma design.

Groundpiece, sectional sofas metal base, armrests clad in cowhide color tabacco 5015, armrests upholstered in Essence 62 fabric, seat, backrest, bolster and optional cushions upholstered in Essence 62 fabric. **Groundpiece, sectional sofa** metal base, armrests and backrest upholstered in cowhide color tabacco 5015, seat, bolster and optional cushions upholstered in Egypt 96 fabric, bolsters and optional cushions upholstered in Essence 62 fabric. **Guscio, armchairs**, backrest and cushion upholstered in Deluxe 629 leather, legs in Canaletto walnut extra. **Fly, side tables** metal structure with chrome finish, top in Canaletto walnut with raw-wood effect. **Giano, ottomans** structure in Canaletto walnut extra, seat in cowhide cord color tabacco 5015. **Pico, coffee table** metal structure with satin finish, top in matt Calacatta Gold marble, Design Center design. **Mori, rug** wool and cotton, color Milk, Juma design.

THE ARCHITECTURE OF COMFORT:
AN OPEN SYSTEM THAT DEFINES
DOMESTIC SPACE.

GROUNDPIECE IN VERSIONE ANGOLARE STRUTTURA LO SPAZIO ATTRAVERSO VOLUMI GENEROSI E LINEE PURE. IL DIVANO SI APRE ALLA POSSIBILITÀ DI ESSERE ABITATO SECONDO USI MOLTEPLICI. LA FLESSIBILITÀ COMPOSITIVA, LA VARIETÀ DELLE FINITURE E L'INTERAZIONE CON ALTRI ELEMENTI FLEXFORM LO RENDONO UN PROGETTO DINAMICO, DOVE ESTETICA E FUNZIONALITÀ SI INCONTRANO IN MODO EVOLUTO.

AN L-SHAPED ARRANGEMENT OF GROUNDPIECE LENDS STRUCTURE TO THE SPACE THROUGH GENEROUS SHAPES AND PURE LINES. THE SOFA OPENS ITSELF TO THE POSSIBILITY OF BEING EXPERIENCED IN MULTIPLE WAYS. COMPOSITIONAL FREEDOM, A VARIETY OF FINISHES, AND THE ABILITY TO INTERACT WITH OTHER FLEXFORM ELEMENTS MAKE THIS A DYNAMIC DESIGN, WHERE AESTHETICS AND FUNCTIONALITY CONVERGE IN A CONCEPT THAT REDEFINES CONVENTION.







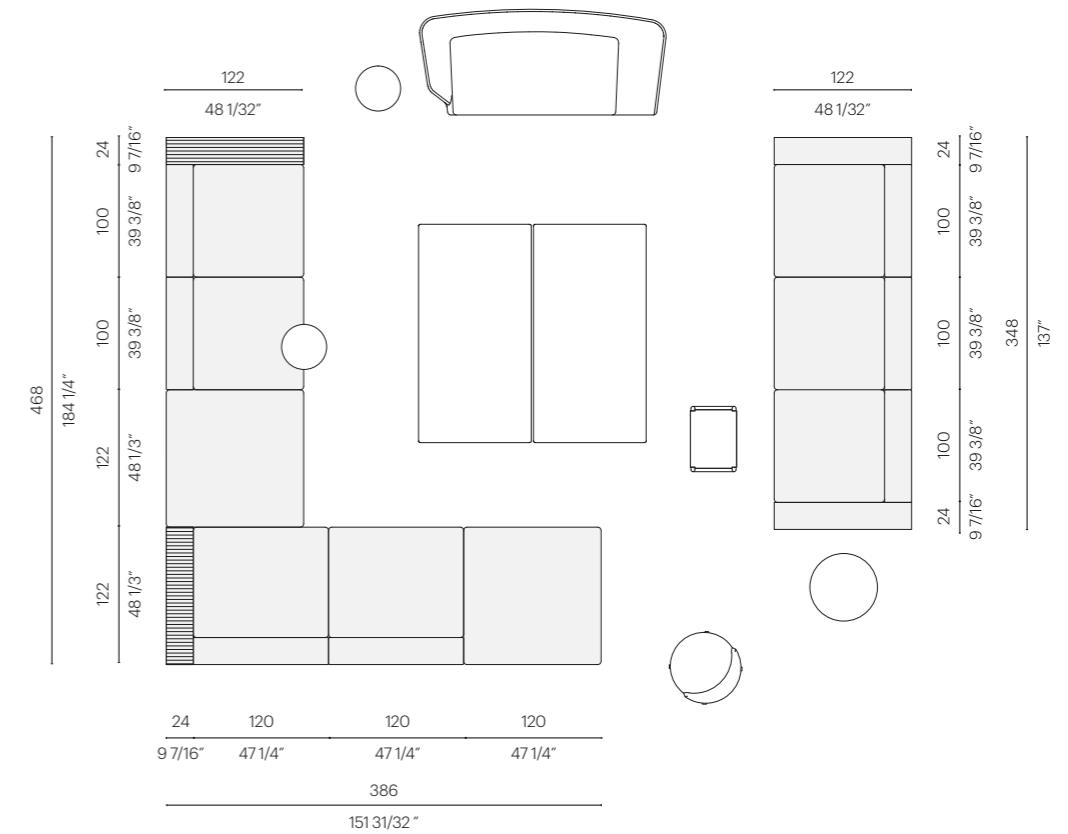

Groundpiece, divano componibile base in metallo, braccioli rivestiti in cuoio color testa di moro 5004, cuscini di seduta, schienale, cuscini con rullo e optional rivestiti in tessuto Medina 90. **Groundpiece, divano componibile** base in metallo, braccioli rivestiti in tessuto Medina 90, cuscini di seduta, schienale, cuscini con rullo e optional rivestiti in tessuto Medina 90. **Zeus, chaise longue** struttura rivestita in tessuto Manila 758, cuscini di seduta, schienale e optional rivestiti in tessuto Manila 758, piedi in titanium opaco 710. **Brig, pouf** struttura in massello di frassino tinto marrone, seduta in cuoio color testa di moro 5004. **Feel Good, poltrona** schienale e cuscino rivestiti in tessuto Tracy 1766, piedi in metallo cromato. **Fly, tavolini** struttura in metallo titanium opaco 710, piano in massello di frassino tinto marrone. **Pico, tavolini** struttura in metallo titanium opaco 710, piano in marmo marron Damasco opaco, Design Center design. **Mori, tappeto** lana e cotone, colore Milk, Juma design.

Groundpiece, sectional sofa metal base, armrests upholstered in cowhide color dark brown 5004, seat, backrest, bolster and optional cushions upholstered in Medina 90 fabric. **Groundpiece, sectional sofa** metal base, armrests upholstered in Medina 90 fabric, seat, backrest, bolster and optional cushions upholstered in Medina 90 fabric. **Zeus, chaise longue** structure upholstered in Manila 758 fabric, seat, backrest and optional cushions upholstered in Manila 758 fabric, feet in matt titanium 710. **Brig, ottoman** structure in solid ash stained brown, seat in cowhide color dark brown 5004. **Feel Good, armchair** backrest and cushion upholstered in Tracy 1766 fabric, metal feet with chrome finish. **Fly, side tables** metal structure in matt titanium 710, top in solid ash stained brown. **Pico, coffee tables** metal structure in matt titanium 710, top in matt Marron Damasco marble, Design Center design. **Mori, rug** wool and cotton, color Milk, Juma design.

AN INVITATION TO INHABIT
UNINTERRUPTED SPACES, BETWEEN
FUNCTION, BEAUTY AND POSSIBILITY.

GROUNDPIECE, NELLA CONFIGURAZIONE A PENISOLA, SI SVILUPPA COME UNA PIATTAFORMA PENSATA PER ACCOGLIERE, OSPITARE, VIVERE. INTEGRANDO FINITURE RICERCATE, IL DIVANO DIALOGA NATURALMENTE CON GLI ALTRI ARREDI FLEXFORM, CONTRIBUENDO A UN'IDEA DI LIVING SENZA GERARCHIE, DOVE OGNI ELEMENTO PARTECIPA ALLA COSTRUZIONE DI UNO SPAZIO COERENTE E SOFISTICATO.

IN ITS PENINSULA CONFIGURATION, GROUNDPIECE UNFOLDS LIKE A PLATFORM ENVISIONED TO WELCOME, ACCOMMODATE AND BE ENJOYED. BY INCORPORATING ELEGANT FINISHES, THE SOFA SPONTANEOUSLY INTERACTS WITH THE OTHER FLEXFORM FURNISHINGS AND CONTRIBUTES TO AN IDEA OF LIVING WITHOUT HIERARCHIES, WHERE EACH ELEMENT PARTICIPATES IN CREATING A COHERENT AND SOPHISTICATED SPACE.





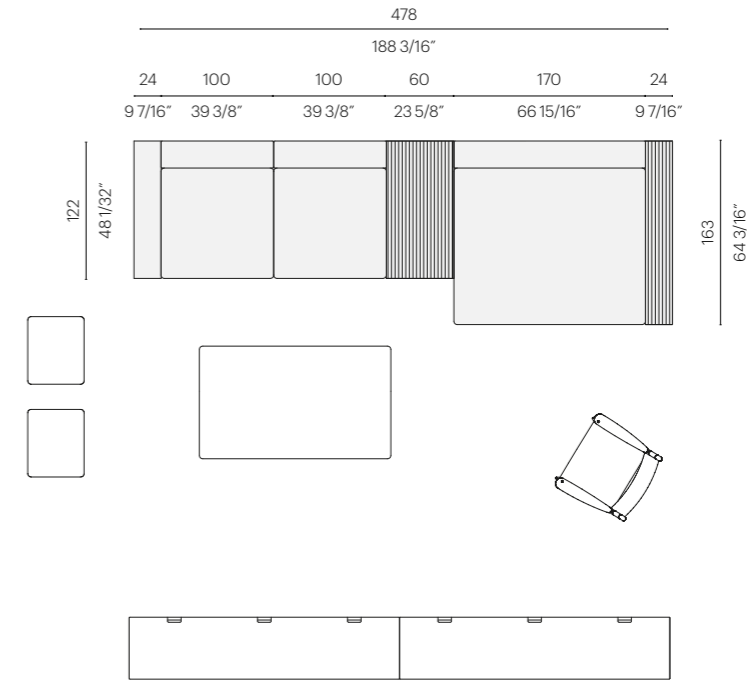

Groundpiece, divano componibile base in metallo, bracciolo rivestiti in cuoio color oliva 5006, bracciolo rivestito in tessuto Emblema 874, cuscini di seduta, schienale e cuscini con rullo rivestiti in tessuto Emblema 874, tavolino rivestito in cuoio color oliva 5006. **Giano, tavolino** struttura rovere effetto grezzo, piano in marmo Emperador opaco. **Bangkok, pouf** seduta rivestita in cuoio intrecciato color oliva 5006, piedi in metallo cromato, Design Center design. **Piuma, contenitore** struttura impiallacciata in rovere effetto grezzo, piedi in metallo titanium opaco 710. **Tessa, poltrona** struttura in rovere effetto grezzo, piedi in metallo brunito, intreccio in paglia di fiume. **Inca, tappeto** lana e cotone, colore Stone, Juma design.

Groundpiece, sectional sofa metal base, armrest clad in cowhide color olive 5006, armrest upholstered in Emblema 874 fabric, seat, backrest and bolster cushions upholstered in Emblema 874 fabric, side table clad in cowhide color olive 5006. **Giano, coffee table** oak structure with raw-wood effect, top in matt Emperador marble. **Bangkok, ottomans** seat upholstered in woven cowhide color olive 5006, metal feet with chrome finish, Design Center design. **Piuma, cabinet** structure in oak veneer with raw-wood effect, metal feet in matt titanium 710. **Tessa, armchair** structure in oak with raw-wood effect, burnished metal feet, woven paper. **Inca, rug** wool and cotton, color Stone, Juma design.

STRUTTURA

elementi in metallo con imbottitura in poliuretano stampato rivestita in tessuto protettivo accoppiato

STRUTTURA POUF

in legno massello con imbottitura in poliuretano espanso rivestita in tessuto protettivo accoppiato

CUSCINI SEDUTA

in piuma d'oca sterilizzata (certificata Assopiuma, etichetta oro) con inserto in materiale indeformabile o in poliuretano espanso e dacron. Seduta premium in piuma d'oca sterilizzata (certificata Assopiuma, etichetta oro) con inserto in materiale indeformabile ad alta resilienza

CUSCINI SCHIENALE

in piuma d'oca sterilizzata (certificata Assopiuma, etichetta oro) con o senza rullo reggiscuscino in poliuretano espanso. I cuscini schienale sono a richiesta con supplemento di prezzo

BRACCIOLO "TESSUTO 24"

in metallo con imbottitura in poliuretano stampato rivestito in tessuto protettivo accoppiato

BRACCIOLO "TESSUTO 12"

in legno massello con imbottitura in poliuretano espanso rivestito in tessuto protettivo accoppiato

BRACCIOLO CUIOIO

in metallo rivestito in cuoio nei colori: grigio 5003, testa di moro 5004, testa di moro scuro 5013, nero 5005, oliva 5006, rosso bulgaro 5008, sabbia 5001, tabacco 5015, scamosciato moro 6004, scamosciato nero 6005, scamosciato oliva 6003, scamosciato sabbia 6001

PIEDI

in metallo verniciato a forno con polveri epossidiche. Appoggio a terra su puntali in materiale termoplastico

RIVESTIMENTO

sfoderabile sia nella versione in tessuto che nella versione in pelle

STRUCTURE

Structure elements in metal with molded polyurethane padding, covered with a protective laminated fabric

STRUCTURE OTTOMAN

in solid wood with polyurethane foam padding, covered with a protective laminated fabric

SEAT CUSHIONS

in sterilized goose down (Assopiuma certified, gold label) with insert in crushproof material; or in polyurethane foam and dacron. Premium seat cushions in sterilized goose down (Assopiuma certified, gold label) with insert in high resilience crushproof material

BACKREST CUSHIONS

in sterilized goose down (Assopiuma certified, gold label) with or without polyurethane foam support bolster. Optional backrest cushions are upon request, with upcharge

'FABRIC 24' ARMREST

in metal with molded polyurethane padding, covered with a protective laminated fabric

'FABRIC 12' ARMREST

in solid wood with polyurethane foam padding, covered with a protective laminated fabric

COWHIDE ARMREST

in metal upholstered in cowhide in the following colors: russian red 5008, olive 5006, black 5005, dark brown 5004, dark brown extra 5013, grey 5003, sand 5001, tabacco 5015. Also available in black suede 6005, dark brown suede 6004, olive suede 6003, sand suede 6001

FEET

in epoxy powder-coated metal. Rests on pads made of thermoplastic material

UPHOLSTERY

is removable in both the fabric and leather versions

ELEMENTO | UNIT

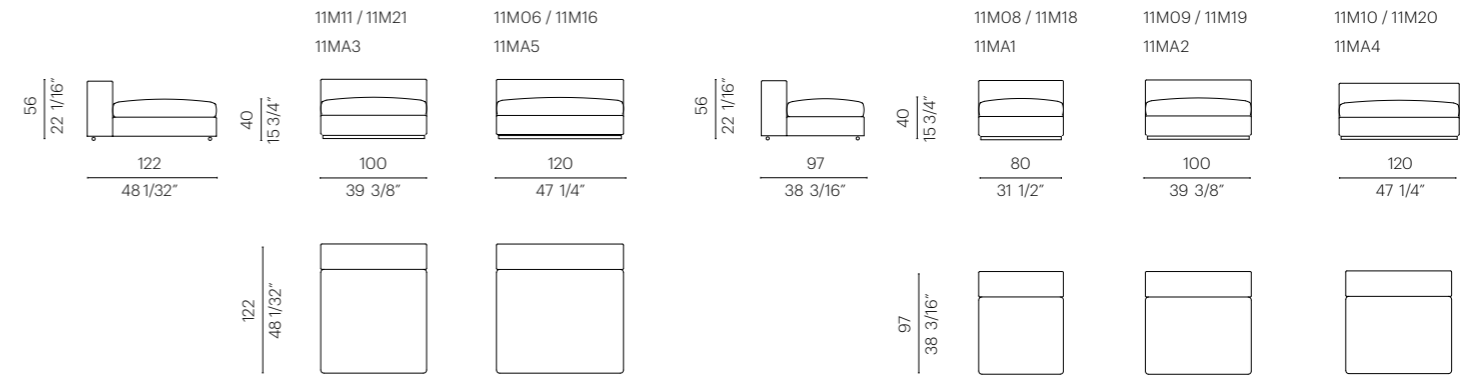

ELEMENTO | UNIT

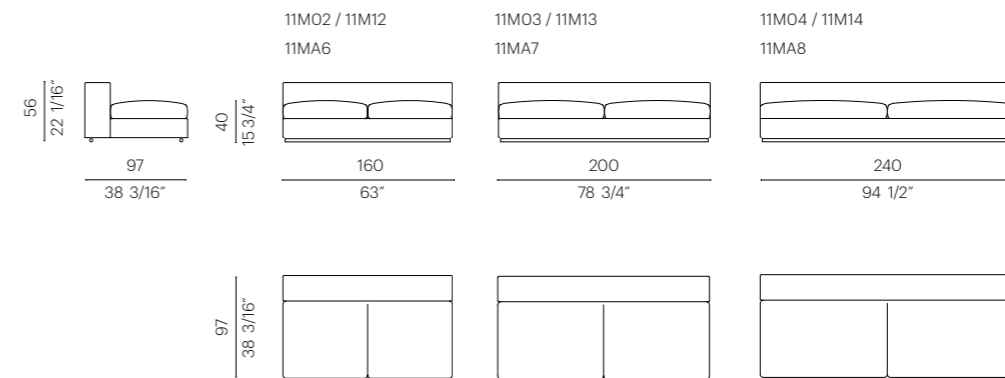

ELEMENTO | UNIT

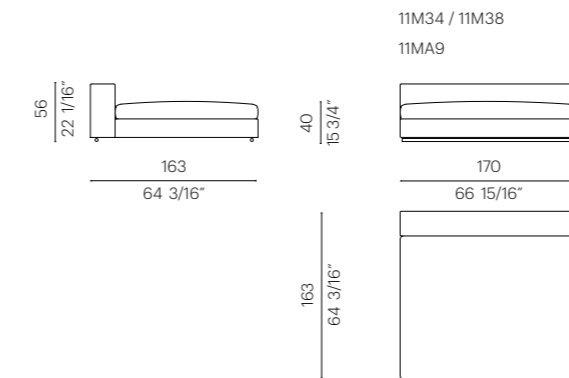

BRACCIOLO | ARMREST

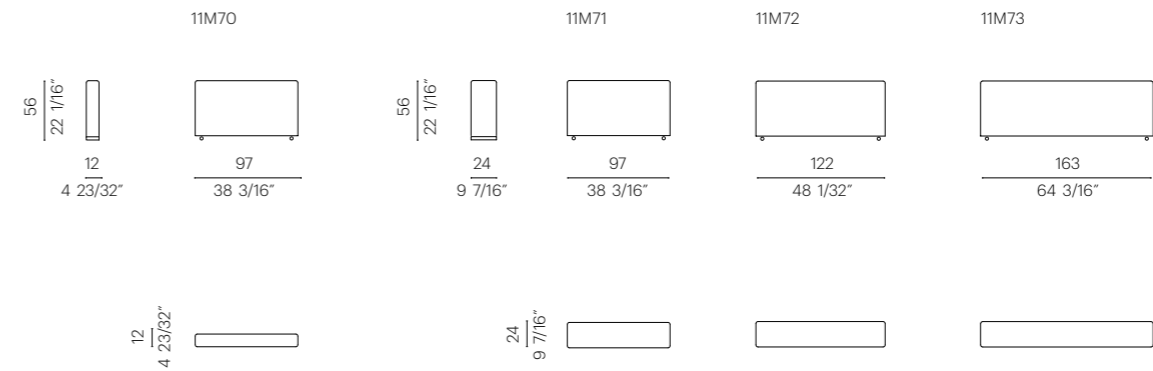

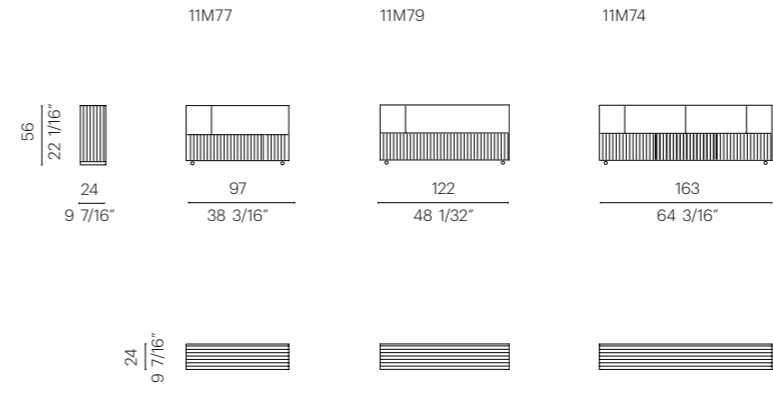
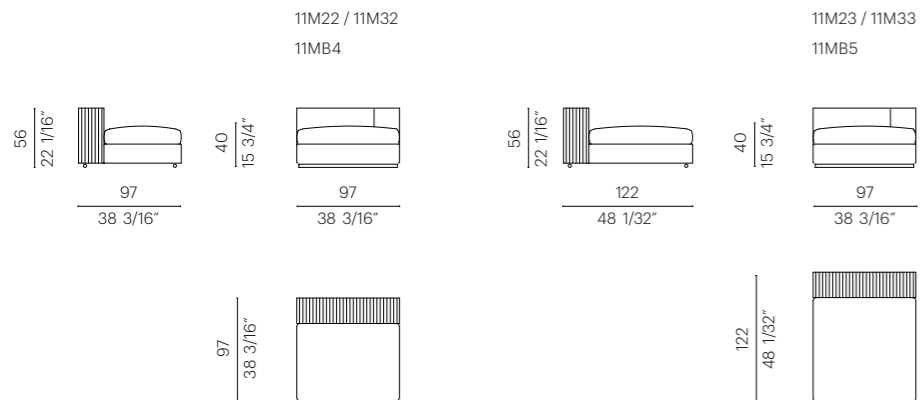
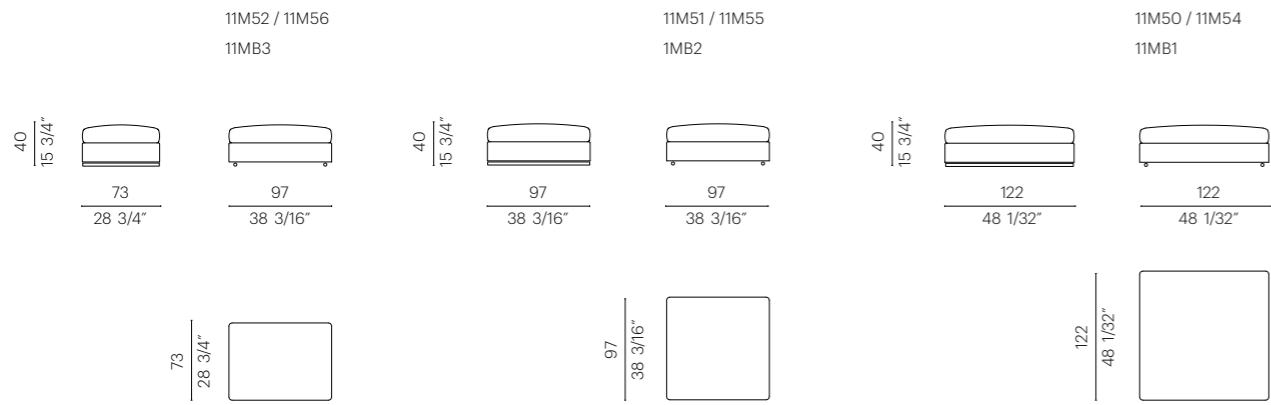
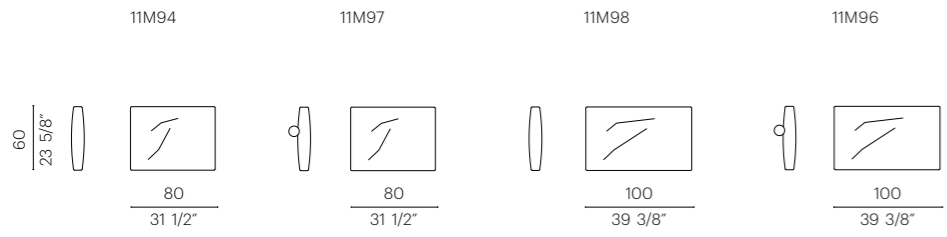
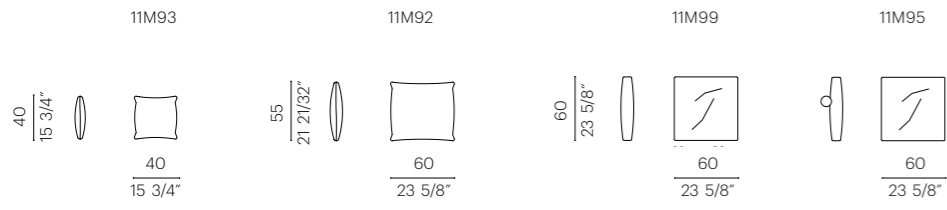

art direction
JUMA

images
SUPREMA UNLIMITED REALITY

styling
GAIA MARCHESINI
GIORDANO SARNO

words
ROBERTA LISSIDINI

May 2025
All rights are reserved.
No part of this publication may be reproduced, stored in a retrieval system or transmitted in any form or by any means, electronic, mechanical, photocopying, recording or otherwise, without prior consent of the company.

Flexform S.p.A.
Via Einaudi 23/25, 20821 Meda (MB) Italia | T +39 0362 3991
info@flexform.it www.flexform.it

Flexform reserves the right to make to its models any technological and aesthetical improvement, including modifications of sizes and materials, without prior notice.

