

MAGIS

Pied-à-terre by BrogliatoTraverso



Brogliato Traverso



Profile:

After graduating in Architecture from Venice University, Italy and various experiences – from learning how to blow glass in Murano to working traditional ceramics in Japan – Alberto Brogliato and Federico Traverso founded BrogliatoTraverso design studio in 2014. Their approach to design is called 'NO TIME, NO SPACE' and refers to their will to make objects with a timeless design that fits any context.

BrogliatoTraverso work by subtracting, creating a detailed sign, but almost invisible. With these finely hinted forms,

their creations establish deep intimate empathy with the users and their surroundings, respecting both of them. Their fine simplification process delivers projects addressing the needs of consumers and made for various companies, including Magis, Cappellini, Guzzini, Infiniti, Il Fanale/Torremato and more.

These partnerships have won the studio many international awards, including ADI Index, the Red Dot Design Award, German Design Award, iF Design Award and Good Design Award.



Design and

Geometric, sculptural, minimal. But above all, extendable.

Pied-à-Terre, the new round table designed by BrogliatoTraverso, is the epitome of convivial style, available in a fixed version (with a diameter of 120 cm) and an extending version (with a diameter of 125 cm that extends to 175 cm). Compact when closed, it opens up with style and ease to make room for guests.

"In its own way, the round table represents a microcosm with different rules for use" said designers Alberto Brogliato and Federico Traverso. "The continuous geometry of the circle means it has no specific orientation, and therefore has the ability to naturally seat guests in a more convivial way compared to rectangular and square tables".

Pied-à-terre stands in stark contrast to other round tables, transforming the ultimate geometric shape into a captivating object that immediately catches the eye in any living space, offering a fresh perspective on what a round table can be.

We asked the designers to reinvent the extending table and the focus was entirely on the circle, the most welcoming and inclusive shape, but with Magis's design approach, unique and never ordinary. And voilà: Pied-à-terre offers domestic architecture in perfect harmony between lightness and stability.

The secret? A static ballast in recycled marble, a strong and distinctive element, that transforms the base into a graphic and sculptural form. A detail as simple as it is iconic, that blends classic architectural inspiration with a more contemporary design approach.

The round design invites conviviality, while the extending mechanism is seamlessly integrated within the form, maintaining its visual clarity. The frame is in steel and the top is in Fenix laminate, in a range of colours. Everything is designed to highlight the action, without hiding it. Because for us, aesthetics and function are one and the same.

Pied-à-Terre is a table that effortlessly furnishes both domestic spaces and contract settings, with distinctive style: Magis style.



Engineering



“In its own way,
the round table
represents a



microcosm
with different
rules for use.”



Information



Product

Materials: frame in painted steel. Base in recycled marbe (black Portoro). Top and leaves in Fenix laminate.

TABLES

Ø120



Frame / white steel
Top / white Fenix laminate
Base / black Portoro

Ø120



Frame / brick red steel
Top / brick red laminate
Base / black Portoro

Ø120



Frame / black steel
Top / black Fenix laminate
Base / black Portoro

Ø125 (extending to 175)



Frame / white steel
Top and leaves / white Fenix laminate
Base / black Portoro

Ø125 (extending to 175)



Frame / brick red steel
Top and leaves / brick red Fenix laminate
Base / black Portoro

Ø125 (extending to 175)



Frame / black steel
Top and leaves / black Fenix laminate
Base / black Portoro

Materials /

frame in steel /



white brick red black

Top and leaves in Fenix laminate /



white black brick red

Base in recycled marble /

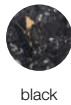

black Portoro

Ø120

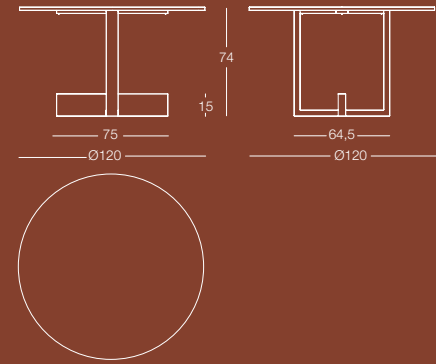

Ø125 (extending to 175)

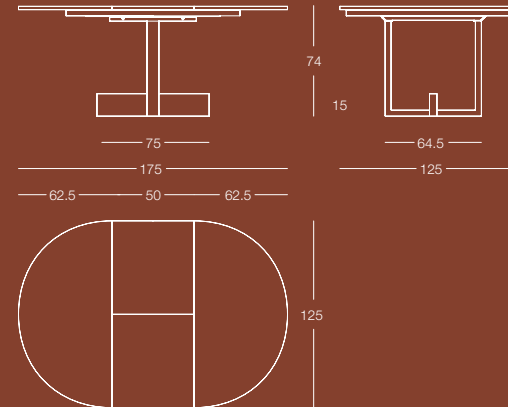

PRODUCT CARE

For cleaning the structure in steel, we recommend using a soft rag, either dry or wet. When needed, use ph-balanced soap diluted in water. Do not use abrasive sponges as they may leave scratches. Avoid using acidic products, solvents and products containing ammonia. We recommend cleaning the tops in Fenix laminate as soon as possible, as giving dirt time to dry can noticeably increase the risk of rings, stains, and surface damages. We recommend paying particular attention to intensely coloured substances (such as coffee, cola, tomato juice, wine, vinegar...). For the base in marble, please avoid using acid products. In case of contact of any acid substance with the marble surface, please remove it immediately. We recommend using water and Marseilles soap for marble cleaning. To remove greasy substances and various stains it is possible to use ammoniacs, denatured alcohol, bicarbonate and hydrogen peroxide. Any marks, signs or irregularities that may be visible on the marble are peculiarities of the materials and should not be considered as faults. Periodic and correct maintenance allows the product to keep its original aspect and lengthens the duration of its performance.

WARNING

Do not use different cleaning products from the ones mentioned above. Do not use the product in an improper way. Once disused, please make sure this product is disposed in an environment-friendly way.



